

Minuteman[®]
Parker[®]

Model:
PR0165-T, K, F

Power Rake

OPERATION

SERVICE

PARTS

CARE

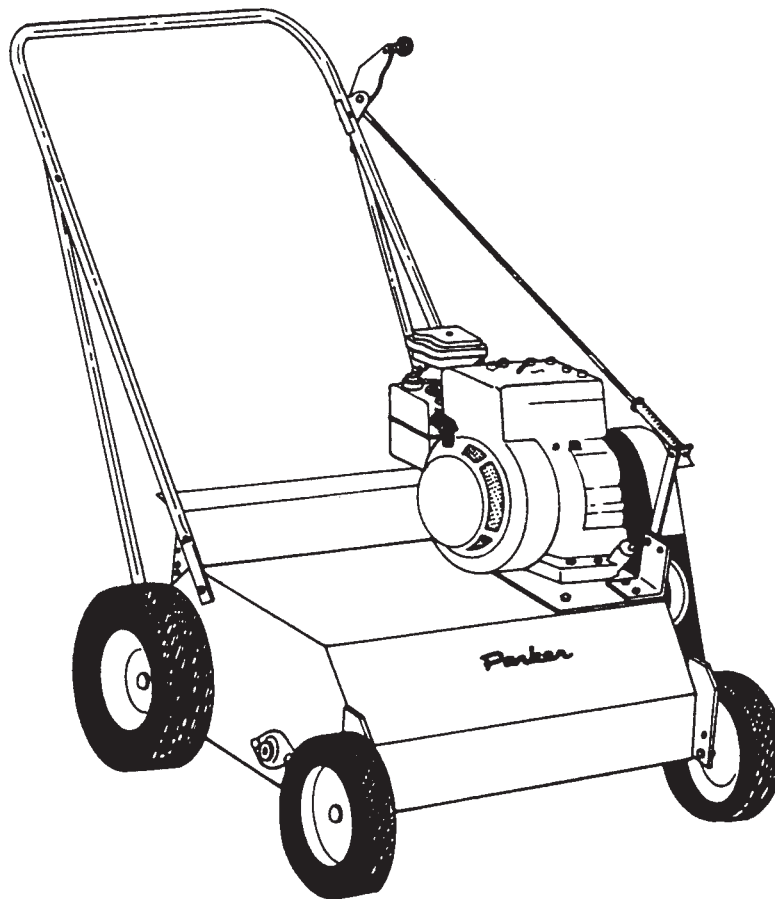



DECLARATION OF CONFORMITY

MANUFACTURER'S NAME: Minuteman International Inc.

MANUFACTURER'S ADDRESS: 111 South Rohlwing Road
Addison, IL. 60101

EQUIPMENT DESCRIPTION: THATCH O MATIC

EQUIPMENT MODEL DESIGNATION: PR8919KH

Application of Council Directives: 89/392/EC, 2000/14/EC, 91/368/EC, 98/37/EC

Harmonized EN standards complied with: EN 292

Additional Standards: ISO 3744, ISO 11094

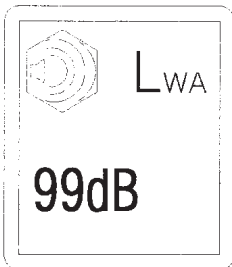

I, the undersigned, hereby declare that the equipment specified above conforms to the above Directive(s) and Standard(s).

SIGNATURE:

Jeffrey Pollack

DATE: *May 3, 2004*

PRINTED NAME:

Jeffrey Pollack

TITLE:

Standards Engineer

TABLE OF CONTENTS

General Safety Instructions	1 & 2
Warning Decal Placement	3
Assembly Instructions	4 & 5
Operation/Maintenance	6
Handle Wheel Assembly	7
Engine Drive Assembly	8 & 9
Tine Reel Assembly	10
Knife Reel Assembly	11
Flail Reel Assembly	12
Warranty	Back Cover

IMPORTANT SAFETY INSTRUCTIONS

READ ALL INSTRUCTIONS BEFORE USING

WARNING

- To prevent personal injury or property damage, do not attempt to start engine until all assembly steps are complete and you have read and understand the safety and operating instructions in this manual.
- Under California law, and under laws of several other states, you are not permitted to operation internal combustion's engine using hydrocarbon fuels on any forest covered, brush covered, or grass covered land, or on land with grain, hay, or other flammable agricultural crop, without an engine spark arrester in continuous effective working order. The engine on your power equipment, like most outdoor power equipment, is an internal combustion engine that burns gasoline, a hydrocarbon fuel. Therefore, your power equipment must be quipped with a spark arrester muffler in continuous effective working order. The spark arrester must be attached to the engine exhaust system in such a manner that flames or heat from the system will not ignite flammable material. Failure of the owner/operator of the equipment to comply with this regulation is a misdemeanor under California law, and may also be a violation of other state and/or federal regulations, laws, ordinances, or codes. Contact your local fire marshal or forest service for specific information about what regulations apply in your area.
- Wear approved safety glasses when operating this equipment. The operation of any powered machine can result in foreign objects being thrown by high-speed rotating parts.
- Wear work gloves, sturdy footwear, and hearing protection when operating this equipment.
- Remove hearing protection and watch for traffic when operating near, or when crossing roadways.
- Before inspecting or servicing any part of equipment, shut off engine, disconnect spark plug wire from spark plug, and make sure that all moving parts have come to a complete stop. Be aware that rotating blades slow down gradually after engine is shut off.
- Exercise extreme caution on slopes and avoid excessively steep slopes.
- Never leave equipment unattended when engine is running. Shut off engine and disconnect spark plug wire from spark plug before leaving equipment. Turn off fuel shut-off if equipped.
- Do not operate this equipment on paved, gravel, or hard surface.
- Do not use Power Rake in areas that have been recently treated with fertilizers, pesticides, or herbicides. Follow chemical manufacturer's safety instructions regarding contact with treated areas.
- Before inspecting or serviceing any part of equipment, shut off engine, disconnect spark plug wire from spark plug, and make sure that all moving parts have come to a complete stop. Be aware that rotating blades slow down gradually after engine is shut off.
- Replace any faulty silencers (muffler or deflector) when necessary.
- If equipment jams or becomes clogged, immediatly shut off engine, disconnect spark plug, and allow all moving parts to come to a complete stop. Use only a wooden stick to clear away debris.
- Never allow children or untrained adults to operate this equipment.
- Keep the area of operation clear of all persons, particularly small children, and pets. Keep bystanders at least 25 feet away from the area of operation.

- Do not run engine in an enclosed area. Engine exhaust contains carbon monoxide gas, a deadly poison that is odorless, colorless, and tasteless.
- Do not operate this equipment near buildings, windows, or air conditioners.
- Do not allow hands or any other part of the body or clothing inside lower housing.
- Do not start engine or operate this equipment with any safety guards or housing removed.

DANGER

Gasoline is highly flammable and its vapors are explosive. To prevent personal injury or property damage:

- Do not add fuel if engine is running or still hot from recent operation. Allow engine to cool for at least three minutes.
- Do not fill fuel tank indoors. After filling, wipe up any spills and move away from gasoline fumes before starting engine.
- Do not allow open flame, matches, or smoking in area.
- Fill fuel tank with fresh, clean unleaded regular automotive gasoline, (leaded regular and unleaded or leaded premium grades of gasoline are acceptable substitutes).
- Do not mix oil with gasoline.
- Clean the area around the fuel fill cap and remove the cap from the fuel tank. Insert a clean funnel into the fuel tank.
- Fill the tank to 1/2 inch below the bottom of the filter neck to provide space for any fuel expansion.
- Reinstall the fuel fill cap securely and wipe up any spilled gasoline.
- Store fuel in containers specifically designed for these purposes.
- Turn control valve on engine off when not using or transporting.

MAINTENANCE & STORAGE

- Keep all nuts, bolts, and screws tight to be sure equipment is in safe working condition.
- Never store the equipment with fuel in the tank inside a building where fumes may reach an open flame or spark.
- Allow the engine to cool before storing in any enclosure.
- To reduce fire hazard keep engine, silencer, battery compartment, and fuel storage area free of grease and leaves.
- Check the catcher frequently for wear or deterioration.
- Replace worn or damaged parts for safety.
- If the fuel tank has to be drained, it should be done outside.

SAVE THESE INSTRUCTIONS

SAFETY DECALS

WARNING - IMPORTANT SAFETY INSTRUCTIONS

- USE ON GRASS SURFACES ONLY.
- DRAG STRIP AND GUARDS MUST BE IN PLACE.
- KEEP HANDS AND FEET CLEAR OF LOWER HOUSING DURING OPERATION.
- TO BACK-UP OR TO MAKE TURNS, PUSH DOWN ON HANDLE TO MANUEVER ACCORDINGLY. KEEP FEET AWAY FROM UNIT.
- WEAR APPROVED SAFETY GLASSES, WORK GLOVES AND HEARING PROTECTION WHEN OPERATING THIS UNIT.
- THE OPERATION OF ANY POWERED MACHINE CAN RESULT IN FOREIGN OBJECTS BEING THROWN BY HIGH SPEED ROTATING PARTS.
- KEEP THE AREA OF OPERATION CLEAR OF ALL PERSONS, PARTICULARLY SMALL CHILDREN AND PETS. KEEP BY-STANDERS AT LEAST 25 FEET AWAY FROM AREA OF OPERATION.
- NEVER LEAVE EQUIPMENT UNATTENDED WHEN ENGINE IS RUNNING. SHUT-OFF ENGINE AND DISCONNECT SPARK PLUG WIRE FROM SPARK PLUG BEFORE LEAVING EQUIPMENT.

715305

DO NOT OPEN OR REMOVE SAFETY SHIELDS WHILE ENGINE IS RUNNING

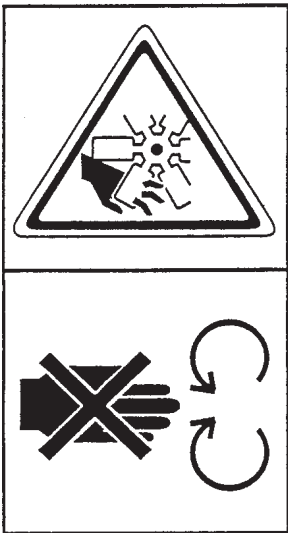

715300

KEEP A SAFE DISTANCE FROM THE MACHINE



715301

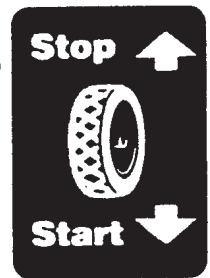

715302

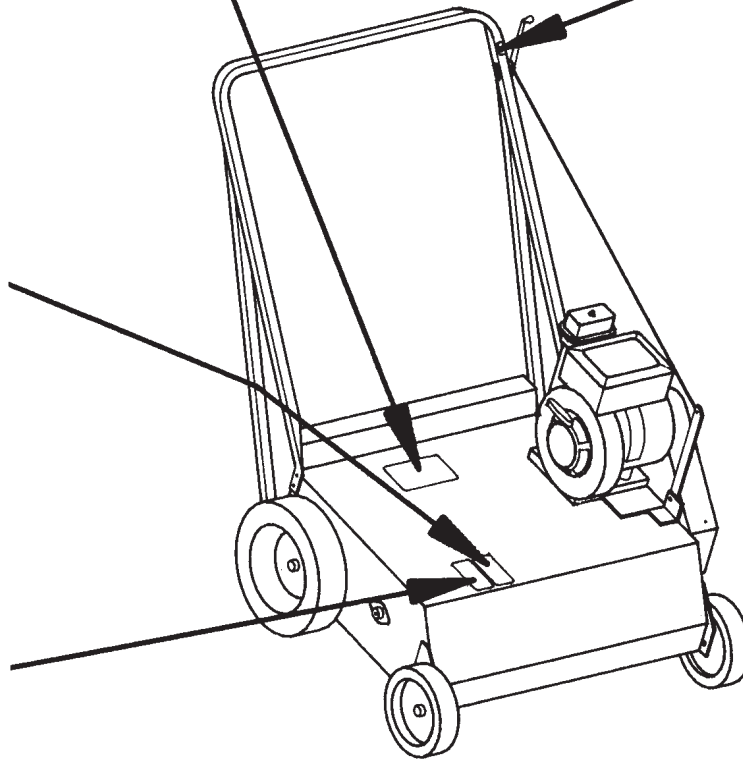

ASSEMBLY INSTRUCTIONS

The Thatch-O-Matic is shipped complete in one box. Remove all items from the carton. DO NOT discard the carton or any inserts until the unit is completely assembled. All hardware is on the unit in its proper location. If something is missing, please notify the dealer/distributor where unit was purchased. If unable to purchase parts locally, contact the Parker Sweeper Company.

The left or right hand side of the machine is determined when standing behind the unit in the operator's position. Make sure spark plug wire is disconnected before continuing these instructions.

1. Remove four hex nuts, lockwashers and contour hd. bolts from lower end of upper handle.
2. Place upper handle down over small diameter end of lower handles.
3. Align lower holes in upper handle and lower handle, insert contour hd. bolt through each hole.
4. Lift handle back brace on each side so it is assembled to contour hd. bolt. Assemble one lockwasher and hex nut to each bolt. Do Not Tighten.
5. Insert remaining contour hd. bolts through upper holes of upper and lower handles.
6. Assemble lockwashers and hex nuts to upper contour hd. bolts and tighten all nuts.

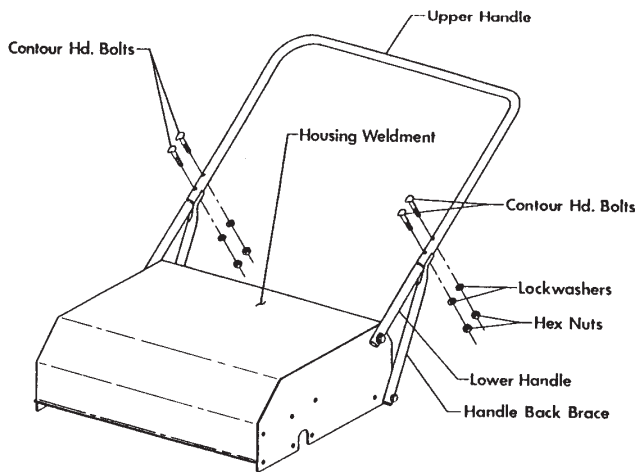

HANDLE ASSEMBLY

1. Remove throttle control from its shipping position.
2. Straighten the throttle cable out and run it up the right hand side of upper handle.

3. Attach the throttle control to the upper handle with the two oval hd. screws and hex nuts furnished.
4. Place clamp onto handle to secure throttle cable. NOTE: Make sure no bends are less than 8" radius.

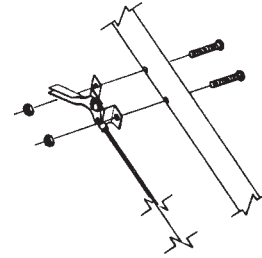

CLUTCH ASSEMBLY

1. Remove clutch control assembly from its shipping position.
2. Remove hex hd. bolt and hex lock nut from curved bracket of assembly.
3. Straighten cable and run clutch control assembly up left hand side of handles.
4. Place curved bracket of clutch control assembly onto upper handle and secure with hardware removed in step 2.
5. Attach clamps to handle to keep cable secure. NOTE: Make sure no bends are less than 8" radius.

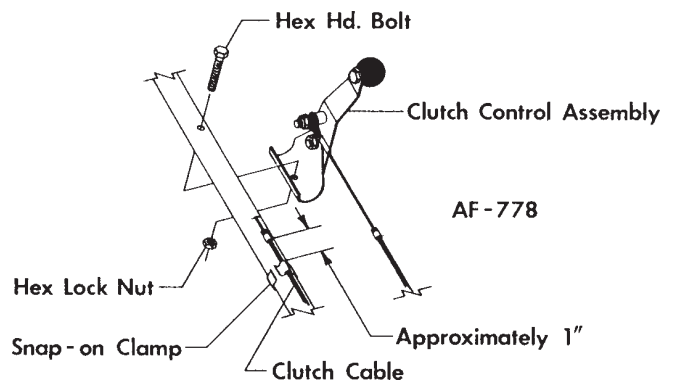

ASSEMBLY INSTRUCTIONS (continued)

ASSEMBLING KNIFE OR FLAIL REEL

1. Remove hex hd. bolts, lockwashers, flatwashers and spacers (where applicable) used to secure belt guard to engine and housing.
2. Remove two hex hd. bolts and lockwashers at reel opening s on both sides of housing.
3. Tip unit back with handles resting on work surface.
4. Lift reel assembly into place making sure all bearing flanges are on the outside of housing.
5. Reassemble lockwashers and hex hd. bolts removed in step 2.
6. Assemble belt to reel sheave making sure belt is still properly seated in engine sheave and inside idler pulley of clutch.
7. It is necessary to check for proper alignment of the belt poppers, to do this:
 - A. Engage the clutch by pulling clutch lever back toward operators position.
 - B. With clutch engaged the gap between the belt and belt poppers should be between $1/16$ and $1/8$ of an inch.
 - C. If not, loosen bolts that secure belt poppers to engine and set to the above dimensions.
 - D. Be careful not to misalign the bracket that holds belt guard. Tighten bolts and disengage clutch.
8. Replace belt guard to engine and housing.

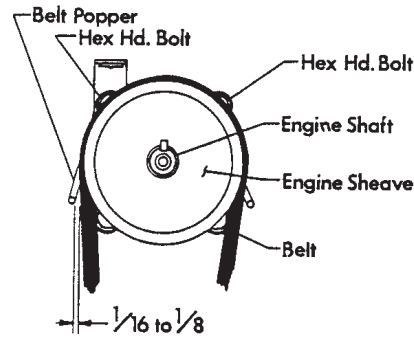
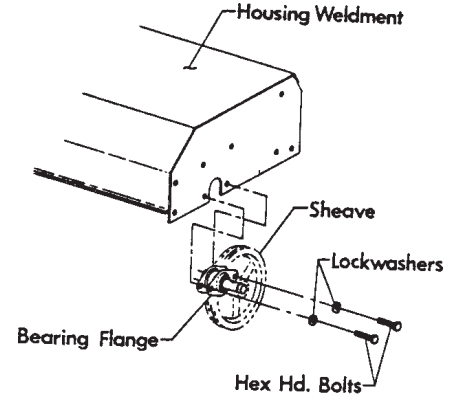

OPERATING INSTRUCTIONS

The Tine Reel assembly is not intended to dig but only to comb the turf and remove dead thatch and help to control creeping weeds in the turf.

It improves fertilizer and seed response, gives grass room to grow, and reduces the likelihood of insects, fungus infestation or dry grass spots. The tines are designed for removing thatch, and if allowed to penetrate the soil for a prolonged period of time, will cause premature fatiguing, bending and breakage.

Should it be desirable to depopulate and aerate, the Knife Reel should be used. If complete renovation and soil penetration is desirable, use Flail Reel.

The Flail Reel assembly should be used if complete turf renovation and soil penetration is desirable to aid in fertilizing and seeding programs. This helps to limit water run-off and retain soil moisture.

The Knife Reel should be used to eliminate hard surface soil. It slices, thins and aerates all types of turf, and allows moisture and fertilizer to reach grass roots. The knife reel is especially effective for thinning running stem grasses, cutting slits in soil prior to overseeding and aerating soil.

Thatch is an accumulation of roots, stems and grass clippings that result in a dense mat between the soil and the visible green vegetation. Often several inches thick, thatch prevents the penetration of fertilizers and water. Every time you mow, thatch builds up. Without proper care thatch can destroy a beautiful lawn.

REEL HEIGHT ADJUSTMENT

1. Move latch weldment up and pull lever in front axle weldment out of the hole setting on adjusting bracket, to a hole setting of your choice.
2. This unit is capable of providing eight different height levels. See illustration and chart below for proper height adjustment.

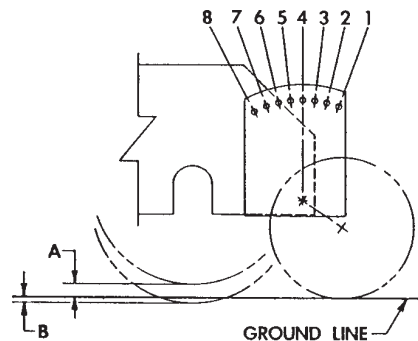

REEL SETTINGS		
HOLE	A	B
1	7/8	
2	3/4	
3	5/8	
4	1/2	
5	3/8	
6	1/4	
* 7	0	0
* 8		1/4

* DO NOT USE FOR TINE REEL.

CLUTCH OPERATION

Clutch is engaged when clutch lever is pulled fully back toward operators position and disengaged when fully forward. This is a spring loaded self-adjusting clutch, no adjustment is needed.

OPERATING INSTRUCTIONS

READ SAFETY OPERATING INSTRUCTIONS BEFORE OPERATING EQUIPMENT

TO START UNIT

IMPORTANT: Before starting the engine, read the Engine Instruction Manual and add gasoline and oil as required.

1. Be sure that the spark plug wire is attached to the spark plug and not grounded to the engine
2. Open the throttle about halfway, close the choke and pull the starter rope.
3. After the engine starts, open the choke or the engine will stall.
4. Engage clutch to activate reel.

CAUTION: Be sure clutch is disengaged and the reel has come to a complete stop before making any change in the direction of the unit. This will eliminate the risk of over travel and possible accidents.

WARNING: Allow engine to cool 2 or 3 minutes before refueling. Fuel spilled on a hot engine could ignite, resulting in serious damage to the unit and possible injury to the operator.

TO STOP ENGINE

Disengage clutch, place throttle and choke to the closed position.

SERVICING AND OPERATING INSTRUCTIONS

Refer to Engine Manufacturer's Service Manual. Careful attention to care of air cleaner and crankcase lubrication instructions will insure longer engine life. **KEEP ENGINE CLEAN.**

DANGER: Reel assemblies are not interchangeable! To replace reel assemblies, it is necessary to replace the engine pulley and belt noted for that assembly, to assure correct reel speed.

CAUTION: Excess reel speed may cause serious injury or damage. Maximum reel speed, tines 900 rpm - flails or knives 1800 rpm.

MAINTENANCE INSTRUCTIONS

1. Be sure to keep the oil at the proper level in the engine. Check the oil level each time you fill the fuel tank.
2. Change the oil after first five hours of operation. There after, change every 25 hours of operation.
3. The engine may require minor carburetor adjustments to compensate for differences in fuel, temperature, altitude or load. See section titled ADJUSTMENTS in the engine manual.
4. Remember that the engine is air cooled, and in order to operate efficiently, it should be kept clean. Dirt and debris should not be allowed to cover the engine and clog the cooling fans.

CAUTION: Do not operate the power rake without the air cleaner installed properly on the engine. Dust particles in the engine will cause rapid wear of the cylinder walls and piston rings and will result in a rapid loss of power.

5. The reel bearings and idler pulley bearings are permanently lubricated and sealed. They require no further attention.

LUBRICATION

1. A few drops of light oil on the throttle control, lever and cable, will keep it operating smoothly.
2. Refer to Engine Operating Manual for proper lubrication of the engine.
3. Add a few drops of oil to wheel axles between spacers and wheels to keep wheels properly lubricated.

CAUTION: Do not work on Thatch-O-Matic with engine running or idling. Bring to a DEAD STOP. Remove spark plug wire from the plug and ground it to the clip provided on the engine head.

HOUSING & WHEEL ASSEMBLY

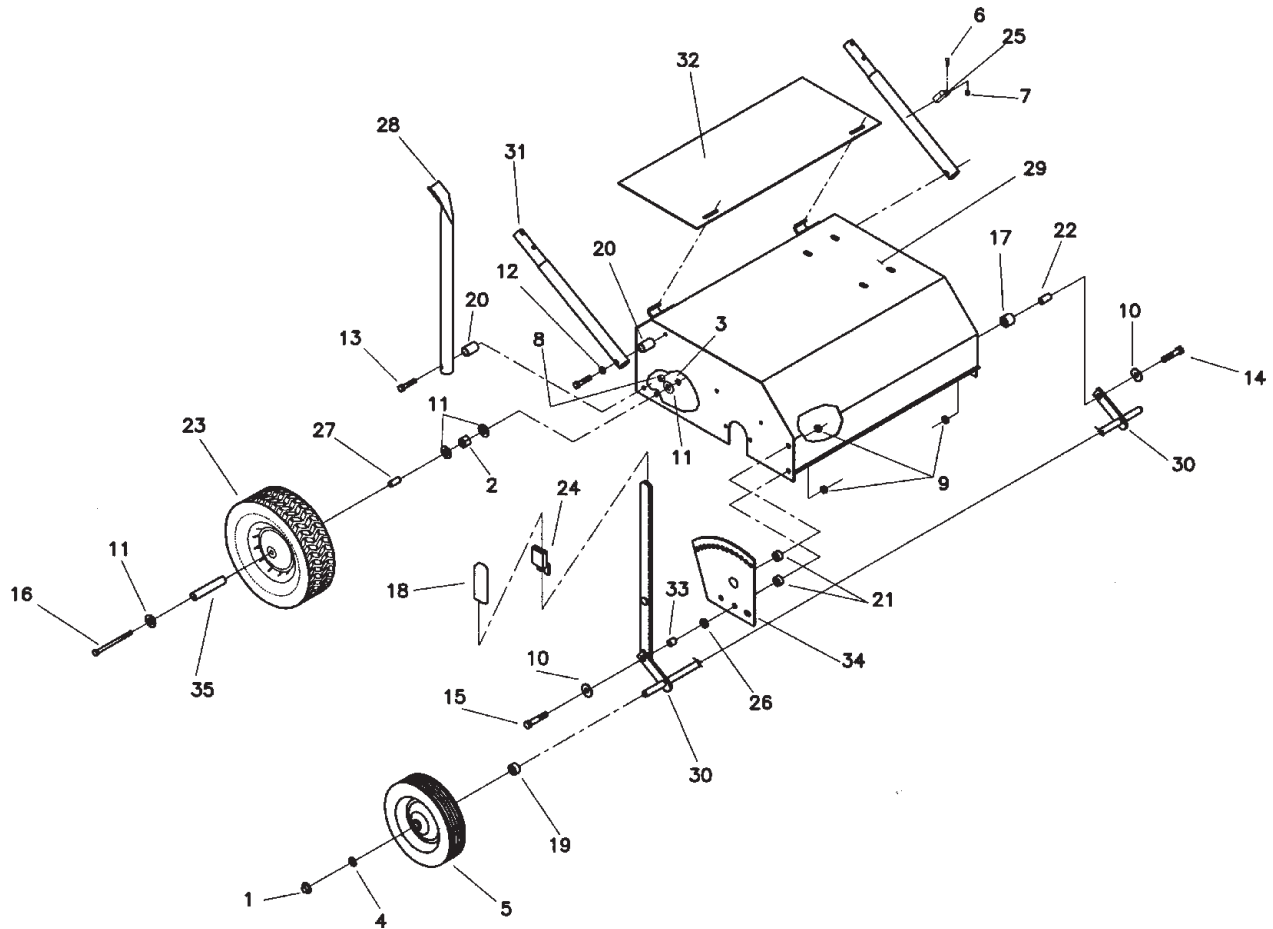

PARTS LIST

ITEM	PART NO.	REQ'D	DESCRIPTION	ITEM	PART NO.	REQ'D	DESCRIPTION
1	130032	2	CAP, RETAINER	19	79-16-A	2	SPACER-CLUTCH
2	326-816	2	NUT-HEX	20	80-238-A	4	BUSHING-.437 OD X 1.00 L ZINC
3	368-816	2	NUT-NYLOC HALF 1/2-20	21	83-181-A	2	SPACER-.413 X .75 X .39
4	46-81-A	2	WSR-SPECIAL	22	83-193-A	1	SPACER-.384 X .50 X .97
5	70-69-A	2	WHEEL-FRONT	23	84-137-C	2	WHEEL (NO HOLES IN HUB)
6	710130	1	SCR-MC 8-32 X .62 NICKEL	24	85-99-B	1	LATCH WELDMENT
7	711372	1	NUT-NYLOC 8-32	25	86-59-B	1	CLAMP CABLE /CLUTCH
8	711374	2	NUT-NYLOC 5/16-18	26	86-86-A	1	SPACER-.391 X .75 X .156
9	711375	3	NUT-NYLOC 3/8-16 1/2NUT	27	86-118A114	2	SPACER-AXLE
10	711507	2	WSR-FLT .37 X 1.12 X .06	28	88-94-C	2	HANDLE BACK BRACE
11	711509	8	WSR-FLT 1/2	29	89-119-D	1	HOUSING WELDMENT
12	711545	2	WSR-HELICAL 5/16	30	89-121-C	1	AXLE FRONT WELDMENT
13	713029	4	BLT-HH 5/16-18 X 1 1/2 #5	31	89-136-B	2	LOWER HANDLE
14	713045	1	BLT-HH 3/8-16 X 1.75 #5	32	89-143-C	1	DRAG STRIP
15	713046	1	BLT-HH 3/8-16 X 2.00 #5	33	89-84-A	1	SPACER-.386 X .50 X .56
16	713067	2	BLT-HH 1/2-20 X 5.00 #5	34	90-01-C	1	ADJUST BRACKET WELDMENT
17	73-414-A	1	SPACER .513 X .875 X .750	35	90-31	2	SPACER-.527 X .625 X 3.40
18	76-80-A	1	GRIP-LEVER				

ENGINE & DRIVE ASSEMBLY

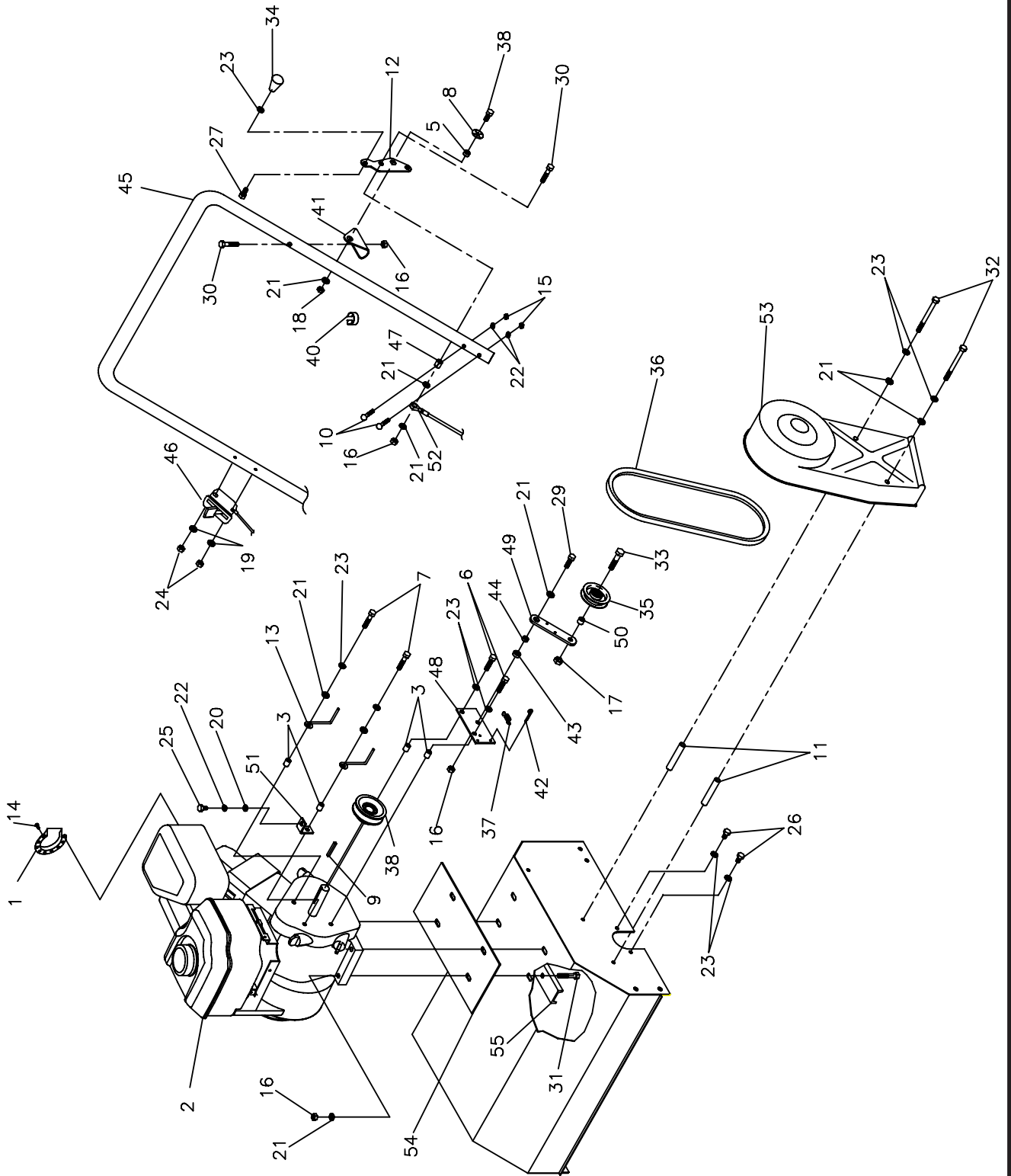

ENGINE & DRIVE ASSEMBLY

PARTS LIST

ITEM	PART NO.	REQ'D	DESCRIPTION	ITEM	PART NO.	REQ'D	DESCRIPTION
1	350264	1	DEFLECTOR-EXHAUST 6.5 B/S	30	713029	2	BLT-HH 5/16-18 X 1 1/2 #5
2	360024	1	ENGINE, 6.0 HP B/S POWERBUILT	31	713030	4	BLT-HH 5/16-18 X 1 3/4 #5
3	51-23-A	4	SPACER-.337 X .437 X .53	32	713037	2	BLT-HH 5/16-18 X 3.5 #5
4	515-10-24	2	SCR-RD HD 10-24 X 1 1/2	33	713045	1	BLT-HH 3/8-16 X 1.75 #5
5	59-29-A	1	SPACER-.328 X .50 X .25	34	760592	1	KNOB-OVAL TAPERED
6	60-516-20	2	BLT-HH 5/16-24 X 1.25 #5	35	76-456-A	1	CLUCH PULLEY AS REC
7	60-516-24	2	BLT-HH 5/16-24 X 1.5 #5	36	77-01-A**	1	BELT (TINE UNIT ONLY)
8	68-28-A	1	SPRING-WSR CUPPED	36A	89-134-A***	1	BELT (KNIFE & FLAIL UNITS)
9	68-137-A	1	KEY	37	77-19-A	1	SPRING-LE-045D-2
10	69-416-24	4	BLT-CONT HEAD 1/4-20 X 1.50	38	77-62-A	1	SHEAVE (TINE UNIT ONLY)
11	70-46-A	2	SPACER-BELT GUARD	38A	89-133-B	1	SHEAVE (KNIFE & FLAIL UNITS)
12	70-67-A	1	SHIFT LEVER	39	711008	1	SET SCREW 5/16-18 X 1/4
13	70-71-A	2	BELT POPPER	40	80-276-A	2	SNAP MOUNT
14	711116	3	SCR-ST-A 10 X .37 ZINC	41	80-285-A	1	BRKT-PR
15	711316	4	NUT-HEX 1/4-20 ST PL	42	809311	1	PIN-COTTER 7/64 X 1
16	711374	7	NUT-NYLOC 5/16-18	43	81-120-A	1	SPACER .316X.626X.210
17	711375	1	NUT-NYLOC 3/8-16 1/2NUT	44	82-135-A	1	SPACER-.316 X .498 X .197
18	711420	1	NUT-HEX JAM 5/16-18 STPL	45	83-06-C	1	UPPER HANDLE
19	711503	2	WSR-FLT #10	46	83-25-B-44	1	CABLE-THROTTLE ASSY
20	711505	1	WSR-FLT 1/4	46A	83-25-B-36	1	CABLE-THROTTLE ASSY
21	711506	12	WSR-FLT 5/16 (NARROW) ST PL	47	81-42-A	4	SPACER-.327 X .495 X .280
22	711544	5	WSR-HELICAL 1/4	48	87-236-B	1	MOUNTING PLATE
23	711545	11	WSR-HELICAL 5/16	49	87-238PLT	1	CLUTCH PLATE PLATED
24	712638	2	NUT HEX 10-24 SS NYLOC	50	87-239-A	1	SPACER-.384 X .50 X .375
25	713000	1	BLT-HH 1/4-20 X .50 #5	51	88-41-A	1	BRACKET-WELDMENT
26	713024	4	BLT-HH 5/16-18 X 1/2 #5	52	89-138-A	1	CABLE ASSY
27	713025	1	BLT-HH 5/16-18 X 5/8 #5	53	90-07-C	1	BELT GUARD
28	713026	1	BLT-HH 5/16-18 X 3/4 #5	54	90-12	1	MOUNTING PLATE
29	713027	1	BLT-HH 5/16-18 X 1 #5	55	90-13	1	STIFFENER
				56	711379	2	NUT-FLANGED WIZZ 5/16-18

** Gates Vee Belt #A35 NO SUBSTITUTES

*** Gates Vee Belt #A37 NO SUBSTITUTES

TINE REEL ASSEMBLY

NOTE: THE TINE REEL ASSEMBLY IS NOT DESIGNED FOR DIGGING OR RENOVATING AND SHOULD NOT BE SET LOWER THAN CONTACT WITH FLAT (HARD) SURFACE SUCH AS SIDEWALK OR DRIVEWAY. THIS MEANS TOUCH, NOT SCRATCH OR DIG INTO SURFACE.

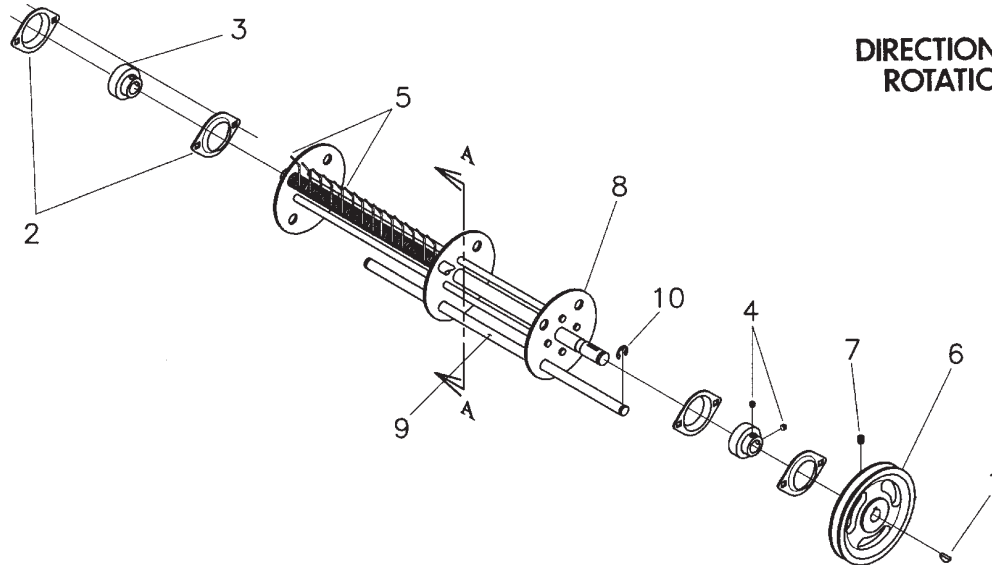
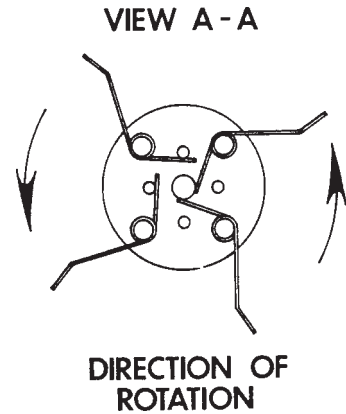

PARTS LIST

ITEM	PART NO.	REQ'D	DESCRIPTION
1	280-9	1	KEY-SHAFT
2	340742	4	BEARING-FLG ZINC
3	66-138-A	2	BEARING
4	*	4	SCREW, ALLEN HD. SET 1/4-28x1/4
5	66-238-A-1	1	TINE SPRING- BOX OF 101
6	76-377-B	1	SHEAVE
7	**	1	SCREW, ALLEN HD. SET 5/16-18x3/8
8	83-44-C	1	TINE SHAFT ASY
9	83-45-A	4	ROD SPRING
10	89-124-A	8	E RING

* Supplied with item 3

** Supplied with item 6

Can be purchased as a complete assembly, part no. MA-553-D, less items 1, 6, and 7.

KNIFE REEL ASSEMBLY

VIEW A-A

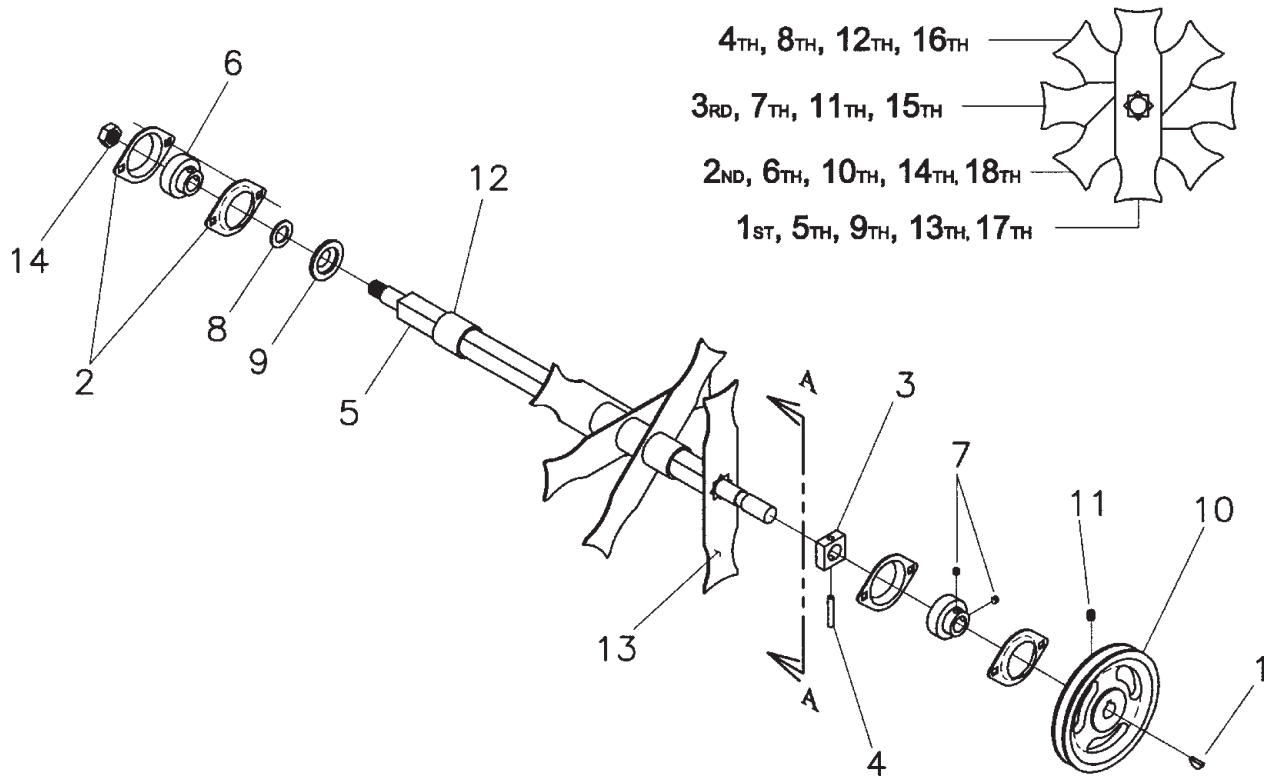

PARTS LIST

ITEM	PART NO.	REQ'D	DESCRIPTION
1	280-9	1	KEY-SHAFT
2	340742	4	BEARING-FLG ZINC
3	66-43-A	1	COLLAR
4	66-44-A	1	PIN-SPIRAL STL
5	66-48-B	1	SHAFT KNIFE REEL
6	66-138-A	2	BEARING
7	*	4	SCREW, ALLEN HD. SET 1/4-23 X 1/4
8	66-431-A	1	WSR-SPECIAL
9	71-40-A	1	WASHER WELDMENT
10	76-377-B	1	SHEAVE
11	**	1	SCREW, ALLEN HD. SET 5/16-18 X 3/8
12	809248	9	SPACER
13	87-74-B	10	KNIFE BLADE
14		1	NUT, HEX LOCK (THIN) 5/8-18

* Supplied with item 6

** Supplied with item 10

Can be purchased as a complete assembly, part no. MA-683-D.

FLAIL REEL ASSEMBLY

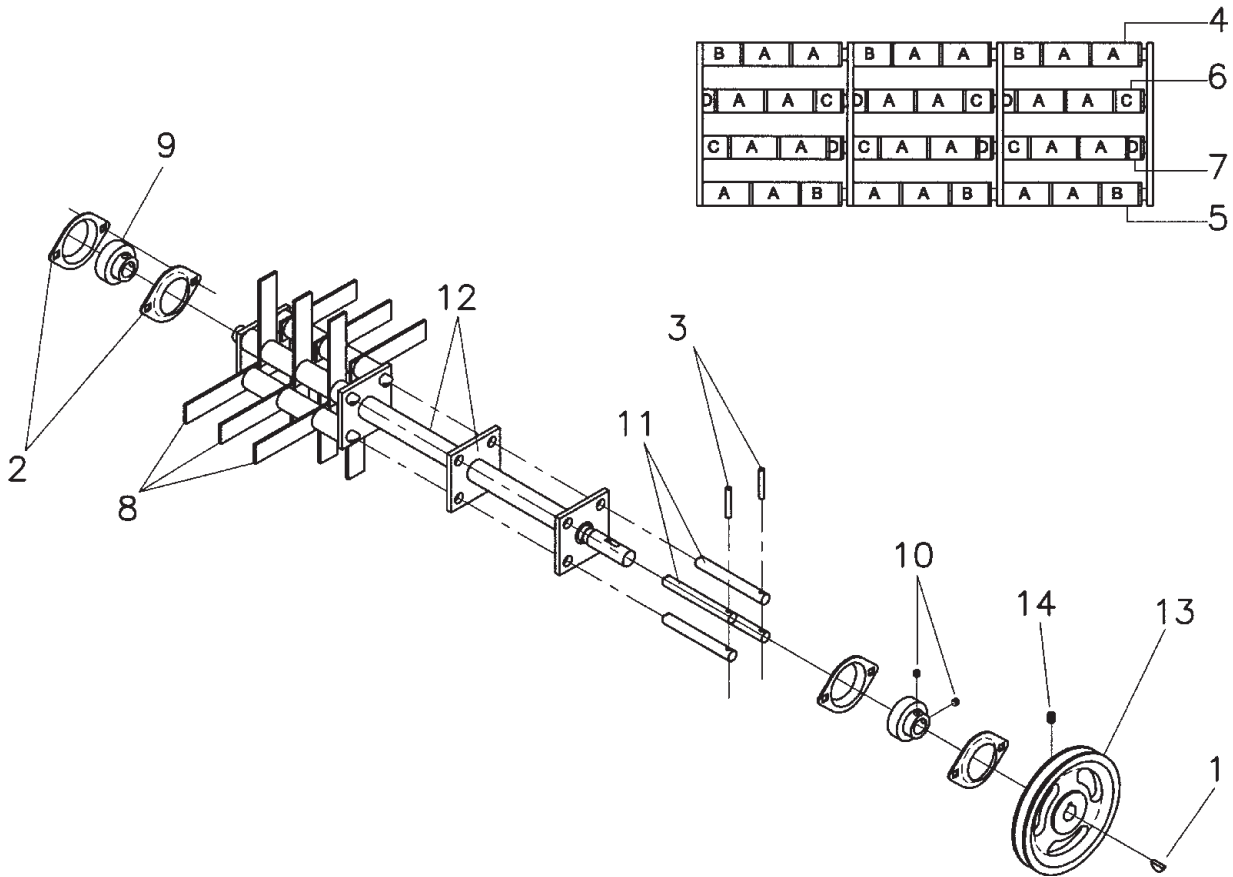

PARTS LIST

ITEM	PART NO.	REQ'D	DESCRIPTION
1	280-9	1	KEY-SHAFT
2	340742	4	BEARING-FLG ZINC
3	57-97-A	8	PIN-ROLL
4	66-52-A	24	SPACER-.625 X 1.00 X 1.984
5	66-53-A	6	SPACER-.625 X 1.00 X 1.594
6	66-54-A	6	SPACER-.625 X 1.00 X 1.062
7	66-55-A	6	SPACER-.625 X 1.00 X .50
8	66-56-A	36	THATCHING BLADE
9	66-138-A	2	BEARING
10	*	4	SCREW, ALLEN HD. SET 1/4-23 X 1/4
11	70-48-A	4	ROD FLAIL REEL
12	70-52-B	1	FLAIL REEL WELDMNT
13	76-377-B	1	SHEAVE
14	**	1	SCREW, ALLEN HD. SET 5/16-18 X 3/8

* Supplied with item 9

** Supplied with item 13

Can be purchased as a complete assembly, part no. MA-683-D

LIMITED WARRANTY

The Parker Sweeper Company warrants to the original purchaser/user that this product is free from defects in workmanship and materials under normal use and service for a period of two years from date of purchase. In addition, Parker Sweeper Company will, at its option, honor labor warranty claims for the first 12 months from date of sale, provided such claims are submitted through and approved by factory authorized repair stations. Parker Sweeper Company will, at its option, repair or replace without charge, except for transportation costs, parts that fail under normal use and service when operated and maintained in accordance with the applicable operation and instruction manuals.

This warranty does not apply to normal wear, or to items whose life is dependent on their use and care, such as belts, cords, switches, hoses, rubber parts, electrical motor components or adjustments. Parts not manufactured by Parker Sweeper Company such as engines, batteries, battery chargers, hydraulic pumps, and tires are covered by and subject to the warranties and/or guarantees of their manufacturers. Please contact Parker Sweeper Company for procedures in warranty claims against these manufacturers.

Special warning to purchaser — Use of replacement filters and/or prefilters not manufactured by Parker Sweeper Company or its designated licensees, will void all warranties expressed or implied.

A potential health hazard exists without exact original equipment replacement.

All warranted items become the sole property of Parker Sweeper Company or its original manufacturer, whichever the case may be.

Parker Sweeper Company disclaims any implied warranty, including the warranty of merchantability and the warranty of fitness for a particular purpose. Parker Sweeper Company assumes no responsibility for any special, incidental or consequential damages.

This limited warranty is applicable only in the U.S.A. and Canada, and is extended only to the original user/purchaser of this product. Customers outside the U.S.A. and Canada should contact their local distributor for export warranty policies. Parker Sweeper Company is not responsible for costs or repairs performed by persons other than those specifically authorized by Parker Sweeper Company. This warranty does not apply to damage from transportation, alterations by unauthorized persons, misuse or abuse of the equipment, use of non-compatible chemicals, or damage to property, or loss of income due to malfunctions of the product.

If a difficulty develops with this machine, you should contact the dealer from whom it was purchased.

This warranty gives you specific legal rights, and you may have other rights which vary from state to state. Some states do not allow the exclusion or limitation of special, incidental or consequential damages, or limitations on how long an implied warranty lasts, so the above exclusions and limitations may not apply to you.

Minuteman[®]
Parker[®]

Minuteman International, Inc.
111 South Rohlwing Road
Addison, Illinois 60101

Phone 630-627-6900
Fax 630-627-1130
www.minutemanintl.com

988224
REV * 01/07
Printed in U.S.A.