

CHAPTER 2

MAINTENANCE / TUNE UP

Maintenance Schedule, 500 Mile	2.1
Maintenance Schedule, 1500 Mile	2.2
Recommended Maintenance Products	2.3
Intake Filter	2.4
Lubrication	2.5
Water Pump Belt - Domestic	2.6
Water Pump Belt - Fuji	2.7
Chaincase	2.8-2.9
Suspension Lubrication	2.10-2.11
Cooling System	2.12
Track Maintenance/Alignment	2.13-2.17
Spark Plugs	2.18
Drive Belt Removal/Installation	2.19
Backrest Adjustment	2.20
Headlight Adjustment	2.21-2.22
Bulb Replacement	2.22
Handlebar Adjustment	2.23
Brakes	2.24-2.26
Reverse Maintenance	2.27-2.28
Off Season Storage	2.29-2.31
Variable Exhaust Systems	2.32-2.34
Routing Diagrams	2.35-2.71

MAINTENANCE/TUNE UP Maintenance Schedule

500 Mile (805 km) Initial Maintenance Inspection

- __1. Check cylinder head and base area for signs of exhaust or coolant leaks.
- __2. Re-torque cylinder heads (cold) & cylinder base nuts
- __3. Check ignition timing
 - _____ observed BTDC
 - _____ corrected BTDC
- __4. Check clutch offset (belt removed)
- __5. Check belt condition
- __6. Check and adjust belt tension
- __7. Inspect rubber engine mounts
- __8. Torque engine mounting plate to chassis fasteners
- __9. Adjust engine torque stop (if equipped)
- __10. Carburetor Inspections
 - A. Adjust choke plungers
 - B. Adjust pilot air screw
 - C. Synchronize carburetor slide valves at idle and off idle
 - D. Adjust engine idle RPM
 - E. Adjust throttle lever free play
 - F. Synchronize oil pump lever
 - G. Inspect choke/throttle cables
 - H. Inspect vent lines for wear or kinking
- __11. Check ski toe alignment
- __12. Torque and inspect all steering fasteners
- __13. Torque suspension-to-tunnel mounting bolts
- __14. Check rear suspension fasteners for tightness
- __15. Adjust track tension and align track
- __16. Remove chaincase cover, flush chaincase, inspect and adjust chain, refill with new chaincase oil.
- __17a.Brakes-Hydraulic
 - A. Check brake fluid level.
 - B. Check for proper hose routing; tightness of banjo bolts and line fasteners.
 - C. Check for system fluid leaks.
 - D. Visually inspect pads for wear damage or looseness.
 - E. Check security and surface condition of brake disc.
- __17b.Brake-Mechanical
 - A. Check cable condition / routing.
 - B. Check brake pad and brake disc condition and mounting.
 - C. Adjust brake to proper specifications.
- __18. Check auxiliary shut-off switch.
- __19. Perform throttle safety switch tests.
- __20. Check brake light for proper operation.
- __21. Check tail lights.
- __22. Check headlamp fasteners and high-low beam operation.
- __23. Liquid cooled models:
 - A. Check coolant level and specific gravity.
 - B. Check water pump drive belt condition & deflection (where applicable).
 - C. Check coolant hose, routing and clamps.
 - D. Inspect heat exchangers condition and fasteners.
 - E. Check cooling system for proper coolant circulation.
- __24. V.E.S. (Variable Exhaust System) - if applicable.
 - A. Disassemble and clean components.
- ___ ACCS
 - A. Inspect vent lines, clamps.

Recommendations

Polaris Service Technician _____

Base Inspection Price _____

Authorized Dealer _____

Parts _____

Date _____

Labor _____

MAINTENANCE/TUNE UP

Maintenance Schedule

1500 Mile (2400 km) Maintenance Inspection

- ___1. Check cylinder head and base area for signs of exhaust or coolant leaks.
- ___2. Re-torque cylinder heads & cylinder base nuts (cold).
- ___3. Check compression and record readings.
- ___4. Check ignition timing.
 - ___ observed BTDC
 - ___ corrected BTDC
- ___5. Inspect recoil starter rope..
- ___6. Check drive to driven clutch offset (belt removed).
- ___7. Remove clutches, disassemble & inspect all wear surfaces. Clean sheaves, repair clutch as necessary, reassemble clutches and torque to specifications.
- ___8. Check belt condition.
- ___9. Check and adjust belt deflection.
- ___10. Inspect rubber engine mounts.
- ___11. Torque engine mounting plate to chassis fasteners.
- ___12. Adjust engine torque stop (if equipped) (0.10"-0.30").
- ___13. Carburetor Inspections.
 - A. Adjust choke plungers.
 - B. Adjust pilot air screw.
 - C. Synchronize carburetor slide valves at idle and off idle.
 - D. Adjust engine idle RPM.
 - E. Adjust throttle lever free play.
 - F. Synchronize oil pump lever.
 - G. Inspect Choke/Throttle Cables.
 - H. Inspect vent lines for wear or kinking.
- ___14. Remove chaincase cover, flush chaincase, inspect and adjust chain, refill with new chaincase oil.
- ___15. Change primary fuel filter and oil filter.
- ___16. Check fuel and oil line condition and routing.
- ___17. Inspect fuel and oil tank vent lines/routing.
- ___18. Inspect airbox fit/air filter. Clean or replace.
- ___19. Change shock oil (Fox) annually before storage.
- ___20. V.E.S (Variable Exhaust System) - if applicable.
 - A. Disassemble and clean components.
- ___21. ACCS
 - A. Inspect vent lines.
- ___21a. Brakes-Hydraulic
 - A. Check brake fluid level.
 - B. Check for proper hose routing; tightness of banjo bolts and line fasteners.
 - C. Check for system fluid leaks.
 - D. Visually inspect pads for wear damage or looseness.
 - E. Check security and surface condition of brake disc.
 - F. Flush brake fluid and change every two years.
- ___21b. Brake-Mechanical
 - A. Check cable conditions / routing.
 - B. Check brake pad and brake disc condition and mounting.
 - C. Adjust brake to proper specifications.
- ___22. Check auxiliary shut-off switch & perform throttle safety switch tests.
- ___23. Inspect brake light, tail light, oil light and all electrical accessories.
- ___24. Inspect Hi/Lo beam operation and aim headlight; check fasteners.
- ___25. Liquid cooled models:
 - A. Check coolant level and specific gravity.
 - B. Check water pump drive belt condition & deflection (where applicable).
 - C. Check coolant hose, routing and clamps.
 - D. Inspect heat exchangers condition and fasteners.
 - E. Check cooling system for proper coolant circulation.
 - F. Replace recovery line filter: NOTE: Must use correct filter.
 - G. Check coolant recovery line one way check valve (must hold pressure) where applicable.
 - H. Pressure test cooling system.
- ___26. Fan Cooled: Inspect cooling fins and shrouds.
- ___27. Remove chaincase cover, flush chaincase, inspect chain & sprockets and adjust chain. Inspect chaincase seals.
- ___28. Check condition of drive shaft and jackshaft bearings. Lubricate greaseable bearings with Premium All Season grease.
- ___29. Inspect and adjust reverse cable (if applicable).
- ___30. Remove ski pivot bushings and lubricate.
- ___31. Inspect ski wear bars.
- ___32. Check camber alignment and lubricate spindles.
- ___33. Remove radius rod end bushings, lubricate and reinstall, inspect all radius rod ends.
- ___34. Reinstall skis and inspect/adjust toe alignment.
- ___35. Check handlebar centering and lubricate all steering pivots.
- ___36. Torque tie rod end bolts and jam nuts.
- ___37. Inspect steering arms and torque bolts. Inspect handlebar bolt torque.
- ___38. Lubricate rear suspension pivot shafts.
- ___39. Torque suspension mounting bolts and check all rear suspension fasteners and components.
- ___40. Inspect rear suspension wheels, bearings and hi-fax.
- ___41. Inspect track for damage. Adjust tension and alignment.

For optimum performance and reliability, repeat the above maintenance and inspections annually (preferably before off-season storage) or every 1000 miles, except where noted.

RECOMMENDATION: _____

MAINTENANCE/TUNE UP
Recommended Maintenance Products

Recommended Maintenance Products

ENGINE OIL			RETAINING/SEALING PRODUCTS		
Part #	Description	Packaging (size / quantity)	Part #	Description	Packaging (size/quantity)
2871721	Synthetic 2-Cycle Premium Gold	Quarts/ 6	2870652	Fuel Stabilizer	16 oz / 12
2871722	Synthetic 2-Cycle Premium Gold	Gallon / 4	2872280	Fuel Stabilizer	2.5 Gallon / 2
2871723	Synthetic 2-Cycle Premium Gold	16 Gallon Drum	2871027	Corrosion Resistant DiElectric Grease	2 oz
2871884	Synthetic 2 Cycle Premium Gold	55 Gallon Drum	2871064	T-9 Metal Protectant	each
2871098	Premium 2-Cycle Oil (TC-W3)	Quart Cans / 12	2870632	Metal Polish	10 oz / each
2871097	Premium 2-Cycle Oil (TC-W3)	Gallon / 6	2871076	Battery Tender™	8 oz
2871240	Premium 2-Cycle Oil (TC-W3)	2.5 Gallon / 2	2870585	Primer N, Aerosol	25 gr / 1
2871566	Premium 2-Cycle Oil (TC-W3)	16 Gallon Drum	2870584	680 Retaining Compound	10cc / each
2871385	Premium 2-Cycle Oil (TC-W3)	30 Gallon Drum	2871949	Threadlock 242	50cc / 10
2871096	Premium 2-Cycle Oil (TC-W3)	55 Gallon Drum	2871950	Threadlock 242	6cc / 12
2871281	Premium-4 Synth. 4 Cycle Oil (0W-40)	Quarts/ 12	2871951	Threadlock 262	50cc / 10
2871567	Premium-4 Synth. 4 Cycle Oil (0W-40)	16 Gallon Drum	2871952	Threadlock 262	6cc / 12
2871844	Premium-4 Synth. 4 Cycle Oil (0W-40)	Gallon/ 4	2871953	Threadlock 271	6cc / 12
2871818	Premium-4 Synth. 4 Cycle Oil (0W-40)	55 Gallon Drum	2871954	Threadlock 271	36cc / 6
MAINTENANCE PRODUCTS			2871955	Instant Adhesive: Prism 401	3cc / 30
2871326	Carbon Clean Plus	12 oz / 12	2871956	Pipe Sealant 565	50cc / 6
2871478	Premium Synthetic Gearcase Lube	12 oz / 12	2871957	Silicone, Black RTV	3 oz tube / 12
2871477	Premium Synthetic Gearcase Lube	Gallon / 4	2871958	Silicone, Black RTV	11 oz Cartridge/12
2872275	Premium Synthetic Gearcase Lube	2.5 Gallon / 2	2871959	Ultra Blue RTV	3.35 oz / 12
2871280	Chain Case Lubricant	Quart / 12	2871960	Ultra Blue RTV	13 oz Cartridge/12
2870464	Chain Case Lubricant	Gallon / 6	2871961	518 Flange Sealant	50cc / 10
2871323	Premium Antifreeze 60/40 Premix	Gallon / 6	CRANKCASE SEALANTS		
2871534	Premium Antifreeze 60/40 Premix	Quart / 12	2870587	518 Gasket Eliminator	50cc
2870995	Premium Gas Shock Oil	Quart / 6	2871557	3 Bond 1215	5oz
2872279	Premium Gas Shock Oil	2.5 Gallon / 2	VALUE PACKS		
2870990	Premium Brake Fluid DOT-3	12 oz / 12	2871967	Synthetic Lube Value Pack	4 / Value pack
2870791	Premium Fogging Oil (spray)	12 oz / 12	2871593	TC-W3 Lube Value Pack	4 / Value pack
2871517	Premium Fogging Oil (liquid with spout)	Quart / 12	WAX AND POLISH		
2871518	Premium Fogging Oil (liquid)	Gallon / 6	2871589	Revival/Detailing Kit	6 / Kit
2871312	Grease Gun Kit (All Season)	3 oz / 4	2871966	Restore polish/scuff remover	12 / 12 oz.
2871322	Premium All Season Grease	3 oz / 24	2871965	Reflect Wax Final Finish	12 / 12 oz.
2871423	Premium All Season Grease	14 oz / 10	2871964	Renew vinyl rubber protector	12 / 12 oz.
2871460	Premium Starter Grease	2 oz / 12			
2871592	Barrel Pump (for 16/30/55 gal. drums)	Each			
2871285	Flex Spout (fits gal. and 2.5 gal. jugs)	25			
2870505	Isopropyl	10 oz / 24			

MAINTENANCE/TUNE UP

Intake Filter

The intake foam filter limits snow ingestion into the intake system. When operating in loose powder snow, check top of foam filter periodically to remove any accumulation of snow.

CAUTION:

Do not operate machine with the intake filters removed. This can cause carburetor icing resulting in poor fuel economy or carburetor malfunction.

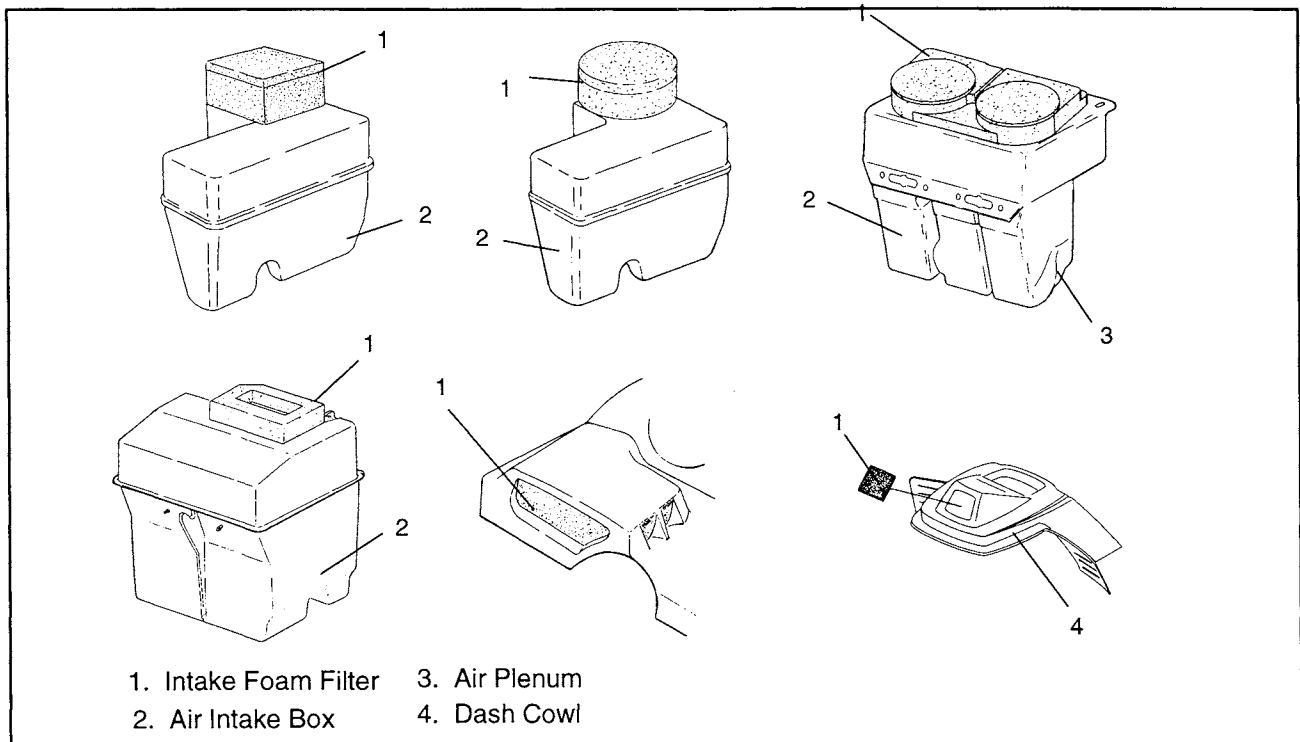

Under Hood Air Intake System

The Indy 340, Indy 340 Deluxe, and Indy 340 Touring are equipped with an under hood air intake system which should normally be left open. The door should be closed and latched above 35° F (2° C) for maximum performance during warm weather operation. Simply pull the strap out and up to latch the door. Reverse the procedure to open it.

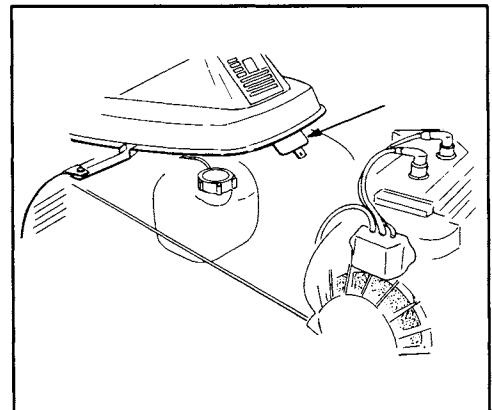

MAINTENANCE/TUNE UP Lubrication

Lubricate the following fittings with Polaris Premium All Season grease annually or approximately every 1000 miles (1600 km). Remove weight from the component being greased to permit better penetration and flushing of the joint.

- Spindles, left and right.
- Rear suspension pivot shafts.
- Lubricate both front ski pivots at fitting as shown using low temperature grease.
- Grease jackshaft and driveshaft (clutch side) bearings.
- Grease steering post support bracket bushings.

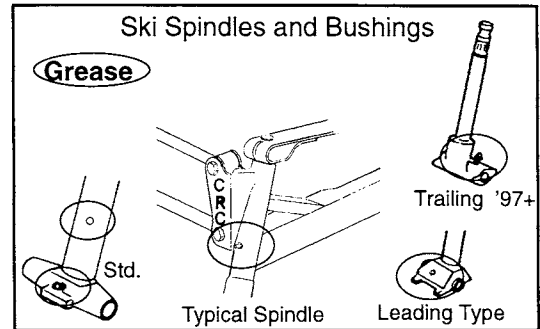

- Grease center steering arm (bell crank), pitman arm, and idler arm (where applicable).

NOTE: A grease gun kit complete with grease and adaptors is available to lubricate all fittings on Polaris snowmobiles.

Polaris Premium All Season Grease
14 oz. PN 2871423

Grease Gun Kit PN 2871312

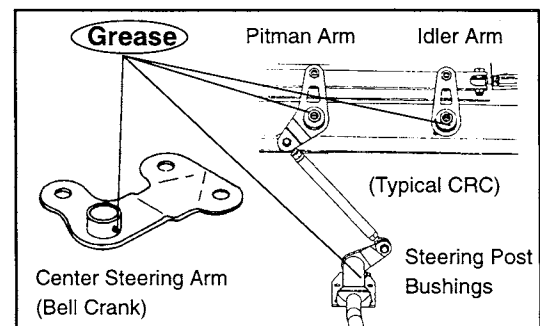

Jackshaft Bearing Greasing

Loosen driven clutch retaining bolt and pull clutch outward to expose bearing. Use a point type grease gun fitting to inject grease through hole in flangette into bearing until grease purges out inside or outside bearing seal. Push clutch back onto shaft and replace clutch retaining bolt.

Grease Gun Adapter: 2871174
Point Type

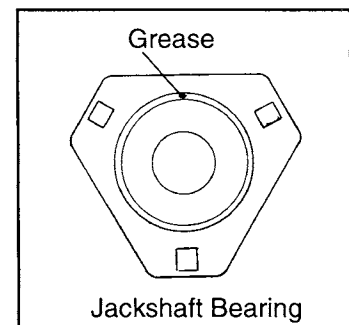

Driveshaft Bearing Greasing

Inject grease into fitting on speedometer drive adaptor until grease purges out inside or outside bearing seal.

Driveshaft Bearing Greasing - WideTrak

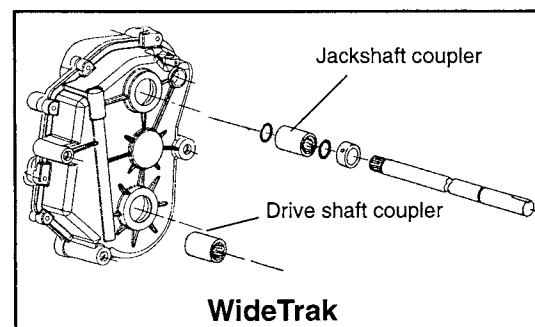

MAINTENANCE/TUNE UP Water Pump

Water Pump Belt Tension - 600 / 700 Domestic Twins

The water pump belt on all 600 & 700 domestic twins snowmobile engines should be inspected every 1500 miles. Belts should be inspected by measuring the width at several locations around the belt. Belt width at any location should not be thinner than .250" (6.35mm). Replace the belt if you notice any loose cords, broken cracked or missing cogs, and variations in width. If the water pump belt fails, serious engine damage could result. Nominal thickness of a new belt should be approximately .345" (8.75mm).

Check belt tension by rotating crankshaft 1/8 turn at a time. The tension should be equal at all points of rotation.

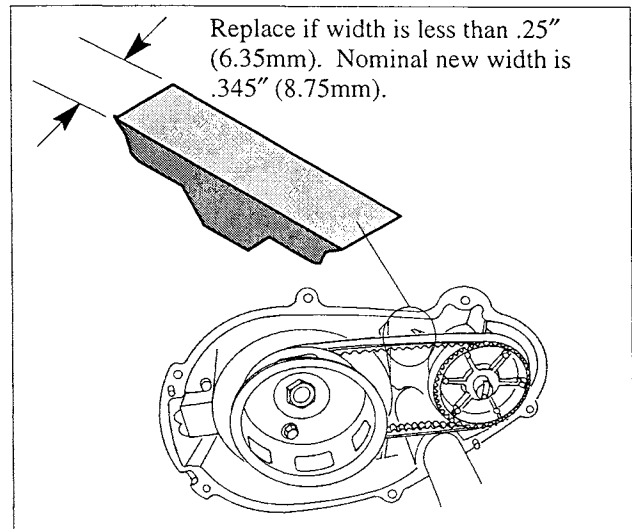

1. A weight is needed to test belt deflection. Construct a weight out of wire and weights such as thick washers. Use the illustration to assist you. The finished weight should weigh 2 lbs.
2. Measure the belt deflection using the following procedure:
 - a. Hang weight midway between pulleys. Weight must hang free and not rest on any part of machine.
 - b. Lay a straight edge or straight piece of stiff material (steel is suggested) across the top of both pulleys. The straight edge should measure approximately 1/8" x 8" x 1".
 - c. Measure the gap between the belt and the straight edge at the point where the weight is hanging.
 - d. Measured distance must be between .1" and .25". If the measured distance is more than the specification, try another waterpump belt.

NOTE: Do not use tools to assemble belt on pulleys. Damage can occur which could shorten belt life. Before installing new belt, check pulley teeth, remove all foreign material, dirt, and oil. Never install a used belt on a different engine. Install belt so writing on the belt can be read from the right side of the machine.

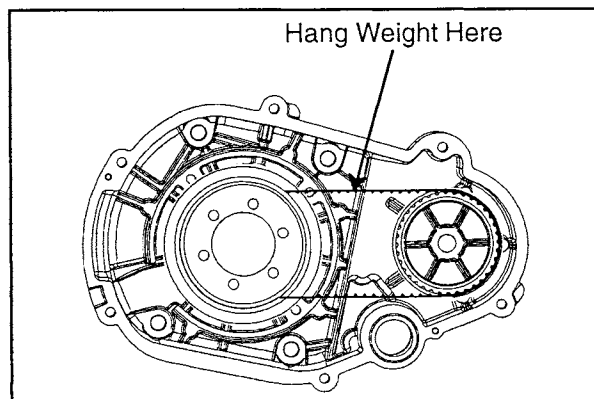
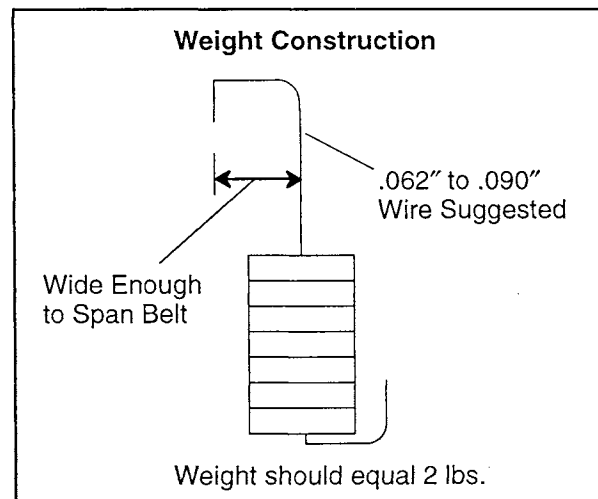

Water Pump Belt Tension - Fuji

Loosen pump mounting bolts. Push on pump housing to apply tension to belt and hold in this position. Tighten pump mounting bolts. Apply light pressure at center of belt span. Check total deflection of belt span and compare to specifications. Re-adjust if necessary.

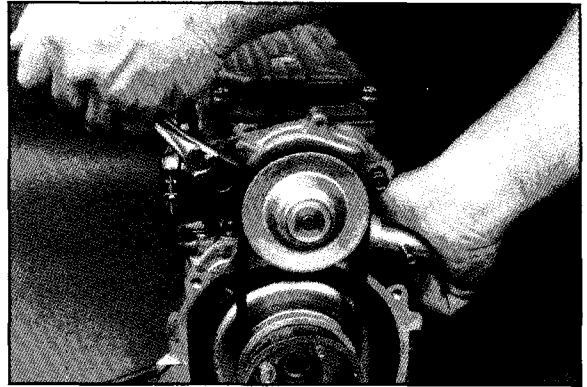

Water Pump Belt Tension

1/8" - 3/16" (3-4mm)

Oil Pump Adjustment

Refer to Page 3.83 for oil pump adjustment procedure.

MAINTENANCE/TUNE UP

Chaincase

Chaincase Oil Level (All Except WideTrak Models)

The Indy models have a silent chain design. The drive chain is continuously immersed in oil. Proper oil level is determined by checking the level on the dipstick with machine placed on a level surface. The oil level should be between the "safe" marks on the dipstick. Add oil through dipstick opening to maintain proper level. Use Polaris synthetic chaincase oil. *Do not overfill.*

Polaris Synthetic Chaincase Lubricant
Gallon PN 2871477
12 oz. PN 2871478

CAUTION:

Polaris Synthetic Chaincase Lubricant is compatible with our petroleum based chaincase oil and can be mixed. However, do not mix or use other types of lubricant. Excessive wear to chain, sprockets and bearings may result.

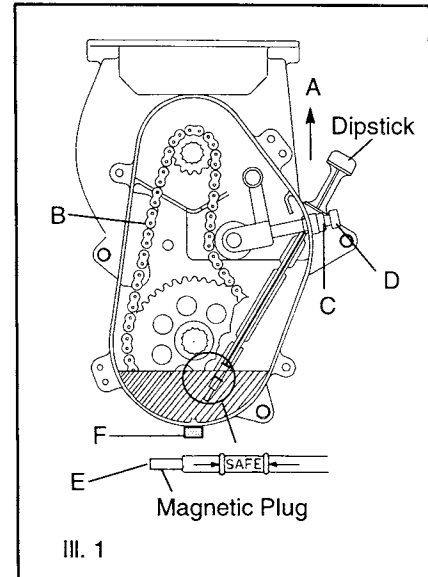

Drive Chain Tension - Chaincase cover on

To obtain correct chain tension:

1. Elevate rear of machine so track is off floor.
2. Loosen locknut and chain adjuster.
3. Back off adjuster bolt 1/2 turn. (For models with reverse, back off adjuster bolt 1 1/4 to 1 1/2 turns)
4. Hold adjuster bolt in position and tighten locknut.

Drive Chain Tension - Chaincase cover removed

To obtain correct chain tension:

1. Remove drain plug (F) and drain oil into a suitable container. Dispose of properly.
2. Remove the chaincase cover.
3. While putting a slight reverse tension on the chain by turning brake disc as indicated by the arrow (A), there should be approximately 1/4-3/8" (.6-1 cm) deflection on the chain at point (B). Refer to illustration 1.
4. The chain is adjusted by loosening the adjusting bolt locknut (C) and turning adjusting bolt (D) until correct chain deflection is obtained.
5. Lock the adjusting bolt locknut (C) while holding a wrench on the adjusting bolt (D) to prevent it from turning.
6. Reinstall the chaincase cover and drain plug. Add Polaris synthetic chaincase lubricant (PN 2871478) through the dipstick opening to the level described above.

NOTE: Clean the magnetic plug (E) every 500 miles (800 km) and whenever checking or changing lubricant.

MAINTENANCE/TUNE UP Chaincase

Chaincase Oil Level (WideTrak Models)

Using Polaris Synthetic Chaincase Lubricant, maintain the proper oil level. Proper oil level is determined by checking the level on the dipstick (A) with the machine placed on a level surface. The oil level should be between the "safe" marks on the dipstick. Add oil through the dipstick opening to maintain proper oil level. *Do not overfill.*

NOTE: Clean the magnetic plug (B) every 500 miles (800 km) and whenever checking or changing lubricant.

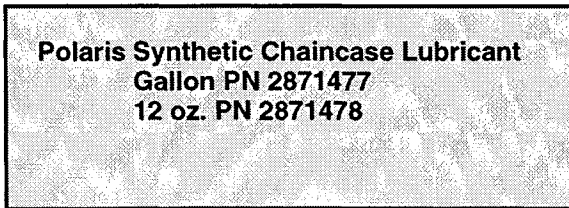

CAUTION:

Polaris Synthetic Chaincase Lubricant is compatible with our petroleum based chaincase oil and can be mixed. However, do not mix or use other types of lubricant. Excessive wear to chain, sprockets and bearings may result.

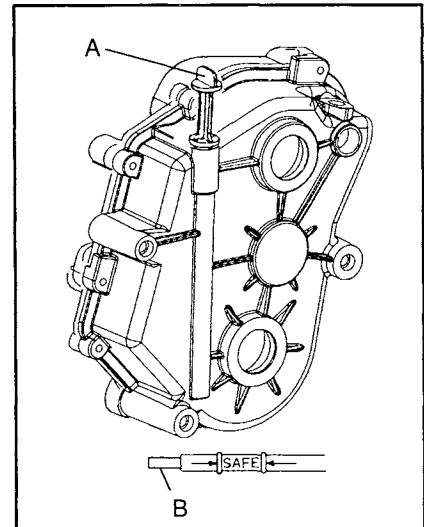

MAINTENANCE/TUNE UP

Suspension Lubrication

Suspension Lubrication

To maintain rider comfort and to retard wear of the pivot shafts, the suspension pivot shafts should be lubricated with Polaris Premium All Season Grease, PN 2871423, at 500 miles (800 km) initially; 1000 miles (1600 km) and before summer storage each year. The riding characteristics of the snowmobile will be affected by lack of lubrication of these shafts. **NOTE:** A grease gun kit complete with grease and adaptors is available to lubricate all fittings on Polaris snowmobiles. Order PN 2871312.

Polaris Premium Grease PN 2871423
Grease Gun Kit PN 2871312

Refer to the following diagrams for suspension lubrication points.

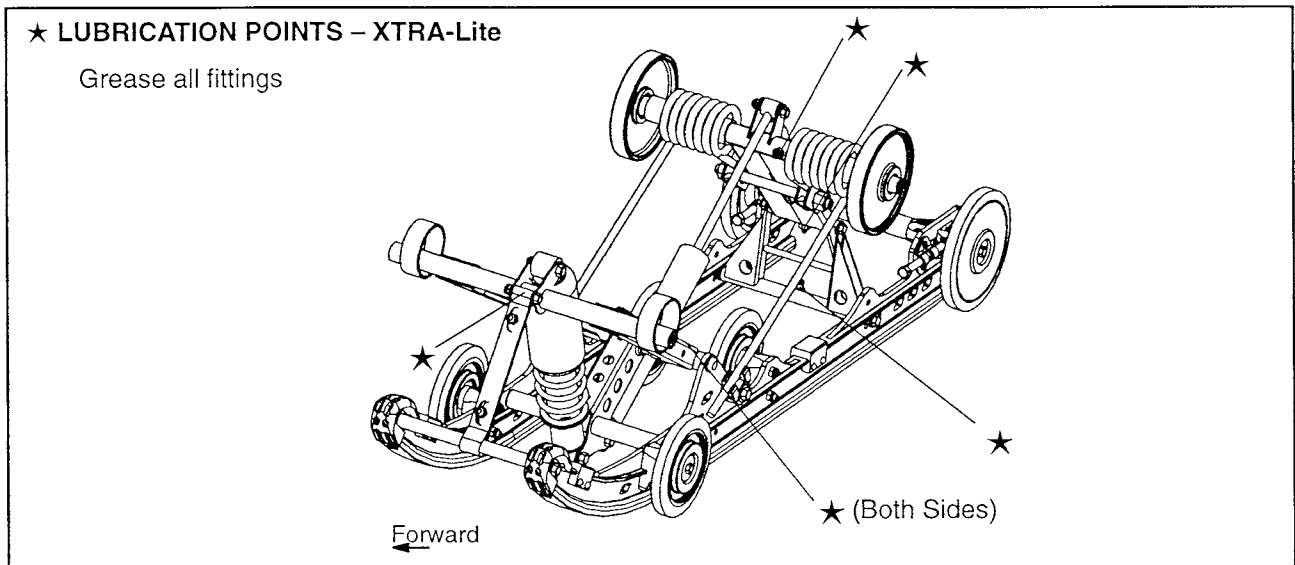
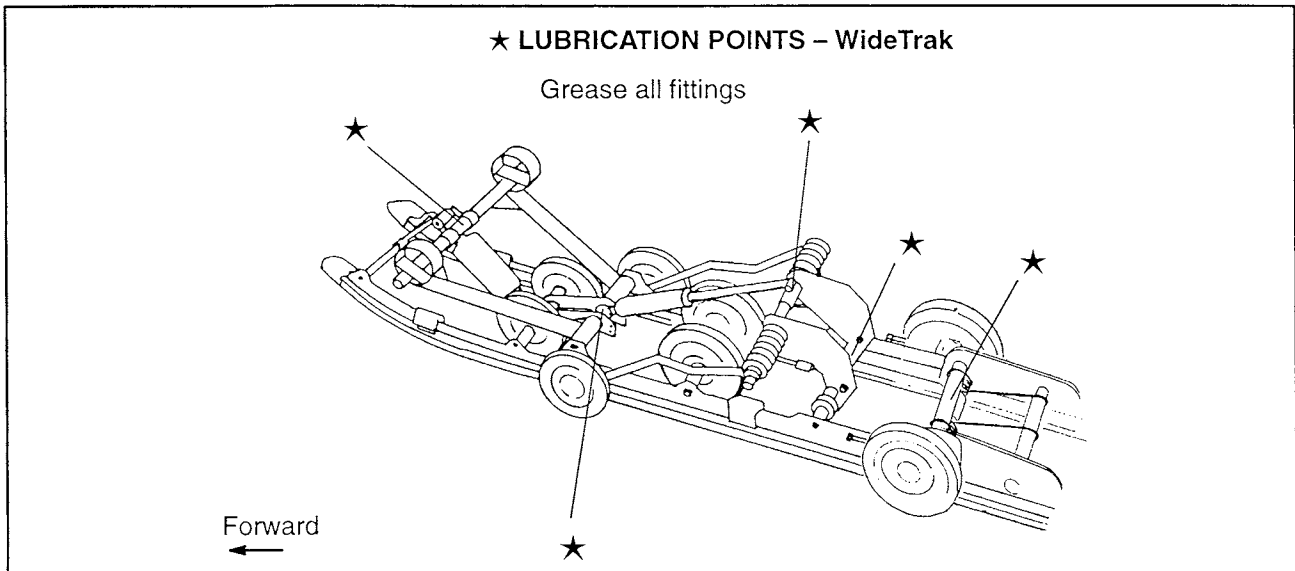

Suspension Lubrication

XTRA 10 Style

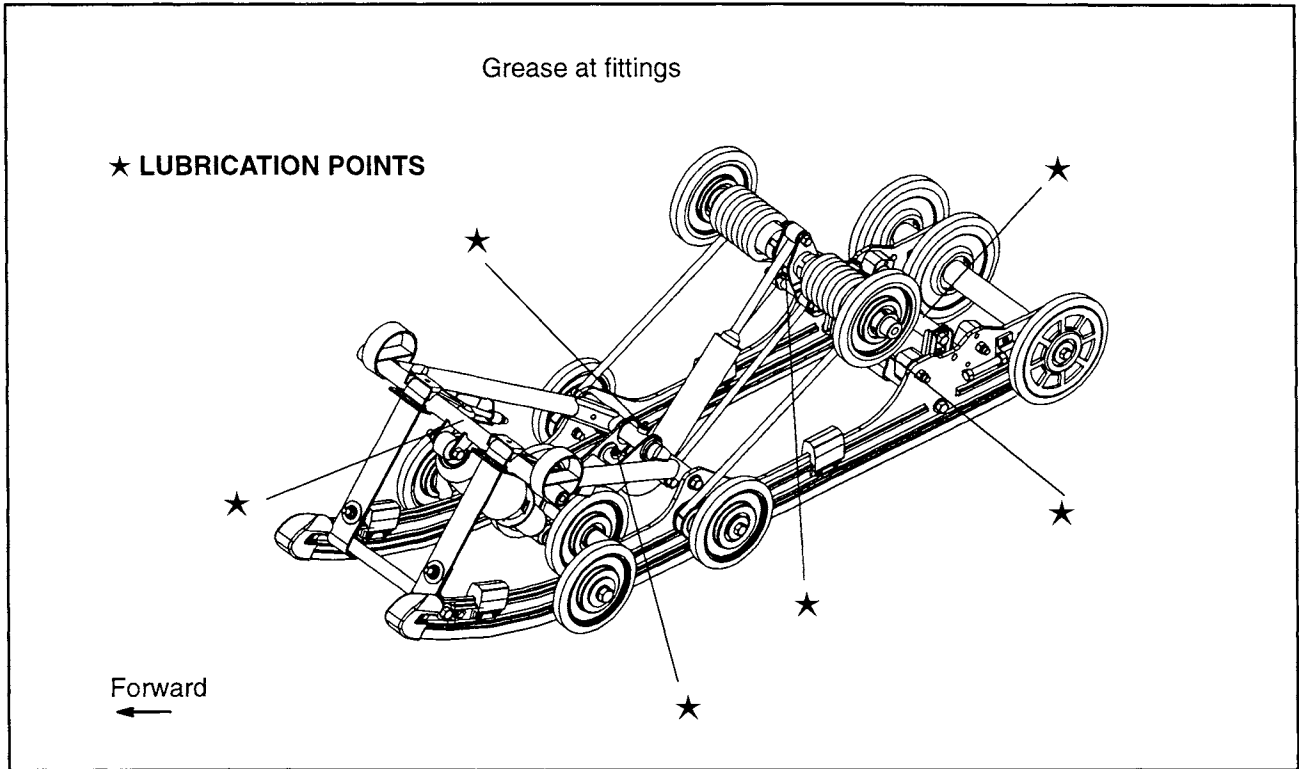

XTRA 12 Style

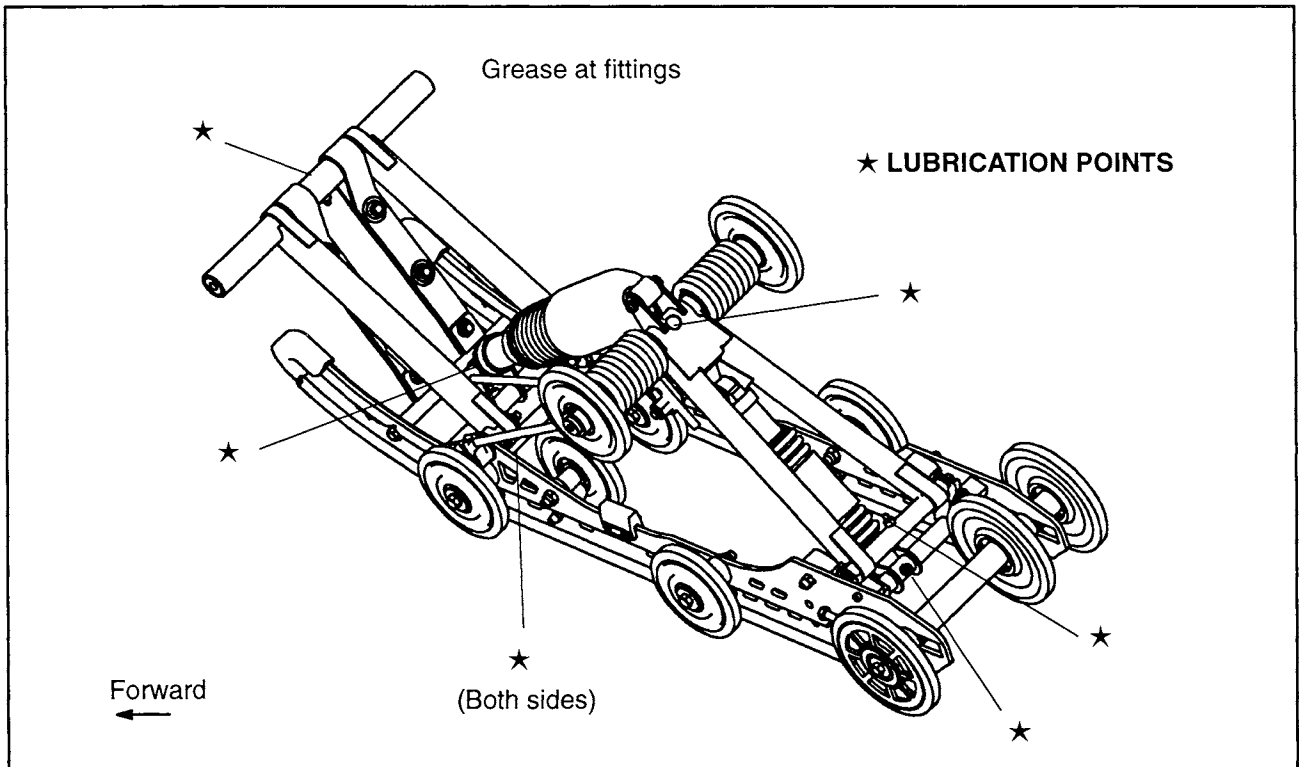

MAINTENANCE/TUNE UP

Cooling System

⚠ WARNING

Never remove the pressure cap when the engine is warm or hot. If the pressure cap is to be removed, the engine must be cool. Severe personal injury could result from steam or hot liquid.

Use of a non-standard pressure cap will not allow the recovery system to function properly. If the cap should need replacement, install the correct Polaris cap with the same pressure rating. Refer to the appropriate parts manual.

Coolant Level

Coolant level in the reservoir or surge tank must be maintained between the minimum and maximum levels to prevent overheating and serious engine damage.

Recommended Coolant

Use a 50/50 or 60/40 mixture of antifreeze and distilled water depending on the freeze protection required for your area. Do not use tap water in the system or reduced cooling or filter contamination may result. Replace coolant every 2 years or if contaminated. Inspect coolant filter annually for contamination and replace if necessary.

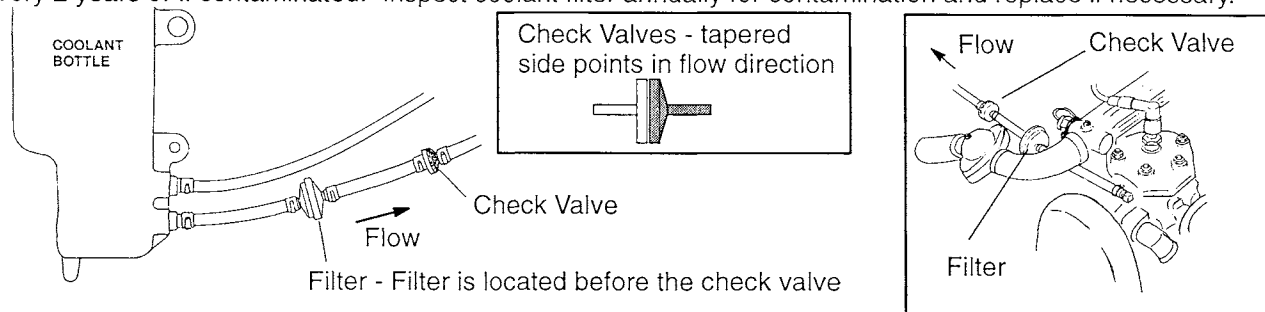

Bleeding the Cooling System - Pressure Caps

If the cooling system should become low in the tank and/or filler neck, the system should be bled of any trapped air using the following procedure:

1. Allow the system to cool completely. Fill the reservoir with coolant to the maximum indicated mark.
2. With pressure cap removed, add coolant and fill to the top of the filler neck.
3. Install the pressure cap with the lever lock up in its release position and run the engine at fast idle for two to three minutes. This will purge the system of trapped air. Close the lever lock and check recovery tank fluid level. **CAUTION:** On models equipped with remote filler neck, *low idle RPM must be used* for bleeding (600 RPM \pm 100) to allow all air to purge and prevent trapped air which can lead to overheating. Reset idle to specified RPM after bleeding.

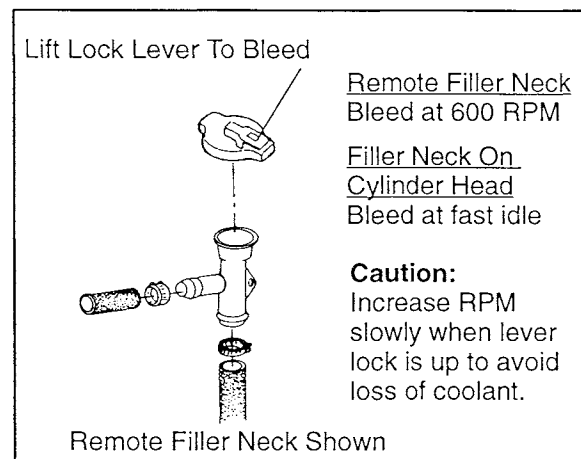

Bleeding the Cooling System - Surge Tanks

If the cooling system should become low in the surge tank, the system must be bled of any trapped air using the following procedure:

1. Allow the system to cool completely. Fill the surge tank with coolant to the maximum indicated mark.
2. Start the engine and loosen the bleed screw on the top of the water pump until trapped air has been purged. Tighten the bleed screw.
3. Loosen the bleed screw at the end and top of the water outlet manifold until trapped air has been purged. Tighten the bleed screw.
4. Recheck the surge tank coolant level and add coolant again if necessary.

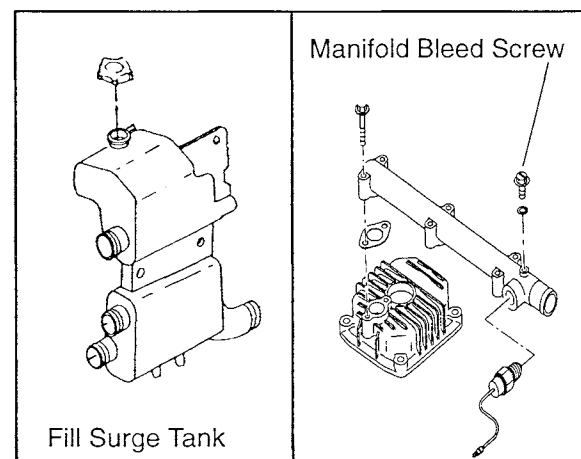

⚠ WARNING

When performing the following checks and adjustments, stay clear of all moving parts to avoid serious personal injury.

Track Maintenance

⚠ WARNING

Never make this maintenance check with the engine running as serious personal injury can result.

Using a hoist, safely lift and support the rear of the snowmobile off the ground. Rotate the track by hand to check for any possible damage.

To inspect track rods, carefully examine the track along the entire length of each rod, bending the track and inspecting for breakage. The three most common places where breakage occurs are shown in the illustration.

If any rod damage is found, the track should be replaced.

⚠ WARNING

Broken track rods are a serious hazard, since they can cause a rotating track to come off the machine. Never operate or rotate a torn or damaged track under power. Serious personal injury or death may occur.

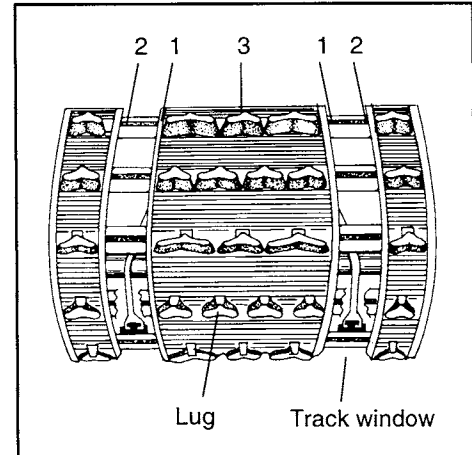

Track Alignment

Track alignment affects track tension. Misalignment will cause excessive wear to the track and slide rail.

A periodic check should be made to see that the track is centered and running evenly on the slide rails. Misalignment will cause excessive wear to the track and slide rail. **NOTE:** If excessive hi-fax wear occurs due to poor snow conditions, additional wheel kits are available.

1. Safely support the rear of the machine with the track off the ground.
2. Start the engine and apply a small amount of throttle until the track turns *slowly* at least five complete revolutions. Stop the engine.
3. Inspect track alignment by looking through the track window to make sure the rails are evenly spaced on each side. If the track runs to the left, loosen left locknut and tighten the left adjusting bolt. If the track runs to the right, loosen right locknut and tighten the right adjusting bolt.
4. After adjustments are complete, be sure to tighten locknuts and idler shaft bolts. Torque to specification.

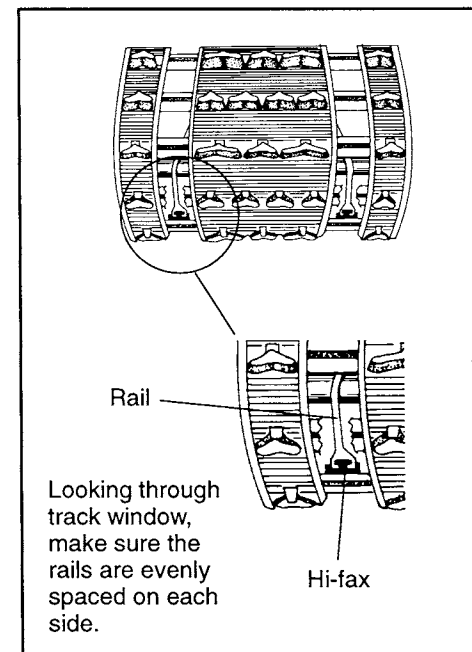

Idler Shaft Bolt Torque -
35 - 40 ft. lbs. (4.8 - 5.5 kgm)

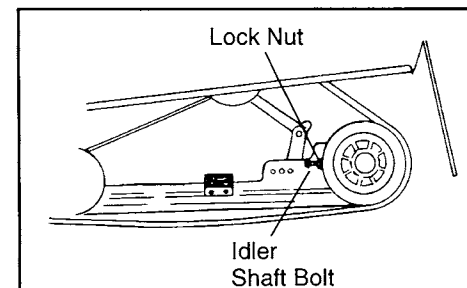

MAINTENANCE/TUNE UP

Track Maintenance/Adjustment

Track Tension Data

Suspension	Weight	Measurement Location	Measurement
XTRA 12 121"	none	2" behind rail bumper	1/2" (1.3 cm) free hanging
XTRA 12 133"	none	16" ahead of rear idler shaft	1-1 1/8" (2.5 - 2.9 cm) free hanging
XTRA 10 121", 133", 136"	10 lbs. (4.54 kg)	16" ahead of rear idler shaft	3/8 - 1/2" (1 - 1.3 cm)
WideTrak	10 lbs. (4.54 kg)	16" ahead of rear idler shaft	3/4 - 1" (1.9 - 2.5 cm)
XTRA Lite 121" and 133"	10 lbs. (4.54 kg)	16" ahead of rear idler shaft	3/8 - 1/2" (1 - 1.3 cm)
XTRA Lite 136"	10 lbs. (4.54 kg)	16" ahead of rear idler shaft	3/8 - 1" (1 - 2.5 cm)

⚠ WARNING

When performing the following checks and adjustments, stay clear of all moving parts to avoid serious personal injury.

Track Tension - XTRA Lite Style

1. Turn the machine off.
2. Lift the rear of the machine and safely support it off the ground.
3. Place a 10 lb. (4.5 kg) weight on the track at a point approximately 16" (40.6 cm) ahead of the center of the rear idler wheel.
4. Check for proper slack between the inside of the track clip wear surface and the hi-fax (C). **NOTE:** Measure at the point where the weight is hanging.

**XTRA Lite 121" and 133" -
3/8 - 1/2" slack (1 - 1.3 cm) w/10
lb. (4.54 kg) weight
XTRA Lite 136" - 3/8-1"(1-2.5 cm)
w/10 lb. (4.54 kg) weight**

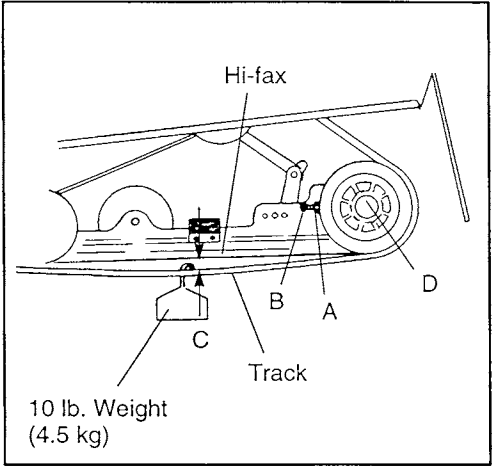

If the track needs adjustment:

5. Loosen rear idler shaft bolts (D) on both sides of the machine.
6. Loosen track adjusting bolt locknuts (A).
7. Tighten or loosen the track adjusting bolts (B) evenly as necessary to obtain proper track tension.
8. Tighten idler shaft bolts and adjuster bolt locknuts.

NOTE: Track alignment affects track tension. Misalignment will cause excessive wear to the track and slide rail. Excessive Hi Fax wear will appear on units with track tension set too tight.

⚠ WARNING

When performing the following checks and adjustments, stay clear of all moving parts to avoid serious personal injury.

Track Tension - WideTrak LX

Tension adjustments should be made only after the track is warmed up and limber.

1. Turn the machine off.
2. Lift the rear of the machine and safely support it off the ground.
3. Place a 10 lb. (4.5 kg) weight on the track at a point approximately 16" (40.6 cm) ahead of the center of the rear idler wheel.
4. Check for 3/4-1" (1.9-2.5 cm) slack between the inside of the track clip and the plastic hi-fax (C).

NOTE: Measure at the point where the weight is hanging.

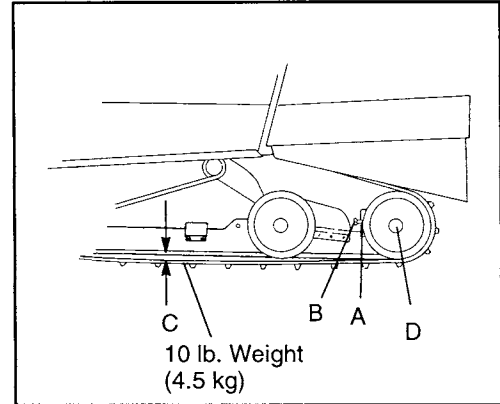

**WideTrak LX Track Tension -
3/4 - 1" slack (1.9 - 2.5 cm)
w/10 lb. (4.54 kg) weight**

If the track needs adjustment:

5. Loosen rear idler shaft bolt (D).
6. Loosen locknuts (A).
7. Tighten or loosen the track adjusting screws (B) as necessary to provide equal adjustment on both sides of the track.

NOTE: Track alignment affects track tension. Misalignment will cause excessive wear to the track and slide rail. Excessive Hi Fax wear will appear on units with track tension set too tight.

MAINTENANCE/TUNE UP

Track Maintenance/Adjustment

⚠ WARNING

When performing the following checks and adjustments, stay clear of all moving parts to avoid serious personal injury.

Track Tension - XTRA 10 Style

1. Turn the machine off.
2. Lift the rear of the machine and safely support it off the ground.
3. Place a 10 lb. (4.5 kg) weight on the track at a point approximately 16" (40.6 cm) ahead of the center of the rear idler wheel (D).
4. Check for 3/8-1/2" (1-1.3 cm) slack between the inside of the track clip and the hi-fax (C). **NOTE:** Measure at the point where the weight is hanging.

**XTRA 10 121", 133", & 136" Style Track
Tension - 3/8 - 1/2" slack (1 - 1.3 cm)
w/10 lb. (4.54 kg) weight**

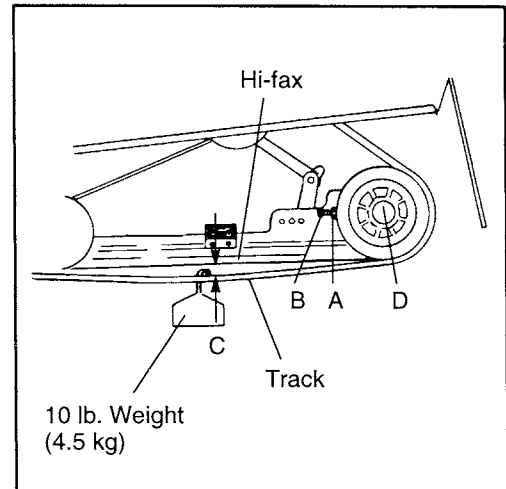

If the track needs adjustment:

5. Loosen rear idler shaft bolts (D) on both sides of the machine.
6. Loosen track adjusting bolt locknuts (A).
7. Tighten or loosen the track adjusting bolts (B) evenly as necessary to obtain proper track tension.
8. Tighten idler shaft bolts and adjuster bolt locknuts.

Always inspect track alignment after track tension adjustment.

NOTE: Track alignment affects track tension. Misalignment will cause excessive wear to the track and slide rail. Excessive Hi Fax wear will appear on units with track tension set too tight.

MAINTENANCE/TUNE UP Track Maintenance/Adjustment

⚠ WARNING

When performing the following checks and adjustments, stay clear of all moving parts to avoid serious personal injury.

Track Tension - XTRA 12 Style

1. Turn the machine off.
2. Lift the rear of the machine and safely support it off the ground.
3. Take measurement with track free hanging at a point 2" behind rail bumper or 16" ahead of rear idler on 133" tracks. The distance between the inside top of the track clip and the Hi-Fax should be as shown below and in the illustration at right. Repeat measurement on the other side of the track. **NOTE:** Check more frequently when machine is new.

XTRA 12 Style Track Tension -
121" 1/2" (1.3 cm) free hanging
133" 1 - 1 1/8" (2.54 - 2.86 cm) free
hanging

If the track needs adjustment:

4. Loosen rear idler shaft bolts on both sides of the machine.
5. Loosen track adjusting bolt locknuts.
6. Tighten or loosen the track adjusting bolts evenly as necessary to obtain proper track tension.
7. Tighten idler shaft bolts and adjuster bolt locknuts.

Always inspect track alignment after track tension adjustment.

NOTE: Track alignment affects track tension. Misalignment will cause excessive wear to the track and slide rail. Excessive Hi Fax wear will appear on units with track tension set too tight.

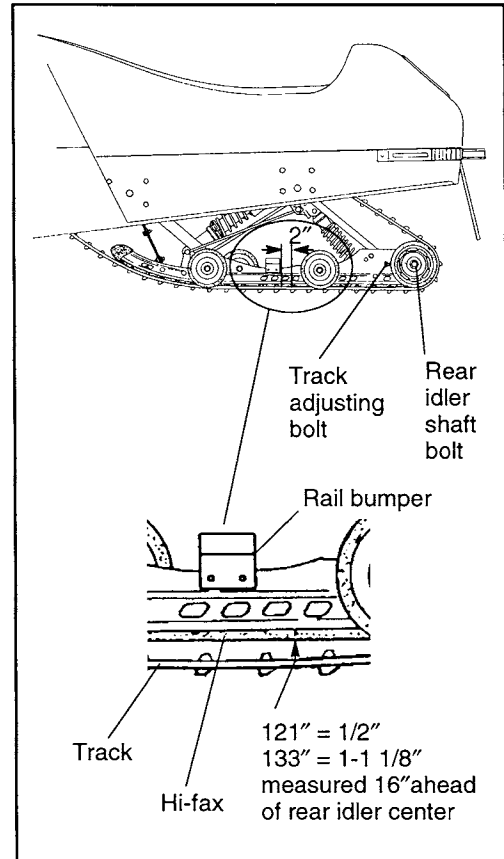

MAINTENANCE/TUNE UP

Spark Plugs

Spark Plug Selection

Original equipment parts or their equivalent should always be used. However, the heat range of spark plugs is of utmost importance. A spark plug with a heat range which is too high will cause engine damage. A spark plug with a heat range which is too low will cause excessive fouling and malfunction.

In selecting a spark plug heat range for production, a manufacturer is forced to assume that the engine is going to be operated under extreme heavy duty conditions. This protects the engine from internal damage in the event that the purchaser actually does operate the engine in this manner. This selection however, could cause the customer who normally operates the engine under medium or light duty to have spark plug failure.

CAUTION:

A plug with a heat range which is too high will *a/ways* cause engine damage if the engine is operated in conditions more severe than that for which the spark plug was intended.

A new engine can cause temporary spark plug fouling even though the heat range is correct, due to the preservative which has been added during assembly of the engine to combat rust and corrosion. Avoid prolonged idle speeds, as plug fouling and carbonization will result. Always use resistor type spark plugs.

NOTE: Incorrect fuel mixture can often cause a spark plug to appear to be too dark or too light in color. Before changing spark plug heat ranges, be sure the correct main jet is installed in the carburetor(s).

The spark plug and its condition is indicative of engine operation. The spark plug firing end condition should be read after the engine is warmed up and the vehicle is driven at higher speeds. Immediately check the spark plug for correct color.

Normal

The insulator tip is gray, tan, or light brown. There will be a few combustion deposits. The electrodes are not burned or eroded. This indicates the proper type and heat range for the engine and the service.

NOTE: The tip should not be white. A white insulator tip indicates overheating, caused by use of an improper spark plug or incorrect carburetion adjustments.

Wet Fouled

The insulator tip is black. A damp oily film covers the firing end. There may be a carbon layer over the entire nose. Generally, the electrodes are not worn. General causes are excessive oil, use of non-recommended injection oil, excessive idling, idle too low or too rich, or weak ignition output.

1. Inspect electrodes for wear and carbon buildup. Look for a sharp outer edge with no rounding or erosion of the electrodes.
2. Clean with electrical contact cleaner or a glass bead spark plug cleaner only.

CAUTION:

A wire brush or coated abrasive should not be used.

3. Measure gap with a wire gauge and adjust to specifications by bending side electrode carefully.
4. Coat spark plug threads with a small amount of anti-seize compound.
5. Install spark plug and torque to specification.

Spark Plug Torque:

11 Ft. Lbs (1.52 kg-m)

Drive Belt

⚠ WARNING

Inspect the condition of the drive belt. Inspect clutch sheaves for damage, wear, or belt residue. Clean with non-oil base cleaner such as isopropyl alcohol.

To ensure satisfactory belt life, install belts so they operate in the same direction of rotation. Position the identification numbers so that you can read them. This will keep the belt rotating in the same direction.

Belt Removal

1. Be sure key switch is off and engine has come to a complete stop. Remove the retaining knob or pin and open the clutch guard.
2. Apply brake (or lock parking brake if so equipped).
3. Grasp belt firmly midway between clutches and pull upward and rearward to open the driven clutch sheaves. Remove the belt from the driven clutch and then from the drive clutch.

Belt Installation

1. Drop the drive belt over the drive clutch and pull back the slack.
2. Turn the driven clutch moveable sheave clockwise while at the same time pushing inward and forcing the belt down between the sheaves.
3. Hold the belt down between the sheaves and roll the bottom portion over the outer clutch sheave. Once installed, be sure to work the belt to the outer edge of the sheave. Be sure to release parking brake if applied.
4. Close the clutch guard and reinstall the retaining knob or pin.

Belt Inspection

5. Refer to PVT Section for belt inspection and width measurement.
6. Measure belt length with a tape measure around the outer circumference of the belt. Belts which measure shorter or longer than a nominal length may require driven clutch or engine adjustment to obtain proper belt deflection.
7. Replace belt if worn past the service limit. Belts with thin spots, burn marks, etc., should be replaced to eliminate noise, vibration, or erratic operation. See Troubleshooting Chart at the back of this chapter for possible causes. **NOTE:** If a new belt is installed, check belt deflection. Install so part numbers are easily read.

Refer to the specification charts for belt specifications and measurement procedures.

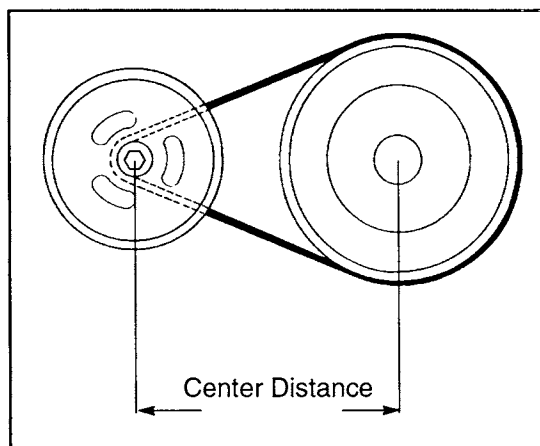
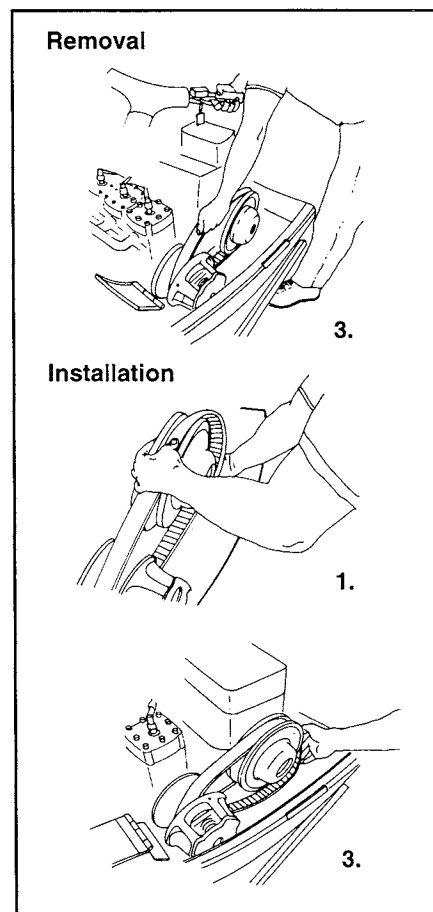

MAINTENANCE/TUNE UP Backrest Adjustment

Backrest Adjustment

The passenger backrest on the Classic Touring and XLT Touring Models is adjustable. To move the backrest forward or backward, lift the adjustment lever on the left side.

To lengthen or shorten the backrest cable, lift the cable until spring tension is felt and lock the jamb nut.

When adjusting the backrest from a passenger position to a single rider position, rotate the backrest cushion adjustment knobs until the proper angle is reached.

The grab bars have five height adjustments. To raise or lower the grab bar, remove the grab bar adjuster knob, position the grab bar at the desired height, and reinstall the knob.

The Classic Touring and XLT Touring models are also equipped with passenger handwarmers. The handwarmer switch, located under the left hand wind deflector, has three settings: high, off, and low.

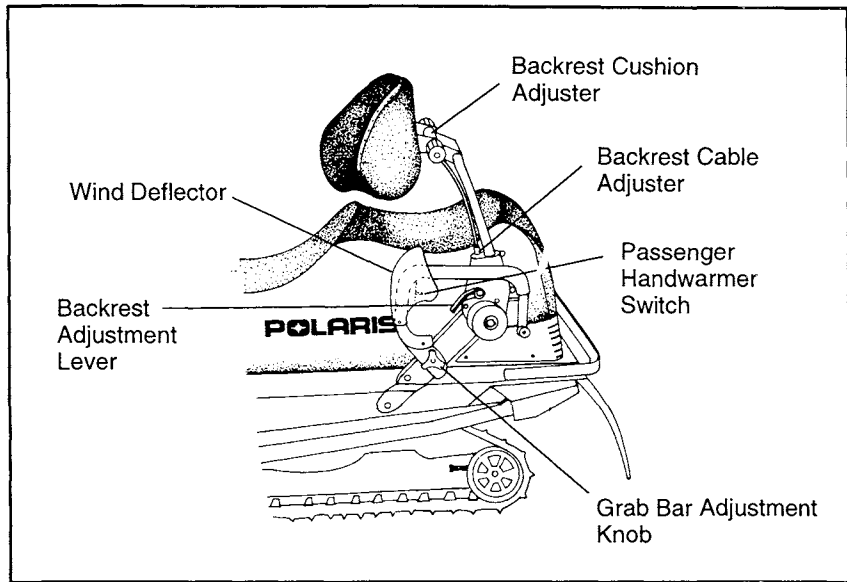

MAINTENANCE/TUNE UP

Headlight Adjustment - Gen II, Indy 340, and Evolved Style Models

Headlight Adjustment

The headlight can be adjusted for vertical aim using the following procedure:

1. Place the snowmobile on a level surface with the headlight approximately 25' (7.6 m) from a wall.
2. Measure the distance from the floor to the center of the headlight and make a mark on the wall.
3. Start the engine and turn the headlight switch to high beam.
4. Observe the headlight aim. The most intense part of the headlight beam should be aimed 2" (5.1 cm) below the mark placed on the wall in Step 2. **NOTE:** Rider weight must be included on the seat.
5. If necessary, the headlight aim can be adjusted by turning the adjustment knob located inside the hood just below the headlamp opening. Turn knob in or out as needed for proper aim.

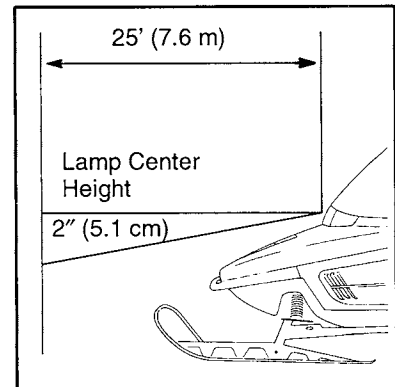

Removing the Center Bulb

1. Push down on spring until it releases from spring retainer.
2. With wire harness attached to bulb, withdraw bulb from housing.
3. Grasp bulb by metal base and carefully separate bulb from harness.

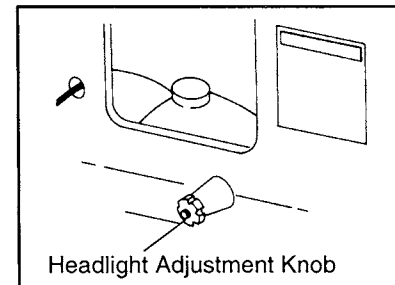

Installing the Center Bulb

NOTE: Do not touch a halogen bulb with bare fingers. Oil from skin leaves a residue, causing a hot spot which will shorten the life of the lamp.

1. Hold bulb by metal base *only* and install into wire harness.
2. Insert bulb into housing.
3. Push spring down until it is secured by spring retainer.
4. Verify headlight aim.

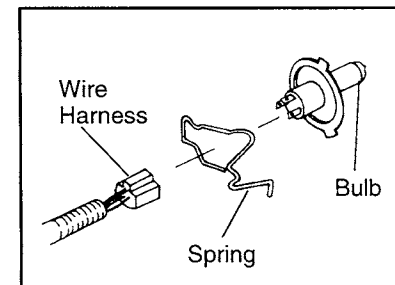

Removing the Side Bulbs

1. Disconnect terminal from back of bulb.
2. Turn bulb assembly 1/4 turn to right and withdraw from housing.

Installing the Side Bulbs

NOTE: Do not touch a halogen bulb with bare fingers. Oil from skin leaves a residue, causing a hot spot which will shorten the life of the lamp.

1. Hold bulb assembly by plastic base and plug into wire terminal.
2. Insert bulb assembly into housing.
3. Turn bulb assembly 1/4 turn to left to secure in housing.
4. Verify headlight operation.

MAINTENANCE/TUNE UP

Headlight Adjustment - Aggressive Style Models

Headlight Adjustment

The headlight can be adjusted for vertical aim using the following procedure:

1. Place snowmobile on a level surface with headlight approximately 25' (7.6m) from a wall.
2. Measure distance from floor to center of headlight and make a mark on the wall.
3. Start engine and turn headlight switch to high beam.
4. Observe headlight aim. The most intense part of the headlight beam should be aimed 2" (5.1 cm) below the mark placed on the wall in Step 2. **NOTE:** Rider weight must be included on the seat.
5. If necessary, headlight aim can be adjusted by inserting a Phillips screwdriver into the boss in the top of the console and turning the screw until correct adjustment is achieved.

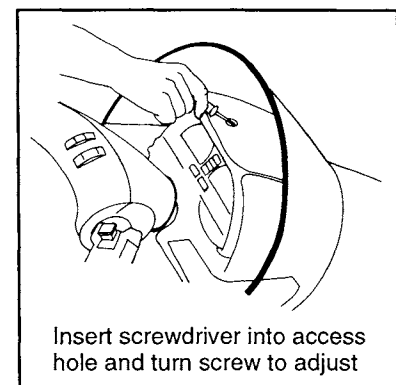
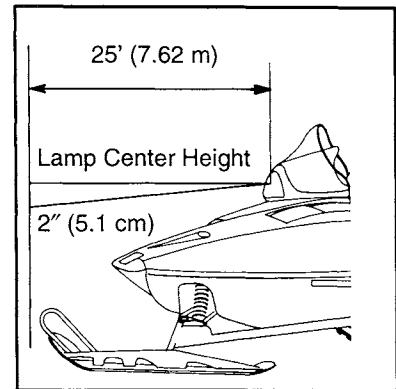

Removing the Bulb

1. Push down on left side of spring until it releases from spring retainer.
2. Lift spring carefully around wire harness and flip to outside of housing.
3. With the wire harness attached to the bulb, withdraw bulb from housing.
4. Grasp bulb by metal base and carefully separate bulb from harness.

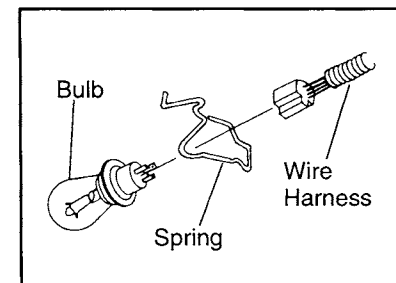

Installing the Bulb

1. Hold bulb by metal base and install into wire harness.
2. Insert bulb into housing.
3. Carefully flip spring back into housing placing it around wire harness.
4. Push spring down until it is secured by spring retainer.
5. Verify headlight aim.

Taillight Bulb Replacement

1. Remove (5) Phillips screws from taillight lens.
2. Working from front to back, carefully pry lens away from seal and remove lens.
3. Pull bulb straight out from socket and insert new bulb.
4. Reinstall lens.

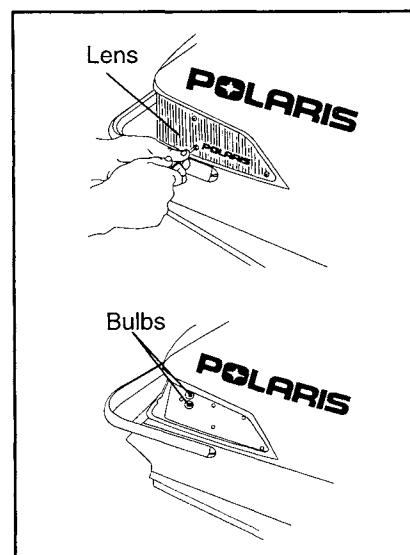

MAINTENANCE/TUNE UP Handlebar Adjustment

Handlebar Adjustment - Evolved and Aggressive Style Models

1. Remove two plastic fasteners holding console cover located below handlebar cover on hood side of steering post.
2. Using a 7/16" (11 mm) wrench, loosen four nuts on bottom of adjuster block. **NOTE:** Turn handlebar to left or right for access to rear nuts.
3. Adjust handlebar to the desired height. Be sure that handlebars, brake lever and throttle lever operate smoothly and do not hit the gas tank, windshield or any other part of the machine when turned fully to the left or right.
4. Torque the handlebar adjuster block bolts to specification. Maintain an equal gap on front and back of block.
5. Replace console cover.

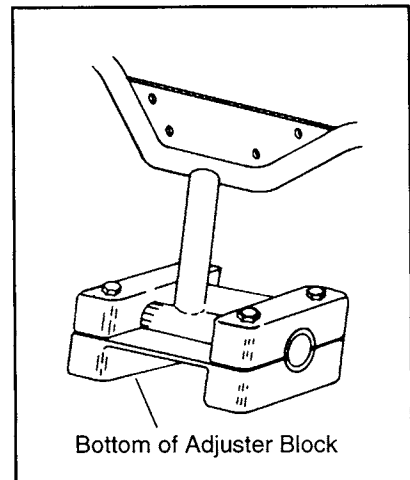

Handlebar Adjustment - All Other Models

1. Remove handlebar cover.
2. Using a 7/16" (11 mm) wrench, loosen four nuts on bottom of adjuster block. **NOTE:** Turn handlebar to left or right for access to back nuts.
3. Adjust handlebar to the desired height. Be sure that handlebars, brake lever and throttle lever operate smoothly and do not hit the gas tank, windshield or any other part of the machine when turned fully to the left or right.
4. Torque the handlebar adjuster block bolts to specification. Maintain an equal gap on front and back of block.
5. Replace handlebar cover.

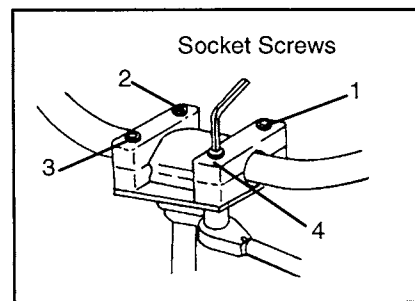

Handlebar Adjuster Block Bolt Torque -

11 - 13 ft. lbs. (1.5 - 1.8 kgm)

⚠ WARNING

Improper adjustment of the handlebars, or incorrect torquing of the adjuster block tightening bolts can cause limited steering or loosening of the handlebars, resulting in loss of control.

MAINTENANCE/TUNE UP

Brakes

Replenishing Brake Fluid

Remove brake fluid master cylinder reservoir cover. Add Polaris brake fluid as required to bring the level up to the top of the fluid level mark on the inside of the reservoir (B). The proper fluid level is 1/4-5/16" (.6-.8 cm) below the lip of the reservoir opening.

NOTE: On some models, the brake fluid level can be seen through the plastic reservoir. The fluid should be maintained between the minimum and maximum marks on the reservoir for those models.

Inspect the reservoir to be sure it contains the correct amount of fluid. Use only Polaris DOT 3 high temperature brake fluid. Change fluid every 2 years or whenever the fluid is dark or contamination is suspected.

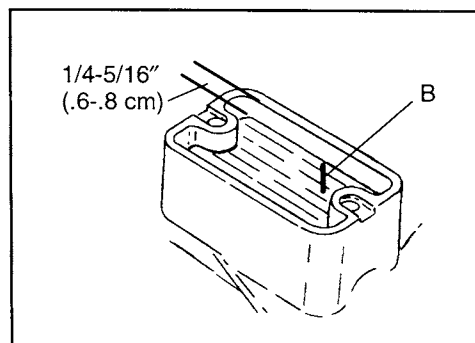

Master Cylinder Fluid Level

1/4 - 5/16" (.6 - .8 cm) below lip of reservoir opening

Polaris DOT 3 High Temp Brake Fluid

PN 2870990

⚠ WARNING

Do not over fill the master cylinder. Fluid expansion could cause brakes to lock, resulting in serious injury or death. Once a bottle of brake fluid is opened, use what is necessary and discard the rest. Do not store or use a partial bottle of brake fluid. Brake fluid is hygroscopic, meaning it rapidly absorbs moisture from the air. This causes the boiling temperature of the brake fluid to drop, leading to early brake fade and the possibility of serious injury.

Bleeding the Hydraulic Brake System

Air in the hydraulic brake system will cause a springy or spongy brake lever action. Bleeding is necessary to remove air from the system.

1. Remove brake fluid master cylinder reservoir cover and gasket.

CAUTION: Brake fluid is a hazardous material. Contact with decals, paint, and many plastics will cause damage. Use proper precautions when handling brake fluid.

2. Fill the master cylinder reservoir (B) and replace gasket and cover. Keep the fluid level 1/4-5/16" (.6-.8 cm) below lip of reservoir opening.
3. Slip a rubber tube over the ball of the bleeder valve and direct the flow of fluid into a container.

⚠ WARNING

Never re-use brake fluid. Brake fluid is hygroscopic, meaning it rapidly absorbs moisture from the air. This causes the boiling temperature of the brake fluid to drop, leading to early brake fade and the possibility of serious injury.

4. Squeeze brake lever a full stroke. Then unscrew bleeder valve (A) 3/4 of a turn to release air.
5. Close bleeder valve first and then release brake lever.

Repeat steps 4 and 5 until fluid flows from bleeder valve in a solid stream free of air bubbles. Do not allow reservoir to run dry or air will be drawn into system.

6. Re-fill reservoir to proper level after bleeding operation. *Do not overfill the master cylinder.*
7. Replace gasket and cover.

During the bleeding procedure make sure to keep the reservoir as level as possible to minimize the possibility of air entering the system.

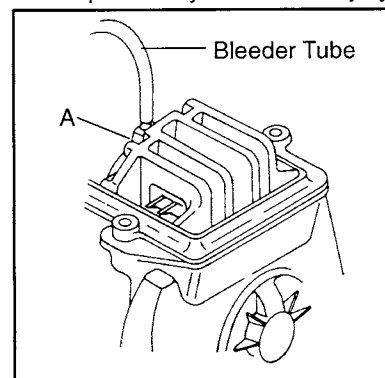

Brake Adjustment - Mechanical Disc Brakes

If excessive brake lever to brake block clearance is evident, the caliper adjuster should be adjusted using the following method.

⚠ WARNING

Adjust brake with caliper adjuster bolt only. *Do not* adjust cable or cable sleeve length. Improper brake adjustment could result in brake failure which could result in severe injury or death.

Caliper Adjustment

1. Bend locking tab (A) away from lock nut (B) and loosen lock nut.
2. Push down on actuating lever (C) and insert a .015" feeler gauge between the brake disc and outer brake pad.
3. Turn adjusting bolt (D) in until a slight pressure is felt against the feeler gauge.
4. While holding adjusting bolt (D), tighten locknut (B).
5. Bend locking tab (A) against locknut.

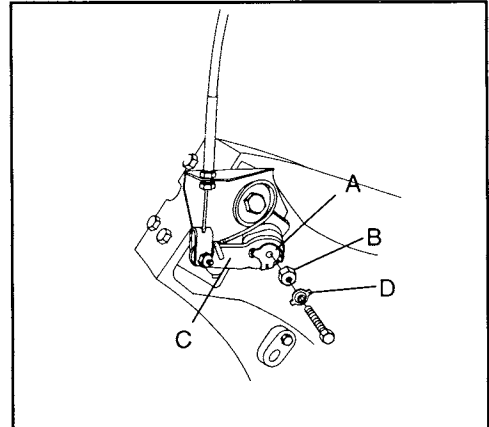

⚠ WARNING

Be certain locking tab is correctly positioned in actuating lever. After locknut is tightened, check pad to disc clearance to be certain there is .015" clearance.

Be certain brake pads are not dragging on disc and brake lever travel is not excessive.

Improper brake adjustment could result in brake failure which could result in severe injury or death.

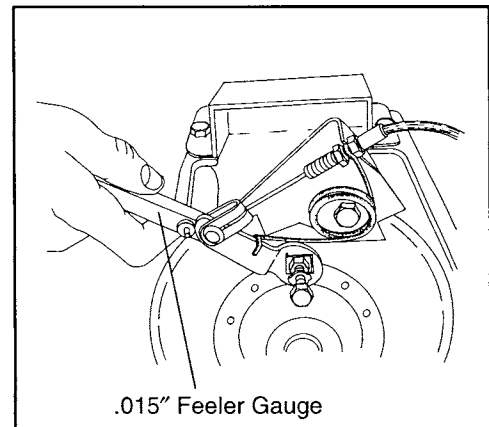

Brake Pad to Disc Clearance -
.015" (.38 mm)

NOTE: Replace pads when worn beyond service limit.

Brake Pad Thickness - Type M3 shown.
Service Limit .250" (6.35mm)
(All brake pads)

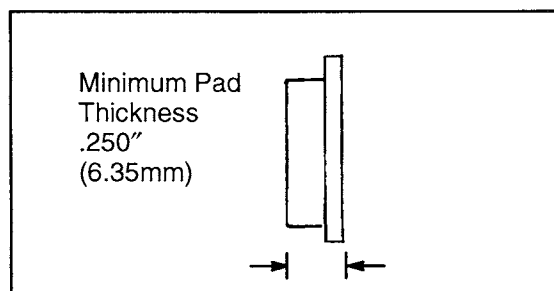

MAINTENANCE/TUNE UP

Brakes

WT-2 Brake Adjustment

1. Check to ensure floating parts move freely and that all other parts are mounted securely. Tighten hardware as required.
2. Check actuator linkage to ensure there is adequate freedom of movement for positive brake operation. Periodic adjustment of pad gap can be performed using actuating cable.
3. Loosen lock nuts.
4. To increase brake lever free play turn nuts counterclockwise to move cable down in bracket. To decrease lever free play move cable up in bracket. Tighten lock nuts.

Brake Lever Free Play

1/4-3/8 in. (6-10mm)

5. If cable adjuster has reached maximum (used up), the lever arm can be re-indexed. Loosen lock nuts and turn counterclockwise (as viewed from top) to obtain the maximum amount of cable freeplay. Straighten tab on tab washer and loosen bolt enough to disengage actuator lever spline.
6. Slip long leg of lever spring off caliper and rotate to the side.
7. Rotate the lever one tooth in the direction opposite the actuation direction, and tighten bolt making sure spline teeth are properly engaged.
8. Bend up a tab aligning with one of the bolt head flats to prevent bolt rotation.
9. Return the spring to its original position on the caliper. Both lever and linkage must be free to return to original position.
10. Perform steps 3. and 4. to adjust lever freeplay.
11. Verify proper brake operation. Disc should rotate freely without drag.
12. Check disc surface condition. Refer to Brake/Final Drive section to inspect disc and pad condition and thickness.

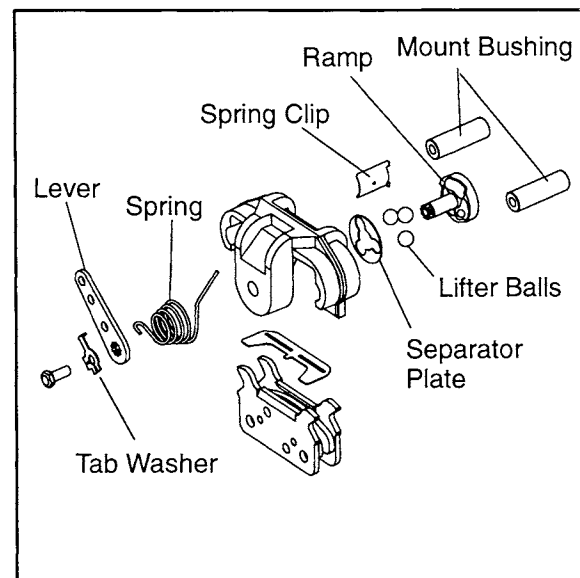
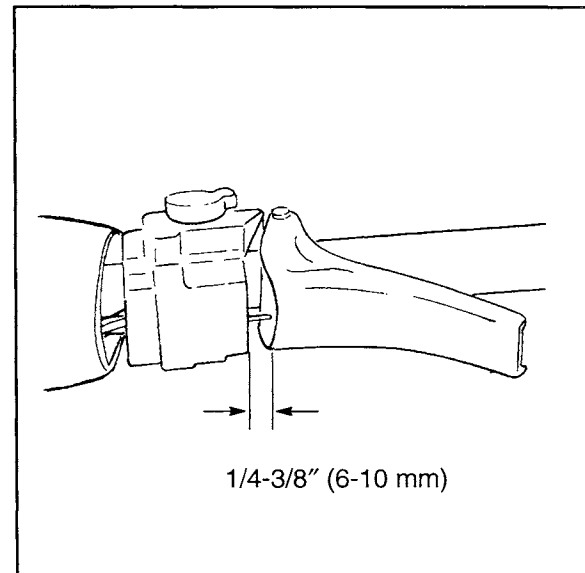
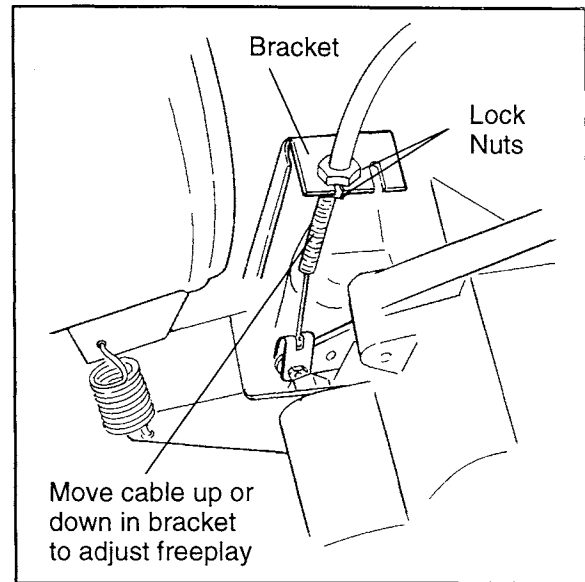

MAINTENANCE/TUNE UP Reverse Kit Maintenance

Adjustment

Due to break-in or replacement of components, the reverse shift mechanism may require adjustment.

Gen II Style

1. Loosen jam nuts on linkage rod (A).
2. Turn the threaded linkage rod (B) to lengthen or shorten the throw until reverse engages fully.
3. Tighten jam nuts and re-check adjustment.

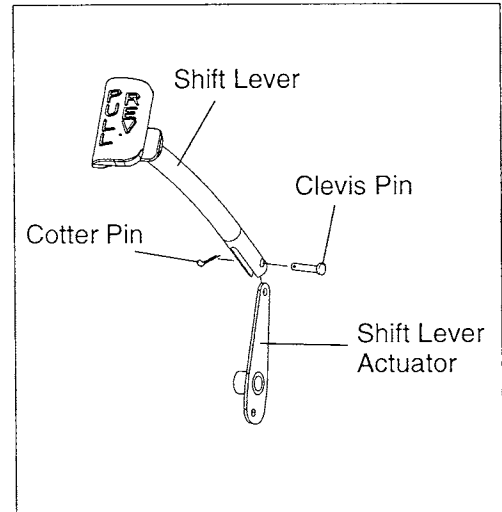

Evolved and Aggressive Style

1. Lift shift lever slowly while observing shift arm on transmission.
2. If adjustment is correct, shift will move 1 - 1 1/2" before the shift arm begins to move. If adjustment is required, proceed with step 3.
3. Loosen jam nuts on lower end of cable.
4. Adjust cable end at transmission until the end of the shift lever has 1 - 1 1/2" (2.5 - 3.8 cm) of freeplay before the cable starts to move the shift arm. Do not adjust beyond this point.
5. Tighten jam nuts and re-check adjustment.

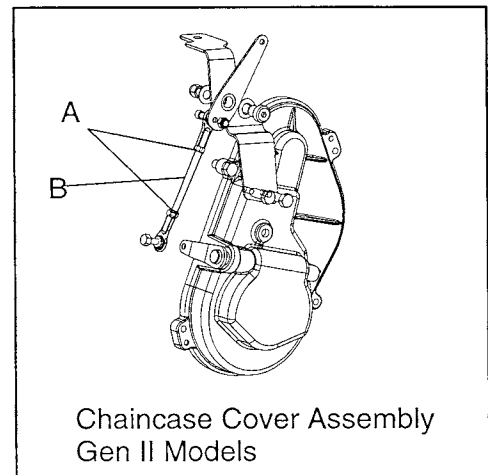

Reverse Cable End Play -

1/32" (.08 cm)

Reverse Shift Lever Freeplay -

1 - 1 1/2" (2.5 - 3.8 cm) measured at end of shift lever

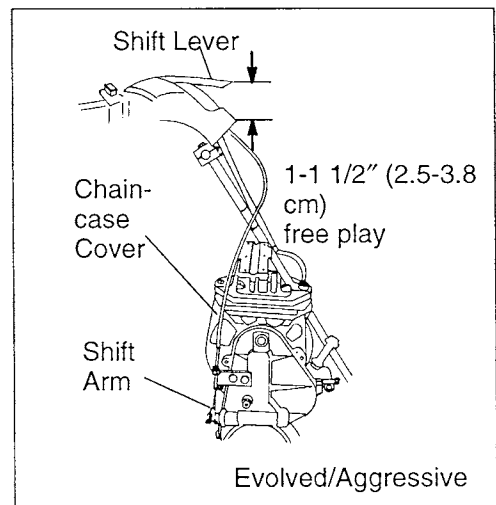

MAINTENANCE/TUNE UP

Reverse Kit Maintenance

Adjustment

Due to break-in or replacement of components, the reverse shift mechanism may require adjustment. Adjust with the shifter in the forward position.

Indy 340 Style

1. Loosen jam nuts on lower end of cable.
2. Adjust cable until endplay movement of cable housing at the handlebar bracket is $1/32''$ (.08 cm). Do not adjust beyond this point.
3. Tighten jam nuts and re-check adjustment.

Reverse Cable End Play -

$1/32''$ (.08 cm)

Reverse Shift Lever Freeplay -

1 - 1 1/2'' (2.5 - 3.8 cm) measured at end of shift lever

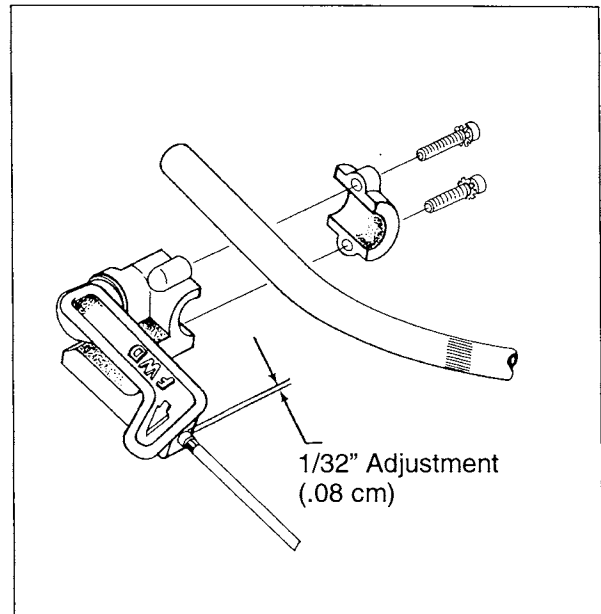

Cleaning And Preservation Of Hood, Chassis And Trim

Proper storage starts by cleaning, washing and waxing the hood, chassis, upholstery and plastic parts. Clean and touch up with paint any rusted or bare metal surfaces. Ensure that all corrosive salt and acids are removed from surfaces before beginning preservation with waxes and rust inhibitors (grease, oil, or paint).

If the machine is equipped with a battery, disconnect the battery cables and clean the cables and battery posts. Fill battery to proper level with distilled water and charge to full capacity. Remove and store the battery in a cool dry place.

The machine should be stored in a dry garage or shed out of the sunlight and covered with a fabric snowmobile cover. *Do not use plastic to cover the machine;* moisture will be trapped inside causing rust and corrosion problems.

Controls And Linkage

All bushings, spindle shafts and tie rod ends should be coated with a light coat of oil or grease. Throttle controls and cables should be lubricated with Polaris Cable Lubricant. Force a small amount of lubricant down cables.

Polaris Cable Lubricant

PN 2870510

Electrical Connections

Separate electrical connector blocks and clean corrosive build-up from connectors. Lubricate or pack connector blocks with dielectric grease and reconnect. Replace worn or frayed electrical wire and connectors.

Dielectric Grease PN 2871027

Clutch And Drive System

Remove drive belt and store in a cool dry location. Lubricate sheave faces, shaft and ramps of drive and driven clutches with light oil or rust inhibitor. A generous amount of lubrication, such as Polaris cable lubricant should be applied onto the rollers and weight pins. All lubrication applied as a rust preventative measure must be cleaned off before installing belt for service and operating machine.

Chaincase Lubricant

Change chaincase lubricant as outlined in this section. Remove the outer cover and clean the chaincase thoroughly.

MAINTENANCE/TUNE UP

Off Season Storage

Lubrication

Refer to page 2.6-2.11 for complete lubrication information.

To prevent corrosion, always grease jackshaft and drive shaft (clutch side) bearings with premium all season grease. Loosen driven clutch retaining bolt and pull clutch outward to expose bearing. Use a point type grease gun fitting to inject grease through hole in flange into bearing until grease purges out inside or outside bearing seal. Push clutch back on shaft and replace clutch retaining bolt. Inject grease into fitting on speedometer drive adaptor until grease purges out inside or outside bearing seal. Lubricate both front ski pivots at bushings and spindles. See III.1 and 2.

Polaris Premium All Season Grease

PN 2871423 14 1/2 oz.

Grease Gun Adapter: 2871174
Point Type

T-9 Metal Protectant

PN 2871064

Use T-9 Metal Protectant (or equivalent) on shock absorber shafts to help prevent corrosion.

Under normal conditions moderate track tension should be maintained during summer storage. Rubber track tension should be maintained at the prescribed normal operating tension specified in this manual. The rear of the machine should be supported off the ground to allow free hanging of track.

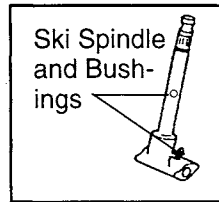

III. 1

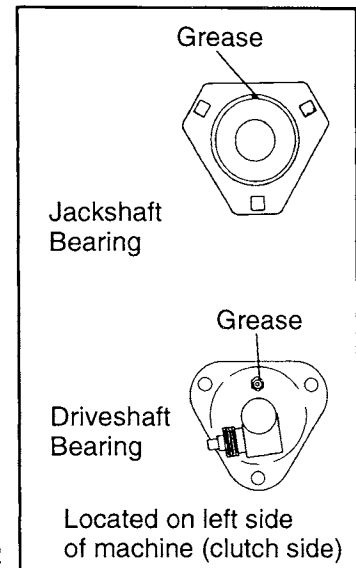

III. 2

Engine and Carburetor

Fog engine with Polaris Fogging Oil (aerosol type) according to directions on can. On models with carburetor vacuum fittings the fogging oil can be sprayed through the fitting.

If you choose not to use Polaris Fogging Oil perform the following procedure: Support front of snowmobile so engine is level or tilted slightly rearward. Remove spark plug(s). Rotate piston to BDC and pour approximately two ounces (16 ml) Polaris 2-Cycle Injector oil into the cylinder. **NOTE:** Allow ample time for oil to flow from top of piston down transfer ports and onto crankshaft bearings before proceeding to next cylinder. Turn engine over several times to insure coverage of piston rings, cylinder walls and crankshaft bearings. See photo at right.

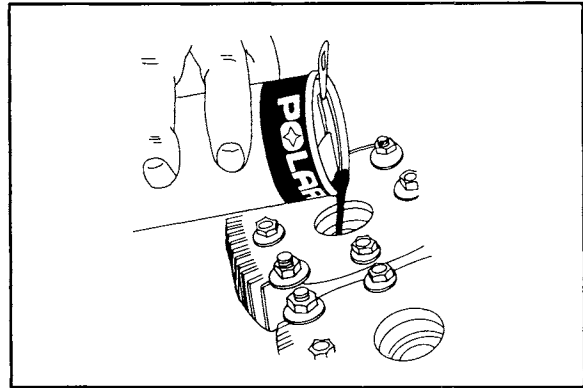

Polaris Fogging Oil PN 2870791

Carbon Clean PN 2871326

Treat the fuel system with Polaris Carbon Clean.

If Polaris fuel system additive is not used, fuel tank, fuel lines, and carburetor should be completely drained of gasoline. To eliminate any fuel remaining in the carburetor, run the engine until it stops.

Battery

Disconnect and remove battery. Fill with distilled water. Clean terminals and cables. Apply dielectric grease. Charge until specific gravity is at least 1.270 (each cell). If machine is to be stored for one month or longer, fill and charge battery monthly using Polaris Battery Tender, or a 1 amp trickle charger to maintain at 1.270 specific gravity.

Polaris Battery Tender

PN 2871076

Exhaust System

At approximately 2000 miles, or in preparation of off season storage, it is a good idea to check the exhaust system for wear or damage. To inspect, allow the engine and exhaust system to cool completely. Open the hood and inspect the muffler and pipes for cracks or damage. Check for weak or missing retaining springs or damper/support grommets.

▲ WARNING

Exhaust system temperatures can exceed 900° F (500° C). Serious burns may occur if this inspection is performed without allowing adequate time for the exhaust system to cool. Never perform this procedure with the engine running.

MAINTENANCE/TUNE UP Variable Exhaust System

Variable Exhaust System (V.E.S.)

Some snowmobiles are equipped with the Polaris (patent pending) *Variable Exhaust System (V.E.S.)*

This unique exhaust valve management system changes the effective exhaust port height in the cylinder to provide maximum horsepower at high RPM without sacrificing fuel economy and engine torque at low to midrange throttle settings.

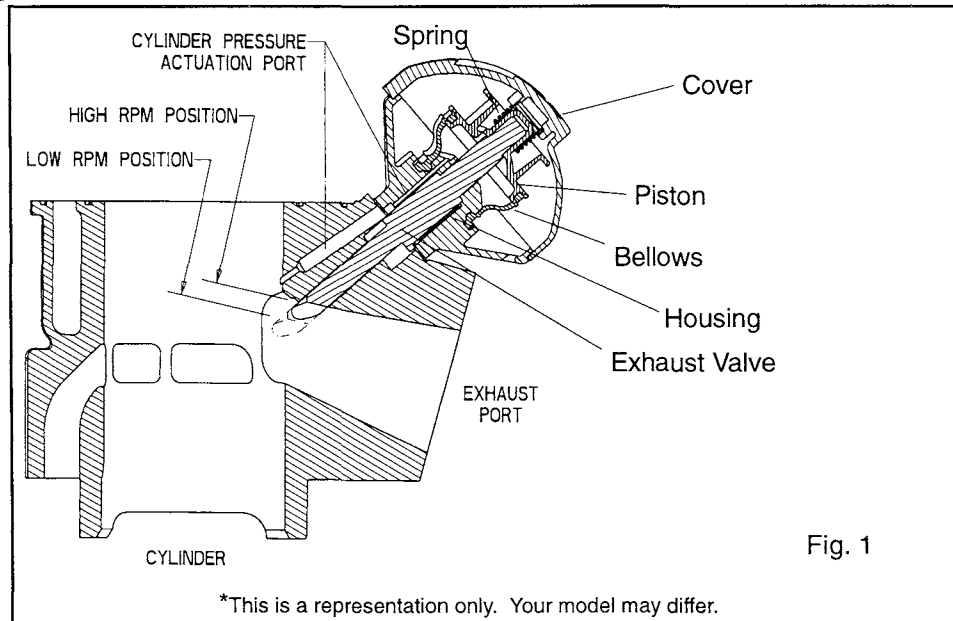

In order to understand the operation and function of the V.E.S. we must first consider the characteristics of a two stroke engine. The height of the exhaust port in a two stroke engine cylinder has an affect on the total power output of an engine, as well as the RPM at which the power occurs.

Exhaust systems are "tuned" by design to match engine exhaust port configuration and desired power delivery characteristics. Engines with relatively "high" exhaust ports (and exhaust pipe to match) produce more horsepower at high RPM, but only at the expense of low to midrange fuel economy and torque. On the other hand, "low" port engines provide good fuel economy in the midrange and make their power at relatively lower RPM, but will not produce as much peak horsepower for a given displacement range. In general, an engine designed for a racing or high performance snowmobile will have a relatively high exhaust port compared to an engine of the same displacement range designed for touring.

Although the V.E.S. does not in itself increase horsepower, it does allow an engine to be designed for maximum horsepower without the inherent disadvantages of a high exhaust port.

The main components of the V.E.S. are the exhaust valve, valve housing, bellows, piston, return spring, and cover.

A guillotine style exhaust valve is connected to a moveable piston. This piston is attached to a flexible bellows, forming two chambers. The lower chamber is connected to the cylinder by a drilled passageway located just above the exhaust port. The upper chamber is vented to atmospheric pressure. A valve return spring is located in the upper chamber between the piston and cover.

At idle and low speeds, the exhaust valve is held in the "low port" position by the return spring. When throttle is applied (and RPM begins to increase) rising cylinder pressure is applied to the under side of the bellows via the actuation port. This forces the exhaust valve upward against spring pressure. The valve continues to move upward toward the "High Port" position as cylinder pressure, horsepower, and RPM increase.

MAINTENANCE/TUNE UP Variable Exhaust System

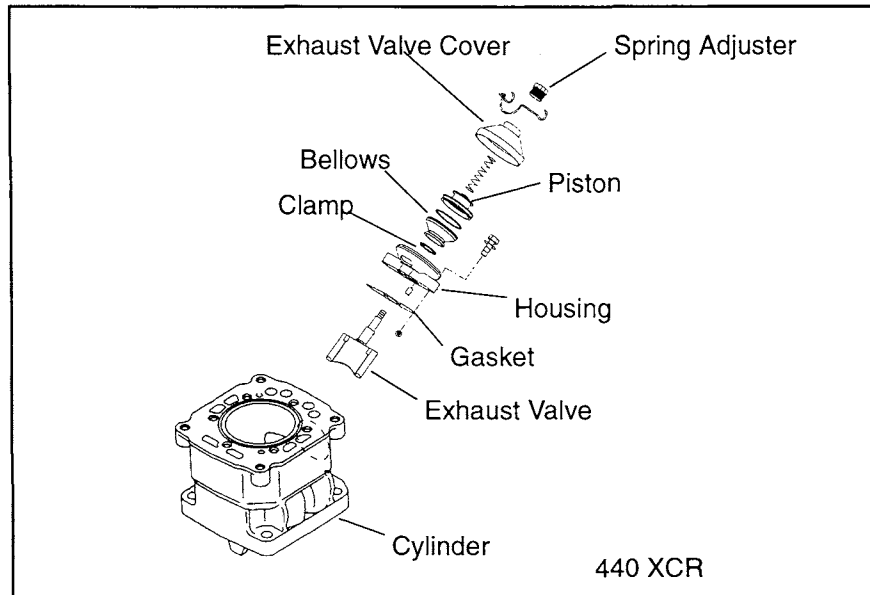

V.E.S. Maintenance

Due to the simplicity of V.E.S. design, maintenance is limited to a periodic inspection and cleaning of system components. The V.E.S. should be disassembled, inspected, and cleaned (remove carbon deposits) every 1000 to 2000 miles, depending on operating conditions. To ensure maximum performance and minimize required maintenance, Polaris recommends the use of Premium Gold Synthetic 2 Cycle lubricant (PN 2871721) only. The use of other lubricants may cause improper function of the valve mechanism, and increase the frequency of required cleaning due to excessive buildup of carbon deposits.

NOTE: To ensure maximum performance and minimize required maintenance, break in the engine using Polaris TC-W3 oil (premix and injection tank) and then switch to Polaris Premium Gold Synthetic 2 cycle lubricant.

V.E.S. Removal and Cleaning

For VES removal and cleaning, refer to 440/500 Domestic Case Reed Twin and 700/800 XCR section in chapter 3, Engines.

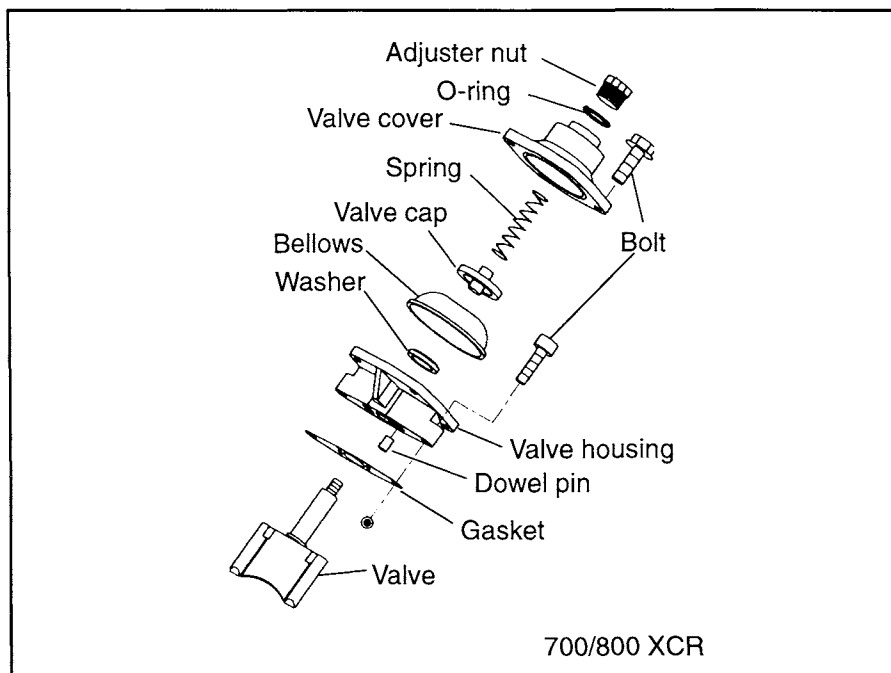

MAINTENANCE/TUNE UP
Variable Exhaust System

V.E.S. Troubleshooting

Symptom	Possible Cause	Remedy
Engine will not reach designed operating RPM	Valve not opening or not opening completely: 1. Exhaust valve sticking 2. Cylinder pressure feed port restricted 3. Bellows damaged or not sealing correctly 4. Incorrect spring 5. Problem in clutch setup, drive line, engine, etc.	1. Remove carbon deposits, burrs etc. 2. Clean port 3. Inspect bellows, fastener straps, and gasket and repair as required 4. Inspect 5. Inspect
Poor acceleration; hesitation; High RPM performance is normal or near normal	Valve opening too early: 1. Valve sticking open or partially open 2. Broken, damaged, or incorrect, spring	1. Clean, Inspect 2. Inspect, Replace

MAINTENANCE/TUNE UP Hood - Alignment - Evolved

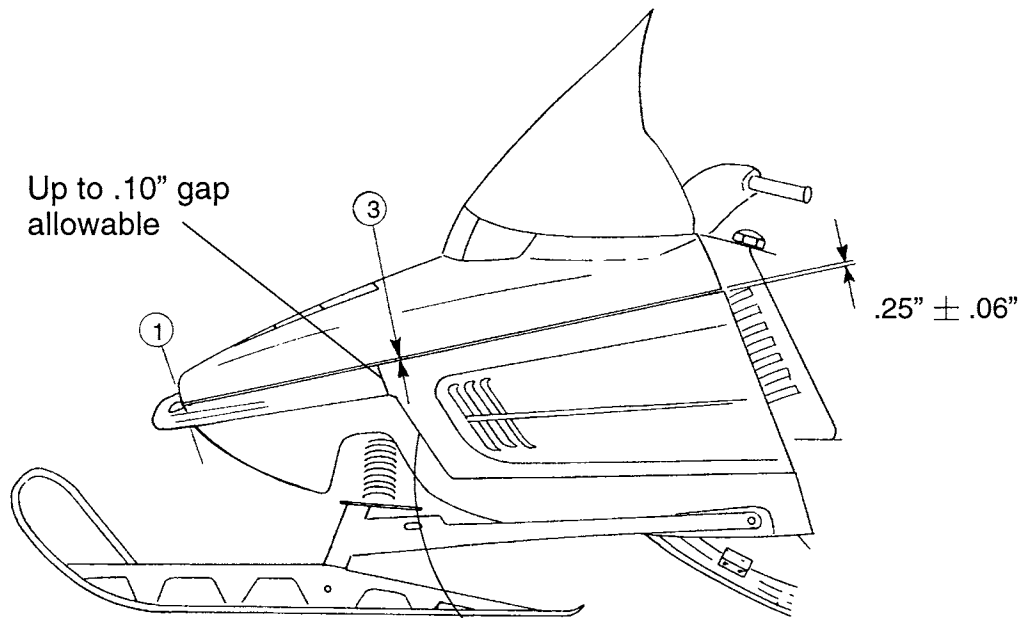

Avoid pucker in this area.

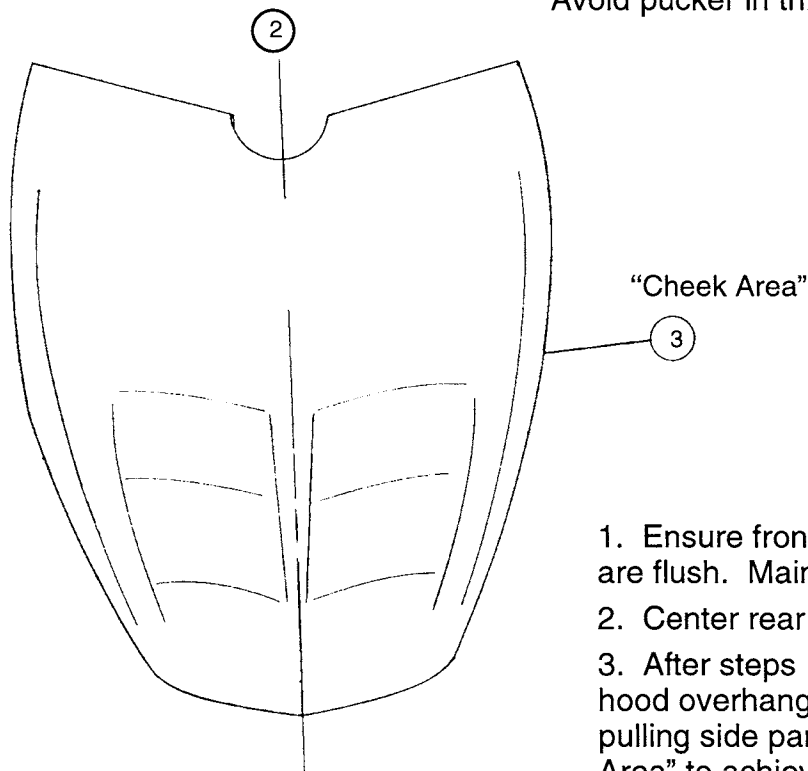

1. Ensure front of hood and side bumper are flush. Maintain $.25" \pm .06"$ gap.
2. Center rear of hood to console.
3. After steps 1 & 2 are complete, adjust hood overhang (if needed) by pushing or pulling side panel at bracket in "Cheek Area" to achieve required gap.

MAINTENANCE/TUNE UP
Side Bumper, Panel and Console Mounting - Evolved

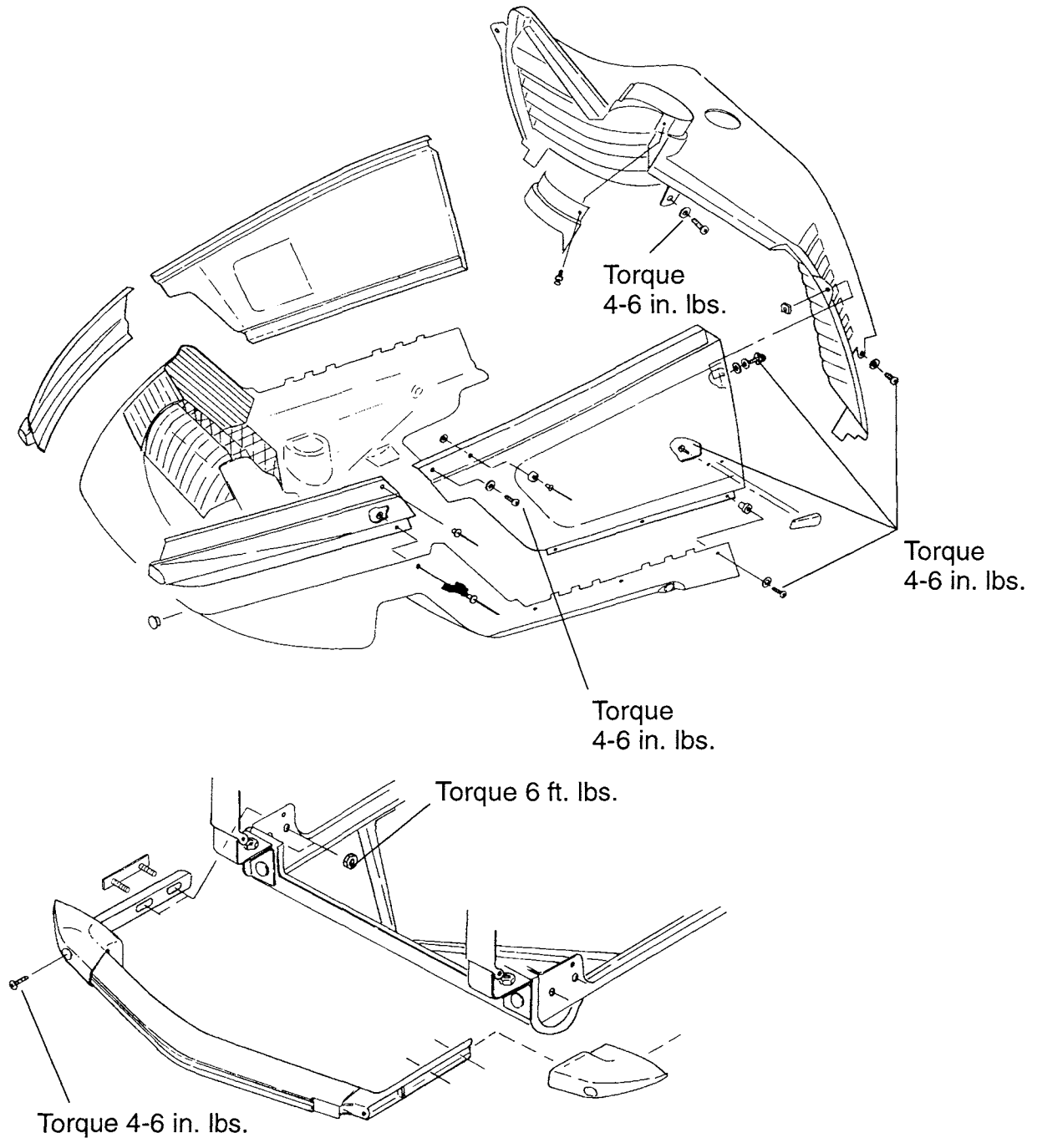

MAINTENANCE/TUNE UP Handlebar Assembly - Evolved, Aggressive

Handlebar cable
tie location

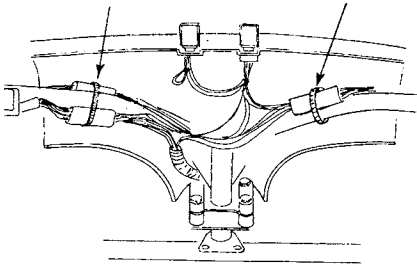

When adjusting the handlebars, tighten all screws evenly until bars are held in the desired position. Torque the front handlebar screws first and then the rear screws (11-13 ft. lbs.).

NOTE: The slightly wider gap at the rear of the block is normal.

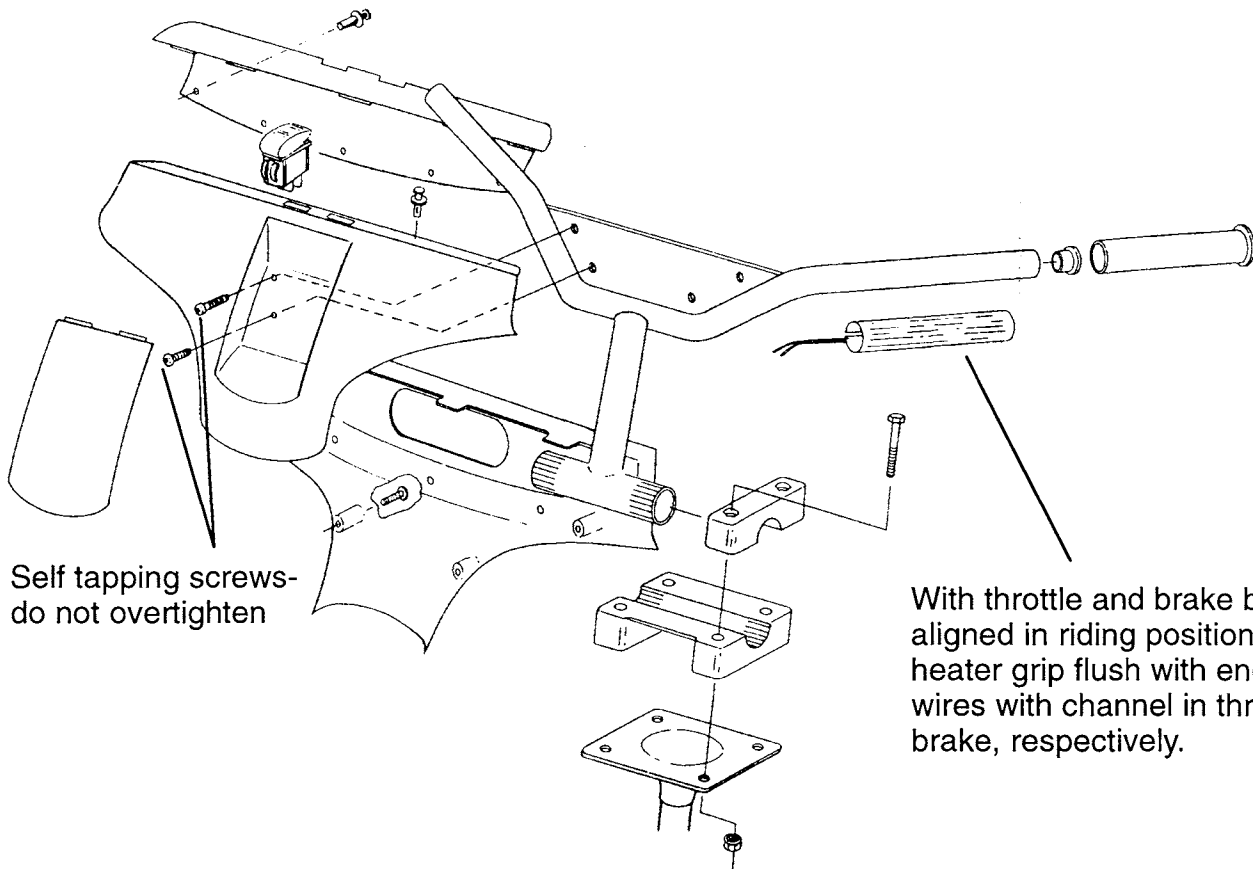

Self tapping screws-
do not overtighten

With throttle and brake blocks
aligned in riding position, position
heater grip flush with end. Align
wires with channel in throttle and
brake, respectively.

MAINTENANCE/TUNE UP
Routing Diagram - 340, 340 Deluxe, 340 Touring

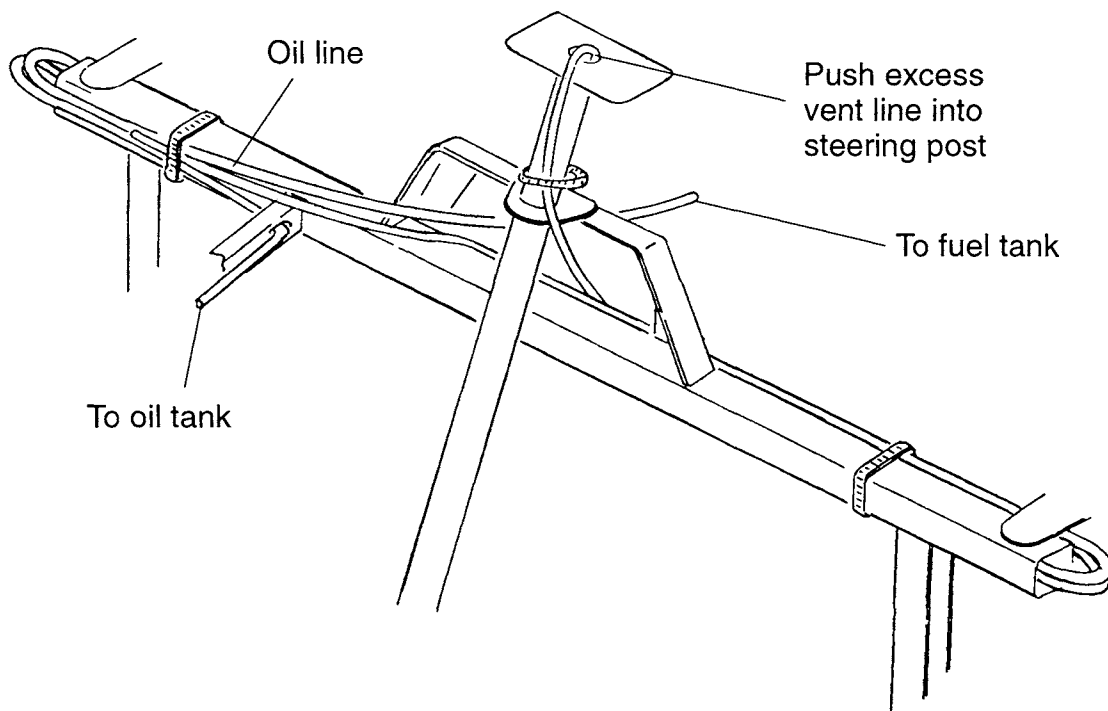

MAINTENANCE/TUNE UP
Oil Line Routing, 340 - 340 Touring

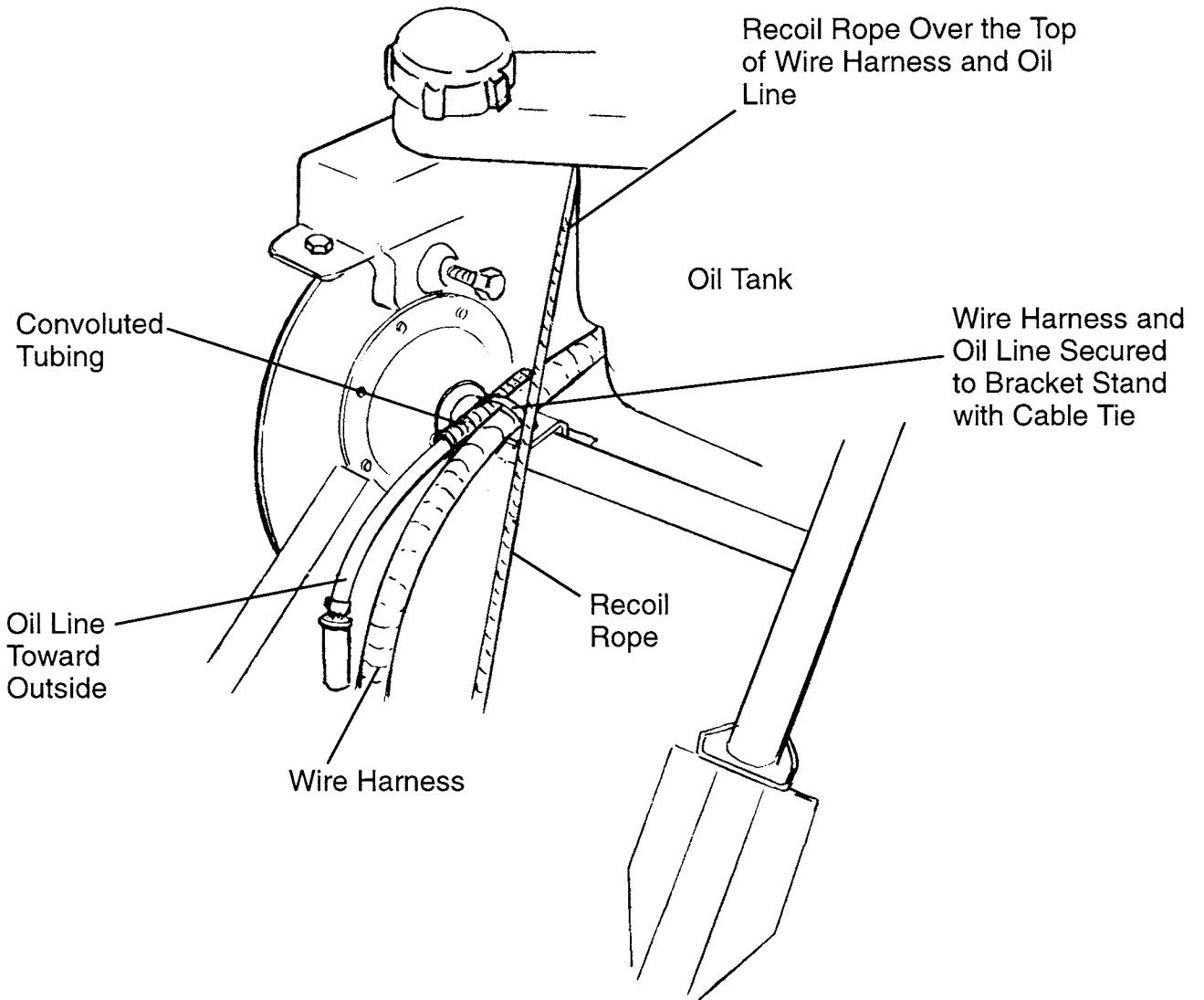

MAINTENANCE/TUNE UP
Oil Line Routing - 340 Deluxe

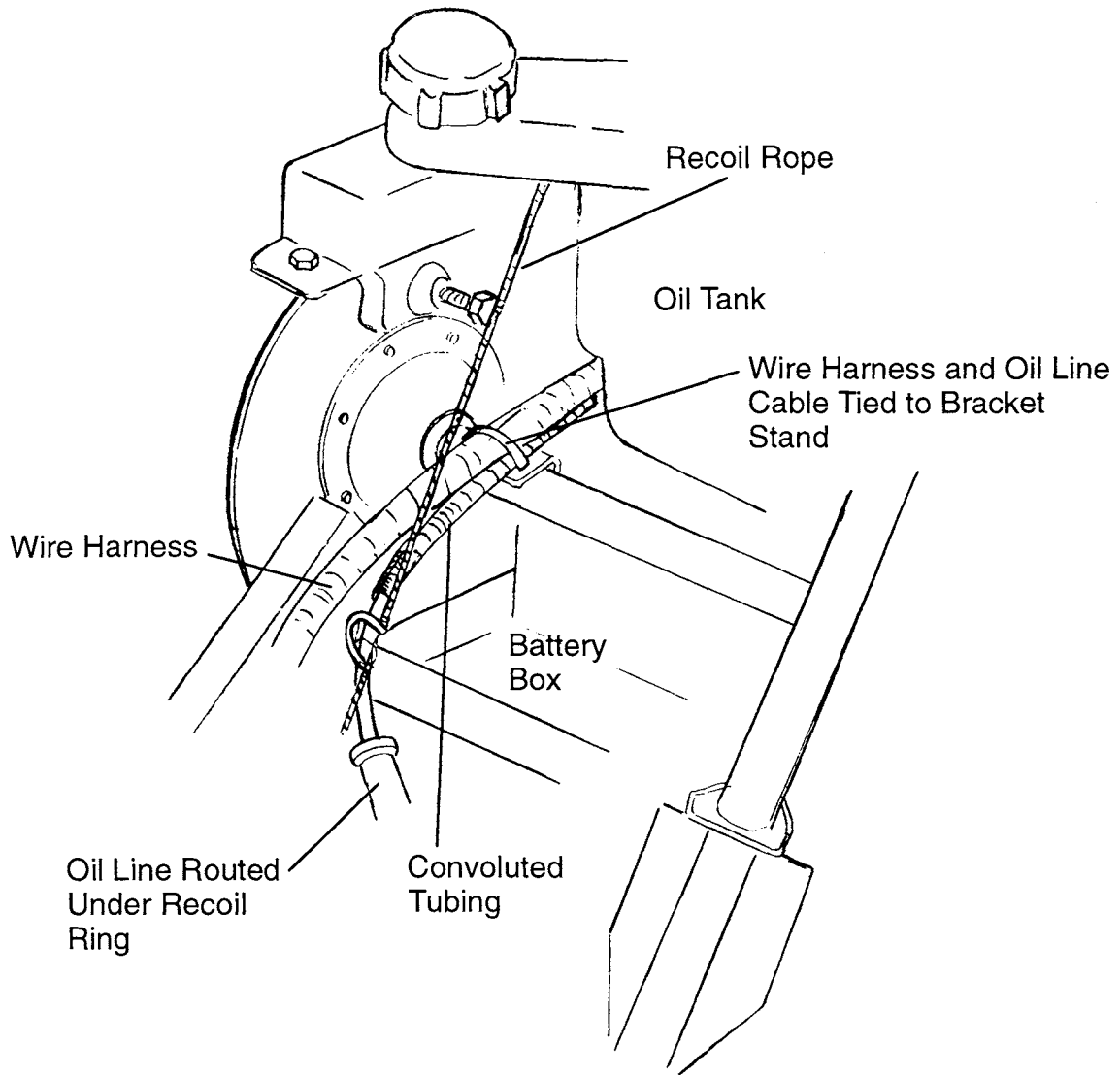

NOTE: Be sure not to kink or pinch oil line.

MAINTENANCE/TUNE UP
Fuel Tank / Oil Tank Vent Line Routing - Sport, Sport Touring, TranSport

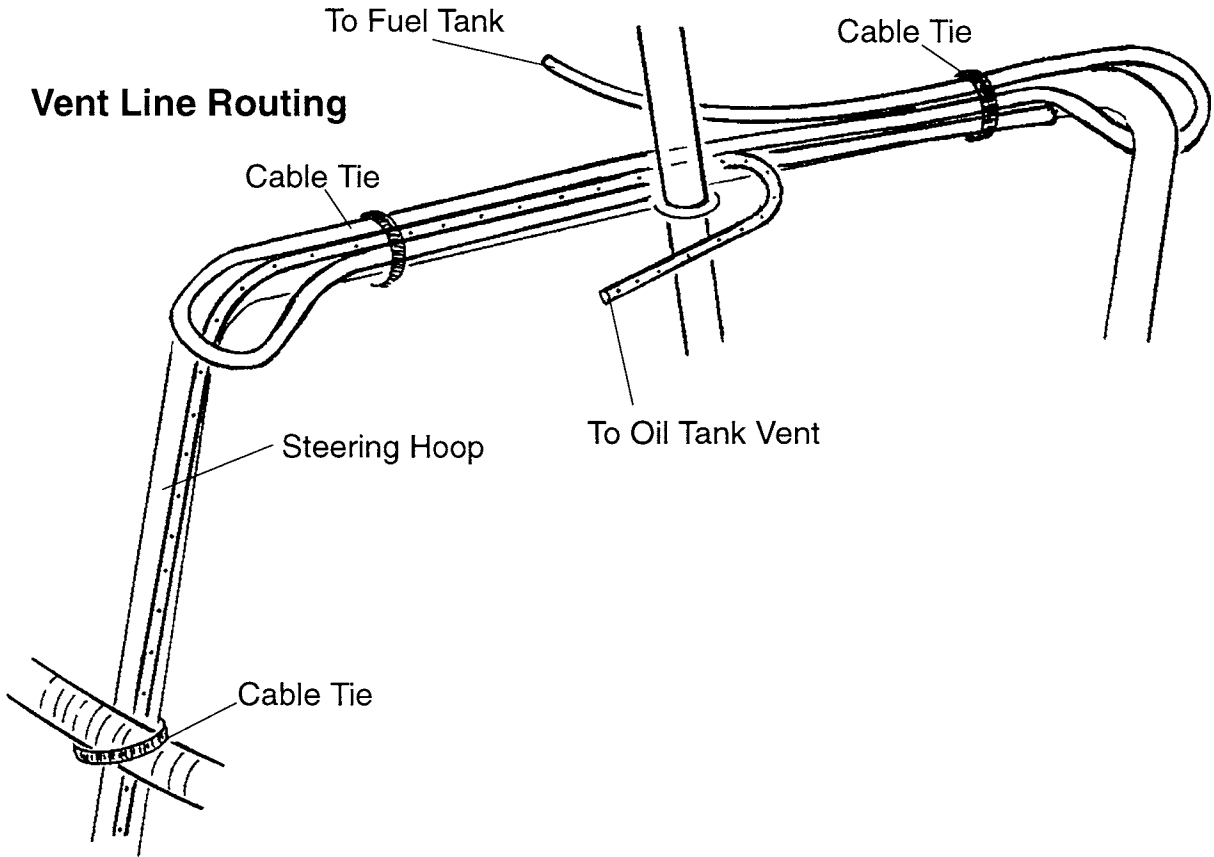

MAINTENANCE/TUNE UP
Fuel Pump and Fuel Line Routing - Sport, Sport Touring, TranSport

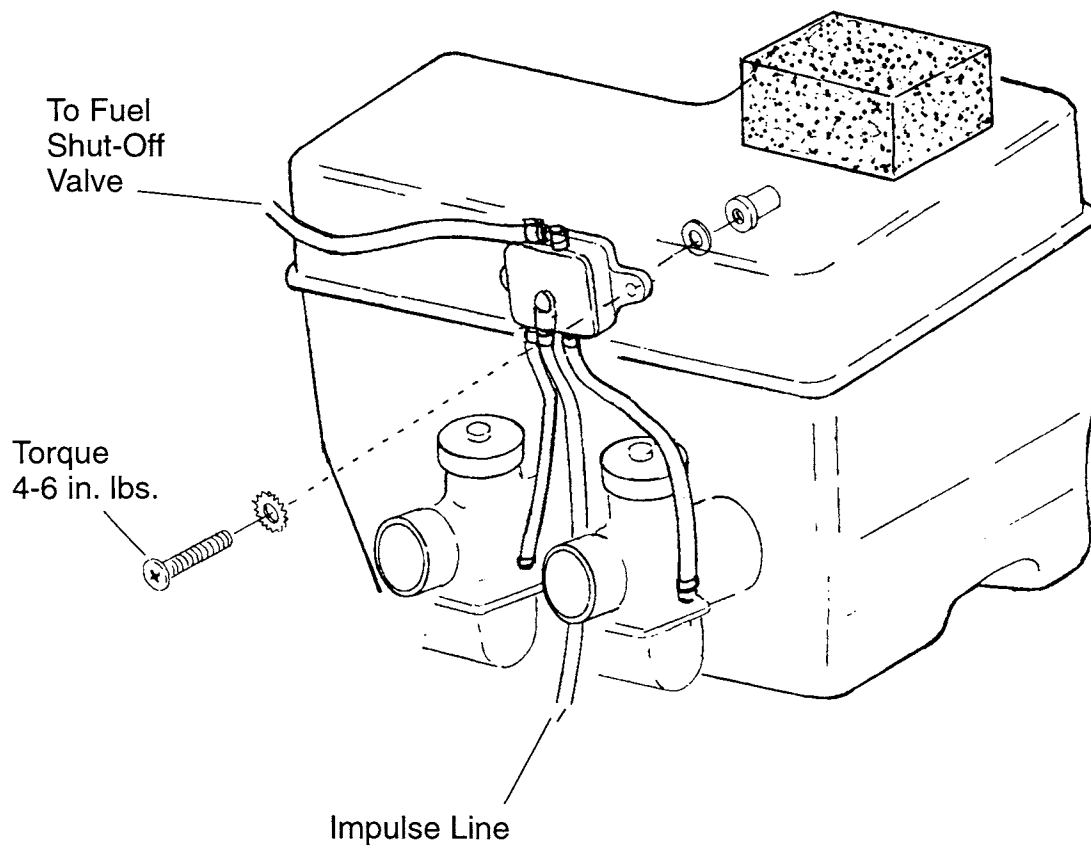

MAINTENANCE/TUNE UP
Fuel Tank/Oil Tank Vent Line Routing - XCF, Super Sport

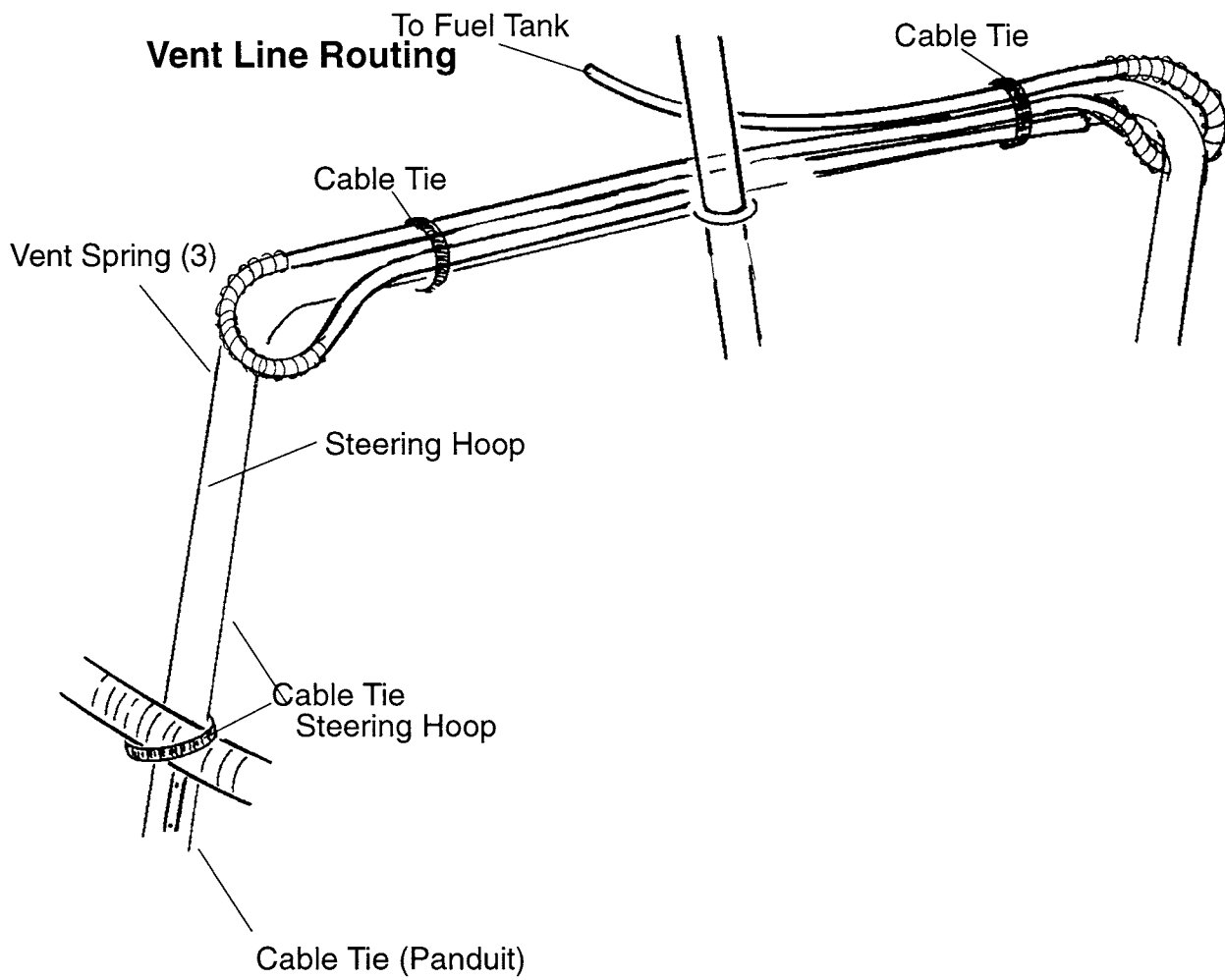

MAINTENANCE/TUNE UP
Carburetor Vent Line Routing - Super Sport

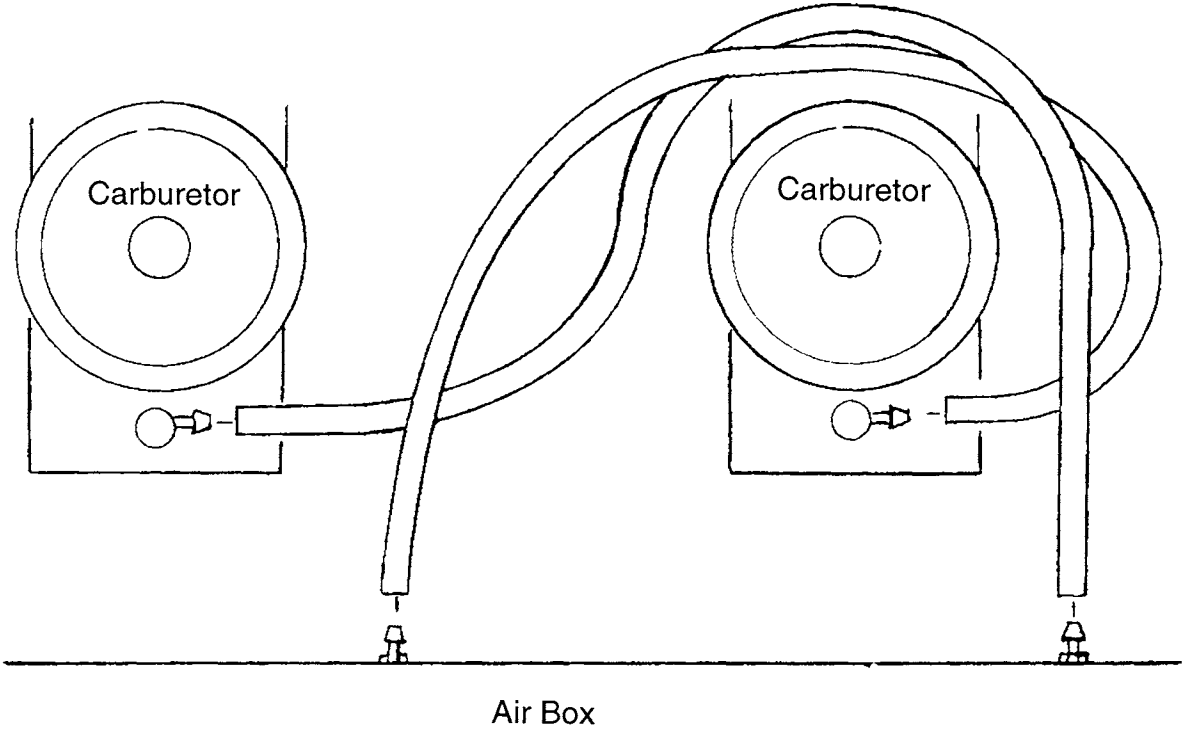

MAINTENANCE/TUNE UP
Fuel Tank/Oil Tank Vent Line Routing - Trail, Trail Touring

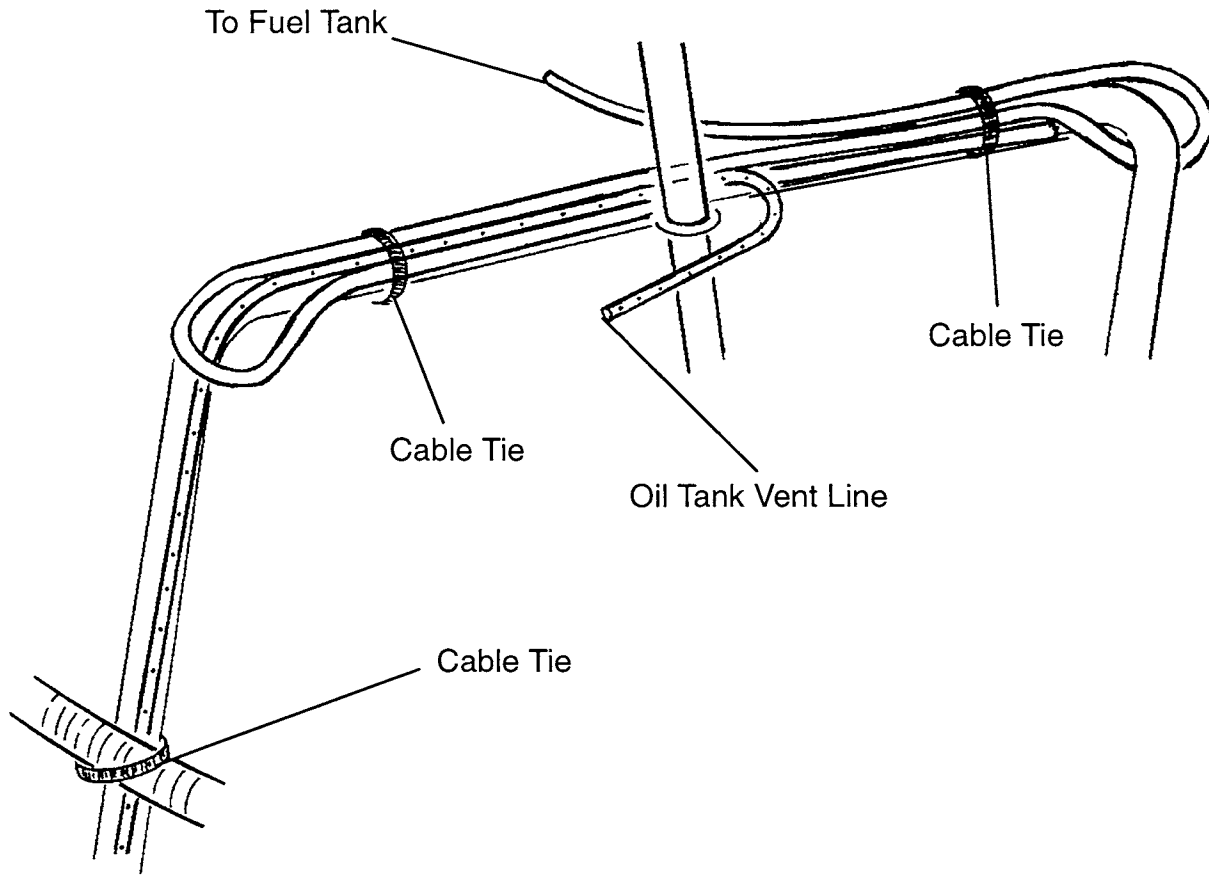

MAINTENANCE/TUNE UP

Wire Harness And Speedometer Cable Routing - Trail, Trail Touring

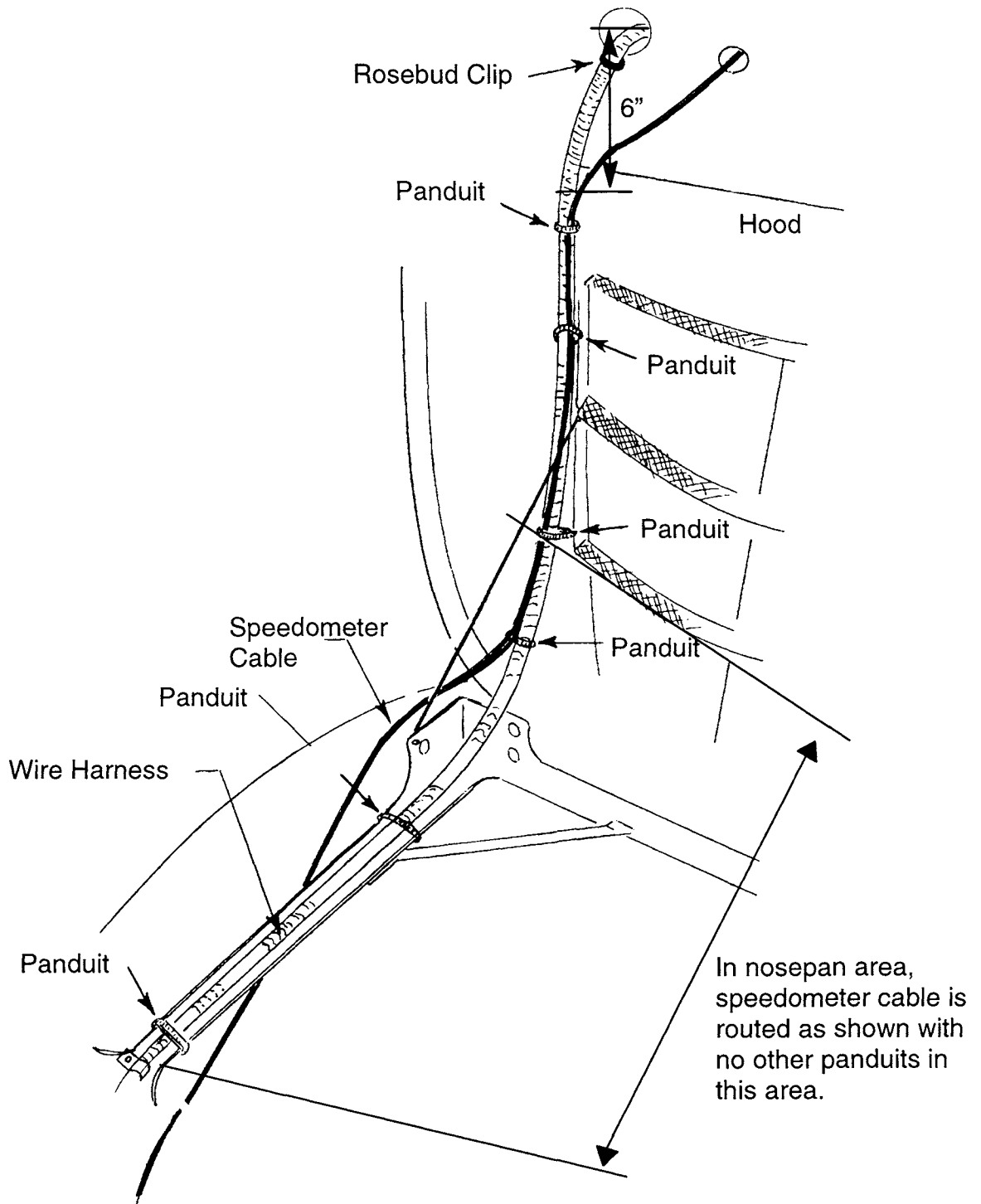

MAINTENANCE/TUNE UP
Fuel Pump and Fuel Line Routing - Trail, Trail Touring

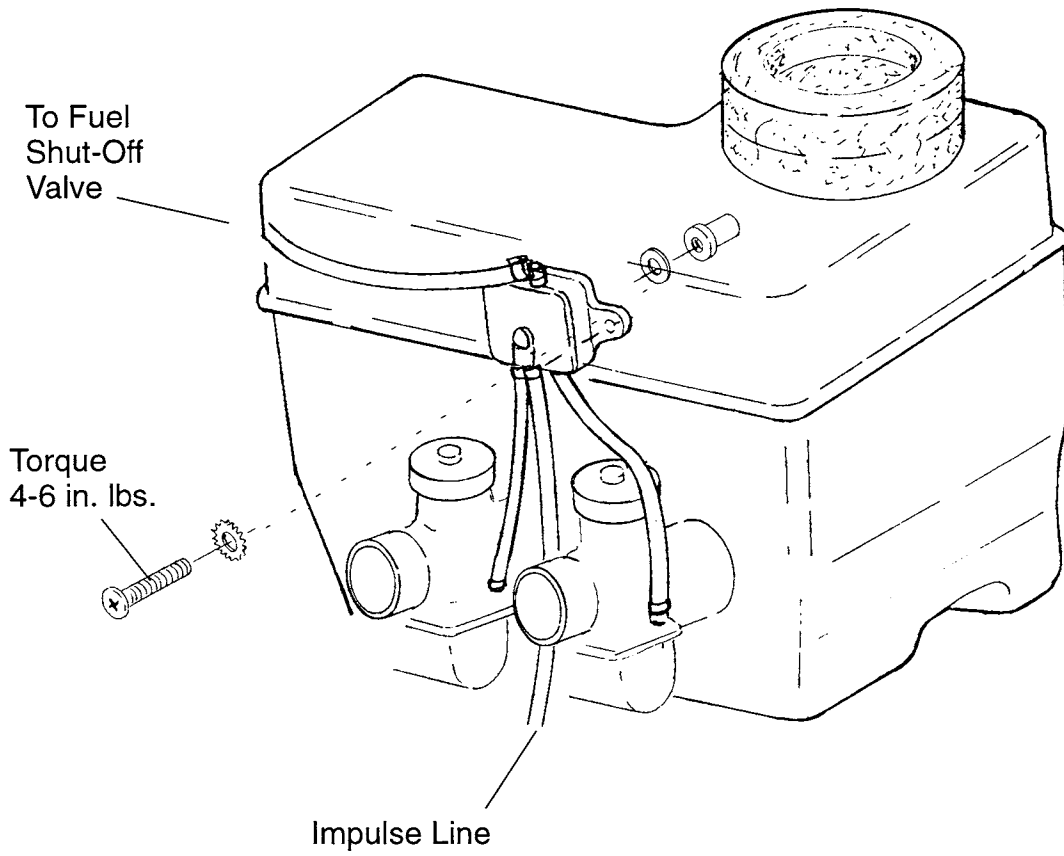

MAINTENANCE/TUNE UP
Carburetor Vent Line Routing - Trail, Trail Touring

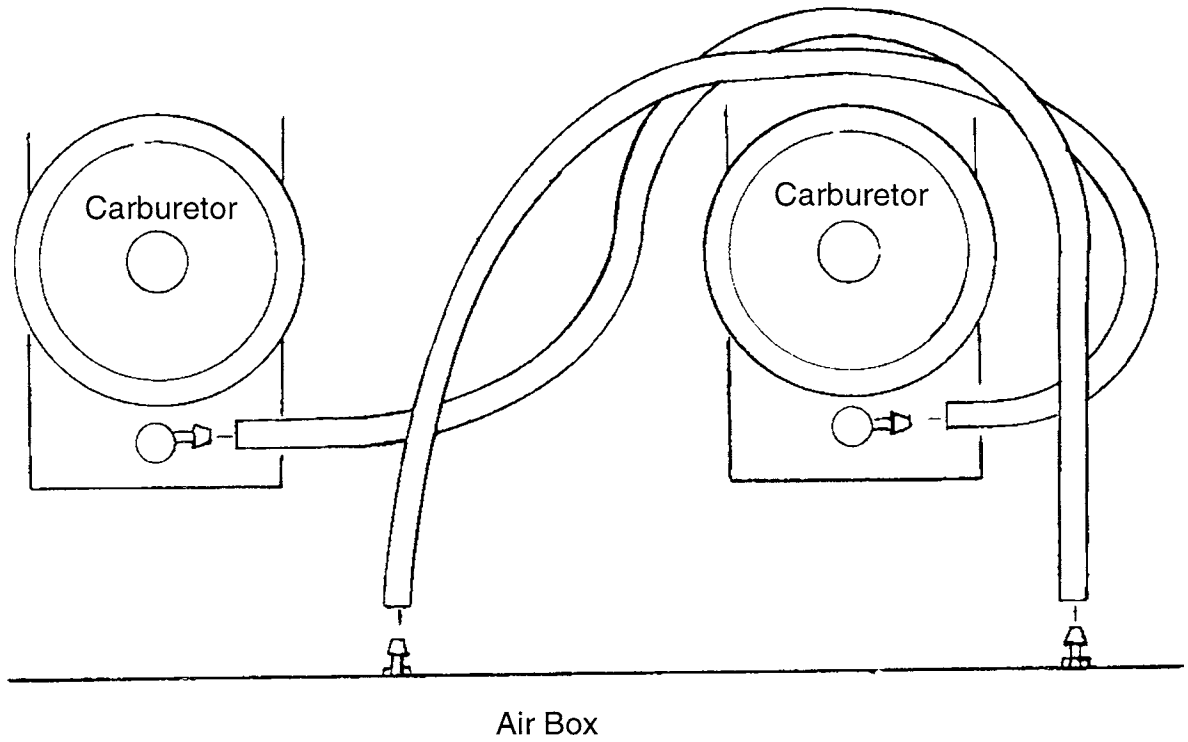

MAINTENANCE/TUNE UP
Fuel Tank/Oil Tank Vent Line Routing - 500, 500 Classic, Classic Touring

Vent Line Routing

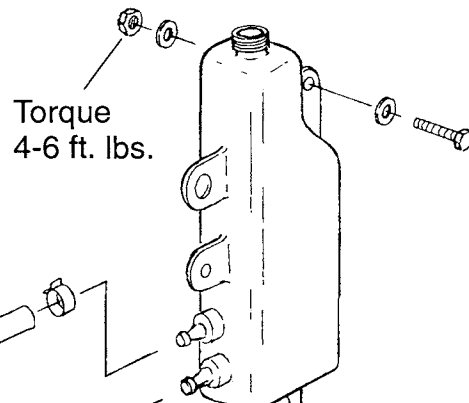
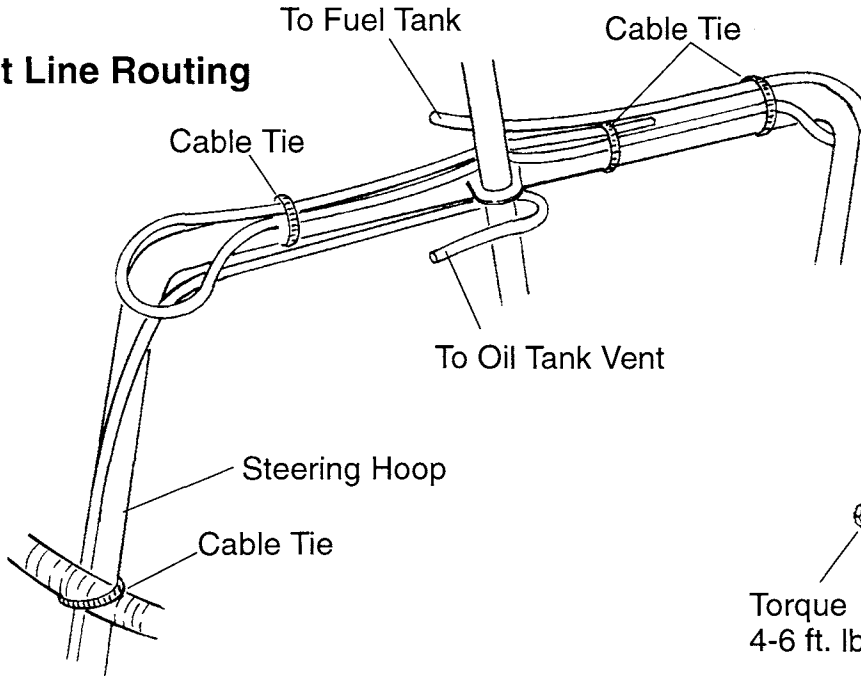

Coolant Bottle & Hose

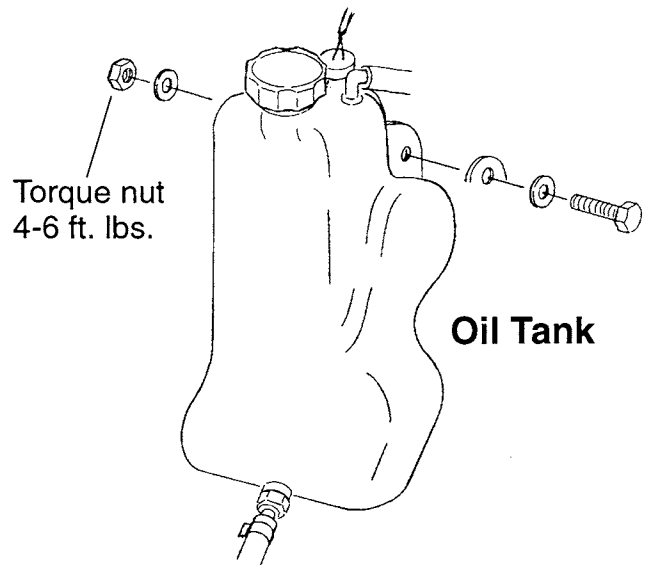
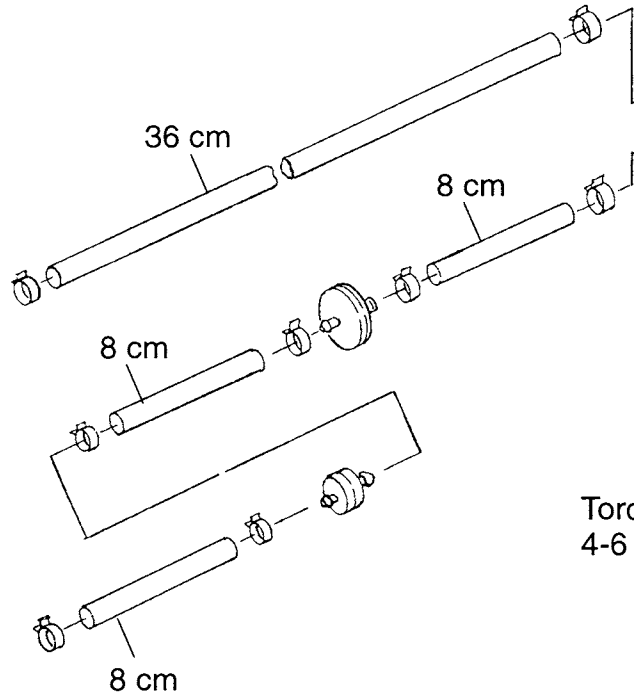

Oil Tank

MAINTENANCE/TUNE UP

Wire Harness and Speedometer Cable Routing - 500, 500 Classic, Classic Touring

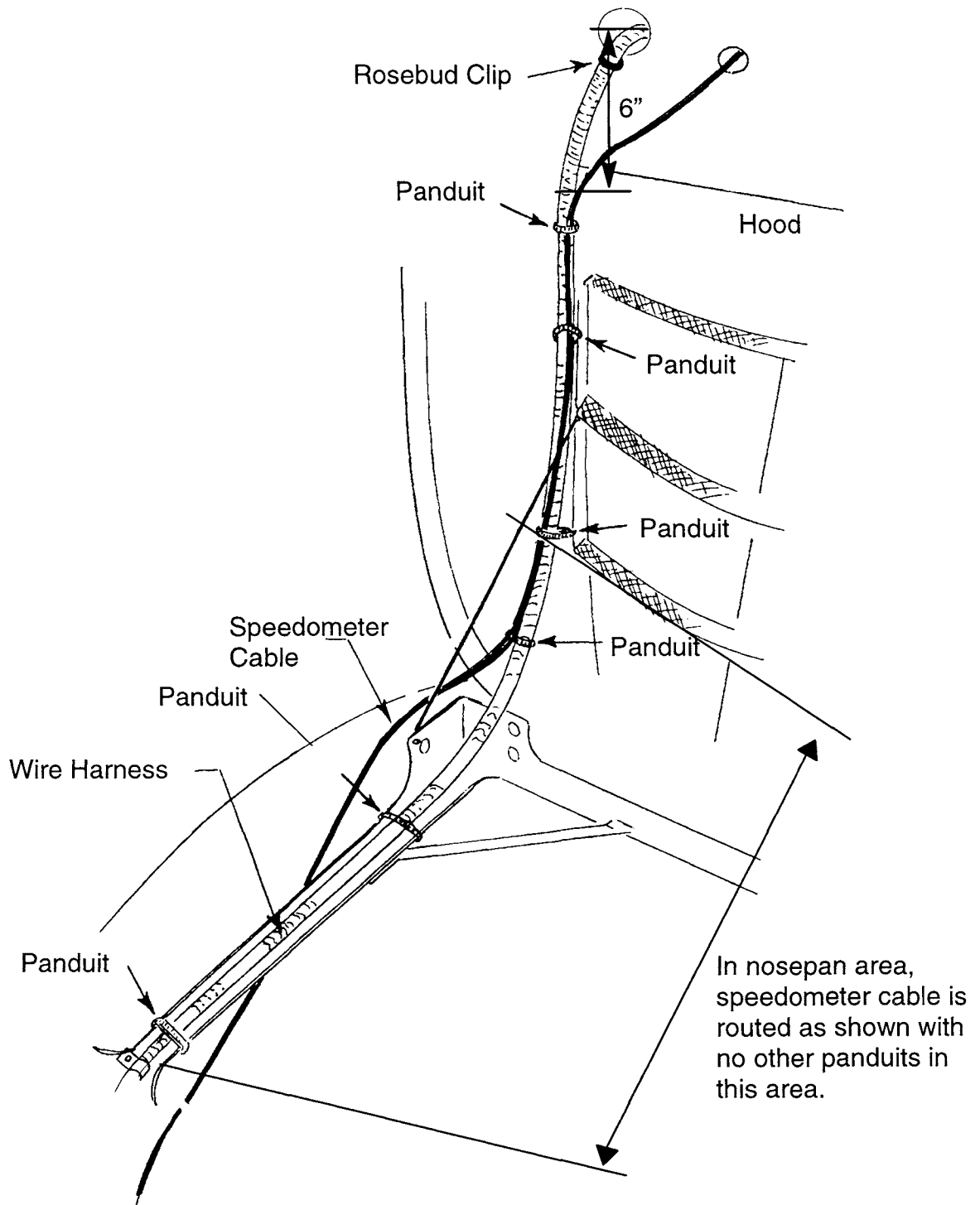

MAINTENANCE/TUNE UP
Fuel Pump and Fuel Line Routing - 500, 500 Classic, Classic Touring

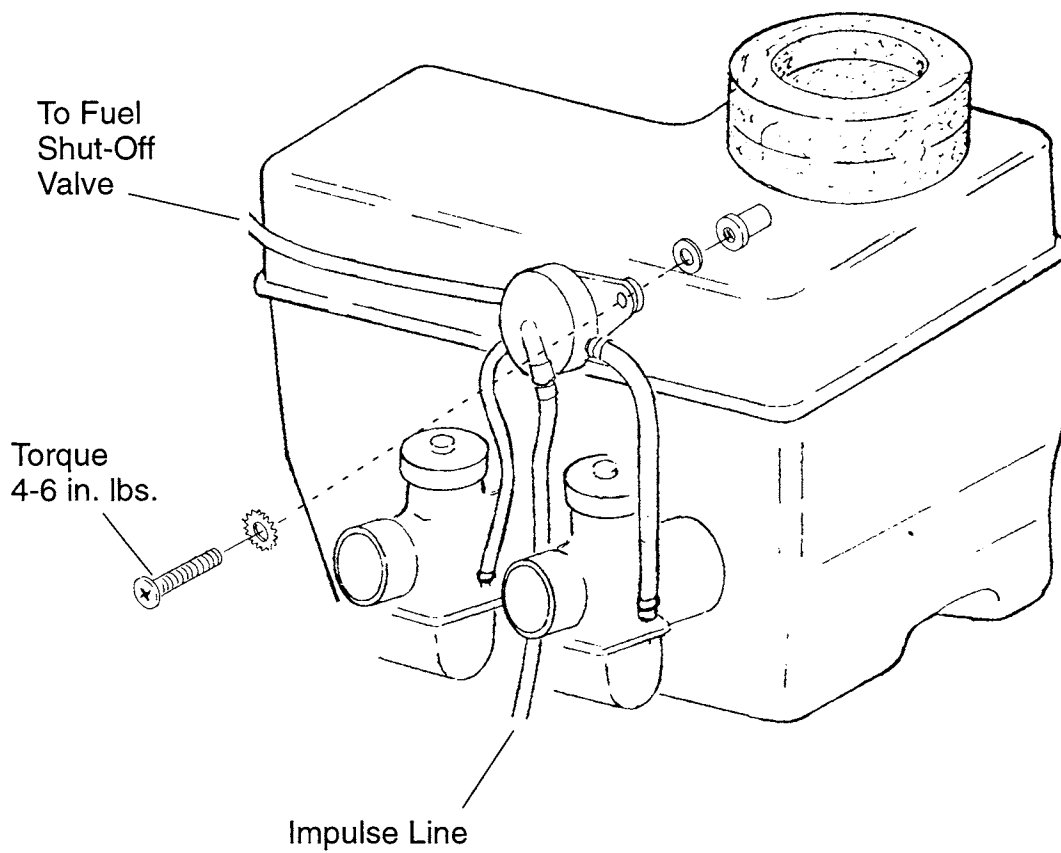

MAINTENANCE/TUNE UP
Carburetor Vent Line Routing - 500, 500 Classic, Classic Touring

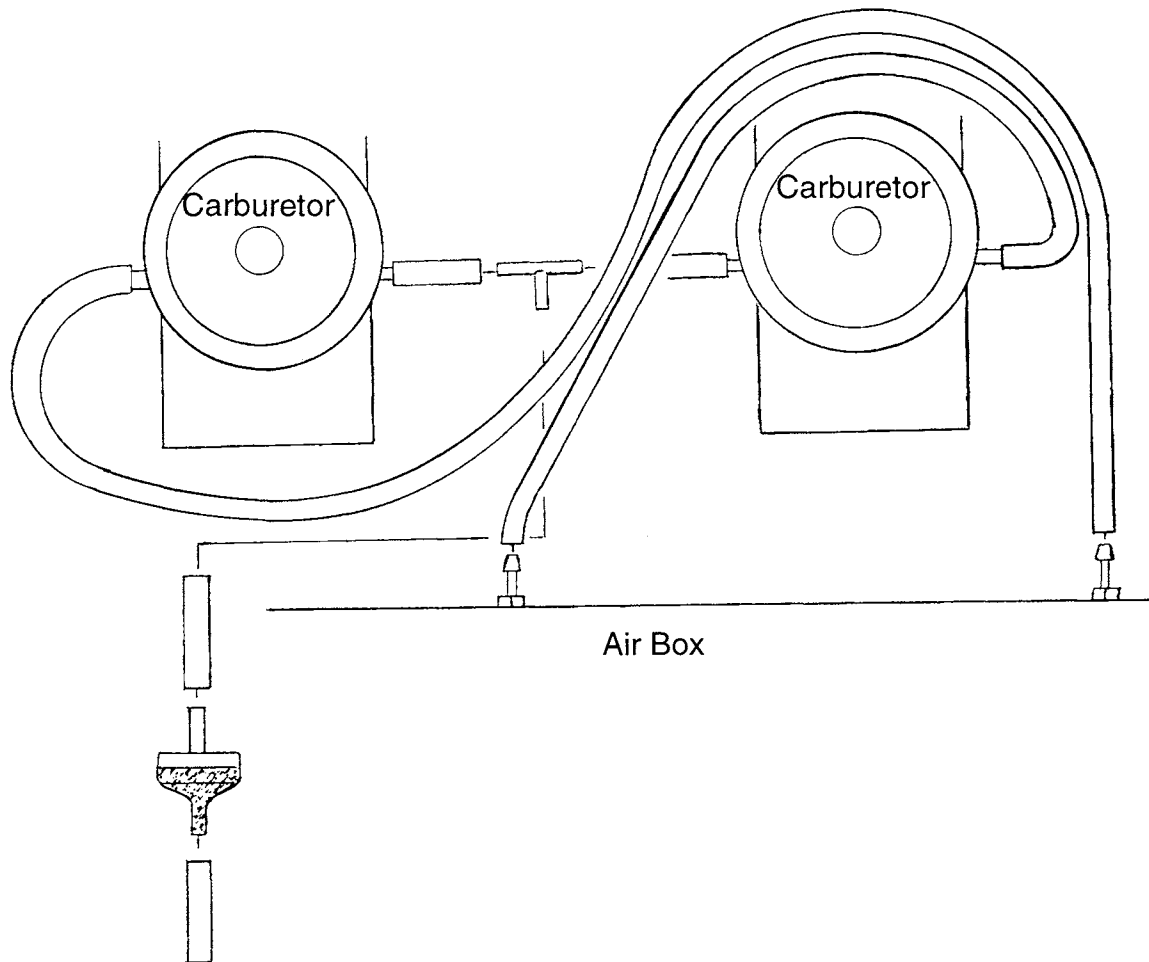

MAINTENANCE/TUNE UP
Cooling System - 500, 500 Classic, Classic Touring

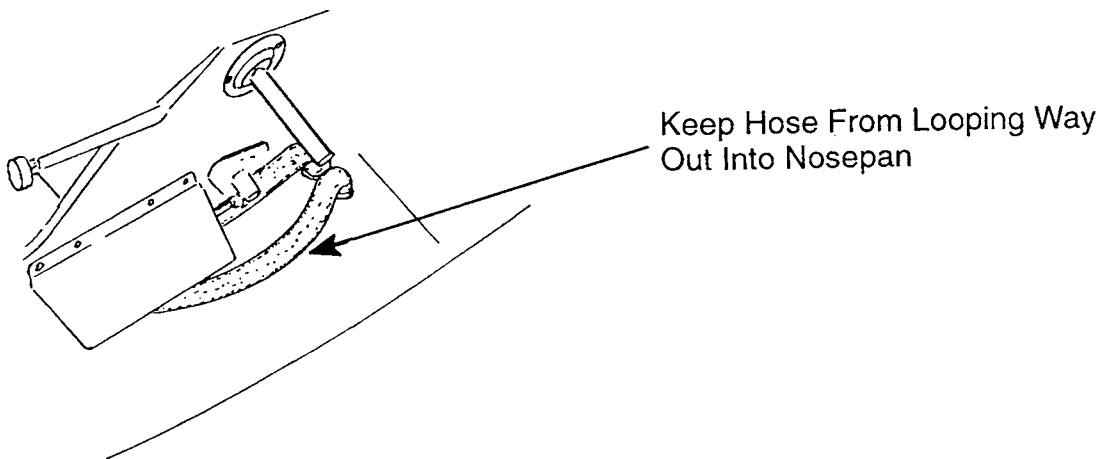
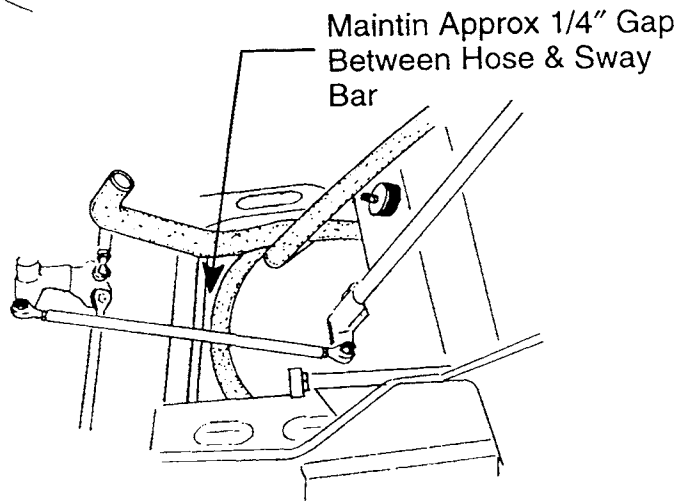
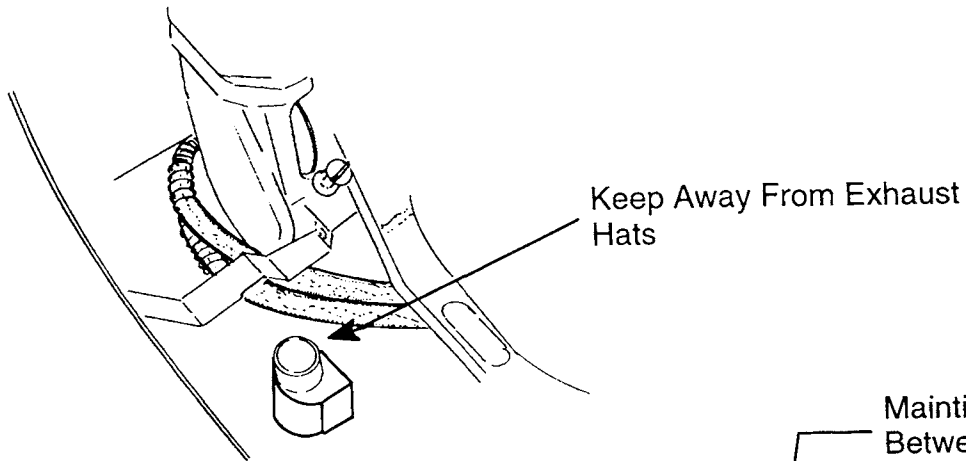

MAINTENANCE/TUNE UP
Fuel Pump and Fuel Line Routing - Widetrak LX

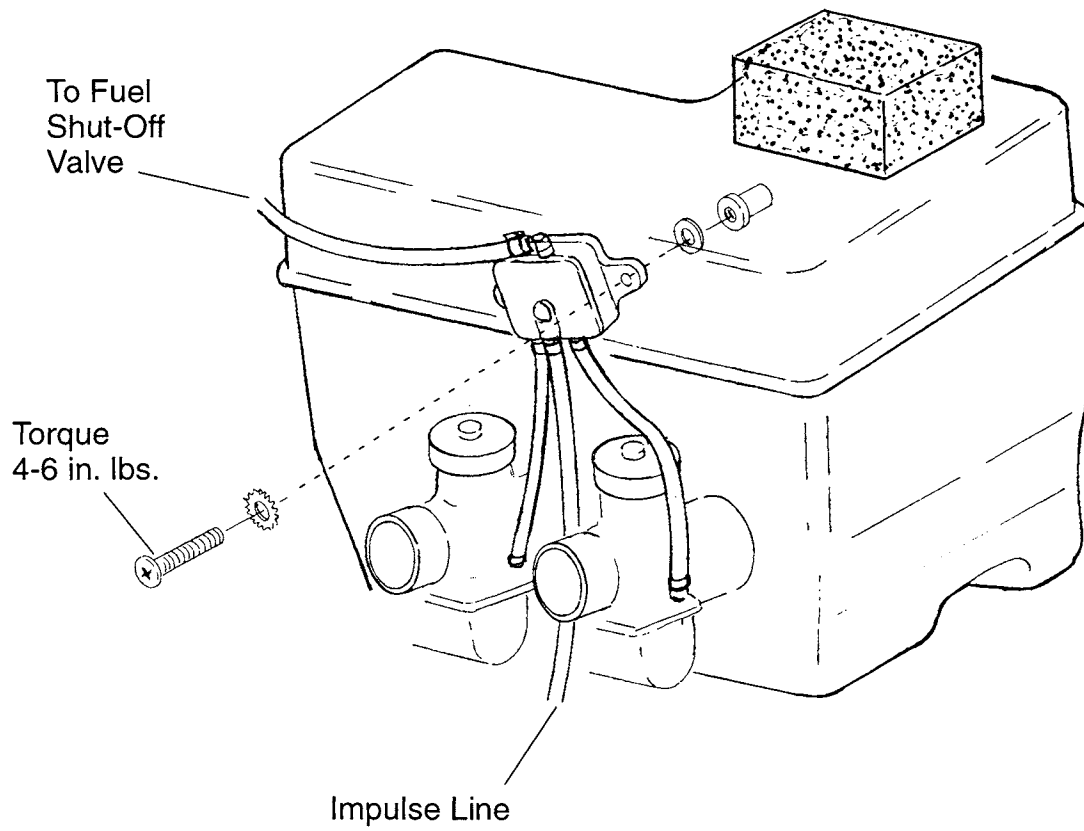

**MAINTENANCE/TUNE UP
Cooling System - Widetrak LX**

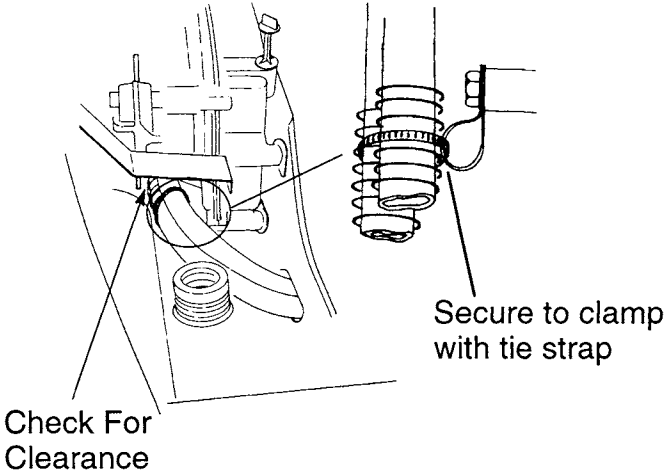

Maintain approx. 1/4" gap between hose and sway bar

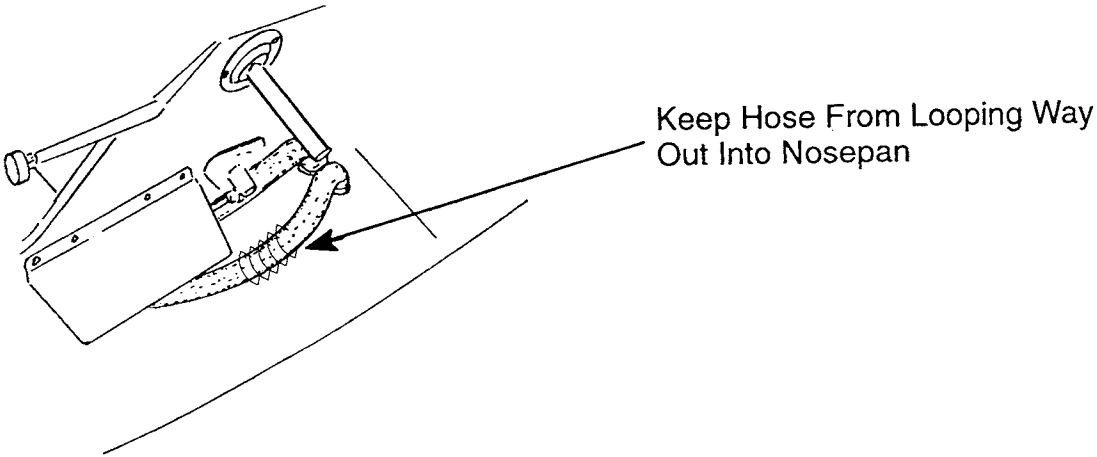
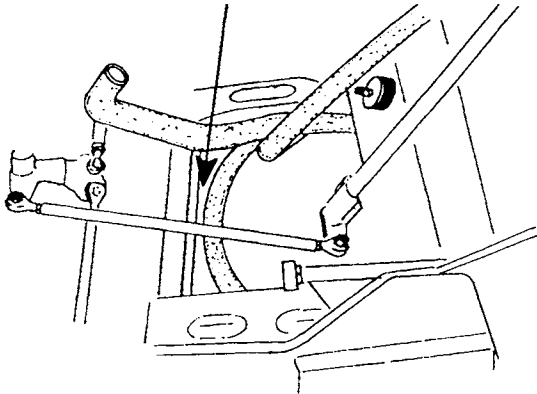

MAINTENANCE/TUNE UP
Fue Tank/Oil Tank Routing - Widetrak LX

Vent Line Routing

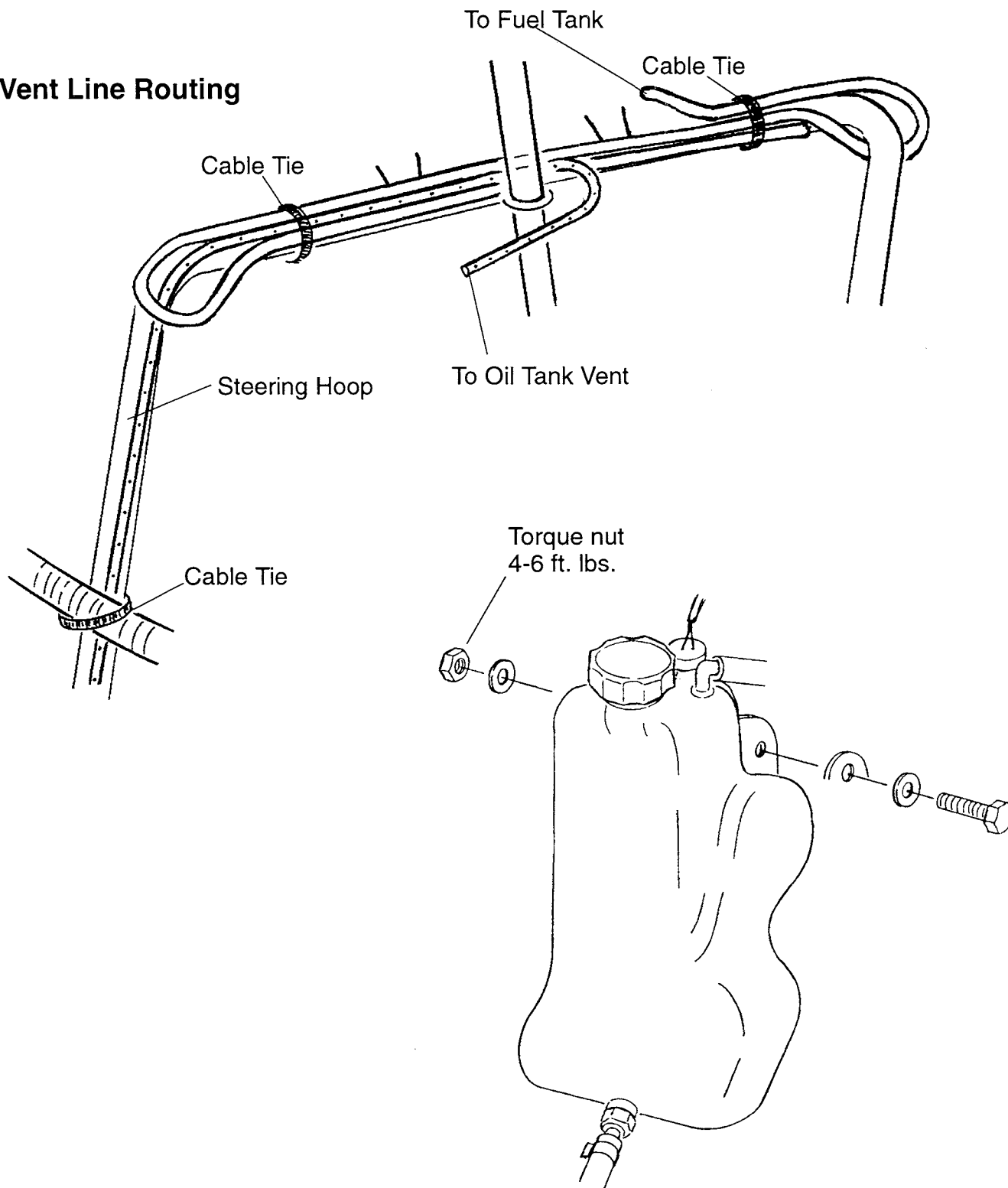

MAINTENANCE/TUNE UP
Fuel Tank / Oil Tank Vent Line Routing - XLT Classic, XLT Touring, XLT Special

Vent Line Routing

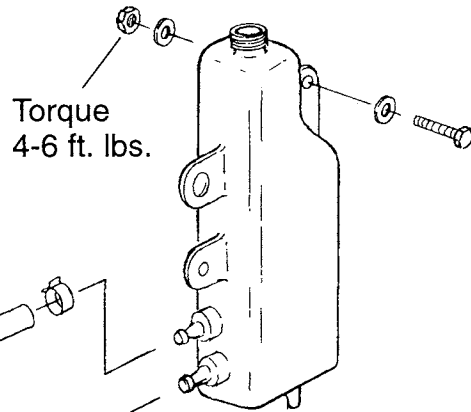
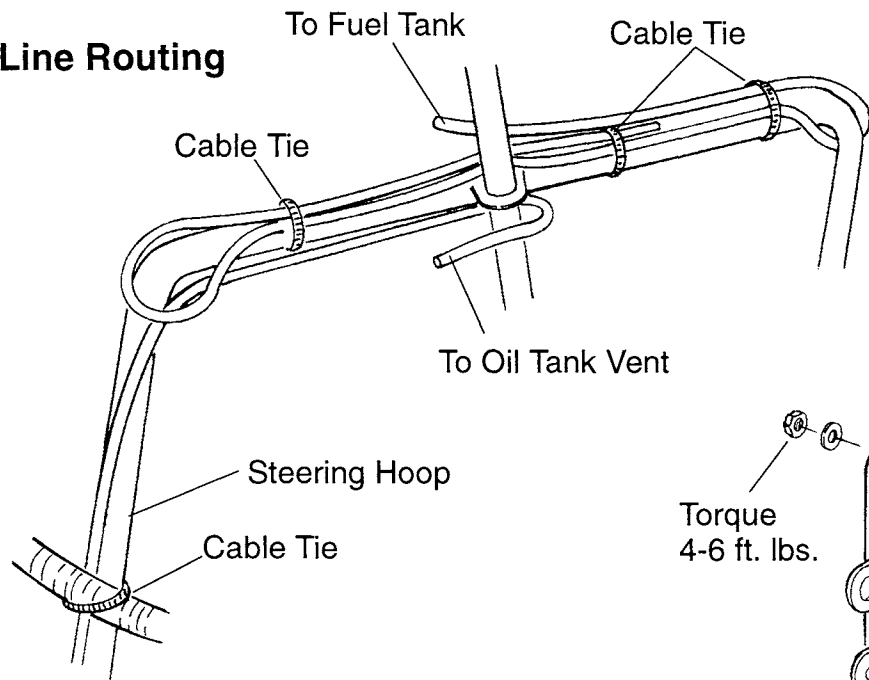

Coolant Bottle & Hose

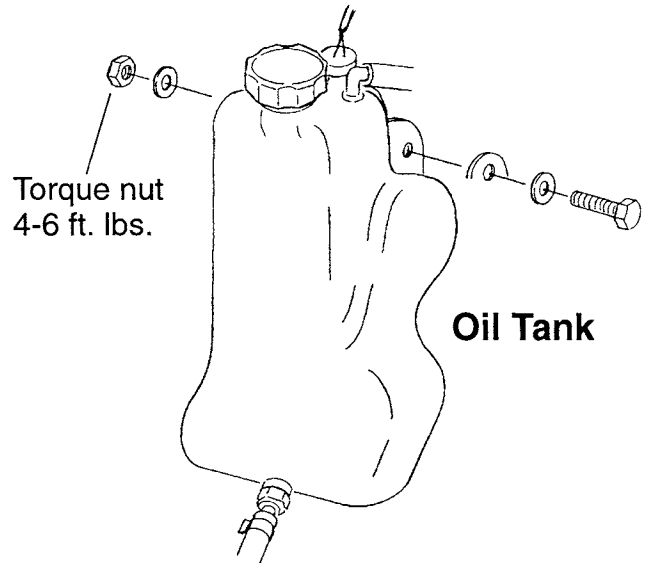
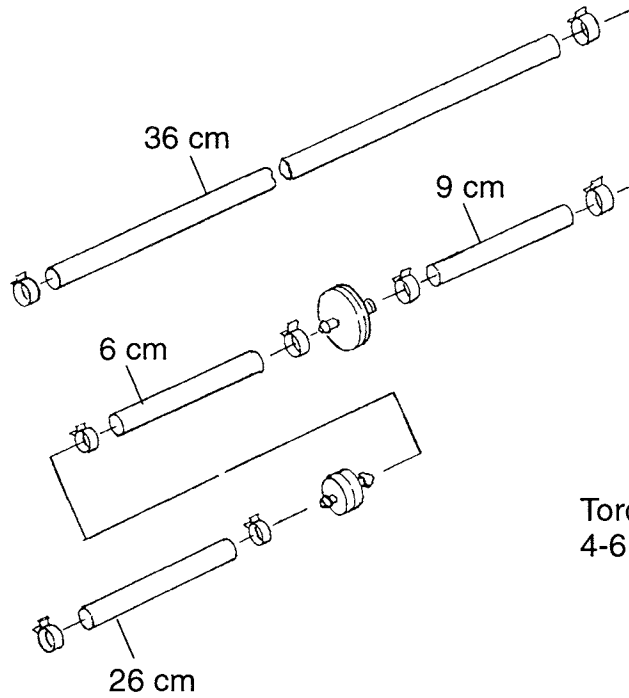

Oil Tank

MAINTENANCE/TUNE UP

Wire Harness and Speedometer Cable Routing - XLT Classic, XLT Touring

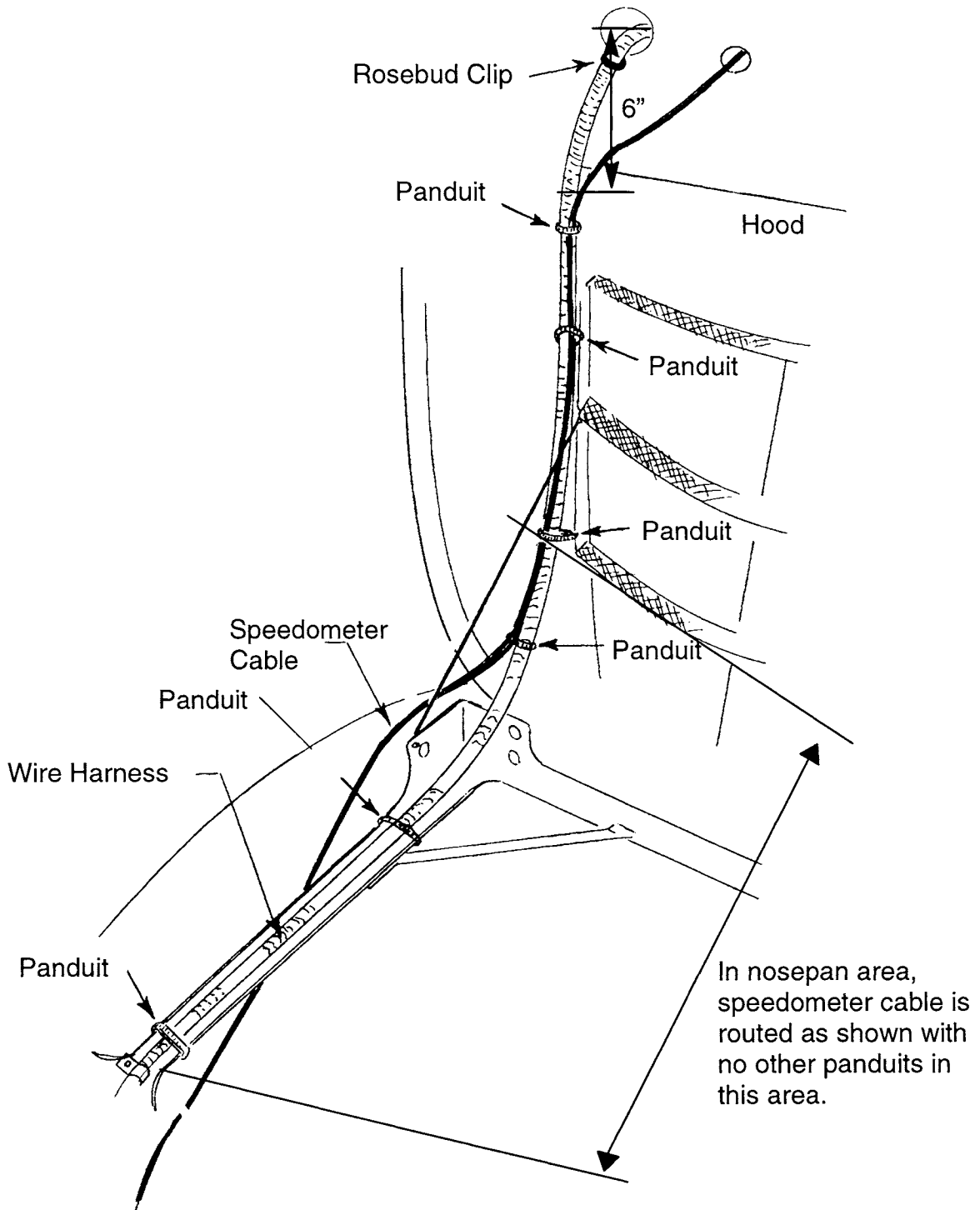

MAINTENANCE/TUNE UP
Fuel Pump and Fuel Line Routing - XLT Classic, XLT Touring

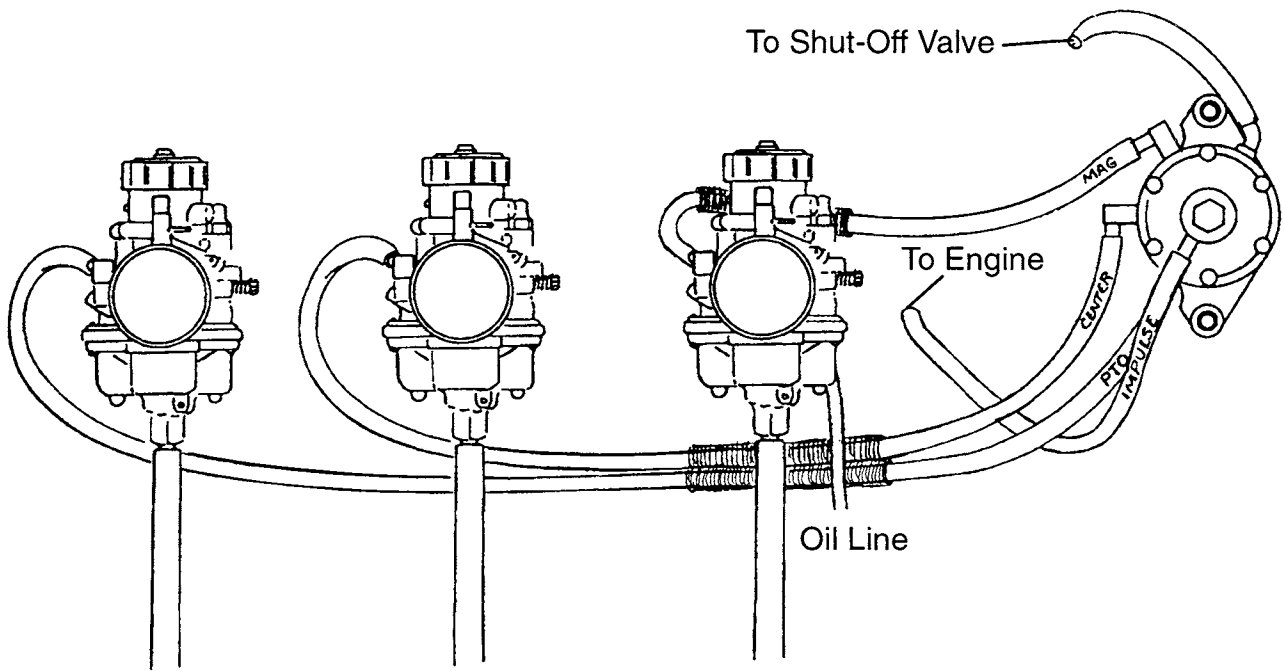

MAINTENANCE/TUNE UP
Backrest - Classic Touring, XLT Touring

Leave cable on rear outside portion of backrest adjuster so it doesn't get pinched when backrest is put down on seat for shipping

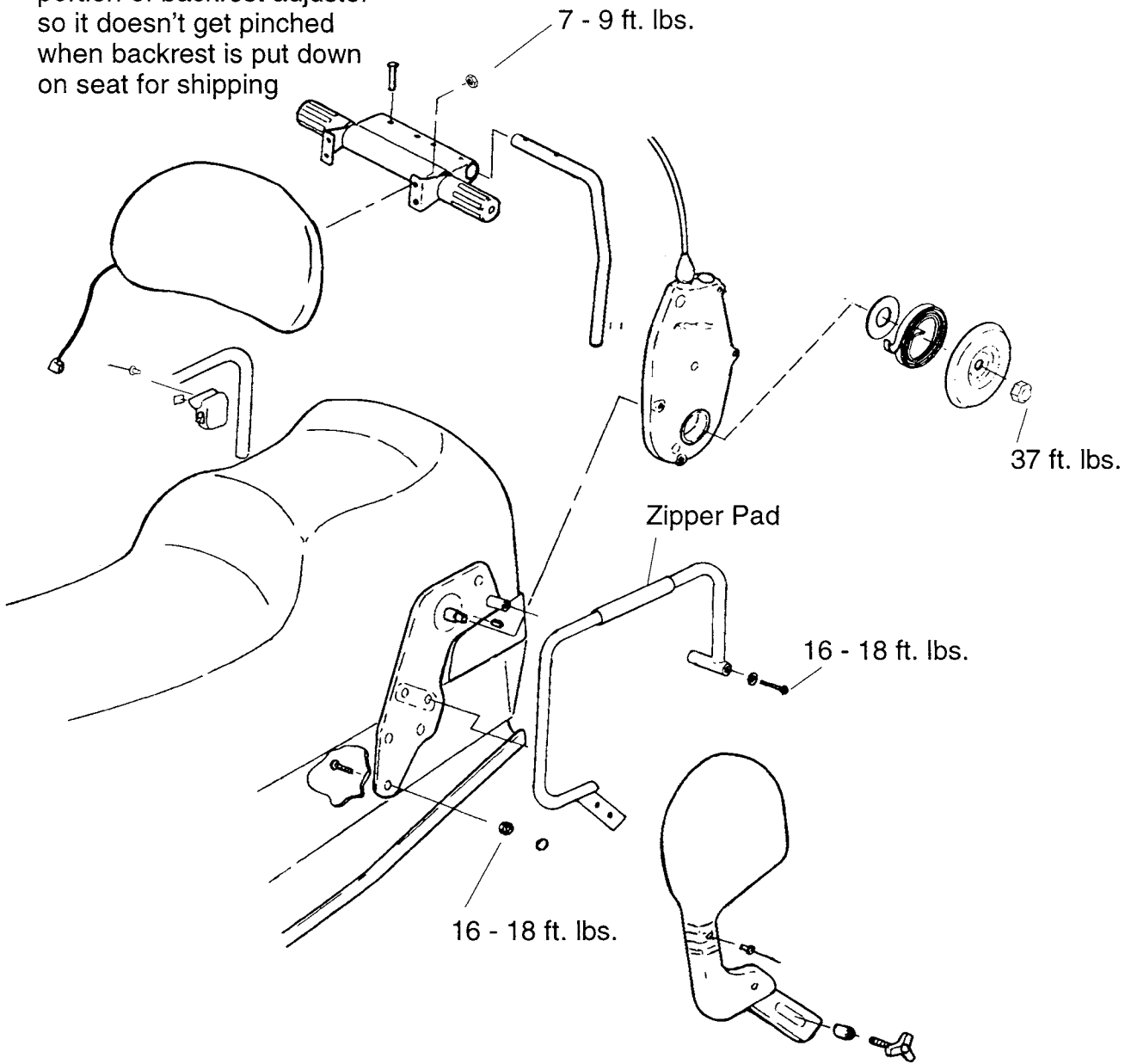

MAINTENANCE/TUNE UP
Handle Grip Heater Wire Routing - Classic Touring, XLT Touring

Zipper Position

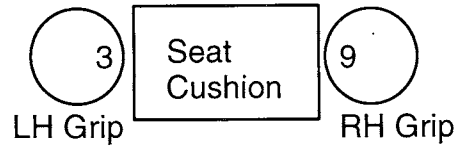

Locate center of grip heater.
Position 1" forward from
center of handgrip with
zipper toward seat cushion.
Cut and remove zipper tab.

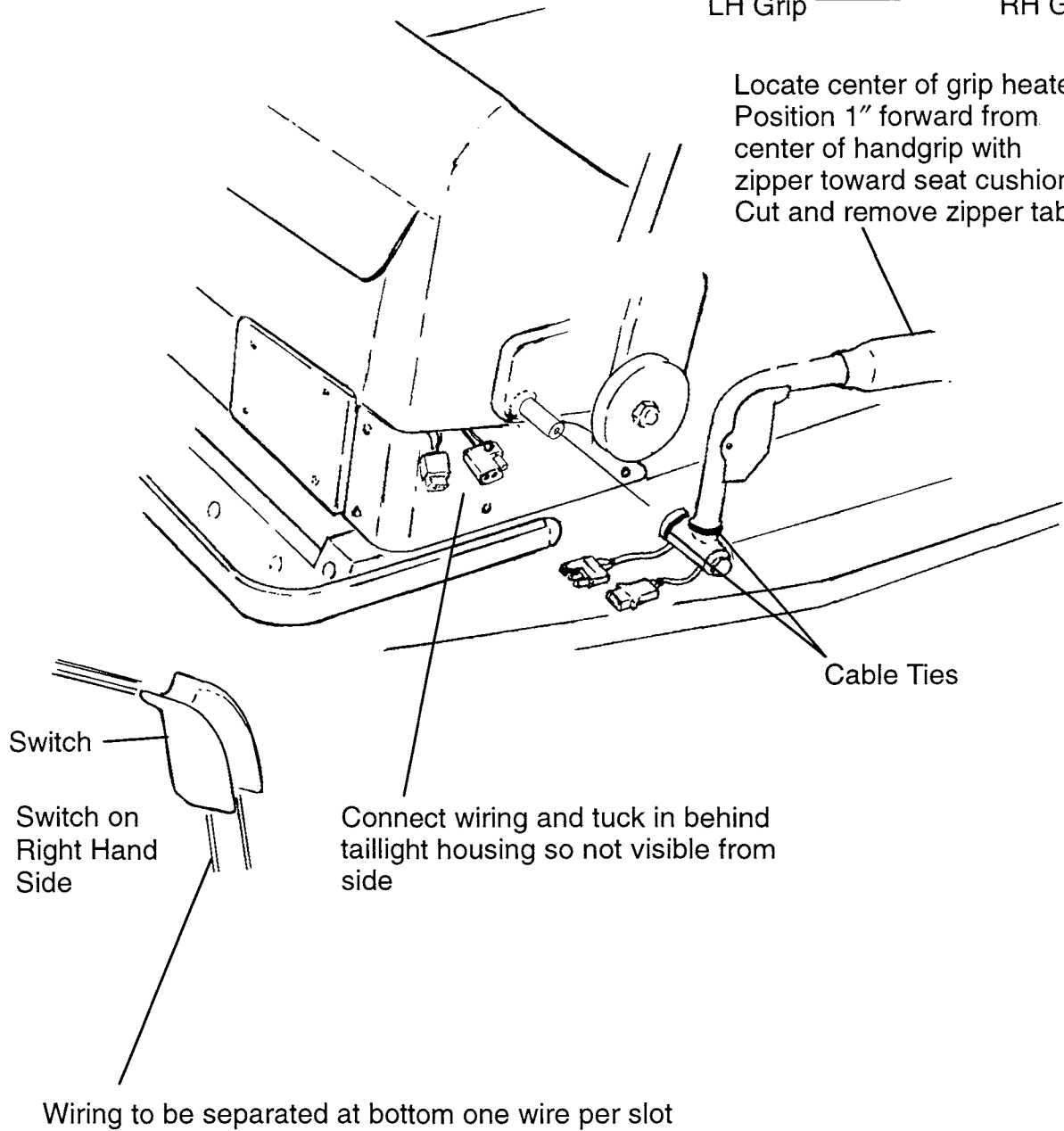

Wiring to be separated at bottom one wire per slot

MAINTENANCE/TUNE UP

Fuel Tank and Coolant Bottle Vent Line Routing, 440 XCR, 500 XC/SP, 600 XC/SP, 700 XC/SP

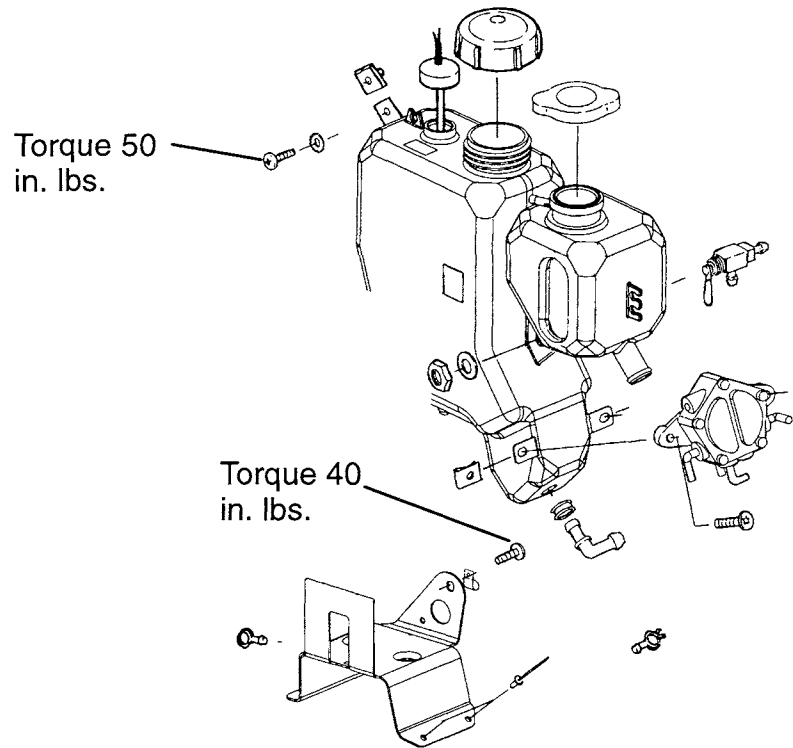
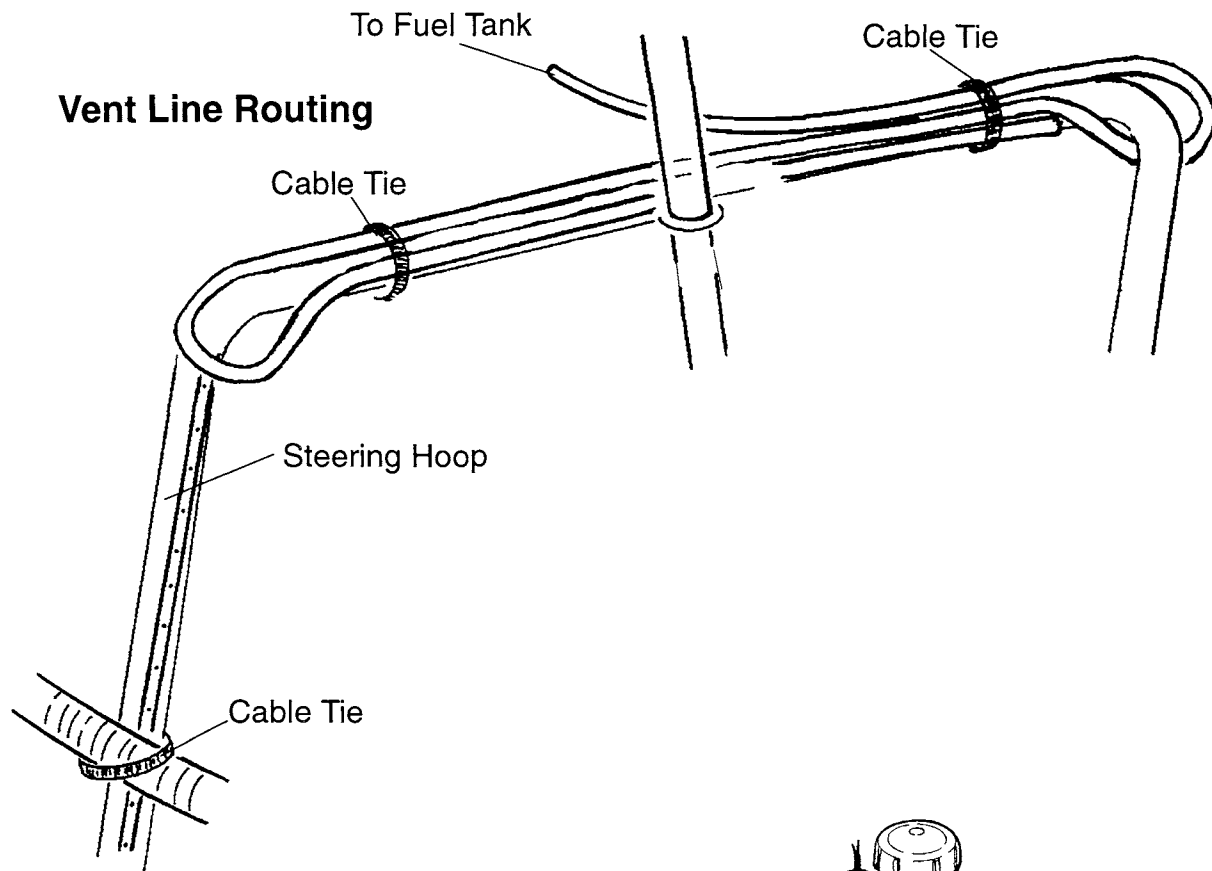

MAINTENANCE/TUNE UP
Fuel Tank and Coolant Bottle Vent Line Routing - 700 XCR, 800 XCR

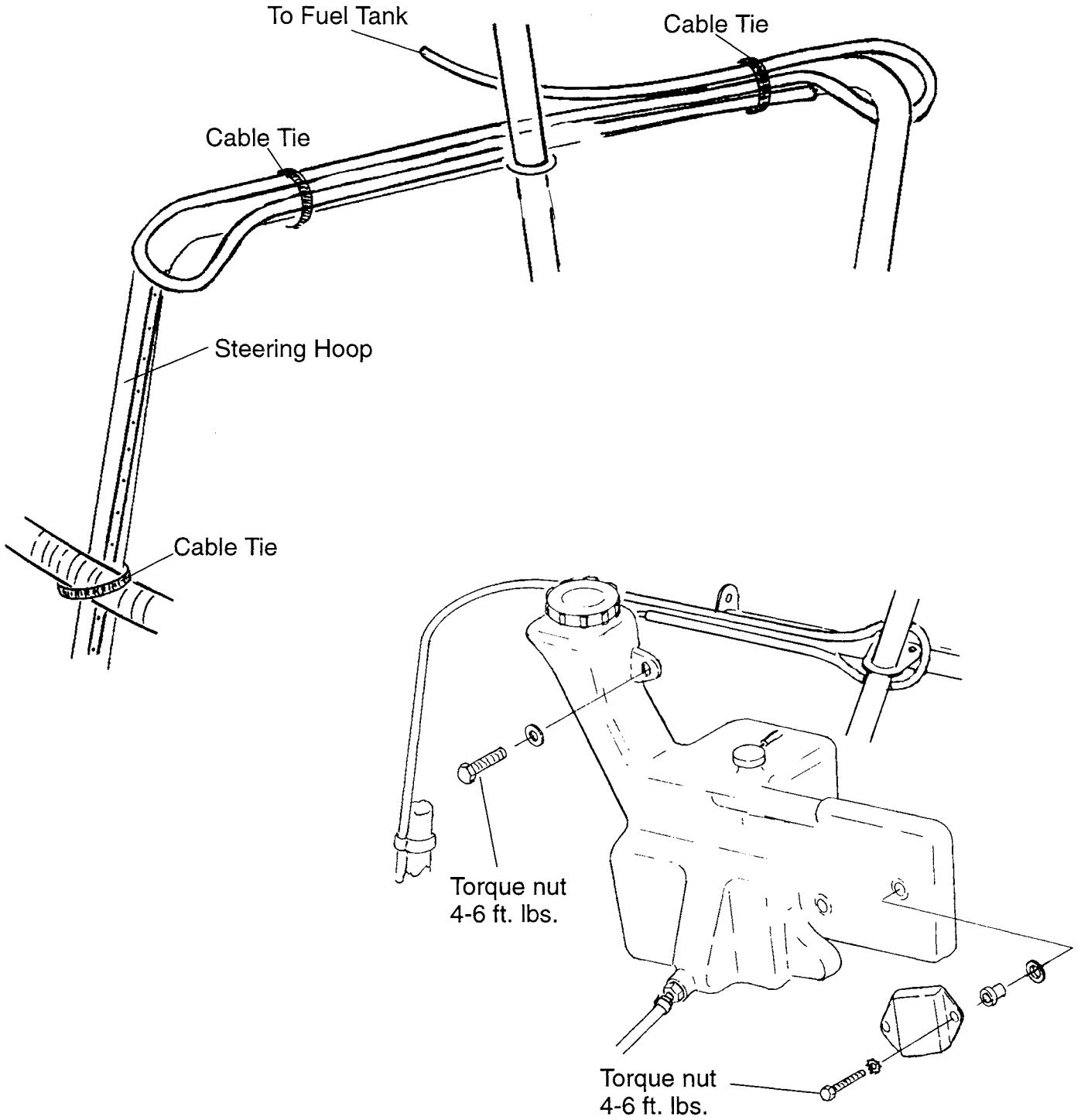

MAINTENANCE/TUNE UP
Fuel Tank/Oil Tank Vent Line Routing - Trail RMK

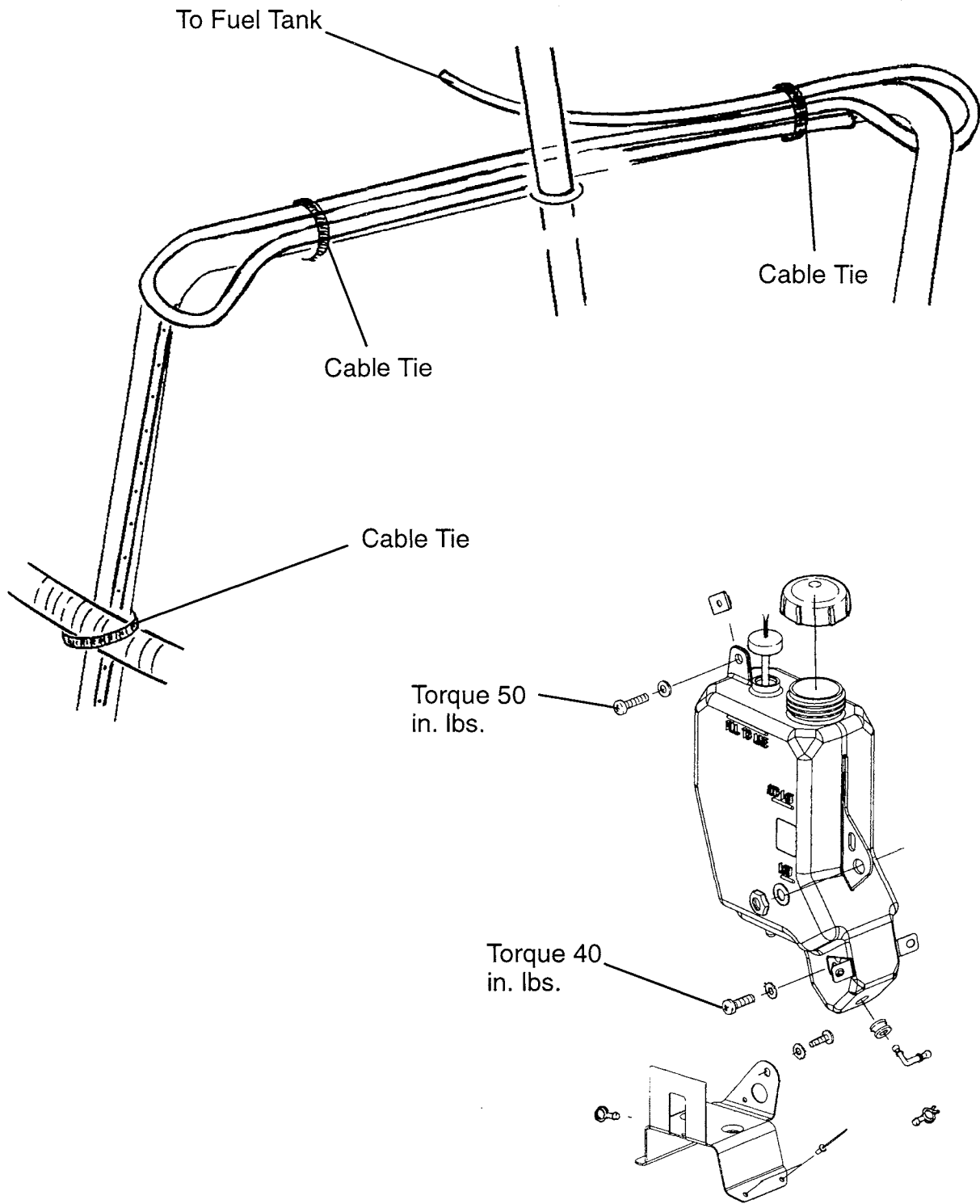

**MAINTENANCE/TUNE UP
ACCS System - Trail RMK**

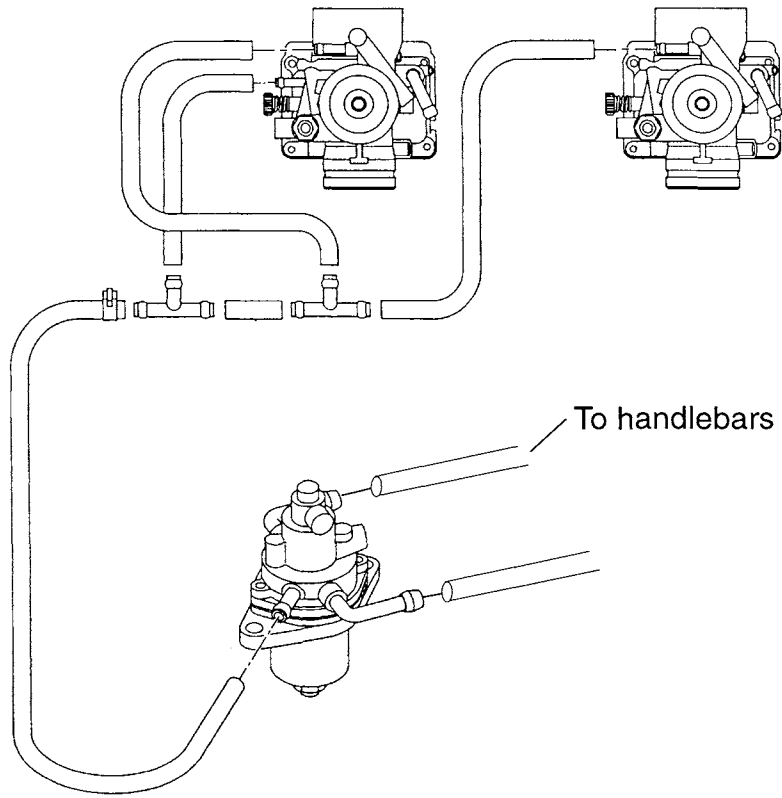

MAINTENANCE/TUNE UP
Fuel Tank / Oil Tank Vent Line Routing - 500 RMK

Vent Line Routing

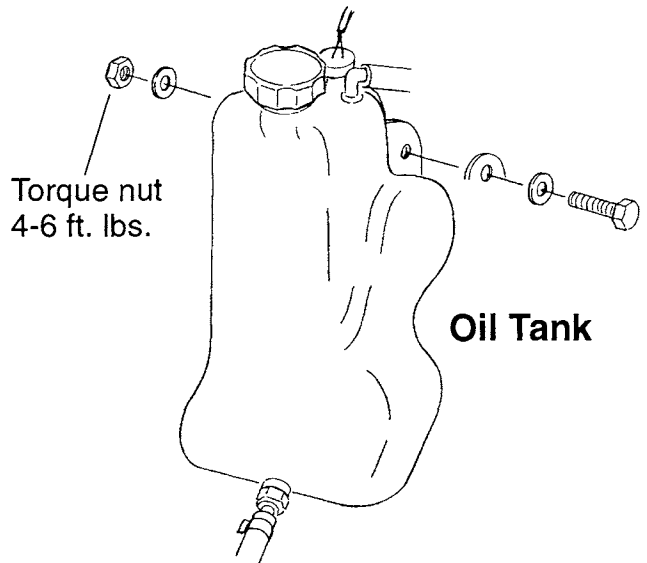
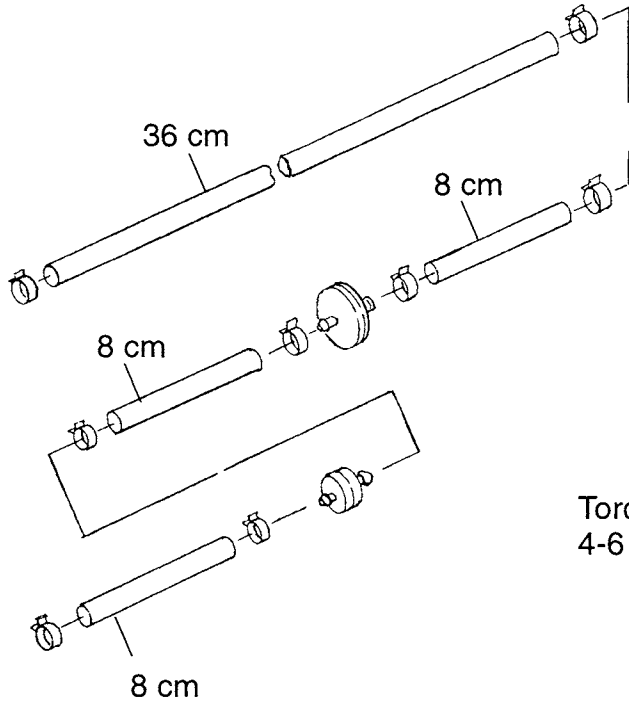
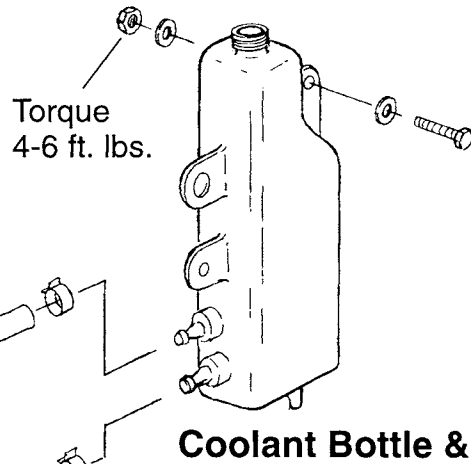
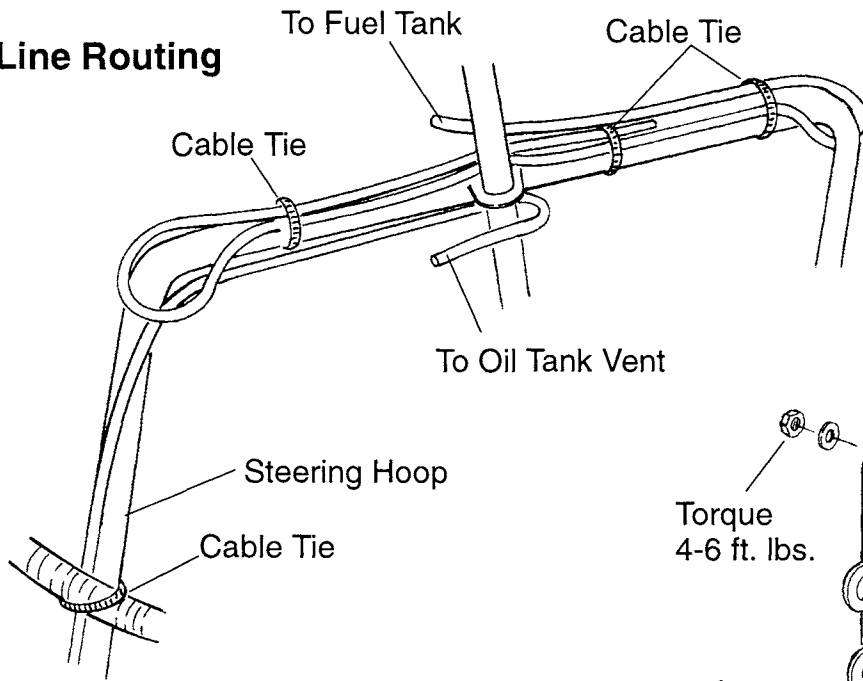

MAINTENANCE/TUNE UP
Wire Harness and Speedometer Cable Routing - 500 RMK

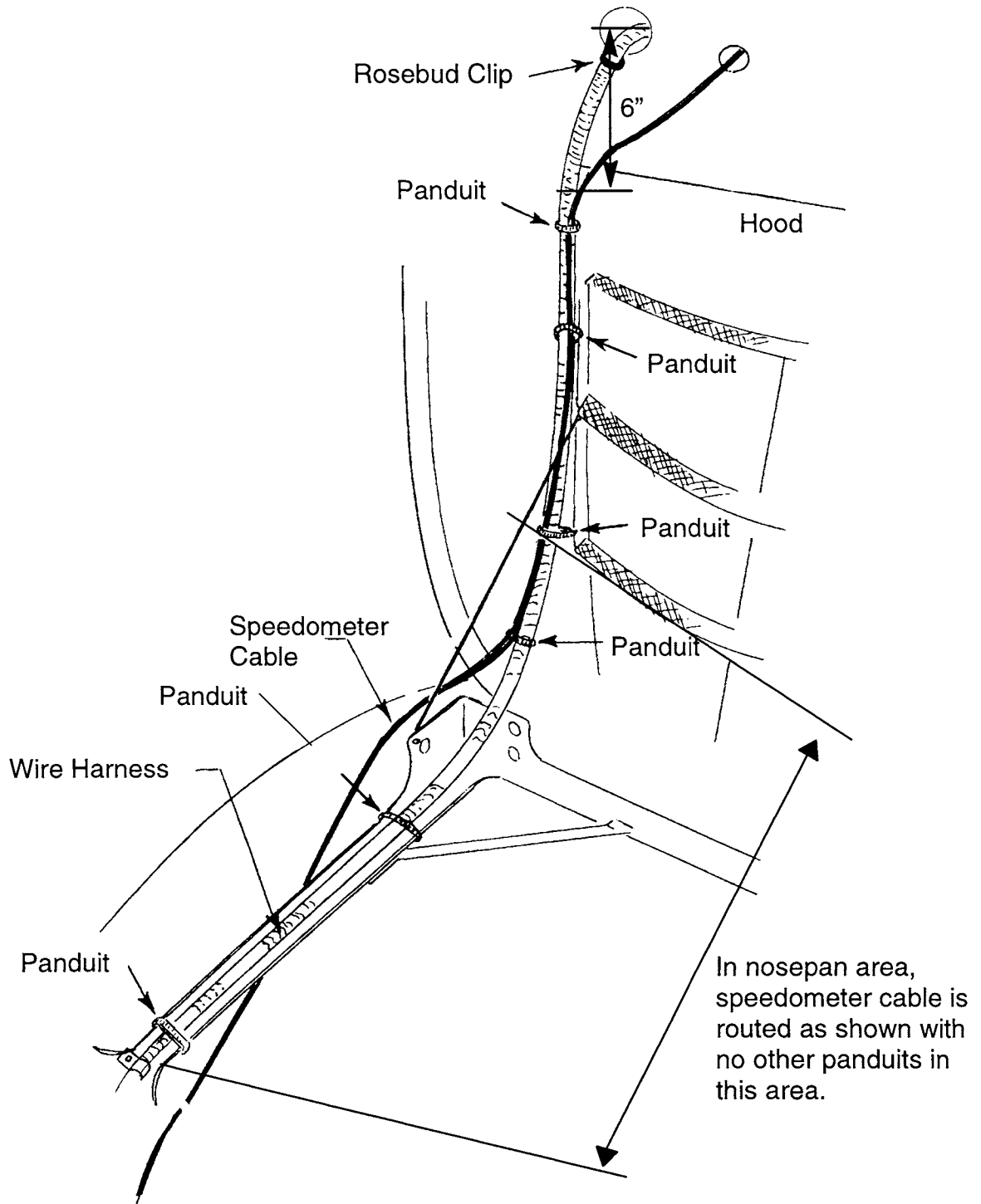

MAINTENANCE/TUNE UP
Cooling System - 500 RMK

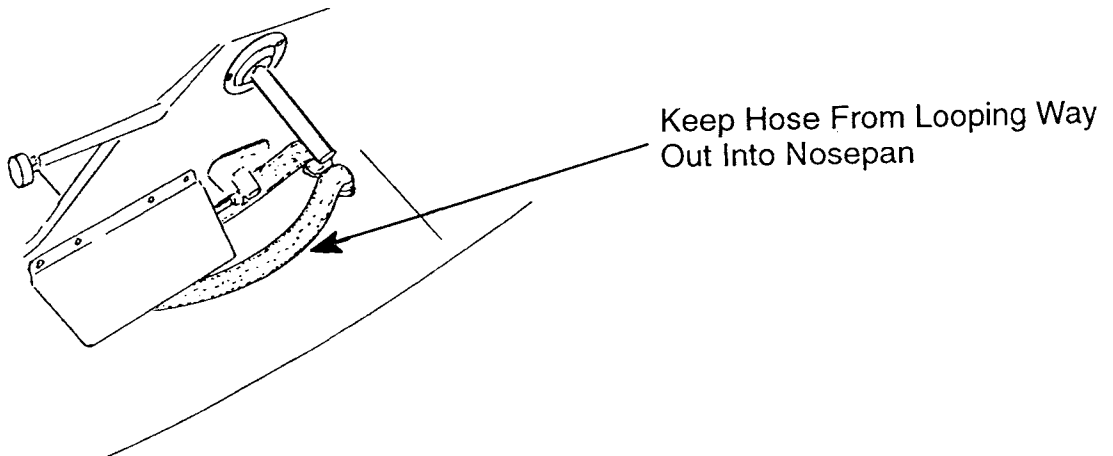
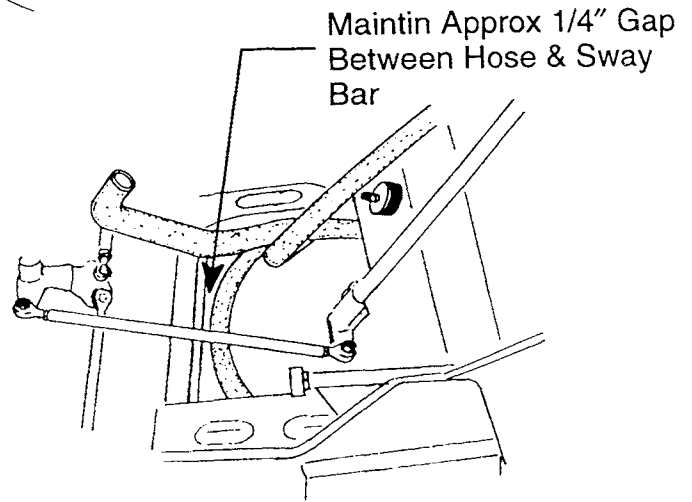
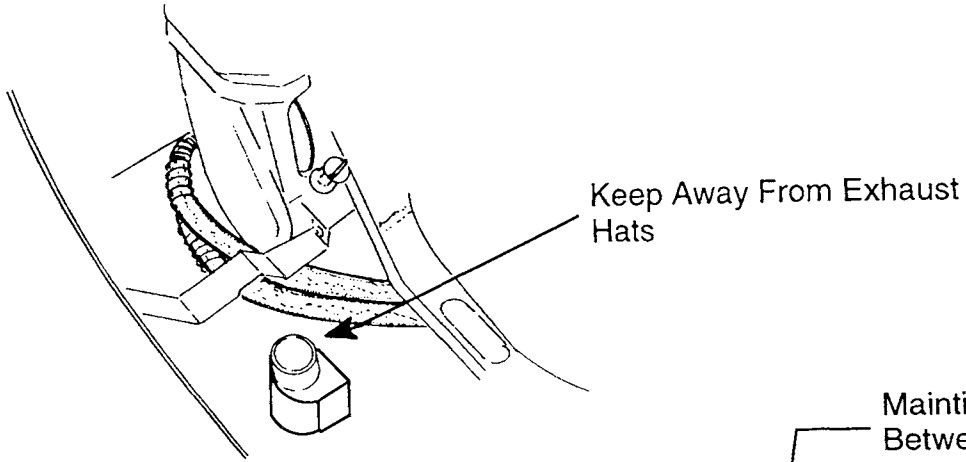

MAINTENANCE/TUNE UP
Fuel Pump and Fuel Line Routing - 500 RMK

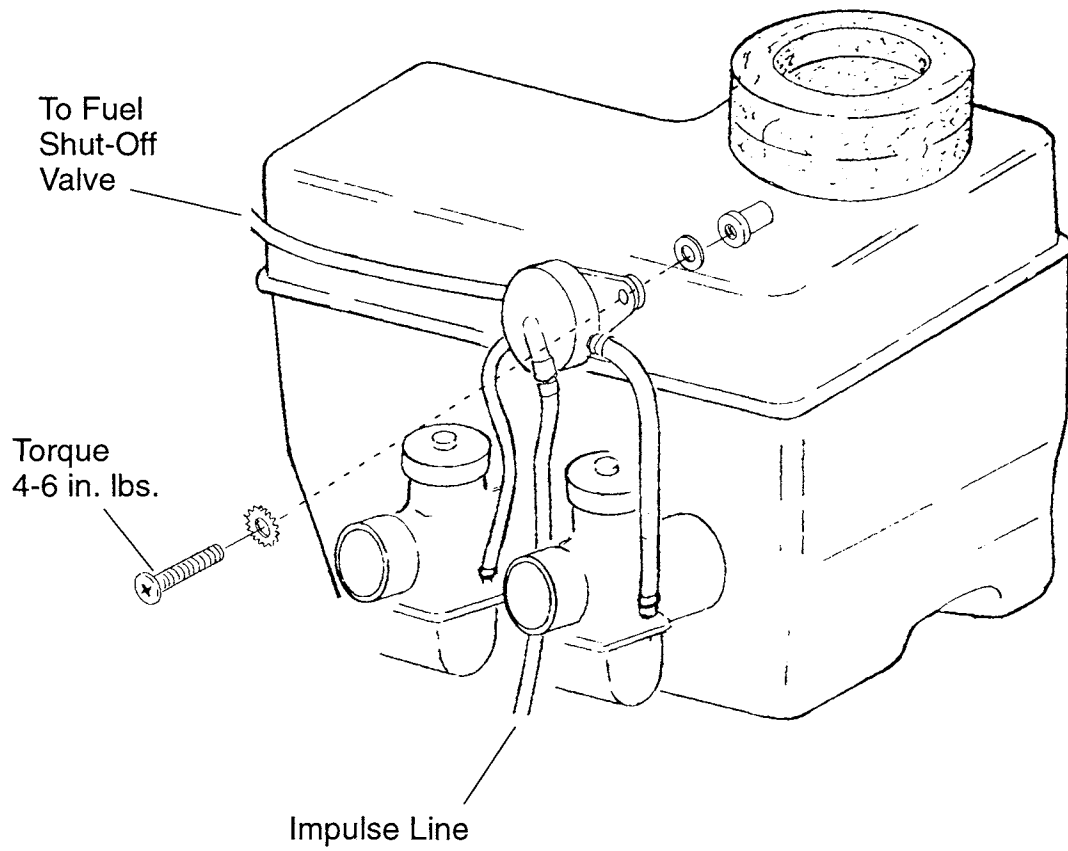

**MAINTENANCE/TUNE UP
ACCS System - 500 RMK**

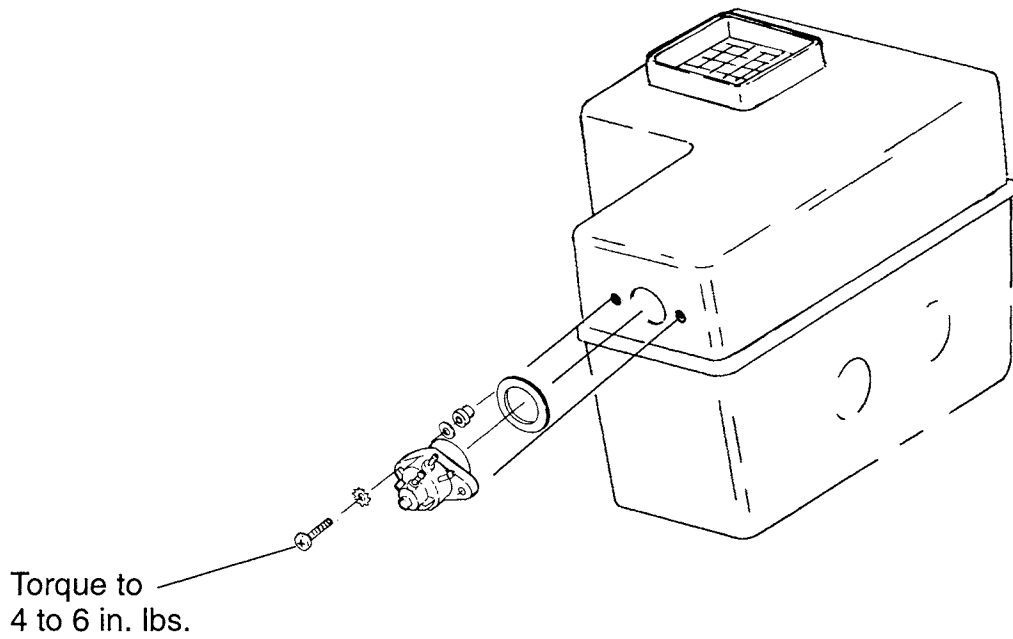
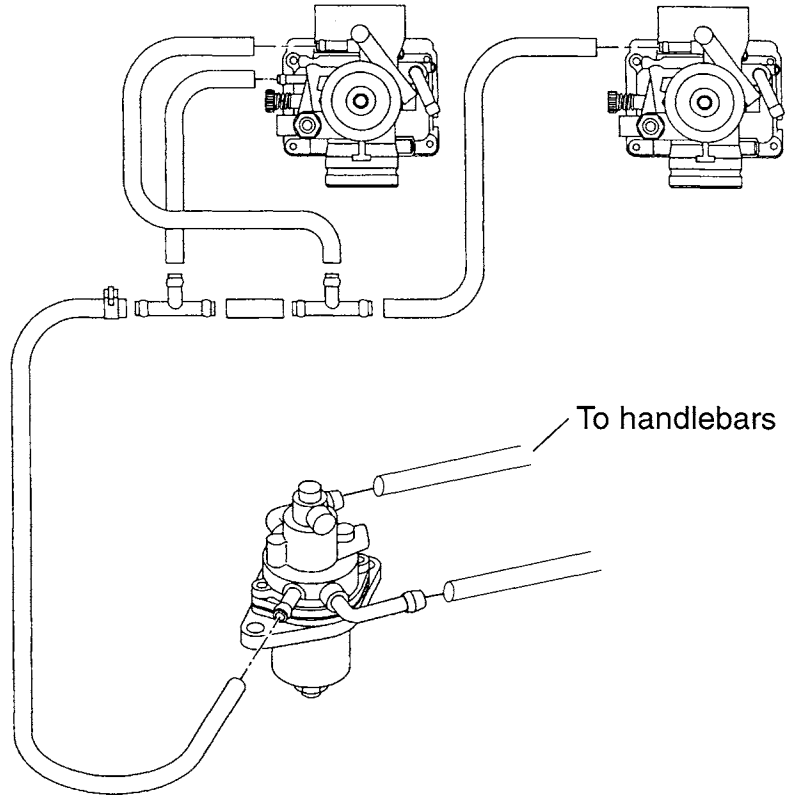

MAINTENANCE/TUNE UP
Fuel Tank and Coolant Bottle Vent Line Routing - 600 RMK, 700 RMK, 700 SKS

