

TLA5000B Series Logic Analyzer Installation Manual

This document supports TLA System Software Version 5.6 and above.

Warning

The servicing instructions are for use by qualified personnel only. To avoid personal injury, do not perform any servicing unless you are qualified to do so. Refer to all safety summaries prior to performing service.

www.tektronix.com

077-2066-02

Tektronix

Copyright © Tektronix. All rights reserved. Licensed software products are owned by Tektronix or its subsidiaries or suppliers, and are protected by national copyright laws and international treaty provisions.

Tektronix products are covered by U.S. and foreign patents, issued and pending. Information in this publication supersedes that in all previously published material. Specifications and price change privileges reserved.

TEKTRONIX and TEK are registered trademarks of Tektronix, Inc.

Tektronix, Tek, MagniVu, and iView are registered trademarks of Tektronix, Inc.

Contacting Tektronix

Tektronix, Inc.
14200 SW Karl Braun Drive
P.O. Box 500
Beaverton, OR 97077
USA

For product information, sales, service, and technical support:

- In North America, call 1-800-833-9200.
- Worldwide, visit www.tektronix.com to find contacts in your area.

Warranty 2

Tektronix warrants that this product will be free from defects in materials and workmanship for a period of one (1) year from the date of shipment. If any such product proves defective during this warranty period, Tektronix, at its option, either will repair the defective product without charge for parts and labor, or will provide a replacement in exchange for the defective product. Parts, modules and replacement products used by Tektronix for warranty work may be new or reconditioned to like new performance. All replaced parts, modules and products become the property of Tektronix.

In order to obtain service under this warranty, Customer must notify Tektronix of the defect before the expiration of the warranty period and make suitable arrangements for the performance of service. Customer shall be responsible for packaging and shipping the defective product to the service center designated by Tektronix, with shipping charges prepaid. Tektronix shall pay for the return of the product to Customer if the shipment is to a location within the country in which the Tektronix service center is located. Customer shall be responsible for paying all shipping charges, duties, taxes, and any other charges for products returned to any other locations.

This warranty shall not apply to any defect, failure or damage caused by improper use or improper or inadequate maintenance and care. Tektronix shall not be obligated to furnish service under this warranty a) to repair damage resulting from attempts by personnel other than Tektronix representatives to install, repair or service the product; b) to repair damage resulting from improper use or connection to incompatible equipment; c) to repair any damage or malfunction caused by the use of non-Tektronix supplies; or d) to service a product that has been modified or integrated with other products when the effect of such modification or integration increases the time or difficulty of servicing the product.

THIS WARRANTY IS GIVEN BY TEKTRONIX WITH RESPECT TO THE PRODUCT IN LIEU OF ANY OTHER WARRANTIES, EXPRESS OR IMPLIED. TEKTRONIX AND ITS VENDORS DISCLAIM ANY IMPLIED WARRANTIES OF MERCHANTABILITY OR FITNESS FOR A PARTICULAR PURPOSE. TEKTRONIX' RESPONSIBILITY TO REPAIR OR REPLACE DEFECTIVE PRODUCTS IS THE SOLE AND EXCLUSIVE REMEDY PROVIDED TO THE CUSTOMER FOR BREACH OF THIS WARRANTY. TEKTRONIX AND ITS VENDORS WILL NOT BE LIABLE FOR ANY INDIRECT, SPECIAL, INCIDENTAL, OR CONSEQUENTIAL DAMAGES IRRESPECTIVE OF WHETHER TEKTRONIX OR THE VENDOR HAS ADVANCE NOTICE OF THE POSSIBILITY OF SUCH DAMAGES.

Warranty 9(b)

Tektronix warrants that the media on which this software product is furnished and the encoding of the programs on the media will be free from defects in materials and workmanship for a period of three (3) months from the date of shipment. If any such medium or encoding proves defective during the warranty period, Tektronix will provide a replacement in exchange for the defective medium. Except as to the media on which this software product is furnished, this software product is provided "as is" without warranty of any kind, either express or implied. Tektronix does not warrant that the functions contained in this software product will meet Customer's requirements or that the operation of the programs will be uninterrupted or error-free.

In order to obtain service under this warranty, Customer must notify Tektronix of the defect before the expiration of the warranty period. If Tektronix is unable to provide a replacement that is free from defects in materials and workmanship within a reasonable time thereafter, Customer may terminate the license for this software product and return this software product and any associated materials for credit or refund.

THIS WARRANTY IS GIVEN BY TEKTRONIX WITH RESPECT TO THE PRODUCT IN LIEU OF ANY OTHER WARRANTIES, EXPRESS OR IMPLIED. TEKTRONIX AND ITS VENDORS DISCLAIM ANY IMPLIED WARRANTIES OF MERCHANTABILITY OR FITNESS FOR A PARTICULAR PURPOSE. TEKTRONIX' RESPONSIBILITY TO REPLACE DEFECTIVE MEDIA OR REFUND CUSTOMER'S PAYMENT IS THE SOLE AND EXCLUSIVE REMEDY PROVIDED TO THE CUSTOMER FOR BREACH OF THIS WARRANTY. TEKTRONIX AND ITS VENDORS WILL NOT BE LIABLE FOR ANY INDIRECT, SPECIAL, INCIDENTAL, OR CONSEQUENTIAL DAMAGES IRRESPECTIVE OF WHETHER TEKTRONIX OR THE VENDOR HAS ADVANCE NOTICE OF THE POSSIBILITY OF SUCH DAMAGES.

Table of Contents

Service Safety Summary	iii
Preface	iv
TLA5000B Series Logic Analyzers	iv
Documentation	v
Basic Installation	1
Check the Shipping List.....	1
Site Considerations	1
Chassis Ground Connections	3
Connecting Accessories.....	4
Connecting Probes.....	5
First Time Operation	6
Creating Operating System Restore Discs	8
Performing the Incoming Inspection	9
Backing Up User Files	9
Connecting Probes to the Target System	9
Additional Information.....	9
Product Overview	11
Front Panel Controls.....	11
External Connectors	11
Restoring and Installing Software	13
Restoring the Instrument Operating System	13
Change the BIOS Settings	16
Reinstalling the TLA Application Software	16
Upgrading or Restoring Firmware	19
Appendix A: User Service Procedures	21
General Care	21
Self Calibration	21
Preventive Maintenance.....	21
In Case of Problems	22
Repacking for Shipment	25
Appendix B: Accessories and Options	27
Standard Accessories.....	27
Optional Accessories	27
Options.....	27
Index	

List of Figures

Figure i: TLA5000B series logic analyzer.....	v
Figure 1: Location of the ground connection.....	3
Figure 2: Accessory connections	4
Figure 3: Connecting the P64xx logic analyzer probes	6
Figure 4: Power cord connector location	7
Figure 5: Logic analyzer front panel	11

List of Tables

Table 1: Environmental characteristics	1
Table 2: Power considerations	2
Table 3: Accessory connection information	5
Table 4: Failure symptoms and possible causes.....	24

Service Safety Summary

Only qualified personnel should perform service procedures. Read this *Service Safety Summary* and the *General Safety Summary* before performing any service procedures. The *General Safety Summary* can be found in the *Tektronix Logic Analyzer Family Product Safety & Compliance Instructions* (Tektronix part number 071-2591-xx).

Do Not Service Alone. Do not perform internal service or adjustments of this product unless another person capable of rendering first aid and resuscitation is present.

Disconnect Power. To avoid electric shock, switch off the instrument power, then disconnect the power cord from the mains power.

Use Care When Servicing With Power On. Dangerous voltages or currents may exist in this product. Disconnect power, remove battery (if applicable), and disconnect test leads before removing protective panels, soldering, or replacing components.

To avoid electric shock, do not touch exposed connections.

Preface

This manual contains all information needed to install your Tektronix logic analyzer and related accessories.

To prevent personal injury or damage, consider the following requirements before starting service:

- The procedures in this manual should be performed only by qualified service personnel.
- Read the *General Safety Summary* and *Service Safety Summary* found in the *Tektronix Logic Analyzer Family Product Safety & Compliance Instructions* (Tektronix part number 071-2591-xx).

Be sure to follow all warnings, cautions, and notes in this manual.

TLA5000B Series Logic Analyzers

The TLA5000B series logic analyzers consist of portable logic analyzer mainframes, which differ by channel width, and all of the accessories and supports that are used with them. The logic analyzers are built on the Microsoft Windows operating system, which allows you to install any PC-compatible, third-party hardware and software on the instrument.

Because the instrument can operate in a network environment, Microsoft recommends the following:

- Use an Internet firewall.
- Install operating system updates regularly.
- Use up-to-date antivirus software.

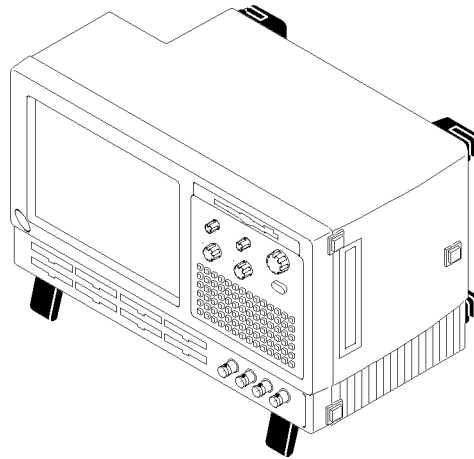
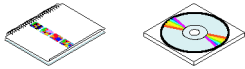

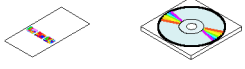
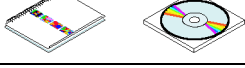





Figure i: TLA5000B series logic analyzer





Documentation

The following table lists related documentation available for your logic analyzer. The documentation is available on the TLA Documentation CD and on the Tektronix Web site (www.tektronix.com/manuals).

Related Documentation

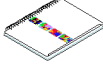
Item	Purpose	Location
TLA Quick Start User Manuals	High-level operational overview	
Online Help	In-depth operation and UI help	
Installation Quick Reference Cards	High-level installation information	
Installation Manuals	Detailed first-time installation information	
XYZs of Logic Analyzers	Logic analyzer basics	 www.Tektronix.com
Declassification and Security instructions	Data security concerns specific to sanitizing or removing memory devices from Tektronix products	 www.Tektronix.com
Application notes	Collection of logic analyzer application specific notes	
Product Specifications & Performance Verification Procedures	TLA Product specifications and performance verification procedures	

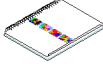
Related Documentation (cont.)

Item	Purpose	Location
TPI.NET Documentation	Detailed information for controlling the logic analyzer using .NET	
Field upgrade kits	Upgrade information for your logic analyzer	 
Optional Service Manuals	Self-service documentation for modules and mainframes	 

Basic Installation

This chapter describes all of the steps needed to install your Tektronix logic analyzer and its related accessories.

Check the Shipping List

Check that you have received all of the parts of your logic analyzer using the shipping list. Also check the following:

- That you have the correct power cords for your geographical area.
- That you have backup copies of the installed software. Store the backup software in a safe location where you can easily retrieve the software for maintenance.
- That you have all the standard and optional accessories that you ordered.

Fill out and return the customer registration card that is packaged with this manual.

Site Considerations

Read this section before installing the logic analyzer. This section describes site considerations, power requirements, and ground connections for your logic analyzer.

Table 1: Environmental characteristics

Feature	Description
Temperature	<i>Operating (no media in drive)</i> +5 °C to +50 °C, 15 °C/hr maximum gradient, noncondensing (derated 1 °C per 305 m (1000 ft) above 1524 m (5000 ft) altitude)
	<i>Nonoperating (no media in drive)</i> -20 °C to +60 °C, 15 °C/hr maximum gradient, noncondensing
Humidity	<i>Operating (no media in drive)</i> 20% to 80% relative humidity, noncondensing. Maximum wet bulb temperature: +29 °C (derates relative humidity to approximately 22% at +50 °C).
	<i>Nonoperating (no media in drive)</i> 8% to 80% relative humidity, noncondensing. Maximum wet bulb temperature: +29 °C (derates relative humidity to approximately 22% at +50 °C).

Table 1: Environmental characteristics (cont.)

Feature	Description
Altitude	<i>Operating</i>
	To 3000 m (9843 ft), (derated 1 °C per 305 m (1000 ft) above 1524 m (5000 ft) altitude.
	<i>Nonoperating</i>
	12,190 m (40,000 ft)



CAUTION. *Allow a 5.1 cm (2 in) clearance around the top, back, and sides of the instrument to ensure proper cooling. Inadequate clearances can cause the instrument to overheat and shut down.*

Table 2: Power considerations

Feature	Description
Source Voltage and Frequency	100 V _{RMS} to 240 V _{RMS} ±10%, 47 Hz to 63 Hz
Maximum Power Consumption	240 Watts line power maximum
Steady-State Input Current	4 A _{RMS} maximum

You can use the logic analyzer on a bench or on a cart in the normal position (on the bottom feet).

Chassis Ground Connections

Use the chassis ground connections to connect the grounds of the target system (system-under-test) to the logic analyzer to ensure a common ground connection between instruments. (See Figure 1.)

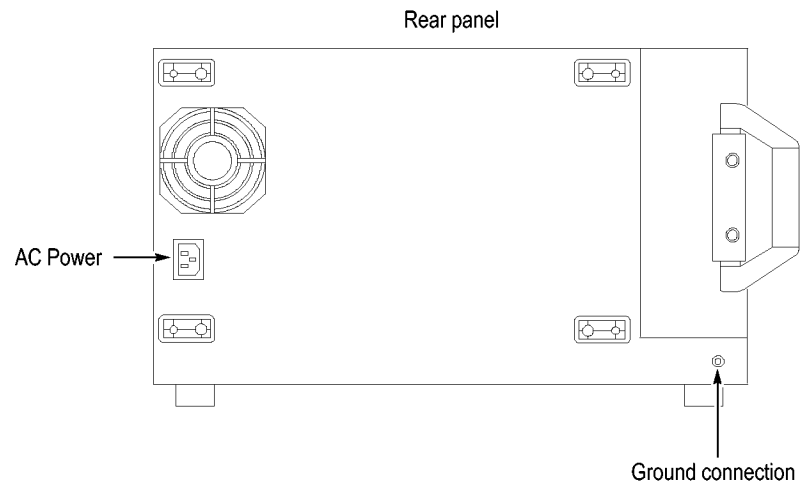

Figure 1: Location of the ground connection

Connecting Accessories

After installing the mainframe, you can connect accessories such as an external monitor, keyboard, and printer. Connect the accessories to the side of the instrument; depending on your model, the number of connectors and locations may differ. (See Figure 2.)

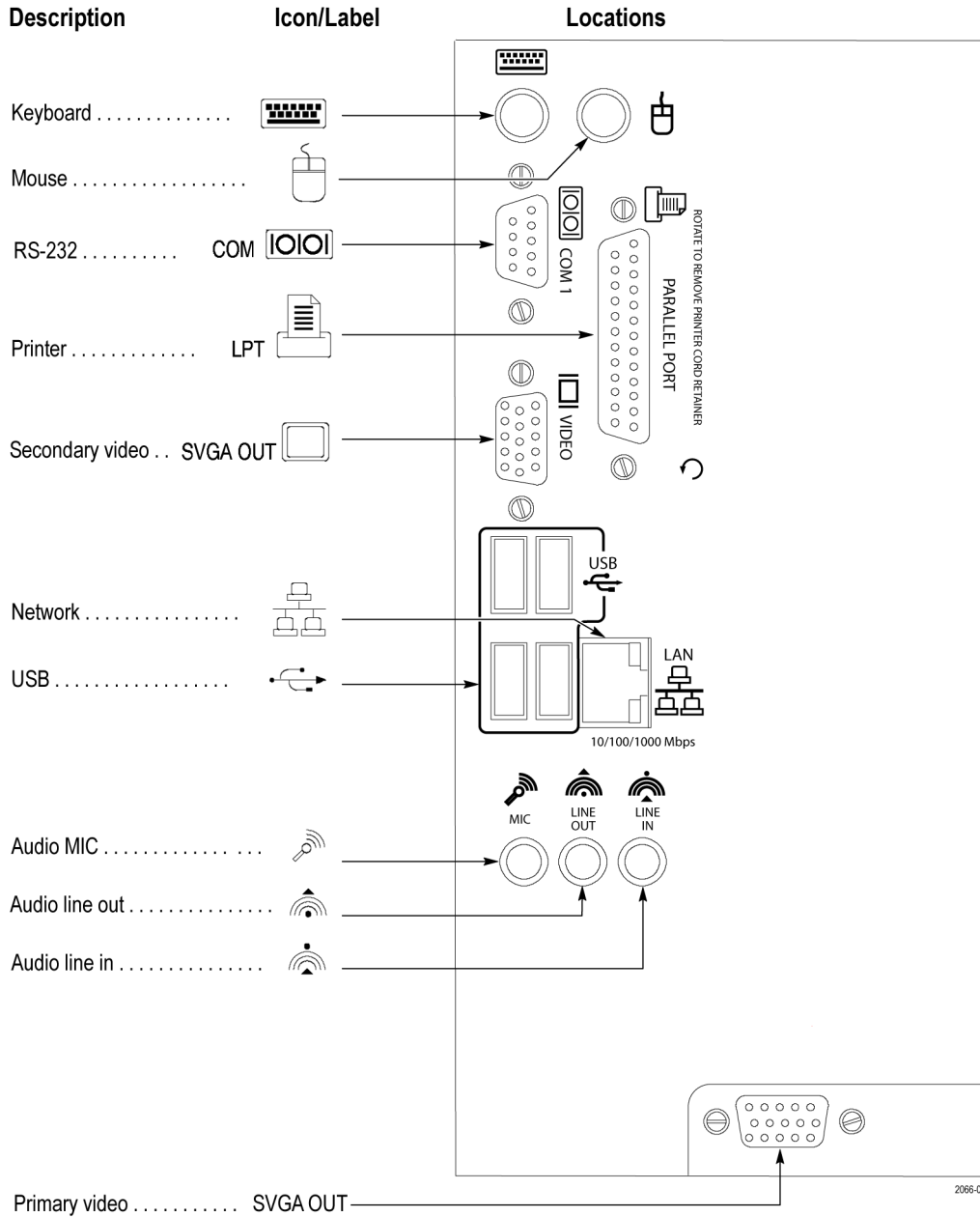

Figure 2: Accessory connections

Table 3: Accessory connection information

Item	Description
Monitor	If you use a non-plug & play monitor, you may need to change the Windows display settings to achieve the proper resolution.
Printer	Connect the printer to the LPT (parallel) port.
Rackmount	The logic analyzer can be installed in rackmount kits. Refer to the respective rackmount kit instructions for installation information.

Connecting Probes

After you have connected all the accessories, you can connect the probes to the instrument. Refer to the appropriate section for your instrument.

For additional information on the individual probes, refer to the instructions that accompanied your probes.



CAUTION. *When attaching the probe to the logic analyzer, you must use care to tighten probe screws evenly until they are snug. First slightly tighten screws, then snug each screw to 4 in-lbs (max). Undertightening the probe screws can result in intermittent performance. Over tightening can result in stripped screws.*

Connect the logic analyzer probes and the optional retaining brackets as shown. (See Figure 3.)

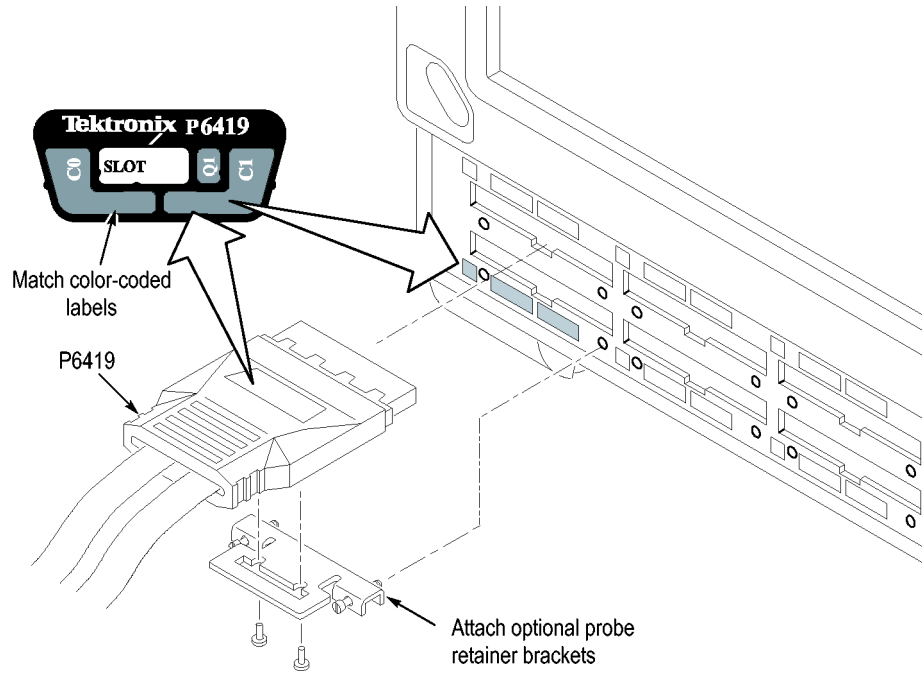

Figure 3: Connecting the P64xx logic analyzer probes

First Time Operation



CAUTION. *Connect the keyboard, mouse, and other accessories before applying power to the logic analyzer. Connecting the accessories after turning on the logic analyzer can damage the accessories.*

Follow these steps to turn on the logic analyzer for the first time:

1. Connect the power cord. (See Figure 4.)
2. If you have an external monitor, connect the power cord and turn on the monitor.

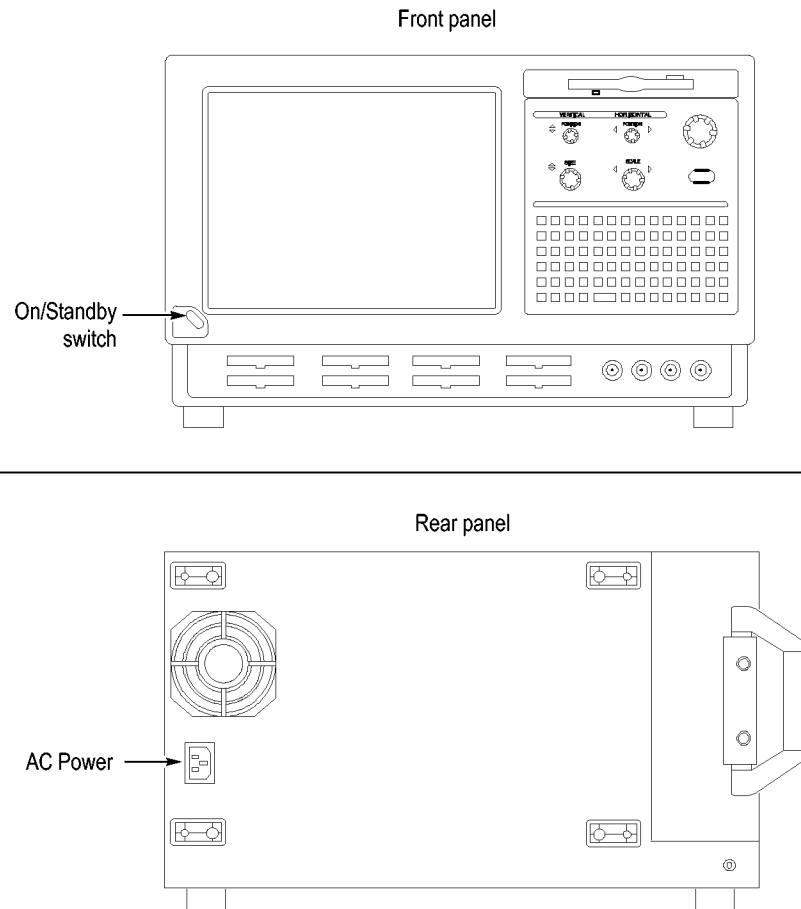

Figure 4: Power cord connector location

3. Turn on the logic analyzer as follows:
 - a. Press the On/Standby switch on the front of the instrument to turn on the logic analyzer. (See Figure 4.)
 - b. Wait for the logic analyzer to complete power-on self-tests and start Windows.

Creating Operating System Restore Discs

The instrument does not ship with an operating system restore disc. Use the following procedure to create a set of discs that enable you to restore the operating system if the need arises.

Creating Restore Discs with an External DVD-RW Drive

Tektronix recommends using an external DVD-RW drive to create the operating system restore discs because the TLA5000B CD/DVD drive cannot write DVDs.

NOTE. *If you do not have an external DVD-RW drive, use the procedure to create the disk image files (*.iso) on the instrument hard disk drive. Copy the image file using a USB flash drive (8 GB minimum) or perform a file transfer over a network to an external PC with a DVD-RW drive. Then, use the external PC to create the restore discs.*

Creating the Restore Discs

This procedure creates a set of restore discs for the Microsoft Windows operating system. After restoring the operating system, use the TLA Application disc to reinstall the TLA application software. (See page 16, *Reinstalling the TLA Application Software*.) You will need blank discs (one for each backup file).

1. Insert a blank disc in the DVD drive.
2. Click Start > All Programs > Nero 8 > Data > Nero Express Essentials.
3. Click Image, Project, Copy.
4. Click Disk Image or Saved Project.
5. Navigate to C:\backup.
6. Select file backup1 and click Open.
7. Click the Verify data on disk after burning check box to enable this function.
8. Click the Burn button. The application writes the backup file to the disc and then verifies that the data matches the source file.
9. When the application reports that the write process has completed successfully, remove the disc and label it appropriately (include backup file name, instrument name, instrument serial number, and date).
10. Copy the disk image files (*.iso) located in the C:\backup directory to a network location, a separate hard disk, or optical media for backup purposes.
11. Store the backup discs as defined by your company policy.

NOTE. *You can only use restore discs on the instrument that created them.*

Performing the Incoming Inspection

Incoming inspection consists of verifying the basic operation of the logic analyzer. The power-on diagnostics check the basic functionality. The diagnostics run every time you turn on the logic analyzer.

You can also verify more detailed functionality by running the self-calibration and extended diagnostics.

NOTE. Allow the mainframe to warm up for 30 minutes before running the self-calibration.

To run self-calibration and diagnostics, perform the following:

1. Disconnect any probes that are attached to the input connectors.
2. From the System menu, select Calibration and Diagnostics.
3. Run the self-calibration, and then run the extended diagnostics by selecting the proper tab. Results of the tests display on the individual property pages.

Checking the Logic Analyzer Probes (Optional)

Connect the logic analyzer probes to a signal source and (if necessary) adjust the threshold levels for the probes to acquire the signals. Use the threshold and activity indicators in the LA Setup window to verify signal activity at the probe tips.

Backing Up User Files

Back up your user files regularly. Use the Windows back up tools or copy the files to another media. Always keep a backup copy of files that you access regularly.

Connecting Probes to the Target System

The logic analyzer connects to the target system through probes. The logic analyzer probes allow you to connect to the target system in several different ways. For probe-specific connection details, refer to the appropriate probe instruction manual or browse the Tektronix Web site.

Additional Information

For detailed information on using the logic analyzer refer to the TLA online help.

Release Notes. To access the Logic Analyzer Release Notes, click Start > Programs > Tektronix Logic Analyzer > TLA Release Notes.

Product Overview

This chapter briefly describes the product controls and connectors of the logic analyzers. Refer to the online help for detailed operating information for the logic analyzers.

Front Panel Controls

You can use the front panel controls to operate the logic analyzer. You can also attach an external keyboard, monitor, and mouse to operate the logic analyzer.

You can use the front panel keys as an alternative to an external keyboard. Most keys and key combinations are available using the front panel. (See Figure 5.)

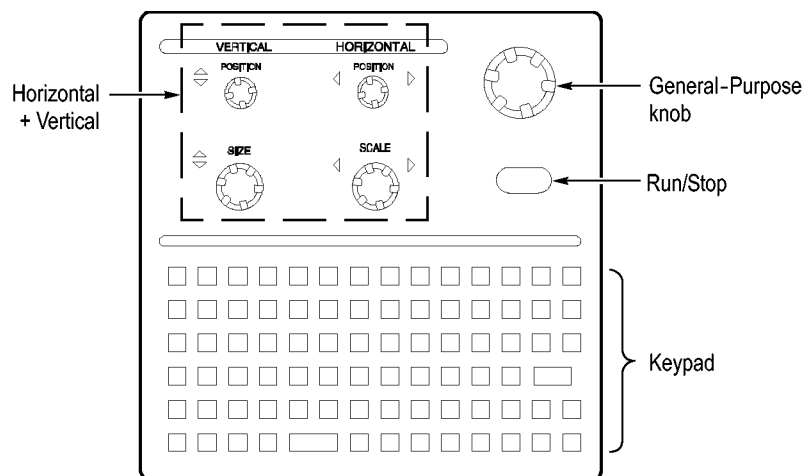

Figure 5: Logic analyzer front panel

External Connectors

Use the external connectors on the rear panel of the logic analyzer to connect external accessories. (See Figure 2 on page 4.)

Use the four front panel BNC connectors to send signals between the logic analyzer and other instruments. For example, use the iView cable to connect the logic analyzer to an oscilloscope.

Restoring and Installing Software

Most of the software comes factory-installed when you receive your logic analyzer. Refer to this section if you need to reinstall the operating system and the TLA application software. These instructions refer only to reinstalling the application software and operating system. This section also provides information on installing related logic analyzer software on a PC for remote operation or for offline applications.

NOTE. *If you install or reinstall software on a remote PC, make sure that the software version matches that of the main application on the logic analyzer.*

Restoring the Instrument Operating System

You can restore the instrument operating system from either a file on the instrument hard disk drive or from the set of instrument restore discs. (See page 8, *Creating Operating System Restore Discs.*) The preferred restore method is to use the hard disk restore file.



CAUTION. *Restoring the operating system reformats the hard disk drive. All saved data will be lost. If possible, save important files to external media before restoring the operating system.*

Restoring the Operating System from the Instrument Hard Disk

The instrument contains an operating system restore file on a separate partition of the hard drive.

1. Restart the instrument. During the startup process, you will see the following message at the top of the screen:

```
Starting Acronis Loader... press F5 for Acronis Startup  
Recovery Manager
```

2. Repeatedly press the F5 key until the Acronis True Image Tool opens. There is a short delay from the time the message appears until the instrument proceeds with the normal instrument startup. If the instrument does not open the Acronis application, power off the instrument, and then power on the instrument and try again.
3. Click Restore.
4. In the Confirmation dialog box, click Yes to restore the instrument operating system, or No to exit the restore process. The restore process takes approximately 30 minutes; the actual time depends on the instrument configuration.
5. When prompted, read and accept the end-user license agreement (EULA).
6. Click Next and then configure your regional settings, as needed.
7. Click Next.

The instrument will apply the settings and then restart.

8. After the instrument restarts, reinstall the TLA Application software. (See page 16, *Reinstalling the TLA Application Software*.)

Restoring the Operating System from the Restore Discs

You can only use the restore discs on the instrument that created them.

NOTE. *This procedure requires that the DVD drive is set as the first startup device (this is the default setting). If necessary, you can change the startup setting. (See page 16, Change the BIOS Settings.)*

1. Insert restore disc 1 into the instrument DVD drive.
2. Restart the instrument. The restore software opens automatically if the DVD drive is the first startup device. If the DVD drive is not the first startup device, you need to enable it as the first startup device before performing a restore from the restore discs.
3. Click Restore.
4. In the Confirmation dialog box, click Yes to restore the operating system and instrument application, or No to exit the restore process.
5. When the restore process is completed, remove the restore disc and restart the instrument.

NOTE. *Remove the restore disc before restarting the instrument. Otherwise the instrument will not start properly.*

6. When prompted, read and accept the end-user license agreement (EULA).
7. Click Next and then configure your regional settings, as needed.
8. Click Next.

The instrument will apply the settings and then restart.

9. After the instrument restarts, reinstall the TLA Application software. (See page 16, *Reinstalling the TLA Application Software.*)

Change the BIOS Settings

Before reinstalling the operating system, you may need to change the BIOS settings to enable starting the logic analyzer from the DVD drive.

1. For TLA5000B instruments (serial numbers below B050000), restart the instrument, press function key F2 repeatedly to enter the BIOS setup, and then go to the Boot menu.
2. For TLA5000B instruments (serial numbers above B050000), restart the instrument, press the Delete key repeatedly to enter the BIOS setup, and then go to Advanced BIOS Features.
3. Follow the on-screen instructions to change the settings so that the CD/DVD drive is before the hard disk drive in the boot order.
4. Save the settings by pressing function key F10 and confirm that you want to save the new settings.

Reinstalling the TLA Application Software

Complete the following steps to reinstall the latest version of the TLA application software. Use these steps as a first resort to recovering from application software problems. If you still experience problems you may have to restore the operating system. (See page 13, *Restoring the Instrument Operating System*.)

When using this procedure with the logic analyzer you will be asked to log on as Administrator. The logic analyzer is initially set up to automatically log on as Administrator (with no password) so you may not see the login prompt. If the network setups have been changed on your instrument, make sure that you log on as Administrator or as a user who has administrator privileges. Failure to do so can prevent the software upgrade from completing successfully.

1. Log on to the instrument as Administrator and quit any applications.
2. Insert TLA Application Software (CD 1 of 2) into the CD drive.
3. Browse to the TLA Application software folder on the CD and run the Setup.exe program.
4. Follow the on-screen instructions.

If you have an older version of the software on the hard disk, the installation program will detect it and ask if you want to remove it. Follow the on-screen instructions to remove the software, answering "Yes" to any prompts. Restart the instrument when prompted. Repeat Step 3 to reinstall the software.

Installing the TLA Application Software on a PC

You can install the TLA application software on a PC for the following purposes:

- Run the TLA application software in the Offline mode.
- Control a logic analyzer with the same TLA Application Software over a network.

Third-Party Software. To use all of the features of the TLA application software on your PC, you must install additional third-party software. The following third-party software is available on the TLA Application Software CD V5.0, or higher:

- The NI-GPIB-USB software allows you to use the iView software with your PC.
- The SnagIt software is useful for copying screen shots of logic analyzer data for use with other applications.

NOTE. *Several third-party software applications are included to use with your logic analyzer. These applications may include software license agreements. Be sure to abide by those license agreements.*

Install the NI-GPIB-Software. Complete the following steps to install the third-party software on your PC:

1. Install the first TLA Application Software CD in the CD drive.
2. Browse to the NI-GPIB-USB folder on the CD and run the Setup.exe program.
3. Follow the on-screen instructions and note the items below:
 - When prompted, select the **Typical** installation option.
 - When the Add GPIB wizard appears, select **GPIB-USB-B**.
 - After restarting the instrument, the NI-488.2 Getting Started wizard displays. This is not needed; select **Do not show at Windows startup**.
 - When you first connect the iView cable, the instrument will detect the new hardware. Select **Install the software automatically (Recommended)**.

Install the SnagIt Software. Complete the following steps to install the SnagIt software on your PC:

1. Browse to the SnagIt folder on the CD and run the Setup.exe program.
2. Follow the on-screen instructions.

Install the TLA Application Software. Browse to the TLA Application software folder on the CD and run the Setup.exe program. Follow the on-screen instructions to install the TLA application software.

If you have an older version of the software on the hard disk, the installation program will detect it and ask if you want to remove it. Follow the on-screen instructions to remove the software, answering "Yes" to any prompts. Restart the instrument when prompted and run the Setup.exe program again.

Start the TLA Application. If you have installed the TLA application software on a PC for remote operation, start the software by double-clicking on the TLA Application icon. The TLA Connection dialog box displays.

1. Select an instrument in the TLA Connection dialog box, and then click **Connect**. If your instrument is connected to a network, you can connect to any unused instrument on your local network.
2. Click **Offline** to start an offline version of the TLA application software. The TLA Offline software allows you to run the TLA application without connecting to an instrument. You can analyze previously acquired data from a logic analyzer, create or modify reference memories, or perform system tests without being connected to an instrument.

Upgrading or Restoring Firmware

You may have to upgrade the firmware on the logic analyzer if the firmware version is not compatible with the current TLA application software version. The most current firmware for the TLA application software resides in a file on the hard disk of the logic analyzer.

1. Exit the logic analyzer application.
2. Click Start > Programs > Tektronix Logic Analyzer > TLA Firmware Loader. If the TLA Connection dialog box displays, select an instrument, and click the **Connect** button.
3. Select the module from the Supported list box near the top of the window.
4. Select Load Firmware from the Execute menu.
5. Click the TLA520x.lod file.
6. Click OK. You will be prompted to confirm your action; click Yes.
7. Locate the big label on the back of the instrument.
8. Record the firmware version that is printed on the label. You will need this information to see that the firmware version matches the label.
9. Power on the instrument.
10. After the logic analyzer completes the power-on diagnostics, select System Properties from the System menu.
11. Click the LA1 tab.
12. Verify that the firmware version matches the version on the label that you recorded earlier.
13. If the firmware versions do not match, update the label on the back of the instrument.

Appendix A: User Service Procedures

This appendix describes high-level service information and procedures for the Tektronix logic analyzers. Additional troubleshooting procedures are located in the service manual.

General Care

Protect the instrument from adverse weather conditions. The instrument is not waterproof.

Do not store or leave the instrument where the LCD display will be exposed to direct sunlight for long periods of time.



CAUTION. To avoid damage to the instrument, do not expose it to sprays, liquids, or solvents.

Self Calibration

Use the Self Calibration property page to run self calibration procedures for the instrument. You will want to run these procedures after repair. At a minimum, run these procedures once a year.

Perform self-calibration after a 30 minute warm up.

Complete the following steps to run the self-calibration procedure:

1. From the System menu and select Calibration and Diagnostics.
2. Click the Self Calibration tab.
3. Select the instrument to calibrate.
4. Click the Run button.

Preventive Maintenance

Once a year the electrical performance should be checked and the instrument accuracy should be certified (calibrated). This service must be performed by a qualified service technician using the procedures outlined in the appropriate service manual for the Tektronix Logic Analyzer product.

Preventive maintenance mainly consists of periodic cleaning. Periodic cleaning reduces instrument breakdown and increases reliability. Clean the instrument as needed, based on the operating environment. Dirty conditions may require more frequent cleaning than computer room conditions.

Cleaning the Flat Panel Display

The LCD flat panel is a soft plastic display and must be treated with care during cleaning.



CAUTION. *Improper cleaning agents or methods can damage the flat panel display.*

Do not use abrasive cleaners or commercial glass cleaners to clean the display surface.

Do not spray liquids directly on the display surface.

Do not scrub the display with excessive force.

Avoid getting moisture inside the instrument while cleaning the display; use only enough solution to dampen the wipe.

Clean the flat panel display surface by gently rubbing the display with a cleanroom wipe (such as Wypall Medium Duty Wipes, #05701, available from Kimberly-Clark Corporation).

If the display is very dirty, moisten the wipe with distilled water or a 75% isopropyl alcohol solution and gently rub the display surface. Avoid using excess force or you may damage the plastic display surface.

Exterior Surfaces

Clean the exterior surfaces with a dry, lint-free cloth or a soft-bristle brush. If dirt remains, use a cloth or swab dampened with a 75% isopropyl alcohol solution. A swab is useful for cleaning in narrow spaces around the controls and connectors. Do not use abrasive compounds on any part of the instrument.



CAUTION. *To avoid damaging the instrument, follow these precautions:*

Avoid getting moisture inside the instrument during external cleaning and use only enough solution to dampen the cloth or swab.

Do not wash the front-panel On/Standby switch. Cover the switch while washing the instrument.

Use only deionized water when cleaning. Use a 75% isopropyl alcohol solution as a cleanser and rinse with deionized water.

Do not use chemical cleaning agents; they may damage the instrument. Avoid cleaning agents that contain benzene, toluene, xylene, acetone, or similar solvents.

In Case of Problems

This section provides information to help you address problems you may encounter while installing and using your logic analyzer.

Diagnostics The logic analyzer runs power-on diagnostics every time you power on the instrument. You can view the results of the diagnostics by selecting Calibration and Diagnostics from the System menu. You can run more detailed diagnostics by selecting Extended diagnostics. Here you can run all tests, loop on one or more tests, or loop on a test until a failure occurs.

The following diagnostic tools are available with your logic analyzer:

Power-On Diagnostics. Power-on diagnostics run when you turn on the logic analyzer, or when you start the TLA or the pattern generator application. If any diagnostic failures occur during turn on, the Calibration and Diagnostics property page appears.

Extended Diagnostics. Extended diagnostics test the logic analyzer more thoroughly than the power-on diagnostics. You can use the extended diagnostics to isolate problems to an individual module.

Before running the extended diagnostics, disconnect any attached probes.

TLA Mainframe Diagnostics. The TLA mainframe diagnostics program is a stand-alone application. These diagnostics check the operation of the mainframe beyond the basic PC circuitry. These diagnostics also check the front-panel knobs of the instrument.

Other Diagnostic Software. Other diagnostic software may be installed on your instrument and accessible from the Windows Start menu. This diagnostic software may vary depending on your instrument. Use the online help that comes with the diagnostic software or check with your local Tektronix representative for additional information on troubleshooting instrument problems.

Software Problems Your logic analyzer comes with most software installed. Before running any of the diagnostics, check the online release notes to verify that the logic analyzer software is compatible with the module firmware.

Many software problems can be due to corrupted or missing software files. In most cases the easiest way to solve software problems is to reinstall the software and follow the on-screen instructions. (See page 13, *Restoring and Installing Software*.)

If you suspect problems with the application software, contact your local Tektronix representative.

Hardware Problems If you are certain that you have installed the logic analyzer correctly, run the extended diagnostics (located under the System menu) to identify any problems. If your logic analyzer powers on so that you have access to the desktop, run any other diagnostic software on your instrument to identify possible problems.

Network Connection Problems

Version 5.0 or higher of the TLA application software allows you to connect your instrument to a network where you can control the instrument from a PC. Verify that the PC and the logic analyzer are connected to the network. The TLA application software must be installed on the PC and the logic analyzer. The TLA server must be running on the logic analyzer.

Complete the following steps to start the TLA server:

1. On the logic analyzer, click Start > Programs > Tektronix Logic Analyzer > TLA Server. An icon with a red circle appears in the toolbar.
2. Right-click the TLA Server icon and select **Start TLA Server**. The red circle disappears indicating the server is running.

Check with your system administrator to address other network problems.

Check for Common Problems

Use the following table to isolate problems. This list is not exhaustive, but it may help you eliminate problems that are easy to fix, such as an open fuse.

Table 4: Failure symptoms and possible causes

Symptom	Possible causes and recommended action
Instrument does not turn on.	Verify that the power cord is connected to the instrument and to the power source. Check that the instrument receives power when you press the On/Standby switch. Check that fans start and that front-panel indicators light. Check that power is available at the power source. Instrument failure: contact your local Tektronix service center.
External monitor does not turn on.	Check the monitor power cord connection. Check for failed fuse, if one exists. Check external display connection. Monitor failure: contact the vendor of your monitor for corrective action.
Monitor display is blank.	Check that the monitor is connected to the mainframe; replace the cable if necessary. If instrument display is blank, try connecting an external monitor; if both displays are blank, contact your local Tektronix service center. External monitor controls turned down; adjust monitor controls for brightness and contrast. Check the controller BIOS setups for the monitor. Faulty monitor: contact the vendor of your monitor for corrective action.

Table 4: Failure symptoms and possible causes (cont.)

Symptom	Possible causes and recommended action
Instrument turns on but does not complete the power-on sequence.	Make sure that the instrument boots from the hard disk drive. Remove any disks from the floppy disk drive. Possible software failure or corrupted hard disk drive; see <i>Software Problems</i> at the beginning of this chapter.
Power-on diagnostics fail.	Instrument failure: contact your local Tektronix service center.
Instrument does not recognize accessories such as monitor, printer, or keyboard.	Check that accessories are properly connected or installed. Try connecting other standard PC accessories or contact your local Tektronix service center.
Windows comes up but the TLA application does not.	Instrument not set up to start the TLA application at power-on. Start application from the desktop, by double-clicking the TLA icon located on your desktop. Faulty or corrupt software. Reinstall the application software.
Windows comes up in Safe mode.	Exit the Safe mode and restart the instrument. Incompatible hardware and hardware driver software. Either install hardware driver or remove the incompatible hardware.
Application starts but modules do not display in System window.	Firmware has not been updated. Instrument failure: contact your local Tektronix service center.

Repacking for Shipment

If a mainframe or module is to be shipped to a Tektronix service center for repair, attach a tag to the mainframe or module showing the owner's name and address, the serial number, and a description of the problem(s) encountered and/or service required. Always include the module and the probes so that the entire unit can be tested.

When packing an instrument for shipment, use the original packaging. If it is unavailable or not fit for use, contact your Tektronix representative to obtain new packaging.

Appendix B: Accessories and Options

Standard Accessories

Quantity	Accessory	Part number
1	TLA Family Application Software CD	—
1	Mouse, optical, wheeled, USB	119-7054-xx
1	Front-Panel Cover	200-4651-xx
1	Nero CD and license	—
1	Windows XP Professional Certificate of Authenticity	—
1	CheckIt Utilities Sticker	—
1	TLA Mouse Pad	016-1524-xx
1	Certificate of Traceable Calibration	—
2	Probe retainer brackets with fasteners (TLA5201B)	407-4435-xx
4	Probe retainer brackets with fasteners (TLA5202B)	407-4435-xx
6	Probe retainer brackets with fasteners (TLA5203B)	407-4435-xx
8	Probe retainer brackets with fasteners (TLA5204B)	407-4435-xx
1	Literature Package	001-1366-xx

Optional Accessories

Accessory	Part number
17-channel general purpose probe	P6410
17-channel high-density compression probe	P6419
34-channel high density mictor probe	P6434
Single-ended high-density logic analyzer probe with D-Max™ Probing Technology	P6450

Options

Option	Description	Part number
1C	Add iView External Oscilloscope Cable Kit	012-1614-xx
8S	Increase acquisition record length to 8 M @ 235 MHz	—
9S	Increase acquisition record length to 32 M @ 235 MHz	—
A0	North America Power Cord	161-0104-00
A1	Universal Euro Power Cord	161-0104-06
A2	United Kingdom Power Cord	161-0104-07
A3	Australia Power Cord	161-0104-14

Option	Description	Part number
A4	240 V North America Power Cord	161-0104-08
A5	Switzerland Power Cord	161-0167-00
A6	Japan Power Cord	161-0322-00
A10	China Power Cord	161-0306-00
A11	India/South Africa Power Cord	161-0324-00
A99	No power cord or AC adapter (Option A99)	—

Index

ENGLISH TERMS

- Accessories, 27
 - connecting, 4
 - optional accessories, 27
 - standard accessories, 27
- Chassis ground location, 3
- Checking the shipping list, 1
- Cleaning, 22
 - LCD display, 22
- Connecting
 - accessories, 4
 - probes, 5
- Customer registration card, 1
- Diagnostics, 23
 - extended, 23
 - instrument, 23
 - power on, 23
 - TLA Mainframe, 23
- Documentation, v
- Extended diagnostics, 23
- Firmware
 - upgrading, 19
- Front panel controls, 11
- General maintenance, 21
- Incoming inspection
 - checking probes, 9
 - performing, 9
- Installing
 - software, 16
 - software on a PC, 17
- Keypad, 11
- Logic analyzer
 - chassis ground connections, 3
 - connecting probes, 5
 - incoming inspection, 9
 - installing software, 13
 - reinstalling software, 13
 - self calibration, 21
 - shipping list, 1
 - site considerations, 1
- Logic analyzer description, iv
- Maintenance
 - common problem
 - checklist, 24
 - installing software, 13
- Network connection problems, 24
- Operating system
 - restoring, 13
- Operating system restore discs, 8
- Optional accessories, 27
- Options, 27
- OS restore discs, 8
- Power requirements, 2
- Power-on diagnostics, 23
- Preventive maintenance, 21
 - cleaning, 22
 - LCD display, 22
- Probes
 - connecting, 5
- Problems
 - checklist, 24
 - software, 23
- Registration card, 1
- Reinstalling software
 - TLA application software, 16
- Related documentation, v
- Release notes, 9
- Remote operation, 18
- Repacking for shipment, 25
- Requirements
 - site consideration, 1
- Restoring the operating system, 13
- Self calibration, 21
- Service
 - common problem
 - checklist, 24
 - instrument diagnostics, 23
- Service, user
 - preventive maintenance, 21
- Shipping, 25
- Shipping list, 1
- Site considerations
 - altitude, 1
 - clearance, 2
 - environmental, 1
 - humidity, 1
 - power requirements, 2
 - temperature, 1
- Software
 - extended diagnostics, 23
 - installing, 13, 16
 - installing on a PC, 17
 - other diagnostics, 23
 - power on diagnostics, 23
 - problems, 23
 - third-party, 17
 - TLA Mainframe
 - diagnostics, 23
- Standard accessories, 27
- Third-party software, 17
- TLA Offline, 18
- TLA Server, 24
- Troubleshooting, 23
 - common problem
 - checklist, 24
 - network problems, 24
- Upgrading firmware, 19
- User service
 - general maintenance, 21
 - preventive maintenance, 21