

GSM SERIES LINEAR ACTUATOR INSTALLATION AND SERVICE MANUAL



Information furnished by EXLAR Corporation is believed to be accurate and reliable. However, no responsibility is assumed by EXLAR Corporation for its use. EXLAR reserves the right to change the design and operation of the equipment described herein and any associated motion products that may appear in this document. Information in this document pertaining to equipment not furnished by EXLAR should be confirmed by that equipment manufacturer. EXLAR assumes no responsibility for changes to information by other manufacturers or errors in that information or the description of that information. Information in this document is subject to change without notice.

TABLE OF CONTENTS

1.0 Introduction	3
1.1 Warranty and Limitations of Liability	3
1.2 Safety Considerations	4
2.0 System Configuration	4
2.1 Typical System Configuration	4
2.2 Typical System Wiring	5
2.3 Feedback Information	5
2.4 Cable Routing	6
2.5 Anti-Rotation Option	7
2.6 External Limit Switch Option	8
2.7 Rear Brake Option	9
2.8 Ingress Protection	10
3.0 Installation and Operation	11
3.1 Lubrication Requirements	11
3.2 Mounting Configurations	11
3.3 Mounting Considerations	11
3.4 General Operation	12
3.5 Manual Drive Operating Instructions	13
4.0 Maintenance Procedures	14
4.1 Disassembly	14
4.2 Lubrication Maintenance	15
4.3 Reassembly	15
4.4 Seal Maintenance	16
5.0 Class I Division 2 Option	18
5.1 Terminal Box Wiring Diagram	18
5.2 Class I Div 2 Terminal Box Terminations	19
5.3 Terminal Box Dimensions	20
6.0 Troubleshooting Procedures	21
6.1 Returning a Product for Repair	22
7.0 Certifications	23

Refer to www.exlar.com for connector and wiring information.

1.0 INTRODUCTION

1.1 Warranty and Limitation of Liability

Products are warranted for two years from date of manufacture as determined by the serial number on the product label. Labels are generated and applied to the product at the time of shipment. The first and second digits are the year and the third and fourth digits represent the manufacturing week. Product repairs are warranted for 90 days from the date of the repair. The date of repair is recorded within Exlar Corporation's database tracked by individual product serial number.

Exlar warrants its product(s) to the original purchaser and in the case of original equipment manufacturers, to their original customer to be free from defects in material and workmanship and to be made only in accordance with Exlar's standard published catalog specifications for the product(s) as published at the time of purchase. Warranty or performance to any other specifications is not covered by this warranty unless otherwise agreed to in writing by Exlar and documented as part of any and all contracts, including but not limited to purchase orders, sales orders, order confirmations, purchase contracts and purchase agreements. In no event shall Exlar be liable or have any responsibility under such warranty if the product(s) has been improperly stored, installed, used or maintained, or if Buyer has permitted any unauthorized modifications, adjustments and/or repairs to such product(s). Seller's obligation hereunder is limited solely to repairing or replacing (at its opinion), at the factory any product(s), or parts thereof, which prove to Seller's satisfaction to be defective as a result of defective materials, or workmanship and within the period of time, in accordance with the Seller's stated product warranty (see Terms and Conditions above), provided, however, that written notice of claimed defects shall have been given to Exlar within thirty (30) days from the date of any such defect is first discovered. The product(s) claimed to be defective must be returned to Exlar, transportation prepaid by Buyer, with written specification of the claimed defect. Evidence acceptable to Exlar must be furnished that the claimed defects were not caused by misuse, abuse, or neglect by anyone other than Exlar.

Components such as seals, wipers, bearings, brakes, bushings, gears, splines, and roller screw parts are considered wear parts and must be inspected and serviced on a regular basis. Any damage caused by failure to properly lubricate Exlar products and/or to replace wear parts at appropriate times, is not covered by this warranty. Any damage due to excessive loading is not covered by this warranty.

The use of products or components under load such that they reach the end of their expected life is a normal characteristic of the application of mechanical products. Reaching the end of a product's expected life does not indicate any defect in material or workmanship and is not covered by this warranty.

Costs for shipment of units returned to the factory for warranty repairs are the responsibility of the owner of the product. Exlar will return ship all warranty repairs or replacements via UPS Ground at no cost to the customer.

For international customers, Exlar will return ship warranty repairs or replacements via UPS Expedited Service and cover the associated shipping costs. Any VAT or local country taxes are the responsibility of the owner of the product.

The foregoing warranty is in lieu of all other warranties (except as Title), whether expressed or implied, including without limitation, any warranty of merchantability, or of fitness for any particular purpose, other than as expressly set forth and to the extent specified herein, and is in lieu of all other obligations or liabilities on the part of Exlar.

Seller's maximum liability with respect to these terms and conditions and any resulting sale, arising from any cause whatsoever, including without limitation, breach of contract or negligence, shall not exceed the price specified herein of the product(s) giving rise to the claim, and in no event shall Exlar be liable under this warranty otherwise for special, incidental or consequential damages, whether similar or dissimilar, of any nature arising or resulting from the purchase, installation, removal, repair, operation, use or breakdown of the product(s) or any other cause whatsoever, including negligence.

The foregoing warranty shall also apply to products or parts which have been repaired or replaced pursuant to such warranty, and within the period of time, in accordance with Seller's stated warranty.

NO PERSON INCLUDING ANY AGENT OR REPRESENTATIVE OF EXLAR, IS AUTHORIZED TO MAKE ANY REPRESENTATION OR WARRANTY ON BEHALF OF EXLAR CONCERNING ANY PRODUCTS MANUFACTURED BY EXLAR, EXCEPT TO REFER PURCHASERS TO THIS WARRANTY.

1.2 Safety Considerations

As with any electro-mechanical device, safety should be considered during the installation and operation of your GSM Series actuator. Throughout this manual you will see paragraphs marked with CAUTION and WARNING signs as shown below.

CAUTION



WARNING



Pay particular attention to these paragraphs. They are intended to provide you with helpful information to ensure safe and trouble-free installation.

2.0 SYSTEM CONFIGURATION

2.1 GSM Series Actuator System Configuration

GSM Series actuators incorporate an integral brushless servo motor. The design of this motor and selection of the proper feedback configuration allows GSM Series actuators to be powered by nearly every brand of brushless motor amplifier on the market.

This flexibility allows GSM Series actuators to be incorporated into the highest performance single and multi-axis motion control systems in use today. In applications varying from food and beverage packaging to multi-axis turning centers to aircraft assembly, the GSM Series of actuators show incredible performance and durability.

The high torque to volume ratio available from a brushless motor, combined with the robust, high speed and high load capability of the planetary roller screw, make the Exlar line of linear actuators a true, all electric replacement for cumbersome high maintenance hydraulics. The use of electronic servo control provides simpler set up and more precise control than hydraulic systems as well.

The schematic, next page, shows the typical connections for a single axis system incorporating an Exlar GSM Series actuator and servo amplifier. Each brand of brushless motor amplifiers may have unique wiring requirements, parameter settings and operational principals that affect how the actuator operates. The drawing on the following page shows general connection principals for typical resolver and encoder feedback amplifiers. Details on connections to specific brands of amplifiers can be obtained from www.exlar.com.



WARNING: Attempting to connect the power cable to the motor feedback connector may cause damage to the connector. Verify that pin patterns match before attempting to connect cables to actuator.

Never attempt to connect or disconnect the actuator with power applied. Dangerous voltages are present. Damage to equipment and injury to personnel can result. Many amplifiers have voltage present for a considerable time period after incoming power is removed. Take care to insure that the amplifier has discharged all power.

Typical System Connections

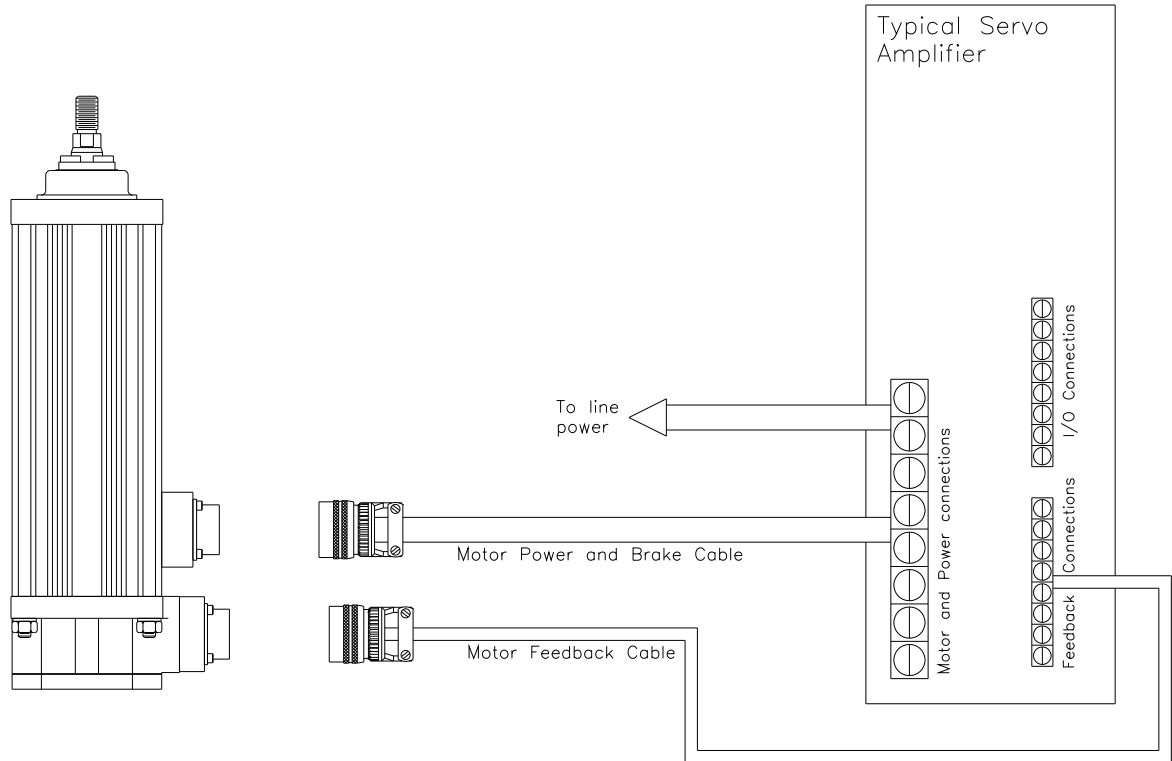

2.2 Typical System Wiring

Please refer to www.exlar.com for information on connectors and wiring.

2.3 Feedback Information

GSM Series actuators incorporate a quadrature incremental encoder with commutation signals as the primary rotary feedback device. The alignment of this feedback device is dictated by the amplifier that the end user chooses for operating the actuator. This amplifier is indicated in the model number of the GSM Series actuator as a 3 digit code consisting of 2 letters and 1 number.

Each amplifier has specific requirements for the feedback on the motor. Not all encoder-based amplifiers can use the same encoder, encoder alignment or relative direction of encoder rotation.

Many amplifiers offer software that allows the entering of parameters or the downloading of motor data files that dictate how the feedback must be set up on the motor. Exlar can provide many of these data files or the proper parameters to enter. Entering motor parameter data to some amplifiers may require assistance from the amplifier manufacturer.

Feedback Alignment

When Exlar manufactures a GSM Series actuator, the proper feedback is selected, mounted, aligned and test run on the amplifier that the customer plans to use, or one that is known to be equivalent for confirming proper feedback alignment and operation. In any case where it is determined that the feedback has become misaligned, or an amplifier change is made requiring the feedback to be aligned differently, it is recommended that Exlar be contacted and arrangements made to have that procedure performed.

Feedback Wiring

The wiring of the feedback device is critical to the operation of the actuator with the selected amplifier. Wiring the feedback cable improperly can cause unstable operation, incorrect operation or no operation at all. In some cases, if the proper current limits are not set in the amplifier, improper wiring of the feedback cable can lead to damage of the motor.

Encoders

An incremental encoder is an electronic rotary device that transmits a string of electrical pulses when rotated. Most brushless motors or servo systems that use incremental encoders use what is called a quadrature encoder. Typical brushless motor encoders use two data channels, labeled A&B, to provide direction, velocity and position information. The Channel labeled I or Z has one pulse per revolution and is called the index. The channels labeled as hall signals, or commutation signals, are typically labeled S1, S2 & S3; Hall 1, 2 & 3, or Hall A, B & C, depending on the manufacturer's conventions. These signals give the amplifier the commutation information that it needs to properly rotate the motor.

GSM Series Feedback Devices

Standard GSM Series actuators use encoders as their primary feedback device. Depending on the amplifier that will be used to operate the actuator, the hookup of the actuator can vary. Always consult Exlar for the correct wiring details or visit www.exlar.com.

2.4 Cable Routing

Over time, liquid contaminants such as oil and cleaning solutions will run down the cables and into any exposed connectors. To minimize the introduction of contaminants to the connector, route the cables so that there is a loop in the cable just prior to its attachment to the connector.

Two examples are shown below, depending on the orientation of the connectors. Units mounted in such a way that the connectors are on the bottom surface of the actuator require no looping.

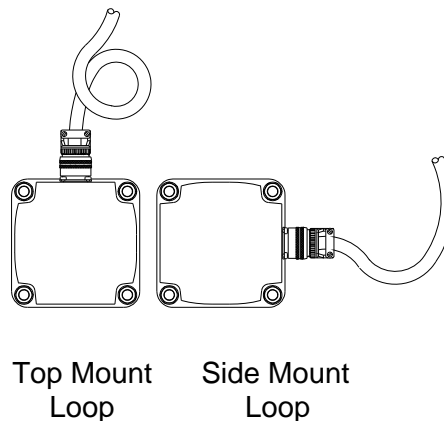

2.5 GSM Series Linear Actuator Anti-rotation Option

The unique design of the GSM Series linear actuators allows the extending rod to rotate. This simplifies the setup of the actuator by allowing the user to rotate the rod and thread it in and out of the actuator for mechanical attachment or system testing.

This feature also requires that the rod be kept from rotating when used in its dedicated application to insure proper linear motion. In most applications, such as those where the load is coupled to linear bearings or some other support device, the load cannot rotate, providing anti-rotation for the extending rod of the actuator.

For applications in which the load is free to rotate, Exlar offers the anti-rotation systems shown below. The drawings below show the rod and bushing on only one side of the actuator. For long stroke actuators, the rod and bushing are required on both sides of the actuator.

Anti-Rotate Option Dimensions

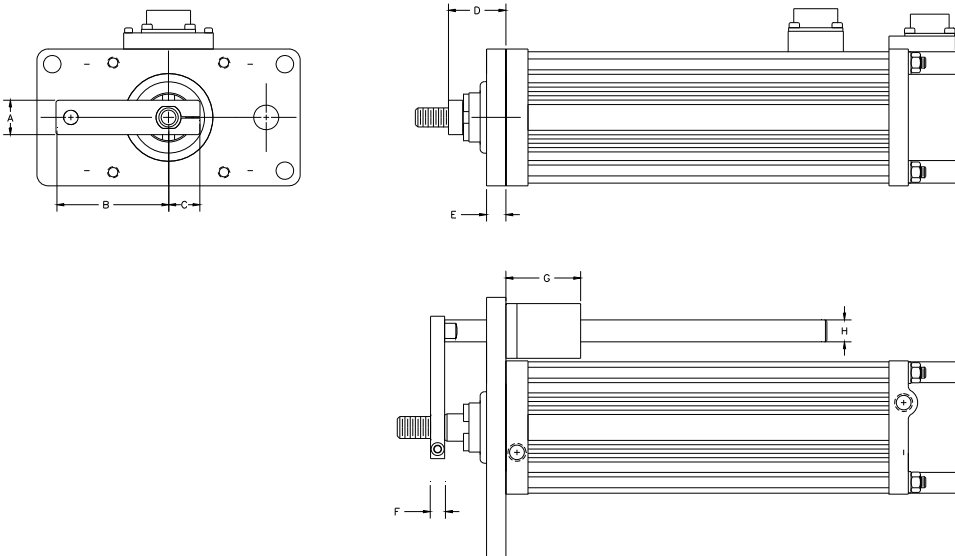

Dimensions in inches	GSM20	GSM30	GSM40
A	0.60	0.79	1.25
B	1.81	2.54	3.78
C	0.54	0.71	0.98
D	1.00	1.29	1.65
E	0.44	0.44	0.63
F	0.28	0.32	0.38
G	0.31	1.69	1.69
H	0.37	0.50	0.50

2.6 GSM Linear Actuator External Limit Switch

With the anti-rotate option (Section 2.6) the GSM actuator can accommodate 1, 2 or 3 external limit switches for use as end of travel limit switches or home position sensors in a low profile extruded channel housing. A bracket with inductive proximity switches mounts to the tie rods and senses a traveling magnet inside the extrusion.

External Limit Switch Dimensions

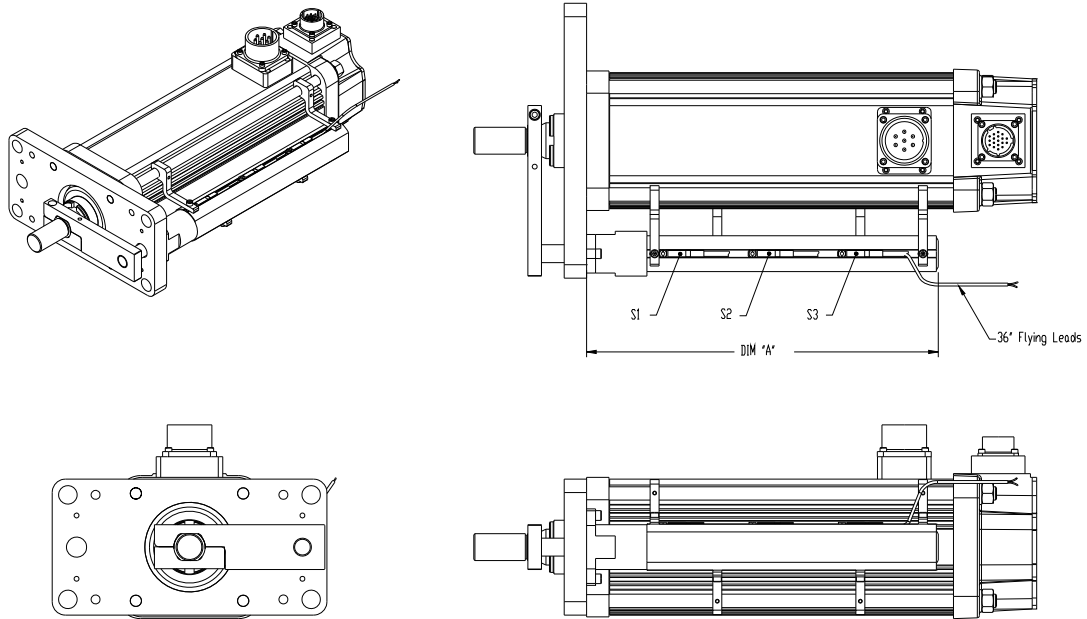

DIM "A"	3" Stroke	6" Stroke	10" Stroke	12" Stroke	18" Stroke
GSM20	5.515	8.515	<i>n/a</i>	14.515	<i>n/a</i>
GSM30	6.932	9.832	13.832	15.832	21.832
GSM40	<i>n/a</i>	9.832	13.832	15.832	21.832

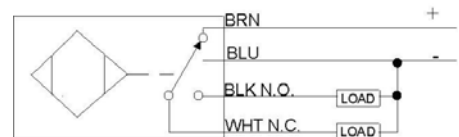

The number of switches desired is selected by ordering the L1, L2 or L3 option, in which 1, 2, or 3 switches will be provided, respectively.

The switches are 9-30 VDC powered, PNP output, with either normally open or normally closed logic operation depending on the switch configuration ordered. Below is a diagram indicating which logic operation will be provided for each switch, based on the option ordered.

CONFIGURATION OF LOGIC OF STANDARD SWITCH OPTION SELECTIONS			
Option	SW1	SW2	SW3
L1	Not Supplied	Normally Open	Not Supplied
L2	Normally Closed	Not Supplied	Normally Closed
L3	Normally Closed	Normally Open	Normally Closed

Switch Type	Exlar Part Number	Turck Part Number
Normally Closed Switch	43404	BIM-UNT-RP6X
Normally Open Switch	43403	BIM-UNT-AP6X

2.7 Internal Holding Brake

Many applications require the addition of the rear internal holding brake. The brake is held open by the supply of power to a magnetic/mechanical clutch. Whenever there is not power to the brake, the armature is held in place to prevent the inverted roller screw from turning and prevent the output rod from back driving, which therefore prevents the output rod from moving.

The holding brake is permanent magnet engaged and electrically released. The mechanical advantage of the roller screw allows the holding brake to prevent back driving of the load. The holding capacity of the brake is sufficient to hold the rated force of the actuator when used in grease lubricated units.

Historically, Exlar actuators and motors with holding brakes provided a transient suppression diode wired internally to the actuator or motor. With the changes in servo amplifier and control technology, there are now instances where the diode is not required to be within the motor. An example of this is a control system using a dedicated brake control relay containing transient suppression components.

Because of this change in technology, Exlar now provides the transient suppression diode separately from the actuator, for inclusion in the brake control circuitry as needed by the end user. A schematic is provided below showing the typical use of the transient suppression diode.

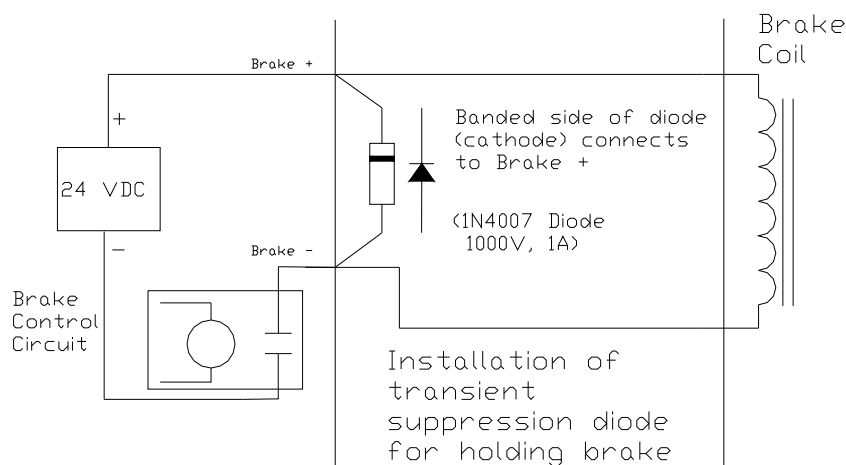

If the user is uncertain about the requirements for transient suppression, they should refer to their servo amplifier or controller technical documentation, or contact their servo amplifier or controller manufacturer for technical support.

For connection of your amplifier and actuator (including rear brake leads), refer to the wiring information at www.exlar.com/TI_install_scheme.html.

The rear brake option adds length to the dimensions of the GSM actuators as follows: (See drawings in Section 5.2.)

GSM20: Add 1.784 inches (45.3 mm) if ordering brake

GSM30: Add 1.6 inches (40.6mm) if ordering brake

GSM40: Add 2.33 inches (59.2 mm) if ordering brake

BRAKE SPECIFICATIONS	GSM20	GSM30	GSM40
Holding torque	19 lb-in	70 lb-in	97 lb-in
Voltage	24 VDC	24 VDC	24 VDC
Current required	0.75 Amps	0.75 Amps	0.88 Amps
Coil resistance (polarity sensitive)	70.6 Ohms	48 Ohms	36 Ohms



DO NOT attempt to operate the actuator with the brake applied. Allowing the actuator to operate with the brake applied may cause serious damage to the actuator and/or the brake. Do not use the brake to support heavy loads while an operator is under the load. Provide another means to lock the load in position. The brake is a spring applied friction mechanism and does not provide a positive lock.

2.8 Ingress Protection Rating

The standard IP rating for GSM Series actuators is IP54S with an option for IP65S. Ingress protection is divided into two categories; solids and liquids. For example, in IP65 the three digits following “IP” represent different forms of environmental influence:

- The first digit represents protection against ingress of solid objects.
- The second digit represents protection against ingress of liquids.
- The suffix digit represents conditions of motion during the operation.

Digit 1 - Ingress of Solid Objects

The IP rating system provides for 6 levels of protection against solids.

1	Protected against solid objects over 50mm e.g. hands, large tools.
2	Protected against solid objects over 12.5mm e.g. hands, large tools.
3	Protected against solid objects over 2.5mm e.g. wire, small tools.
4	Protected against solid objects over 1.0mm e.g. wires.
5	Limited protection against dust ingress. (no harmful deposit)
6	Totally protected against dust ingress.

Digit 2 - Ingress of Liquids

The IP rating system provides for 9 levels of protection against liquids.

1	Protected against vertically falling drops of water or condensation.
2	Protected against falling drops of water, if the case is disposed up to 15 degrees from vertical.
3	Protected against sprays of water from any direction, even if the case is disposed up to 60 degrees from vertical.
4	Protected against splash water from any direction.
5	Protected against low pressure water jets from any direction. Limited ingress permitted.
6	Protected against high pressure water jets from any direction. Limited ingress permitted.
7	Protected against short periods of immersion in water of 1m or less for 30 minutes or less.
8	Protected against long durations of immersion in water.
9	High-pressure, high-temperature wash-down applications.

Suffix

S	Device standing still during operation
M	Device moving during operation

3.0 INSTALLATION AND OPERATION

3.1 Lubrication Requirements

The GSM Series actuator is shipped from the factory fully greased and ready for installation. Exlar recommends using Mobilith SHC 220, a high performance, extreme-pressure grease. The unique physical properties of the synthetic base oil provides outstanding protection against wear, rust, corrosion and high or low-temperature degradation. Mobilith SHC allows for very low starting and running torque values. Its operating range is -40 degrees C to 177 degrees C (-40 degrees F to 350 degrees F).

3.2 Mounting Configurations

The standard configurations available are Rear Clevis, Front Flange, Extended Tie Rods, Side Trunnions and side tapped mounting holes. General drawings are shown in the product section guide.

3.3 Mounting Considerations

Every effort should be made to minimize misalignment. Any misalignment will decrease the life of the components within the actuator and also may create problems within the application associated with misalignment.



Excessive side load on the output rod of the actuator will dramatically reduce the life of the actuator and should be avoided completely. Side load can be caused from misalignment or loading that is not inline with the actuator output rod.

3.4 General Operation

The GSM Series linear actuators function in the same manner as a brushless servomotor. The servo amplifier is used to rotate the motor at controlled speed and torque, and for controlled numbers of revolutions and move times. This rotary motion is translated into linear motion by the internal planetary roller screw mechanism of the GSM Series linear actuator.

The relationships between the rotary motion of the motor and the linear motion of the actuator corresponds to the following relationships:

Linear Distance Traveled (in) = (Motor Revolutions)*(Roller Screw Lead)

Linear Speed (in/sec) = ((Motor RPM) / 60)*(Roller Screw Lead)

Linear Force (lbf) = ((Motor Torque (in-lbf))*(2 π)*(efficiency)) / (Roller Screw Lead (in))

All of the above relationships require proper anti-rotation of the GSM Series actuator rod. For more information on sizing and selection of GSM Series actuators and servo amplifiers, consult the sizing and selection section of the Exlar catalog.



Motor RMS current must be maintained at a level below the continuous current rating of the GSM Series actuator or damage to the motor stator will result.

The peak current setting must be maintained at a level below the peak current rating of the GSM Series actuator or damage to the stator will result.



Care should be taken not to exceed the physical travel limits of GSM Series Actuators. Doing so will cause the actuator to end-crash internally. End crashes can physically damage the roller screw and the internal components of the actuator. Care should be taken to avoid high speed impact with objects of high rigidity that immediately stop the travel of the actuator with no deceleration or energy absorption. An example would be a high speed impact of two solid steel parts. The resulting impact will create a very short effective deceleration time. Kinetic energy contained in the rotating inertia of the actuator and motor can possibly generate extremely high impact forces that exceed the mechanical capacities of the actuator and cause physical damage to the actuator. For applications requiring this type of impact, contact Exlar application engineering to insure that the actuator is properly sized or provisions made to absorb the induced energy.

3.5 Manual Drive Operating Instructions



Important: If manually driving through a brake or high force is necessary, please consult Exlar engineering. If a power tool is used to operate the manual drive the speed should be limited to 600 RPM. An impact driver should never be used to operate the manual drive. Extreme caution should be taken when approaching end of stroke of the actuator or system.

- 1) Press down on the hex until you feel you have bottomed out the manual drive. Constant downward force is required to maintain engagement during operation.
- 2) Give the hex a slight turn while observing if you are moving the rod or not. It is possible that during engagement the gear teeth have not completely engaged; this will prevent the gears from meshing. If the rod is not moving continue to press down while turning the manual drive slowly until it pushes farther down. When this happens you have proper gear engagement.
- 3) After gear engagement is achieved, the manual drive can be operated. The maximum torque input for the manual drive should not exceed the values shown in Table 1.
- 4) When the manual drive movement is completed, cease the downward force and the manual drive will disengage.

Table 1. Maximum operating conditions

Model	Maximum Torque in-lbs / (Nm)
GSM 20	10 / (1.1)
GSM 30	30 / (3.4)
GSM 40	40 / (4.5)

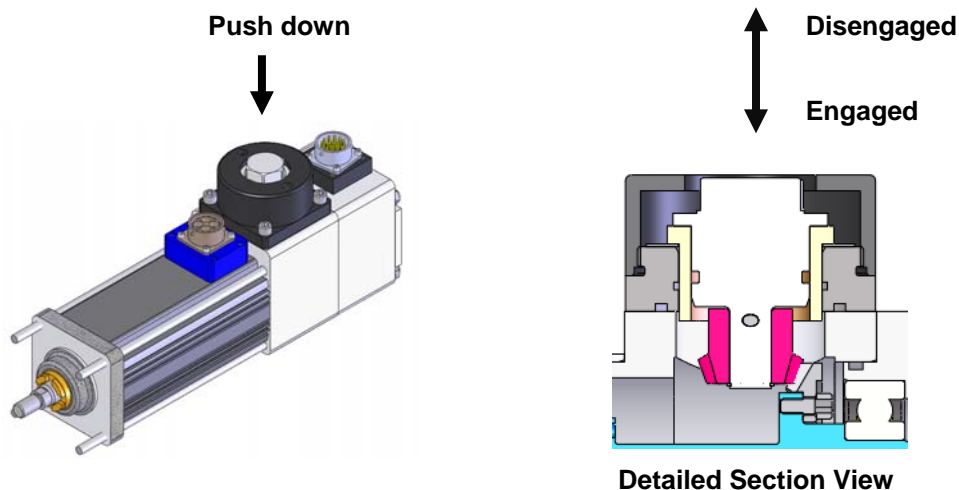

4.0 MAINTENANCE PROCEDURES

4.1 Disassembly



If your actuator has a preloaded roller screw, do not remove it from the cylinder. Preloaded screws require special tooling and procedures for proper disassembly and reassembly. Contact Exlar Corporation to arrange for maintenance of a preloaded screw actuator.

Refer to the exploded view on the following page.

1. Remove the actuator assembly from the machine by disconnecting the cables, main rod coupling and actuator mounting bolts or fasteners.
2. If your unit does not have an external anti rotate assembly, skip this step. Loosen the two machine screws that clamp the anti-rotate cross member to the actuator output rod. Slide the anti-rotate mechanism forward and off the actuator.
3. Remove the rear tie rod nuts from the back of the actuator.



The end cap houses the feedback device. Alignment of this feedback device to the phases of the motor is critical to the operation of the system. Extreme care should be taken when removing the tie rod nuts or tie rods so as not to twist or pull on the end cap of the actuator. Some feedback devices are sensitive to movement of their mounting surface once installed and can be damaged if care is not taken.

4. If your actuator does not have a front flange, skip this step. Slide the front flange forward and off the actuator. The tie rods will remain attached to the front flange.



If your actuator has a preloaded roller screw, do not remove it from the cylinder. Preloaded screws require special tooling and procedures for proper disassembly and reassembly. Contact Exlar Corporation to arrange for maintenance of a preloaded screw actuator.

5. When the face plate is removed, the thrust bearing and the open end of the roller screw internally threaded cylinder (ITC) are visible. The roller screw can be removed by turning it counter clockwise and threading it out of the cylinder. It may be necessary to keep the roller screw cylinder from turning to remove the screw.

4.2 Lubrication Maintenance

Grease lubricated units will require periodic inspection and renewal of the bearing and roller screw grease. The table below shows the recommended grease renewal period.

RMS Rotational speed(RPM)	Recommended Grease Renewal Period hours)		
	CASE TEMP 65°C (149°F)	CASE TEMP 80°C (176°F)	CASE TEMP 95°C (203°F)
250	10,000	5,000	2,500
500	8,500	4,250	2,125
1000	6,000	3,000	1,500
1500+	3,500	1,750	875

Grease Renewal

The bearings located in the front of the actuator, the roller screw cylinder, and the roller screw assembly are the components that require grease. They require a coating of grease. They do not need to be packed with grease. Excess grease requires more torque from the motor when returned to operation, and does not improve the lubrication of the unit.

- 1.) Use a brush to work approximately 0.5 in³ of grease for every 3 inches of stroke length into the roller screw cylinder. Be sure to cover all of the threaded areas of the cylinder.
- 2.) Use a brush to work grease in to the roller screw assembly. Be sure to cover all the threaded surfaces of the screw assembly. This can be accomplished by applying grease to a few places on the roller screw assembly and rotating the components repeatedly in both directions to work the grease into the assembly.
- 3.) Force grease into the front of the thrust bearing assembly. Make a concerted effort to insure that the grease is well worked in. Grease must reach the bearing just behind the bearing that is visible as well. Use the following amounts of grease for each size roller screw and bearing:
GSM20: 0.5 in³
GSM30: 0.75 in³
GSM40: 1.00 in³

4.3 Reassembly

1.) Rethread the roller screw into the internally threaded cylinder (ITC). It is a multiple start screw, and this is not always easy. **DO NOT FORCE THE ROLLER SCREW INTO THE CYLINDER.** It is best to have the actuator vertical with the open end of the roller screw cylinder facing up. Position the roller screw above the cylinder so that it is aligned axially with the ITC. Slowly turn the roller screw 1/4 to 1/2 a turn counterclockwise with it in contact with the ITC. This will help to align the threads on the roller screw with the threads in the ITC. Rotate the roller screw clockwise and it should begin to thread into the cylinder. If it does not turn freely, remove it and begin again. When threading the screw into the cylinder, it will roll freely into the actuator. When it reaches the portion of the cylinder that contains the motor magnets, the roller screw will be more difficult to turn because of the magnetic field of the magnets. **THIS IS NORMAL.** Continue to thread the roller screw into the cylinder. When it reaches the bottom, it will become difficult to turn and the motor and bearings will begin to rotate with it. The roller screw is now fully inserted into the cylinder.

- 2.) Place a small amount of seal lubricant on the inside surface of the seal/bushing assembly.

3.) Carefully slide the face plate and bushing/seal assembly over the actuator rod end, while guiding the tie rods through the holes in the rear end cap of the actuator. The seal is a tight fit on the rod end. Take care not to damage the seal on the threads of the extending rod. Standard GSM Series rods have a chamfer to provide a lead in for replacement of the seal and bushing. Be sure that the faceplate seats completely and squarely on the front of the actuator. The inner surface of the faceplate provides the pre-loading for the bearings, and it is important that it is properly seated.

Units With a Front Flange

Replace the faceplate as described above. Remount front flange by sliding tie rods through the holes in the faceplate and through the holes in the rear end cap. Pilot the flange on the pilot diameter located on the front of the faceplate.

4.) Replace the rear tie rod washers and nuts and tighten to the proper torque. Tighten the nuts simultaneously by partially tightening each in an opposing corner pattern until each is torqued to the rated value shown below.

GSM20: 20 lbf-in (1.7 lbf-ft, 2.26 N-m)

GSM30: 90 lbf-in (7.5 lbf-ft, 10.16 N-m)

GSM40: 240 lbf-in (20 lbf-ft, 27.12 N-m)

5.) If your actuator has an external anti-rotate mechanism, slide the rod or rods of the anti-rotate mechanism through the front flange and into the guide bushing or bushings mounted to the rear of the flange. Position the extending rod so that the wrench flats are parallel to the long side of the flange. Slide the cross member assembly of the anti-rotate mechanism over the end of the rod and onto the wrench flats. Tighten the two screws that clamp the assembly to the actuator rod.

4.4 Seal Maintenance

If you have chosen the IP65 sealing option (-P5) on your GSM actuator, it is recommended that the main rod seal and bushing assembly be replaced at the suggested time of lubrication. The main rod seal can be removed by threading it out of the face plate using a standard rod seal gland wrench or spanner wrench. A new main rod seal can be slid over the main rod, taking care not to touch the seal material to the threaded rod end. To have this service performed for you, contact Exlar Engineering or arrange with Exlar Returns Department to send your unit in for service.

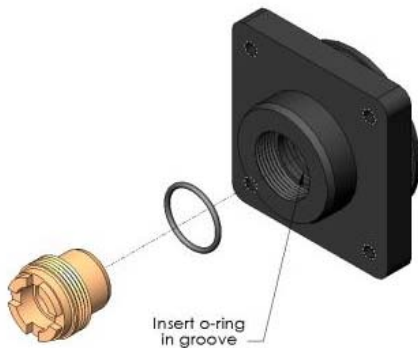

Main Rod Seal Gland and Bushing

	Standard Main Rod Seal Gland Part Numbers	Install Torque
GSM20	18929	100 lb-in (11.29 N-m)
GSM30	19020	200 lb-in (22.58 N-m)
GSM40	19021	360 lb-in (40.67 N-m)

Note: Some actuators are provided with special seals due to chemical exposure or other special requirements. Contact Exlar if there is a question about your particular actuator having a standard material main rod seal gland.

Main Rod Seal Gland Installation/Replacement:

1. Using proper sized gland or spanner wrench, remove existing seal from actuator face plate, and slide off the actuator rod. This will require the removal of any rod attachments. One source for gland wrenches is Martin Fluid Power, http://www.mfpseals.com/seal_repair_kits/parker-2.shtml.

Exlar Actuator Model	Martin Fluid Power Part No.	Size (in)	Description
GSM20-30	PH-0695900000	1/2, 5/8	Rod Gland Wrench
GSM40	PH-0695910000	1	Rod Gland Wrench

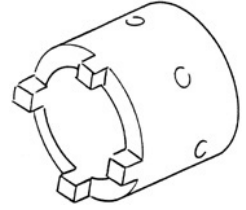

2. Remove the o-ring from the O-ring groove located inside the opening from which the seal was just removed.
3. Replace the o-ring with the o-ring supplied with the new main rod seal gland.
4. Taking care not to touch the seal material to any sharp rod features such as threads, slide the seal gland on to the actuator rod and to the face plate.
5. Using the appropriate gland and spanner wrench, tighten the seal to the proper torque level indicated in the previous table.

5.0 CLASS I DIVISION 2 OPTION

Class I division 2 products are provided with an electrical box containing terminal strips for customer wiring access. The electrical box has two ½-NPT ports for customer conduit connection. It is the responsibility of the installer to insure that the interconnecting wire, cabling and conduit meet any local or regional required electrical codes and standards.

Low Volt Terminal Block – Rockwell 1492-L3		High Volt Terminal Block – Rockwell 1492-L6	
Voltage Rating	600 VAC/DC	Voltage Rating	600 VAC/DC
Current Rating	27 Amps	Current Rating	50 Amps
Wire Gauge Range	26-12 AWG	Wire Gauge Range	20-8 AWG

5.1 Terminal Box Wiring Diagram

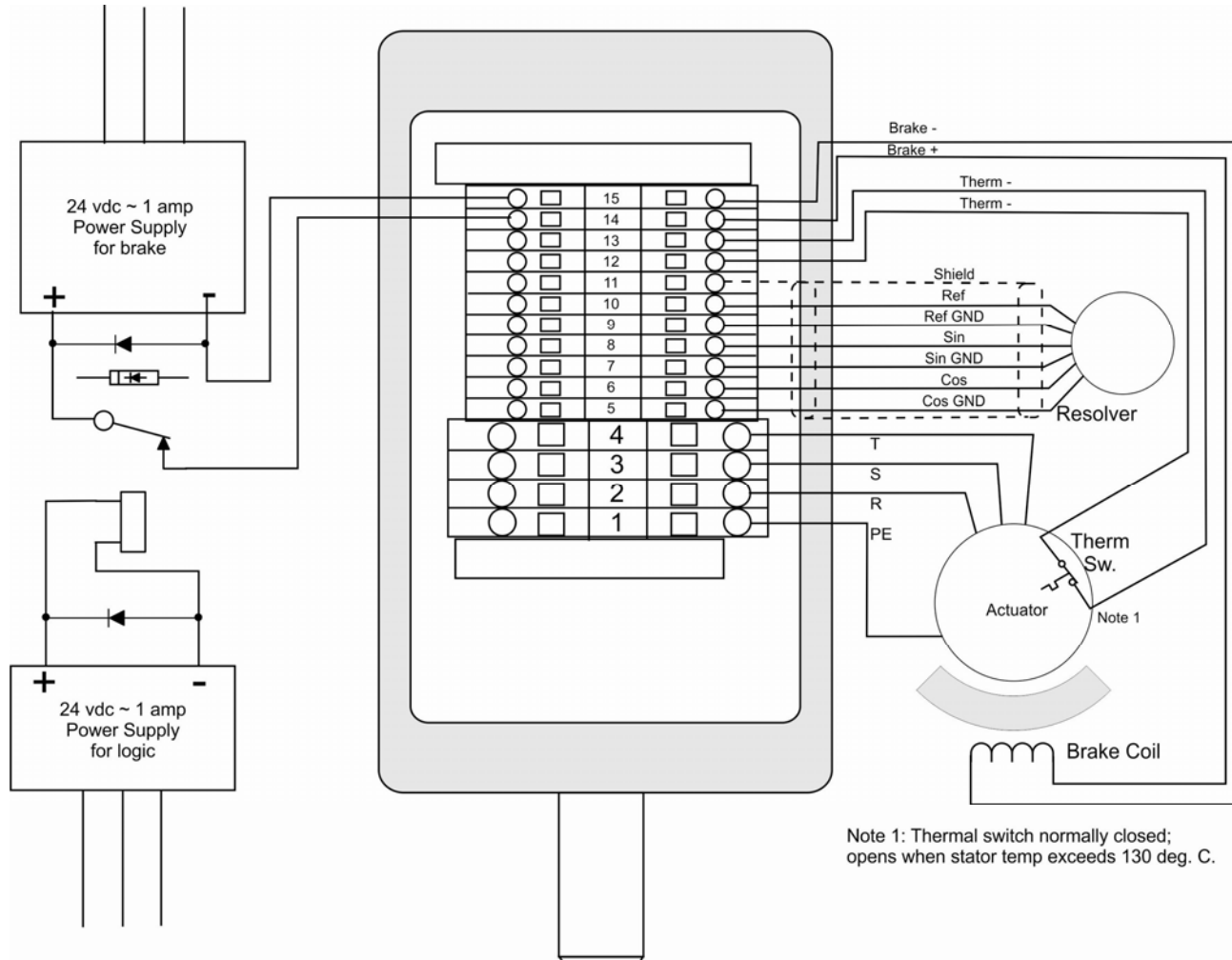

5.2 Class I Div 2 Terminal Box Terminations

Exlar uses spring clamp terminals for maximum vibration resistance and ease of connection

- Tin-plated terminals and stainless steel spring clamps for resistance to corrosion and vibration
- Spring clamp design to minimize stress relaxation and maintain contact force, even under vibration

To use spring clamp terminals:

1. Strip the wire to .5”(12-13 mm). Longer is better than shorter since you can always trim to fit.
2. Open the terminal by inserting a flat blade screwdriver into the spring release and slide wire in until it stops.



3. Make sure exposed wire is in the clamp, not insulated wire.

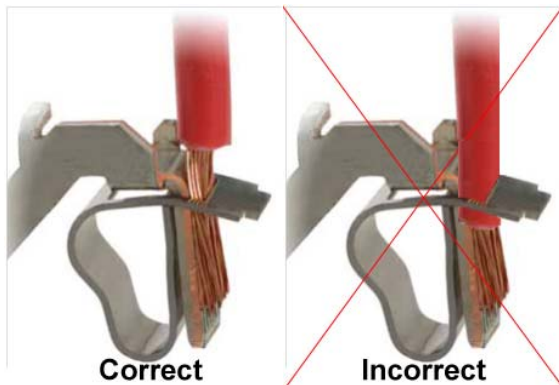

4. Remove the screwdriver. The clamp pressure will keep the wire in place. No exposed wire should protrude past the cage opening

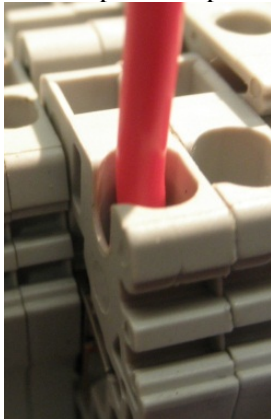

5.3 Terminal Box Dimensions

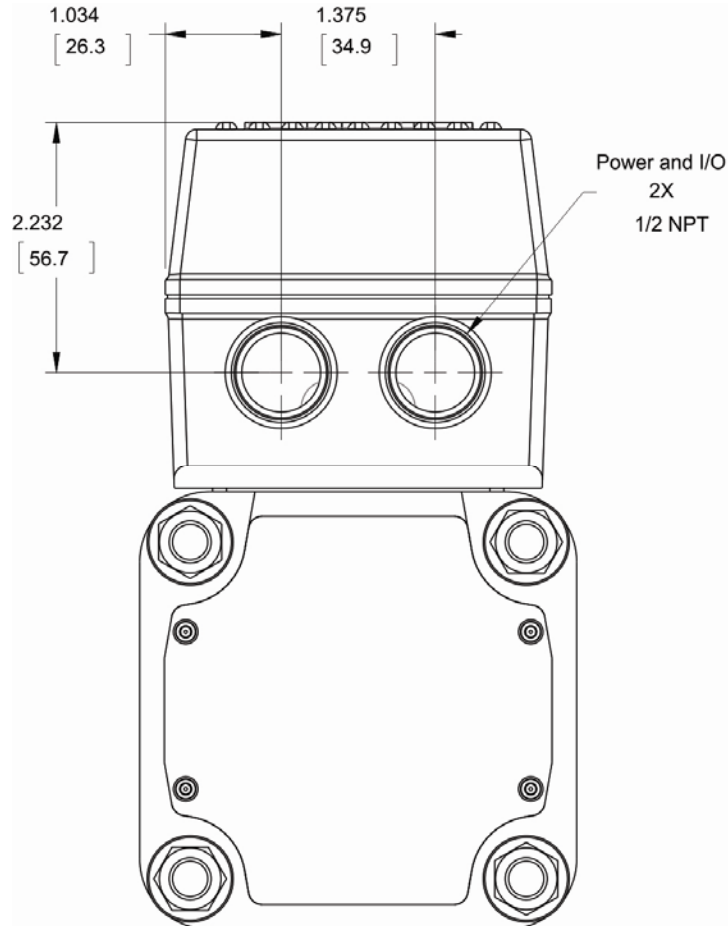

GSM30, GSM40

6.0 TROUBLESHOOTING PROCEDURES

This section provides you with guidelines and hints on troubleshooting various problems that may be encountered during installation and operation of your Exlar GSM Series actuator.

Symptom / Trouble	Possible Cause / Troubleshooting Procedure
No response from actuator.	<ol style="list-style-type: none"> 1. Check amplifier for faults that may indicate problem. 2. Check to insure that amplifier is enabled. 3. Check for proper wiring.
Actuator seems to be enabled (receiving current) but is not operating or is operating erratically.	<ol style="list-style-type: none"> 1. Amplifier may be improperly tuned. Check all gain settings. If a motor file or parameters specific to your amplifier/actuator combination have been supplied by Exlar, be sure that they are entered or downloaded properly. 2. Amplifier may be set up improperly for the particular motor being used. Check amplifier settings for number of poles, voltage, current, resistance, inductance, and inertia. 3. Feedback wiring may be incorrect. 4. Feedback conductors touching, or feedback cable may be damaged. 5. Motor phases are wired incorrectly or in incorrect order. (R,S,T) 6. Feedback (resolver or encoder) is improperly aligned. Contact Exlar.
Actuator cannot move load.	<ol style="list-style-type: none"> 1. Load is too large for the capacity of the actuator or too much friction is present. 2. Excessive side load. 3. Misalignment of output rod to load. 4. Amplifier has too low of current capacity or is limited to too low of current capacity.
Actuator housing moves or vibrates when shaft is in motion.	<ol style="list-style-type: none"> 1. Check actuator mounting. Insure that the actuator is securely mounted. 2. Amplifier is improperly tuned (wrong gain settings). Tune amplifier.
Output rod rotates during motion and thus does not provide proper linear motion.	<ol style="list-style-type: none"> 1. Install Exlar anti-rotation assembly or incorporate anti-rotation into the application.
Limit switches not functioning.	<ol style="list-style-type: none"> 1. Limit switches wired improperly. Refer to manual. 2. The device being driven by the limit switches is not compatible with the electrical output of the limit switch. Check device requirements. 3. Switches have been damaged by improper wiring or improper voltage applied. Replace switches.
Brake does not hold load in place.	<ol style="list-style-type: none"> 1. Load is larger than the capacity of the brake. <ul style="list-style-type: none"> -check load level against actuator rating. -oil lubricated units reduce holding capacity of the brake. 2. Brake is not engaged. (Power is not removed from brake) 3. Brake is being used as other than a power loss holding brake.
Actuator is overheating.	<ol style="list-style-type: none"> 1. Insufficient cooling for application requirements. See oil cooling section of this manual or Exlar catalog or contact Exlar engineering. 2. Actuator is being operated outside of continuous ratings. 3. Amplifier is poorly tuned causing excessive unnecessary current to be applied to motor. Check Gain settings.

6.1 Returning a Product for Repair

STANDARD REPAIR LEADTIME:

- Two weeks for written evaluation from Exlar
- Two weeks from receipt of approval (by fax or email) for repair where parts are available.
- An evaluation charge per unit after evaluation applies if customer chooses not to repair; or if product is found not in need of repair.

EXPEDITED REPAIR LEADTIME:

- An expedite charge per unit can be quoted.
- This provides one week for written evaluation from Exlar
- This provides one week from receipt of approval (by fax or email) for repair where parts are available.

PROCEDURE:

- Please discuss the return with Exlar Technical Support prior to requesting an RGA number to see if it is possible to resolve the issue prior to return.
- If it is determined that an RGA number is required, please do so by contacting the Returned Goods Administrator. Phone 952-500-6200 or email returns@exlar.com.
 - International Repairs: Closely follow instructions provided by the Exlar Returned Goods Administrator. Failure to comply with issued instructions may result in delays for repair and return.
- Exlar requires a purchase order at the time of RGA; \$0 on warranty returns, or for the standard evaluation charge per unit on all non-warranty units for the evaluation fee.
- Following the evaluation, you will receive a quote from Exlar on the charges that will apply. If the actuator repair is approved, the evaluation fee will be waived and we will request an amended PO for the actual repair value.

7.0 Certifications

Declaration of Conformity

*The undersigned, representing the
Manufacturer*

*and the authorized representative
established within the community.*

*Exlar Corporation
18400 West 77th Street
Chanhassen, MN 55317 USA*

*Exlar GmbH
Frankfurter Str. 107
65479 Raunheim, Germany*

declares, that the Exlar Brand products:

**GSX, GSM, SR, SLM, SLG Linear and Rotary Actuators
(Complete Model Listing Below)**

Model identification:

**GSX20, GSX30, GSX40, GSX50, GSX60,
GSX90, GSX115, SR21, SR31, SR41
SLM060, SLM090, SLM115, SLM142, SLM180
SLG060, SLG090, SLG115, GSM20, GSM30, GSM40**

*to which this declaration relates and are in conformity with the relevant EU
Directives listed below:*

**EU EMC Directive 2004/108/EC
EU Low Voltage Directive 2006/95/EC**

*using the relevant section of the following EU standards and other
normative documents:*

**EMC: EN 55014-1: 2006 + A1:2009
EN 55014-2: 1997 + A1: 2001 + A2: 2008**

Safety: EN 60034-1: 2004

Year of CE Marking: 2004

Manufacturer:

Signature: 
Name: Bill Zerull
Position: Chief Technology Officer
Date of Issue: 20-February-2012

Certificate of Compliance

Certificate Number 20111220 – E225288B
Report Reference E225288 – 2002 May 31
Issue Date 2011 December 20

Page 1 of 1



Issued to: EXLAR CORP
18400 W 77TH ST
CHANHASSEN, MN 55317 USA

This is to certify that representative samples of

Servo and Stepper Motors



Permanent Magnet servo motors, GSX or SR Series, Model GSM or GSX or SR; *followed by 20, 21, 30, 31, 40, 41, 50, 60, 90 or 115; followed by 01 through 24 or XX; followed by 01 through 99 or XX; followed by A, B, D, E, I, J, M, N, O, P, S, T or X; *followed by B, C, D, E, F, G, J, K, M, q, R, S, T, Z or X; followed by A, B, F, L, M, R, V, W or X; followed by three letters or numbers; followed by 1,2, 3 or X; followed by A, B, C, 1, 3, 5, 6 or X; followed by 6 or 8; may be followed by 01 through 99, AR, AS, AX, CF, EB, EN, ES, ET, FC, FF, FG, FM, FX, HB, HC, HW, L1, L2, L3, LT, MW, NI, P5, PB, *PF, RB, RD, SD, SR, SS, XH, XL, XM, N4, XT, XX; may be followed by 00000 through 99999.

Have been investigated by Underwriters Laboratories in accordance with the Standard(s) indicated on this Certificate.

Standard(s) for Safety: ANSI/UL 1004-1, "Rotating Electrical Machines - General Requirements" and CSA-C22.2 No. 100, "Motors and Generators."

Additional Information: See UL On-line Certification Directory at WWW.UL.COM for additional information.

Only those products bearing the UL Recognized Component Marks for the U.S. and Canada should be considered as being covered by UL's Recognition and Follow-Up Service and meeting the appropriate U.S. and Canadian requirements.

The UL Recognized Component Mark for the U.S. generally consists of the manufacturer's identification and catalog number, model number or other product designation as specified under "Marking" for the particular Recognition as published in the appropriate UL Directory. As a supplementary means of identifying products that have been produced under UL's Component Recognition Program, UL's Recognized Component Mark:  may be used in conjunction with the required Recognized Marks. The Recognized Component Mark is required when specified in the UL Directory preceding the recognitions or under "Markings" for the individual recognitions. The UL Recognized Component Mark for Canada consists of the UL Recognized Mark for Canada:  and the manufacturer's identification and catalog number, model number or other product designation as specified under "Marking" for the particular Recognition as published in the appropriate UL Directory.

Look for the UL Recognized Component Mark on the product

William R. Carney
Director, North American Certification Programs

Underwriters Laboratories Inc.

Any information and documentation involving UL Mark services are provided on behalf of Underwriters Laboratories Inc. (UL) or any authorized licensee of UL.

For questions, please contact a local UL Customer Service Representative at <http://www.ul.com/global/eng/pages/corporate/contactus>



Certificate of Compliance

Certificate: 2257566

Master Contract: 163694

Project: 2530873

Date Issued: August 9, 2012

Issued to: Exlar Corporation
18400 West 77th St
Chanhassen, MN 55317
USA
Attention: Gene Larson

The products listed below are eligible to bear the CSA Mark shown with adjacent indicators 'C' and 'US' for Canada and US or with adjacent indicator 'US' for US only or without either indicator for Canada only.



Ron Wachowicz

Issued by: Ron Wachowicz, C.E.T.

PRODUCTS

CLASS 3228 02 - VALVES - Actuators - For Hazardous Locations

CLASS 3228 82 - VALVES - Actuators - For Hazardous Locations-Certified to U.S. Standard

Class I, Division 2, Group A, B, C and D:

• GSX & GSM Series Linear Actuators and SLM & SLG Series Rotary Actuators, input rated 24Vdc, 48Vdc, 120Vdc, 115Vrms, 230Vrms, 400Vrms, 460Vrms or a Special Voltage Rating (not exceeding 460 Vrms), 50A max. Temperature Code T4 (135°C), $-50^{\circ}\text{C} \leq T_a \leq +65^{\circ}\text{C}$ (see note 2).

Model Code Information:

GSX/GSMxxx-xx Txx-aaa-xbx-xx-(xx..c..NI..xx)

aaa – resolver feedback

b - Voltage Rating

A = 24Vdc

B = 48Vdc

C = 120Vdc

1 = 115Vrms



Certificate: 2257566

Master Contract: 163694

Project: 2530873

Date Issued: August 9, 2012

3 = 230Vrms

5 = 400Vrms

6 = 460Vrms

X = Special Voltage Rating - Not to Exceed 460Vrms

c – Optional Mechanical and Speed Designations

HW = Hand-Wheel Switch

xx = denotes other options not affecting safety

x – denotes options not affecting safety

SLM/SLGxxx-xxx-xTxx-aaa-xbx-xx-(xx..c..NI..xx)

aaa – Resolver Feedback

b - Voltage Rating

A = 24Vdc

B = 48Vdc

C = 120Vdc

1 = 115Vrms

3 = 230Vrms

5 = 400Vrms

6 = 460Vrms

X = Special Voltage Rating - Not to Exceed 460Vrms

c – Optional Mechanical and Speed Designations

HW = Hand-Wheel Switch

xx = denotes other options not affecting safety

x – denotes options not affecting safety



Certificate: 2257566

Master Contract: 163694

Project: 2530873

Date Issued: August 9, 2012

Conditions of Certification

1. This Certification covers the actuator only. The end use suitability of the combination of the associated electronic controller and the actuator is to be determined by the local inspection authority having jurisdiction.
2. The actuators may include a hand-wheel switch (denoted by HW in Model Code). In such cases, the hand-wheel switch conduit must be sealed within 18 inches. When the handwheel option is included the maximum ambient temperature rating is $-20^{\circ}\text{C} \leq T_a \leq +40^{\circ}\text{C}$.
3. The actuators may include a holding brake. The thermal effects of the brake pad have not been evaluated and are to be considered by the authority having jurisdiction.

APPLICABLE REQUIREMENTS

CAN/CSA Standard C22.2 No. 0-10 (*Tenth Edition – September 2010*) - General Requirements - Canadian Electrical Code, Part II

CSA Standard C22.2 No. 0.4-04 (*October 2008 including updates No. 1 & 2*) - Bonding of Electrical Equipment

CSA Standard C22.2 No. 139-10 (*Third Edition, June 2010*) - Electrically Operated Valves

CSA Standard C22.2 No. 213-M1987 (*Reaffirmed 2008*) - Non-incendive Electrical Equipment for Use in Class I, Division 2 Hazardous Locations

UL Standard 429 (*Sixth Edition, Dated November 11, 2009*) - Electrically Operated Valves

ANSI/ISA-12.12.01-2007 - Nonincendive Electrical Equipment for Use in Class I and II, Division 2 and Class III, Division 1 and 2 Hazardous (Classified) Locations

MARKINGS

The markings are on a CSA Accepted Self-Adhesive Label material, e.g. CSA Accepted Brady B486 metallized polyester adhesive film label manufactured by Brady Worldwide Inc. Alternatively, permanent marking directly on the housing (ink, engraved, etched, etc).

- Manufacturer name: "Exlar, Corporation", "Exlar" or equivalent or the CSA Master Contract Number "163694" adjacent to the CSA Mark in lieu of the manufacturer name;
- Model number: as specified in the PRODUCTS section above;
- Manufacturing date in MMY format, or serial number, traceable to month of manufacture.
- Electrical ratings: as specified in the PRODUCTS section, above;
- Hazardous Location designation: as specified in the PRODUCTS section, above (may be abbreviated);
- Temperature code: as specified in the PRODUCTS section, above;
- Ambient temperature rating: as specified in the PRODUCTS section, above;



Certificate: 2257566

Master Contract: 163694

Project: 2530873

Date Issued: August 9, 2012

-
- The CSA Mark with or without "C" and "US" indicators, as shown on the Certificate of Compliance;
 - The words: "Warning: Explosion Hazard - Do not disconnect equipment unless power has been switched off or the area is known to be non-hazardous" or equivalent;
 - The words: "For Supply Connections, Use Wires Suitable for at Least 90°C (194°F)".

Note - Jurisdictions in Canada may require markings to be also in French. It is the responsibility of the Customer to provide bilingual marking, where applicable, in accordance with the requirements of the Provincial Regulatory Authorities. It is the responsibility of the Customer to determine this requirement and have bilingual wording added to the "Markings".