



Installation/Operation/Maintenance Manual and Reference Guide

VENTURION® Heater Models RV 225 RV 325



CSA Certified to Electrical and Fuel Burning requirements only.

IMPORTANT Notice to Owner and Installer

To ensure the long term benefits of burning your used oil in a Reznor® Used-Oil-Fired Heater, it is necessary to become familiar with the correct installation and maintenance of your new heater. Before installing or operating this heater, make sure you have read and understand this manual.

IMPROPER INSTALLATION OR LACK OF MAINTENANCE WILL VOID THE WARRANTY.

The most critical sections of this manual are

- Correct Draft Over Fire - Page 21
- General Maintenance Requirements - Page 24

As would apply to any gas or oil burner, without adequate draft over the fire, the combustion gases cannot escape resulting in an overheated combustion chamber. Even if the burner is installed correctly and adequate draft achieved, a flue passage blockage will affect the draft. Burning used oil is similar to burning wood. A fine gray ash accumulates in the chamber and flue passages. This accumulation of ash will eventually affect the draft. It is important to remove this ash before the draft is affected.

These topics are discussed in detail beginning on the pages listed above. Please familiarize yourself with these sections of your manual. Spending a few minutes to review this material will assure that you receive the return on investment that you expect from your heater.

Table of Contents

Installation.....	4-18	Heater Power Installation.....	18
Introduction.....	4	Main Power	18
Codes and Regulations	4	Pump Power Installation	18
Warranty.....	4	Heating Thermostat	18
Use.....	4	Heater Startup.....	19-23
Safety Warnings	5	System Check.....	19
Unpacking and Inspection.....	6	Check Test - Prior to Startup.....	19
Additional Parts.....	6	Burner Startup.....	19
Parts Carton.....	6	Heater Startup	20
Heater Placement	7	Check Test - After Startup	21
Minimum Clearances from		Heater Shutdown.....	23
Combustibles	7	Maintenance	24-33
High Altitude Installation	8	General Maintenance	
Fuel Tank, Pump, and Supply		Requirements	24
Lines	8	Maintenance Schedule	24
General Requirements.....	8	Maintenance Procedures.....	25
Fuel Tank.....	8	Service.....	34-35
Remote Fuel Pump.....	9	General Service	34
Supply Lines Installation.....	10	General Operation	34
Typical Installation	11	Troubleshooting	36-45
Mounting the Heater.....	12	Oil Burner Troubleshooting.....	36
General Requirements and		Troubleshooting Chart Guide	37
Weights.....	12	Location of Components.....	38
Suspension.....	12	Appendix	46-50
Mounting on an Optional Heater		Wiring Diagram 186251 for	
Stand.....	12	Model RV225	46
Venting the Heater.....	12	Wiring Diagram 186385 for	
Guidelines for the Vent System .	13	Model RV325	48
Detailed Requirements for the		Hour Meter / Cleaning Record....	50
Vent System	14	Index	51
Draft Regulator.....	15		
Heater Discharge	16		
Changing Discharge			
Configuration	16		
Optional Vertical Louvers.....	17		
Discharge Duct.....	17		

Installation

Introduction

Use

This heater is for commercial or industrial use only.

The heater should be installed by an experienced installer thoroughly trained and experienced with the installation of oil-fired appliances. The installer should be familiar with the special precautions necessary in the handling and storage of used automotive oils which may contain small amounts of gasoline.

Codes and Regulations

Installation must comply with:

In the United States

- The Standard for the Installation of Oil Burning Equipment NFPA 31
- The National Electrical Code NFPA 70
- Federal, State, and local municipal codes

In Canada

- CSA Standard B139-M91, Installation Code for Oil Burning Equipment
- CSA Standard C22.1-Canadian Electrical Code, Part 1
- Federal, Provincial, and local municipal codes
- Installation, operating and maintenance permits may be required from regulation authorities covering environmental quality, fuel, fire and electrical safety. Municipal permits may also be required.
- Regulation requires that only used oil generated on the premises of the owner may be burned in this equipment unless written authorization is obtained from the regulatory authority.

Warranty

For Warranty information, refer to the Limited Warranty form in the Literature Bag.

WARRANTY IS VOID IF

1. Heater is not installed in accordance with these instructions and applicable codes and ordinances.
2. Wiring is not in accordance with diagram furnished with the heater.
3. Heater is operated in presence of chlorinated vapors.
4. Air through the heater is not in accordance with the rating plate.
5. Heater is not maintained in accordance with maintenance requirements. **FAILURE TO CLEAN THE COMBUSTION CHAMBER ON A REGULAR BASIS WILL VOID THE WARRANTY.**
6. Other-than-specified fuel is burned.
7. Heater is operated at elevations greater than 3,000 ft above sea level without factory approved modifications.
8. Fuel input capacity is altered.

Safety Warnings



Conventions Used in this Manual

Hazard Intensity Levels

DANGER: Failure to comply will result in severe personal injury or death, and/or property damage.

WARNING: Failure to comply can result in severe personal injury or death and/or property damage.

CAUTION: Failure to comply could result in minor personal injury and/or property damage.

NOTE: Additional Warnings are also included throughout this manual.

Secondary Heat Source

CAUTION: These heaters are designed to provide economic disposal of used oils. Used oil is an inconsistent fuel and may contain water and/or foreign materials which may cause the unit to shut down. A secondary source of heat should always be provided to the building; do not depend on used oil as your only source of heat. This will prevent building damage should the heater become inoperable during subfreezing weather.

Fuels

WARNING

Approved fuels are No. 2 fuel oil and used automotive transmission fluid and crankcase oils up to 50 weight. Do not attempt to burn any grade of gasoline, paint thinner, or non-approved fluids. Adequate ventilation must be provided in any enclosure where storage tanks, pumps or accessories are installed.

Hazardous Atmosphere

This heater is not designed for use in hazardous atmospheres containing flammable vapors or combustible dust, or atmospheres containing chlorinated or halogenated hydrocarbons.

Venting

WARNING

Failure to provide proper venting could result in death, serious injury, and/or property damage. Units must be installed with a flue connection, draft regulator and proper vent to the outside of the building. Safe operation of any gravity vented heating equipment requires a properly operating vent system, correct provision for combustion air, and regular maintenance and inspection.

Safety Warnings Continued

Air for Combustion

WARNING

Care should be exercised to ensure that an adequate supply of combustion air is available and free to enter the air openings on all units. Room openings must equal one square inch per each 1,000 BTU heat input.

Non-Compliance

Failure to install or maintain this heater properly will void the warranty.

Unpacking and Inspection

Check the heater for any damage that may have occurred in shipment. If damage is found, document the damage with the transporting agency and contact an authorized Reznor Distributor. If you are an authorized Distributor, follow the FOB freight policy procedures as published by Reznor, LLCs.

Open the parts carton and verify receipt of all parts.

Additional Parts

Shipped with each heater is a remote fuel pump and a carton of parts. The carton contains parts required for installation. Before beginning actual installation, verify that the remote fuel pump and the parts listed below are at the installation site.

Parts Carton

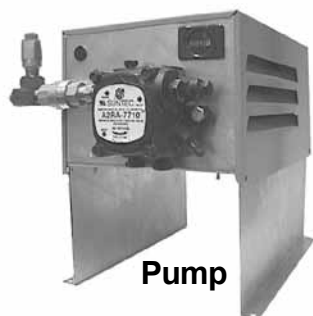

<u>Part No.</u>	<u>Code</u>	<u>Description</u>
255350	①	Thermostat
96388	②	Oil Filter
135986	③	Vacuum Gauge
110320	④	Foot Valve
130952	⑤	Oil Pump Inlet Manifold
37866	⑥	Draft Regulator
121030	⑦	Recycling Window Decal
121603	⑧	Warning label (for inlet to fuel storage system/tank)
136864	⑨	Foot Valve Strainer

Parts Carton

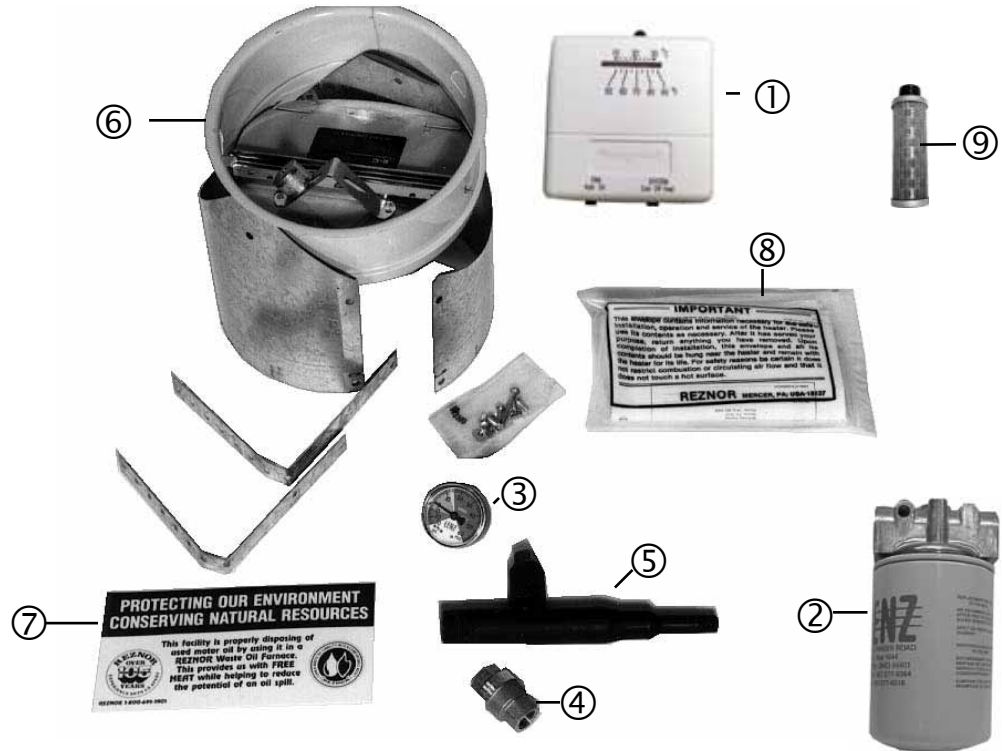

Heater Placement

Do not attempt to install this heater until you have read and understand this manual!

Placement is critical to the efficient operation of this heater.

Measure all distances to comply with the specific code requirements and minimum clearances listed on page 8.

Refer to the section on Venting for vent requirements and recommendations.

Locate the heater so that suitable means shall be provided to facilitate regular cleaning and maintenance of the heater (i.e. permanent platform, portable stairs, ladder, etc.).

Minimum Clearances from Combustibles

In Canada, for additional information on installation clearances, refer to CAN/CSA-B139-M91, "Installation Code for Oil Burning Equipment," Clause 7.0 - Installation Clearances.

WARNING

You must comply with all requirements on distance from heater to combustibles.

WARNING

Clearances apply to all combustibles. Do not leave paper, rags, or any moveable combustibles near the heater or store gasoline or any other flammable fluid near this appliance.

Model RV 225 and 325	Top	Rear	Bottom	Front	Sides	Flue Pipe
inches	3	6	0	48	18	18
mm	76	152	0	1219	457	457

High Altitude Installation

Standard Model RV used-oil-fired heaters are designed for use from sea level up to elevations of 3,000 ft. Without proper modifications severe overheating of the combustion chamber/heat exchanger will occur if installed above 3,000 ft. Also, the onboard air compressor will not deliver the correct amount of atomizing air to the fuel nozzle, resulting in poor combustion.

WARNING

Standard model used-oil-fired units installed above 3,000 ft elevation will overheat, damaging the heat exchanger assembly. Use of standard model heater above 5,000 ft may result in incomplete combustion and formation of carbon monoxide (CO). Failure to comply can result in severe personal injury or death and/or property damage and will void the warranty.

Check the rating plate for the approved elevations.

Models RV225

Elevation	Fuel Input		Heat Input		Heat Output	
	GPH	LPH	BTUH	kw	BTUH	kw
0-3,000 ft	1.43	6.5	200,000	58.6	160,000	46.8

Models RV325

Elevation	Fuel Input		Heat Input		Heat Output	
	GPH	LPH	BTUH	kw	BTUH	kw
0-3,000 ft	2.0	9.1	280,000	82.0	224,000	65.6

Fuel Tank, Pump, and Supply Lines

General Requirements

Model RV heaters are approved to burn used crankcase oil, transmission fluid, and No. 2 fuel oil. Maximum fuel input for a Model 225 is 1.43 GPH (6.5 L/H). Maximum fuel input for a Model 325 is 2.0 GPH (9.1 L/H). The oil supply tank and fuel lines must be installed in accordance with the National Board of Fire Underwriters requirements and all local ordinances. A UL-listed tank such as Reznor® Model OT-250 or equivalent must be used.

In the U.S., regulations require that storage tanks located inside buildings shall not exceed 275 gallons (1,041 L) individual capacity or 550 gallons (2,082 L) aggregate capacity in one building.

In Canada, regulations require storage tanks located inside buildings shall not exceed 550 gallons (2,082 L) individual capacity or 1,100 gallons (4,164 L) aggregate in one building.

Check with the local Fire Marshall to assure compliance with local ordinances and codes. **Installation of the tank and supply lines is the responsibility of the installer.**

Fuel Tank

CAUTION: It is recommended that used oil be at a temperature of 50°F or higher when it enters the pump. At a temperature below 50°F, oil becomes more viscous and difficult to pump. The heater may fire at a reduced rate and become erratic resulting in nuisance shutdowns.

Install either a UL listed Reznor® Model OT-250 oil supply tank or a field-supplied equivalent indoor storage tank.

- If installing a Model OT-250 tank, follow the installation requirements and instructions on the tank.
- If installing a field-supplied tank, follow the manufacturer's instructions.
- Height from the pump to the bottom of the heater should be no more than 15 ft (4.5 M). The used oil supply line requirements differ for Size 225 and Size 325.

Model RV225 must use 3/8" o.d. tubing in the oil supply line with a maximum length of 100 ft (30.5M).

Model RV325 should be a maximum of 60 ft (18M) in length when using 3/8" o.d. tubing or a maximum of 100 ft (30.5M) when using 1/2" o.d. tubing.

Although maximum height from the pump to the heater is 15 ft (4.5 M), we recommend that ease of service be considered when determining heater location. A service height of eight feet (2.5 M) is recommended. See the illustrations on pages 10 and 11 for examples of tank and line installation.

WARNINGS

Never pour gasoline or used oil containing gasoline into the supply tank. Adequate ventilation must be provided in any enclosures where storage tanks, pumps, or accessories are installed.

Remote Fuel Pump

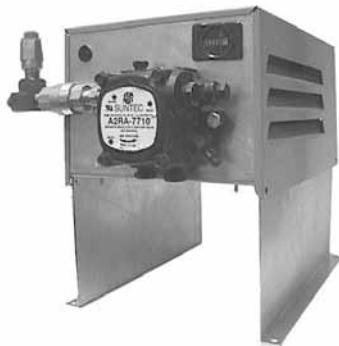

Pump

The Model OT-250 tank has a platform designed for attaching the remote fuel pump.

- Attach the fuel pump legs permanently either on the platform, directly to a field-supplied tank, or in a location very near to the oil tank.
- Mount the remote pump assembly in an upright, horizontal position as shown in the illustration.

NOTE: Do not mount the pump assembly in a vertical or inverted position.

NOTE: Appearance may not be exactly as illustrated but pump must be mounted as illustrated.

Fuel Tank, Pump, and Supply Lines (cont'd)

CAUTION: Do not use TEFLON based pipe dope or TEFLON tape to seal any pipe connections. Use of TEFLON based pipe dope or TEFLON tape will void the pump warranty.

Supply Lines Installation

Supply Lines

Read this section carefully before installing any supply lines. Since a suction line leak is nearly impossible to find, take your time to assure all connections are leak-free during installation. **Supply lines and fittings are furnished by the installer.** See the following illustration for minimum fittings required.

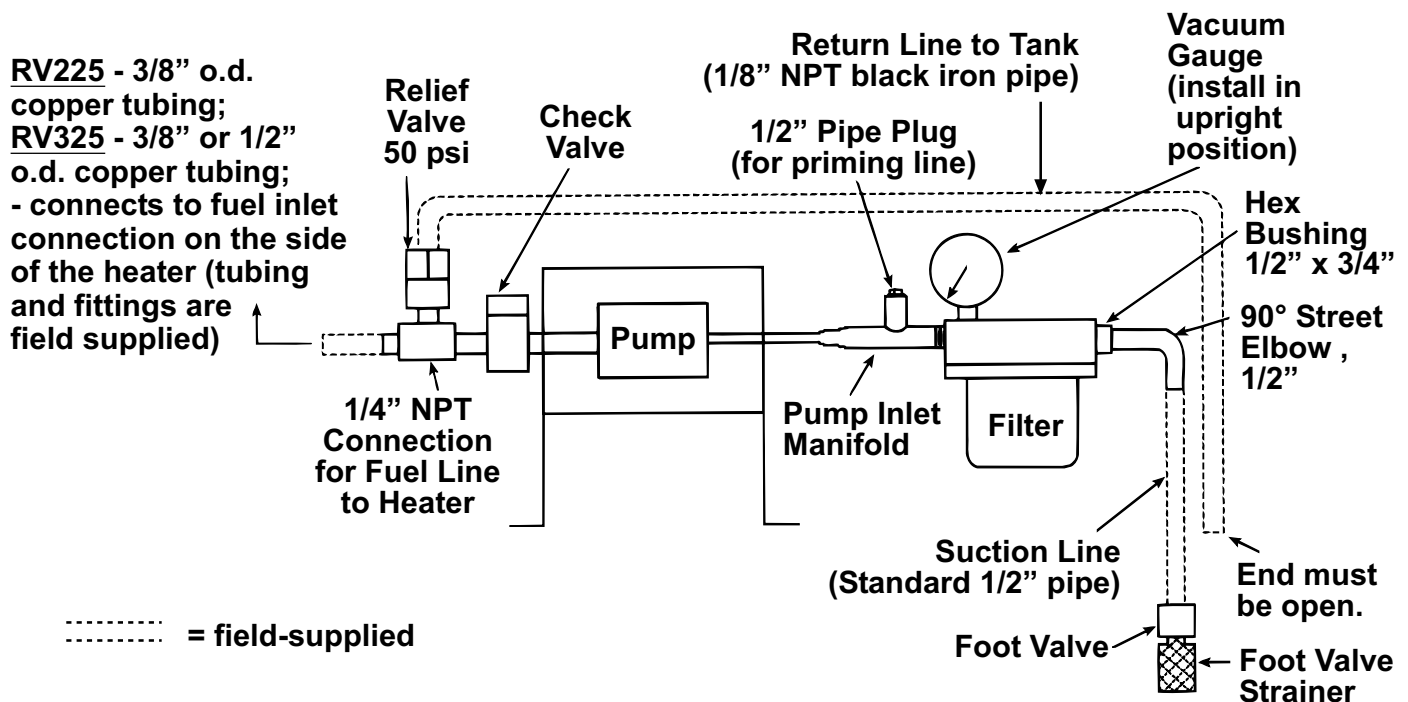

Suction Line (portion of supply line from foot valve to pump)

Run the suction line, using 1/2" standard black iron pipe, between the inlet side of the filter and the foot valve. (Refer to the illustration above.) A fuel line filter with a cleanable strainer, a foot valve, a foot valve strainer, and a vacuum gauge are provided with the heater. To prevent air from entering the line, do not use union connections in the suction line. Install the suction line components as illustrated. With the vacuum gauge mounted on the outlet side of the filter, the gauge will indicate any suction line restriction including a dirty filter. A pump inlet manifold is supplied for direct connection of the filter to the inlet of the pump.

Return Line

The 50 psi relief valve supplied with the pump and a return line of 1/8" NPT black iron pipe must be installed as illustrated.

**Discharge Line
(portion of supply
line from pump to
heater)**

The discharge line between the valve on the outlet side of the fuel pump and a Model RV225 heater should be 3/8" o.d. copper tubing with a minimum of 1/32" wall thickness with 45° flare fittings.

The discharge line between the valve on the outlet side of the fuel pump and a Model RV325 heater can be either 3/8" o.d. or 1/2" o.d. copper tubing with a minimum of 1/32" wall thickness with 45° flare fittings.

The discharge line must continually rise; a lift height of up to 15 ft (4.5 M) is acceptable. Maximum length varies by size of heater and size of tubing. Model RV225 must use 3/8" o.d. tubing in the oil supply line with a maximum length of 100 ft (30.5M). Model RV325 should be a maximum of 60 ft (18M) in length when using 3/8" o.d. tubing or a maximum of 100 ft (30.5M) when using 1/2" o.d. tubing.

**Supply Line
Connections and
Support**

Do not install manual valves in any part of the supply line.

Connection for the discharge line is on the side of the heater.

All piping should be protected from possible damage and be rigidly fastened in place in a workmanlike manner. Do not use TEFLON® based pipe dope or TEFLON® tape at the connections in an oil line. Use an oil-resistant pipe dope.

Do not use union connections in the suction line (line between the oil supply and the remote pump). **NOTE:** Care must be exercised to ensure air tight connections.

**Typical
Installation**

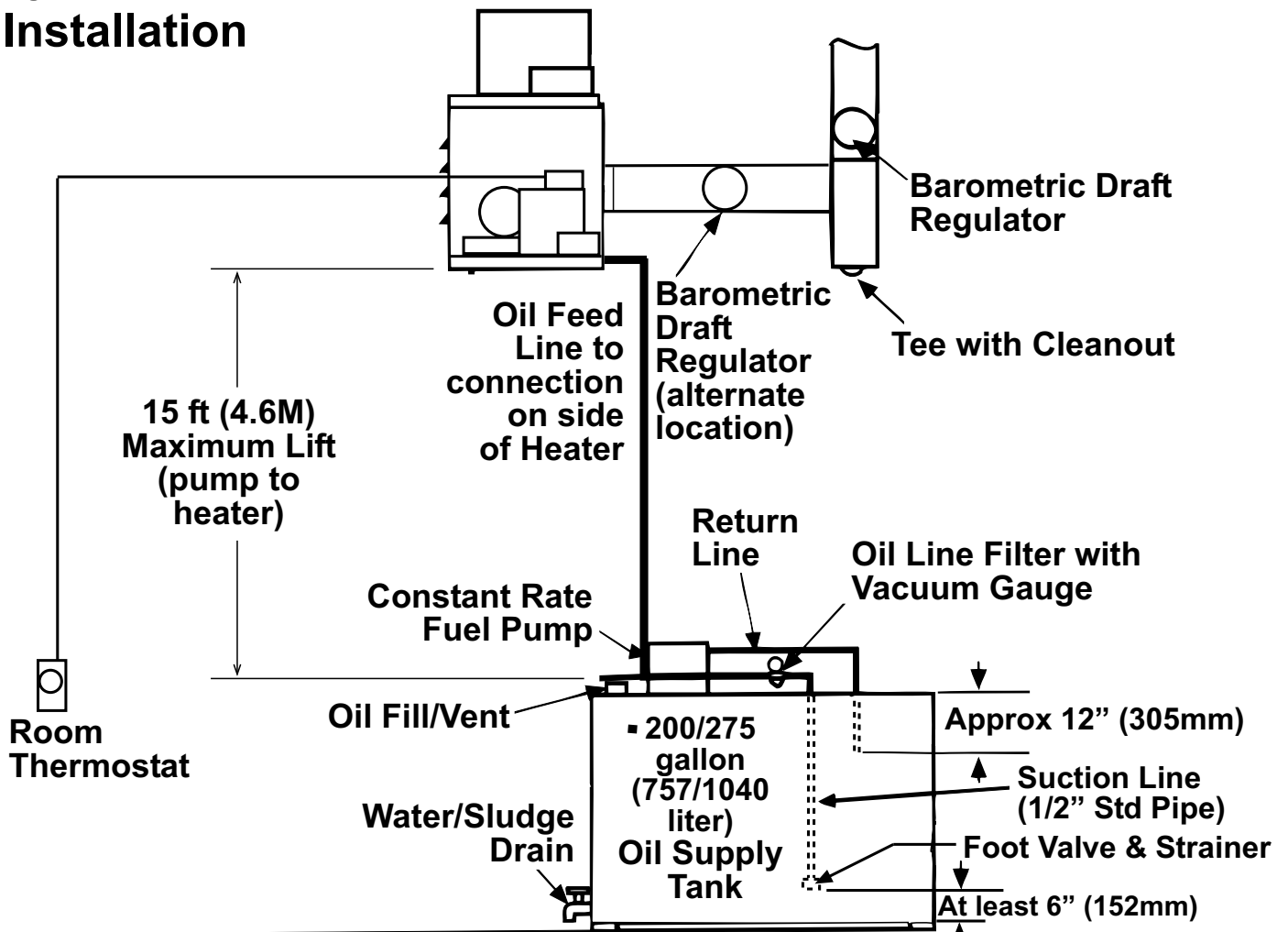

Mounting the Heater

General Requirements and Weights

Before suspending the unit, check the supporting structure to ensure it has sufficient load-carrying capacity to support the weight of the heater.

Model	Net Weight	
	lbs	kg
RV225	360	163
RV325	475	215

Use four 1/2"-13 diameter threaded rods. Lock each threaded rod using a washer and nut as shown in the illustration below. Or, use optional swivel connections (Option CK10) and field-provided 1" threaded pipe. Lock swivel connections as shown in the illustration.

Remove the shipping crate bottom from the unit. Remove the angle clips and re-insert the screws into the heater cabinet.

Suspension

WARNING

This heater must be supported level for proper operation. Do not place or add additional weight to the suspended heater.

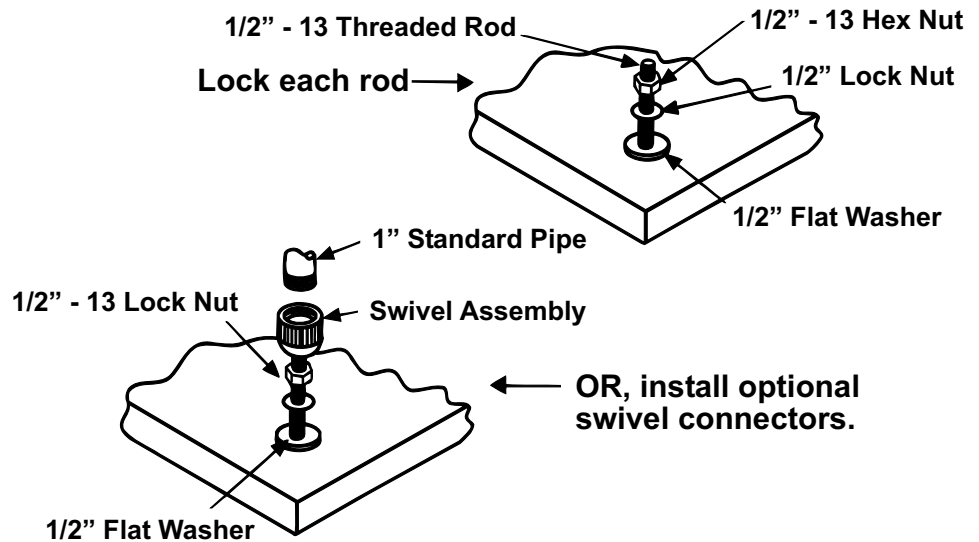

Mounting on an Optional Heater Stand

When accompanied with a Model OT Work Bench Fuel Tank (OT-250) and an Optional Heater Stand (Option HS-1), a Model RV heater may be mounted on the heater stand.

Follow the instructions packaged with the optional stand.

Venting the Heater

WARNING

Failure to provide proper venting could result in death, serious injury, and/or property damage. Units must be installed with a flue connection and proper vent to the outside of the building. Safe operation of any gravity vented heating equipment requires a properly operating vent system, correct provision for combustion air, and regular maintenance and inspection.

The vent system must comply with all local codes and in the event that local codes do not exist, the vent system must comply with a regional or national code.

The requirements for the vent system are dependent on (1) the location of the heater within a building and (2) the type of building.

Guidelines for the Vent System

- If the heater and the vent system are within the same heated space, single wall pipe may be used inside the building. The portion of the vent system outside the building must be a factory-built vent that is approved to Standard UL 641. See illustration.

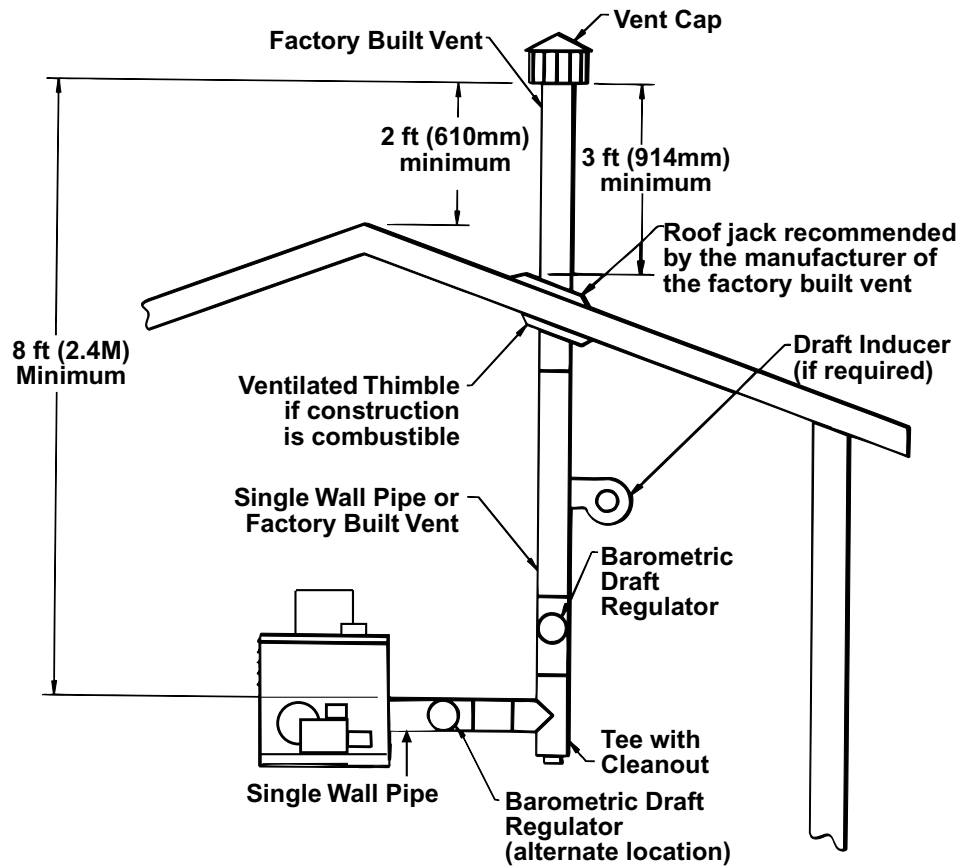

- Any portion of the vent system that passes through an unheated space or a concealed area such as an “attic” must be a factory-built vent that is approved to Standard UL 641. See illustration

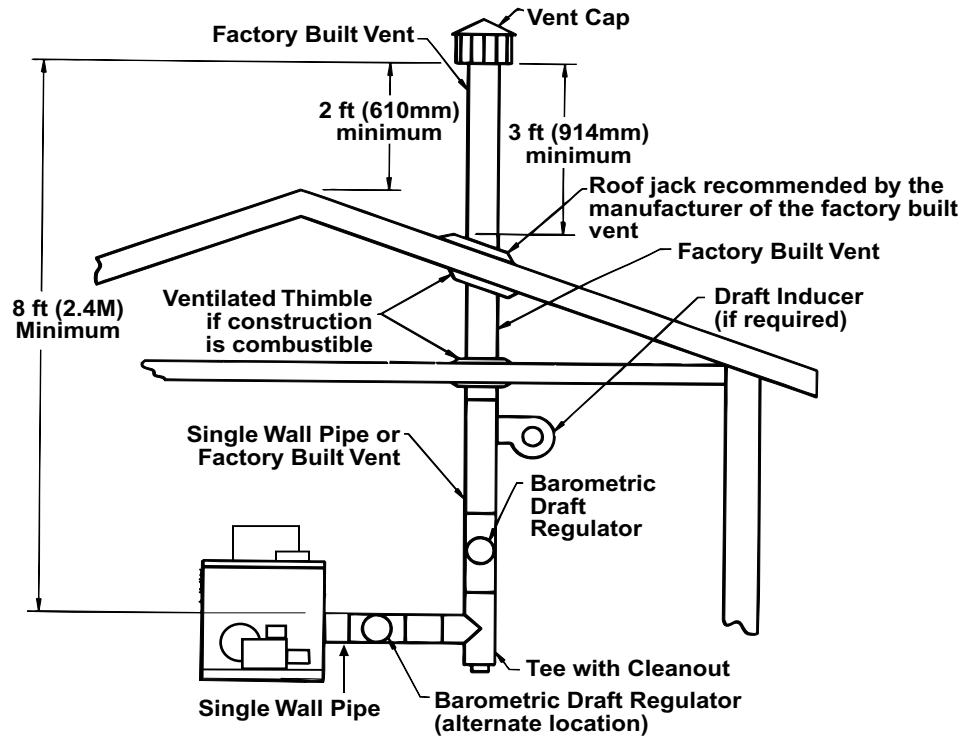

- The heater may be vented into a masonry chimney that complies with the BOCA National Mechanical Code for low-heat appliances or other building code requirements for low-heat appliances.

Venting the Heater (cont'd)

Detailed Requirements for the Vent System

(read all before beginning installation)

- **Pipe/Joints/Clearances:** Single-wall pipe must be a minimum of 24 gauge galvanized steel for 8" or 9" diameter pipe and 22 gauge for 10" or 12" diameter pipe. Each joint must be secured with three screws or rivets. If installing a factory-built vent, follow the manufacturer's instructions.

If the vent system passes through a combustible wall, material or roof, for single wall pipe, maintain 18" (457mm) clearance or install a ventilated thimble that is not less than 12" larger than the diameter of the vent pipe. If installing a factory-built vent, follow the manufacturer's instructions.

- **Horizontal Length and Slope:** The horizontal portion of the vent must comply with the maximum horizontal length shown in the table below and have not more than two elbows. Horizontal portions must be sloped upward 1/4" for each foot of pipe. If installation conditions require horizontal lengths in excess of those permitted in the table, a draft inducer must be used.

•Vent Pipe Diameter	Model Size and Vertical Length	Maximum Length of Horizontal Pipe
8"	225 with 8 feet (2.4M) or more of vertical pipe	Equal to or less than the vertical height
8"	325 with 10 feet (3M) of vertical pipe	Equal to or less than the vertical height
10"	325 with 8 feet (3M) of vertical pipe	Equal to or less than the vertical height

- **Vent Size:** The vent system must be at least 8" in diameter.
- **Barometric Draft Regulator:** A barometric draft regulator which is the same diameter as the vent pipe must be used, and it should be located close to the heater. See page 15. Do not install a manual damper or any other device that will obstruct the free flow of the flue gases.
- **Support:** The vent system must be adequately supported using non-combustible strapping or supports to carry the weight of the vent and wind load. Do not use the heater to provide support for the vent system.
- **Vertical Vent:** If installing a factory-built vent, follow the manufacturer's instructions.
If a masonry chimney is used, a thimble that is permanently cemented in place with high temperature cement should be used to permit easy cleaning of the chimney. The end of the vent pipe must not extend past the inside wall of the chimney.
- **Draft Inducer:** If a draft inducer is used, follow the manufacturer's instructions and wire the inducer according to the wiring diagram provided.
- **Terminal End:** The vent must terminate at least 3 ft (914mm) above the highest point of exit and at least 2 ft (610mm) higher than any portion of a building or obstruction within 10 ft (3M) of the chimney. Install a vent cap on the terminal end of the vent. A Reznor® Option CC1 vent cap is recommended. A different style of vent cap could cause nuisance problems.

Draft Regulator

A barometric draft regulator is shipped with this heater and **MUST** be installed in the flue near the heater flue opening. Refer to the illustrations on page 13 for recommended locations. To install, follow the manufacturer's instructions packaged with the draft regulator.

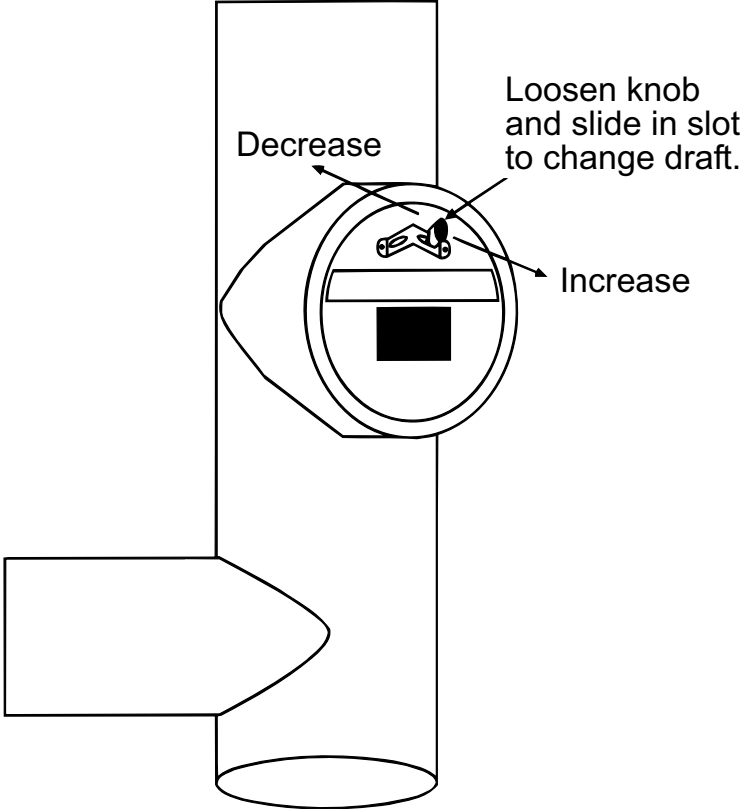

Heater Discharge

Changing Discharge Configuration

The heater is shipped from the factory with the louvered discharge in the front and solid panels in the rear as illustrated.

Discharge configuration can be changed so that all of the discharge is from the rear (Alternate 1) or so that the discharge is split between the front and rear (Alternate 2).

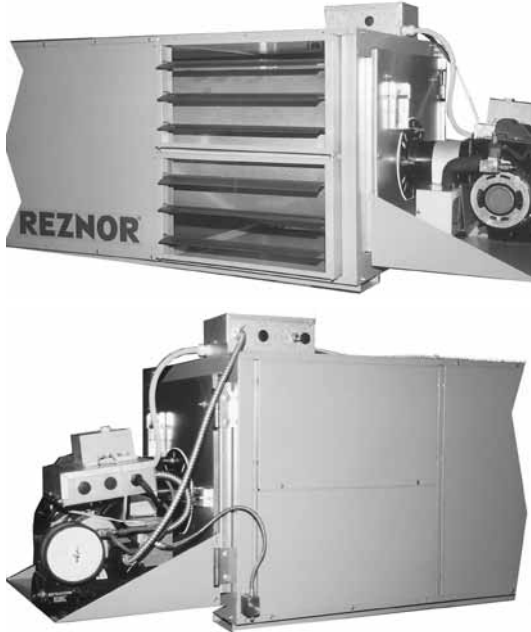

Discharge Configurations

FACTORY

Alternate 1

Alternate 2 (see illustration below)

FRONT

REAR

	FRONT	REAR
<u>FACTORY</u>	Full Size Discharge Opening with Louvers	Solid Panels
<u>Alternate 1</u>	Solid Panels	Full Size Discharge Opening with Louvers
<u>Alternate 2</u> (see illustration below)	Top Half Discharge Opening with Louvers	Top Half Discharge Opening with Louvers
	Bottom Half Solid Panel	Bottom Half Solid Panel

Configuration with discharge split between front and rear (Alternate 2 above)



Front



Rear

Instructions to Change to either of the Configurations Listed Above

IMPORTANT: Do not change the size of the discharge. The discharge must always be the same size; only the location can change.

Select the configuration and switch the locations of the louver frame and solid panels as needed.

1. Remove louvers individually. Push toward spring end; compress spring releasing other end; pull louver out of frame. Be careful not to lose the springs. The louver frame can be removed in one piece. Remove and save the screws that held the louver frame to the heater. Remove louver frame.

Alternate 1 - Remove both sets of louvers and their frames.

Alternate 2 - Remove only the bottom set of louvers and frame.

2. On the back of the heater, remove solid panel(s) saving the screws.

Alternate 1 - Remove both solid panels from the rear of the heater.

Alternate 2 - Remove the top solid panel from the rear of the heater.

3. Relocate the louver frame(s) and solid panel(s). Re-insert the louvers.

Alternate 1 - Install both louver frames and all the louvers in the opening on the back of the heater. Install the two solid panels in the front of the heater.

Alternate 2 - Install the louver frame and louvers in the opening on the top back of the heater. Install the solid panel removed from the back in the opening in the bottom front of the heater.

Optional Vertical Louvers

To widen the throw pattern, field installed vertical louvers are available for the front or rear discharge openings.

Follow the instructions in the option package to install the louvers.

Discharge Duct

A discharge duct **may be** attached to a Model RV heater. To connect the duct to the heater,

- Remove all louvers individually. To remove a louver, push the louver toward the end with the spring, releasing the opposite end. Slide louver out.
- Use the louver frame to attach discharge ductwork.

Duct Opening Dimensions

Duct Flange Outside Dimension	RV225		RV325	
	inches	mm	inches	mm
Height ("A")	21-7/16	545	26-7/16	672
1/2 Height ("A/2")	10-23/32	272	13-7/32	336
Width	19-3/16	487	19-3/16	487

IMPORTANT Never reduce the heater opening size abruptly. Always use a tapered transition like the one illustrated.

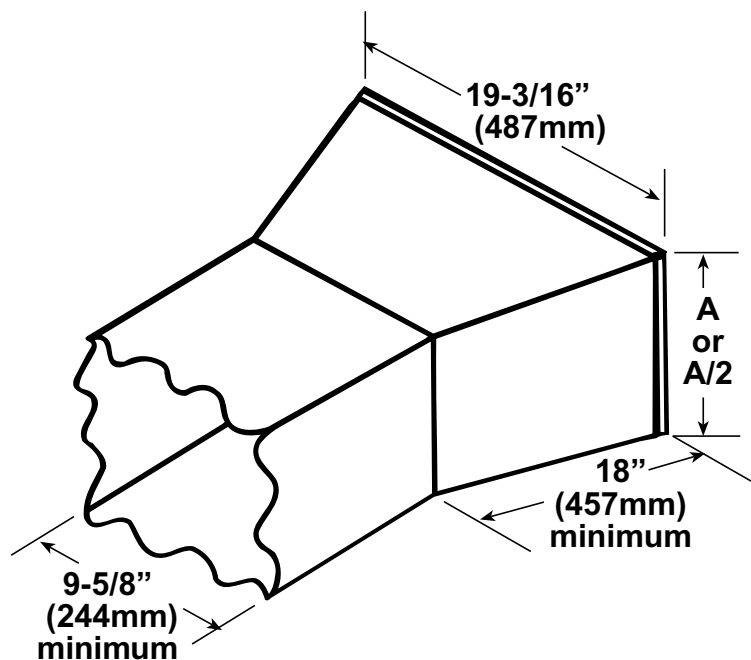

Heater Power Installation

Pump Power Installation

Main Power

DANGER

Make sure that the main circuit is OFF before making any wiring connections. All wiring must be done in accordance with appropriate Codes!

To connect the electrical power from the heater to the pump,

- Use a 3 conductor, 14 gauge wire system - two 115 volt conductors and a ground. Use BX if permitted, but make certain to follow local codes for running conduit.
- Refer to the wiring diagram for connecting terminals.

To install main power to the system (check the table below and the rating plate on the heater for current requirements),

- **Model RV225** - Use #10 gauge wire to run a dedicated 115 volt, single phase, line from the power source to a junction box mounted on the wall behind the heater or as required by appropriate codes.
 - Run the length of appropriate conduit from the heater to the junction box.
 - Connect the black wire to the hot lead.
 - Connect the white wire to the neutral lead.
 - Connect the green wire to the ground lead.
- **Model RV325** - Use #10 gauge wire to run a dedicated 230 volt, single phase 3 wire with ground line from the power source to a junction box mounted on the wall behind the heater or as required by appropriate codes.
 - Run the length of appropriate conduit from the heater to the junction box.
 - Connect the black wire to L1.
 - Connect the white wire to the neutral lead.
 - Connect the red wire to L2.
 - Connect the green wire to the ground lead.
- Install a fused manual reset, line voltage switch (field supplied) in this main line

• Electrical Ratings

Model	Total Current Amperes	Minimum Circuit Ampacity	Maximum Fuse Size Supply
RV225	19	24	30
RV325	20	26	30

Heating Thermostat

A 24-volt thermostat is furnished as standard equipment.

DO NOT attempt to wire relays or other accessories to the thermostat connections as these are not load terminals.

DO NOT install on or suspend the thermostat from the heater

DO NOT install thermostat on a cold outside wall

To install the thermostat,

- Locate the thermostat five feet above the floor on an inside wall, not in the path of warm or cold air currents nor in corners where air may be pocketed
- Remove the thermostat cover
- Make sure the heat anticipator dial is set at 0.2 amps
- Connect the wires through the back of the thermostat to the R & W terminals
- Set the ON/OFF switch on the heater electrical box to the "OFF" position and connect the thermostat wires to the two "T" terminals on the ignition controller.

Heater Startup

System Check

Follow the procedures listed in this section and complete the “Installation and Startup” form included in the Owner’s Envelope.

You should check your system completely before operating it.

Check Test - Prior to Startup

Check clearances from

combustibles. Be certain that the clearances are in compliance with the appropriate Codes.

Check hangers and supports. Be certain that all hangers and supports are adequately anchored and that all fittings are snug and do not rotate. Heater must be level.

Check to make sure all shipping supports have been removed.

Check the electrical supply. Be sure that all wire gauges are as recommended and that the supply voltage is as stated on the heater. Determine that fusing or circuit breakers are adequate for the load.

Check vents. Be sure that vent pipe and chimney meet the requirements and appropriate codes. A UL or CSA/UL listed draft regulator is required. A Reznor® (Option CC1) or Type L Breidert Air-X-hauster® vent cap is recommended. (Type L Air-X-hauster® is a trademark of The G. C. Breidert Company.)

Check the oil supply. Fill the supply tank to at least six inches from the top of the foot valve. NOTE: Always screen used oil with a 70-80 mesh strainer when filling the supply tank.

Burner Startup

Priming and Leak Check

For control locations,
refer to illustration on
page 38

Priming and Checking the System

The oil supply line to the heater must be full of oil and free of air for proper heater operation.

NOTE: Priming the oil line could take up to 30 minutes depending on the length of the line.

Follow the procedure below to prime the oil line.

1. Be sure the oil tank is filled to at least six inches above the top of the foot valve.
2. Remove the fill plug from the inlet manifold and slowly fill the suction line (line between the supply tank and the pump) with clean used oil. Fill slowly to allow air to escape. Replace the plug.
3. Locate the rubber tubing connecting the pressure switch in the main control box and the compressor.
 - Disconnect the tubing at the fitting on the compressor. This will prevent oil from flowing to the burner.
4. Remove the cad-cell wire from the F1-F2 terminals of the ignition controller.
 - Either attach a piece of tubing to the bleeder valve on the strainer tee (see page 26) on the burner assembly or place a container underneath to collect oil.
5. Turn the disconnect switch ON.

Observe the remote fuel pump motor to make certain it is running.

Priming and Leak Check Cont'd

For control locations, refer to illustration on page 38

Open the bleeder valve on the remote pump and wait until a full **flow of oil** is obtained without any air.

IMPORTANT NOTE: If continuous air bubbles are present, there is a suction line leak.

- Check the piping between the tank and the pump and correct the leak.
- Once a full flow of oil is present without any sign of air, close the bleeder valve on the remote pump.
- Observe the bleeder valve at the strainer tee and wait until a full flow of oil is obtained without any air.
- Tighten the bleeder valve on the strainer tee and remove the oil container.

6. Allow the pump to operate for several minutes.

Check the piping system for leaks at all connections.

Observe the return line to the tank - oil should be flowing.

Correct all leaks and re-test the system.

7. When the piping checks out as having no leaks, turn the disconnect switch OFF. Reconnect the rubber tubing to the compressor. In the electrical junction box, move the wire from the remote pump assembly from Terminal 1 back to Terminal 7.

8. Turn the disconnect switch ON and set the thermostat to a temperature above room temperature.

NOTE: On initial startup it will take approximately ten minutes to heat the oil. Once the oil is warm enough, the green light will come on and the unit will be ready to start. This delay only occurs on initial startup or when the disconnect switch has been turned off for an extended time.

You are now ready to start your system.

Heater Startup

Startup Procedure

After installing and testing your unit, follow the procedure below to start the system.

- Turn on the main electrical supply to the heater.
- Set the manual disconnect switch to the "ON" position.
- Set the thermostat to a temperature above room temperature.

NOTE: When the low oil temperature limit senses the proper oil temperature, the green light on the main control box will come on and the heater will fire.

A 10-minute delay may occur before firing depending on the system and the oil temperature. The delay only occurs on initial startup or after an electrical power interruption.

If the system does not automatically try to re-light, then the controller is in the "lockout" condition and must be reset by depressing the red button on the controller and holding it down for three seconds.

Once the system is purged of all air and oil reaches the nozzle, ignition will occur.

After Startup

Check Test - After Startup

- Check that there is sufficient draft for proper combustion. A negative draft of .01"-.02" w.c. is required in the combustion chamber over the fire.

NOTE: Draft measurements must be checked anytime there is a change in the air band setting.

Observation Door -

Remove plug; insert draft gauge into the port.



Instructions for Measuring Draft Over Fire:

- Remove the metal plug in the observation door.
- Insert draft gauge (such as Dwyer pressure gauge). Measurement must read at least a negative .01" w.c. to negative .02" w.c.
- If measurement is not as required, adjust draft regulator until measurement is within the proper limits (see page 15).
- Replace metal plug in the observation door.

WARNING

If there is insufficient draft, it will create a back pressure resulting in oil fumes in the building and/or pulsating when the burner starts and stops. It may cause excess deposits of soot and overheat the heat exchanger resulting in premature failure of the chamber. THIS TYPE OF FAILURE IS NOT COVERED UNDER THE WARRANTY.

To correct this problem, the height of the chimney may need increased and/or a UL or CSA/ULC listed draft inducer may be installed.

If a draft inducer is used, a draft proving switch must be installed to shut off the fuel supply to the burner in the event of the failure of the draft inducer.

CAUTION: If there is a backdraft or downdraft, do not continue operation of the heater until the situation is corrected. Equipment and/or property damage could result. Back pressure (backdraft or downdraft) may be caused by the chimney being lower than surrounding objects, such as buildings, hills, trees, rooftops, etc. It may be caused by an exhaust fan in the building. The air intake in the room where the heater is installed must be of sufficient size so that there is no change in the draft reading in the flue with the exhaust fan running.

Check-Test - After Startup (cont'd)

If there is too much draft, it could cause ignition problems, erratic burner, and loss of thermal efficiency. To correct this problem adjust the barometric damper to reduce the draft.

Check combustion air shutter and air band settings.

Certain installation conditions may necessitate a change in these settings. We recommend that the need for a change be determined by the use of instruments. When obtaining the CO₂ reading, do so with a hot system that has the correct draft settings. With a clean heat exchanger, these settings should result in a Bacharach smoke reading not greater than No. 1 and CO₂ reading in the range listed below.

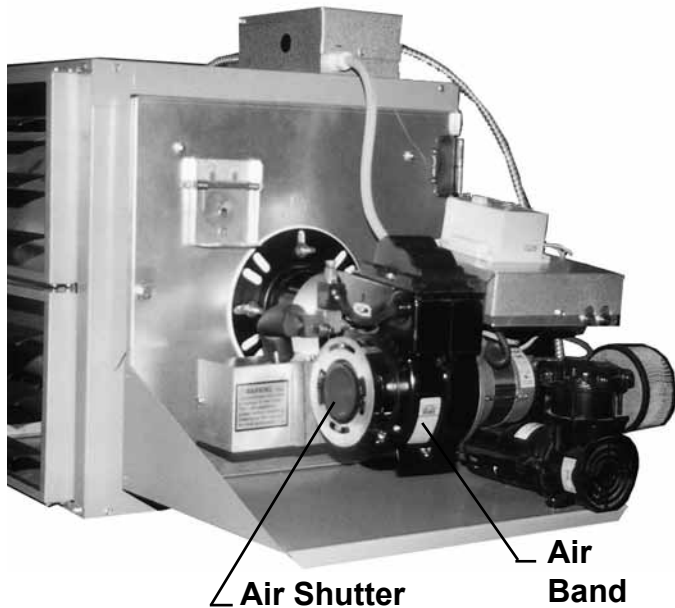

Reference Air Shutter and Air Band Settings			
Size	Air Shutter	Air Band	CO ₂ Range
225	#0	#2	11.0 - 11.5%
335	#0	#4	11.0 - 11.5%
These are settings from which a qualified serviceman/installer must make adjustments.			

IMPORTANT: If it is necessary to change the air band and air shutter settings, the draft measurement must be rechecked.

Check Discharge Air Temperature - Model RV with discharge ductwork only

Model RV225 - Model RV225 is designed for a maximum of .25" w.c. external static pressure AND for discharge air temperature rise from 60° to 70°F (16°-21°C).

Check the discharge temperature by placing a thermometer or thermocouple in the middle of the outlet or at the end of the discharge duct and measure the discharge air temperature after the heater has operated for at least 20 minutes. If the temperature rise is not within the allowable range, alter the ductwork to achieve the correct temperature rise.

Model RV325 - Model RV325 is designed for a maximum of .50" w.c. external static pressure AND for discharge air temperature rise from 60° to 70°F (16°-21°C).

Check the discharge temperature by placing a thermometer or thermocouple in the middle of the outlet or at the end of the discharge duct and measure the discharge air temperature after the heater has operated for at least 20 minutes. If the temperature rise is not within the specified range, adjust the blower speed (follow instructions below) or alter the ductwork to achieve the correct temperature rise.

Check the blower motor amp rating. If the blower motor maximum amp rating is exceeded, alter the ductwork to reduce the static pressure (resistance of the air flow).

Adjust Blower Speed

Follow these instructions to adjust blower speed.

1. Turn off the electrical power.
2. Loosen belt tension and remove belt.
3. Loosen the set screw on the side of the pulley away from the motor.
To increase blower speed, decreasing outlet temperature
 - Turn the adjustable half of the pulley inward.To decrease blower speed, increasing outlet temperature
 - Turn the adjustable half of the pulley outward.One turn of the pulley will change the speed 8-10%.
Tighten the set screw on the flat portion of the pulley shaft.
4. Replace the belt and adjust the belt tension. Belt tension is adjusted by means of the adjusting screw on the motor base. Adjust until the belt can be depressed 1/2-3/4". Tighten the lock nut on the adjusting screw.
5. Turn on the electric power.
6. Start the heater by turning the thermostat to a setting higher than room temperature.
7. Check motor amps with an amp meter. The maximum motor amp rating on the motor nameplate must not be exceeded.

CAUTION: An external duct system static pressure not within the limitation on the heater rating plate and/or improper adjustment of the motor pulley or belt may overload the motor or cause overheating of the heat exchanger.

- While the pump is running, record the vacuum gauge reading and post it on or near the remote pump assembly.
The maximum allowable vacuum rise is 10" Hg. (Example: With a new oil filter, if the vacuum gauge indicates a suction line vacuum of 3" Hg, the maximum allowable gauge reading is 13" Hg.) The vacuum gauge should never exceed 15" Hg.
- Display self-adhesive "Used Oil Recycling" decal on entry door or window.
- Adhere tank warning label at location visible when filling the tank or at a point where fuel is first introduced to a transfer piping system.
- Complete the information on page 52. Return all instruction manuals to the "Literature Bag" and give them to the owner to keep for future reference.

Heater Shutdown

At the end of the heating season or any time the heater will be shutdown for a long period of time, turn off the power.

Clean the heat exchanger/combustion chamber and flue pipe. Perform other maintenance procedures either at shutdown or before re-starting the heater.

Maintenance

General Maintenance Requirements

Maintenance Schedule

WARNING

Turn off electric power to the heater before doing any service or maintenance on the heater.

When burning used automotive diesel engine and truck oils, this heater will require more frequent service than conventional heating equipment. All used oils contain a small amount of ash. This ash is similar in texture to that found in wood burning fireplaces, and varies with the types of oil used. **FAILURE TO REMOVE THIS ASH ON A REGULAR BASIS WILL VOID THE WARRANTY.**

Do not let your oil supply tank run out of fuel. Check the oil level in the supply tank daily to be certain an adequate supply is available. Running out of fuel oil will require you to re-prime the system.

The following are starting points for tailoring a maintenance schedule to fit the application. When performing the maintenance procedures listed below, note the hours on the hour meter. After one or two cleanings, the maintenance schedule may be altered based on the hours of operation. However, if there is a major change in the type of used oil being burned, maintenance requirements can be affected. Any time there is a major change in fuel, return to the schedule listed below and note the hour meter readings to re-tailor the maintenance schedule.

At the end of the heating season or whenever the heater will be shut down for a long period, always turn off the power. Clean the heat exchanger/combustion chamber and the flue pipe. Before restarting, perform all maintenance checks.

Weekly:

- Check the vacuum gauge on the filter for an indication that the oil line filter needs replaced and/or motor pump screen needs cleaning. The maximum vacuum rise is 10" Hg; the maximum reading is 15" Hg. Follow instructions on pages 25 and 26.

Monthly:

- Inspect the combustion chamber/heat exchanger and flue. If needed, clean the combustion chamber/heat exchanger and flue. Follow the instructions on pages 27 and 28.

Record the hour meter reading for future reference. A Maintenance Record Chart is provided in the Appendix for this record.

WARNING

When inspecting and cleaning the combustion chamber/heat exchanger and flue, wear protective clothing, including gloves and a face mask or respirator. Dispose of ash properly. Read the warning statement on cleaning the combustion chamber.

- Drain water from the bottom of the supply tank until a steady stream of oil is obtained.

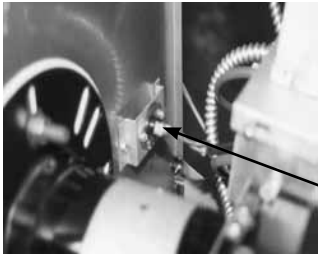

**Backflow/Ash
Sensor Switch**

- Clean the backflow/ash sensor switch. Remove any soot from the sensor. Check the electrical connections.

Every Six months:

- Clean the oil strainer at the burner. See page 25.
- Clean the foot valve screen. See illustration on page 10.
- Replace the air filter. See page 29.
- Clean the end cone. See pages 29-30.
- Replace the oil nozzle. See page 29.
- Clean the external surfaces of the combustion chamber/heat exchanger. See page 33.
- Clean the blower. See page 33.
- Check for oil leaks.
- Check blower belt for tension and wear. See page 27.
- Inspect the electrodes. See pages 29-30.
- Clean the pre-heater. See page 32.

NOTE: A maintenance record chart is provided in the Appendix.

Maintenance Procedures

Replace the Supply Line Filter and Clean Internal Pump Screen

Replacing the supply line filter, cleaning the foot filter, and cleaning the pump screen require breaking the suction line. The suction line is the portion of the supply line from the tank to the remote pump. If air leaks develop in the suction line, the heater will not operate properly.

Follow all instructions, including “Recharging the Suction Line,” (page 26) to avoid creating an air leak.

Replacing the Supply Line Filter



1. Remove the old filter canister.

- Carefully unscrew and remove the filter canister. Dispose of properly.

2. Replace the filter canister.

- Attach a replacement filter canister, P/N 176535.

Cleaning the Internal Pump Screen

1. Check the Screen

- Disconnect the inlet oil line from the pump.
- Using a flashlight, look into the pump inlet.
 - a) If the portion of screen visible at the inlet appears to be clogged, go to Step 2.
 - b) If the screen appears unclogged, reconnect the inlet line making sure that the connection is tight. Do not remove the pump cover. Go to the instructions for “Recharging the Suction Line” (below).

2. Remove and Clean the Screen

- To access the screen, the pump cover must be removed.
- Remove the four bolts that hold the pump cover. (Be careful, pump is full of oil).

Cleaning the Pump Cont'd

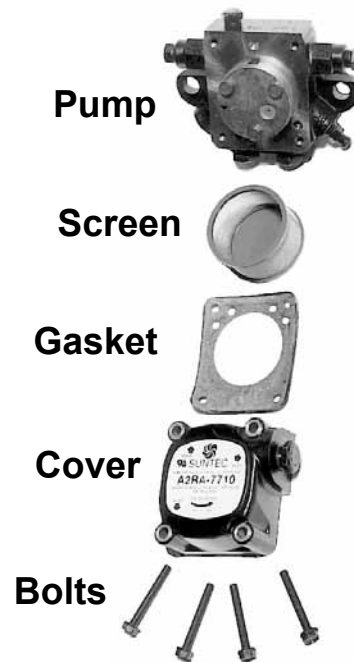

- Remove the cover being careful not to lose or damage the gasket.
- Remove the circular screen and clean with a solvent and compressed air.

NOTE: If the screen is damaged during cleaning, replace it with Reznor P/N 123450.

3. Reassemble the pump

- Check the gasket and if a replacement is needed, replace it with Reznor P/N 123451.
- Re-assemble the pump and reconnect the inlet oil line being sure that the connection is tight.

Recharging the Suction Line

- 1) Remove the fill plug from the inlet manifold and slowly fill the suction line with oil (allow time for air to escape).
- 2) Replace the plug.
- 3) Check vacuum gauge connections and filter housing to be sure that everything is tight. The suction line must be full of oil and all connections tight for the heater to operate properly.

NOTE: Refer to the section, "Priming and Leak check" (starting on page 19) for check list and instructions.

Cleaning the Burner Oil Strainer

Instructions for cleaning the burner oil strainer:

- 1) Identify the strainer tee located in the fuel line just upstream from the burner.
- 2) Remove the hex nut from the end of the strainer tee, being careful not to lose the "O" ring.
- 3) Remove the spring and strainer from the inside of the tee. Clean by washing both the spring and screen with a solvent.

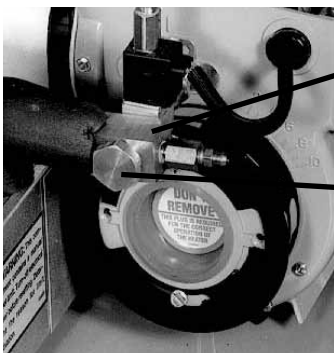

Oil Strainer Tee

Remove Hex Nut, Strainer Screen & Spring

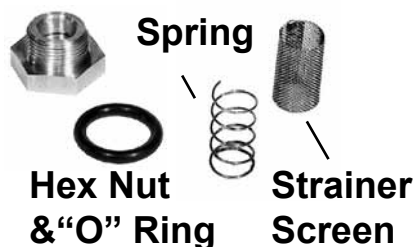

- 4) Reinsert the cleaned screen and spring into the tee. With the "O" ring in place, re-attach the hex nut.

Inspect Belt

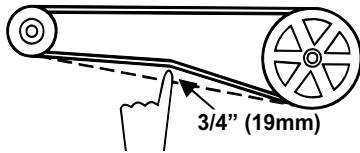

Inspecting and Cleaning Combustion Chamber/Heat Exchanger and Flue Pipe

Inspection

Remove the belt guard and check the belt tension. Belt should be able to be depressed 1/2-3/4". If the belt does not have proper tension, adjust with the adjusting screw on the motor base. If the belt shows signs of wear, replace with the proper size belt.

Always re-attach the belt guard.

WARNING

Used oils may contain engine-wear metal compounds and foreign materials. When burned, these compounds are deposited within or exhausted from this heater. Therefore, care should be taken when using, cleaning and maintaining this equipment.

Whenever any cleaning including the flue pipe and exhaust stack is done, proper protective equipment, including gloves and a face mask or respirator, must be worn.

WARNING

Turn off electric power before inspecting or cleaning the unit. Allow unit to cool.

To determine need for cleaning, inspect the combustion chamber/heat exchanger through the access door on the end of the heater opposite the burner.

- 1) Remove the door panel by lifting upward and outward on the door handle.
- 2) Using a 1/2" wrench, remove the nuts and washers from the inner door.
- 3) Pull the door directly off the studs.
- 4) Shine a flashlight into the chamber.
- 5) If ash buildup is to the bottom of the flue restrictor, leave covers off and proceed with cleaning.



Heat Exchanger/
Combustion Chamber
Outer Access Door

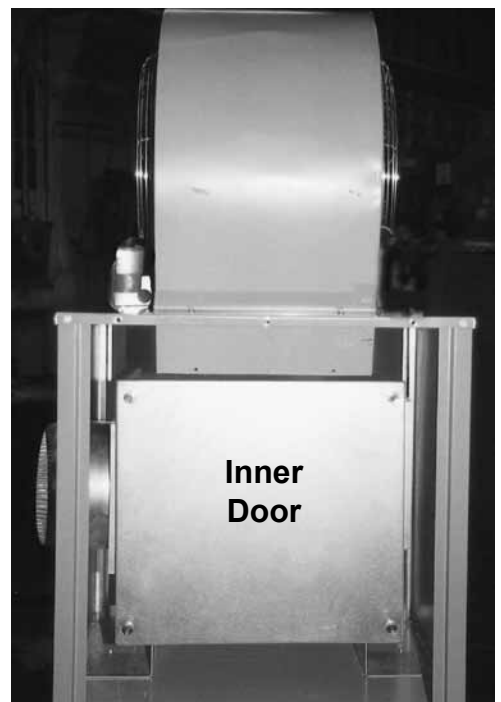

Inner
Door

Maintenance Continued

Inspecting and Cleaning the Heat Exchanger/ Combustion Chamber (cont'd)

View with Inner Access Door Removed

If ash buildup is to the bottom of the flue restrictor, leave covers off and proceed with cleaning.

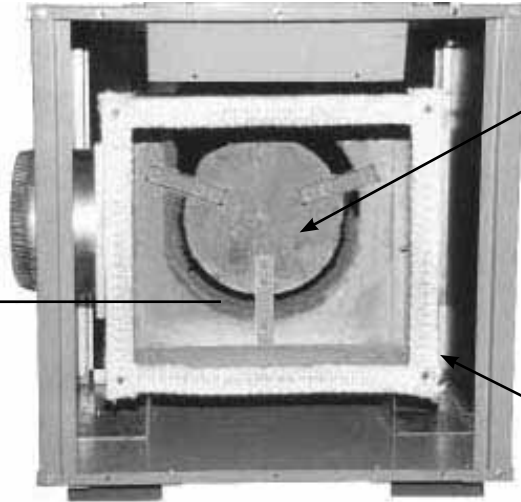

Flue Restrictor - a cylinder that slides into the chamber about 15" (381mm)

NOTE: Current improved design appears slightly different including a handle for easier removal.

Inspect Gaskets - If gaskets need replaced, use material identical to the original equipment.

Remove Soot and Ash from the Combustion Chamber/ Heat Exchanger and the Flue Pipe

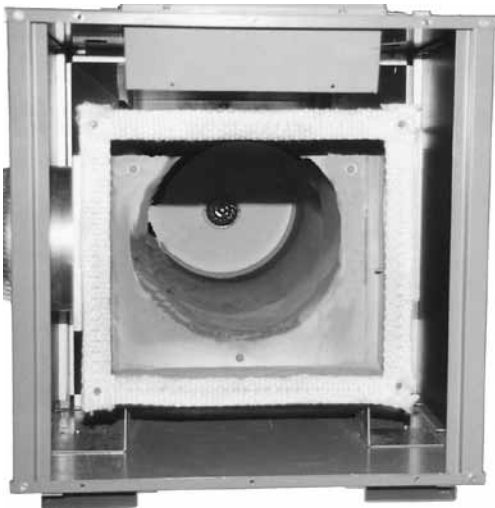

Clean Heat Exchanger/ Combustion Chamber and Flue Pipe

1. Remove the Flue Restrictor

Illustrated above, the restrictor is a cylinder that extends into the chamber about 15 inches (381mm).

- Remove the three brass nuts securing the restrictor.
- Pull the restrictor off the studs and out of the chamber.

2. Clean the heat exchanger/combustion chamber and the flue pipe.

- Use a stiff brush.
- Remove ash with a shop vacuum.

WARNING

The ash that is removed from this heater may contain heavy metal compounds that are environmentally undesirable and should be disposed of in a conscientious manner.

3. Check Gaskets

- Check access panel gaskets. If replacement gaskets are needed, use gasket material identical to the original equipment.

4. Re-assemble

Replacing the Compressed Air Filter

Locate the compressed air filter.

- 1) Remove the wing nut, the cover plate, and the filter.
- 2) Properly discard the old filter and replace with a new filter (Reznor P/N 107216, Wix Filter No. 43274, or NAPA No. 2374).
- 3) Fasten with cover and wing nut.



Compressed Air Filter

Accessing the Burner and Cleaning End Cone, Nozzle, and Electrodes

WARNING

Turn off the electric power before burner is serviced.

1. Access Burner

- Locate the yellow wiring cable that goes from the electrical box on the top of the heater to the burner junction box. Disconnect the cable at the connection as it exits the top electrical box.
- Remove the two bolts from the opening side of the door.
- Open the hinged door. The end cone of the burner is visible.

2. Remove/Clean the End Cone

- Remove the screws that hold the end cone to the burner tube.
- Remove and clean the end cone using a stiff wire brush.
- Check the end cone for deterioration and replace if deterioration exists.

3. Remove the Nozzle (requires both a 1" and a 5/8" open-end wrench)

- To prevent the fuel line assembly from twisting, use a 1" open-end wrench to hold the nozzle adapter while removing the nozzle with a 5/8" open-end wrench.
- Clean nozzle by disassembling, washing thoroughly, and blowing dry with compressed air.
- If nozzle face appears worn, replace the oil nozzle (RV225, P/N 129382; RV325, P/N 102997). Annual nozzle replacement is recommended. This nozzle is custom designed. **Do not substitute nozzle.**
- Replace the end cone.

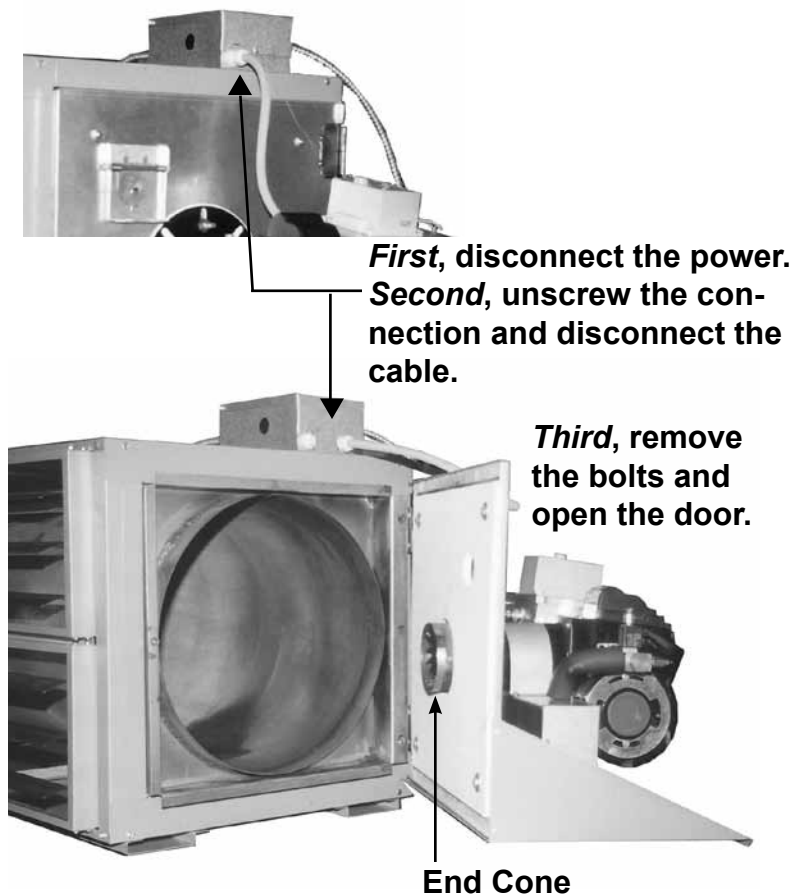

Maintenance Continued

Accessing the Burner and Cleaning End Cone, Nozzle, and Electrodes (cont'd)

NOTE: Be sure NOT to damage the “O” ring on the nozzle. If the “O” ring appears damaged, replace the nozzle and the “O” ring.

4. Inspect the Electrodes

- The electrode porcelain insulators must be free from carbon, oil, dirt, pinhole leaks, cracks, moisture and evidence of over-the-surface arc tracking. Otherwise, short circuiting could cause ignition problems. If any of these conditions exist, replace with new porcelain insulators, kit (P/N 269820).
- If a need for service or replacement is determined, see instructions on page 31.

5. Reassemble

- Check the door gasket. If damaged, replace with like replacement.
- Close the door and fasten with the bolts, nuts, and washers.
- Re-connect the yellow wire cable.

Remove Fuel Line Assembly to Service Controls and Spark Electrodes (Alternate method for servicing nozzle)



Escutcheon Plate

WARNING

Turn off the electric power before removing the fuel line assembly.

NOTE: In order to service the fuel line assembly controls and spark electrodes, it is necessary to remove the fuel line assembly.

Removing the Fuel Line Assembly

1. Loosen the connection nut one or two turns.
2. Disconnect the fuel connection assembly by loosening the 5/16” inverted flare fitting. Do not change the position of the escutcheon plate.
 - Pull the fuel connection assembly clear of the burner housing.
3. Loosen the two transformer holddown screws.
 - Lift the hinged transformer to its open position.

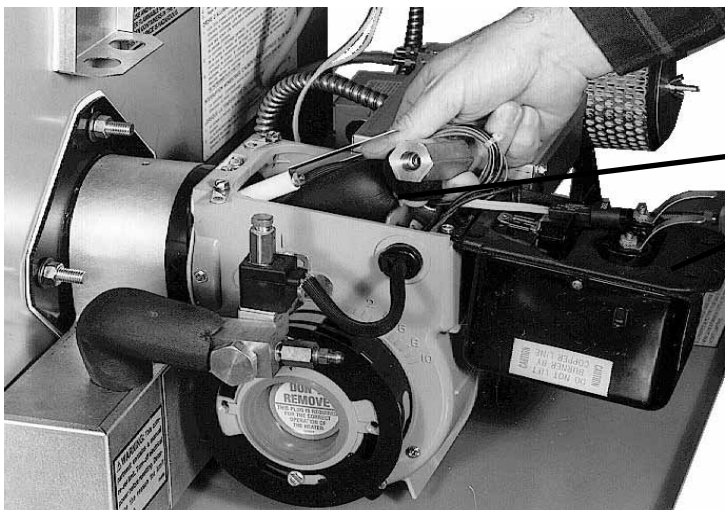

Fuel Connection

Transformer in the “open” position



Fuel Line Assembly Removed

Servicing/ Replacing Spark Electrodes

4. **There are eight wires in the fuel line assembly wire bundle.**
 - Mark and disconnect the wires from their terminals in the burner junction box.
5. **Disconnect the nozzle air hose from the fitting at the air compressor.**
 - Pull the hose through the opening “into” the burner housing.
6. **The fuel line assembly may now be removed by either**
 - Pulling the assembly up slightly and toward the rear of the burner housing.
 - OR removing the burner and end cone and pulling straight out of the blast tube. See page 29 for details.

To service or replace the Spark Electrodes

Remove any carbon formation on the spark electrodes.

- Check the electrodes for deterioration and the insulators for cracks or damage.
- Replace the electrode assemblies if any damage or deterioration exists, replace the electrodes, kit (P/N 269820).
- After service or replacement, check the position of the electrodes.
- Adjust the electrode location precisely.

Electrode Adjustment

Check the placement of the electrodes according to the illustration below. If adjustments are required, loosen the 1/4” screw. Make adjustments in the order listed below. Recheck, and if necessary, re-adjust until electrodes are in proper position.

- 1) **From center of nozzle orifice to electrode - up 3/8” (9.5mm)**
- 2) **Electrode Gap (distance between electrodes - 3/32” (2.4mm)**
- 3) **Relationship of the end of the electrodes to the tip of the nozzle - 1/16” (1.6mm) ahead**
- 4) **Relationship of the tip of the nozzle to the inside radius of the end cone -- Flush to 1/16” (1.6mm) ahead - NEVER BEHIND**

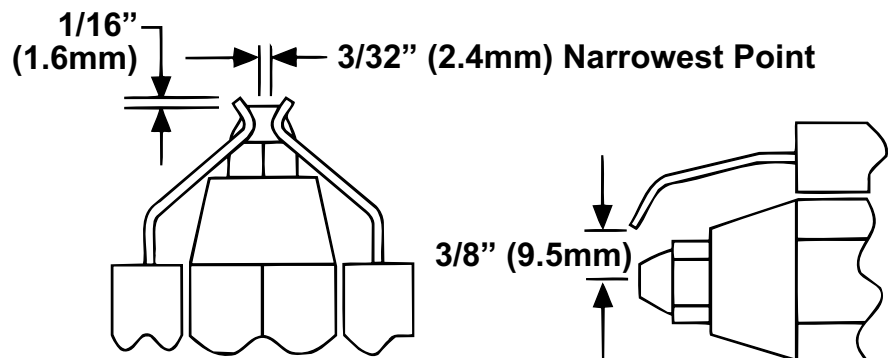

Maintenance Procedures Continued

Reassembling the Fuel Line Assembly

1. To reassemble the Fuel Line Assembly
 - Slide the fuel line assembly into the burner housing and the burner tube.
2. Connect the fuel connection assembly to the fuel line assembly.
 - Tighten the 5/16" inverted flare nut firmly. Then tighten the connection nut. Do not move the escutcheon plate.
 - Check the spacing between the oil nozzle and the end cone. Refer to "Electrode Adjustment" #4 (page 31).
3. Connect the eight wires in the fuel line assembly wiring bundle. Refer to the wiring diagram in the Appendix of this manual or the wiring diagram on the heater.
4. Push the air line hose out through the burner housing and reconnect it to the air compressor.
5. Close the spark transformer cover and attach with the two screws. Be certain transformer clips make contact with the electrodes.

NOTE: Once assembly is in place, verify that the nozzle, end cone, and electrodes are correctly located.

Cleaning Oil Pre-Heater System

WARNING

Turn off the electric power and allow the pre-heater to cool before servicing.

1. Remove the Pre-Heater from the Pre-Heater Box
 - Remove the corner panel from the end of the box. The pre-heater controls are visible.
 - Disconnect the fuel lines at the inlet and outlet connections. NOTE: There will be oil in the lines.
 - Disconnect wires to the temperature controls.
 - Disconnect the heating element wires.
 - Remove the screw that attaches the pre-heater front support to the bottom of the box.
 - Slide the cylindrical aluminium pre-heater out of the box.

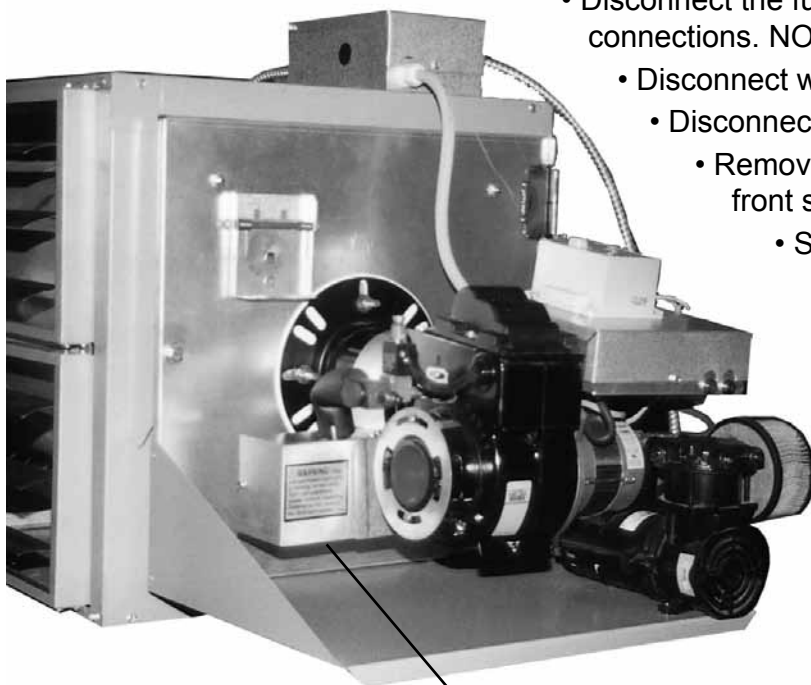

Pre-Heater Box



Pre-heater Controls

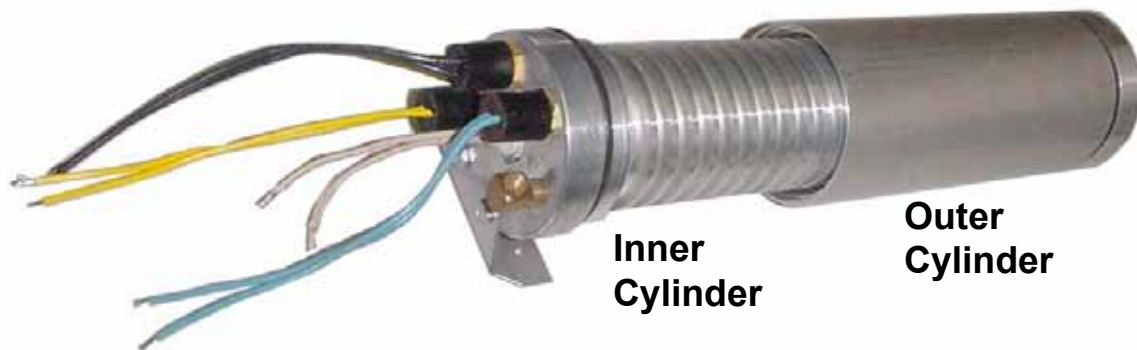

2. Clean the Pre-heater

- Place the pre-heater in a vice and carefully remove the outer cylinder and the “O” ring. NOTE: There will be oil in the pre-heater.
- Clean the inner section with a cloth and degreaser such as carburetor cleaner. Be careful not to “clean” the electrical controls. Do not immerse in cleaning fluid.
- Clean the outer portion of the cylinder with degreaser.

3. Reassemble the Pre-Heater and the heater.

- Check the “O” ring. If a new one is required, replace with P/N 132224.
- Reassemble the cylinder pieces with “O” ring in place.
- Slide the pre-heater in the box and attach the front support. Reconnect the wires and the fuel lines and close the corner cover.
- Replace the burner assembly and reconnect the ignition controller.

Cleaning Exterior Surfaces of Combustion Chamber/Heat Exchanger and the Blower

WARNING

Turn off the electric power before cleaning heater.

To gain access to the outer surface of the combustion chamber/heat exchanger, remove the discharge louvers. If the discharge is on one side of the heater only (either front or back), remove the top panel on the opposite side to access the outer surface of the other side of the combustion chamber/heat exchanger drum.

- 1) Use a stiff brush and a shop vacuum to clean the accumulated dust and dirt from the exterior surface of the combustion chamber/heat exchanger drum.
- 2) Clean the blower. Remove the guard on the open end of the blower. Use a brush and a shop vacuum, being careful not to bend or damage the blower wheel. Use a shop vacuum to remove accumulated dirt from the motor.
- 3) Replace the blower guard(s), discharge louvers, and any panels removed.
- 4) Connect the flexible conduit and wiring.
- 5) Check operation.

Cleaning ensures maximum efficiency and eliminates the possibility of the heater cycling on the limit switch from lack of air flow.

Service

General Service

Reznor® used oil heaters have been designed and manufactured to provide years of trouble free operation.

However, as with any type of mechanical equipment, it can malfunction. For your safety, we suggest that if you are unfamiliar with servicing this type of equipment, contact a qualified service person. The material contained in this section is prepared to aid an experienced service person in diagnosing and repairing a Reznor Model RV used oil heater.

General Operation

How a Reznor® Model RV Used Oil Heater Operates

When service is necessary, it is always helpful to understand the operation of the device being serviced. With this in mind, the following information has been prepared. Because of the many unique features of the heater, we as the designer and manufacturer believe that it will be worth your time to read this information before beginning any service function.

The Model RV heater differs from most residential and commercial oil furnaces and used oil heaters in that the oil pump meters the volume of oil supplied to the burner. A constant volume of oil is delivered by the pump to the burner regardless of the oil viscosity. Oil pressure at the outlet of the pump will vary depending upon oil grade, the length and height of the supply line, and the oil temperature.

If a pressure in excess of 50 psi is experienced at the pump, a relief valve will open and return the oil to the supply tank.

Oil pressure at the atomizing nozzle will vary from .25 psi to 4 psi depending on the type of oil being burned. Nozzle oil pressure is not critical because compressed air is used to atomize the oil.

The solenoid valve located adjacent to the burner housing performs two tasks. The primary task is to prevent oil from flowing into the combustion chamber due to oil expansion in the heater. The second task is to assist in preventing oil from flowing backwards. Both the solenoid valve and the pump motor are turned on and off by the ignition controller. The check valve at the pump prevents backwards flow of oil in both the heater supply line and the suction line to the pump.

To properly atomize the different types of used oil, the oil must be heated. The oil flows through an aluminum heat exchanger (pre-heater) with a 300 watt heating element. This oil heater which is external to the burner preheats the oil to approximately 175°F. A pair of 30 watt heating elements on the fuel line and nozzle assembly within the burner maintain an oil atomizing temperature of 160°F. Temperature sensors prevent burner operation until the proper temperatures are attained. Oil temperature is maintained continuously as long as the electrical power is on to the heater.

General Operation Continued

Compressed air for atomizing the used oil is supplied by a piston-type compressor mounted on the service tray. Model RV heaters require air pressure within a 9 to 12 psi range for proper oil atomization. To assure that the correct atomizing air pressure is available, a pressure switch permits oil flow to the nozzle only when a minimum of 9 psi is sensed.

Combustion air is supplied by a blower contained in the burner housing. An adjustable air shutter and air band located on the outside of the burner housing control the quantity of combustion air. Both are preset at the factory and should be changed only if the CO₂ measurement indicates the need to do so. See Check-Test-Start, for instructions for measuring CO₂.

Ignition of the atomized oil and combustion air mixture is accomplished by a high voltage spark across the two electrodes located near the atomizing nozzle. Ignition of the oil is detected by a cadmium sulfide flame sensor. Light produced by the flame lowers the electrical resistance of the cad cell. This change is sensed by the ignition controller which allows a continued flow of oil and shuts off the spark transformer after a 10-second trial-for-ignition period.

If for some reason, ignition does not occur or the flame goes out during the trial period, the primary control will lockout. To restart, the safety switch must be manually reset by pushing the red reset button on the ignition (primary) controller. Push and hold the reset button for three seconds. If the heater does not ignite, contact your service person.

If the instructions in this manual are followed, excessive amounts of unburned oil will not accumulate inside the combustion chamber. If the caution statement about resetting the controller more than one time is not heeded, then unburned oil will accumulate in the combustion chamber. **If unburned oil accumulates, DO NOT** attempt to fire the heater and burn off the oil. Allow the unit to cool. Turn off the power, open the burner door, and wipe out any accumulated oil with cloth rags. Properly dispose of the rags.

If the flame fails during normal operation, the heater will go into the recycle mode. The burner will shutdown and enter a 60-second recycle delay. The ignition sequence is then started. If the flame is not re-established, the ignition controller will go into lockout requiring manual reset of the controller. If the heater does not ignite after resetting the controller, contact your service person.

If power fails, the heater will shut down and normal trial for ignition will begin on call for heat when the power is restored.

Approximately 1-1/2 to 2 minutes after the thermostat calls for heat and ignition is established, the circulating blower will come on. The circulating airflow will continue about three minutes after the burner shuts down.

WARNING

Do not reset the primary control more than one time. If the heater does not ignite, contact your service person.

Troubleshooting

Oil Burner Troubleshooting

To diagnose malfunctions properly, the following test equipment is required:

- 1) An electrical test meter that can measure AC volts, ohms, and amps;
- 2) A combustion analyzer kit to measure oxygen and/or carbon dioxide, smoke, stack temperature, and draft; and
- 3) Two pressure gauges with scales of 0-100 PSIG and 0-30 PSIG.

Before test firing any heater, check the combustion chamber for an excessive accumulation of unburned oil and restore to safe condition before firing. (See page 35.)

WARNING

Do not attempt to start the burner when excess oil has accumulated, when the heater is full of vapor, or when the combustion chamber is very hot.

NOTE: Refer to the troubleshooting guide on page 37 to select the appropriate troubleshooting chart.

Indicator Lights

Check the Indicator Lights

Color	Location	Function
GREEN	On the electrical box on the top of the heater	Indicates that the main power is on to the heater
GREEN	On the electrical box on the burner assembly	Indicates that all limits have been satisfied and the unit is ready to operate

Backflow Sensor

Backflow Sensor Switch

Description/Application - The backflow sensor is a manually reset temperature-sensitive switch that is designed to shutdown the heater when there is a positive pressure in the combustion chamber. The heater is designed to operate with an overfire draft of -0.01" to -0.02" w.c. Prolonged operation at a positive pressure (≥ 0.00 " w.c.) can cause overheating and accidental component failure. Undesirable positive heater pressure can be caused by any one or a combination of the following conditions:

- Totally or partially blocked flue gas venting system
- Improperly designed venting system
- Improper fuel-to-air ratio for combustion
- Excessive ash buildup in the heat exchanger
- Improper atomization of the fuel
- Plugged or defective fuel nozzle
- Improperly adjusted fuel nozzle assembly
- Burning off-specification fuel
- Changes in outside ambient temperature

Backflow sensor is on the burner door. Manually reset the backflow sensor switch.

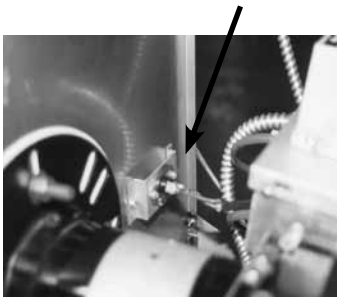

Location - The backflow sensor switch is mounted on the burner door.

Operation - Underneath the sensor bracket, there is a 1/4" diameter hole. Under normal negative overfire operating conditions, room air is constantly drawn into that small opening. The temperature-sensitive backflow sensor is "cooled" by the air flow. If for any of the reasons listed, the heater pressure becomes zero, or slightly positive, the flow of air decreases. If this condition persists (10 minutes maximum) the "uncooled" backflow sensor activates interrupting power to the ignition controller. The green limit status light on the burner electrical box will go out; the heater goes through the normal post purge and cool down cycle.

After the problem has been determined and corrected, push the manual reset button on the backflow sensor, and follow the instructions to relight the heater. Check for proper operation.

Maintenance - A thin film of soot will form on the face of the backflow sensor. At least once a month and during any routine heater cleaning, clean the soot from the sensor. Check the wire connections during scheduled maintenance inspections.

Troubleshooting Chart Guide

Symptom	Follow Troubleshooting Chart
With thermostat calling for heat, burner motor never attempts to run (Green "power on" light is lit; Green "system ready" light is not lit). ...	Chart No. 1, page 39
Chart 1 check completed, but burner motor never attempts to run. With thermostat calling for heat, burner motor runs momentarily.	Chart No. 2, page 41
System does not attempt to ignite.	Chart No. 3, page 42
Burner ignites and burns steadily until system goes into lockout.	Chart No. 4, page 43
Burner operation erratic/unstable flame pattern.	Chart No. 5, page 44
High temperature limit cycles.	Chart No, 6, page 45
Oil delivery system troubleshooting.	Chart No. 7, page 47

CAUTION: The items on the Troubleshooting Charts that are marked with an asterisk represent events that have occurred due to the improper functioning of the heater. It is necessary to observe the operation of the heater to determine what caused these events to occur.

Troubleshooting Location of Components Referenced in Troubleshooting Charts

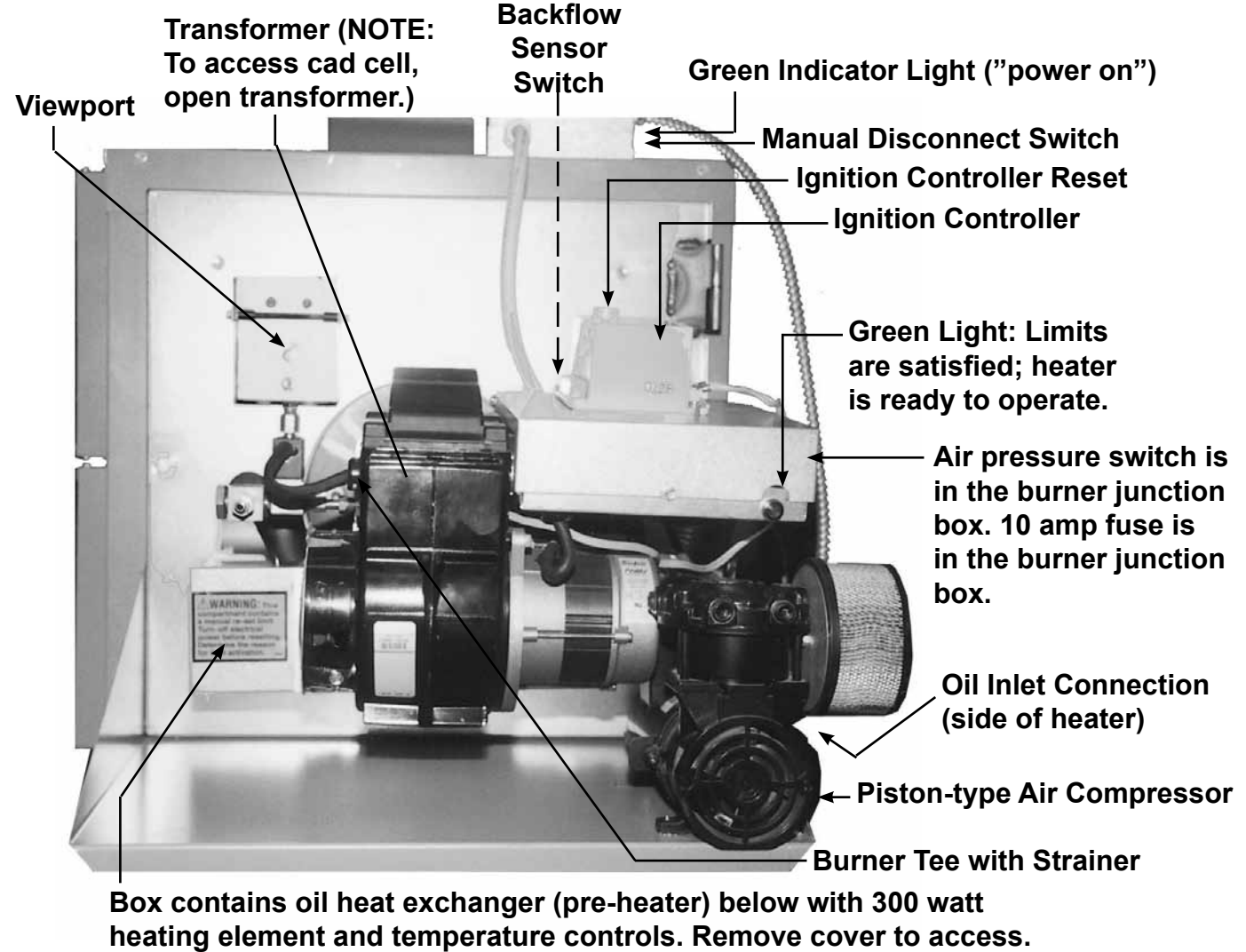

Oil Pre-Heat Exchanger Reference Chart No. 1 (next page)

Locations and Replacement Instructions for Heating Element and Temperature Controls on Oil Pre-heat Heat Exchanger

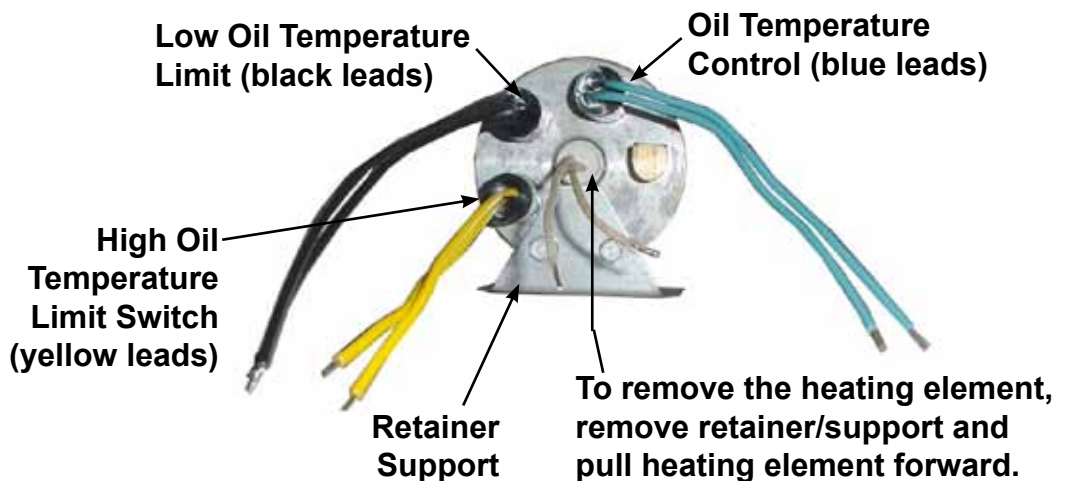

Troubleshooting Continued

Chart No. 1 - Thermostat calling for heat; Burner motor never attempts to run.

FIRST, follow the instructions in the box below. Refer to the illustrations on the previous page and on the next page.

Turn on the main power to the unit at the disconnect switch and wait at least 15 minutes before proceeding.

- If GREEN "system ready" light is NOT LIT, continue with the troubleshooting guide in CHART No. 1 (left).
- If the GREEN "system ready" light is LIT, skip to Chart No. 2 (next page).

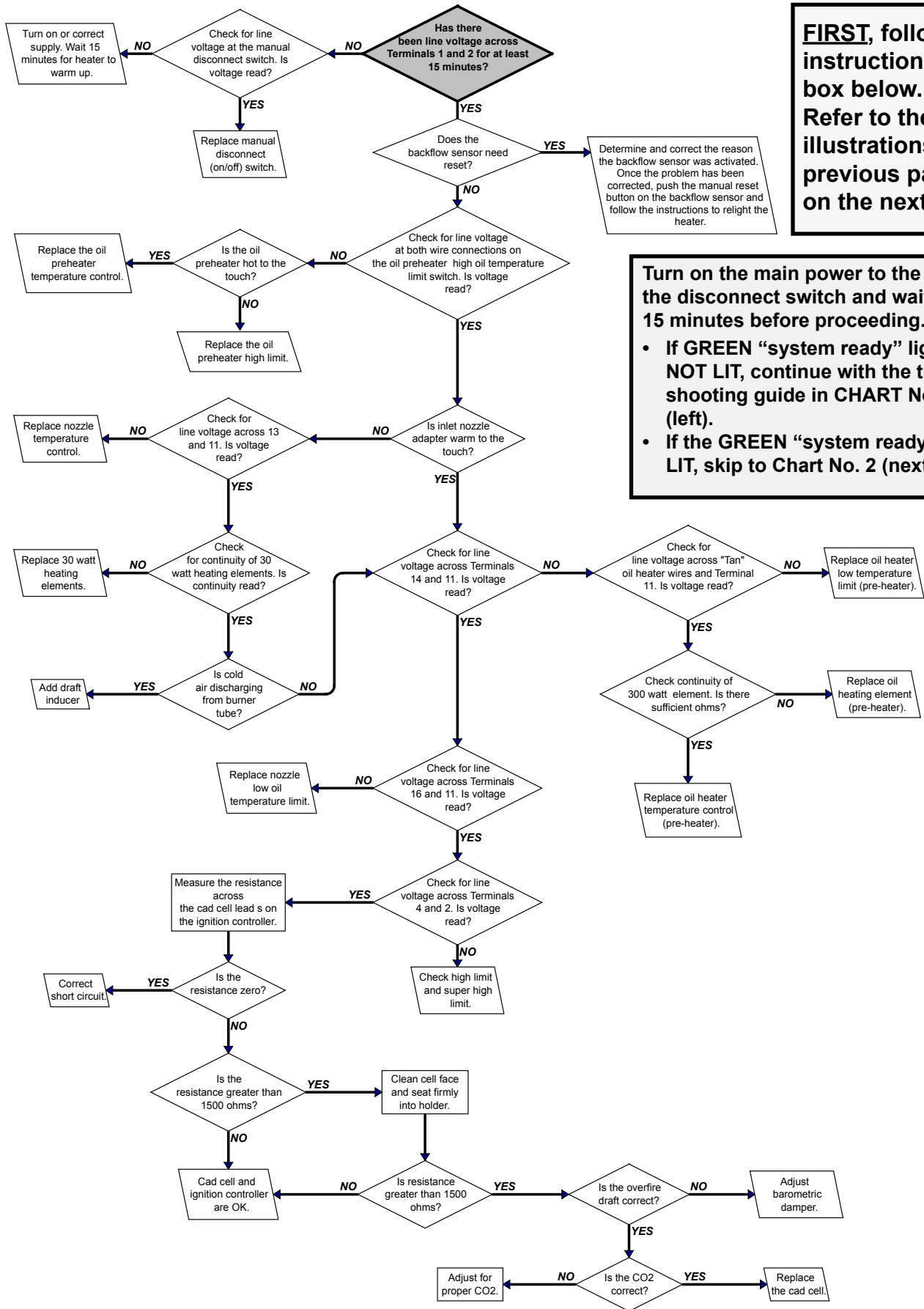

Troubleshooting Continued

Fuel Line Assembly Reference Chart No. 1

Locations and Replacement Instructions for the Two 30 Watt Heating Elements in the Fuel Line Assembly

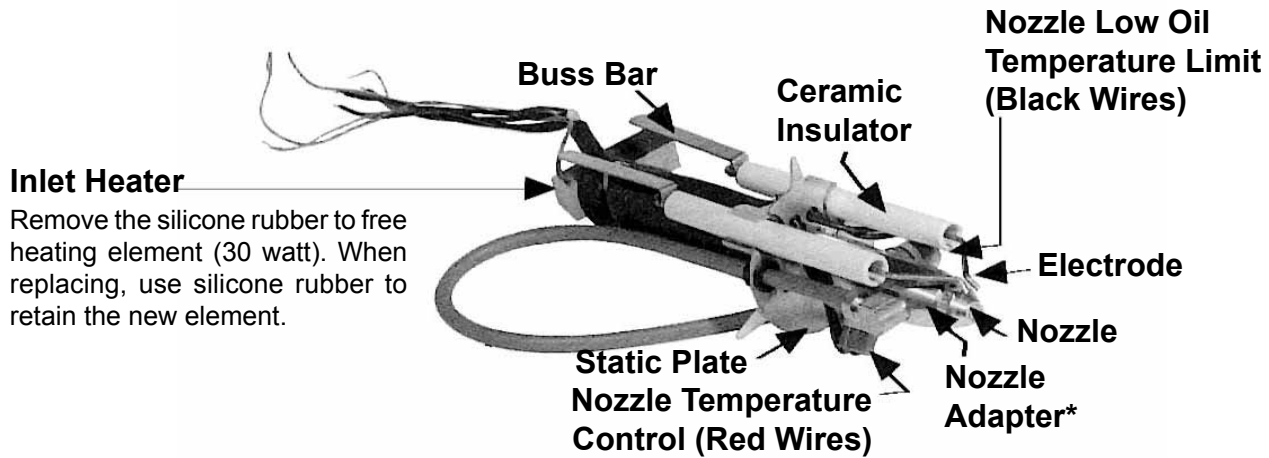

- *The nozzle adapter contains a 30 watt heating element. To replace the element:
- 1) Remove the buss bars.
 - 2) Unscrew the inlet heater and slide the black insulation rearward. Loosen set screw which retains the static plate and slide rearward. This will expose the heating element.

Troubleshooting Chart No. 2 - Thermostat calling for heat, burner motor never attempts to run (green light is lit) indicating "System Ready". Chart No. 1 has been successfully completed.

NOTE: After ignition control is reset, you will have 30 SECONDS to perform the tests shown below before the controller locks out.

Reset ignition control: Press the RED BUTTON, hold for four seconds, and release. DO NOT RESET MORE THAN ONE TIME.

Refer to illustration on page 38.

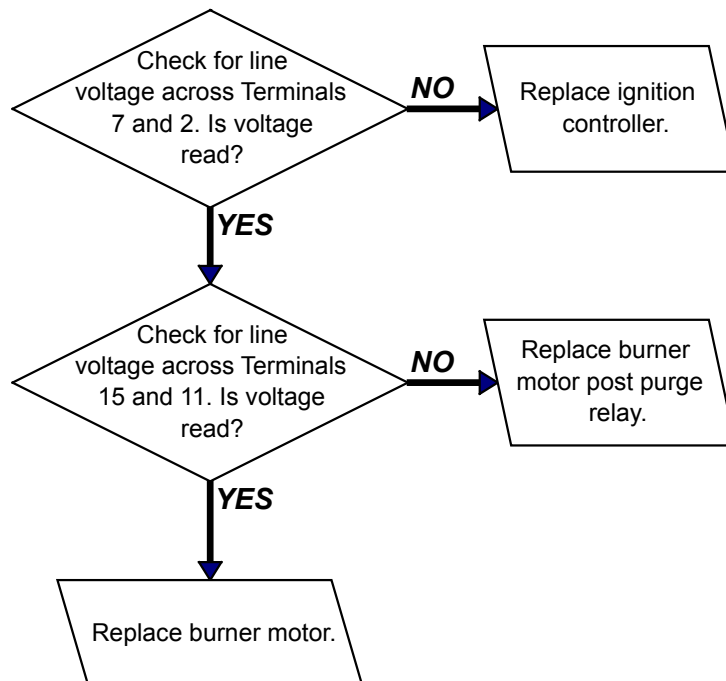

Troubleshooting Chart No. 3 - Thermostat is calling for heat. Burner motor runs for about 30-45 seconds. System does not attempt to ignite.

First, check combustion chamber for excess oil.

NOTE: After ignition control is reset, you will have 15 SECONDS to perform the tests shown below before the controller locks out.

Reset ignition control: Press the RED BUTTON and release. DO NOT RESET MORE THAN ONE TIME.

Transformer and Electrode Checks:

Measure voltage between transformer/primary lead and neutral connection. Check transformer, insulators, and electrodes.

The secondary terminals of a good transformer deliver 7,000 volts arc to ground, for a total of 14,000 volts between terminals. Measure this with a transformer tester or use a well insulated screwdriver to draw an arc across the two springs. This should be at least 3/4" in length. Check each secondary output terminal by drawing a strong arc between the spring and base. If the arc is erratic, weak, or unbalanced between the two terminals, replace the transformer. Replace electrodes when the tips become worn or eroded.

Replace any insulators that are questionable. Transformer failures and ignition problem can be caused by the following:

- Excessive gap on the ignition electrodes. Gap should be 3/32".
- High ambient temperatures
- High humidity
- Carbon residue on the porcelain bushings
- Low input line voltage
- Arcing between the ignition electrodes and the transformer springs. They must have good contact.
- Carbon residue, moisture, crazing or pin holes on the insulators
- Improper positioning of nozzle in relation to the radius of the end cone
- Carbon residue on electrode parts

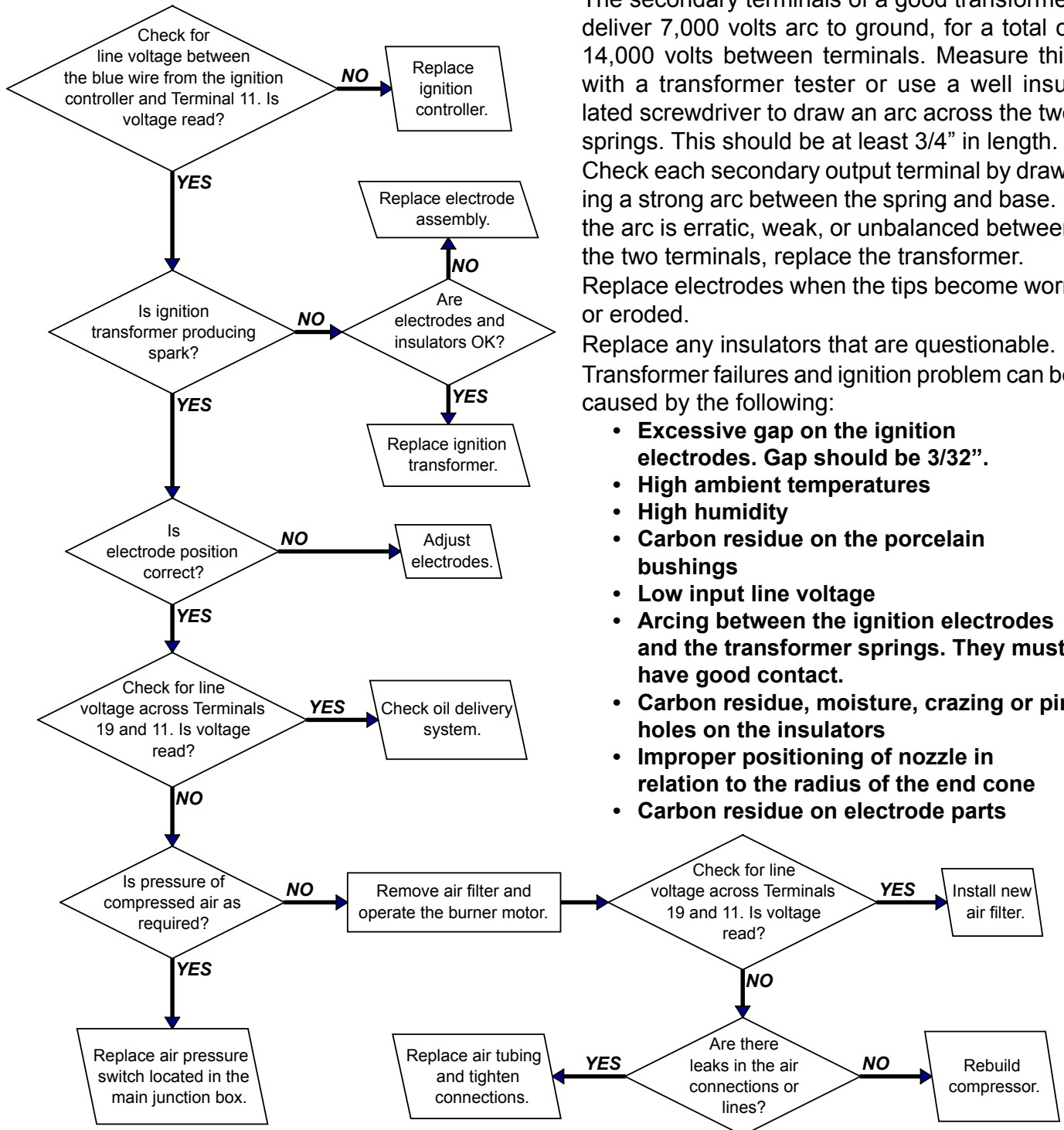

Troubleshooting Continued

Chart No. 4 - Burner ignites and burns steadily until the system goes into lockout.

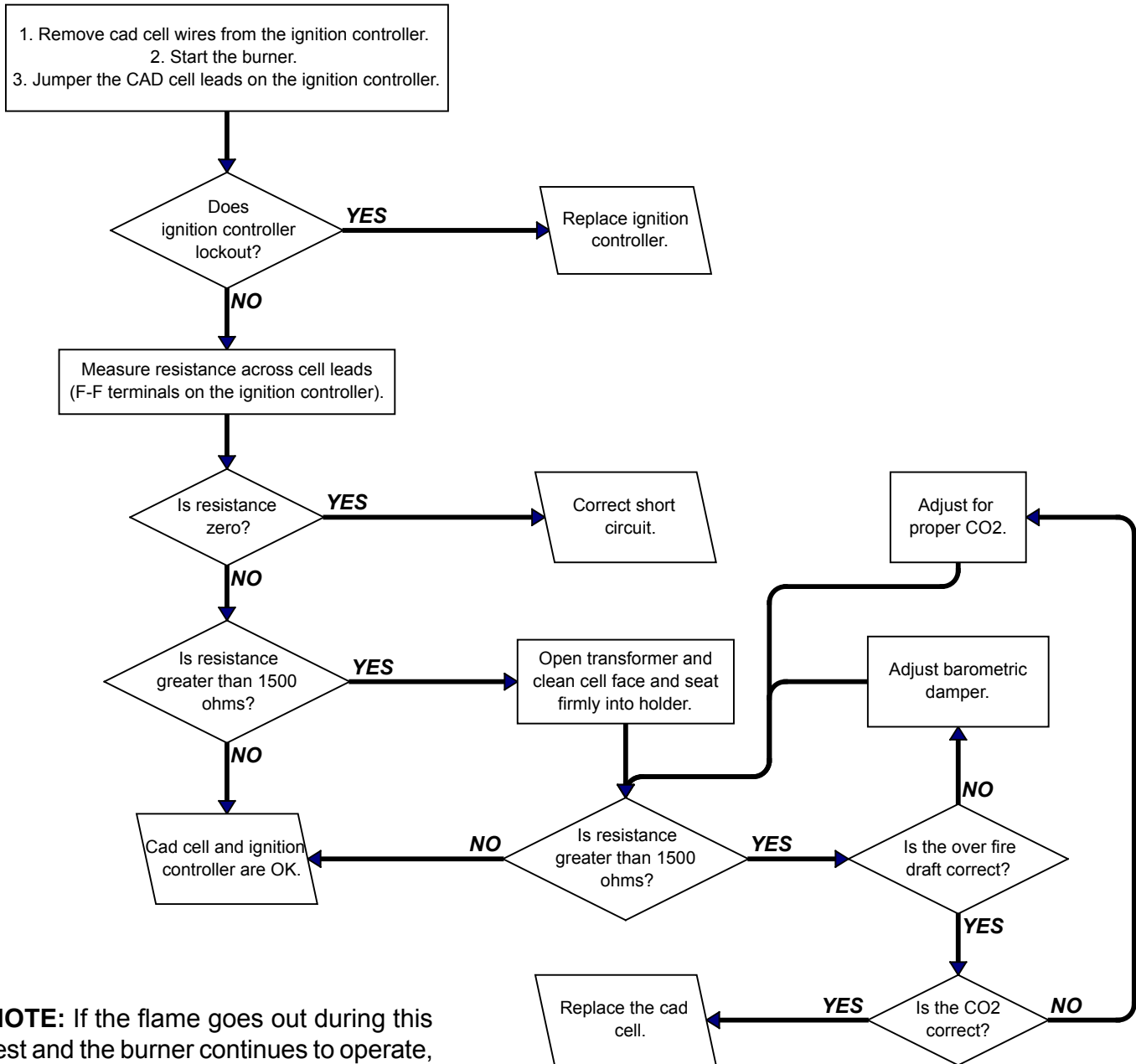

NOTE: If the flame goes out during this test and the burner continues to operate, go to Chart No. 5.

Chart No. 5 - Thermostat calling for heat. Burner operation erratic/unstable flame pattern.

Refer to illustration on page 38.

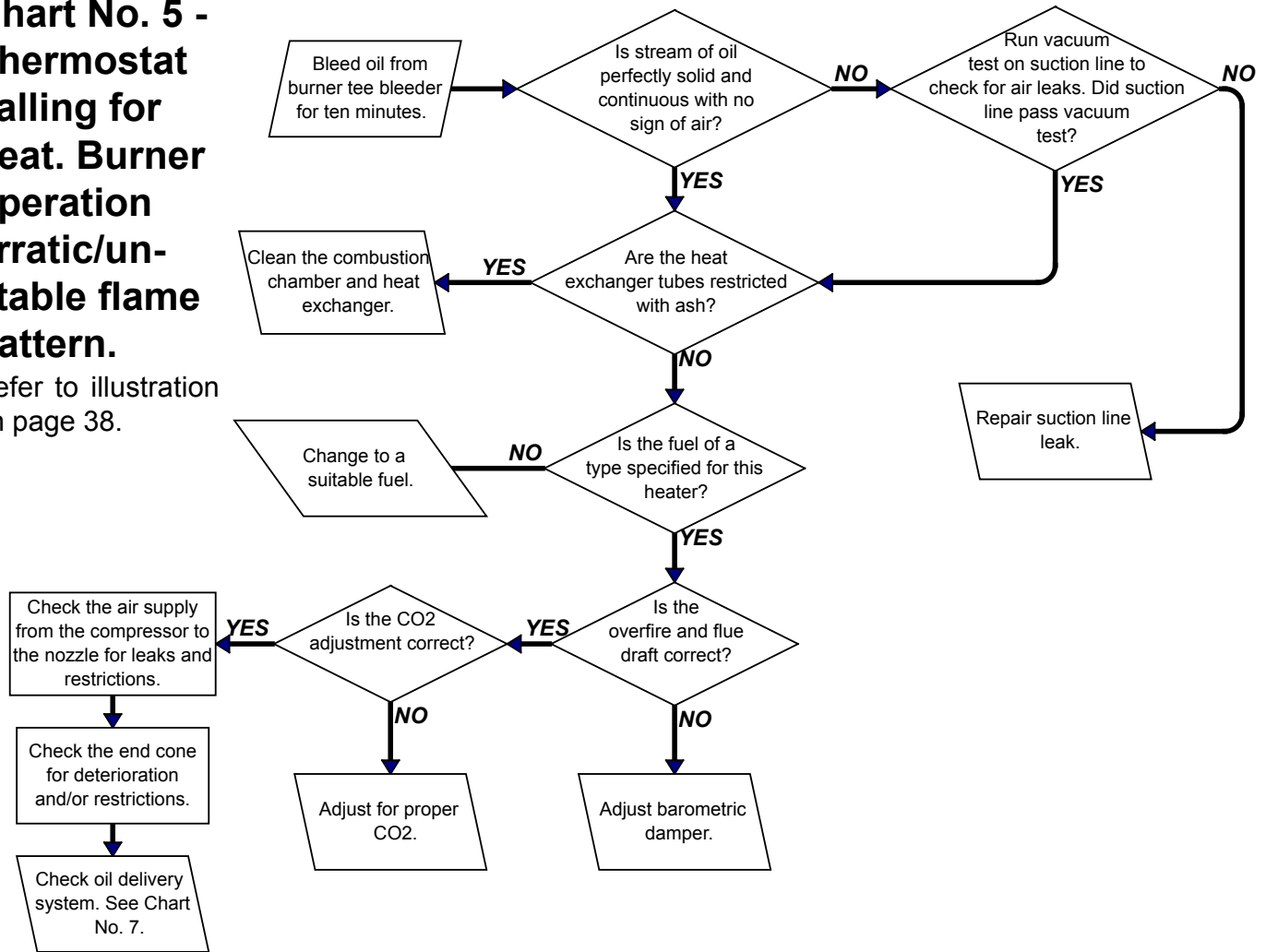
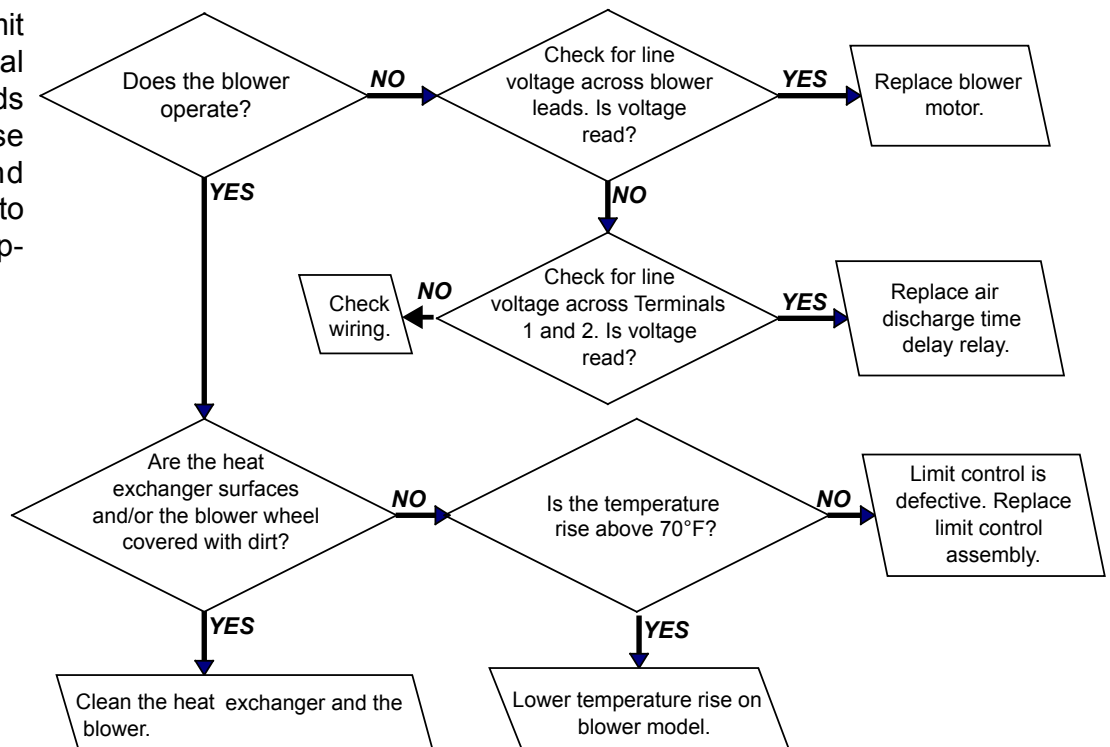

Chart No. 6 - High Temperature Limit Cycles

High temperature limit cycles when internal temperature exceeds limit setpoint. Cause must be found and corrected for heater to function safely/properly.

Refer to illustration on page 44.



Troubleshooting Continued

Blower and Limit Controls

Model RV heaters are equipped with a blower control (time delay relay), a circulating air high limit control, and a super high limit control.

Function

The main functions of the **blower control** are to provide:

- Delay of blower operation, preventing circulation of cold air at startup.
- Continued blower operation as long as the unit temperature is above minimum setting. The blower control also provides additional safety control by keeping the blower in operation in the event that a malfunction would cause the oil burner to continue to fire when the thermostat is satisfied.

The **circulating air high limit switch** is nonadjustable and automatically cycles when the internal temperature exceeds the setpoint. For the heater to operate properly and safely, the cause for the temperature exceeding the high limit setpoint must be corrected. Setpoints for Model RV225 are Open 155°F/Close 135°F; setpoints for Model RV325 are Open 170°F/Close 130°F.

The **super high limit switch** provides redundant control and is calibrated to open at a much higher temperature (350°F) than the standard automatic reset limit switch indicates a major failure caused by a malfunction of the primary safety controls or miswiring. Before attempting to re-start the heater the cause must be corrected and the blower and limit control assembly replaced.

Location

These controls are accessed from the top of the heater; see illustrations below.

On the top of the heater, loosen the warning plate to access limit controls.

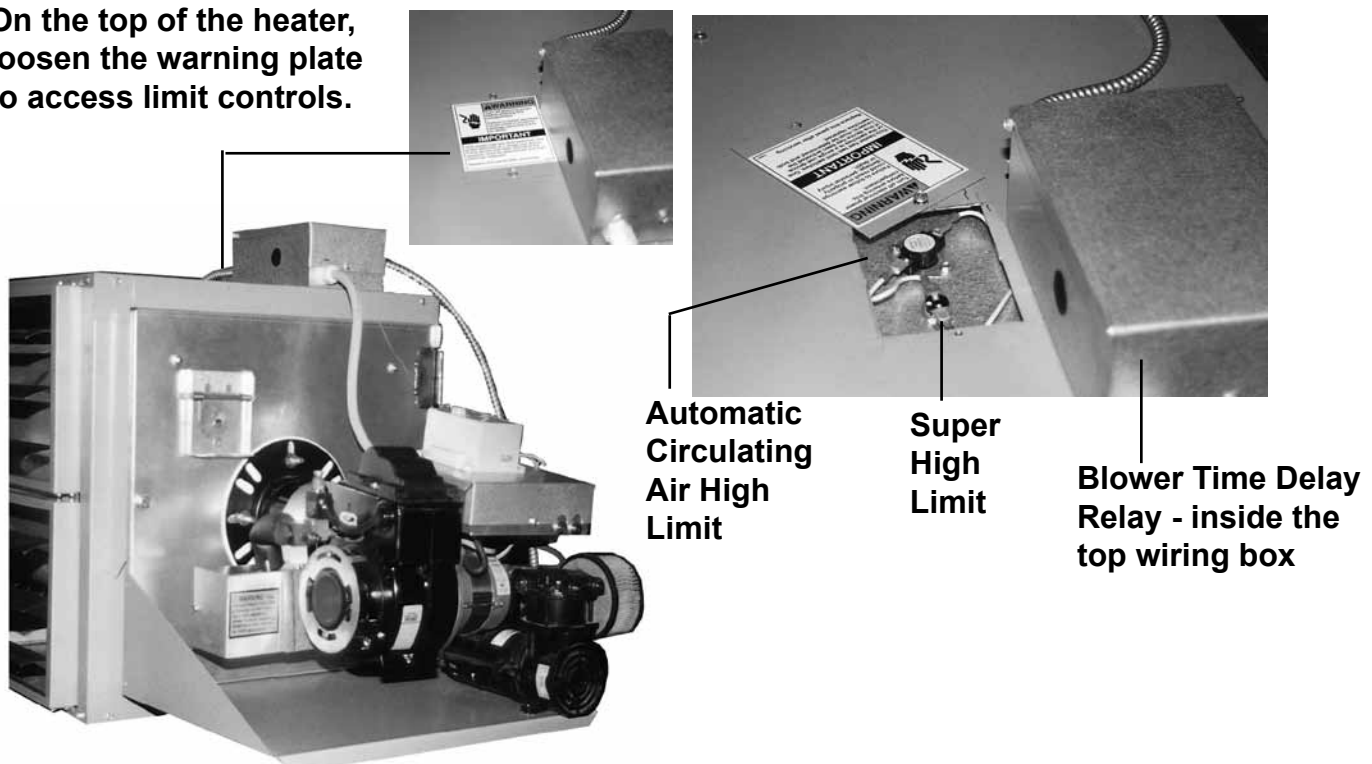

Troubleshooting Continued

Chart No. 7 - Oil Delivery System

CAUTION: If the heater will be shut down for a long period, turn off the electric power.

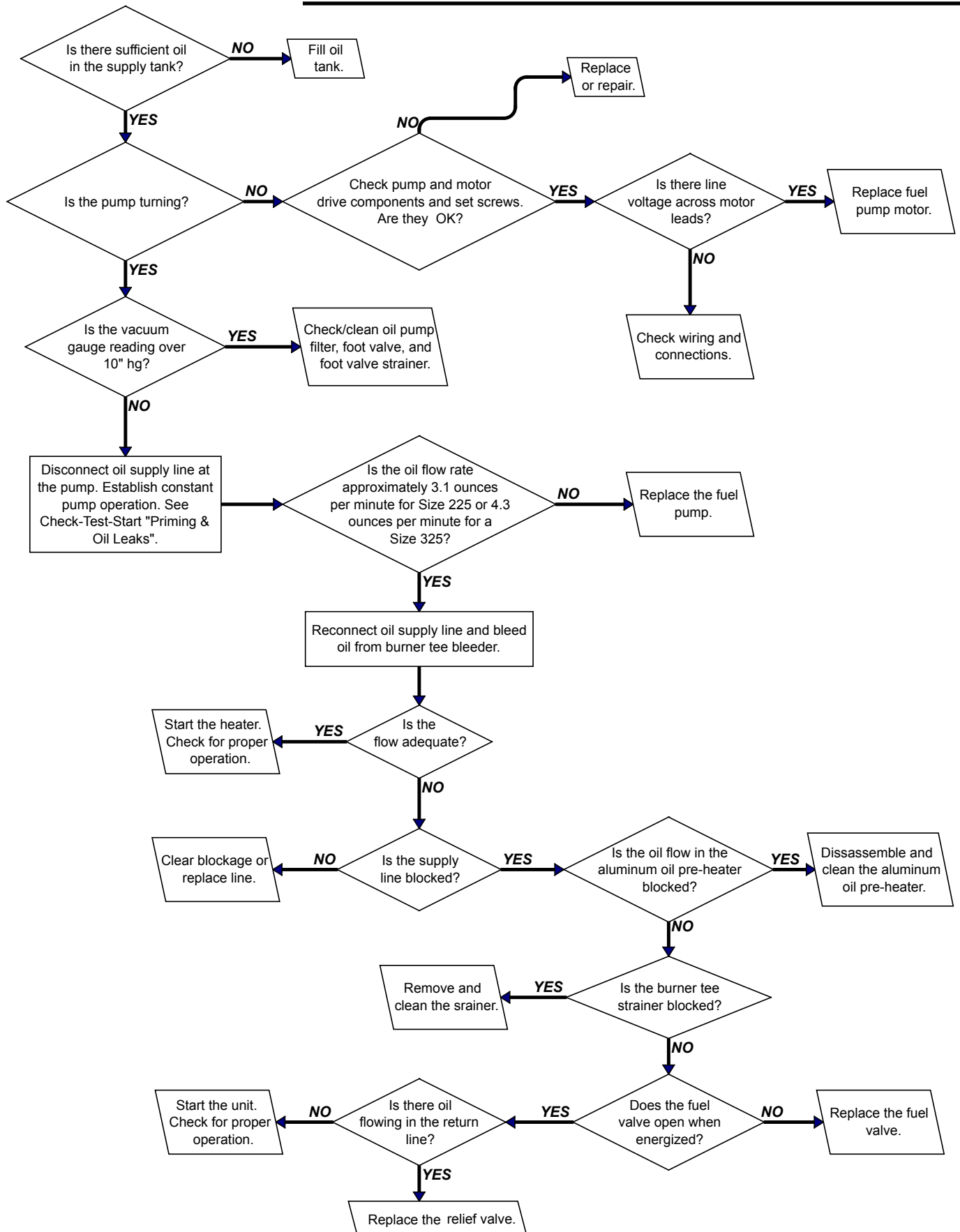

Appendix

Wiring Diagram 186251 for Model RV225

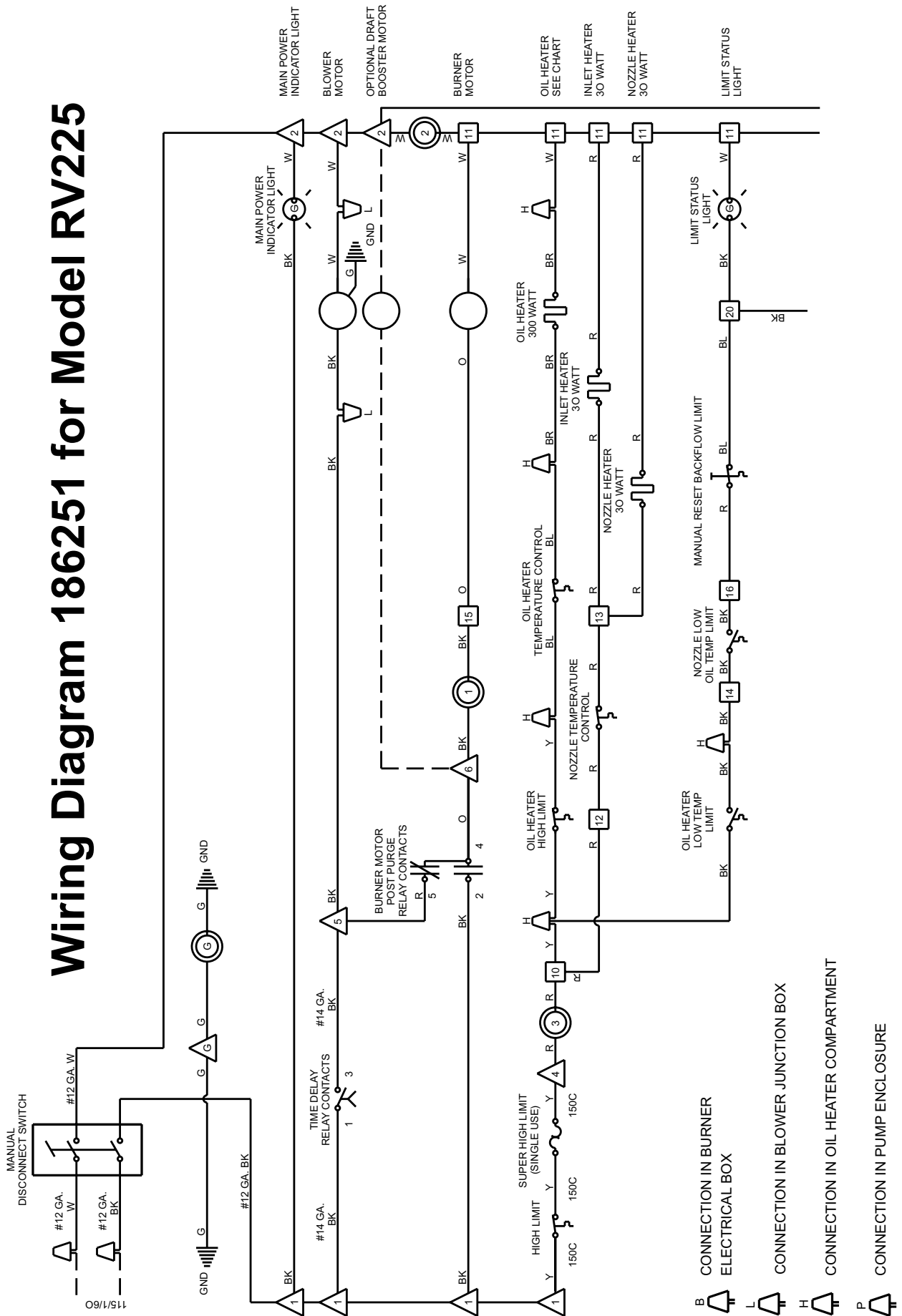

WIRING CODE
 BLACK - BK
 BROWN - BR
 RED - R
 ORANGE - O
 YELLOW - Y
 GREEN - G
 BLUE - BL
 PURPLE - PR
 WHITE - W

FACTORY WIRING

FIELD WIRING

● CRIMP CONNECTION

○ BURNER DISCONNECT

□ TERMINAL BLOCK - BURNER JUNCTION BOX

△ TERMINAL BLOCK - TOP WIRING BOX

△ UNIT TERMINALS

G 10
 1 11
 2 12
 4 13
 5 14
 6 15
 7 16
 17
 18
 19
 20

CONTROL TEMPERATURE LIMITS		
CONTROL	STYLE	ACTIVATE RESET
MANUAL RESET HIGH LIMIT	NC	45°F
OIL HEATER TEMP CONTROL	NC	220°F
NOZZLE TEMP CONTROL	NC	170°F
OIL HEATER LOW TEMP LIMIT	NO	155°F
NOZZLE LOW OIL TEMP LIMIT	NO	160°F
HIGH LIMIT	NC	155°F
SUPER HIGH LIMIT	NC	140°F
MANUAL RESET VIEWPORT LIMIT	NC	145°F
	NC	105°F
	NC	90°F
	NC	350°F
	NC	275°F
		MANUAL

REFER TO : WIRING DIAGRAM LABEL 203221
 (TOP WIRING BOX)

WIRING DIAGRAM LABEL 203223 (BURNER
 JUNCTION BOX)

FIELD CONNECTION CHART			
SOURCE	TO LOCATION	COLOR	CONNECTION TYPE GAUGE
115 V POWER SUPPLY	TOP JUNCTION BOX	BLACK	WIRE NUT-BLACK WIRE 12 MIN
115 V POWER SUPPLY	TOP JUNCTION BOX	WHITE	WIRE NUT-WHITE WIRE 12 MIN
115 V POWER SUPPLY	TOP JUNCTION BOX	BARE/GRN	WIRE NUT-GREEN WIRE 12 MIN
REMOTE PUMP	TOP JUNCTION BOX	WHITE	TERMINAL BLOCK 7 14 MIN
REMOTE PUMP	TOP JUNCTION BOX	BARE/GRN	GROUND TERMINAL 14 MIN
THERMOSTAT	IGNITION CONTROL	WHITE	TERMINAL T1 SCREW 18 MIN
OPT DRAFT BOOSTER	IGNITION CONTROL	RED	TERMINAL T2 SCREW 18 MIN
OPT DRAFT BOOSTER	TOP JUNCTION BOX	WHITE	TERMINAL BLOCK 2 14 MIN
EXHAUST FLOW SWITCH	BURNER JUNCTION BOX	BARE/GRN	GROUND TERMINAL 14 MIN
EXHAUST FLOW SWITCH	BURNER JUNCTION BOX	ORANGE	TERMINAL BLOCK 17 18 MIN
			TERMINAL BLOCK 18 18 MIN

SHORTENED SEQUENCE OF OPERATION

SEE INSTALLATION & OPERATION INSTRUCTIONS FOR FULL DETAILS

1. WITH POWER SUPPLIED AND DISCONNECT SWITCH "ON", OIL HEATERS PREHEAT OIL. ON CALL FOR HEAT, THERMOSTAT CLOSURES CAUSING IGNITION CONTROLLER TO ENERGIZE BURNER. AIR MOVING DEVICES (FAN, AIR COMPRESSOR, REMOTE OIL PUMP AND IGNITION TRANSFORMER).
2. OIL IS IGNITED AND FLAME ESTABLISHED.
3. 30 - 45 SECONDS AFTER FLAME IS ESTABLISHED, THE FAN CONTROL ACTIVATES AIR MOVING DEVICES.
4. AIR MOVING DEVICES (FAN, AIR COMPRESSOR, REMOTE OIL PUMP, DE-ENERGIZING BURNER MOTOR, ATOMIZING AIR COMPRESSOR AND REMOTE OIL PUMP).
5. AIR MOVING DEVICES(S) CONTINUE TO OPERATE UNTIL THE HEAT EXCHANGER IS COOL (NOMINAL 3 MINUTES).
6. IF IGNITION DOES NOT OCCUR WITHIN 15 SECONDS THE IGNITION CONTROLLER WILL LOCK DOWN ON THE RED RESET BUTTON FOR (1) SECONDS AND THEN RELEASING IT. DO NOT RESET MORE THAN ONE TIME!

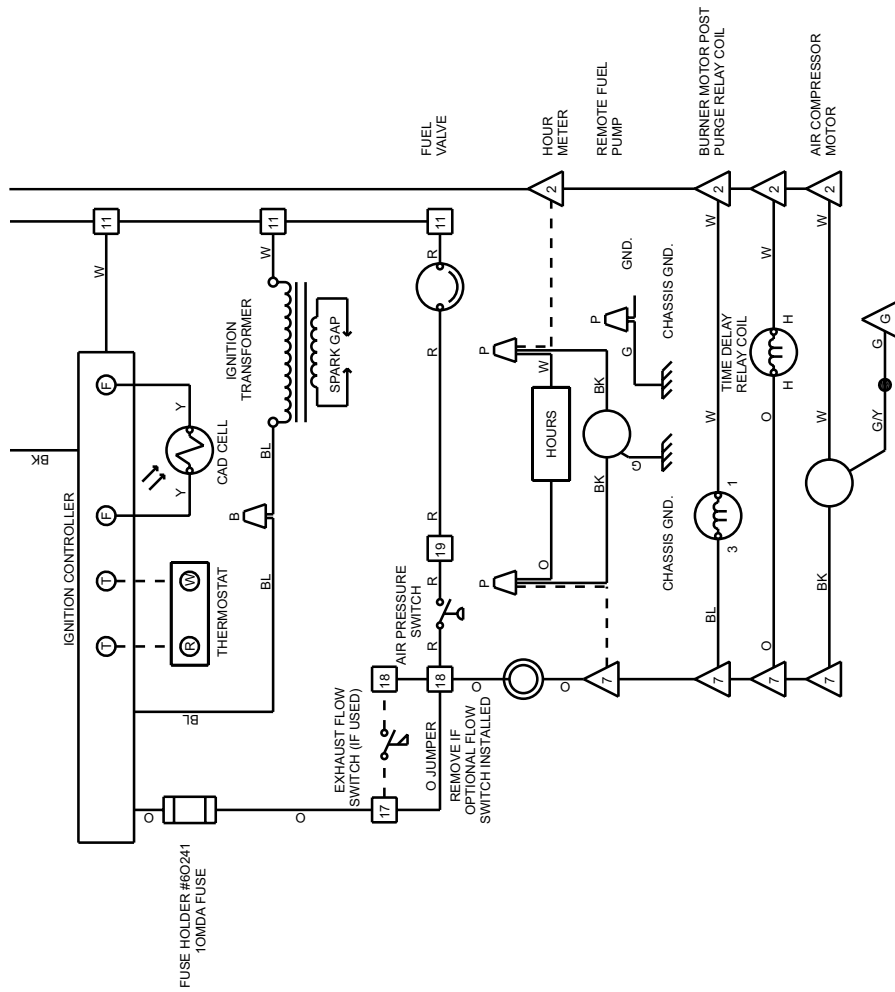

CAUTION: IF ANY OF THE ORIGINAL WIRE AS SUPPLIED WITH THE APPLIANCE MUST BE REPLACED, IT MUST BE REPLACED WITH WIRING MATERIAL HAVING A TEMPERATURE RATING OF AT LEAST 105°C. EXCEPT FOR HEATING ELEMENT AND LIMIT WIRING WHICH MUST BE 150°C.

RV 225 DWG. #B-186251 REV. #6

186251
 REV. #6

Wiring Diagram 186385 for Model RV325

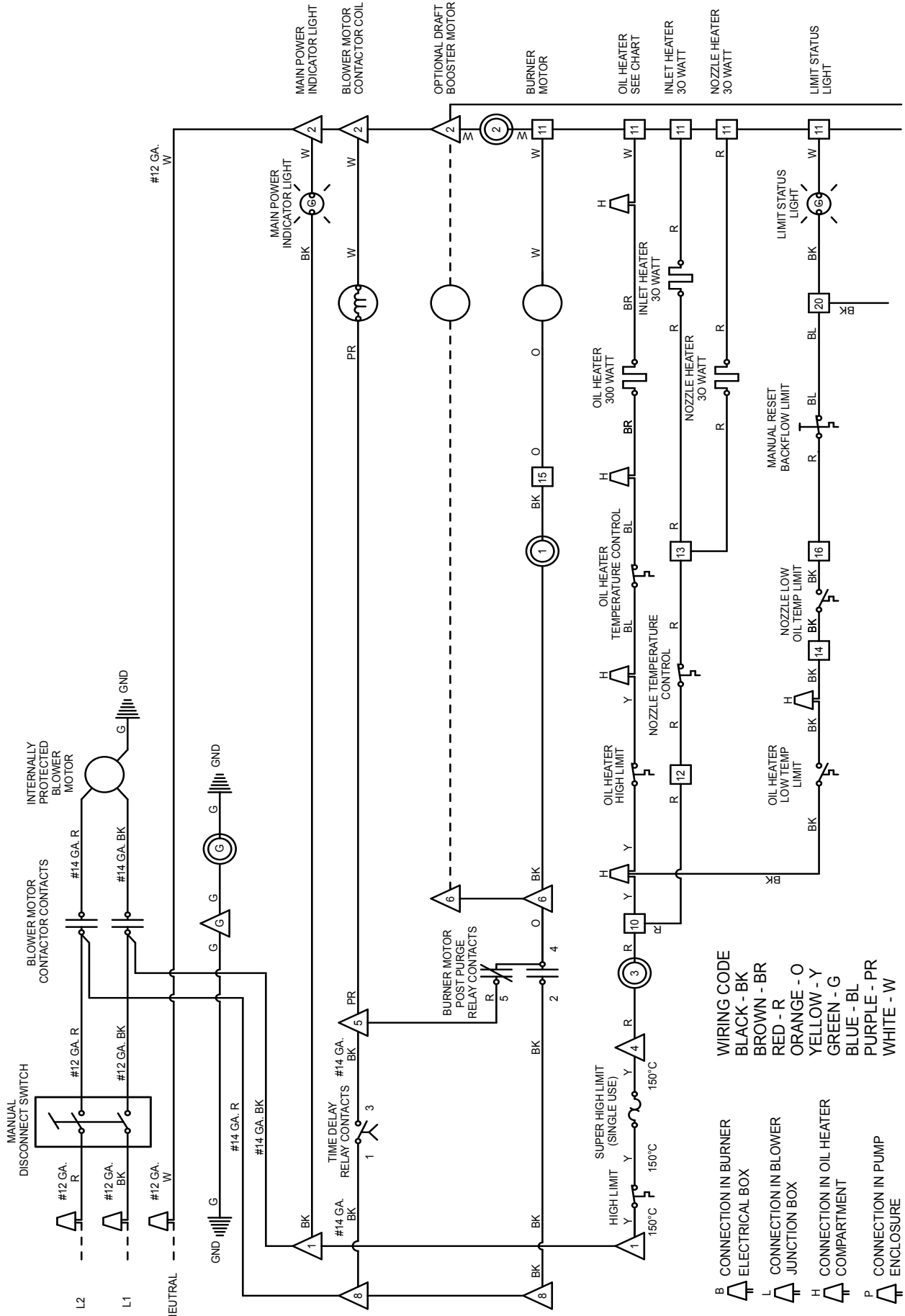

- WIRING CODE**
- B CONNECTION IN BURNER ELECTRICAL BOX
 - L CONNECTION IN BLOWER JUNCTION BOX
 - H CONNECTION IN OIL HEATER COMPARTMENT
 - P CONNECTION IN PUMP ENCLOSURE
- WIRING CODE**
- BLACK - BK
 - BROWN - BR
 - RED - R
 - ORANGE - O
 - YELLOW - Y
 - GREEN - G
 - BLUE - BL
 - PURPLE - PR
 - WHITE - W

230/1/60

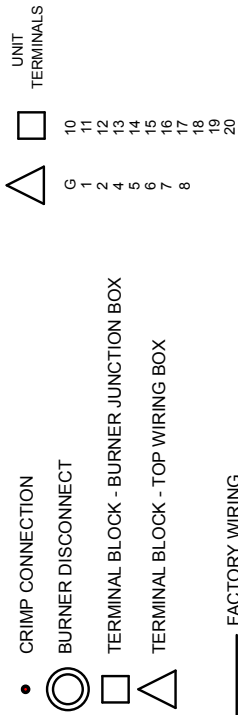

FACTORY WIRING
FIELD WIRING

CONTROL	STYLE	ACTIVATE	RESET
MANUAL RESET HIGH LIMIT	NC	220° F	45° F
OIL HEATER TEMP CONTROL	NC	170° F	155° F
NOZZLE TEMP CONTROL	NO	160° F	150° F
OIL HEATER LOW TEMP LIMIT	NO	155° F	140° F
NOZZLE LOW OIL TEMP LIMIT	NO	145° F	105° F
HIGH LIMIT	NC	150° F	90° F
SUPER HIGH LIMIT	NC	360° F	N/A
MANUAL RESET VIEWPORT LIMIT	NC	275° F	MANUAL

REFER TO : WIRING DIAGRAM LABEL #203222 (TOP WIRING BOX)

WIRING DIAGRAM LABEL #203223 (BURNER JUNCTION BOX)

SOURCE	TO LOCATION	COLOR	CONNECTION TYPE	GAUGE
230 V POWER SUPPLY	TOP JUNCTION BOX	BLACK	WIRE NUT--BLACK WIRE	12 MIN
230 V POWER SUPPLY	TOP JUNCTION BOX	RED	WIRE NUT--RED WIRE	12 MIN
230 V POWER SUPPLY	TOP JUNCTION BOX	WHITE	WIRE NUT--WHITE WIRE	12 MIN
REMOTE PUMP	TOP JUNCTION BOX	BARE/GRN	WIRE NUT--GREEN WIRE	14 MIN
REMOTE PUMP	TOP JUNCTION BOX	BLACK	TERMINAL BLOCK 7	14 MIN
REMOTE PUMP	TOP JUNCTION BOX	WHITE	TERMINAL BLOCK 2	14 MIN
THERMOSTAT	IGNITION CONTROL	BARE/GRN	GROUND TERMINAL	14 MIN
THERMOSTAT	IGNITION CONTROL	WHITE	TERMINAL T1 SCREW	18 MIN
OPT. DRAFT BOOSTER	TOP JUNCTION BOX	RED	TERMINAL T2 SCREW	14 MIN
OPT. DRAFT BOOSTER	TOP JUNCTION BOX	BLACK	TERMINAL BLOCK 6	14 MIN
EXHAUST FLOW SWITCH	TOP JUNCTION BOX	WHITE	TERMINAL BLOCK 2	14 MIN
EXHAUST FLOW SWITCH	BURNER JUNCTION BOX	BARE/GRN	GROUND TERMINAL	14 MIN
EXHAUST FLOW SWITCH	BURNER JUNCTION BOX	ORANGE	TERMINAL BLOCK 17	18 MIN
EXHAUST FLOW SWITCH	BURNER JUNCTION BOX	ORANGE	TERMINAL BLOCK 18	18 MIN

SHORTENED SEQUENCE OF OPERATION	
SEE INSTALLATION & OPERATION INSTRUCTIONS FOR FULL DETAILS	
<ol style="list-style-type: none"> WITH POWER SUPPLIED AND DISCONNECT SWITCH "ON", OIL HEATERS PREHEAT OIL ON CALL FOR HEAT. THERMOSTAT CLOSES CAUSING IGNITION CONTROLLER TO ENERGIZE BURNER MOTOR, ATOMIZING AIR COMPRESSOR, REMOTE OIL PUMP AND IGNITION TRANSFORMER. OIL IS IGNITED AND FLAME ESTABLISHED. 30 - 45 SECONDS AFTER FLAME IS ESTABLISHED, THE FAN CONTROL ACTIVATES AIR MOVING DEVICE(S). WHEN THERMOSTAT IS SATISFIED, POWER IS REMOVED FROM IGNITION CONTROLLER, DE-ENERGIZING BURNER MOTOR, ATOMIZING AIR COMPRESSOR AND REMOTE OIL PUMP. AIR MOVING DEVICE(S) CONTINUE TO OPERATE UNTIL THE HEAT EXCHANGER IS COOL (NOMINAL 3 MINUTES). IF IGNITION DOES NOT OCCUR WITHIN 15 SECONDS THE IGNITION CONTROLLER WILL LOCK DOWN ON THE RED RESET BUTTON FOR (4) SECONDS AND THEN RELEASING IT. DO NOT RESET MORE THAN ONE TIME! 	

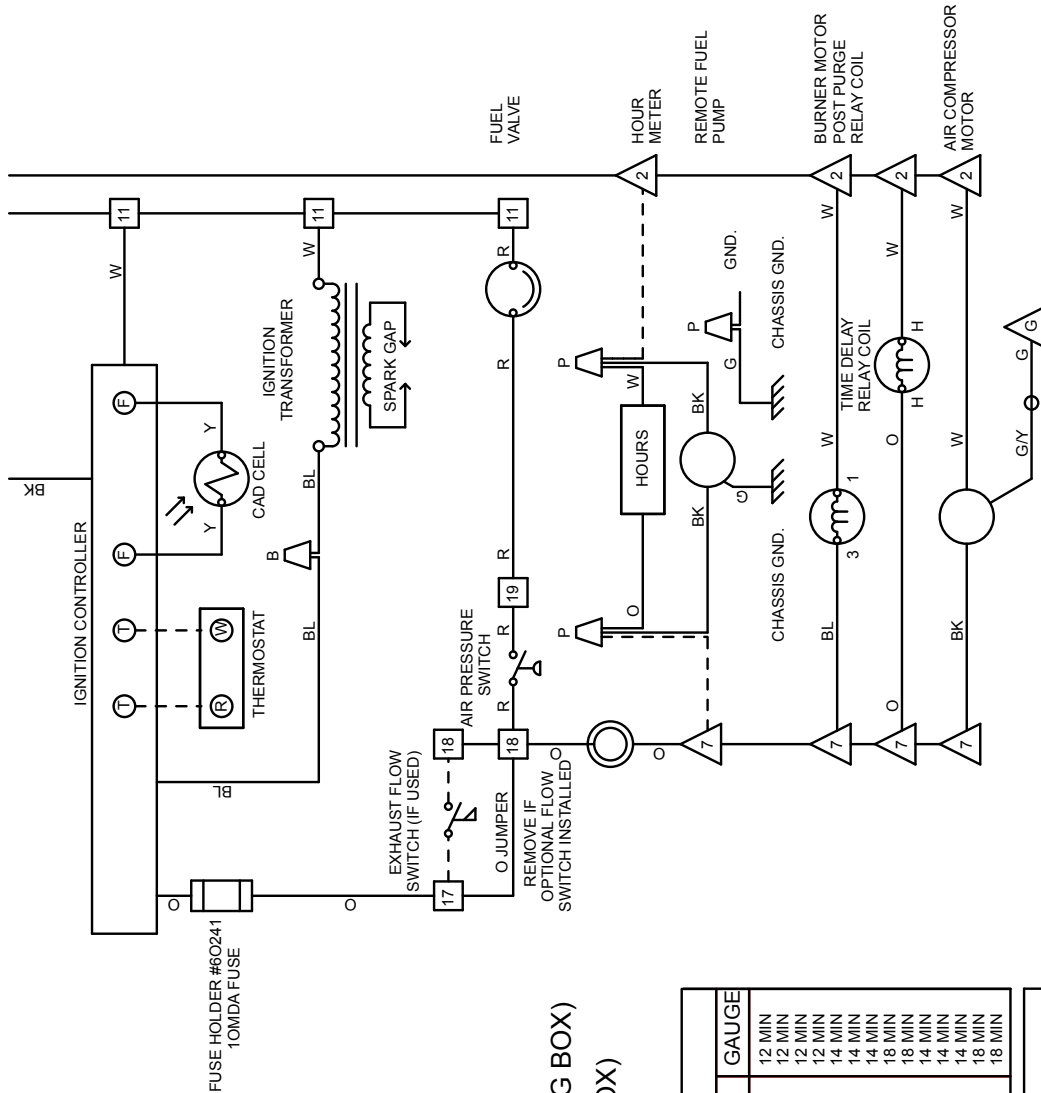

CAUTION: IF ANY OF THE ORIGINAL WIRE AS SUPPLIED WITH THE APPLIANCE MUST BE REPLACED, IT MUST BE REPLACED WITH WIRING MATERIAL HAVING A TEMPERATURE RATING OF AT LEAST 105°C. EXCEPT FOR HEATING ELEMENT, FAN CONTROL AND LIMIT WIRING WHICH MUST BE 150°C.

RV 325 DWG. #B-186385 REV. #7

Hour Meter / Cleaning Record

Cleaning Date	Meter Reading	Initials	Cleaning Date	Meter Reading	Initials

Index

A

Adjust Blower Speed 23
Air Band and Air Shutter Settings 22
Air for Combustion 6
Air Shutter 22

B

Backflow Sensor 36
Belt 27
Burner 29, 30
Burner Startup 19

C

Check Test - After Startup 21
Check Test - Prior to Startup 19
Cleaning Record 50
Clearances from Combustibles 7
Codes and Regulations 4
Combustion Chamber 27
Combustion Chamber/ Heat Exchanger 28
Compressed Air Filter 29
Configuration 16
Contact 52
Cylinder 33

D

Discharge Air Temperature 22
Discharge Configuration 16
Discharge Duct 17
Discharge Line 11
Draft Inducer 14
Draft Regulator 15
Inlet Air Duct 17
Duct Opening Dimensions 17

E

Electrode Adjustment 31
Electrodes 29, 30
End Cone 29, 30
Exterior Surfaces 33

F

Flue Pipe 27
Fuel Line Assembly 30, 32
Fuels 5
Fuel Tank 8

H

Hazard Intensity Levels 5
Hazardous Atmosphere 5
Heater Shutdown 23
Heater Stand 12
Heat Exchanger 27
High Altitude Installation 8

I

Indicator Lights 36
Inspecting the Heat Exchanger/ Combustion Chamber 28
Installer 52
Introduction 4

L

Tank Warning Label 23
Automatic Circulating Air High Limit 44
Super High Limit 44
Limit Controls 44
Location of Components 38

M

Maintenance Procedures 25
Maintenance Requirements 24
Maintenance Schedule 24
Measuring Draft Over Fire 21
Mounting the Heater 12

N

Non-Compliance 6
Nozzle 29, 30

O

Oil Burner Troubleshooting 36
Oil Delivery System 45
Oil Heat Exchanger 38
Operation 34

P

Parts Carton 6, 7
Heater Placement 7
Main Power 18
Pump Power 18
Power Installation 18
Pre-Heater System 32
Priming and Checking the System 19
Priming and Leak Check 19
Pump 8, 9

R

Recharging the Suction Line 26
Blower Time Delay Relay 44
Return Line 10

S

Internal Pump Screen 25
Secondary Heat Source 5
Service 34
Spark Electrodes 31
Burner Oil Strainer 26
Start-Up 19

Start-Up Procedure 20
Suction Line 10
Supply Line Connections and Support 11
Supply Line Filter 25
Supply Lines 8
Supply Lines Installation 10
Suspension 12
System Check 19

T

Thermostat 18
Troubleshooting Chart Guide 37
Typical Installation 11

U

Unpacking 6
Use 4

V

Vacuum Gauge 23, 24
Venting 5, 12
Vent Pipe Diameter 14
Vent System 13
Vertical Louvers 17

W

Warnings 5
Warranty 4
Weight 12
Wiring Diagram 46, 48

**CAUTION: DO NOT TAMPER WITH THE UNIT OR CONTROLS.
CALL YOUR SERVICE PERSON.**

INSTALLER MUST COMPLETE THE FOLLOWING:

Installer:

Name _____
Company _____
Address _____

Phone _____

Distributor (company from which the unit was purchased):

Company _____
Contact _____
Address _____

Phone _____

Model _____ Serial No. _____ Date of Installation _____

SPECIFIC INSTALLATION NOTES: (i.e. Location, Amps, Temperature, Voltage, Adjustments, Warranty, etc.)

BUILDING OWNER OR MAINTENANCE PERSONNEL:

For service or repair

- **Contact the installer listed above.**
- **If you need additional assistance, contact the Reznor Distributor listed above.**
- **For more information, contact your Reznor Representative by calling (800) 695-1901.**

**Reznor, LLC
150 McKinley Avenue
Mercer, PA 16137**

REZNOR®

Form I-RV, P/N 202657 R11, Page 52



www.ReznorHVAC.com; (800) 695-1901

©2015 Reznor, LLC. All rights reserved.

Trademark Notes: Reznor® is registered in at least the United States. All other trademarks are the property of their respective owners.

0515 Form I-RV (Version C.2)