



Installation Instructions Hurst Pro-Matic 2 Truck Shifter

Fits most 2WD & 4WD Truck Applications
GM TH 350/400 / Ford C4/C6 / Mopar Torqueflite A727/A904
Catalog# 3838510

WORK SAFELY! For maximum safety, perform this installation on a clean, level surface and with the engine turned off. Installation of this shifter requires working underneath vehicle. Raise front of vehicle by lifting at points specified by the vehicle manufacturer. Place blocks or wedges in front of and behind both rear wheels to prevent movement in either direction. **DO NOT USE A BUMPER JACK FOR SUPPORTING VEHICLE.**

CAUTION: To avoid any possibility of bodily injury or damage to vehicle, do not attempt installation until you are confident that the vehicle is safely secured and will not move.

IMPORTANT

1. All adjustments must be made with shifter and transmission in "Park", "Neutral", and "Low" gear positions.
2. Adjustments are critical and must be precise.
3. Do not mix components (all parts including shifter cable must be genuine Hurst components provided with kit).
4. If a shifter is removed and re-installed, adjustments must be checked and re-adjusted, if necessary.
5. When routing cable avoid sharp bends. Provide large full loops (if needed) for smooth shifting and long cable life. Avoid routing cable near exhaust pipes as heat from the exhaust system will melt cable casing. (Permanent damage of cable will result).
6. Always check cable for freedom of movement before connecting to shifter and transmission control arm.

Failure to comply with any of the above may result in malfunction of shifter operation. Damage to cable due to sharp bending, kinking, or excessive heat is not covered by Warranty.

These instructions detail the installation of the Hurst Quarter Stick Shifter for GM Powerglide 2 speed transmission with both forward and reverse pattern valve bodies and GM Turbo TH 350/400 3 Speed transmission with a reverse pattern valve body only. Please refer to the specific instructions for your particular application for detailed information. See the illustration on page 4 for changing from 2 speed to 3 speed operation.

The shifter can be mounted directly to the floor with the four sheet metal screws supplied.

CONSOLE INSTALLATION

1. Measure depth from top of shifter to below top of console.
2. Adjust points of divider to measure depth.
3. Scribe contours of floor along the side of console as shown. Maintain divider in a perpendicular plane while scribing.
4. Trim portion below scribed line away. Fasten console to shifter with two #8 x 1-3/4" Phillips Head screws.

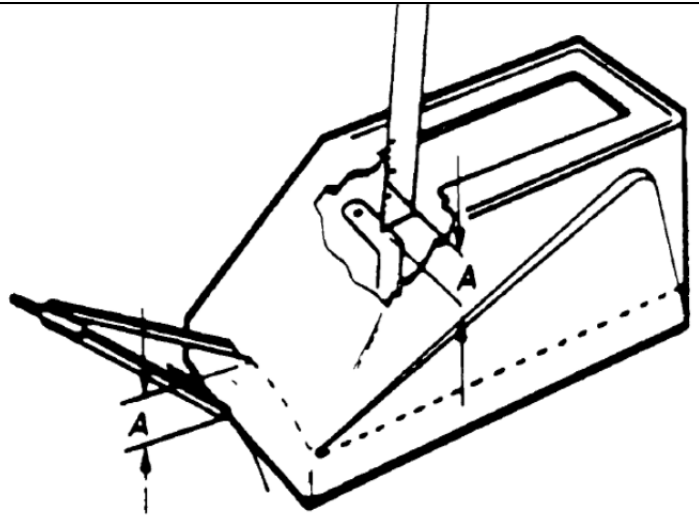

INSTALLATION OF PRO-MATIC 2 SHIFTER

1. Disconnect negative (-) battery cable.

Caution: when removing or connecting the battery cable terminal, use care to avoid intermittent contact (arcing or sparking) between battery post and terminal end. This generates voltage spikes that can damage sensitive ECM (Electronic Control Module) components or memory circuits.

2. Turn ignition key to "Unlock" position on steering column if equipped and place factory shifter in "Neutral" position.

Column shift lever: remove drive pin that fastens shifter lever to column, then remove lever from steering column. Disconnect and remove shift linkage rod from steering column inside engine compartment and linkage rod attached to transmission control arm.

3. Place Pro-Matic 2 Shifter stick in "Neutral" position and remove shifter knob. Lift console up and off. Remove one (1) #8 x 3/4" Phillips head screw that fastens chrome console cover to console and separate.

4. Position shifter in a desired location on floor allowing clearance for seat travel and shifter stick travel when shifting into "Park" position. Cut a small section of carpet or floor matting where shifter assembly will mount to floor (make sure there are no wires underneath carpet). Place shifter assembly in selected location, mark and center punch four (4) mounting holes. Drill through floor using a 9/32" drill bit. Deburr holes with a file and sand with emery cloth. (See Figure 1).

FRONT OF SHIFTER

TOP VIEW OF SHIFTER MOUNTING AND CABLE MOUNTING HOLE PATTERNS

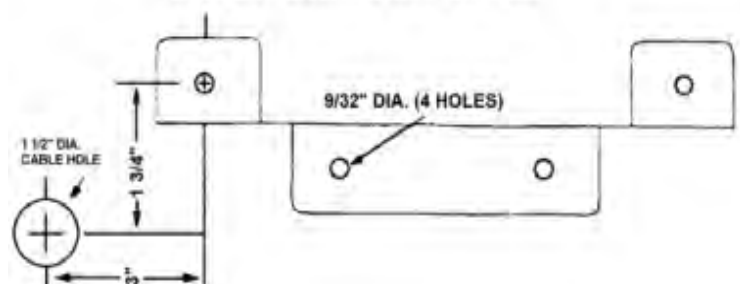

Figure 1

5. If necessary, mark and cut a slit in the carpet to accommodate shifter cable. Using a hole saw or other suitable tool, make a 1-1/2" diameter hole in flooring 3" in front of forward mounting hole and 1-3/4" to the left of forward mounting hole to accommodate shifter cable (See Figure 1). For some vehicles the 3" dimension may be less. Deburr hole with a file and sand with emery cloth. Install rubber grommet into 1-1/2" diameter hole.

6. Attach shifter assembly to floor using four (4) 1/4"-20 x 1" hex head bolts, 1/4" flatwashers, and 1/4"-20 hex nuts. Tighten securely. Install two (2) U-Type clip fasteners (Item #10) onto front and rear console mounting tabs of shifter frame. When installing these clips be sure extruded side is underneath mounting hole facing downward. (Refer to Identification and Contents of Shifter Kit).

CABLE INSTALLATION

CAUTION: When installing shifter cable (Item #12), avoid sharp bends or kinks. Damage to cable due to sharp bending or kinking is not covered by warranty.

7. Remove 3/16" hex nut, two (2) rubber boots, two (2) 7/16" hex nuts, and two (2) internal tooth lockwashers from threaded end of shifter cable. Using tape, wrap the section of cable that rubber boots were covering so dirt or grease will not get embedded inside cable housing causing cable to scuff and bind. Insert cable from inside vehicle through rubber grommet in floor. Route cable so there are no sharp bends that would make the shifter hard to operate. Be sure cable clears all exhaust pipes by at least 1-1/2" (Refer to Figure 2).

FIGURE 2

SHIFTER CABLE ROUTING

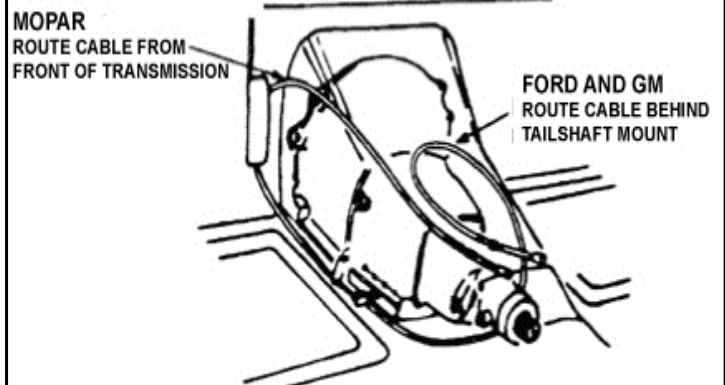

Note: Use tie straps or clamps to secure shifter cable away from the exhaust pipes and engine. Cable end with mounting tab attached (shifter assembly end) must slip into slotted opening on shifter frame. Position tab on the inside of shifter frame and fasten using 1/4"-20 x 3/4" hex bolt and 1/4" hex nut. Slide cable end onto cotter pin.

Proceed to section that applies to the model and transmission of your vehicle.

GENERAL MOTORS

Turbo-Hydramatic 350 and 400

1. Remove backdrive linkage rod and stock transmission arm from gear selector shaft on transmission using a 9/16" socket and replace with Hurst transmission arm PT. 1058561 re-using stock bolt or nut. Transmission arm must be installed with round hole down and bend in arm positioned away from transmission. (See Figure 4).

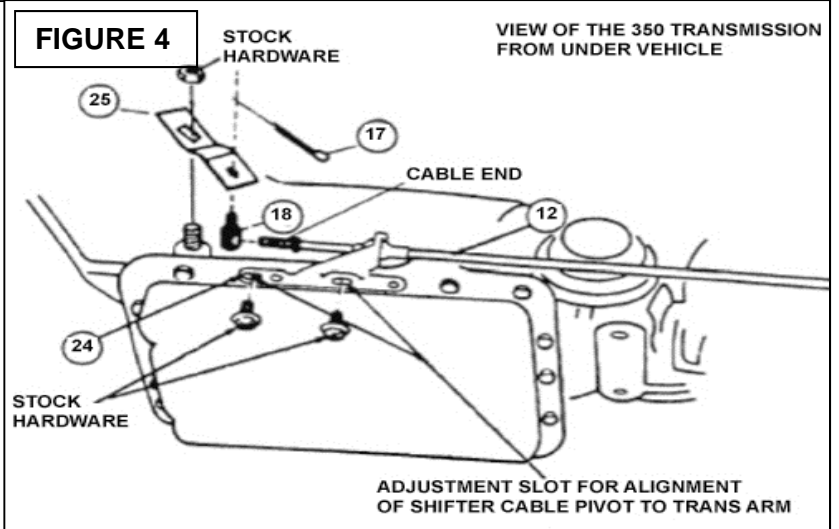

IMPORTANT

VEHICLES EQUIPPED WITH STEERING COLUMN LOCK

In some applications the stock backdrive linkage system that locks the steering column and shifter in "Park" position may be retained depending on the stock transmission arm configuration.

One side of the stock transmission arm must have a flat unobstructed surface in order to be used and retain the factory backdrive linkage system. Carefully position Hurst transmission arm on top of or behind the stock transmission arm as illustrated. (See Figure 3). The alignment of the mounting slots in both transmission arms is very important. With slots aligned, clamp arms together and weld along indicated lines. Allow transmission arm to cool, and replace onto transmission gear selector shaft using stock bolt or nut. Re-install backdrive linkage.

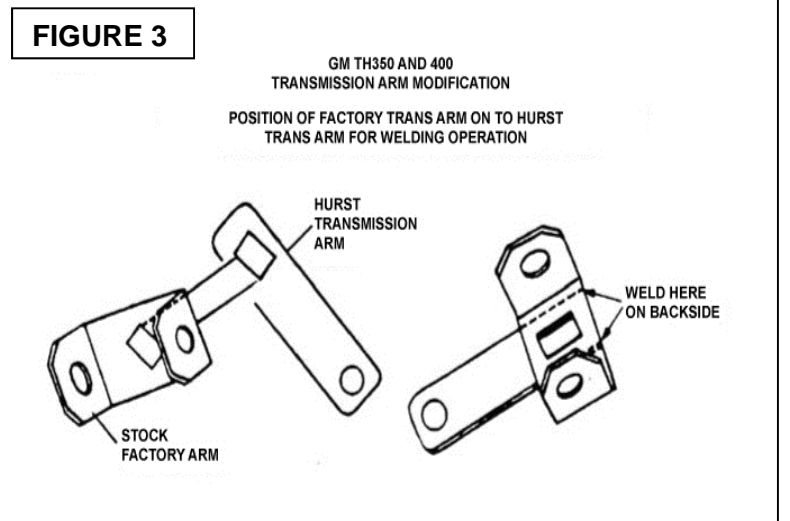

Note: If the backdrive linkage system is not going to be retained, the linkage rod lever (located inside engine compartment on steering column) must be secured in the upward position. This will allow ignition key to be turned to "Lock" position and withdraw freely out of lock.

2. Remove the two (2) center transmission oil pan bolts (using 1/2" socket) from left (driver) side of transmission as indicated. Attach Hurst cable bracket Pt. 117 4778Z to transmission oil pan re-using stock bolts. Do not overtighten. (Refer to Figure 4).

Note: Hurst shifter cable bracket features slotted mounting holes to allow for adjustment of cable forward or rearward.

3. Remove tape from cable and re-install rubber boots. Place shifter cable into mounting bracket on transmission oil pan and secure using two (2) internal tooth lockwashers and two (2) 7/16" hex nuts supplied with cable.

4. Be sure shifter is in "Neutral" position. Check and be sure transmission arm on gear selector shaft is also in "Neutral" position. Thread cable pivot onto end of shifter cable. Adjust cable pivot until it slides freely into hole in transmission arm. When properly adjusted, lock cable pivot in place using 3/16" hex nut. Insert cable pivot end into transmission arm so pivot end is facing outward away from transmission. (See Figure 4 &7). Temporarily install cotter pin.

MOPAR

TORQUEFLITE A-727 & A-904

1. The stock backdrive linkage that locks shifter stick in "Park" position cannot be retained. Linkage rod lever (located inside engine compartment on steering column) must be secured in the upward position. This will allow ignition key to be turned to "Lock" position and withdraw freely out of lock.

2. Remove throttle lever located just above transmission arm by removing the bolt and nut, pry lever off the shaft using a flatblade screwdriver. Remove linkage and stock transmission arm. Install Hurst Transmission arm Pt. 105 8564 using the 1/4" x 1-1/2" hex bolt (Item #19), 1/4" split lockwasher, and 1/4" hex nut supplied. Re-install throttle lever and linkage onto shaft. Check throttle lever to be sure it operates freely. (See Figure 5).

Figure 5

MOPAR INSTALLATIONS A-727 & A-904 TORQUEFLITE

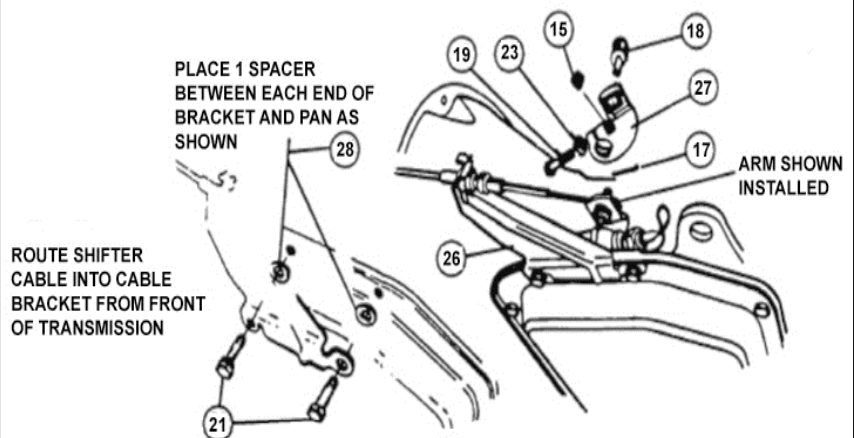

3. Two (2) transmission oil pan bolts (driver side) directly below transmission arm must be removed. Install cable bracket Pt. 117 8563, two (2) spacers, and two (2) 5/16"-18 x 3/4" hex head bolts supplied. If transmission has a cast aluminum oil pan, spacers may not be needed.

4. Remove tape from cable and re-install rubber boots. Place shifter cable into mounting bracket on transmission oil pan and secure using two (2) internal tooth lockwashers and two (2) 7/16" hex nuts supplied with cable. (See Figures 2 and 5). It may be necessary to slightly bend the transmission cooling lines to attain clearance for cable.

5. Make sure shifter is in "Neutral" position. Check and be sure transmission arm on gear selector shaft is also in "Neutral" position. Thread cable pivot onto end of shifter cable. Adjust cable pivot until it slides freely into hole in transmission arm. When properly adjusted, lock cable pivot in place using 3/16" hex nut. Insert cable pivot into transmission arm so pivot end is facing outward away from transmission. (See Figure 5). Temporarily install cotter pin.

FORD

C-4 & C-6

1. The stock backdrive linkage that locks shifter stick in "Park" position cannot be retained. Linkage rod lever (located inside engine compartment on steering column) must be secured in the upward position. This will allow ignition key to be turned to "Lock" position and withdraw freely out of lock.

2. Remove linkage and lever that is connected to the downshift lever shaft. Shift linkage rods should be disconnected and discarded. The original equipment neutral safety and back-up light switch that are found on some Ford transmissions should be disconnected and discarded. (See Figure 6).

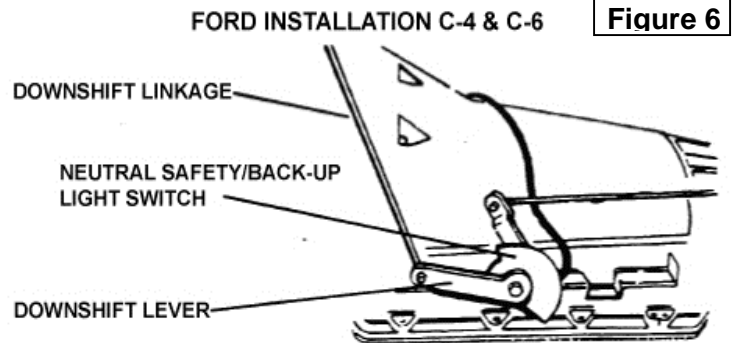

3. The stock transmission arm must be modified in order to install Hurst transmission arm Pt. 105 8559. Lower section of stock transmission arm must be removed (See Figure 6A) to provide clearance for Hurst transmission arm. Using a hacksaw, cut shaded section of transmission arm off so remaining arm is completely flat. Install Hurst transmission arm onto stock transmission arm pointing downward, with bend in arm away from transmission. Use 1/4" x 1-1/2" hex bolt, 1/4" split lockwasher, and 1/4" hex nut to secure Hurst transmission arm in place. Re-install downshift lever, make sure o-ring is in position before installing lever onto shaft. Downshift lever must move freely.

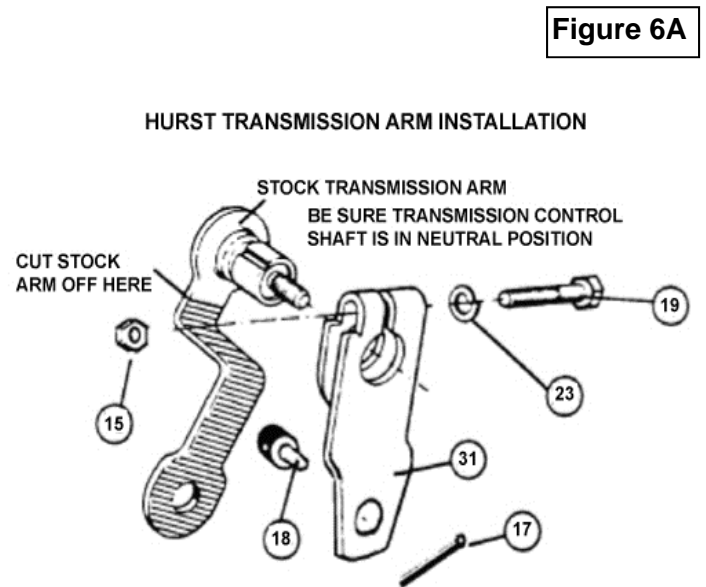

4. C-4: Two (2) lower bolts (E) on the rear servo cover (F), must be removed. Install Hurst cable bracket Pt. 117 8558 onto servo cover, re-using factory bolts and tighten securely.

(See Figure 6B).

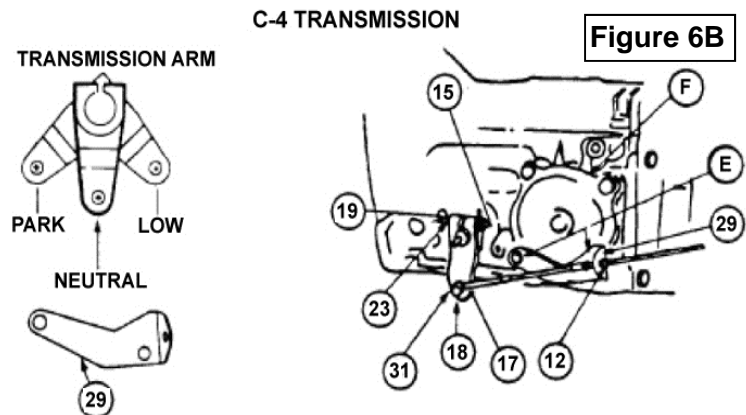

C-6: Two (2) transmission oil pan bolts at the left rear corner must be removed to install the Hurst cable bracket and two (2) spacers. Install the cable bracket onto the oil pan using the 5/16"-18 x 3/4" bolts (supplied). (See Figure 6C). If transmission has a cast aluminum oil pan, spacers may not be necessary.

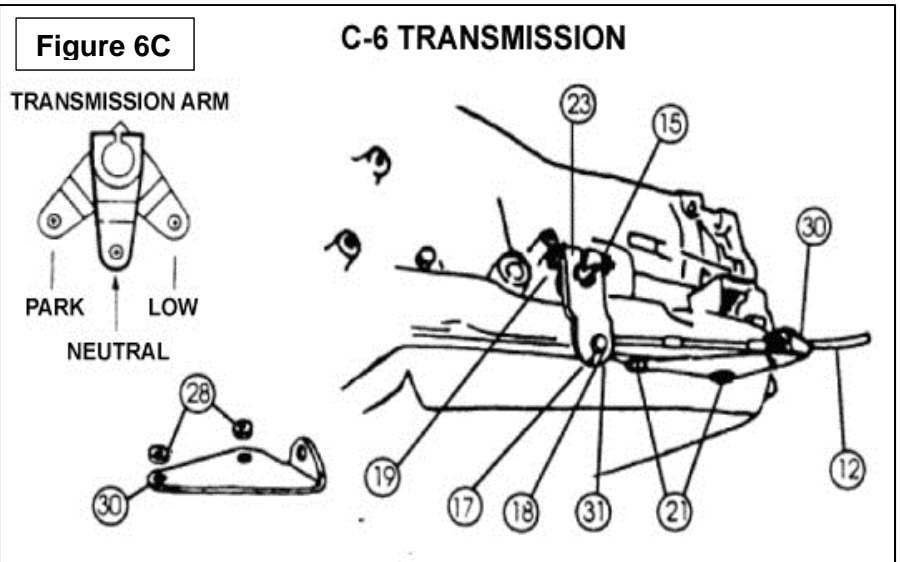

5. Remove tape from cable and re-install rubber boots. Place shifter cable into mounting bracket on transmission oil pan and secure using two (2) internal lockwashers and two (2) 7/16" hex nuts supplied with cable.

6. Make sure shifter is in "Neutral" position. Check and be sure transmission control arm gear selector shaft is in "Neutral" position. Thread cable pivot onto end of shifter cable. Adjust cable pivot until it slides freely into hole in transmission arm. When properly adjusted, lock cable pivot in place using 3/16" hex nut. Insert cable pivot end into transmission arm so pivot end is facing outward away from transmission. (See Figure 6 & 7). Temporarily install cotter pin.

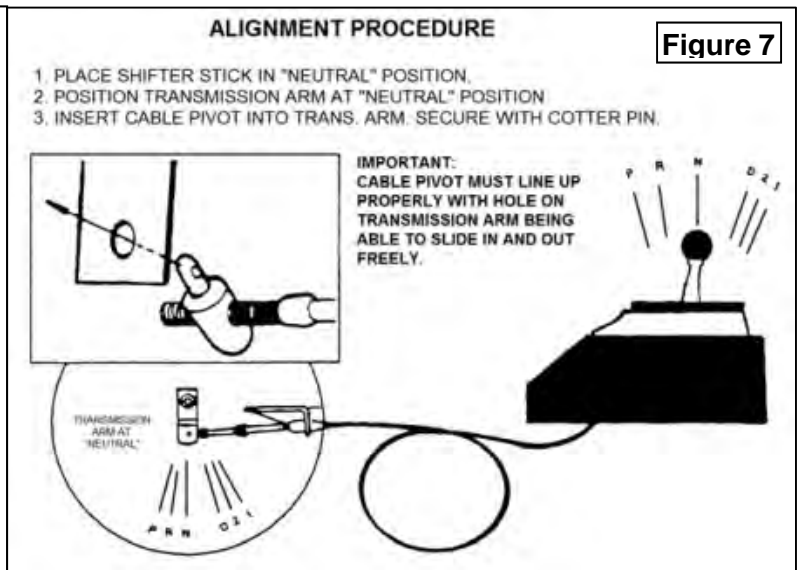

NEUTRAL/PARK START WIRING CONNECTION (EXCEPT MOPAR APPLICATIONS)

Important: The Pro-Matic 2 shifter uses an electrical neutral/park start switch that replaces the original equipment neutral safety switch on most Chevy, GMC, Ford, and Mopar applications. The original neutral safety switch is typically located at the lower end of steering column. For your particular application refer to the vehicle manufacturer's service manual for the correct location.

1. Pre-wire Hurst neutral/park start switch (front switch located on shifter assembly) using two (2) female crimp connectors (Item #22) and two (2) suitable lengths of 16 gauge insulated automotive grade wire (not supplied). Strip 1/4" of insulation off each end of wire and firmly crimp female connector onto one end of each wire. Push female connectors onto switch terminals. Route wiring away from shifter assembly so it will not interfere with internal moving parts. (Refer to Figure 8).

2. Locate wire connected to starter solenoid terminal marked "S" and trace to original equipment neutral start switch. Locate wire connected to "Solenoid" terminal of ignition switch and also trace to original neutral start switch. Disconnect both wires leading to original equipment switch and connect to Hurst neutral/park start switch wire leads. Use correct size insulated electrical butt connectors to properly connect the wires together. (Refer to Figure 8).

Note: If Pro-Matic 2 shifter is used in an application without an original equipment neutral/park start switch, locate wire connecting "S" terminal on starter solenoid to "Solenoid" terminal of ignition switch. Cut this wire and splice in the Hurst neutral park/start switch.

WARNING: Failure to wire and connect switch correctly can allow engine to start in "Drive" or "Reverse" causing unexpected vehicle motion and possible bodily injury or property damage.

BACK-UP LIGHT SWITCH WIRING CONNECTION (EXCEPT MOPAR 1969-LATER APPLICATIONS)

Note: For your particular application refer to the vehicle manufacturer's service manual for the correct location of original equipment back-up light switch.

1. Pre-wire Hurst back-up light switch (rear switch located on shifter assembly) using two (2) female crimp connectors and two (2) suitable lengths of 16 gauge insulated automotive grade wire (not supplied). Strip 1/4" of insulation off each end of wire and firmly crimp female connector onto one end of each wire. Push female connectors onto switch terminals. Route wiring away from shifter assembly so it will not interfere with internal moving parts (See Figure 8).

2. Locate wire lead connected to back-up lights and trace to the original equipment back-up light switch. Disconnect both wires leading to the back-up light switch and connect to Hurst back-up light switch wire leads. Use correct size insulated electrical butt connectors to properly connect the wires together.

Note: one wire lead from the Hurst back-up light switch must have 12 volt power when the ignition key is in the "On" position. (See Figure 8).

Figure 8

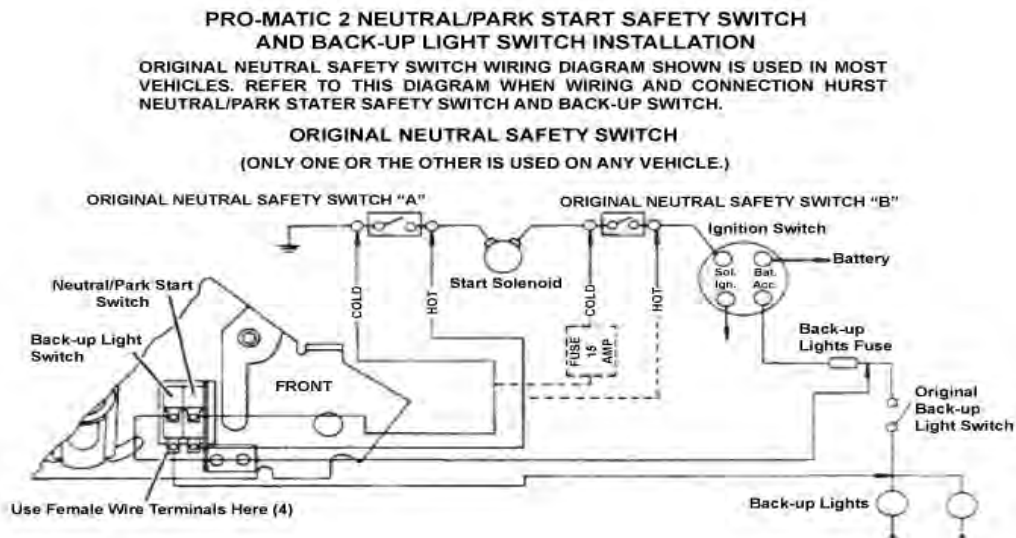

Applications

1969-Later

The original equipment factory back-up light switch is located on the transmission. No additional wiring necessary.

SHIFT INDICATOR LAMP SOCKET WIRING CONNECTION

Use a suitable length of 22 gauge insulated automotive grade wire (not supplied). Strip 1/4" of insulation off each end of wire. Connect lead wire from light assembly to this wire using the correct size electrical butt connector. Connect other end of wire to electrical circuit of instrument panel lights.

Important: The shifter assembly must have a good chassis "ground" for indicator lamp to work properly.

SHIFTER OPERATION

Caution: Before testing shifter operation, it is recommended that vehicle be placed back on the ground, parking brake applied, and wheels blocked. Vehicle should be parked in a safe location for testing. Be sure no one is in front of or behind during testing.

Apply brake pedal pressure while testing. Familiarize yourself with the operation of this shifter by moving the shifter stick backward and forward through entire shift pattern (See Figure 9). Move stick through each gear selection, counting positions as you feel them: P-R-N-D-2-1

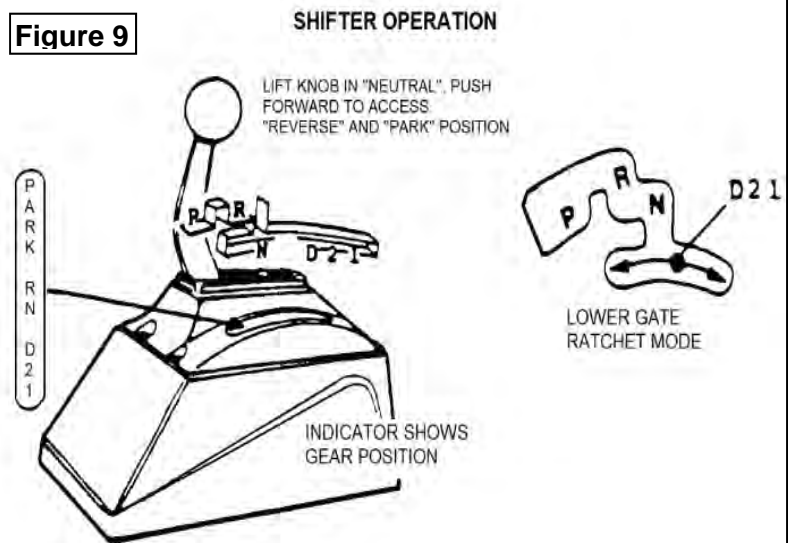

Cable pivot attached to transmission control arm should be checked in "Park", "Neutral, and "Low" gear positions to be sure pivot slides freely "IN" and "OUT" of transmission arm. Move shifter stick into "Low" gear and check adjustment underneath vehicle by removing cotter pin and cable pivot from transmission arm. Check to be sure that transmission is FULLY ENGAGED in "Low" gear. When cable adjustment is correct, shifter will engage "Park" and "Low" gears completely. Once adjustment is made, secure cotter pins on either end of shifter cable and be sure all adjustment bolts and nuts are tightened securely.

WARNING: Correct cable adjustment is mandatory to insure that when shifter is in "Park" position, transmission is also fully into the "Park" detent. Failure to adjust cable correctly could result in unexpected vehicle motion when shifter is in "Park" or "Neutral" positions.

STARTER MOTOR AND BACK-UP LIGHT TEST OPERATION

We recommend disconnecting the “batt” wire from distributor so engine will crank but not start. Reconnect negative (-) battery cable. With the shifter in “Park” position and brake pedal pressure applied, test starter motor operation in every gear position of the shift pattern. The starter must operate in “Park” and “Neutral” gear positions ONLY. If starter operates in any other gear position, re-check wiring to be sure connections and adjustments of switches are correct. Test operation of back-up lights, they should operate in “Reverse” only. Turn “On” instrument panel and check illumination of gear indicator lamp.

Note: The Hurst neutral/park start switch and back-up light switch are pre-adjusted from the factory for your convenience. If adjustment is needed, loosen the screw located at the top of switch mounting bracket. Pivot switch assembly inward until the required contact is made between switch and actuator plate. Shifter must be in the correct gear selection: Park, Neutral, or Reverse when making this adjustment.

CONSOLE INSTALLATION

Note: In some applications shifter console must be trimmed to fit the contour of floor tunnel.

Place console over shifter assembly and hold it level with shifter. For proper installation, the inside of console top must rest on the two (2) mounting tabs of shifter frame.

Measure distance “A” from underside of console to the console mounting tabs on shifter assembly (See Figure 10). Using a pair of dividers set to the dimension of distance “A”, touch one end of dividers to console and other end to floor tunnel. Drag along floor tunnel and against console scribing a line on the console to match the contour of floor tunnel by keeping dividers perpendicular to floor tunnel.

Figure 10

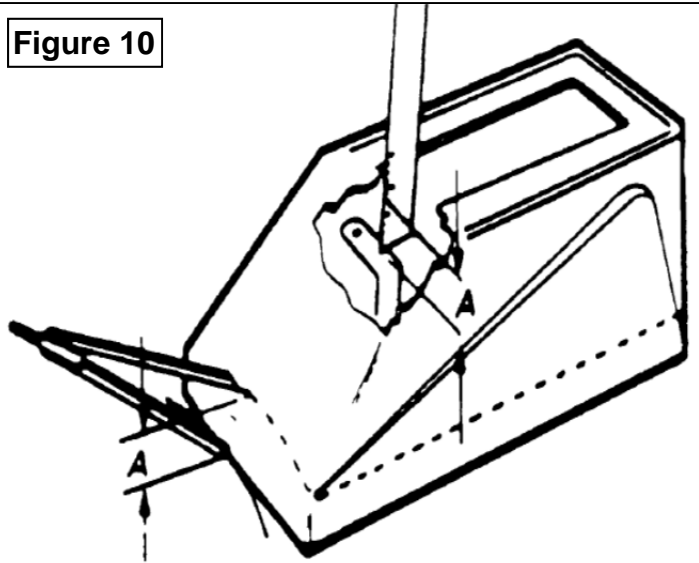

Using a utility knife, carefully score a firm cut over the line scribed into console. To prevent any unnecessary cracking, it is recommended that console be at room temperature before cutting or trimming. Remove any burrs or rough edges with a small file.

Insert indicator lens into chrome console cover and place onto console, fasten using two (2) #8 x 3/4” Phillips head screws. (Refer to Identification and Contents of Shifter Kit for correct placement of indicator lens and screws).

Place console onto shifter assembly and fasten to mounting tabs on shifter frame using two (2) #8 x 1-3/4” Phillips head screws. Slide rubber boot over shifter stick and work it into the chrome console cover. Thread shifter knob onto stick, turn to desired position and tighten jam nut against knob.

GENERAL MOTORS VEHICLES EQUIPPED WITH STEERING COLUMN LOCK

Once all adjustments have been made and shifter functions properly, check operation of steering column lock. It must operate in "Park" position ONLY. It is very important that the column lock be adjusted correctly so that when shifter is placed into "Park" position, ignition key can be turned to "Lock" position. Steering wheel should lock and key should withdraw freely out of lock. The shifter then must not be able to move in any other gear position. If the shifter can be moved to other gear positions, column lock is not adjusted correctly and must be re-adjusted.

SHIFTER OPERATION

GEAR SHIFT PATTERN CHANGES / UPPER GATE MODE - GEAR SELECTION

The upper gear selection gate of the shifter operates "Park" and "Reverse". When in "Park" position, the shifter stick must be lifted to clear the safety stop between "Park" and "Reverse", then pulled straight back to engage "Reverse". Once in "Reverse", the handle will drop down slightly and shifter is ready to be pulled straight back to "Neutral". When "Neutral" is engaged the stick will drop again and enter the lower gate (ratchet mode) of shifter. (See Figure 9).

LOWER GATE RATCHET MODE - GEAR SELECTION

The lower gear selection gate of the shifter operates "Neutral", "Drive 3", "Drive 2", and "Drive 1" (low gear). The shifter stick ratchets back and forth from "Neutral" to "Drive 1".

DOWNSHIFTING

Park to Reverse	Lift stick, pull back to next detent for "Reverse". Stick will drop down slightly.
Reverse	Pull back to next detent for "Neutral". Stick will drop down again.
Neutral to Drive 3	Push down then pull back to stop position and release for "Drive 3".
Drive 3 to Drive 2	Pull back again to stop position and release for "Drive 2".
Drive 2 to Drive 1	Pull back again to stop position and release for "Drive 1".

UPSHIFTING

Drive 1 to Drive 2	Push stick forward to stop position and release for "Drive 2".
Drive 2 to Drive 3	Push stick forward again to stop position and release for "Drive 3".
Drive 3 to Neutral	Push stick forward to stop position and release for "Neutral".
Neutral to Reverse	Lift stick upward, push forward to next detent for "Reverse".
Reverse to Park	Lift stick upward, push forward to stop position for "Park".

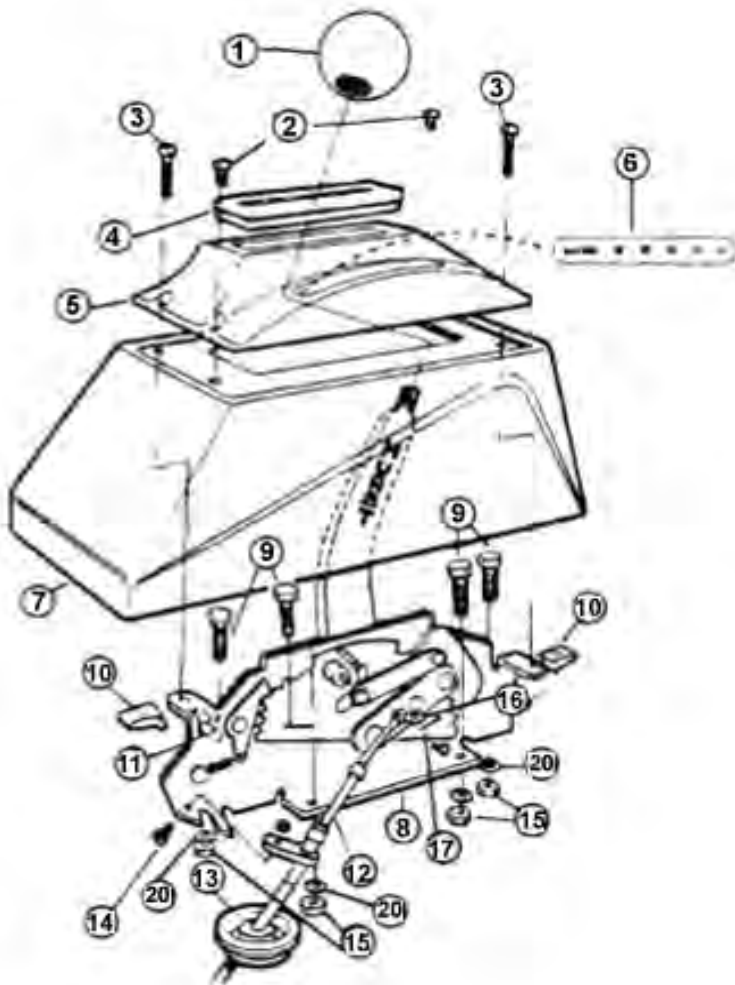

TOOLS REQUIRED FOR INSTALLATION

2 or 4 Automotive Support Stands
 Car Ramps
 1-1/2" Hole Saw
 9/32" Drill Bit
 Tin Snips
 Hacksaw (Ford Only)
 Hammer
 File
 Center Punch
 Wire Strippers
 Wire Crimping Tool
 1/8" Drift Punch
 12-Volt Test Light or Voltmeter
 Electric Drill
 Tape Rule
 Electrical Tape
 Pliers
 Flat Blade Screwdriver
 Phillips R Tip Screwdriver
 Ratchet-3/8" Drive
 10" long Extension-3/8" Drive
 7/16" Socket - 3/8" Drive
 1/2" Socket - 3/8" Drive
 9/16" Socket - 3/8" Drive
 3/8" Wrench-Open End
 7/16" Wrench-Open End
 11/16" Wrench-Open End
 Fluorescent Work Light

CONTENTS OF SHIFTER KIT

1. Shifter Knob	1630064
2. Phillips Head Sheet Metal Screw # 8 x 3/4"	97093105 (2)
3. Phillips Head Sheet Metal Screw #8 x 1-3/4"	97093106 (2)
4. Rubber Boot	1148550
5. Console Cover	1958551
6. Indicator Lens	1690005
7. Console	1298554
8. Shifter Assembly	3830510
9. Hex Head Bolt 1/4"-20 x 1"	97080969 (4)
10. U-Type Clip Fastener 1/4"-20 x 3/4"	97093081 (2)
11. Indicator Light Assembly	1660004
12. Shifter Cable	5008555
13. Rubber Grommet 1-1/2" Diameter	97093109
14. Hex Head Bolt 1/4"-20 x 3/4"	97090029
15. Hex Nut 1/4"-20	97000910 (6)
16. Flat Washer 3/16" I.D.	97000905
17. Cottern Pin 1/16"	97093086 (2)
18. Cable Pivot	97X93089
19. Hex Head Bolt 1/4"-20 x 1-1/2"	97000913
20. Flat Washer 1/4" I.D.	97000818 (4)
21. Hex Head Bolt 5/16"-18 x 3/4"	97000416 (2)
22. Female Wire Connector	2527600 (4)
23. Split Lockwasher 1/4" I.D.	97090082

GENERAL MOTORS

3-SPEED TURBO-HYDRAMATIC 350 & 400

24. Bracket-Shifter Cable TH 350 & 400	1174778Z
25. Transmission Arm TH 350 & 400	1058561

MOPAR

3-SPEED TORQUEFLITE A-727 & A-904

26. Bracket-Shifter Cable A-727 & A-904	1178563
27. Transmission Arm A-727 & A-904	1058564
28. Spacers-Cable Bracket	97093092

FORD

3-SPEED TORQUEFLITE A-727 & A-904

29. Bracket-Shifter Cable C-4	1178558
30. Bracket-Shifter Cable C-6	1178557
31. Transmission Arm C-4 & C-6	1058559

IMPORTANT: RETAIN THESE INSTRUCTIONS FOR FUTURE REFERENCE

Technical Service

A highly trained technical service department is maintained by Hurst Performance to answer your technical questions, provide additional product information and offer various recommendations.

Technical service calls, correspondence, and warranty questions should be directed to:



Hurst Performance Products

(707) 544-4761

www.Hurst-Shifters.com