



# INSTRUCTIONS

-J03966

REV. 2011-12-01

## CUSTOM AUXILIARY FORWARD LIGHTING KIT

### GENERAL

#### Kit Number

69818-06, 68000042

#### Models

This Custom Auxiliary Lighting Kit adds lamps and turn signals to 2006 and later FLHX model motorcycles.

#### Additional Parts Required

This kit does not include turn signals. You will be removing the original turn signals and re-positioning them onto the new auxiliary mount.

This kit does not contain sealed beams. See your local Harley-Davidson dealer for your sealed beam lights.

### WARNING

**The rider's safety depends upon the correct installation of this kit. Use the appropriate service manual procedures. If the procedure is not within your capabilities or you do not have the correct tools, have a Harley-Davidson dealer perform the installation. Improper installation of this kit could result in death or serious injury. (00333a)**

#### NOTE

*This instruction sheet references Service Manual information. A Service Manual for your model motorcycle is required for this installation and is available from a Harley-Davidson dealer.*

### Kit Contents

See Figure 8 and Table 1.

### REMOVAL

### WARNING

**To prevent accidental vehicle start-up, which could cause death or serious injury, disconnect battery cables (negative (-) cable first) before proceeding. (00307a)**

### WARNING

**Disconnect negative (-) battery cable first. If positive (+) cable should contact ground with negative (-) cable connected, the resulting sparks can cause a battery explosion, which could result in death or serious injury. (00049a)**

1. Disconnect the battery cables, negative (-) cable first.
2. Refer to the appropriate Service Manual and remove outer fairing from motorcycle.
3. Locate and disconnect the left and right turn signal connectors per procedure in appropriate Service Manual.

Refer to the appropriate Service Manual and remove left and right turn signal wires from pin connectors. Note location of wires before removal.

4. Remove original equipment turn signals per procedure in appropriate Service Manual and retain both left and right side turn signals.

#### NOTE

*Be sure to label or mark all wires before removing them to confirm proper installation and function of kit.*

5. Refer to appropriate Service Manual to locate turn signal connectors and auxiliary lamp connectors in preparation for auxiliary lamp kit installation.

### Auxiliary Lamp Assembly

#### NOTE

*The Auxiliary Lamp Kit will require basic assembly before installation on motorcycle.*

1. See Figure 1. Acquire lamp bracket (1), lamp housing (10), rubber washer (13), clamp block (14), lock washer (5), and nylon lock nut (4) and install lamp housing into lamp bracket. Retain with lockwasher and lock nut. Tighten to 14-18 ft-lbs (19-24 Nm). Repeat for other side.
2. Acquire grey wire from kit. Tie small knot in terminal end of wire approximately 3-4 inches from terminal to avoid wire getting pulled too far into housing during installation.

is02138

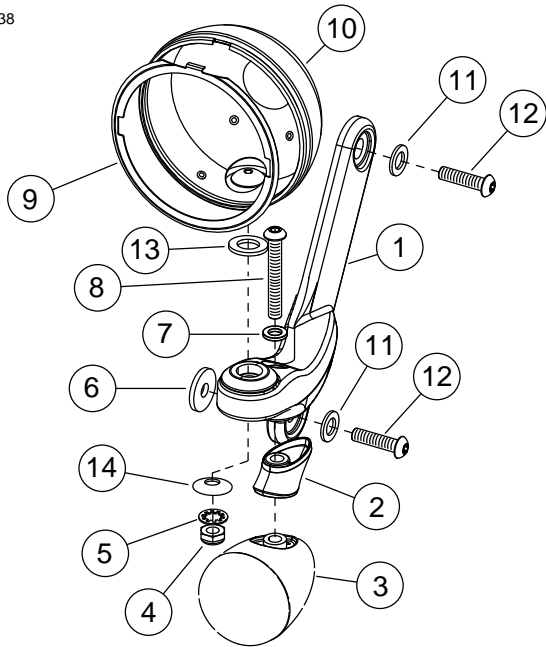

1. Lamp bracket
2. Directional standoff
3. Directional assembly (wires not shown)
4. Lock nut (nylon)
5. Lock washer
6. Washer
7. Lock washer (5/16 inch)
8. Hex socket screw, 5/16-18
9. Nest ring
10. Lamp housing
11. Washer
12. Screw, Torx head, 5/16-18 x 1-1/4
13. Rubber washer
14. Clamp block

Figure 1. Auxiliary Lamp Assembly (shown without wiring for assembly clarity)

is02139

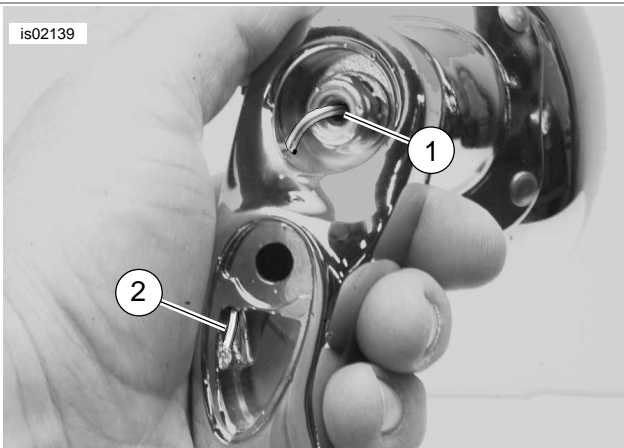

1. Auxiliary lamp housing
2. Socket housing

Figure 2. Lamp Wiring Routing Shown

3. See Figure 2. Insert bare end of grey wire through hole in mounting stud on lamp housing (1) and through larger passage in lamp bracket until knot in terminal end of wire bottoms in socket housing (2).

is02140

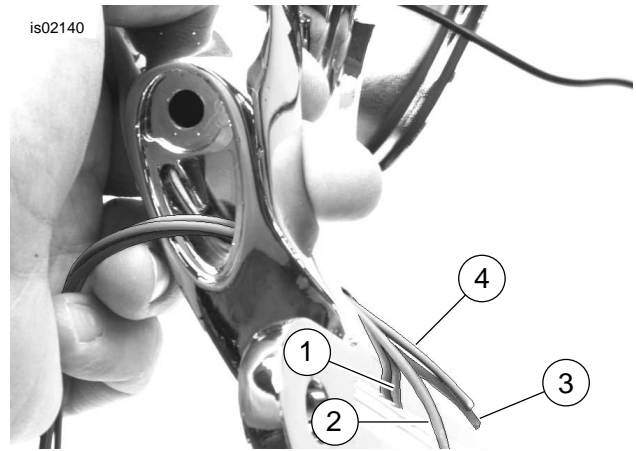

1. Grey wire (to auxiliary lamp)
2. Blue wire (to parking lamp)
3. Black wire (to ground)
4. Violet/Brown wire (to directional)

Figure 3. Directional Wiring Routing Shown

4. See Figure 1. From the kit, acquire directional stand off (2), hex socket screw (8), lock washer (7) and directional removed in step 4.
5. Install directional assembly (3) to stand off (2) by routing wires through directional stand off and passage in lamp bracket (1) along side grey wire from step 3. Secure directional assembly using lock washer (7) and hex socket head screw (8). Tighten to 96-120 **in-lbs** (10.8-13.6 Nm). Repeat for other side.

is02141



1. Wire sheathing
2. Wires
3. Lamp bracket passage (apply silicone)

Figure 4. Installing Wire Sheathing

6. See Figure 4. Install wire sheathing (1) onto wires (2). Insert a small amount of silicone into passage (3) of lamp bracket and firmly slide sheathing into passage and allow to dry before installing.
7. After silicone has dried, place a wire tie approximately 1 inch from the the siliconed area, clinch around sheathing to retain it in place.
8. Refer to appropriate Service manual and attach left and right turn signal connectors to turn signal wires.

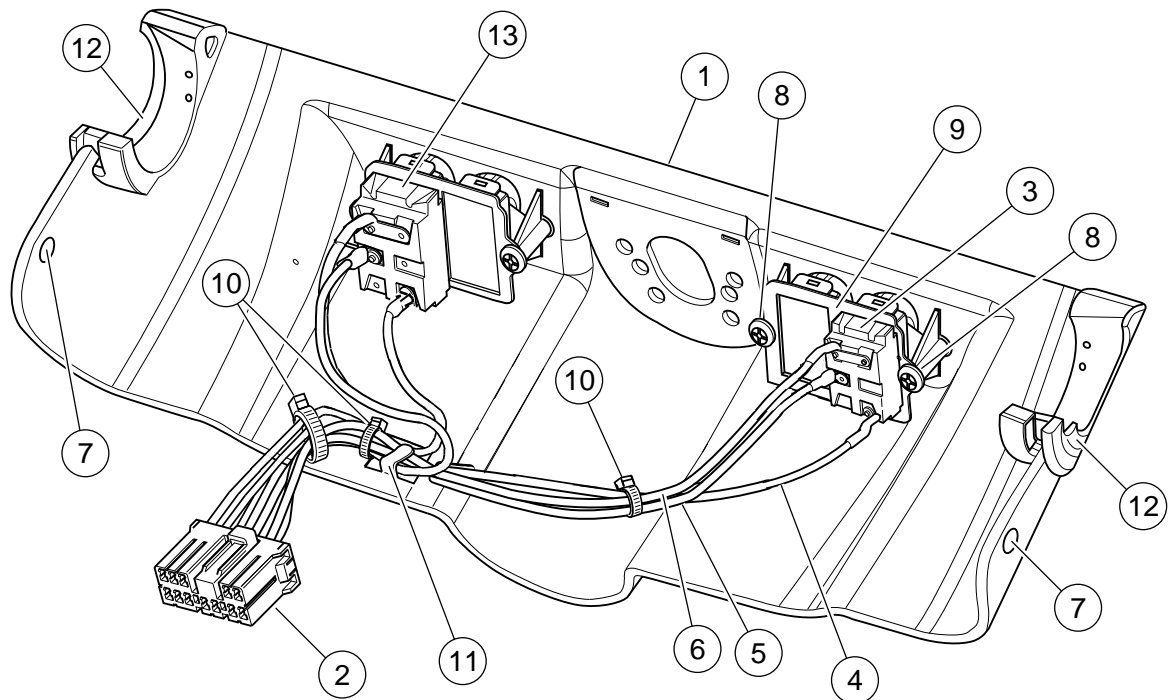

- |   |                              |
|---|------------------------------|
| 1. Fairing cap (inner)  | 8. Switch bracket screws (2) |
| 2. Fairing cap switch connector [105], 12-place Multilock (black) | 9. Switch bracket            |
| 3. Auxiliary light switch   | 10. Wire ties (3)            |
| 4. Wire, black (ground)   | 11. Flexible clamp           |
| 5. Wire, yellow   | 12. Rubber grommets (2)      |
| 6. Wire, gray   | 13. Accessory switch         |
| 7. Fairing cap fastener screw holes                               |                              |

Figure 5. Fairing Cap (Inner)

### Auxiliary Lamp Switch Assembly

1. Refer to the appropriate Service Manual and partially disassemble ignition switch.
2. See Figure 5. Remove two T27 **TORX**® screws (with flat washers) (7) to release fairing cap (1) from left and right sides of inner fairing.
3. With the front forks turned to the left fork stop, reach behind right side of fairing cap and disconnect the fairing cap switch connector [105], 12-place Multilock (black) (2) from the wiring harness.
4. Remove fairing cap from motorcycle. If wire ties are wrapped around the accessory switch wires, remove wire ties and discard.
5. Remove two T25 TORX screws (8) to release switch bracket (9) from fairing cap.
6. Place auxiliary light switch (3) into the fairing cap left side switch position with switch light towards rear of motorcycle. Route switch wires through switch bracket and position switch bracket over auxiliary switch. Press switch bracket onto switch.
7. Install two T25 TORX screws (8) to secure auxiliary switch (3) to fairing cap (1).

### Auxiliary Switch Connection

1. See Figure 5. With the fairing cap (inner) positioned close to the motorcycle, find the yellow (5), gray (6), and black (4) auxiliary switch wires.

#### NOTE

The fairing cap switch connector [105], 12-place Multilock (black) has numbers stamped into the secondary lock of the socket housing.

2. See Figure 6. Position the fairing cap switch connector [105], 12-place Multilock (black) (1) as shown. Find the auxiliary switch black (GRN) wire and insert pin terminal into position 8 (4). Find gray wire and insert pin terminal into position 7 (3). Find yellow wire and insert pin terminal into position 6 (2).

is02178

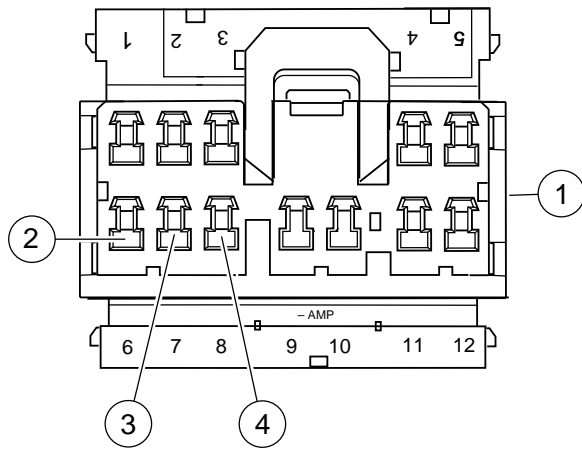

1. Fairing cap switch connector [105], 12-place Multilock (black)
2. Pin connection, position 6 (yellow)
3. Pin connection, position 7 (gray)
4. Pin connection, position 8 (black)

Figure 6. Fairing cap switch connections

3. See Figure 5. Bend up the flexible clamp (11) and place the auxiliary switch wires under flexible clamp and press clamp down onto wires. From the kit find three **new** wire ties (10) and secure accessory and auxiliary switch wires together as shown.
4. Check that rubber grommets (12) are installed on each side of fairing cap (1). Barbs on cap fit into holes in grommets.
5. Connect the fairing cap switch connector [105], 12-place Multilock (black) on the right side of fairing cap.
6. With the front forks turned to the left fork stop, install fairing cap over ignition switch housing. Check that grommets in fairing cap fully capture handlebar along with throttle and clutch cables.
7. Start two T27 TORX screws (with flat washers) to fasten fairing cap to left and right sides of inner fairing. Alternately tighten screws to 25-30 **in-lbs** (2.8-3.4 Nm).
8. Refer to the appropriate Service Manual and assemble ignition switch.
9. Install switch decal on switch.

## Lamp Bracket Installation

1. See Figure 7. Hold left side lamp bracket (1) in mounting position on motorcycle. Install two torx head screws (2) and washers (3) into lamp bracket assembly and attach lamp bracket to motorcycle. Tighten to 12-16 ft-lbs (16-22 Nm). Repeat for right side.

is02142

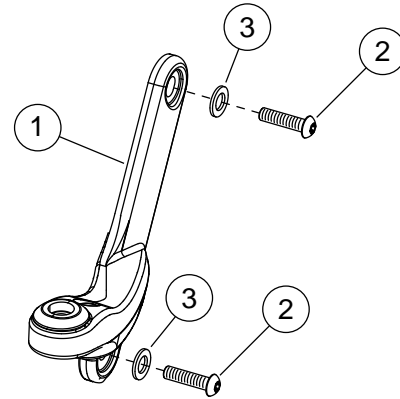

1. Lamp bracket
2. Torx head screw (1-1/4 inch)
3. Washer

Figure 7. Lamp Bracket Assembly (left side shown bare)

2. Route and connect left and right turn signal wires from lamp assembly to left and right harness connectors according to procedure in appropriate Service Manual.
3. Refer to the appropriate Service Manual and install outer fairing on motorcycle.

### NOTE

*Be sure to test ALL functions of kit before operating motorcycle to confirm proper operation. Refer to appropriate vehicle wiring schematic if in question.*

4. See Figure 1. Install lamp sealed beams and trim rings according to procedure in appropriate Service Manual using new nest rings (9).

## WARNING

**Connect positive (+) battery cable first. If positive (+) cable should contact ground with negative (-) cable connected, the resulting sparks can cause a battery explosion, which could result in death or serious injury. (00068a)**

5. Connect the battery cables, positive (+) cable first.
6. Check the correct operation of all lighting components and switches before operating vehicle.

## SERVICE PARTS

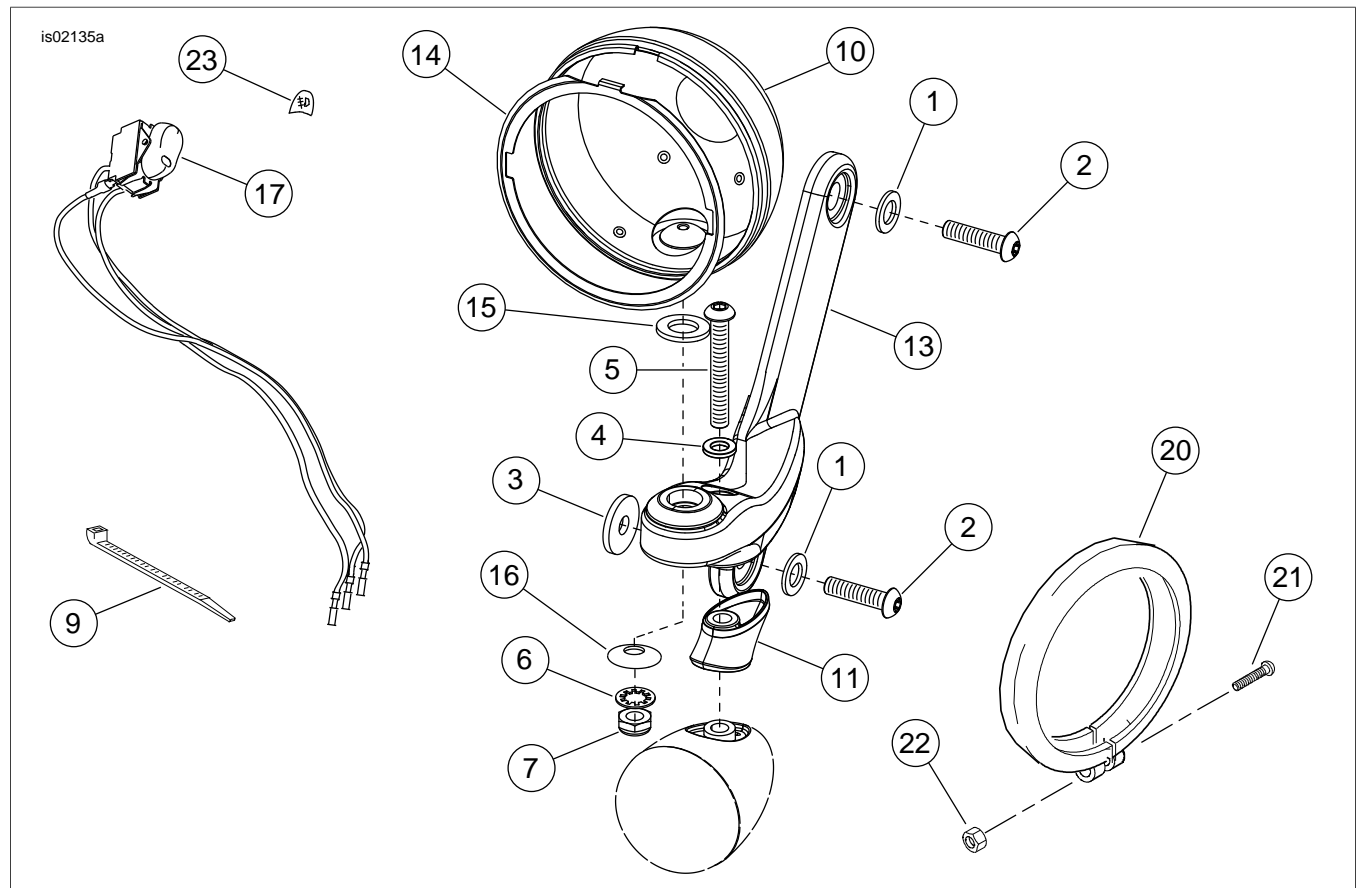

**Figure 8. Service Parts: Custom Auxiliary Forward Lighting Kit**

**Table 1. Service Parts Table**

Item	Description (Quantity)	Part Number	Item	Description (Quantity)	Part Number
1	Washer, flat (4)	57920-04	12	Bar, Passing lamp, RH (not shown)	68837-04A
2	Screw, Torx socket button head, 5/16-18 x 1.25 inch (4)	94602-98	13	Bar, Passing lamp, LH	68836-04A
3	Washer (2)	6645	14	Nest ring, pass/fog/pursuit lamps (2)	68331-02
4	Washer, lock 5/16 inch (2)	7041	15	Isolator, rubber (2)	40901-05
5	Screw, Torx socket button head, 5/16-18 (2)	4296	16	Clamp block, passing lamp (2)	69563-06
6	Washer, internal tooth lock, 3/8 inch (2)	7130W	17	Switch, spot lamp	71505-96
7	Nut, Nylon lock, 3/8-16 UNC (2)	7667	18	Terminal, socket #20-16AWG (10) (not shown)	73191-96
8	Extruded vinyl tubing, 0.38 inch dia. (2) (not shown)	70561-90	19	Housing, 4-way socket (2) (not shown)	73154-96BK
9	Cable tie, 0.91 x 7.82 inch (6)	10181	20	Bezel ring (2)	68725-62A
10	Housing, spot lamp, chrome (2)	68822-04		Bezel ring, black (2)	67700120
	Housing, spot lamp, black (2)	73340-10	21	Screw, bezel, #8-32 (2)	3514
11	Stand off, directional, chrome (2)	68821-00	22	Nut, bezel, #8-32 (2)	7606
	Stand off, directional, black (2)	73333-10	23	Decal, spotlight	15339-98