

PEQUEA

Tradition In Progress

All Manure Spreaders

OPERATOR'S MANUAL

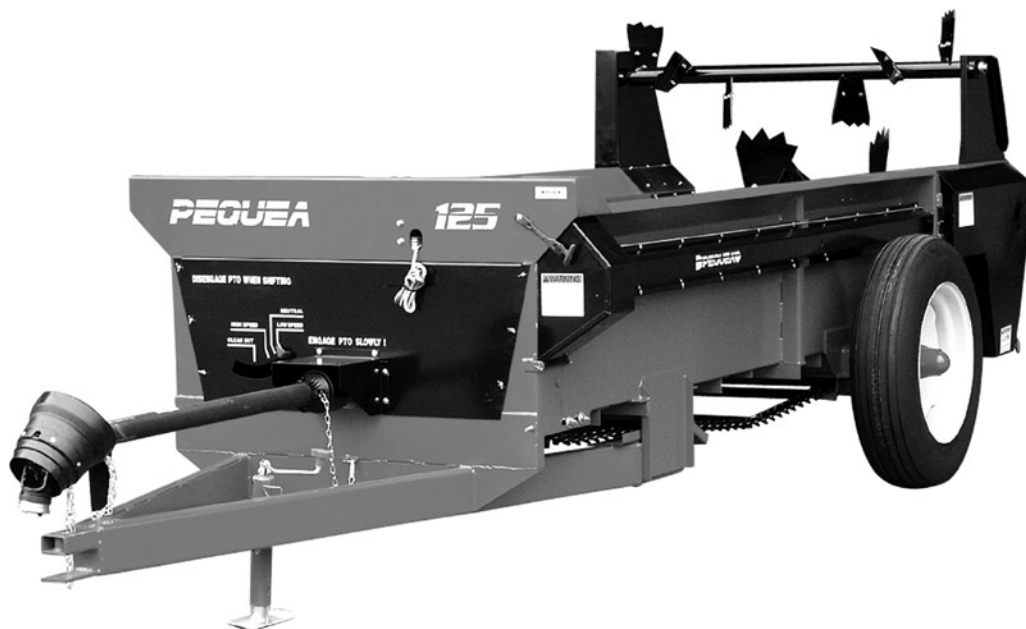

To The Owner

Contained in this manual is information that concerns the operation, adjustment and maintenance of the Pequea Manure Spreaders. Proper care and operation will assure you of a machine that will be as dependable as you expect it to be. For many years of long service and performance, please have all operators read this manual carefully and keep it available for ready reference.

These spreaders are intended to be towed by a vehicle or an agricultural tractor if powered by its PTO. These spreaders are designed to haul and spread all types of manure, including pen packed, with a moisture content below 85%.

The Pequea dealer from whom you purchased this spreader will instruct you in its general operation. Your dealer's staff of factory-trained service technicians will be glad to answer any questions that may arise regarding the operation of your spreader.

A complete line of Pequea Machine replacement parts is carried by your dealer. These parts have been inspected at Pequea and are manufactured with the same quality standards as has your spreader, in order to assure you of an accurate fit.

The serial number of this spreader is located on the left front corner of the spreader. When you are writing or calling for information or parts, please always refer to this number.



CAUTION: THIS SYMBOL IS USED THROUGHOUT THIS BOOK WHENEVER PERSONAL SAFETY IS INVOLVED. TAKE TIME TO READ AND FOLLOW THE INSTRUCTIONS. BE CAREFUL!

CAUTION: PICTURES IN THIS MANUAL MAY SHOW PROTECTIVE SHIELDING OPEN OR REMOVED TO BETTER ILLUSTRATE A SPECIFIC FEATURE OR AN ADJUSTMENT. REMEMBER TO CLOSE OR REPLACE ALL SHIELDING BEFORE OPERATING THE MACHINE.

Improvements and Changes

Because Pequea Machine continually strives to improve all of our products, we reserve the right to make changes and improvements wherever it is practical, without obligation to make those same changes or improvements to the equipment sold previously.

Contents

SPECIFICATIONS	2
DECALS	3
SAFETY/ CAUTION	4
BEFORE USE	5
OPERATION	6
LOADING	9
FEED CONTROL POSITIONS	10
LUBRICATION	14
MAINTENANCE	19
INDEX	23
MAINTENANCE RECORD	24
DELIVERY REPORT	25
WARRANTY	26
TROUBLESHOOTING	27

For illustrated parts breakdown and parts lists please visit www.pequeamachine.com

Specifications

Models	25 GD	50 GD	50 PTO	80 PTO	125 PTO	175 PTO
Capacity	25 Bu. 18 Cu. Ft.	50 Bu. 36 Cu. Ft.	50 Bu. 36 Cu. Ft.	80 Bu. 57 Cu. Ft.	125 Bu. 90 Cu. Ft.	175 Bu.
Overall Length	9'6"	12'6"	12'6"	14'4"	16'6"	17'8"
Overall Width	44"	54"	54"	60-1/2"	76"	86"
Loading Height	30"	35"	35"	39"	45"	44"
Flared Width	34"	43"	43"	47-1/2"	56"	66"
Box Width	28"	36"	36"	40"	47"	54"
Box Length	66"	84"	84"	104"	128"	140"
Box Height	16"	18"	18"	20"	23"	24 1/2"
Box Construction	Fully welded, 12 Gauge Steel				Fully welded, Cor-ten 11 Ga.	Fully welded, Cor-ten 10 Ga.
Floor Construction	High density Poly vinyl 3/4" T & G					
Beater Paddles	8 Replaceable					10 Replaceable
Beater Diameter	18"	21"	21"	21"	26"	26"
Drive	2 Wheel Ground Drive		PTO w/ 1 speed gearbox		PTO w/ 2 speed gearbox	
Apron Chain	5/16 T-Rod	7/16 T-Rod				
Spindle	1 5/8"	1 5/8"	1 5/8"	1 3/4"	2 1/8"	
Wheels/Tires	12 x 6-4 Bolt 6-12 Traction	15 x 5-4 Bolt 5.90-15 Traction	15 x 5-4 Bolt 6.40-15 Imp.	15 x 6-6 Bolt 9.50-15 Imp.	20 x 7-8 Bolt 7.50-20 Imp.	20 x 7-8 Bolt 8.25-20 Off-road
Jack	2K Bulldog					
Weight w/ tires	425 lbs.	950 lbs.	950 lbs.	1125 lbs.	1850 lbs.	2220 lbs.
Tongue Weight Empty	35 lbs.	60 lbs.	60 lbs.	80 lbs.	110 lbs.	180 lbs.
Tongue Weight (Loaded Estimated)	50 lbs.	95 lbs.	95 lbs.	125 lbs.	175 lbs.	330 lbs.
Horsepower Required	N/A	N/A	15 HP @ PTO	18 HP @ PTO	30 HP @ PTO	65 HP @ PTO
OPTIONS						
Fine Spread Pan	YES	YES	YES	YES	YES	YES
Top Beater	N/A	N/A	N/A	YES	YES	YES
End Gate	N/A	N/A	N/A	N/A	YES	YES

Pequea Machine, Inc. reserves the right to change specifications without notice.

Safety Decals

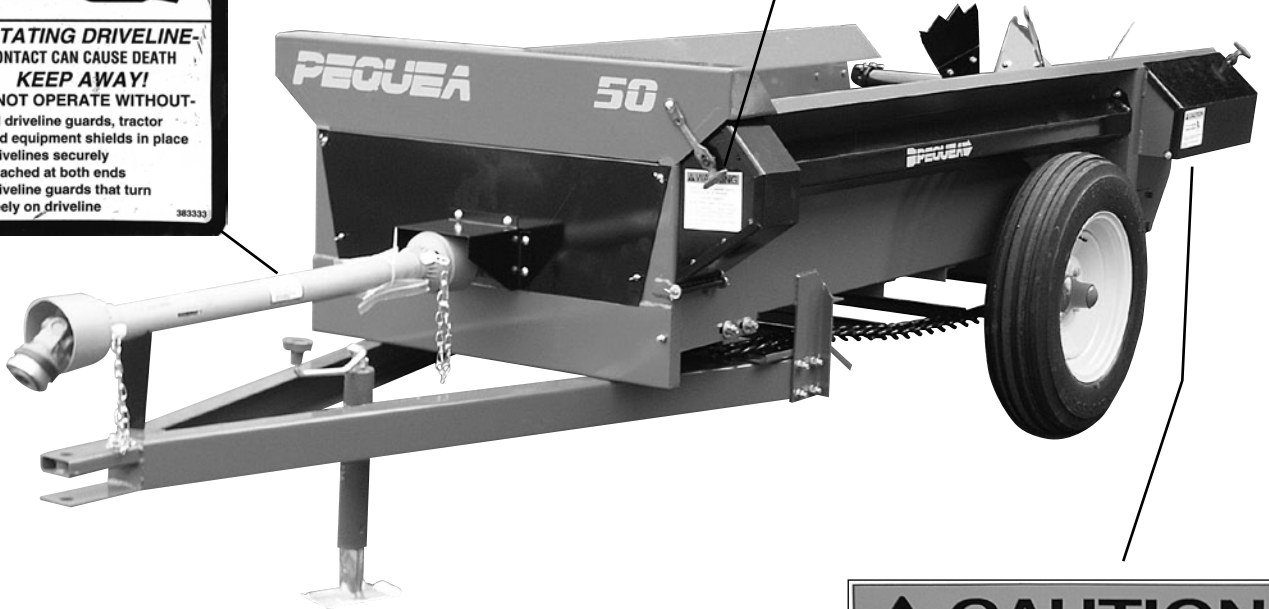
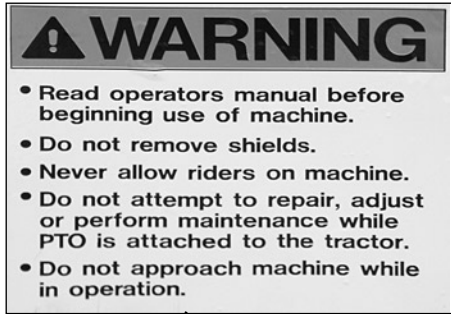

On both sides of rear of spreader

Caution



MOST FARM IMPLEMENT ACCIDENTS CAN BE AVOIDED BY THE OBSERVANCE OF A FEW SIMPLE SAFETY PRECAUTIONS.

1. DO NOT CLEAN, LUBRICATE OR MAKE ANY ADJUSTMENTS ON THE SPREADER WHILE IT IS IN MOTION.
2. DO NOT START THE SPREADER UNTIL YOU KNOW EVERYONE IS CLEAR OF THE MACHINE AND HAVE MADE SURE NO TOOLS ARE LYING ON THE MACHINE.
3. DO NOT WORK AROUND THE UNIT IN LOOSE CLOTHING THAT MIGHT CATCH IN ANY OF THE MOVING PARTS.
4. DO NOT ATTEMPT TO PULL MATERIAL FROM ANY PART OF THE SPREADER WHILE IT IS IN OPERATION.
5. DO NOT GET OFF THE TRACTOR WHILE TRACTOR PTO IS ENGAGED.
6. REPLACE ALL SHIELDS AFTER LUBRICATION OR REPAIRS.
7. DO NOT ALLOW ANYONE TO RIDE ON SPREADER.
8. PARK ON LEVEL GROUND OR BLOCK WHEELS TO PREVENT SPREADER FROM ROLLING.

Before Using The New Machine

1. Check for proper assembly and adjustment and make sure all bolts are tightened securely.
RETIGHTEN THE BOLTS AFTER A FEW HOURS OF OPERATION.
2. Torque the wheel bolts to 120 ft. lbs. Recheck the bolts after every other load until the torque does not decrease and every 300 loads thereafter.
3. Check the tires and inflate them to the recommended pressure. The tire ratings are printed on the sidewall of the tire.
4. Adjust the tractor hitch and attach the spreader to the tractor as detailed in the following sections.
5. Lubricate the machine completely and check the oil level of the gearboxes.
6. Operate the machine slowly for a period of time to run the chains in and determine that all parts work freely.
7. Equip the spreader with an SMV (Slow Moving Vehicle) emblem (available from your dealer) if it will be transported on public roadways.
8. Do not operate the spreader until the safety precautions in this manual and on decals on the spreader have been read and understood by the operator.

Operation

GENERAL INFORMATION

On Pequea Machine, Inc. equipment, left and right are determined by standing behind the unit, looking in the direction of travel.



CAUTION: NEVER USE TOO SMALL A VEHICLE. A SMALL VEHICLE MAY BE ABLE TO PULL THE UNIT, BUT THE TRACTOR WOULD NOT BE HEAVY ENOUGH FOR ADEQUATE TRACTION AND BRAKING TO CONTROL THE WEIGHT OF THE HEAVY SPREADER ON HILLS AND FOR STEERING.

A good rule is to use a tractor that is heavier than the spreader and load combined.

TRACTOR HITCH

The hitch of the spreader is designed for a standardized tractor hitch. Adjust the tractor drawbar so it is 12"-14" above the ground. Secure the drawbar so the hitch pin hole is directly below the power drive line.

Operation Cont.

Pequea 25G & 50G Ground Drive



Figure 7-1 (model 25G only)
1- Apron control arm
2- Beater control arm



Figure 7-2 (model 25G only)

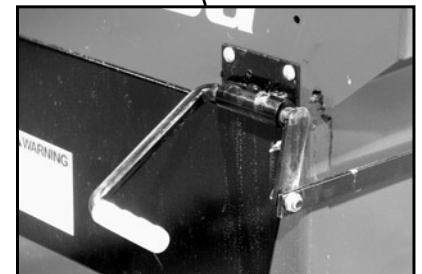
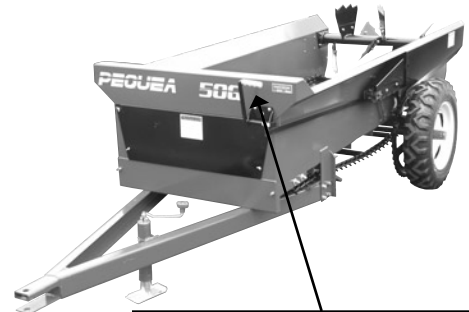

Pull handle down to engage the beaters and web (model 50G only).



IMPORTANT: Shut down the tow vehicle before getting off to engage beaters and apron.

Engage the beaters and apron by lowering the control arms until locked in the horizontal position (see figure 7-1,7-2).

You are now ready to spread manure.

The rate of application can be further controlled by selecting the appropriate gear of the vehicle to regulate ground speed. Note that an almost unlimited choice of spreading rates is made possible by various combinations of ground speed and apron speed.

IMPORTANT: It is advisable to load the spreader only with material it is designed to spread. Overloading the spreader or foreign objects in the manure may jam or plug the spreader. Should this occur, take the following steps to clean the spreader, **OBSERVING THE SAFETY PRECAUTIONS IN THIS MANUAL.**

1. Only one person should attempt to unplug a machine.
2. Disengage.
3. Stop the vehicle engine.
4. Remove material from the area of the beaters.
5. Engage.
6. Start the vehicle engine.

PLEASE NOTE: When the load is very low, manure will be thrown forward by the beaters. Slowing down the ground speed, or simply disengaging the beaters by pulling the handle up will stop the manure from being thrown forward.

Operation Cont.

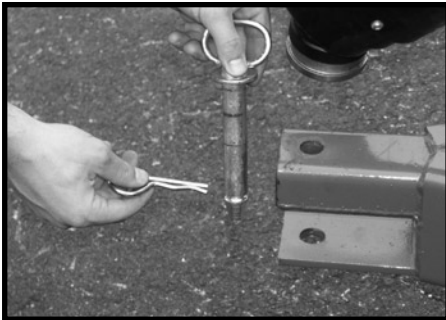

Figure 8-1



Figure 8-2



Figure 8-3 Safety Chain

ATTACHING TO THE TRACTOR

1. Fasten the spreader hitch to the drawbar with a 3/4" diameter hitch pin that cannot bounce out, Figure 8-1.



CAUTION: DAMAGE TO THE SPREADER OR OTHER VEHICLE, AS WELL AS INJURY TO THE OPERATOR, MAY OCCUR IF A CORRECT PIN IS NOT USED.

2. Remove the weight from the jack. Swing the jack into a horizontal position and lock it to provide maximum ground clearance.
3. Pull back on the collar and slide the PTO onto the tractor shaft until the balls engage in the groove in the tractor shaft. Release the collar, Figure 8-2. Check to make sure that the PTO is locked on the shaft. To remove the PTO, pull back on the collar to unlock the balls and slide the PTO off the tractor shaft.

NOTE: The balls and yoke hub where the collar slides must be free of paint and /or rust and must be kept lubricated with oil for proper operation.



ALWAYS ATTACH PTO SAFETY CHAIN TO TRACTOR BEFORE OPERATING. SEE FIGURE 8-3.

4. Before unhooking the spreader, make sure the PTO is disconnected.

ATTACHING TO THE VEHICLE (25G)

1. Fasten the spreader hitch to the drawbar with a 3/4" diameter hitch pin that cannot bounce out, (Figure 8-4).



CAUTION: DAMAGE TO THE SPREADER OR OTHER VEHICLE, AS WELL AS INJURY TO THE OPERATOR, MAY OCCUR IF A CORRECT PIN IS NOT USED.

2. Remove the weight from the jack. Swing the jack into a horizontal position and lock it to provide maximum clearance (Figure 8-4, 8-5).



Figure 8-4



Figure 8-5



CAUTION: PARK ON LEVEL GROUND AND BLOCK THE WHEELS TO PREVENT THE SPREADER FROM ROLLING.

Loading

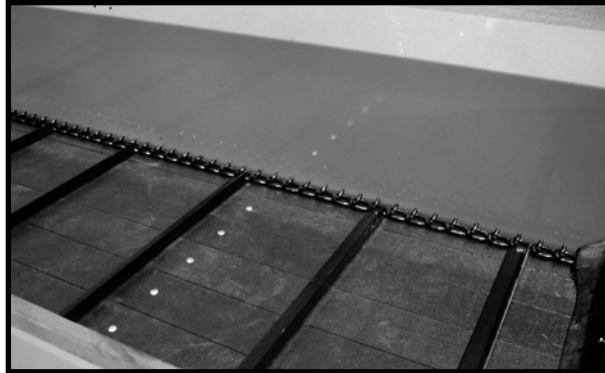

Figure 9-1

In freezing weather, make certain the apron chain is not frozen to the spreader floor or web slides, Figure 9-1, 9-2. Make sure there are no lumps of manure frozen to the floor.

IMPORTANT: In freezing weather, coating the sides of the spreader with diesel fuel makes it easier to clean off. Using diesel fuel on all sliding and pivoting points helps keep them free and working properly.

Begin loading the spreader at the front end and work toward the rear until loading is completed. Loading this way permits the material to be spread uniformly and reduces the draft load.

Loading from front to rear is particularly important when the spreader is loaded by a mechanical loader because this type of load requires more power to spread than other loads, especially in long straw manure. Avoid excessively large scoops of straw manure when using a mechanical loader.

If the material has high soil content, wet the box with water or used crankcase oil to prevent unnecessary problems from excessive apron loads. Never allow the curb weight to exceed the tire rating in pounds.

For best spreading, level the load about 12" – 14" above the top of the beater. Never dump material onto the beater. Excessively high, heavy loads of mechanically loaded pen manure will decrease spreader life and prevent a uniform spread pattern.



Figure 9-2

Before Loading

- Check springs to ensure proper pressure is being placed by the dog onto the ratchet wheel (Figure 10-1).
- Be sure to grease all moving parts (refer to lube section).
- Check bushings in crank-arm for excessive clearance, replace if needed.
- Oil the chain and remove any standing manure or debris.

The rate of application can be further controlled by selecting the appropriate gear of the tractor to regulate ground speed. Note that an almost unlimited choice of spreading rates is made possible by various combinations of ground speed and apron speed.

IMPORTANT: It is advisable to load the spreader only with material it is designed to spread. Overloading the spreader or foreign objects in the manure may jam or plug the spreader. Should this occur, take the following steps to clean the spreader, **OBSERVING THE SAFETY PRECAUTIONS IN THIS MANUAL.**

1. Disengage the PTO
2. Stop the tractor engine.
3. Remove material from the area of the beaters.
4. Start the tractor engine.
5. Engage the PTO slowly.
6. Only one person should attempt to unplug a machine.

Feed Control Positions

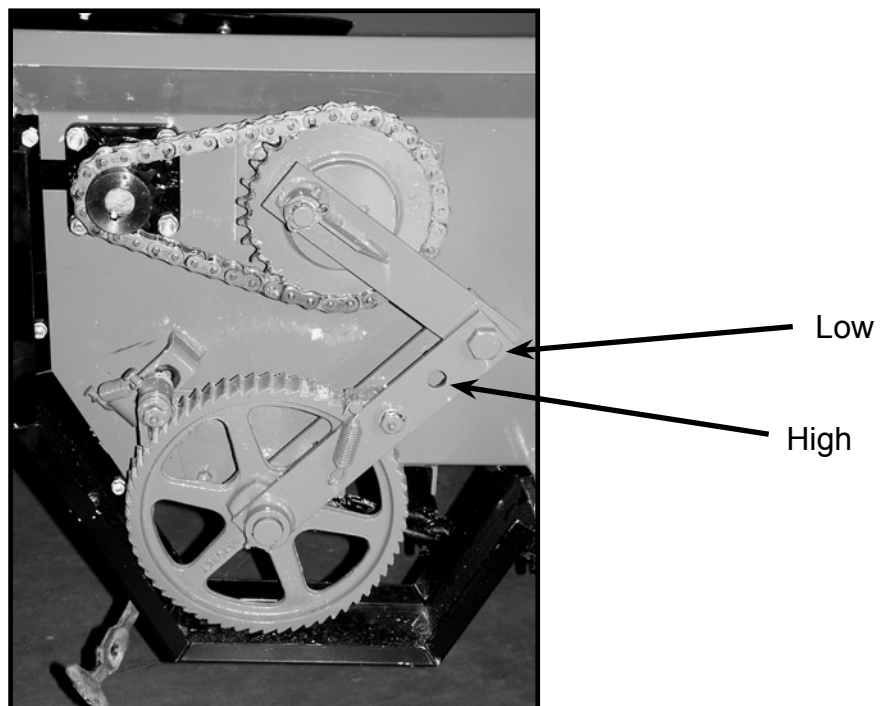

Figure 10-1 (50G, 50P, 80P)

Feed Control Positions



Figure 11-1

125 & 175 Feed Control

The four speed control positions are shown in Figure 11-1

L – Low speed: The apron is moving slowly for normal application of manure, the beater is engaged.

N – Neutral: Apron is disengaged. Beater is engaged.

H – High speed: The apron moves at higher rate of speed for a heavy application of manure, the beater is engaged.

Clean-Out: The beater is stopped. The apron continues to operate at a faster speed to clean the floor of manure.

The apron speed control lever is activated by pulling the control rope.

IMPORTANT: The PTO must be stopped when shifting from “Clean-Out” to any operating gear.

Mechanical Drive Machines

The apron is started by pulling the rope to advance the selector to the “L” position, or slow speed. In the slow position, a light application of manure is applied.

When the spreader is almost empty, the bed can be cleaned thoroughly by pulling the control rope and shifting the selector to the “Clean-Out” position. With the selector in this position, the beaters will stop and the apron will continue to operate, saving unnecessary driving. A heavier application can be applied by positioning the speed selector to “H”, fast.

IMPORTANT: Always stop the PTO before moving the feed control lever from the “Clean-Out” position to avoid damaging the gearbox.

NOTE: Depending on the position of the clutches when the PTO is stopped, a second pull of the rope may be required to turn the selector to “Clean-Out”.

If the spreader is equipped with a hydraulic end-gate, lower the hydraulic end-gate and be sure the pan is closed to prevent damage while traveling back to the barn at fast ground speeds.

Feed Control Positions Cont. (125 & 175 PTO)

ATTENTION: Operating at over-speed will shorten the life of the spreader.

The rate of application can be further controlled by selecting the appropriate gear of the tractor to regulate ground speed. Note that an almost unlimited choice of spreading rates is made possible by various combinations of ground speed and apron speed.

IMPORTANT: It is advisable to load the spreader only with material it is designed to spread. Overloading the spreader or foreign objects in the manure may jam or plug the spreader. Should this occur, take the following steps to clean the spreader, OBSERVING THE SAFETY PRECAUTIONS IN THIS MANUAL.

1. Disengage the PTO
2. Stop the tractor engine.
3. Remove material from the area of the beaters.
4. Position apron feed control in neutral.
5. Start the tractor engine.
6. Engage the PTO slowly.
7. Only one person should attempt to unplug a machine.

Hydraulic End-gate

IMPORTANT: If using a hydraulic end-gate while hauling dry or pen packed manure, raise the end-gate completely before starting the apron.

If hauling slurry manure (which flows readily), start the beater, then raise the hydraulic end-gate slowly to regulate the flow of manure. Once the slurry manure has reached its level, depending on flow ability, the end-gate can be raised completely. Slurry manure is animal waste with little or no bedding or water-absorbing materials added. It will usually seek its own level within any given confinement. For best results, the operator should run the tractor at the rated PTO speed of 540 RPM and regulate ground speed at no more than 7 MPH. Do not operate the spreader with a PTO speed greater than the standard rating of 540 RPM.

Feed Control Positions Cont.

Unloading

Relatively dry loads as a rule unload in an even distribution with very little material being thrown forward. The exception to this is when the load is almost completely spread. While there is actually less than a yard of material left, clearing the bed can be a nuisance with some of the matter being thrown forward onto the operator. The load itself or a hydraulic gate usually blocks matter from being thrown forward but in the case of no gate and a significantly reduced pile the action of the beater can result in some manure being thrown forward. Several techniques have proven to be successful in minimizing this problem and are outlined here.

- If you haven't finished spreading, simply refill the spreader which will block the material from flying forward.
- Reduce the speed of the PTO to shorten the pattern of the spread and keep it from reaching the front.
- (For 125 & 175 only) Follow the instruction in this manual for the "Clean Out " mode which allows all of the matter to be removed without the beater working.



CAUTION: SOME PICTURES IN THIS MANUAL SHOW SAFETY SHIELDS REMOVED OR OPEN TO SHOW PARTS BEING SERVICED OR FOR CLARITY. ALL SHIELDS SHOULD BE CLOSED OR REPLACED PRIOR TO OPERATING THIS MACHINE.

Transporting

NOTE: Transporting the machine with the rear section of the PTO assembly dangling from the jack shaft may damage this part. The shield will be dented as a result of bouncing against the hitch, by the drawbar or bumper when left dangling, and dirt and grit from the road will accumulate on the critical internal sliding surfaces. Remove the complete PTO assembly when towing the spreader with a truck, or attach the PTO to both spreader and tractor.

Storage

If, after being used, the spreader is not to be operated for some length of time, take the following steps to insure long life and trouble free start-up for the next usage period.

1. Remove the manure from the inside and outside of the spreader.
2. Coat the chains, including the apron chain, with used oil.
3. If at all possible, store the spreader indoors and remove weight from the tires.

Lubrication

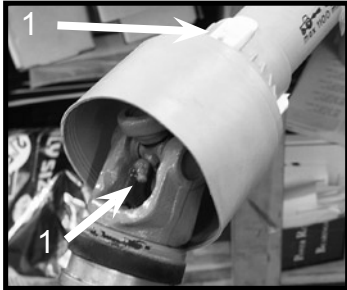

Figure 14-1 FRONT

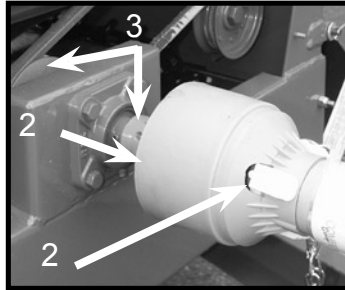

Figure 14-2 REAR

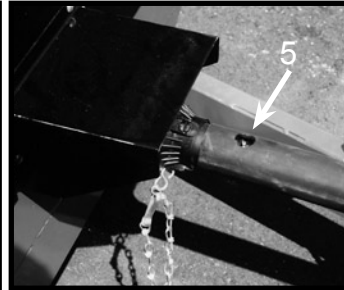

Figure 14-3

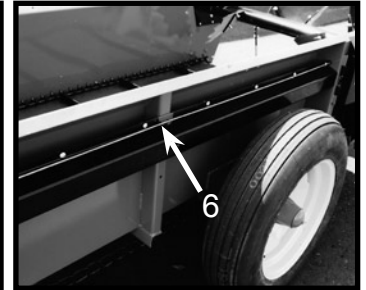

Figure 14-4



CAUTION: ALWAYS STOP THE MACHINE TO LUBRICATE OR TO MAKE ANY ADJUSTMENTS.

All spreader models are designed to require a minimum of lubrication. However, the importance of sufficient and proper lubrication cannot be over-emphasized as it is the best insurance against unnecessary repairs and greatly increases the life of the machine.

The operator should become familiar with all lubrication points and establish a systematic routine to insure complete and quick lubrication of the machine. Refer to the following pages for location of grease fittings.

The following system of lubrication is suggested:

Lubricate the entire machine thoroughly with a good grade of gun grease every 100 loads or once a month, whichever comes first. Make certain the grease fittings are free of paint and dirt and force grease into them until the grease comes out around the shaft. **Caution: Do not over lubricate sealed bearings.** Following a regular maintenance schedule (record on page 35); 1 stroke of a manual grease pump into a U joint Zerk fitting and 2 strokes on any other sealed bearing should be sufficient.

The following greases are recommended for use rather than other EP-2 lubricants, because they are less prone to washing out under exposure to rain and other fluids.

Texaco Marfak Multipurpose #2
Gulfcrown #2 (Gulflex A)
Shell Alvania EP-2

Shell Super Duty
Exxon Ronex MP
Lubriplate 1200-2

1. PTO universal joint – front, Two (2) Figure 14-1 *, See arrows.
2. PTO universal joint – rear, Two (2) Figure 14-2 *, See arrows.

NOTE: Use care when greasing universal joints, as seals may be damaged.

3. , 4. Input shaft bearings (inside & outside bearings), 14-2
5. PTO shaft grease - 14-3
6. Drive shaft bearing- One (1), Figure 14-4 *

* These are sealed bearings.

Lubrication Cont.



Figure 15-1

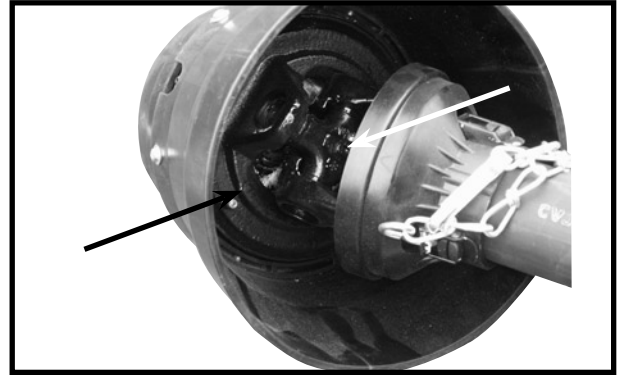

Figure 15-2

Model 125 & 175 PTO Shaft Only

1. PTO universal joint – front, Four (4) Figures 15-1,15-2 *

NOTE: Use care when greasing universal joints, as seals may be damaged if overgreased.

* These are sealed bearings.

Lubrication Cont.

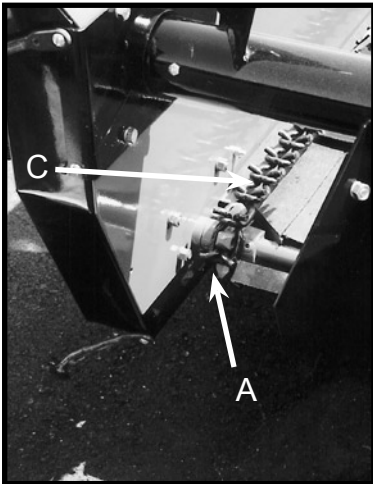

Figure 16-1

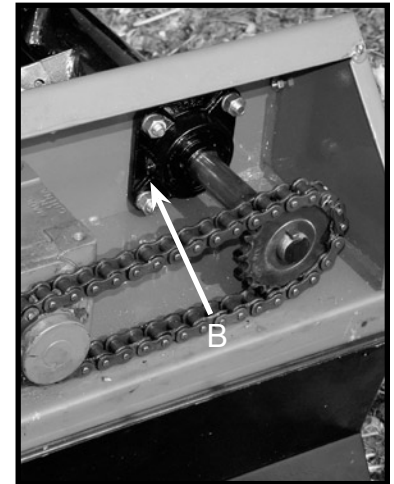

Figure 16-2

- A. Apron shaft bearings - Two (2) Figure 16-1
- B. Beater bearings - Figure 16-2, 16-5, 17-1*
- C. Lubricate the apron chain with SAE #30 oil or similar lubricant at least twice yearly, more often if the manure is of high acid nature or if the machine is stored outside. Regular lubrication of the apron chain will substantially increase its life - Figure 16-1
- D. Drive shaft (125 & 175 only), Figure 16-3

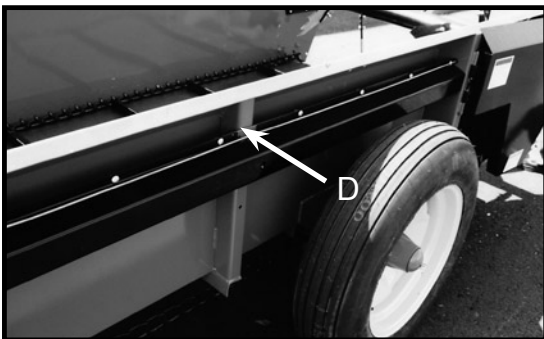

Figure 16-3



Figure 16-4

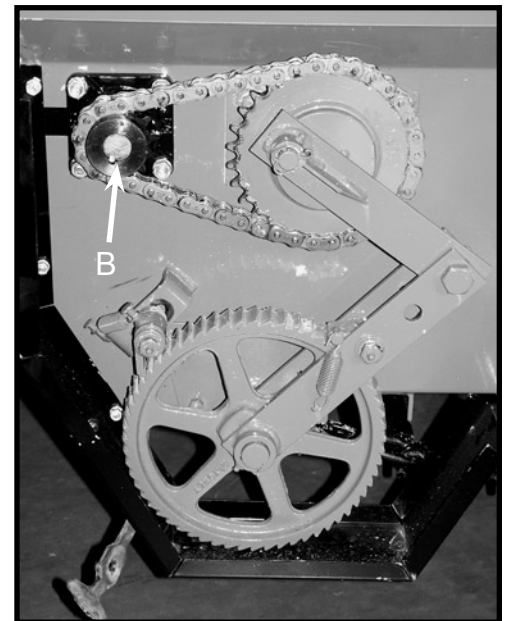

Figure 16-5

* These are sealed bearings.

Lubrication Cont.

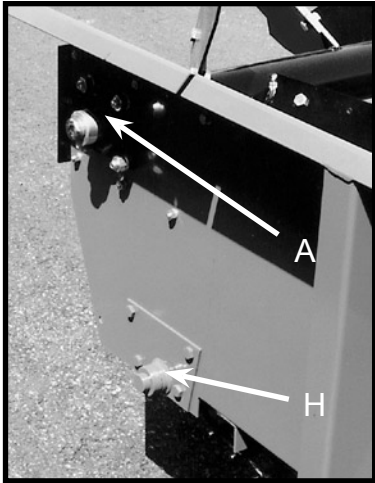

Figure 17-1

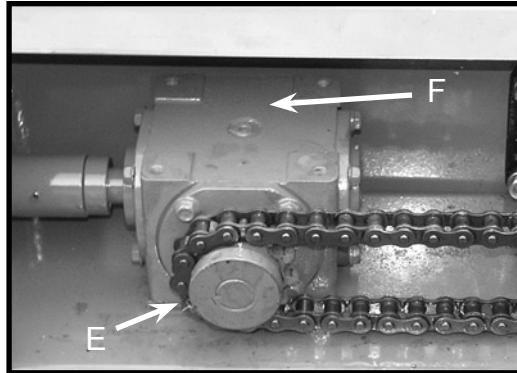

Figure 17-2

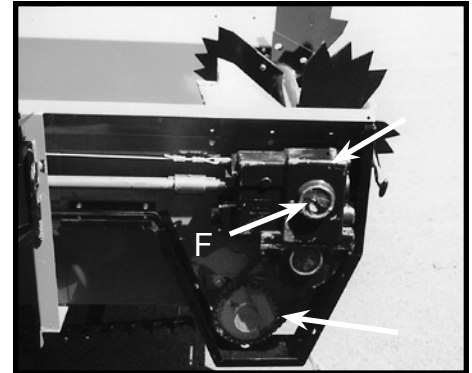

Figure 17-3

- E. Lubricate drive chains with engine oil every 100 loads or once a month- One (1) Figure 17-2.
- F. Change oil once a year, fill to the check plug with SAE 80-90 gear oil. If no check plug, fill until gears are coated with lubricant. Figure 17-2, 17-3
- G. Lubricate wheel hubs every 100 loads. Figures 17-4, 17-5
- H. Apron shaft bearings (125 & 175 only). Figure 17-1

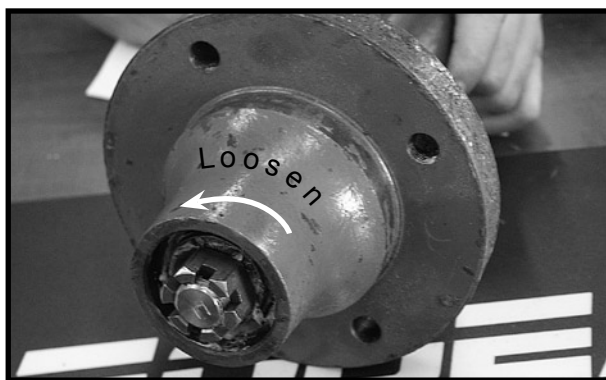

Figure 17-4

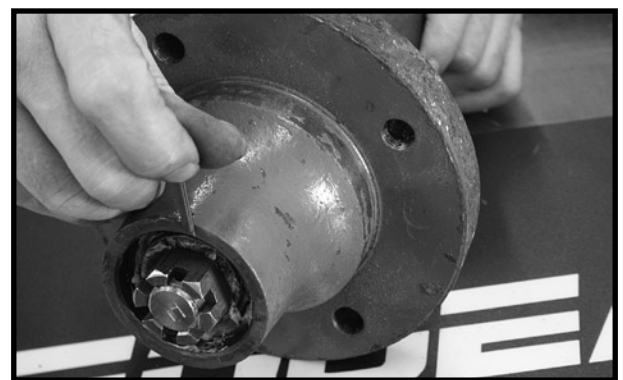

Figure 17-5

Remove cotter key and turn hub nut counter clockwise. Apply slight pressure on top face of tire to loosen bearing. Remove bearing, clean and pack with new, clean grease. Replace bearing, and tighten nut fully. Do not over tighten

Attempt to spin tire. If it is sluggish, turn nut counter clockwise at least 1/6 turn but no more than 1/3 turn. Replace cotter key and bend ends. Replace hub cap.

Lubrication Cont.

Pequea 50G Ground Drive

Coat chain with used oil or any other chain lubricant.



Grease

Grease

Pequea 50G shown

Grease

Maintenance



CAUTION: DO NOT ATTEMPT TO CLEAN OR ADJUST THE MACHINE WHILE IT IS RUNNING.

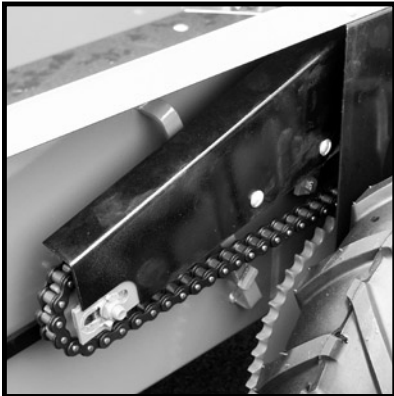

Figure 19-1

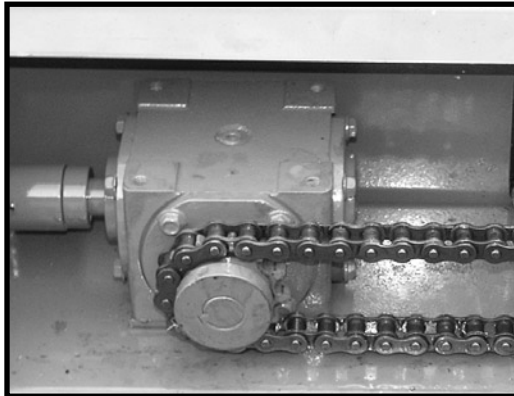

Figure 19-2

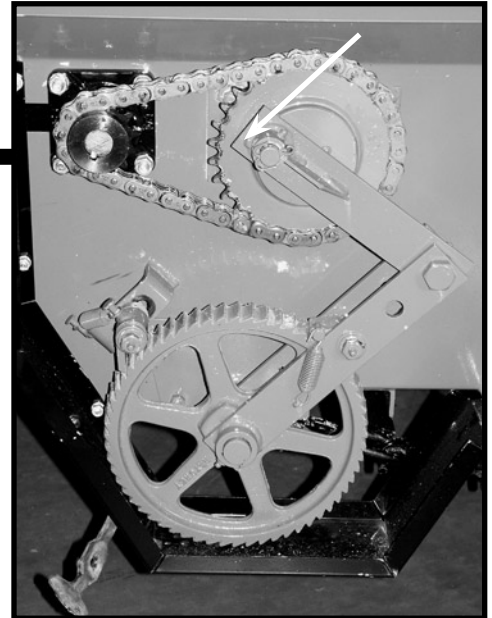

Figure 19-3

Gearbox Drive Chains

When the gearbox drive chains are properly tensioned, they should deflect 1/2" from a straight line mid-way between the sprockets.

For all models except the 125 & 175 PTO, the chains are tightened by loosening the Reduction Bracket Bolts (Located behind the large drive sprocket, see Figure 19-3) and sliding the sprocket towards the front of the spreader. If the bracket runs out of adjustment and the chain is not tightened properly, remove a link to create more adjustment. For 125 & 175 PTO models, the chains are tightened with the chain tighteners, (A), Figure 19-4)

Apron Drive Shear Bolt (125P & 175P only)

The apron drive is protected by a shear bolt, (B), Figure 19-4. Shearing of the bolt is usually due to the apron being frozen to the floor, or the slats catching on manure frozen to the floor.

An extra shear bolt is carried in the shield shown at (C), Figure 19-5.

In some cases, the bolts will shear due to the spreader being overloaded. If the bolt shears, the drive hub can be rotated counter clockwise until the bolt holes align. Always determine the cause of the failure, and eliminate it before installing the new bolt. Bolt can be replaced with a 5/16 x 3/4 Grade 5.

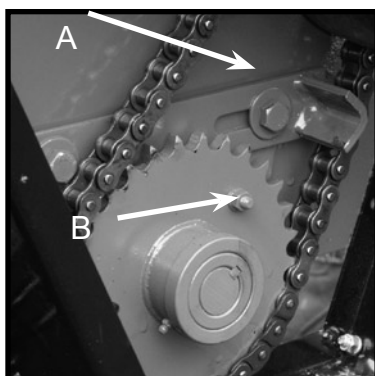

Figure 19-4

Maintenance Cont.

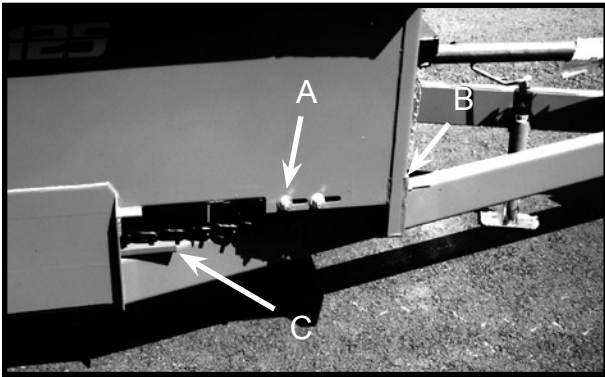

Figure 20-1

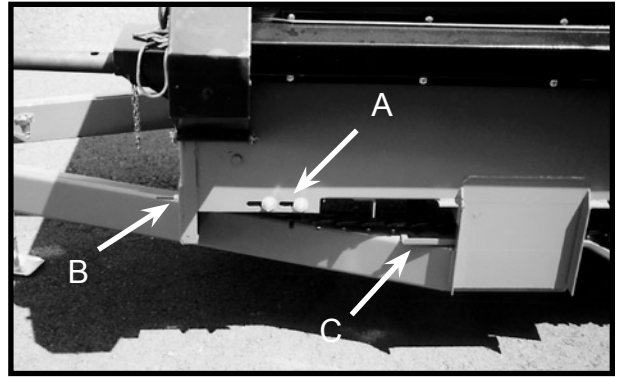

Figure 20-2

Apron

Periodically inspect the apron for bent or damaged slats. Always straighten or replace any bent or damaged slats immediately.

NOTE: Tighten the adjusting bolts equally on each side so the apron slats run parallel with the apron drive shaft. The apron can be damaged if the machine is operated with one end of the apron slats running ahead of the opposite end. Do not tighten the apron chains excessively.

Adjust the apron by loosening the idler mounting bolts at (A), Figure (20-1, 20-2), on both sides. Tighten the adjusting bolts at (B) Figure (20-1, 20-2) In this adjustment the chain should rest slightly on the web slide and should sag noticeably. (C) Figure (20-1, 20-2). After the apron chain is properly adjusted tighten the idler mounting bolts (A) Figure (20-1, 20-2).

The T-rod chain can be shortened when necessary by removing the chain tension, turning the chain at an angle, and removing the link.

Drive Belt

Note: the belt tension should be checked and adjusted after the first 10 to 15 loads, due to the effect of initial belt stretch and wearing of paint from the sheave grooves. Thereafter, it should be checked every 300 loads.

IMPORTANT: Tightening the belt excessively may result in damage to the spreader and may cause premature belt failure.

To accurately check and adjust the belt tension, remove the belt shield.

The belt tension is adjusted by loosening the nut that holds the idler pulley (A) Figure 20-3, slide the idler pulley (B) in the direction that tightens the belt until there is about 1" of deflection on a straight line midway between the drive sheaves.

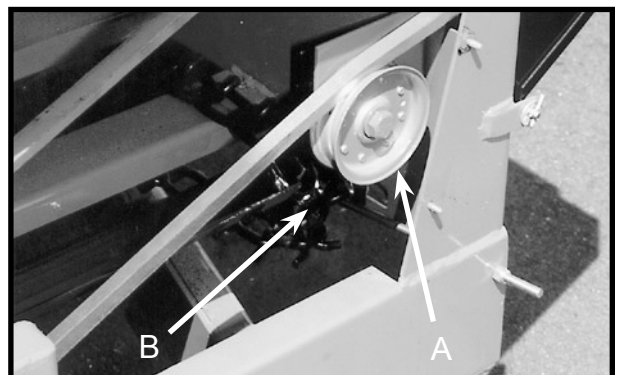

Figure 20-3

Maintenance Cont.

Feed Control (125 & 175 PTO)

Check the feed control system at the beginning of each season and adjust, if necessary, to compensate for wear. Be sure the control linkage always works freely.

1. Set the speed selector to L (A), Figure 21-1.
2. Locate the adjustment bracket (B) attached to the gearbox shifter, Figure 21-2.
3. Adjust the cable until there is approximately $1 \frac{1}{16}$ " space between the gearbox housing and the retaining ring on the shifter Figure 21-2.



Figure 21-1

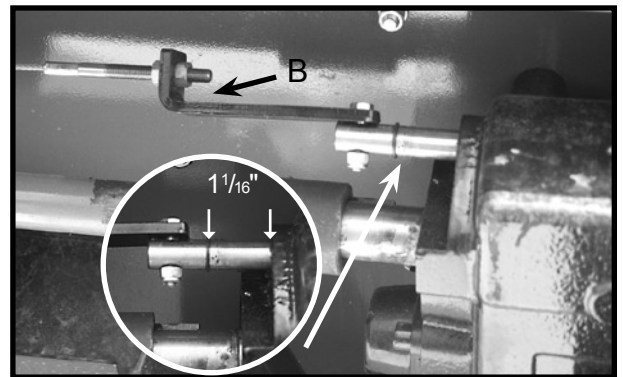

Figure 21-2

Wheel Bearings

Adjust wheel hub bearings after 100 loads and once each season thereafter.

Jack up the spreader to remove the weight from the wheel(s). Remove hub cap and cotter pin. Torque wheel hub bearings nut to 35 ft. lbs. while rotating the hub. Back off (loosen) the nut, Figure 21-3, one flat plus enough to install the cotter pin, Figure 21-4, $1/6$ turn minimum, $1/3$ turn maximum.



Figure 21-3



Figure 21-4

Maintenance Cont.

General

Check to be sure all safety shielding is free turning.

Remove manure buildup regularly.

Protect the machine from the weather when it is not in use.

At the close of the season, check the machine carefully and replace all worn or damaged parts.
USE GENUINE PEQUEA MACHINE, INC. SERVICE PARTS SUPPLIED BY YOUR AUTHORIZED
PEQUEA MACHINE, INC. DEALER.

Keep beater paddles and teeth clean. Remove all materials, such as twine and wire, that wrap on the beaters.

PTO Assembly

As pointed out in the “Lubrication” section, care must be taken to keep the driving elements well lubricated and free sliding. Failure to observe this precaution will result in excessive force being required to collapse or extend the assembly while subjected to operating torque. This excessive force may damage the drive shaft supports. The shield surfaces must be kept dry, as dirt accumulation on them will quickly cause these units to bind.

Care should also be taken to be certain the shields are not dented or damaged, as this will result in excessive forces being applied against the drive shaft. Damaged shields also cause obvious difficulties when installing the assembly. If at any time the shields do not turn freely, they should be checked to determine the cause and repaired immediately.

Wheels and Tires

Torque the wheel lug bolts to 120 ft. lbs.. Check the torque after every other load, until the torque does not decrease, and every 300 loads thereafter.

Check the tires periodically and maintain correct tire pressure. Do not exceed the maximum tire pressure that is indicated on the sidewall of the tire. Always check tire pressure with the spreader empty.

Remove the weight from the tires when storing the machine.

Index

BEFORE USE	5
DELIVERY REPORT	25
LUBRICATION	14-18
MAINTENANCE	
Apron	20
Apron Drive Shear Bolt	19
Drive Belt	20-21
Gearbox Drive Chains	19
General	22
Maintenance Record	24
PTO Assembly	22
Wheel Bearings	21
Wheel and Tires	22
OPERATION	
Attaching to the Tractor	8
Attaching the Vehicle (25G)	8
Feed Control Positions	10-12
General Information	6
Loading	9
Model 25G & 50G Ground Drive	7
SMV Emblem	5
Storage	13
Tractor Hitch	6
Tractor Size	6
Transporting	13
OWNER ASSISTANCE	1
SAFETY/CAUTION	4
SAFETY DECALS	3
SPECIFICATIONS	2
TO THE OWNER	1
TROUBLESHOOTING	27
WARRANTY	26

DELIVERY REPORT MANURE SPREADER

Owner's Name _____

Owner's Address _____

Dealer's Name _____

Dealer's Address _____

Machine _____

Model _____

Serial # _____

Optional equipment installed or delivered with unit.

Inst. Del. Inst. Del.

The Operator's Manual has been given to the owner and used to instruct him on these items checked below.

Dealer Representative's Signature _____

Delivery Date _____

- Safety Precautions
- Tractor Hitching
- Operation of Controls
- Field Operation
- Lubrication
- Machine Adjustments
- Maintenance Schedule
- Use of Optional Equipment
- Troubleshooting
- Non-Use Storage

"I have been instructed in the safety precautions, operation, care and maintenance of this machine as detailed in the Operator's Manual."

Owner's Signature _____

Date _____

Warranty

Pequea's Limited Warranty

Pequea Machine Company warrants to the original Purchaser all Machinery, Equipment, or Trailers manufactured by it, to be free from defects in material and workmanship under normal use and service. Its obligation under this Warranty shall be limited to replacement or repair of any parts thereof, free of charge to the original Purchaser, at its place of business, provided, however, that the part(s) to be replaced or repaired, shall within one (1) year after delivery to the original Purchaser, be demonstrated to be defective; which determination shall be made by the Company. The said components or parts must be returned through the Selling dealer or distributor directly to the Company with all transportation charges prepaid. Notice of defect shall be furnished in writing to the Seller and to the agent through whom the machinery was received, disclosing in full all known defects and failure in operation and use, and reasonable time shall be given to the Seller to remedy any such defects and failures. Failure to make such trial or give such notice shall be deemed an absolute acceptance by the Buyer and satisfaction in full of this Limited Warranty.

This Warranty does not cover, under any circumstances, any parts, components, or materials which, in the opinion of the Seller and Company, have been subjected to neglect, misuse, alteration, accident, or if repaired, with parts other than those manufactured by and obtained from Pequea Machine Company.

This Warranty does not cover components which are already covered by a separate Warranty provided by the supplier of said parts or components.

The Company's obligation under this Warranty is limited to repair or replacement, free of charge to the original Purchaser, of any part which in judgement of the Company is defective. This Warranty does not cover normal wear and tear.

THIS WARRANTY IS MADE EXPRESSLY IN LIEU OF ALL OTHER WARRANTIES, EXPRESSED OR IMPLIED, INCLUDING ANY WARRANTY OF MERCHANTABILITY AND FITNESS FOR USE AND PURPOSE AND OF ALL OTHER OBLIGATIONS OR LIABILITIES ON ITS PART AND ANY IMPLIED WARRANTY. AND IT NEITHER ASSUMES NOR AUTHORIZES ANY OTHER LIABILITY IN CONNECTION WITH A SALE OF THIS MACHINE. THIS WARRANTY SHALL NOT APPLY TO THIS MACHINE OR TO ANY PART THEREOF WHICH HAS BEEN SUBJECT TO ACCIDENT, NEGLIGENCE, ALTERATION, ABUSE, OR MISUSE.

The Company makes no Warranty whatsoever in respect to accessories or parts not supplied by the Company. The term "original Purchaser" as used in this warranty, shall be deemed that person for whom the Machine, Equipment, or Trailer is originally supplied. This Warranty shall apply only within the boundaries of the continental United States.

Under this Warranty, the Company cannot guarantee that existing conditions beyond its control will not affect its ability to obtain materials or manufacture necessary replacement parts.

No one is authorized to alter, modify, or change the terms of this Warranty in any manner.

The Company warrants the Construction of the equipment sold herein and will replace at its expense for a period of (1) year from the date hereof, any parts which prove defective as determined under the terms of this Limited Warranty.

Troubleshooting

Problem	Possible Cause	Correction
Apron chain breaking, or apron chain came off of sprockets or idler	Freezing conditions Bent apron slats	Always be sure apron is not frozen before starting PTO
	Loose apron chain this manual	Adjust chain as recommended in
Bending apron adjusting idler bracket and apron slats	Loose apron chain	Adjust chain as recommended in this manual
	Apron frozen to chain return	Be sure apron is free to move before operating
Drive belt slippage	Incorrect adjustment Belt",see Maintenance section. Misaligned sheaves.	Adjust belt as detailed in "Drive Align sheaves.
	Foreign material on belt.	Clean belt. Operate with shield installed. Engage PTO slowly with moderate engine speed. Do not load manure on beaters.
Spreader is moving but beaters won't spin	Drive Chain is broken or has jumped off the sprockets	Repair chain and realign with sprockets
Spreader pulls harder than normal; tires won't spin	Material has jammed in the beaters or the drive chain	With spreader stopped- Remove foreign material and check for any damage
PTO is spinning but the beaters won't turn	Drive shaft is broken	Replace
	Coupler is not engaging both shafts	Reposition coupler and reinstall bolt
	Drive chain is broken	Repair or replace
	Chain has jumped off of sprockets	Reposition chain and realign sprockets
Excessive wear or corrosion of apron chain	Lack of lubrication	Apron chains should be oiled liberally with used crankcase Oil twice yearly or every 300 loads. Oil frequently under highly corrosive conditions.
Shifter will not return to "L"	Return spring is weak	Replace spring.
Shifter will not go into gear. Grinding sound coming from shifter.	Cable not adjusted properly Cable broken Cable stretched	Adjust cable. Replace cable.
Shifter will not change gears	Shifting mechanism not working properly	Grease all moving parts with a graphite grease only Check service manual for correct adjustments

If there are any other service or repair problems please contact your dealer immediately.

Notes





Pequea Machine Inc. • A Skibo Company • 200 Jalyn Dr. • P.O. Box 399 • New Holland, PA 17557
717/354-4343 • fax: 717/354-8843 • email: pequea@frontiernet.net
www.pequeamachine.com