

# *Service Manual*



for the Gas and Electric  
Rethermalizer



Model Numbers

*RTG14&RTE14*

**Pitco Frialator**

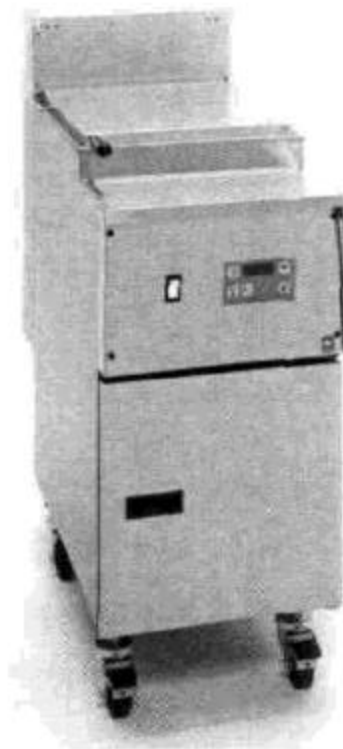

**PITCO FRIALATOR, INC.**  
P.O. BOX 501 CONCORD, NH 03302-0501  
Phone: 1(603)225-6684  
Toll Free: 1(800)258-3708  
Fax: 1(603)225-8497



## NOTICES

There are three different types of notices that you should be familiar with, a NOTICE, CAUTION, and WARNING. A NOTICE is a special note used to call attention to a particularly important point. CAUTION is used to point out a procedure or operation which may cause equipment damage. The WARNING notice is the most important of the three because it warns of an operation that may cause personal injury. Please familiarize yourself with your new Rethermalizer before operating it and heed the notices throughout this manual. The WARNINGS are listed below and on the following page for your review prior to operating the unit.

### FOR YOUR SAFETY

**DO NOT store or use gasoline or other flammable vapors or liquids in the vicinity of this or any other appliance.**

**WARNING: Improper installation, adjustment, alteration, service or maintenance can cause property damage, injury or death. Read the installation, operating and maintenance instructions thoroughly before installing or servicing this equipment.**

### TO THE PURCHASER

**POST IN A PROMINENT LOCATION INSTRUCTIONS TO BE FOLLOWED IN THE EVENT THAT AN OPERATOR SMELLS GAS. OBTAIN THIS INFORMATION FROM YOUR LOCAL GAS SUPPLIER.**

**SAFETY****WARNING**

This appliance is equipped with a three prong (grounding) plug. This is for your protection against shock hazard in the event of equipment malfunction. Always plug the unit directly into a properly grounded three-prong receptacle. DO NOT cut or remove the grounding (third) prong.

**WARNING**

DO NOT use an open flame to check for gas leaks! Keep all open flames away from the Rethermalizer until the installation is complete.

**WARNING**

A Rethermalizer equipped with casters and a flexible power cord, must be connected to the gas supply with a Quick-Disconnect device. This quick disconnect must comply with ANSI Z24.41. To limit the movement of the unit without depending on the connector or quick disconnect, a restraining cable must also be installed.

**WARNING**

There is an open gas flame inside the Rethermalizer. The unit may get hot enough to set nearby materials on fire. Keep the area around the unit free from combustibles.

**WARNING**

Ensure that the Rethermalizer can get enough air to keep the flame burning correctly. If the flame is starved for air it can give off a dangerous carbon monoxide gas. Carbon Monoxide is a clear odor-less gas that can cause suffocation.

**WARNING**

Carbon monoxide can build up if you block the flue. Blocking the flue will also cause the unit to overheat. DO NOT obstruct the flow of combustion/ventilation or air opening around the Rethermalizer. Ensure that you meet the minimum clearances specified in the installation instructions. Adequate clearance around the unit is necessary for servicing and proper burner operation.

**WARNING**

Wait 5 minutes before attempting to relight the pilot. This will allow for any gas in the unit to dissipate.

**SAFETY****SAFETY****SAFETY****SAFETY****WARNING**

The power supply must be disconnected before servicing or cleaning the appliance.

**WARNING**

DO NOT supply the fryer with a gas that is not indicated on the data plate. If you need to convert the fryer to another type of fuel, contact your dealer.

**WARNING**

The Rethermalizer must be properly restrained to prevent movement or tipping. This restraint must prevent the unit from movements that would splash hot liquids on personnel. This restraint may be by any means (alcove installation, adequate ties, or battery installation).

**WARNING**

DO NOT obstruct the flow of combustion/ventilation or air openings around the rethermalizer. Adequate clearance around the rethermalizer is necessary for servicing and proper burner operation. Ensure that you meet the minimum clearances specified in the installation instructions.

**WARNING**

The Rethermalizer must be properly restrained to prevent movement or tipping. This restraint must prevent the fryer from movements that would splash hot liquids on personnel. This restraint may be any means (alcove installation, adequate ties, or battery installation).

**WARNING**

NEVER supply the Rethermalizer with a gas that is not indicated on the data plate. Using the incorrect gas type will cause improper operation. If you need to convert the unit to another type of fuel, contact your dealer.

**THIS MANUAL MUST BE  
RETAINED FOR FUTURE  
REFERENCE**

**SAFETY****SAFETY****SAFETY****SAFETY****SAFETY**

# Table of Contents

Table of Contents	ii
TROUBLESHOOTING	1
Component Diagnosis	1
Digital Control	1
Computer	1
Water Level Control	1
Water Fill Solenoid	1
Safety Relay (K1)	2
Ignition Control Module	2
Temperature Probe	2
PARTS	3
General Parts	3
Heating Components	5
Front Panel Assembly	7
Tank and Fluid Components	9
Accessories	11
SCHEMATICS	14-17
RTG14 with Digital Control	14
RTE14 with Digital Control	15

## TROUBLESHOOTING

This section is provided to aid the Authorized Service Technician in the repair of your Rethermalizer.

SYMPTOM	POSSIBLE CAUSE
Display will not light	Bad Temperature Control, Fuse Holder, Fuse, Transformer or Switch
Maintains wrong temperature	Bad Probe or Display
Display lit, but does not heat	Bad K1 Relay, contactor, Probe, Display, Gas Valve or Elements or Water Level control.
Constantly fills, or will not fill	Bad K1 Relay, Level Sensor Seals, Level Control or Water fill solenoid. Manual bypass valve may be open.
Spark can be heard, Pilot does not light	Gas Valve Knob is NOT in the ON position? Plugge Pilot orifice. Bad Ignition Module or Gas Valve.
Pilot Lights but mains do not.	Bad Gas Valve or Ignition Module.

### **Component Diagnosis:**

Before diagnosing any individual components, all appropriate power supplies and wiring terminations must be checked. Follow the appropriate section below to diagnose the suspected components.

#### Digital Control:

When 24 VAC is supplied to the Temperature Control, and the control is turned on the display should be lit. When the water temperature is below the SET Temperature (195°F) 24 VAC Heat Demand signal can be found between the Gray and Green/Yellow wires at the rear of the controller. The Red LED Heating indicator light will be ON. When problems with the Temperature Control occur it is important that the Probe be checked also.

#### Computer Control:

When 24VAC is supplied to the control the display should be lit. When the water temperature is below the SET Temperature (195°F) a 24VDC Heat Demand signal can be found at the coil of the Heat Demand Relay located behind the computer.

#### Water Level Control:

Check for 24 VAC between the COM and 24 V PWR (Power) terminals. Disconnect the HIGH, LOW and COM terminals, a 24 VAC signal can now be seen between the N.C. and COM terminals. The safety Relay (K1) and the Water Fill Solenoid will energize. Using a jumper wire, short the HIGH, LOW and COM terminals together, this will cause the Control to stop the 24 VAC signal between the N.C. and 24 V PWR terminals.

Water Fill Solenoid:

The Water Fill Solenoid should be open when a 24 VAC signal is applied to the two wires leading to the Actuator. With no voltage present the Solenoid should be closed.

Safety Relay (K1):

With a 24 VAC signal present at the coil section of the relay the switch section should have closed the circuit between the two Gray wires.

Ignition Control Module:

When the Ignition Control Module receives 24VAC it will send a signal to the spark ignitor at the pilot assembly. The Module will also send 24VAC to the Pilot Solenoid at the Gas Valve. The pilot will light and the Pilot Flame Sensor will send a 0.15-0.35 micro amp signal to the Ignition Module at which time the ignition module will cease the pilot spark and send a 24VAC signal to the Main Solenoid at the Gas Valve. To test the system look and listen for the above ignition steps and check for the appropriate signals.

Temperature Probe:

Unplug the wiring harness from the rear of the Temperature Control. Measure the resistance between the two black wires on the harness in the cooker, NOT the harness at the control. Measure the water temperature (with an independent temperature meter or thermometer) and the resistance of the probe at the same time. Consult the chart below for probe specifications.

Temperature °F	Resistance Ohms
70°F	108050
80°F	84643
90°F	66823
100°F	53145
110°F	42568
120°F	34328

Temperature °F	Resistance Ohms
130°F	27862
140°F	22755
150°F	18694
160°F	15446
170°F	12832
180°F	10716

Temperature °F	Resistance Ohms
190°F	8994
195°F	8255
200°F	7585
210°F	6427
212°F	6221

If the resistance varies more than 20% from that specified in the chart the probe should be changed. It is more important that the probe resistance be correct at 212°F than 70°F, therefore there can be more tolerance given at 70°F than at 212°F.

# PARTS

## General Parts:

Item #	QTY/ Unit	Part Number	Description	Gas/Electric
1	1	B3310502-C	Tank	Gas
	1	B3402201	Tank	Electric
2	1	B1811501	Cabinet, Painted	Gas
	1	B1811503	Cabinet, Painted	Electric
3	1	A1619202	Back Strip	Gas
4	1	B2301109	Door	Gas/Electric
5	1	B7230302	Hinge, Bottom Right Hand Door	Gas/Electric
6	1	B7230202	Hinge, Top Right Hand Door	Gas/Electric
7	2	P6071483	Plug, Hole	Gas/Electric
8	2	PP10025	Screw	Gas/Electric
9	1	PP11006	Handle	Gas/Electric
10	1	P6071300	Magnet	Gas/Electric
11	1	A1819602	Bracket, Door Magnet	Gas/Electric
12	1	B3609901	Edge, Marine	Gas/Electric
13	1	A1822101	Cabinet Spacer, Tank Holder	Gas/Electric
14	1	A4103602	Splash Back	Gas
	1	A4103902	Splash Back	Electric
15	4	P0075300	Screw, 3 #10 x 5/8" Self Drill	Gas/Electric
16	2	PP10728	Caster With Brake	Gas/Electric
17	2	PP10652	Caster Without Brake	Gas/Electric
18	4	A3901101	Caster Mounting Plate	Gas/Electric
19	16	P0020600	Bolt 1/4-20	Gas/Electric
20	16	P0093300	Nut 1/4-20	Gas/Electric

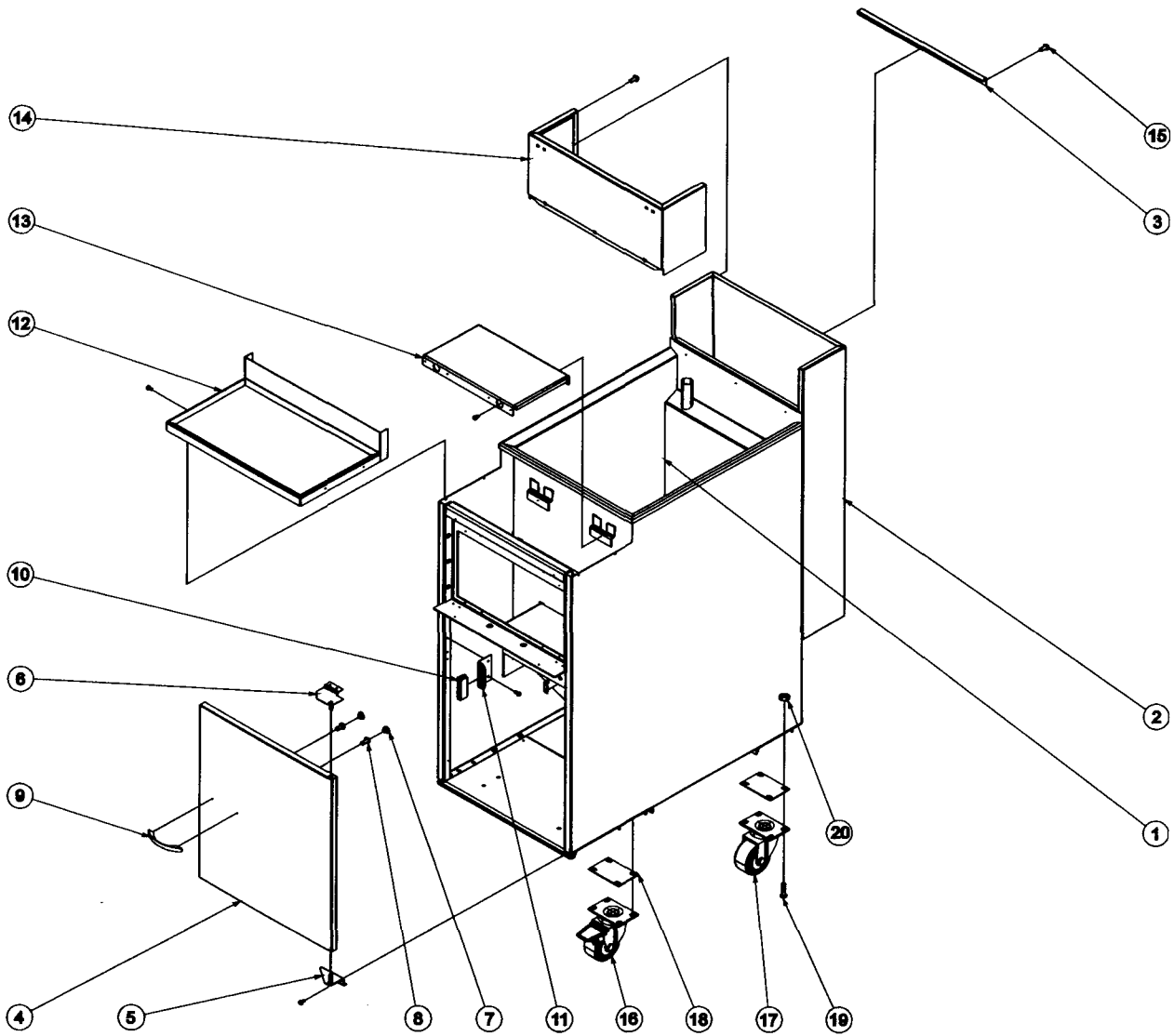

General Parts



**Heating Components:**

Item #	QTY/ Unit	Part Number	Description	Gas/Electric
1	1	P6071767	Gas Shut-Off Valve	Gas
2	1	P6071450	Pilot Assembly, Nat	Gas
3	2	PP10665	Screw 10-24x3/8" SS	Gas
4	2	PP10665	Screw 10-24x3/8" SS	Gas
5	1	A3306402	Pilot Bracket	Gas
6	2	P0092300	Nut, Keep 10-24	Gas
7	1	PP10271	High-Limit	Gas
8	1	A1815501	Bracket, High-Limit	Gas
9	1	A8000801	Bracket, Manifold Mounting RH	Gas
10	1	A8013101	Bracket, Thermostat & Unitrol Extension ,	Gas
11	1	B7510102	Extension, Gas Valve Knob	Gas
12	1	B8009501	Manifold, Burner	Gas
13	1	A8000801	Bracket, Manifold Mounting LH	Gas
14	1	A4012801	Clamp, Unitrol Bracket	Gas
15	1	P0063500	Screw, Square Head 6-32	Gas
16	2	A8001001	Air Collar	Gas
17	2	PP10025	Screw, Air Collar Set	Gas
18	2	P6071050	Burner	Gas
19	4	PP10195	Bolt, Burner Mounting, 1/4-20	Gas
20	1	A1401002	Clamp, Bulb and Probe	Gas
21	2	PP10698	Screw, 10-24 Round Head SS	Gas
22	1	A3701002	Heat Shield, Burner	Gas
23	2	P6071341	Orifice, NAT	Gas
	2	P6071353	Orifice, LP	Gas
24	1	P5045638	Gas Valve 24V NAT	Gas
	1	P5045639	Gas Valve 24V LP	Gas
25	2	A8001101	Fittings, Burner	Gas
26	2	P6071267	Knob, Gas Valve	Gas
27	1	P5045660	Bracket	Gas
28	1	B6779850	Unitrol Limit Wires	Gas
29	1	P5047541	Thermopile	Gas

Not Shown

3	PP10953	Elements 208/220/240V .....	Electric
---	---------	-----------------------------	----------

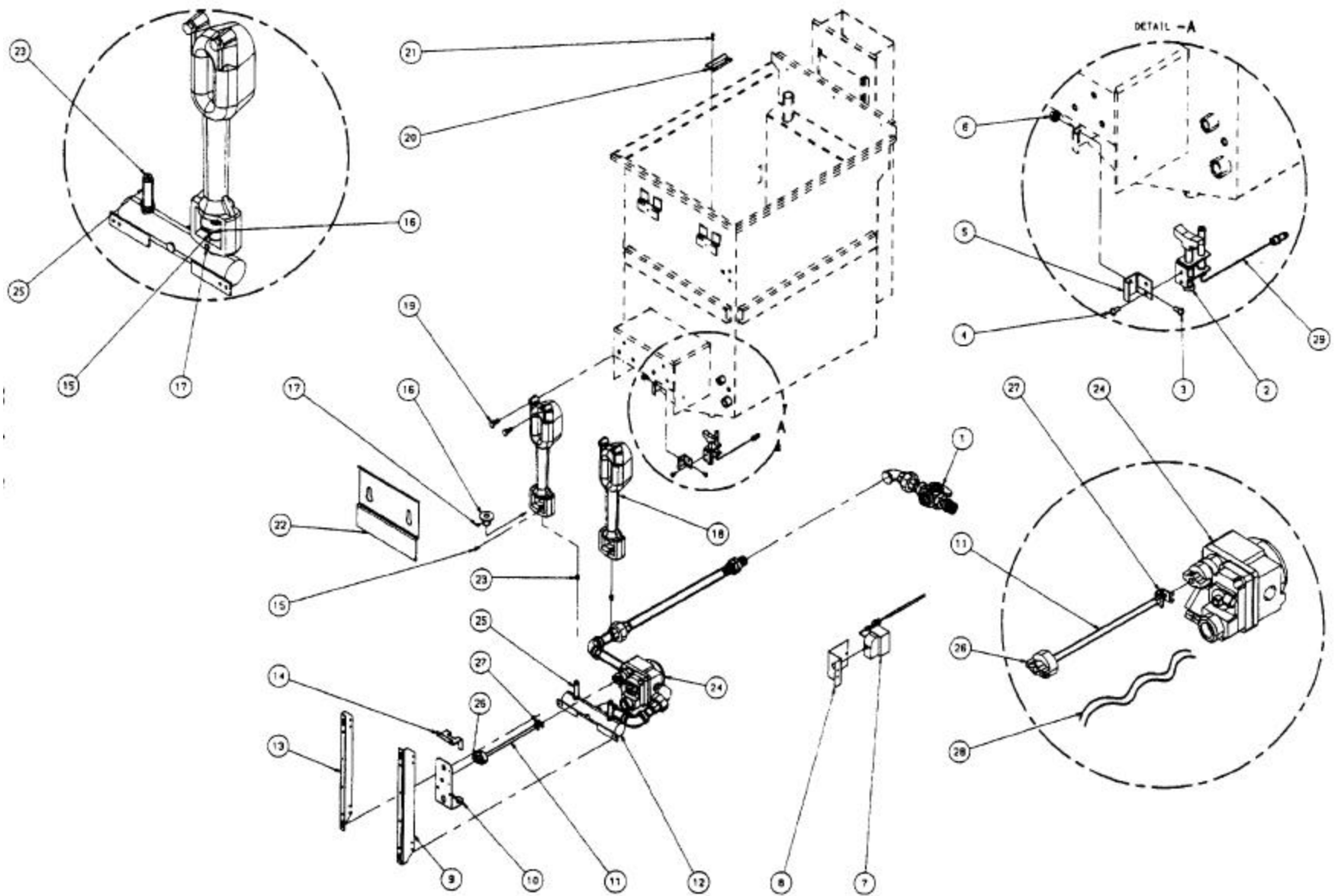

Heating Components

**Front Panel Assembly:**

Item #	Qty/ Unit	Part Number	Description	Gas/Electric
1	1	B3609601	Front Panel Weldment	Gas/Electric
2	2	P0075300	Screw 3 10 x 5/8" Self Drill	Gas/Electric
3	1	A3635002	Bezel Front Panel	Gas/Electric
4	1	PP10939	Thermostat With 24V Display	Gas/Electric
5	4	PP10195	Screw, Button Head Hex	Gas/Electric
6	1	PP10654	Switch, Rocker SPST	Gas/Electric
7	1	A6054501	Label, Switch	Gas/Electric
8	1	PP10122	Fuse, 1 Amp Slow Blow, Glass	Gas
	1	P5045717	Fuse, 2 Amp Slow Blow, Glass	Gas/Electric
9	2	P5045794	Fuse Holder	Gas
	1	P5045794	Fuse Holder	Electric
10	1	B6718701	Probe, Temperature Sensing	Gas/Electric
11	1	PP 10439	Cable, Power With Plug	Gas/Electric
12	1	PP10146	Strain Relief 90°	Gas/Electric
13	1	PP10210	Transformer Multi to 24 VAC	Gas/Electric
14	8	PP10749	Screw 6-32 x 5/8	Gas/Electric
15	1	PP10702	Control, Liquid Level	Gas
	1	PP10981	Control, Liquid Level	Electric
16	1	P5046691	Relay 120 VAC SPST	Gas
	1	P5046688	Relay 24 VAC SPST	Electric
17	2	P6071071	Wire Clamp	Gas/Electric
18	1	P6071223	Grommet	Gas/Electric
19	4	PP 10749	Screw 6-32 x 5/8" SS	Gas/Electric
20	9	P0091400	Nutsert 6-32	Gas/Electric
21	1	A2948301	Entrance Box	Gas/Electric
22		P5045240	Clamp, Romex	Gas/Electric
23		B6714301	Harness, Control Cable	Gas
		B6731302	Harness, Entrance Box	Electric
24		B6714101	Harness, Front Panel	Gas/Electric
		B6731402	Harness, Front Panel	Electric

Not Shown

1	PP10560	Contactora, 24 VAC, 3 Pole .....	Electric
2	P5047302	Terminal Block.....	Electric

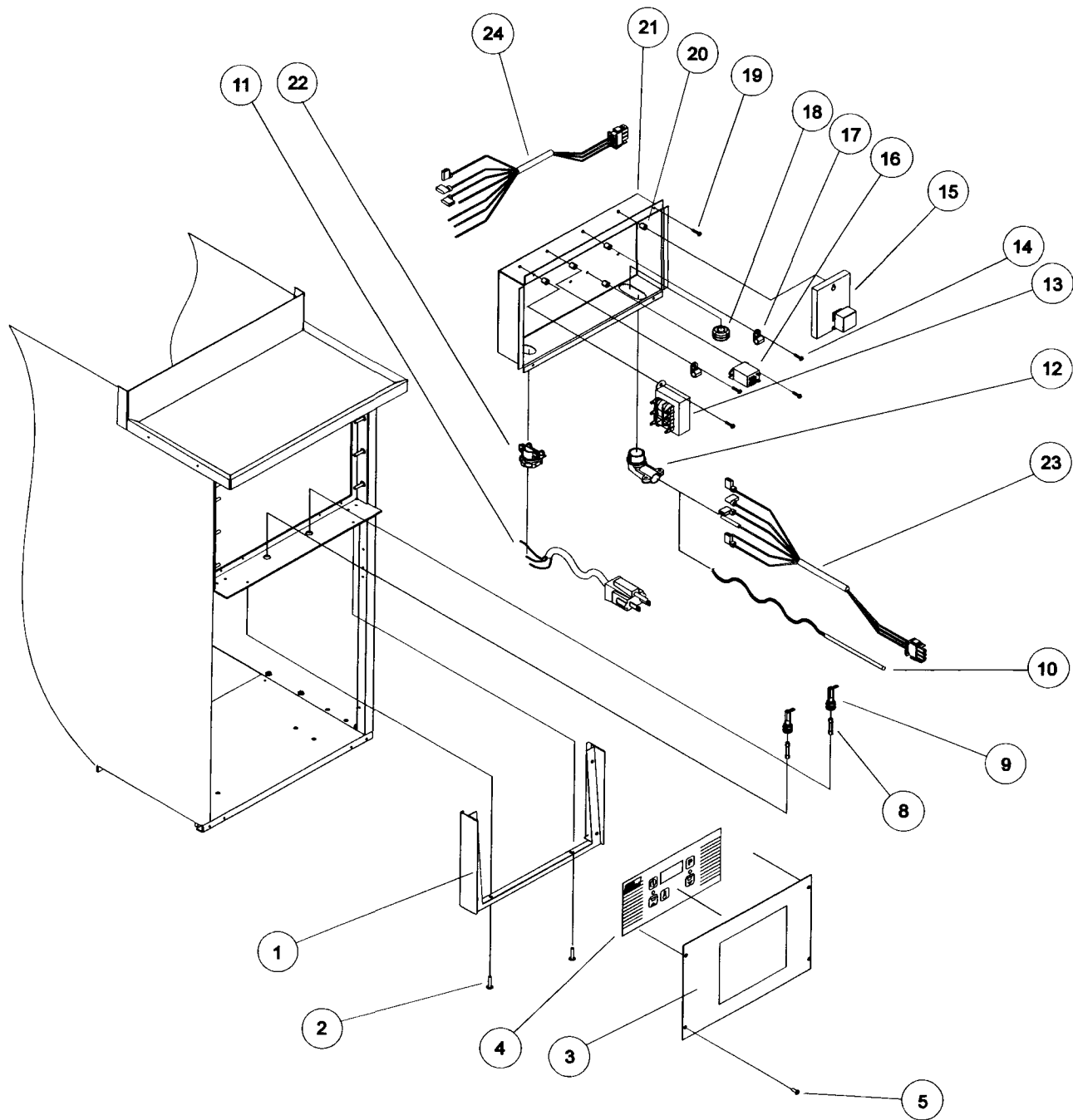

**Front Panel Assembly**

**Tank and Fluid Components:**

Item	Qty/ Unit	Part Number	Description	Gas/Electric
1	1	PPI0565	Drain Valve, SS	Gas/Electric
2	1	B4000802	Handle Assembly	Gas/Electric
3	2	B8015102	Connector, Drain Outlet	Gas/Electric
4	2	B8015202	Tube Drain Outlet	Gas/Electric
5	2	PP10034	Clamp	Gas/Electric
6	1	PP10032	Gasket	Gas/Electric
7	2	PP10620	Clamp, Worm type	Gas/Electric
8	1	A3318602	Hose, Overflow	Gas/Electric
9	1	PPI0747	Solenoid, Water Fill	Gas
	1	PP10982	Solenoid, Water Fill	Electric
10	1	PPI0742	Filter	Gas/Electric
11	1	PP10753	Valve, Ball 3/8" Bronze	Gas/Electric
12	1	PP10726	Valve, Check (Non Return)	Gas/Electric
13	4	PP10663	Plug, SS 1/4 NPT	Gas
14	1	A3318002	Deflector, Water Inlet	Gas/Electric
15	1	A3318102	Shield, Probe	Gas/Electric
16	2	P0142000	Nut, Acom 10-24 SS	Gas/Electric
17	2	PPI0698	Screw, 10-24 x 5/8 SS	Gas/Electric
18	4	PPI0666	Washer, Nylon	Gas/Electric
19	2	PP10667	Washer, Shoulder Nylon	Gas/Electric
20	2	P0092300	Nut, Keep 10-24	Gas/Electric

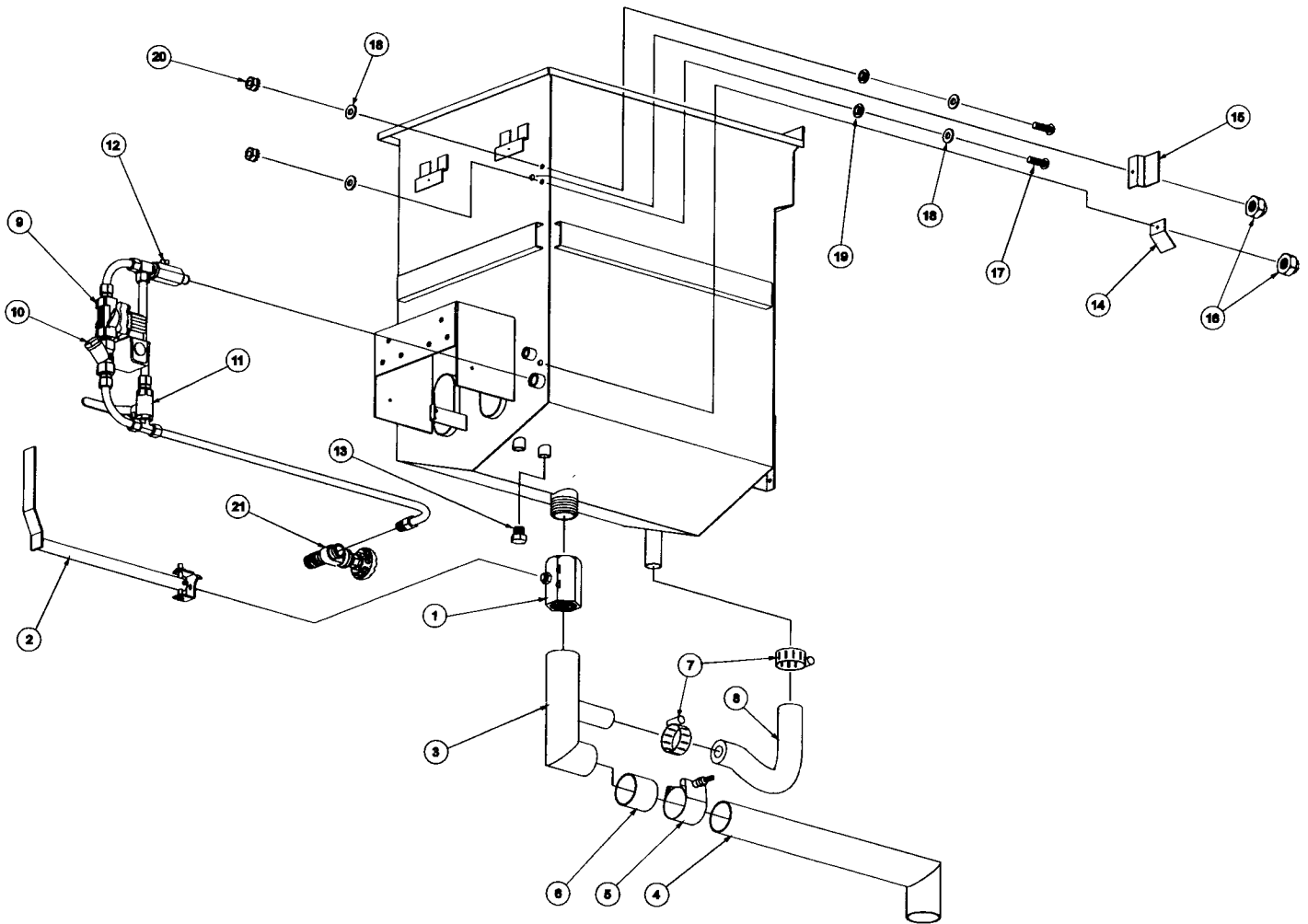

**Tank and Fluid Components**

Accessories:

Item #	Qty/Unit	Part Number	Description	Gas/Electric
1	1	A3317902	Cover	Gas/Electric
2	1	A4509301	Tube Rack	Gas
3	1	B4509402	Taco Rack	Gas/Electric
4	2	A5053602	Pan Holder End	Gas/Electric
5	1	A3318704	Hinge rod	Gas/Electric
6	1	A3317802	Support Hinge Rod	Gas/Electric
7	1	B3311001	Catch, Cover - LH	Gas/Electric
8	1	B3311002	Catch, Cover - RH	Gas/Electric
9	1	P6071251	Handle	Gas/Electric
10	2	PP10670	Bolt 1/4-20 x 1" SS	Gas/Electric
11	1	P0048980	Screw, 10-32 with 1" shoulder	Gas/Electric
12	3	PP10698	Screw, 10-24x5/8" SS	Gas/Electric
13	2	PP 10668	Nut, Acorn 1/4-20	Gas/Electric
14	2	PP10669	Nut 1/4-20 SS	Gas/Electric
15	1	PP10673	Washer, Split Lock 1/4" SS	Gas/Electric
16	1	PP10729	Screw 1/4-20x3/8" SS	Gas/Electric
17	1	PO112000	Screw, 10-24 x 1/2" SS	Gas/Electric
18	1	PO142000	Nut, Acorn 10-24 SS	Gas/Electric
19	1	A5053702	Pan Holder Center - Dual Units <i>Only</i>	Gas/Electric
Basket 1		B4511101	Basket, Suitcase.....	Gas/Electric
Basket 2		B4511501	Basket, Narrow.....	Gas/Electric
Basket 3		B4511601	Basket, Wide.....	Gas/Electric

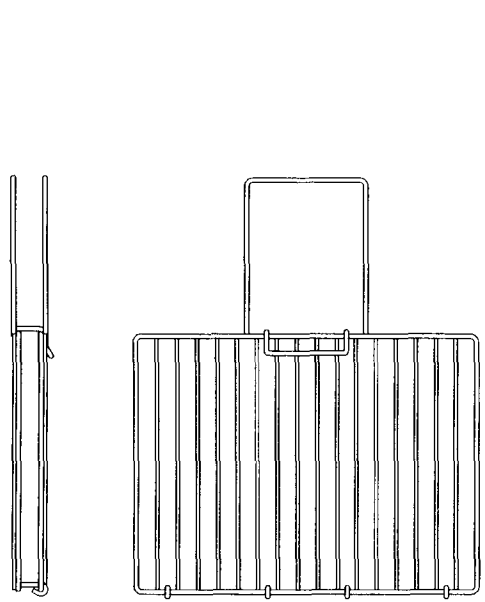
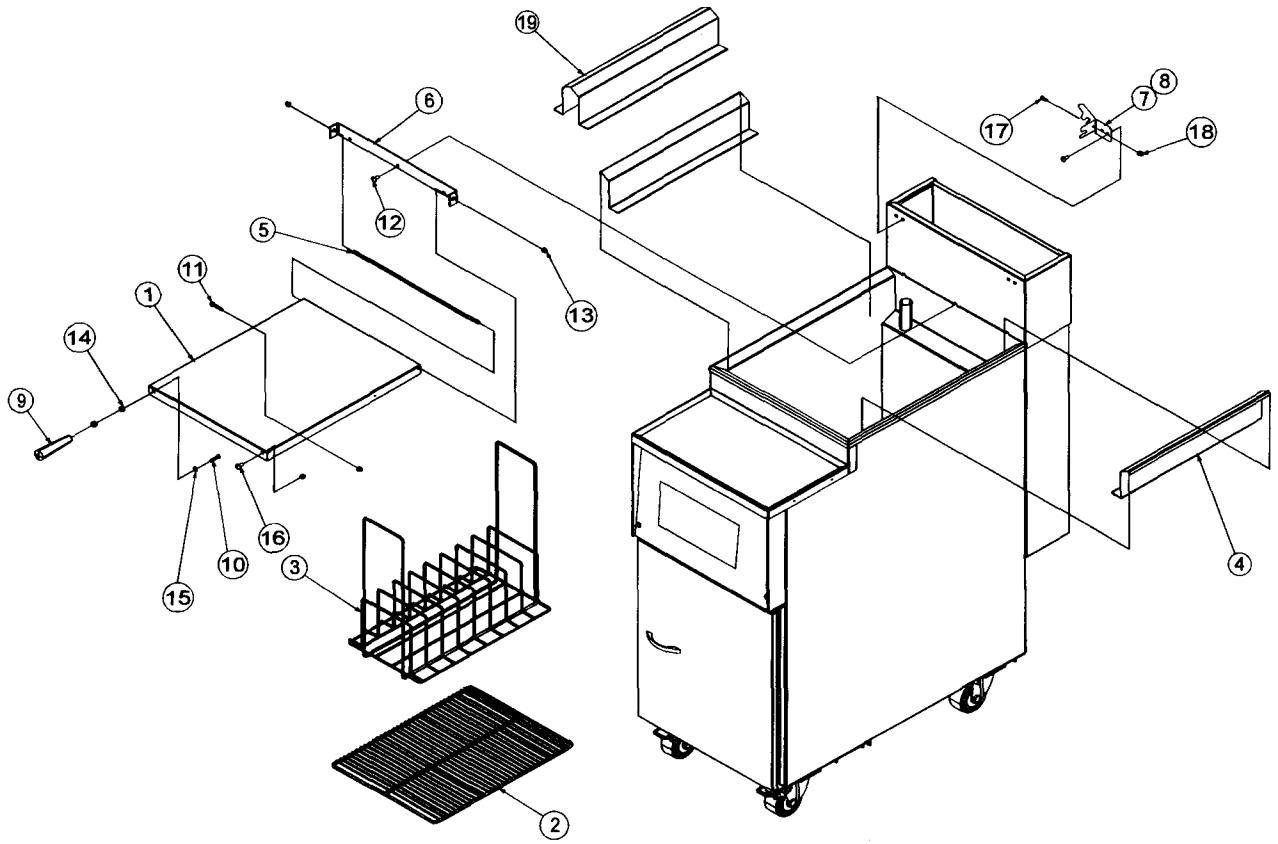

**Basket 1**

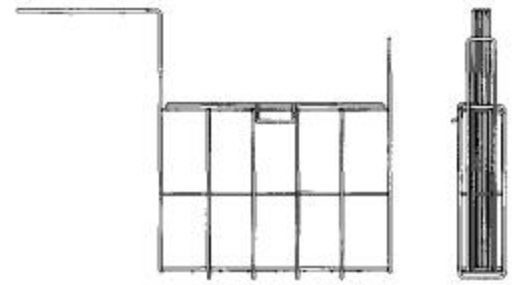

**Basket 2**

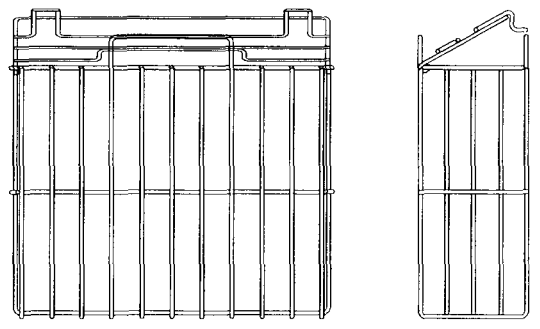

**Basket 3**

**Accessories**



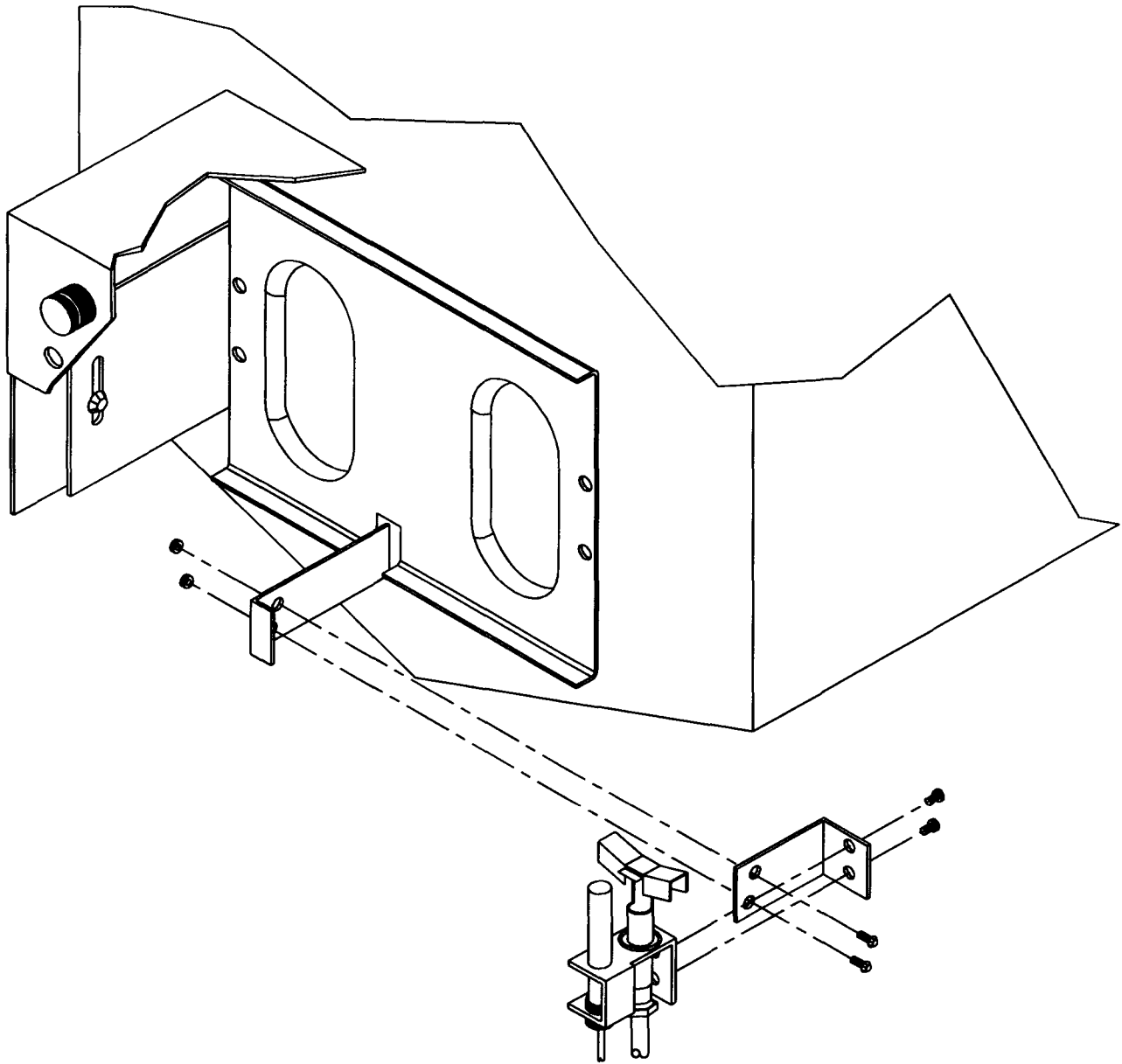

Drawing showing the location of the Pilot Assembly with the Burner Shield in place.

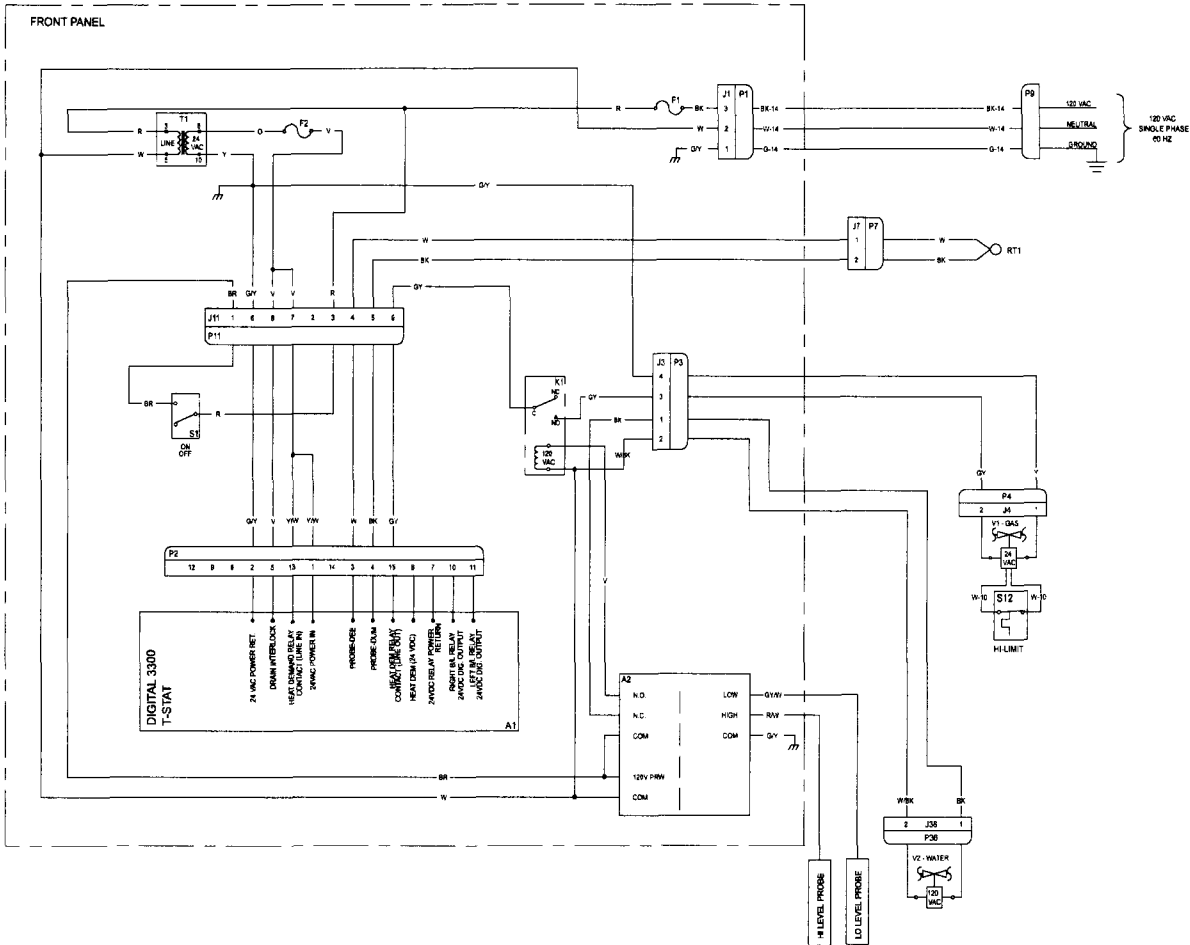

K1	P5046691	RELAY, 120 VAC - SPDT W/MTG TABS
V2	PP 0682	VALVE, WATER - 120V SOLENOID
A2	PP 0797	CONTROLLER, LIQUID LEVEL-RELAY
A1	PP 0949	THERMOSTAT, DIGITAL - 24V
RT1	PP 0939	PROBE, TEMPERATURE
S1	PP 0654	SWITCH, ROCKER-SPST (ON-OFF)
P3	PP10202	CONNECTOR, PLUG-4 PIN MOLEX
J3	PP10203	CONNECTOR, JACK- * SKT MOLEX
F1	PP10122	FUSE, GLASS-1 AMP SLOW BLOW
T1	PP10210	XFMR, 40VA - 120/208/240V TO 24V
S12	PP10084	SWITCH, HIGH TEMPERATURE LIMIT
P11	P504S860	CONNECTOR, PLUG-9 PIN MOLEX
P2		CONNECTOR, PLUG-15 PIN MOLEX
P1	PP10090	CONNECTOR, PLUG-3 PIN MOLEX
P4,P7,P36	P5045829	CONNECTOR, PLUG-2 PIN MOLEX
P9	PP10439	CORD, PLUG-MOLD 14-3 NEMA 5-15P
J1	PP10089	CONNECTOR, JACK-3 SKT MOLEX
J11	P5045838	CONNECTOR, JACK-9 SKT MOLEX
F2	P5045717	FUSE, 2 AMP-SLOW BLOW (GLASS)
V1	P5045638	VALVE, GAS UNITROL BMSER 24 VAC (NAT)
	P5045639	VALVE, GAS UNITROL BMSER 24 VAC (PRO)
J4,J7,J36	P5045839	CONNECTOR, JACK-2 SKT MOLEX
NOMENCLATURE	PART NO	DESCRIPTION
PARTS LIST		

NOTES:

1. UNLESS OTHERWISE SPECIFIED ALL WIRES ARE 18 AWG.
2. AT FUSES F1 AND F2, USE FUSE HOLDER (P5M5T94).
3. JUMPER TERMINAL +5 TO TERMINAL -3 ON A1 FOR PROGRAMMING.

USED ON		NEXT ASSY		DATE		DATE		DATE		DATE	
B	REV	DWO	APPROVAL	N	LAMBERT	10/98					
4822	REN NO	4/22/98	DATE								
T	DR	4774	4/29/98								
CK	DR										
APPD	DR										

PITCO FRIALATOR, INC.  
P.O. BOX 561 CONROE, TX 75338-0561

SCHEMATIC, RTG14 WITH 3300

PART NO: N/A  
SCALE: NONE  
SH 1 OF 1

D 700254 B

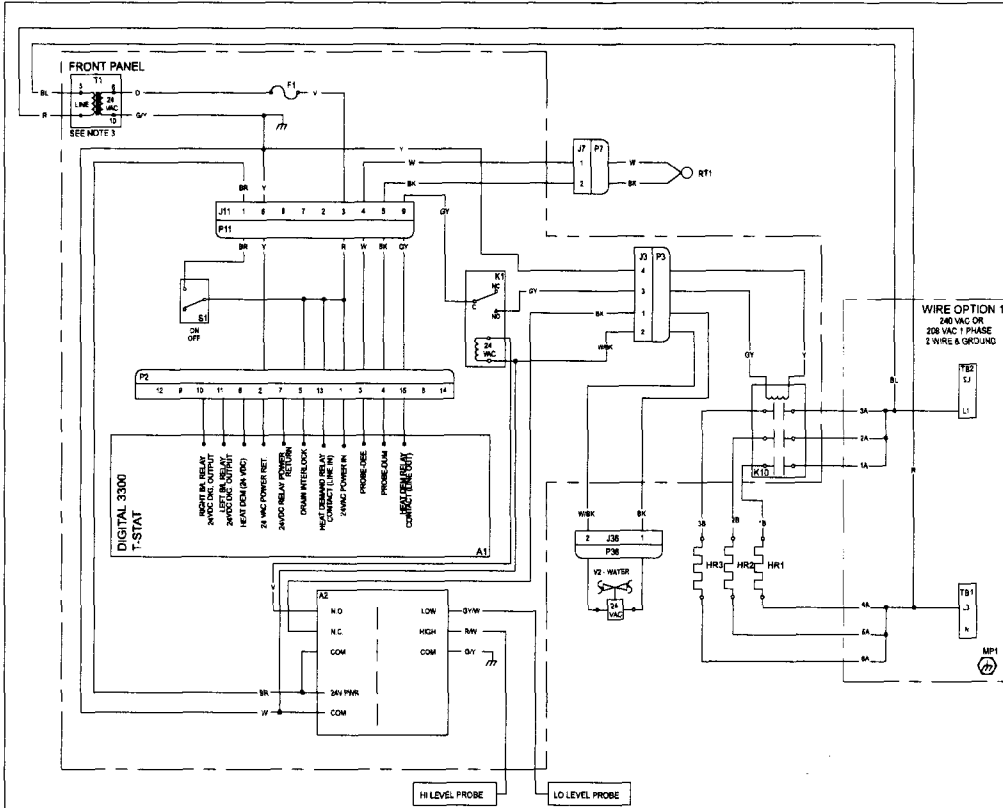
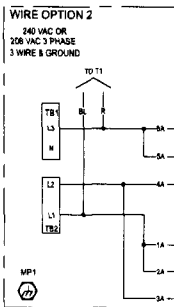
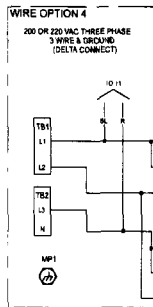
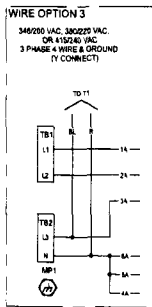
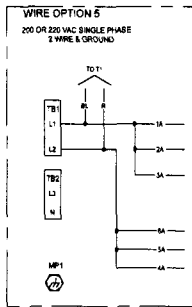

TABLE			
VOLTAGE	LINE/AMPS	PP10983	HR1-HR3
220		PP10983	8.0KV
3 PHASE	L1-38 AMPS	PP10983	2.7KW/LEM
2 WIRE & GND	L2-38 AMPS	PP10983	10.8KV
220		PP10983	3.5KW/LEM
3 PHASE	L1-44 AMPS	PP10983	10.8KV
2 WIRE & GND	L2-44 AMPS	PP10983	2.7KW/LEM
220		PP10983	8.0KV
3 PHASE	L1-22 AMPS	PP10983	2.7KW/LEM
2 WIRE & GND	L2-22 AMPS	PP10983	10.8KV
220		PP10983	3.5KW/LEM
3 PHASE	L1-28 AMPS	PP10983	10.8KV
2 WIRE & GND	L2-28 AMPS	PP10983	2.7KW/LEM
220		PP10983	8.0KV
3 PHASE	L1-41 AMPS	PP10983	2.7KW/LEM
2 WIRE & GND	L2-41 AMPS	PP10983	10.8KV
220		PP10983	3.5KW/LEM
3 PHASE	L1-34 AMPS	PP10983	8.0KV
2 WIRE & GND	L2-34 AMPS	PP10983	3.0KW/LEM
220		PP10983	8.0KV
3 PHASE	L1-14 AMPS	PP10983	3.0KW/LEM
2 WIRE & GND	L2-14 AMPS	PP10983	3.0KW/LEM
220		PP10983	8.0KV
3 PHASE	L1-15 AMPS	PP10983	12.0KV
2 WIRE & GND	L2-15 AMPS	PP10983	3.0KW/LEM
220		PP10983	8.0KV
3 PHASE	L1-37 AMPS	PP10983	2.8KW/LEM
2 WIRE & GND	L2-37 AMPS	PP10983	2.8KW/LEM
220		PP10983	8.0KV
3 PHASE	L1-21 AMPS	PP10983	7.4KV
2 WIRE & GND	L2-21 AMPS	PP10983	2.5KW/LEM
220		PP10983	8.0KV
3 PHASE	L1-12.3 AMPS	PP10983	7.4KV
2 WIRE & GND	L2-12.3 AMPS	PP10983	2.9KW/LEM

NOTES:

- UNLESS OTHERWISE SPECIFIED ALL WIRES ARE 18 AWG.
- AT FUSE F1, USE FUSE HOLDER (P5045794).
- FOR 240 VAC UNITS, CONNECT RED WIRE TO PIN 1 ON T1.  
FOR 220 VAC UNITS, CONNECT RED WIRE TO PIN 1 ON T1.  
FOR 208 VAC UNITS, CONNECT RED WIRE TO PIN 2 ON T1.



NOMENCLATURE	PART NO.	DESCRIPTION
V2	PP10982	VALVE WATER - 24V SOLENOID
TB1, TB2	P5047302	TERM BLOCK, 2 POST-ENTRANCE
T1	PP10210	XFMR, 40VA - 120/208/240V TO 24V
S1	PP10854	SWITCH, ROCKER-SPST (ON-OFF)
RT1	PP10949	PROBE, TEMPERATURE
P11	P5045860	CONNECTOR, PLUG-2 PIN MOLEX
P4, P7, P36	P5045829	CONNECTOR, PLUG-2 PIN MOLEX
MP1	P5045241	LUG, GROUND #6-2AWG
K10	PP10560	CONTACTOR, DEF PURP-40AMP 24 VAC 3PST-NO
K1	P5046688	RELAY, 24 VAC - SPDT WMTG TABS
J11	P5045838	CONNECTOR, JACK-8 SKT MOLEX
J4, J7, J36	P5045839	CONNECTOR, JACK-2 SKT MOLEX
HR1, HR2, HR3	PP10953	ELEMENT, TUBULAR
F1	P5045717	FUSE, 2 AMP-SLOW BLOW (GLASS)
A2	PP10981	CONTROLLER, LIQUID LEVEL - 24V RELAY
A1	PP10939	THERMOSTAT, DIGITAL 24V

PARTS LIST			
USED ON	NEXT ASSY	REV	DATE
4822	4796	BN	1/98
4229WB	47169B	DATE	4/98
T.F.	KALL	DR	4/74
	MWC	CK	4/98
	MWC	APP	4/98

**PITCO FRIALATOR, INC.**  
 P.O. BOX 887, CONCORD, NH 03303-0087  
**SCHMATIC, RTE14 WITH 3300**  
 PART NO: N/A  
 SCALE: NONE SH 1 OF 1  
 D 700255 C