

SHARP SERVICE MANUAL

No. 00ZUX44U//SME



Illustration: UX-44

FACSIMILE

UX-44 MODEL FO-55

Parts of this service manual are omitted because it is partly common to FO-77U/UX-66U of the service manual of the previous issue. Those common parts are referred to in the service manual of FO-77U/UX-66U (00ZFO77U//SME).

CONTENTS

CHAPTER 1. GENERAL DESCRIPTION

- [1] Specifications 1-1
- [2] Operation panel 1-2
- [3] Transmittable documents 1-3
- [4] Installation 1-4
- [5] Quick reference guide 1-9
- [6] Quick setup guide (UX-44U only) 1-10

CHAPTER 2. ADJUSTMENTS

- [1] Adjustments 2-1
- [2] Diagnostics and service soft switch 2-2
- [3] Troubleshooting 2-18
- [4] Error code table 2-19

CHAPTER 3. MECHANISM BLOCKS

- [1] General description 3-1
- [2] Disassembly and assembly procedures 3-3

CHAPTER 4. DIAGRAMS

- [1] Block diagram 4-1
- [2] Wiring diagram 4-2
- [3] Point-to-point diagram 4-3

CHAPTER 5. CIRCUIT DESCRIPTION

- [1] Refer to the service manual of FO-77U.
- [2] Refer to the service manual of FO-77U.
- [3] Refer to the service manual of FO-77U.
- [4] Circuit description of power supply PWB 5-12
- [5] Circuit description of CIS unit 5-12

CHAPTER 6. CIRCUIT SCHEMATICS AND PARTS LAYOUT

- [1] Control PWB circuit 6-1
- [2] TEL/LIU PWB circuit 6-9
- [3] Power supply PWB circuit 6-13
- [4] Operation panel PWB circuit 6-17

CHAPTER 7. OPERATION FLOWCHART

- [1] Refer to the service manual of FO-77U.
- [2] Refer to the service manual of FO-77U.

CHAPTER 8. OTHERS

- [1] Refer to the service manual of FO-77U.
- [2] Refer to the service manual of FO-77U.

PARTS GUIDE

Parts marked with "⚠" are important for maintaining the safety of the set. Be sure to replace these parts with specified ones for maintaining the safety and performance of the set.

CAUTION FOR BATTERY REPLACEMENT

- (Danish) ADVARSEL !
Lithiumbatteri-Eksplosionsfare ved fejlagtig håndtering.
Udskiftning må kun ske med batteri af samme fabrikat og type.
Levér det brugte batteri tilbage til leverandoren.
- (English) Caution !
Danger of explosion if battery is incorrectly replaced.
Replace only with the same or equivalent type
recommended by the equipment manufacturer.
Discard used batteries according to manufacturer's
instructions.
- (Finnish) VAROITUS
Paristo voi räjähtää, jos se on virheellisesti asennettu.
Vaihda paristo ainoastaan laitevalmistajan suosittelemaan
tyyppiin. Hävitä käytetty paristo valmistajan ohjeiden
mukaisesti.
- (French) ATTENTION
Il y a danger d'explosion s' il y a remplacement incorrect
de la batterie. Remplacer uniquement avec une batterie du
même type ou d'un type recommandé par le constructeur.
Mettre au rebut les batteries usagées conformément aux
instructions du fabricant.
- (Swedish) VARNING
Explosionsfare vid felaktigt batteribyte.
Använd samma batterityp eller en ekvivalent
typ som rekommenderas av apparattillverkaren.
Kassera använt batteri enligt fabrikantens
instruktion.
- (German) Achtung
Explosionsgefahr bei Verwendung inkorrektter Batterien.
Als Ersatzbatterien dürfen nur Batterien vom gleichen Typ oder
vom Hersteller empfohlene Batterien verwendet werden.
Entsorgung der gebrauchten Batterien nur nach den vom
Hersteller angegebenen Anweisungen.

CHAPTER 1. GENERAL DESCRIPTION

[1] Specifications

Automatic dialing:	Rapid Key Dialing: 5 numbers Speed Dialing: 35 numbers	Effective scanning width:	8.3" (210 mm) max.
Thermal paper:	Initial starter roll (included with machine): 32 ft. (10 m) Recommended replacement roll: FO-20PRw, 98 ft. (30m), 0.5" core	Effective printing width:	8.3" (210 mm) max.
Paper cutting method:	Tear off by hand	Contrast control:	Automatic/Dark selectable
Modem speed:	9600 bps with automatic fallback to lower speeds	Reception modes:	Fax/Tel
Transmission time* :	Approx. 15 seconds	Copy function:	Yes
Resolution:	Horizontal: 203 pels/inch (8 dots/mm) Vertical: Standard: 98 lines/inch (3.85 lines/mm) Fine/Halftone: 196 lines/inch (7.7 lines/mm) Super fine: 391 lines/inch (15.4 lines/mm)	Telephone function:	Yes (cannot be used if power fails)
Automatic document feeder:	5 pages max. (20 lb paper)	Power requirements:	120 V AC, 60 Hz
Halftone (grayscale):	64 levels	Operating temperature:	41 - 95°F (5 - 35°C)
Display:	16-digit LCD display	Humidity:	Maximum: 85 % RH
Compression scheme:	MR, MH, Sharp (H2)	Power consumption:	Standby: 3.6 W Maximum: 100 W
Applicable telephone line:	Public switched telephone network	Dimensions:	Width: 12.0" (304 mm) Depth: 9.3" (236 mm) Height: 4.8" (122 mm)
Compatibility:	ITU-T (CCITT) G3 mode	Weight:	Approx. 5.7 lbs. (2.6 kg)
Input document size:	Automatic feeding: Width: 5.8 to 8.5" (148 to 216 mm) Length: 5.5 to 11" (140 to 279 mm) Manual feeding: Width: 5.8 to 8.5" (148 to 216 mm) Length: 5.5 to 23.6" (140 to 600 mm)	* Based on ITU-T (CCITT) Test Chart #1 at standard resolution in Sharp special mode, excluding time for protocol signals (i.e., ITU-T phase C time only).	
		Note: The facsimile machine is Year 2000 compliant.	

As a part of our policy of continuous improvement, SHARP reserves the right to make design and specification changes for product improvement without prior notice. The performance specifications figures indicated are nominal values of production units. There may be some deviation from these values in individual units.

[2] Operation panel

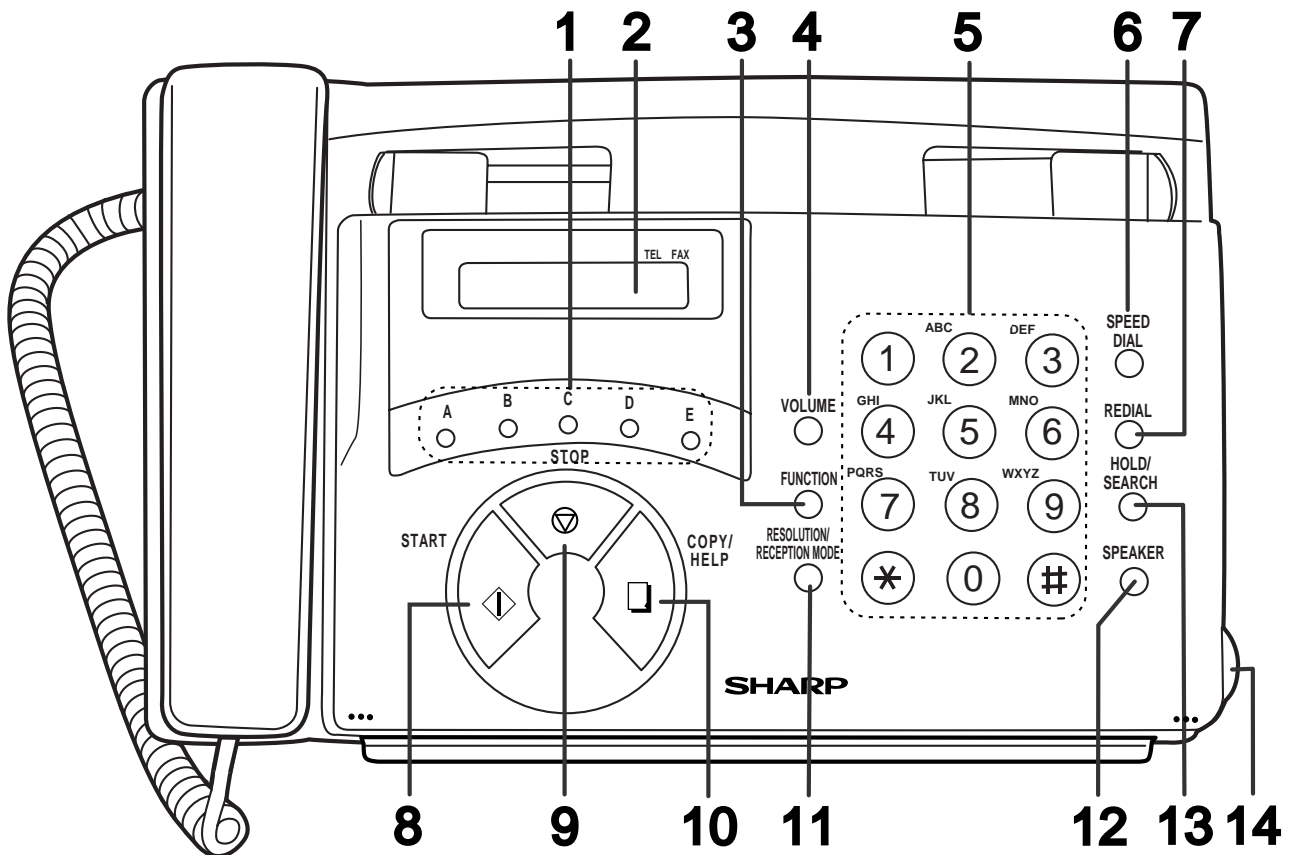

1. Rapid Dial keys

Press one of these keys to dial a fax or voice number automatically.

2. Display

This displays messages and prompts during operation and programming.

3. FUNCTION key

Press this key to select various special functions.

4. VOLUME keys

Press these keys to adjust the volume of the speaker when the **SPEAKER** key has been pressed, the volume of the handset when the handset is lifted, or the volume of the ringer at all other times.

5. Number keys

Use these keys to dial numbers, and enter numbers and letters when storing auto-dial numbers.

6. SPEED DIAL key

Press this key to dial a fax or voice number using an abbreviated 2-digit Speed Dial number.

7. REDIAL key

Press this key to automatically redial the last number dialed.

8. START key

Press this key to begin transmission when using Speed Dialing, Direct Keypad Dialing, or Normal Dialing.

9. STOP key

Press this key to cancel operation before it is completed.

10. COPY/HELP key

When a document is in the feeder, press this key to make a copy of a document. At any other time, press this key to print out the Help List, a quick reference guide to the operation of your fax machine.

11. RESOLUTION/RECEPTION MODE key

When a document is in the feeder, press this key to adjust the resolution for faxing or copying. At any other time, press this key to select the reception mode (an arrow in the display will point to the currently selected reception mode).

12. SPEAKER key

Press this key to listen the line and fax tones through the speaker when faxing a document.

Note: **This is not a speakerphone.** You must pick up the handset to talk with the other party.

13. HOLD/SEARCH key

Press this key to search for an auto-dial number, or, during a phone conversation, press this key to put the other party on hold.

14. Panel release

Grasp this finger hold and pull toward you to open the operation panel.

[3] Transmittable documents

1. Document Sizes

Normal size	width	5.8" – 8.5" (148 – 216 mm)
	length	5.5" – 11" (140 – 279 mm)

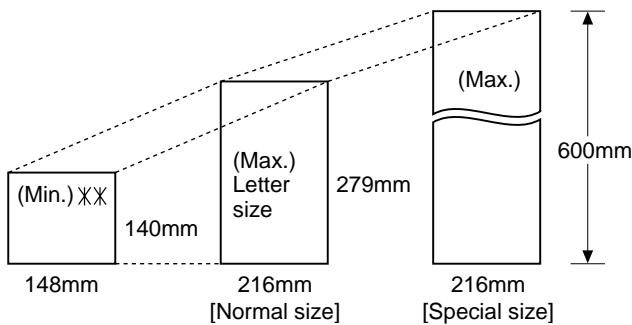

XX Use document carrier sheet for smaller documents.

* With special sizes, only one sheet can be fed into the machine at a time. Insert next page into feeder as current page is being scanned.

2. Paper Thickness & Weight

	4x6 series (788mm x 1091mm x 1000mm sheets)		Square meter series	
	Minimum	Maximum	Minimum	Maximum
Feeder capacity	5 sheets, max.			
Paper weight	45kg	69.2kg	52g/m ²	80g/m ²
Paper thickness (ref.)	0.06mm	0.09mm	0.06mm	0.09mm
Paper size	148mm x 140mm ~ A4 (210mm x 297mm), Letter (216mm x 279mm)			

3. Document Types

- Normal paper
Documents handwritten in pencil (No. 2 lead or softer), fountain pen, ball-point pen, or felt-tipped pen can be transmitted.
Documents of normal contrast duplicated by a copying machine can also be transmitted.
- Diazo copy (blue print)
Diazo copy documents of a normal contrast may be transmitted.
- Carbon copy
A carbon copy may be transmitted if its contrast is normal.

4. Cautions on Transmitting Documents

- Documents written in yellow, greenish yellow, or light blue ink cannot be transmitted.
- Ink, glue, and correcting fluid on documents must be dry before the documents can be transmitted.
- All clips, staples and pins must be removed from documents before transmission.
- Patched (taped) documents should be copied first on a copier and then the copies used for transmission.
- All documents should be fanned before insertion into the feeder to prevent possible double feeds.

5. Automatic Document Feeder Capacity

Number of pages that can be placed into the feeder at anytime is as follows:

Normal size: max. ADF 5 sheets

Special size: single sheet only (manual feed)

- NOTES:
- When you need to send or copy more pages than the feeder limit, place additional pages in feeder when last page in feeder is being scanned.
 - Place additional pages carefully and gently in feeder. If force is used, double-feeding or a document jam may result.

6. Readable Width & Length

The readable width and length of a document are slightly smaller than the actual document size.

Note that characters or graphics outside the effective document scanning range will not be read.

- **Readable width**
8.3" (210mm), max.

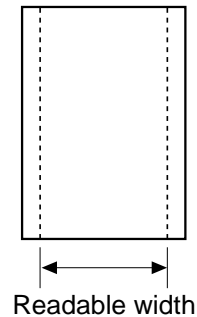

- **Readable length**

This is the length of the document sent minus 0.2" (5mm) from the top and bottom edges.

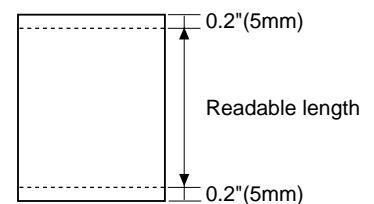

7. Use of Document Carrier Sheet

A document carrier sheet must be used for the following documents.

- Those with tears.
- Those smaller than size 5.8" (W) x 5.5" (L) (148mm (W) x 140mm (L)).
- Carbon-backed documents

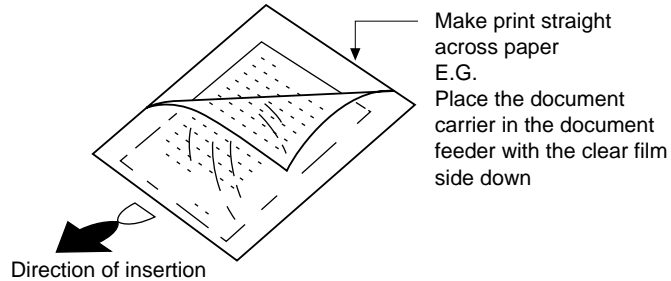

NOTE: To transmit a carbon-backed document, insert a white sheet of paper between the carbon back of the document and the document carrier.

- Those containing an easily separable writing substance (e.g., tracing paper written on with a soft, heavy lead pencil).

NOTES: • When using the document carrier, carefully read the instructions written on the back.

- If the document carrier is dirty, clean it with a soft, moist cloth, and then dry it before using for transmission.
- Do not place more than one document in the carrier at a time.

[4] Installation

1. Site selection

Take the following points into consideration when selecting a site for this model.

ENVIRONMENT

- The machine must be installed on a level surface.
- Keep the machine away from air conditioners, heaters, direct sunlight, and dust.
- Provide easy access to the front, back, and sides of the machine. In particular, keep the area in front of the machine clear, or the original document may jam as it comes out after scanning.
- The temperature should be between 5° and 35°C.
- The humidity should be between 30% and 85% (without condensation).

ELECTRICITY

AC 120V, 60Hz, grounded (3-prong) AC outlet is required.

Caution!

- Connection to a power source other than that specified will cause damage to the equipment and is not covered under the warranty.
- If your area experiences a high incidence of lightning or power surges, we recommend that you install a surge protector for the power and telephone lines. Surge protectors can be purchased at most telephone specialty stores.

If the machine is moved from a cold to a warm place...

Condensation may form on the reading glass if the machine is moved from a cold to a warm place. This will prevent proper scanning of documents for transmission. Turn on the power and wait approximately 2 hours before using machine.

TELEPHONE JACK

A standard RJ11C telephone jack must be located near the machine. This is the telephone jack commonly used in most homes and offices.

- Plugging the fax machine into a jack which is not an RJ11C jack may result in damage to the machine or your telephone system. If you do not know what kind of jack you have, or need to have one installed, contact the telephone company.

2. Assembly and connections

① Plug the power cord into a 120 V, 60 Hz, grounded (3-prong) AC outlet.

- **Caution:** Do not plug the power cord into any other kind of outlet. This will damage the machine and is not covered under the warranty.
- The machine does not have a power on/off switch, so the power is turned on and off by simply plugging in or unplugging the power cord.

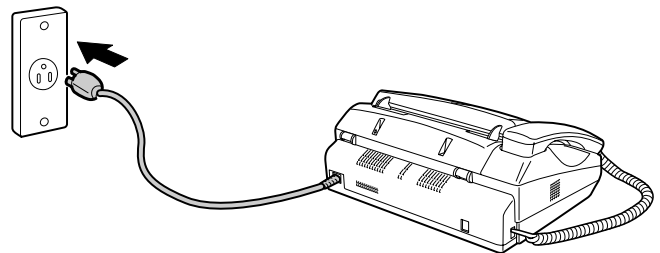

② Connect the handset as shown and place it on the handset rest.

- The ends of the handset cord are identical, so they will go into either jack.

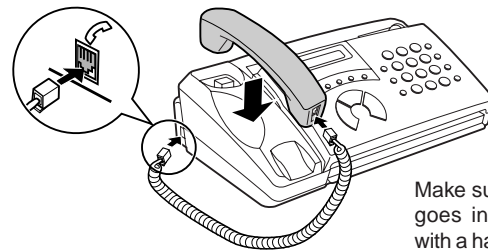

Make sure the handset cord goes into the jack marked with a handset symbol on the side of the machine!

Use the handset to make ordinary phone calls, or to transmit and receive faxes manually.

③ Attach the original document support as shown below.

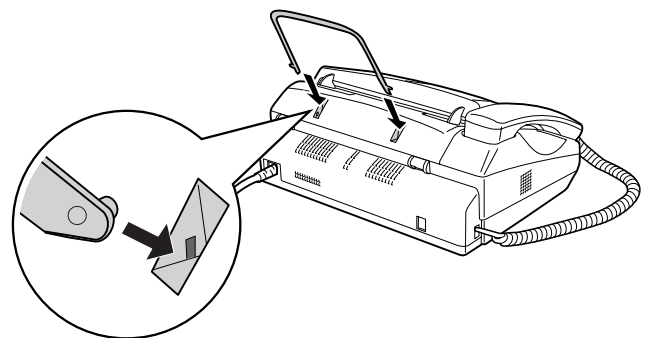

- ④ Insert one end of the line cord into the jack on the back of the machine marked **TEL. LINE**. Insert the other end into a standard (RJ11C) single-line wall telephone jack.

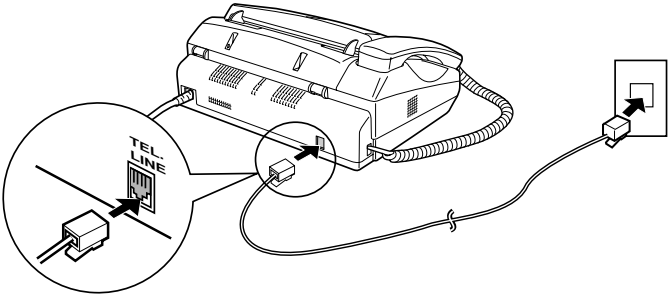

Note: The fax machine is set for touch-tone dialing. If you are on a pulse dial (rotary) line, you must set the fax machine for pulse dialing. Press the keys on the operation panel as follows:

1. Press these keys:

The display will show:

DIAL MODE

FUNCTION



2. Press **1** to select tone (touch-tone) dialing, or **2** to select pulse (rotary) dialing.

STONE PULSE



or



3. Press the **STOP** key to return to the date and time display.

STOP



3. Removing the packing paper

- ① Grasp the finger hold and pull up to open the operation panel.

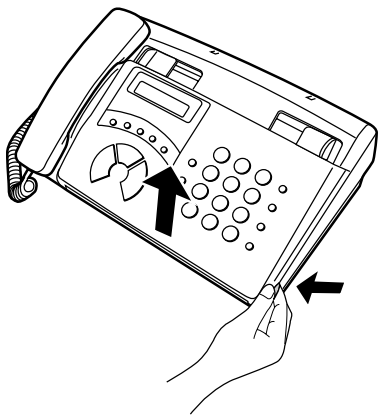

- ② Flip up the front paper guide.

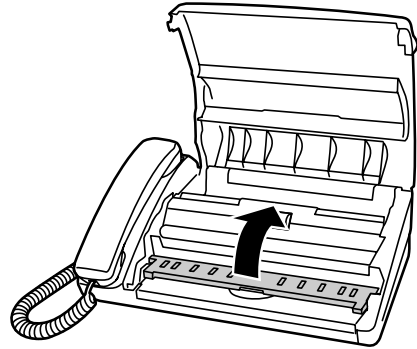

- ③ Remove the packing paper.

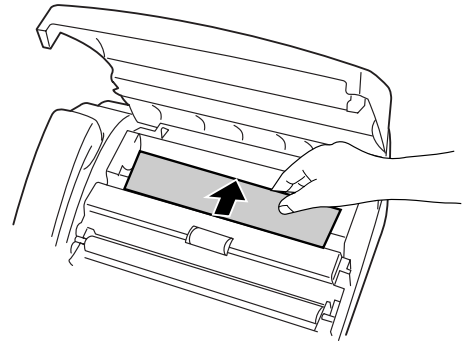

- ④ Flip down the front paper guide and then close the operation panel.

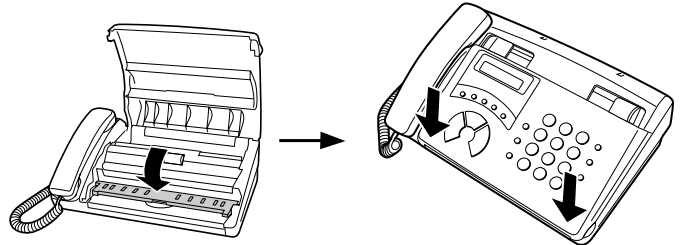

4. Loading the thermal paper (FO-20PRw)

- Your fax machine prints incoming faxes on a special kind of paper called thermal paper.
- The fax machine's print head creates text and images by applying heat to the thermal paper.

① Grasp the finger hold as shown and pull up to open the operation panel.

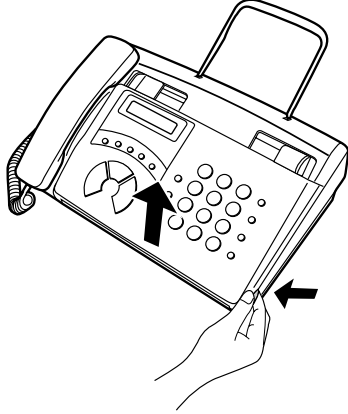

② Flip up the front paper guide.

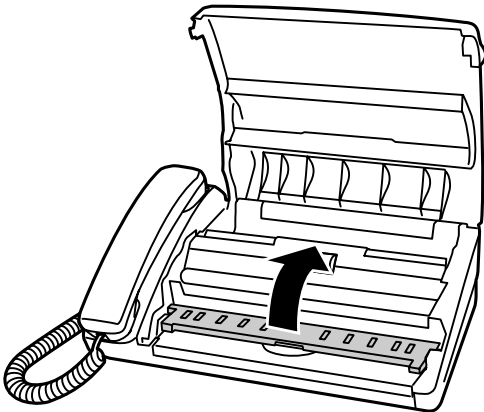

③ Unwrap the roll of thermal paper and place it in the compartment.

- ◆ **Important:** The roll must be placed so the leading edge of the paper unrolls as shown. (The paper is only coated on one side for printing. If the roll is placed backwards, the paper will come out blank after printing.)

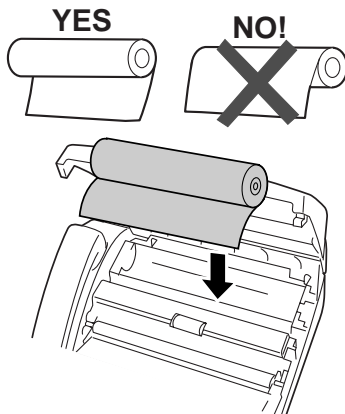

④ Insert the leading edge of the paper into the slot as shown. Continue to push the paper through the slot until it comes out the opening in the front of the machine.

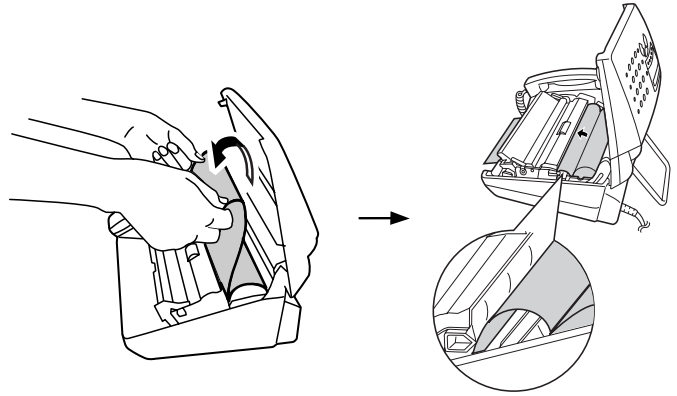

⑤ Make sure the paper comes out straight, and then flip down the paper guide.

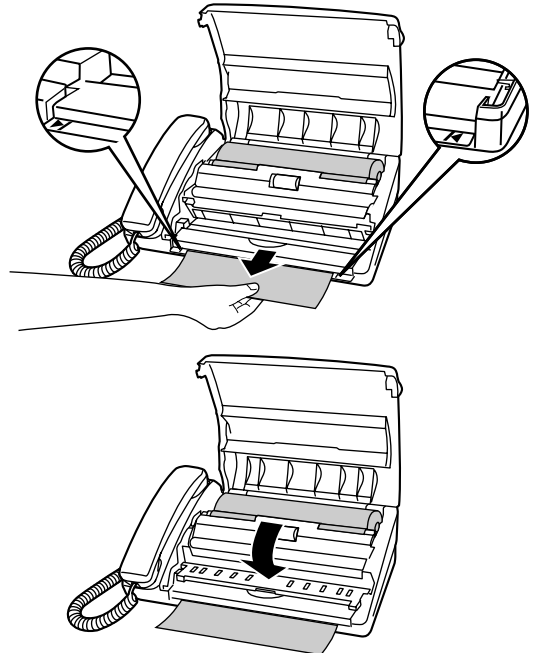

⑥ Close the operation panel, making sure it clicks into place.

- A short length of the paper will feed out. Grasp the paper by the edge and pull upward to tear it off.

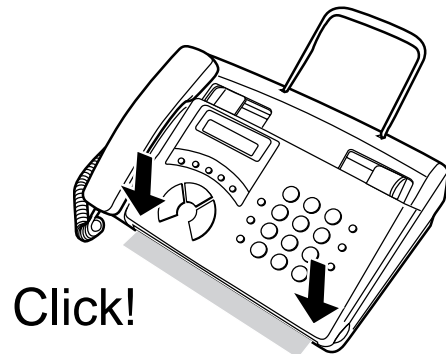

5. Clearing a jammed document

If the original document doesn't feed properly during transmission or copying, or DOCUMENT JAMMED appears in the display, first try pressing the **START** key. If the document doesn't feed out, open the operation panel and remove it.

Important:

Do not try to remove a document without first releasing it as explained below.

This may damage the feeder mechanism.

- ① Grasp the finger hold and pull up to open the operation panel.

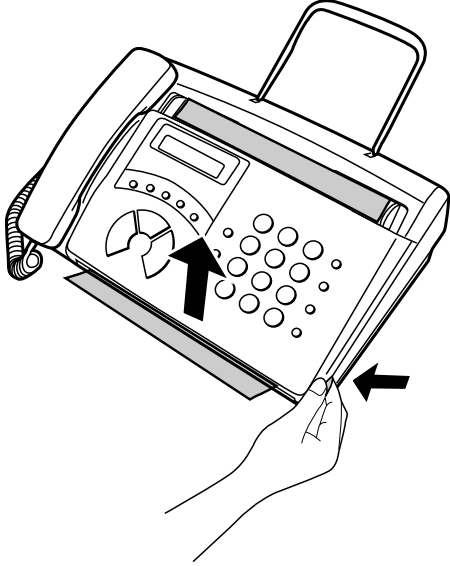

- ② Flip up the green levers on each side of the white roller.

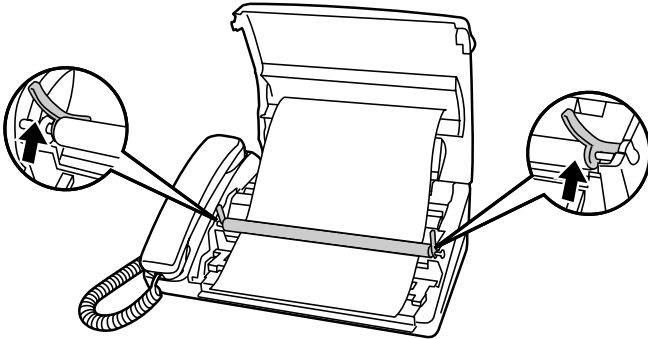

- ③ Remove the document.

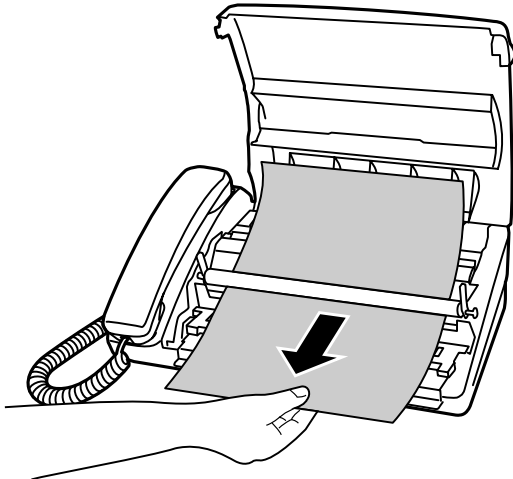

- ④ Flip down the green levers on each side of the white roller.

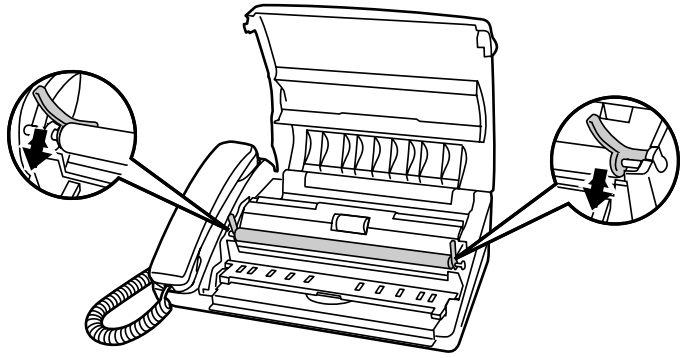

- ⑤ Close the operation panel, making sure it clicks into place.

- Press down on both front corners of the panel to make sure it clicks into place.

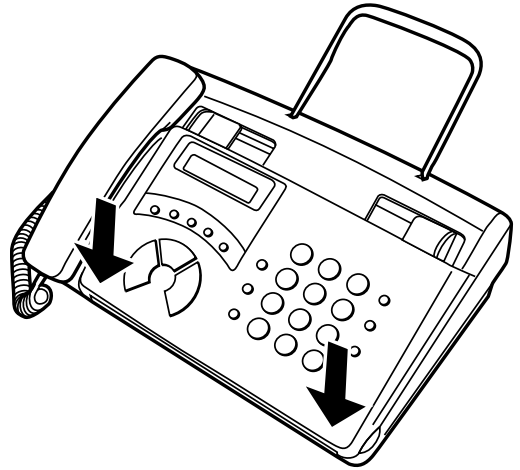

6. Clearing jammed paper

If the thermal paper jams, PAPER JAMMED will appear in the display. Follow the steps below to clear the jam.

- ① Grasp the finger hold and pull up to open the operation panel.

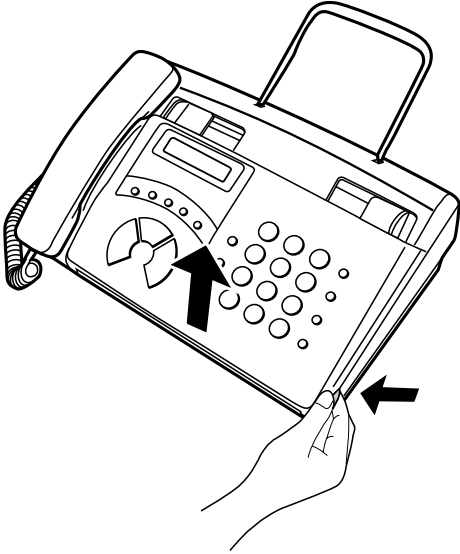

- ② Flip up the front paper guide.

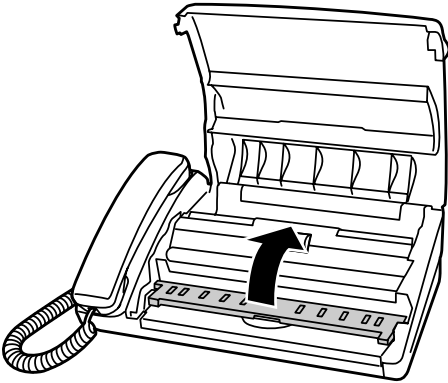

- ③ Remove the paper roll.

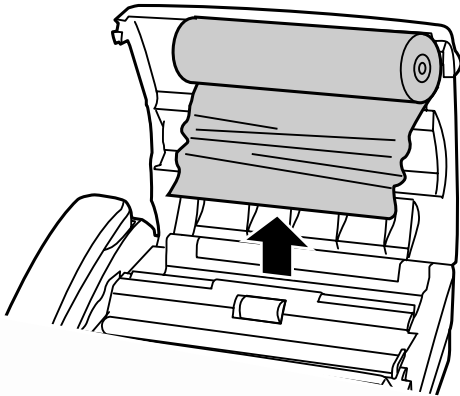

- ④ Cut off the wrinkled part of the paper.

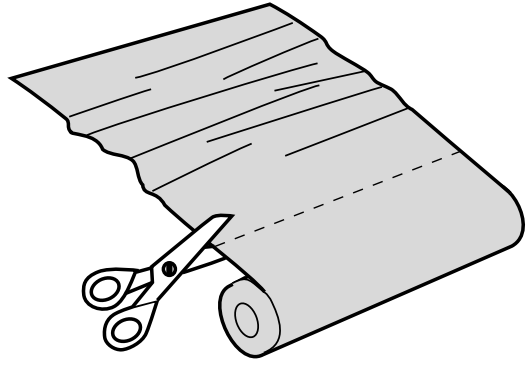

- ⑤ Reload the paper.

- Jammed paper is often caused by improper loading. Be sure to carefully follow the instructions for paper loading given in Loading the Thermal Paper.

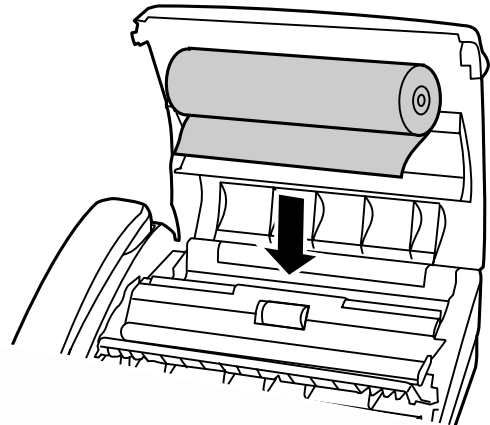

[5] Quick reference guide

ENTERING YOUR NAME AND NUMBER

- Press: **3** **#** **#** **#**
Display shows: **OWN NUMBER SET**
- Press:
- Enter your fax number (max. of 20 digits) by pressing the number keys.
 - To insert a space between digits, press the # key.
 - If you make a mistake, press the **SPEED DIAL** key to backspace and clear the mistake.
- Press:
- Enter your name by pressing the appropriate number keys as shown below.
 - To enter two letters in succession that require the same key, press the **SPEAKER** key after entering the first letter.

SPACE =	J =	T =
A =	K =	U =
B =	L =	V =
C =	M =	W =
D =	N =	X =
E =	O =	Y =
F =	P =	Z =
G =	Q =	
H =	R =	
I =	S =	

- To change case, press the **REDIAL** key.
Press # or ✕ to scroll through symbols and special characters.
- When finished, press:

SETTING THE DATE AND TIME

- Press: **3** **#** **#** **#**
Display shows: **DATE & TIME SET**
- Press:
- Enter two digits for the Month (01 through 12).
- Enter two digits for the Day (01 through 31).
- Enter four digits for the Year (Ex: 1999).
- Enter two digits for the Hour (01 through 12).
- Enter two digits for the Minute (00 through 59).
- Press the ✕ key for A.M. or the # key for P.M.
- When finished, press:

STORING AND CLEARING AUTO DIAL NUMBERS

- Press: **3** **#**
Display shows: **FAX/TEL # MODE**
- Press **1** to store a number or **2** to clear a number.
- Enter a 2-digit Speed Dial number (from 01 to 05 for Rapid Key Dialing, or 06 to 40 for Speed Dialing) (If you are clearing a number, go to Step 7.)
- Enter the full telephone/fax number.
- Press:
- Enter the name of the location by pressing number keys (Refer to the letter entry table in *ENTERING YOUR NAME AND NUMBER*.)
- Press:

SENDING FAXES

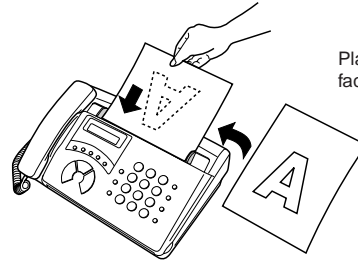

Place your document (up to 5 pages) face down in the document feeder.

Normal Dialing

- Lift the handset or press
- Dial the fax number.
- Wait for the reception tone (if a person answers, ask them to press their Start key).
- Press:

Rapid Key Dialing

Press the appropriate Rapid Key. Transmission will begin automatically.

Speed Dialing

- Press:
- Enter 2-digit Speed Dial number.
- Press:

RECEIVING FAXES

Press the **RESOLUTION/RECEPTION MODE** key until the arrow in the display points to the desired reception mode (make sure the document feeder is empty).

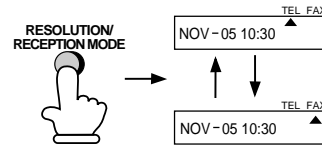

FAX mode: The fax machine automatically answers on four rings and receives the incoming document.

TEL mode:

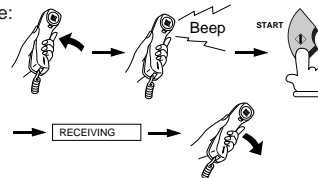

SETTING THE DISPLAY LANGUAGE

- Press: **4** **#** **#** **#**
- Press:
- Press the # key or ✕ key until the desired language appears in the display.
- Press:
- Press:

[6] Quick setup guide (UX-44U only)

SHARP® UX-44 FAX

QUICK SETUP GUIDE

Note: To enter your name and fax number and set the date and time so that they appear on the automatic cover sheet, see pages 19 - 25 of your operation manual.

1

Remove the packing paper.

1. Grasp the finger hold and pull up to open the operation panel.
2. Flip up the front paper guide.



3. Remove the packing paper.
4. Flip down the front paper guide and close the operation panel.

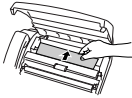

2

Connect the handset and place it on the handset rest.

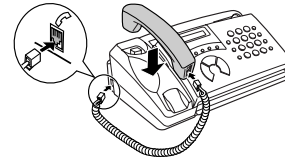

Note: Make sure that the area in front of the machine is clear.

3

Plug the power cord into a 120 v, 60Hz, grounded AC (3-prong) outlet.

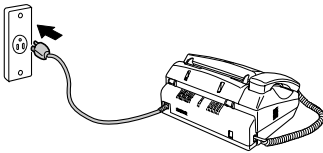

4

Connect the telephone line cord to the **TEL. LINE** jack and a wall telephone jack.

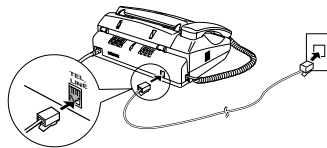

5

Attach the document support.

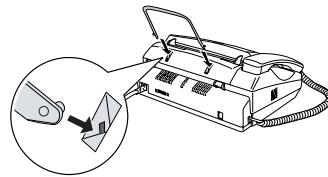

6

Load the thermal paper.

1. Grasp the finger hold and pull up to open the operation panel.
2. Flip up the front paper guide.
3. Unwrap the roll of thermal paper and place it in the compartment.

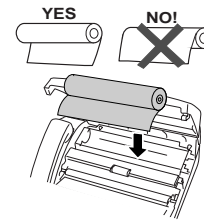
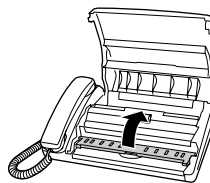

4. Insert the leading edge of the paper into the slot. Push the paper through until it comes out the opening on the front of the machine.

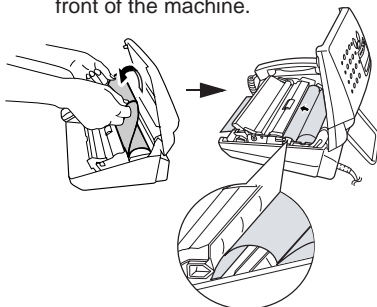

5. Make sure the paper comes out straight, and then flip down the paper guide.

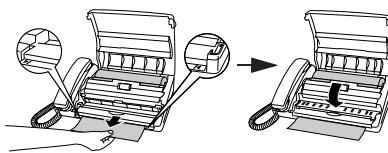

6. Grasp the edge of the paper that feeds out and pull up to tear it off.

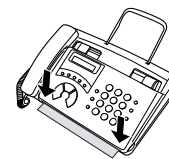

(TCADZ2869XHZZ)

CHAPTER 2. ADJUSTMENTS

[1] Adjustments

General

The following adjustments and settings are provided for this model. Make adjustments and/or setup as necessary.

1. Adjustments

Adjustments of output voltage (FACTORY ONLY)

1. Install the power supply unit in the machine.
2. Set the recording paper and document.
3. When the document is loaded, power is supplied to the output lines. Confirm that outputs are within the limits below.

Output voltage settings

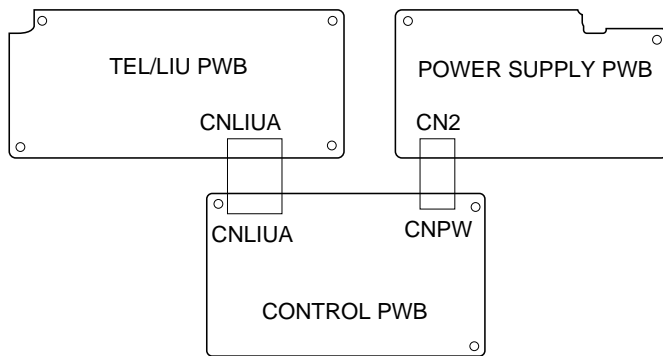

Output	Voltage limits
+5V	4.75V ~ 5.25V
+24V	24.0V ~ 26.0V

Connector No.	CNPW
Pin No.	
1	DG
2	+5V
3	MG
4	MG
5	+24V
6	+24V

2. IC protectors replacement

ICPs (IC Protectors) are installed to protect the motor driver circuit. ICPs protect various ICs and electronic circuits from an overcurrent condition.

The location of ICPs are shown below:

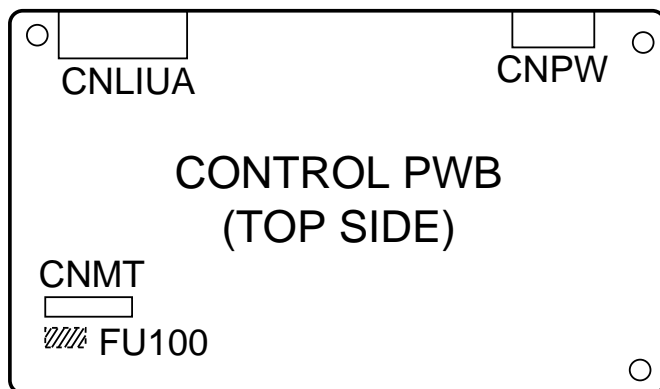

- (1) FU100 (KAB2402) is installed in order to protect IC's from an over-current generated in the motor drive circuit. If FU100 is open, replace it with a new one.

3. Settings

Dial mode selector

DIAL mode (Soft Switch No. SWB4 DATA No. 2)

(step 1) Select "OPTION SETTING".

KEY: **FUNCTION** ④

DISPLAY: **OPTION SETTING** ↔ **PRESS ✕ OR #**

(step 2) Select "DIAL MODE".

KEY: Push **#** until "**DIAL MODE**" is indicated because the number of **#**'s changes by the model.

Cursor
When initially registering, the mode shows 1=TONE. When registering again, the mode which was registered formerly is shown.

DISPLAY: **DIAL MODE** ↔ **1=TONE, 2=PULSE**

(step 3) Select, using "1" or "2".

KEY: ①

DISPLAY: **TONE SELECTED**

KEY: ②

DISPLAY: **PULSE SELECTED**

(step 4) End, using the "STOP" key.

KEY: STOP

4. Volume setting

You can adjust the volume of the speaker, ringer, and handset using the **VOLUME** key.

(1) Speaker

- ① Press the **SPEAKER** key.
- ② Press the **VOLUME** key one or more times to select the desired level.

The display will show:

SPEAKER VOLUME

- ③ Press the **SPEAKER** key once again to turn off the speaker.

(2) Handset

- ① Lift the handset.
- ② Press the **VOLUME** key to select the desired level.

The display will show:

RECEIVER VOLUME

- ③ Replace the handset.

• Note: The handset volume reverts to medium each time you hang up.

(3) Ringer

- ① Press the **VOLUME** key to select the desired volume. (Make sure the **SPEAKER** key has not been pressed and the handset is not lifted.)

The display will show:

RINGER VOLUME

- ② If you want to turn off the ringer, continue to press the **VOLUME** key until **RINGER OFF: OK?** appears in the display, and then press the **START** key.

[2] Diagnostics and service soft switch

1. Operating procedure

(1) Entering the diagnostic mode

Press **FUNC** → **9** → ***** → **8** → **#** → **7**, and the following display will appear.

ROM Ver. FZF0 * After 2 sec: DIAG MODE

FZF0 *

Then press the **START** key and country name selected by country select will appear. Select the desired item with the ***** key or the **#** key or select with the direct key. Enter the mode with the **START** key.

(Diag•specifications)

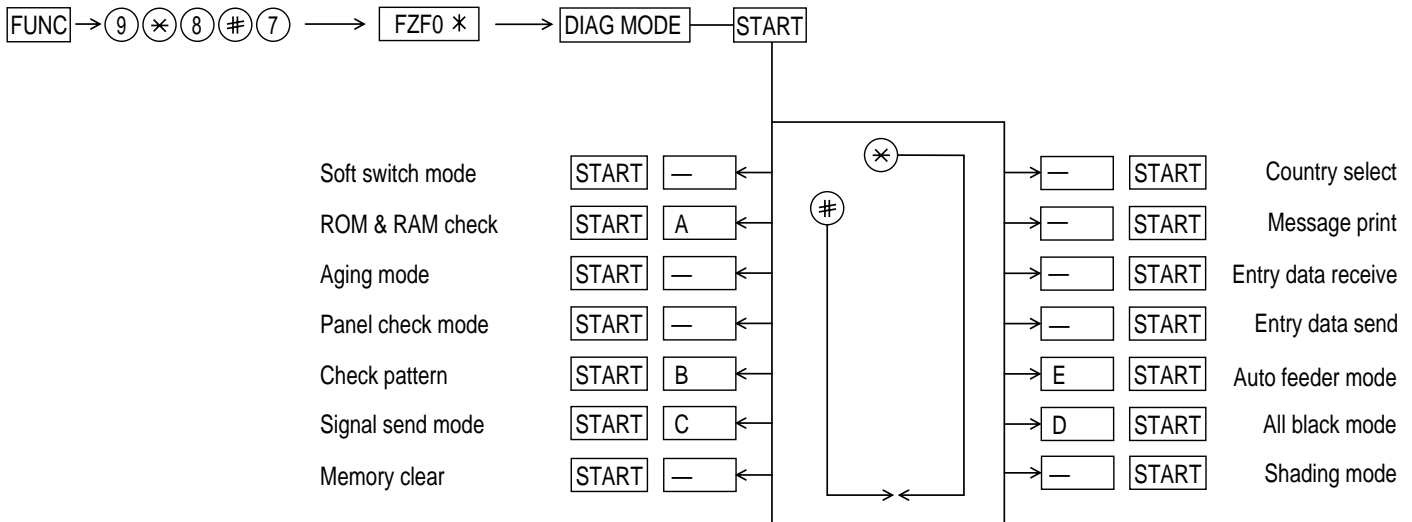

If the diag mode cannot be set, repeat the diag mode operation, performing the following operation.

After the power is turned on and "WAIT A MOMENT" is indicated, press the **STOP** key.

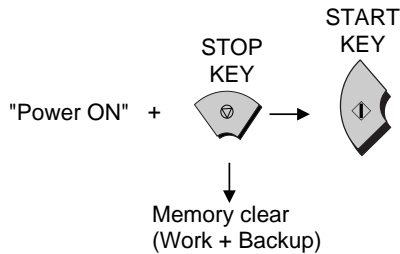

If the **STOP** key is held down, "MEMORY CLEAR?" appears.

2. Diagnostic items

ITEM No.	DIRECT key	Contents	Function
1	—	SOFT SWITCH MODE	Soft switches are displayed and changed. List can be output.
2	A	ROM & RAM CHECK	ROM is sum-checked, and RAM is matched. Result list is output.
3	—	AGING MODE	10 sheets of check patterns are outputted every 5 minutes per sheet.
4	—	PANEL CKECK MODE	Panel keys are tested. Result list is output.
5	B	CHECK PATTERN	2 sheets of check patterns are output.
6	C	SIGNAL SEND MODE	Various signals of FAX communication are output.
7	—	MEMORY CLEAR	Back-up memory is cleared, and is set at delivery.
8	—	SHADING MODE	Shading compensation is performed in this mode.
9	D	ALL BLACK PRINT	To check the print head, whole dots are printed over the interval of 2 m.
10	E	AUTO FEEDER MODE	Insertion and discharge of document are tested.
11	—	ENTRY DATA SEND	Registered content is sent.
12	—	ENTRY DATA RECEIVE	Registered content is received, and its list is output.
13	—	MESSAGE PRINT	The display message of each language is printed out together with the English equivalent.
14	—	COUNTRY SELECT	The software parameter that it agreed in each country name is set up.

3. Diagnostic items description

3. 1. Soft switch mode

The soft switches are provided so that each operation mode can be set by using the operation panel.

In this mode, these switches can be checked and set.

The contents of these switches are backed up.

The available soft switches are SW-A1 to SW-K1.

The content of soft switches is shown in page 2-5 to 2-17.

The contents are set to factory default settings.

3. 2. ROM & RAM check

ROM executes the sum check, and RAM executes the matching test. The result will be notified with the number of short sounds of the buzzer as well as by printing the ROM & RAM check list.

Number of short sounds of buzzer 0 → No error
1 → ROM error
2 → RAM error (32Kbyte)

3. 3. Aging mode

If any document is first present, copying will be executed sheet by sheet. If no document is present, the check pattern will be printed sheet by sheet. This operation will be executed at a rate of one sheet per 5 minutes, and will be ended at a total of 10 sheets.

3. 4. Panel check mode

This mode is used to check whether each key operates properly or not. Press the key on the operation panel, and the key will be displayed on the display. Therefore, press all keys. At this time, finally press the STOP key.

When the STOP key is pressed, the keys which are not judged as "pressed" will be printed on the result list.

- LED part of the contact image sensor (CIS) is kept on during the term from when "START" of the panel test mode to end with the STOP key.

3. 5. Check pattern

This mode is used to check the status of print head. Two sheets of check pattern are printed. The following information of check pattern is printed.

- ① Vertical stripes (alternate white and black lines) Approx. 35 mm
- ② Full black Approx. 70 mm
- ③ Full white Approx. 35 mm

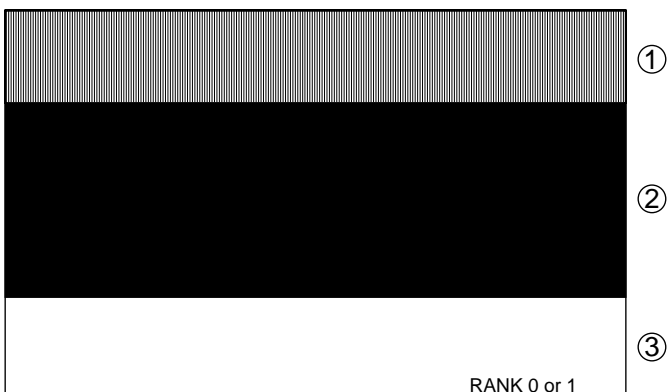

Note:
There is a selection RANK 0 or 1 depending on resistance value of the thermal head. RANK 0 or RANK 1 is printed at the tail of check pattern to identify.

3. 6. Signal send mode

This mode is used to send various signals to the circuit during FAX communication. Every push of START key sends a signal in the following sequence. Moreover, the signal sound is also output to the speaker when the line monitor of the soft switch is on.

- [1] No signal (CML signal turned on)
- [2] 9600bps
- [3] 7200bps
- [4] 4800bps
- [5] 2400bps
- [6] 300bps (FLAG)
- [7] 2100Hz (CED)
- [8] 1100Hz (CNG)
- [9] Pseudo Ring (models with auto TEL/FAX changeover function)
- [10] END

3. 7. Memory clear

This mode is used to clear the backup memory and to reset to the factory default settings.

The content of each setting will be cleared.

Note: Be sure to execute the memory clear mode whenever you change the country select setting. The default settings of the soft switches vary according to the destinations. Therefore, if you do not execute the memory clear after changing the country select setting, some functions may not work.

3. 8. Shading mode

The mode is used for the shooting compensation. For reading, set up the special original paper.

The shooting compensation memorizes the reference data of white and black for reading.

Moreover, the memorized data is not erased even if memory clear mode is executed.

3. 9. All black print

This mode is used to check the state of the printing head and intentionally overheat it. Whole dots are printed over the interval of 2 m. If it is overheated or the printing sheet is jammed, press STOP key for the end.

3. 10. Auto feeder mode

In this mode, a document is inserted and discharged to check the auto feed function.

After this mode is started, set a document, and the document feed will be automatically tested.

3. 11. Entry data send

This mode is used to send the registered data to the other machine and to make the other machine copy the registered content. Before sending in this mode, it is necessary to set the other machine at the entry data receive mode.

The contents to be sent are as follows (the machine prints each list after the transmission has completed):

- 1. Telephone list data
- 2. Sender (cover sheet) register data
- 3. Optional setting content
- 4. Soft switch content
- 5. Junk fax number list
- 6. Country setting content

3. 12. Entry data receive

This mode is used to receive the registered data from the other machine and to make your machine register the received data. Before receiving in this mode, it is necessary to set the other machine in the entry data send mode.

After receiving is completed, the machine prints the following lists:

1. Telephone list data
2. Soft switch list
3. Junk fax number list

3. 13. Message print

In this mode, all the message data, which are used for displaying indication and list print, are printed as a contrast table of the selected language and English.

4. How to make soft switch setting

To enter the soft switch mode, press the following key entries in sequence.

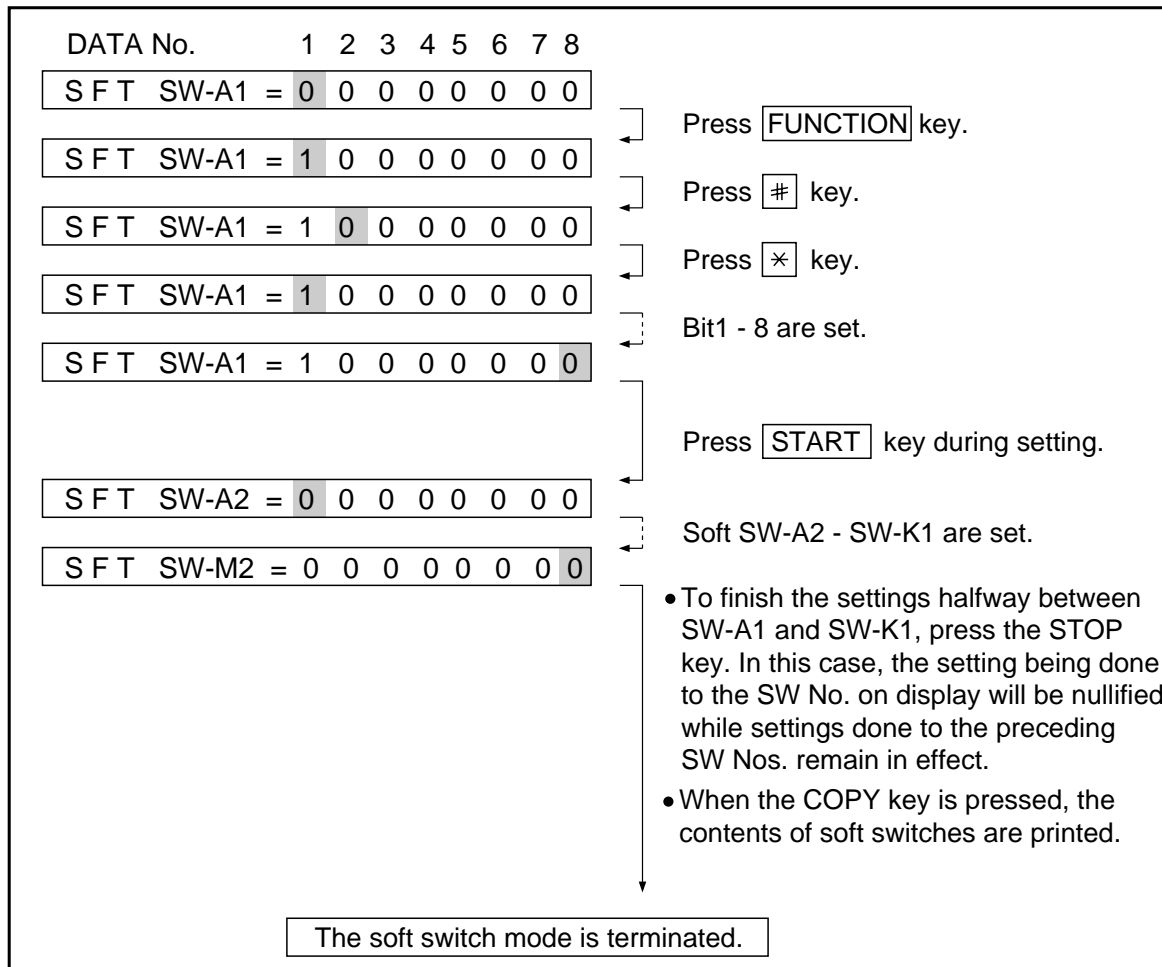
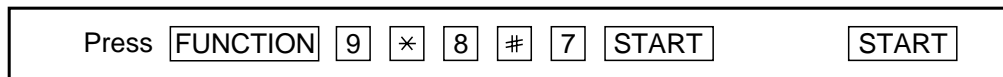

3. 14. Country select

This mode is used to set line connecting parameters which correspond to each destination.

When the country select mode is selected, and then the START key is pressed, the destination (country name) currently set will be displayed. By pressing the # or * key, selectable destinations (country names) are displayed. When the destination (country name) you want to choose is displayed, press the START key. Each parameter will be stored in RAM.

Destinations (Country names) you can select are as follows:

COUNTRY NAME	
U. S. A	(U)
CANADA	(C)
LATIN AMERICA (LA/LU)	
ARGENTINA	(AR)

Note: Be sure to execute the memory clear mode whenever you change the country select setting. The default settings of the soft switches vary according to the destinations. Therefore, if you do not execute the memory clear after changing the country select setting, some functions may not work.

Do not set a country select setting which is different from that of the destination of the machine. Some functions will not work because the function and the PWB specifications are different.

5. Soft switch description

• Soft switch

SW NO.	DATA NO.	ITEM	Switch setting and function				Initial setting	Remarks	
			1		0				
SW I A1	1	Protect from echo	No		Yes		0		
	2	Forced 4800bps reception	Yes		No		0		
	3	Footer Print	Yes		No		0		
	4	Length limitation of copy/send/receive	No limit		Copy/Send:60cm Receive:1.5m		0		
	5	CSI transmission	Not transmitted		Transmitted		0		
	6	DIS receive acknowledgement during G3 transmission	Twice		NSF:Once DIS:Twice		0		
	7	Non modulated carrier for V29 transmission mode	Yes		No		0		
	8	Reserved					1		
SW I A2	1 2 3 4	Modem speed			V.29		V.27 ter		0 0 0 1
					9600bps	7200bps	4800bps	2400bps	
			No. 1	0	0	0	0		
			No. 2	0	0	0	0		
			No. 3	0	1	1	0		
			No. 4	1	1	0	0		
	5	Reserved					1		
	6	H2 mode	No		Yes		0		
7	Communication error treatment in RTN sending mode(Reception)	No communication error		Communication error		0			
8	CNG transmission	No		Yes		0			
SW I A3	1 2	CED tone signal interval			1000ms	750ms	500ms	75ms	0 0
			No. 1	1	1	0	0		
			No. 2	1	0	1	0		
	3	MR Coding	No		Yes		0		
	4	Reserved					0		
	5	Reserved					0		
	6	Reserved					0		
	7	Reserved					0		
8	Reserved					0			
SW I A4	1	Signal Transmission level (0~-31 dBm setting by 1dBm step)	Binary input				0		
	2		No. = 16 8 4 2 1				1		
	3		1 2 3 4 5				0		
	4		0 1 0 1 0				1		
5					0				
6	Protocol monitor(Error print)	Printed at com. error		Not printed		0			
7	Protocol monitor	Yes		No		0			
8	Line monitor	Yes		No		0			
SW I A5	1 2	Digital equalization setting(Reception)			7.2km		0km		1 1
			No. 1	1	0				
			No. 2	1	0				
	3 4	Digital equalization setting(Transmitter)			7.2km		0km		0 0
			No. 3	1	0				
			No. 4	1	0				
	5 6	Digital equalization setting(Reception for Caller ID)			7.2km		0km		0 0
			No. 5	1	0				
		No. 6	1	0					
7	Error criterion	10 ~ 20 %		5 ~ 10 %		0			
8	Anti junk fax check	Yes		No		1			

SW NO.	DATA NO.	ITEM	Switch setting and function					Initial setting	Remarks
			1		0				
SW I A6	1	Auto gain control(MODEM)	Enable		Disable			1	
	2	End Buzzer	Yes		No			1	
	3	Disconnect the line when DIS is received in RX mode	No		Yes			1	
	4	Equalizer freeze control(MODEM)	On		Off			0	
	5	Equalizer freeze control 7200 bps only	No		Yes			0	
	6	CNG transmission in manual TX mode	Yes		No			1	
	7	Initial compression scheme for sharp fax in TX mode	MR mode		H2 mode			0	
	8	Modem speed automatic down when RX level is under -40dBm	Yes		No			0	
SW I A7	1	EOL detect timer		5 seconds	13 seconds	20 seconds	25 seconds	0	
	2		No. 1	0	0	1	1		
	3		No. 2	0	1	0	1		
	4	Reserved						0	
	5	Reserved						0	
	6	Reserved						0	
	7	Reserved						0	
	8	Reserved						0	
SW I B1	1	Hold key	Enable		Disable			1	
	2	Auto dial fax transmission by REDIAL key	Yes		No			0	
	3	Reserved						0	
	4	Recall interval (0~15.5min setting by 0.5min step)	Binary input					0	
	5		No. =	16	8	4	2	1	
	6			4	5	6	7	8	
	7			0	1	0	1	0	
	8							0	
SW I B2	1	Recall times(0~15times setting)	Binary input					0	
	2		No. =	8	4	2	1		
	3			1	2	3	4		
	4			0	0	1	0		
	5	Dial tone detection(Before auto dial)	No		Yes			1	
	6	Reserved						0	
	7	Busy tone detection(After auto dial)	No		Yes			0	
	8	Busy tone detection pulse number (After auto dial)	4 pulses		2 pulses			0	
SW I B3	1	Waiting time after dialing		45 seconds	55 seconds	90 seconds	140 seconds	0	
	2		No. 1	0	0	1	1		
	3		No. 2	0	1	0	1		
	4	Reserved						0	
	5	Reserved						0	
	6	Reserved						0	
	7	Reserved						0	
	8	Reserved						0	
SW I B4	1	Dial pausing(sec/pause)	4 sec		2 sec			0	
	2	Dial mode	Tone		Pulse			1	OPTION
	3	Pulse → Tone change function by ✕ key	Enable		Disable			0	
	4	Dial pulse make/break ratio(%)	40/60		33/67			1	
	5	Auto dial mode Delay timer of before line connect		0 second	1.5 seconds	3.0 seconds	4.5 seconds	0	
	6		No. 5	0	0	1	1		
	7		No. 6	0	1	0	1		
	8	Reserved						0	

SW NO.	DATA NO.	ITEM	Switch setting and function										Initial setting	Remarks
			1					0						
SW B5	1 2 3	Auto dial mode Delay timer of after line connect		1.7s	2.0s	2.5s	3.0s	3.6s	4.0s	5.5s	7.0s	0 0 0		
			No.1	0	0	0	0	1	1	1	1			
			No.2	0	0	1	1	0	0	1	1			
		No.3	0	1	0	1	0	1	0	1				
	4	Fax signal detection after telephone mode dial	Yes					No					0	
	5	Recalling fixed only one time when dialing was unsuccessful without detecting busy tone signal	Yes					No					1	
	6	Reserved											0	
	7	Reserved											0	
8	Reserved											0		
SW B6	1 2 3 4 5	DTMF signal transmission level (Low frequency 0~15.5dBm setting by 0.5dBm step)	Binary input										0	
			No. = 16 8 4 2 1										1	
			1 2 3 4 5										1	
			0 1 1 0 0										0	
													0	
	6	Reserved											0	
	7	Reserved											0	
	8	Reserved											0	
SW B7	1 2 3 4 5	DTMF signal transmission level (High frequency 0~15.5dBm setting by 0.5dBm step)	Binary input										0	
			No. = 16 8 4 2 1										1	
			1 2 3 4 5										0	
			0 1 0 0 1										0	
													1	
	6	Reserved											0	
	7	Reserved											0	
	8	Reserved											0	
SW C1	1 2	Reading Slice(Binary)			Factory setting	Dark	Light	Daker in dark	0 0					
			No.1	0	0	1	1							
		No.2	0	1	0	1								
	3 4	Reading Slice(Half tone)			Factory setting	Dark	Light	Daker in dark	0 0					
			No.3	0	0	1	1							
		No.4	0	1	0	1								
	5	Line density selection	Fine					Standard					0	
	6	Reserved											0	
7	MTF correction in half tone mode	No					Yes					0		
8	Reserved											0		
SW D1	1 2 3 4	Number of rings for auto receive (0~15rings setting)	Binary input										0	OPTION
			No. = 8 4 2 1										1	
			1 2 3 4										0	
			0 1 0 0										0	
	5	Automatic swiching manual to auto receive function	Yes					No					0	
	6 7	CI detect frequency			As PTT	11.5Hz	13.0Hz	20.0Hz	0 0					
			No.6	0	0	1	1							
		No.7	0	1	0	1								
8	Reserved											0		

SW NO.	DATA NO.	ITEM	Switch setting and function						Initial setting	Remarks		
			1			0						
SW D2	1 2 3	Distinctive ringing setting			USA/ Canada	USA/ Canada	USA/ Canada	USA/ Canada	Canada	Canada	0 0 0	OPTION
				OFF	Std.	Pat.1	Pat.2	Pat.3	Pat.4	Pat.5		
			No. 1	0	0	0	0	1	1	1		
	No. 2	0	0	1	1	0	0	1				
	No. 3	0	1	0	1	0	1	0				
	4	Reserved									0	
	5	Reserved									0	
	6	Caller ID function	Yes			No					0	OPTION
7	Reserved									0		
8	Reserved									0		
SW D3	1	CI off detection timer	Binary input						0			
	2	(0~1550ms setting by 50ms step)	No. =	16	8	4	2	1		1		
	3			1	2	3	4	5		1		
	4			0	1	1	1	0		1		
	5									0		
	6	Reserved								0		
	7	Reserved								0		
	8	Reserved								0		
SW D4	1	DTMF type Caller ID RX level	Binary input						1			
	2	(0~44dBm setting by 1dBm step)	No. =	32	16	8	4	2	1	0		
	3			1	2	3	4	5	6	1		
	4			1	0	1	1	0	0	1		
	5									0		
	6									0		
	7	Reserved								0		
	8	Reserved								0		
SW E1	1	Reserved								0		
	2	Reserved								0		
	3	Reserved								0		
	4	Reserved								0		
	5	Reserved								0		
	6	Reserved								0		
	7	Reserved								0		
	8	Reserved								0		
SW E2	1	Reserved								0		
	2	Reserved								0		
	3	Reserved								0		
	4	Reserved								0		
	5	Reserved								0		
	6	Reserved								0		
	7	Reserved								0		
	8	Reserved								0		
SW E3	1	Reserved								0		
	2	Reserved								0		
	3	Reserved								0		
	4	Reserved								0		
	5	Reserved								0		
	6	Reserved								0		
	7	Reserved								0		
	8	Reserved								0		

SW NO.	DATA NO.	ITEM	Switch setting and function					Initial setting	Remarks
			1		0				
SW F1	1	DTMF detection time		50ms	80ms	100ms	120ms	0	
			No. 1	0	0	1	1		
	2		No. 2	0	1	0	1	0	
	3	Protection of remote reception(5××) detection	Yes			No		1	
	4	Remote reception with GE telephone	Compatible			Not compatible		1	
	5	Remote operation code figure by external TEL (0-9)	Binary input					0	
	6		No. =	8	4	2	1	1	
	7			5	6	7	8	0	
8			0	1	0	1	1		
SW F2	1	CNG detection in STAND-BY mode	Yes			No		0	
	2	Number of CNG detect(AM mode)		1 pulse	2 pulses	3 pulses	4 pulses	0	
			No. 2	0	0	1	1		
	3		No. 3	0	1	0	1	1	
	4	Number of CNG detect(STAND-BY mode)		1 pulse	2 pulses	3 pulses	4 pulses	0	
			No. 4	0	0	1	1		
			No. 5	0	1	0	1		
	5		No. 5	0	1	0	1	1	
6	Reserved						0		
7	Reserved						0		
8	Reserved						0		
SW G1	1	Reserved						0	
	2	Reserved						0	
	3	Reserved						0	
	4	Reserved						0	
	5	Reserved						0	
	6	Reserved						0	
	7	Reserved						0	
	8	Reserved						0	
SW G2	1	Reserved						0	
	2	Reserved						0	
	3	Reserved						0	
	4	Reserved						0	
	5	Reserved						0	
	6	Reserved						0	
	7	Reserved						0	
	8	Reserved						0	
SW G3	1	Reserved						0	
	2	Reserved						0	
	3	Reserved						0	
	4	Reserved						0	
	5	Reserved						0	
	6	Reserved						0	
	7	Reserved						0	
	8	Reserved						0	
SW G4	1	Reserved						0	
	2	Reserved						0	
	3	Reserved						0	
	4	Reserved						0	
	5	Reserved						0	
	6	Reserved						0	
	7	Reserved						0	
	8	Reserved						0	

SW NO.	DATA NO.	ITEM	Switch setting and function		Initial setting	Remarks
			1	0		
SW I H1	1	Reserved			0	
	2	Reserved			0	
	3	Reserved			0	
	4	Reserved			0	
	5	Reserved			0	
	6	Reserved			0	
	7	Reserved			0	
	8	Reserved			0	
SW I H2	1	Reserved			0	
	2	Reserved			0	
	3	Reserved			0	
	4	Reserved			0	
	5	Reserved			0	
	6	Reserved			0	
	7	Reserved			0	
	8	Reserved			0	
SW I I1	1	Reserved			0	
	2	Reserved			0	
	3	Reserved			0	
	4	Reserved			0	
	5	Reserved			0	
	6	Reserved			0	
	7	Reserved			0	
	8	Reserved			0	
SW I I2	1	Reserved			0	
	2	Reserved			0	
	3	Reserved			0	
	4	Reserved			0	
	5	Reserved			0	
	6	Reserved			0	
	7	Reserved			0	
	8	Reserved			0	
SW I I3	1	Reserved			0	
	2	Reserved			0	
	3	Reserved			0	
	4	Reserved			0	
	5	Reserved			0	
	6	Reserved			0	
	7	Reserved			0	
	8	Reserved			0	
SW I I4	1	Reserved			0	
	2	Reserved			0	
	3	Reserved			0	
	4	Reserved			0	
	5	Reserved			0	
	6	Reserved			0	
	7	Reserved			0	
	8	Reserved			0	

SW NO.	DATA NO.	ITEM	Switch setting and function				Initial setting	Remarks	
			1		0				
SW I5	1	Reserved					0		
	2	Reserved					0		
	3	Reserved					0		
	4	Reserved					0		
	5	Reserved					0		
	6	Reserved					0		
	7	Reserved					0		
	8	Reserved					0		
SW I6	1	Reserved					0		
	2	Reserved					0		
	3	Reserved					0		
	4	Reserved					0		
	5	Reserved					0		
	6	Reserved					0		
	7	Reserved					0		
	8	Reserved					0		
SW I7	1	Reserved					0		
	2	Reserved					0		
	3	Reserved					0		
	4	Reserved					0		
	5	Reserved					0		
	6	Reserved					0		
	7	Reserved					0		
	8	Reserved					0		
SW I8	1	Reserved					0		
	2	Reserved					0		
	3	Reserved					0		
	4	Reserved					0		
	5	Reserved					0		
	6	Reserved					0		
	7	Reserved					0		
	8	Reserved					0		
SW J1	1	Sender's phone number setting	Cannot change		Change allowed			0	
	2	Summer time setting (Daylight saving)	No		Yes			1	OPTION
	3	Ringer volume		Off	Low	Middle	High	1	OPTION
	4		No. 3	0	0	1	1		
	5	Speaker volume		Low	Low	Middle	High	1	OPTION
	6		No. 4	0	1	0	1		
	7		No. 5	0	0	1	1		
	8	Reserved					0		
SW J2	1	Handset receiver volume		Middle	Middle	Middle	High	1	OPTION
	2		No. 1	0	0	1	1		
	3	Reserved					0		
	4	Reserved					0		
	5	Reserved					0		
	6	Reserved					0		
	7	Reserved					0		
	8	Reserved					0		

SW NO.	DATA NO.	ITEM	Switch setting and function				Initial setting	Remarks	
			1		0				
SW I J3	1	Communication results printout (Transaction report)		Error	Send only	Always	No print	0	
	2		No. 1	0	0	0	0	1	
	3		No. 2	0	0	1	1	1	
		3	No. 3	0	1	0	1	1	
	4	Time format	12 hour		24 hour		1		
	5	Date format	Month-Day-Year		Day-Month-Year		1		
	6	Reserved					0		
	7	Reserved					0		
	8	Reserved				0			
SW I K1	1	Entering diag mode by pressing SPEED key	Yes		No		0		
	2	Reserved				0			
	3	Reserved				0			
	4	Reserved				0			
	5	Reserved				0			
	6	Reserved				0			
	7	Reserved				0			
	8	Reserved				0			

• Soft switch function description

SW-A1 No. 1 Protect from echo

Used to protect from echo in reception.

SW-A1 No. 2 Forced 4800BPS reception

When line conditions warrant that receptions take place at 4800 BPS repeatedly.

It may improve the success of receptions by setting at 4800BPS.

This improves the receiving document quality and reduces handshake time due to fallback during training.

SW-A1 No. 3 Footer print

When set to "1", the date of reception, the sender machine No., and the page No. are automatically recorded at the end of reception.

SW-A1 No. 4 Length limitation of copy/send/receive

Used to set the maximum page length.

To avoid possible paper jam, the page length is normally limited to 0.6 meter for copy or transmit, and 1.5 meters for receive.

It is possible to set it to "No limit" to transmit a long document, such as a computer print form, etc. (In this case, the receiver must also be set to no limit.)

SW-A1 No. 5 CSI transmission

(CSI TRANSMISSION) is a switch to set whether the machine sends or does not send the signal (CSI signal) informing its own telephone No. to the remote fax machine when information is received. When "nonsending" is set, the telephone No. is not output on the remote transmitting machine if the remote transmitting machine has the function to display or print the telephone No. of receiving machine, using this CSI signal.

SW-A1 No. 6 DIS receive acknowledgment during G3 transmission

Used to make a choice of whether reception of DIS(NSF) is acknowledged after receiving two DIS(NSFs) or receiving one DIS (two NSF). It may be useful for overseas communication to avoid an echo suppression problem, if set to 1.

SW-A1 No. 7 Non modulated carrier for V29 transmission mode

Though transmission of a nonmodulated carrier is not required for transmission by the V29 modem according to the CCITT Recommendation, it may be permitted to a send nonmodulated carrier before the image signal to avoid an echo suppression problem.

It may be useful for overseas communication to avoid an echo suppression problem, if set to 1.

SW-A1 No. 8 Reserved

Set to "1".

SW-A2 No. 1 ~ No. 4 Modem speed

Used to set the initial modem speed. The default is 9600BPS.

It may be necessary to program it to a slower speed when frequent line fallback is encountered, in order to save the time required for fallback procedure.

SW-A2 No. 5 Reserved

Set to "1".

SW-A2 No. 6 H2 mode

Used to determine reception of H2 mode (15 sec transmission mode). When set to OFF, H2 mode reception is inhibited even though the transmitting machine has H2 mode function.

SW-A2 No. 7 Communication error treatment in RTN sending mode (Reception)

Used to determine communication error treatment when RTN is sent by occurrence of a received image error in G3 reception. When it is set to "1", communication error is judged as no error.

SW-A2 No. 8 CNG transmission

When set to "0", this model allows CNG transmission by pressing the Start key in the key pad dialing mode. When set to "1", CNG transmission in the key pad dialing mode cannot be performed. In either case, CNG transmission can be performed in the auto dial mode.

SW-A3 No. 1, No. 2 CED tone signal interval

For international communication, the 2100Hz CED tone may act as an echo suppression switch, causing a communication problem.

Though SW-A3 No. 1 and No. 2 are normally set to 0, this setting is used to change the time between the CED tone signal to eliminate the communication caused by echo.

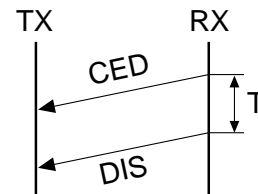

SW-A3 No. 3 MR coding

Used to select the MR coding enable or disable.

SW-A3 No. 4 ~ No. 8 Reserved

Set to "0".

SW-A4 No. 1 ~ No. 5 Signal transmission level (0~-31 dBm setting by 1dBm step)

Used to control the signal transmission level in the range of -0dB to -31dB.

The factory setting is at -10dB (MODEM output).

SW-A4 No. 6 Protocol monitor (Error Print)

If set to "1", protocol is printed at communication error.

SW-A4 No. 7 Protocol monitor

Normally set to "0". If set to "1", communication can be checked, in case of trouble, without using a G3 tester or other tools.

When communication FSK data transmission or reception is made, the data is taken into the buffer. When communication is finished, the data is analyzed and printed out. When data is received with the line monitor (SW4-No. 8) set to "1" the reception level is also printed out.

SW-A4 No. 8 Line monitor

Normally set to "0". If set to "1", the transmission speed and the reception level are displayed on the LCD. Used for line tests.

SW-A5 No. 1, No. 2 Digital equalization setting (Reception)

Line equalization when reception is to be set according to the line characteristics.

Setting should be made according to distance between the telephone and the telephone company central switching station.

SW-A5 No. 3, No. 4 Digital equalization setting (Transmitter)

Line equalization when transmission is to be set according to the line characteristics.

Setting should be made according to distance between the telephone and the telephone company central switching station.

SW-A5 No. 5, No. 6 Digital equalization setting (Reception for Caller ID)

Line equalization when reception for CALLER ID is to be set according to the line characteristics.
Setting should be made according to distance between the telephone and the telephone company central switching station.

SW-A5 No. 7 Error criterion

Used to select error criterion for sending back RTN when receiving image data.

SW-A5 No. 8 Anti junk fax check

When using the Anti junk fax function, set to "1".

SW-A6 No. 1 Auto gain control(MODEM)

When this mode is enabled, if the reception signal level is under 31dBm, the modem itself controls the signal gain automatically.

SW-A6 No. 2 End buzzer

Setting this bit to 0 will disable the end buzzer (including the error buzzer/on-hook buzzer).

SW-A6 No. 3 Disconnect the line when DIS is received in RX mode

Bit1 = 0 : When DIS signal is received during RX mode, disconnect the line immediately.

Bit1 = 1 : When DIS signal is received during RX mode, wait for the next signal.

SW-A6 No. 4 Equalizer freeze control (MODEM)

This switch is used to perform reception operation by fixing the equalizer control of modem for the line which is always in unfavorable state and picture cannot be received.

* Usually, the control is executed according to the state of line where the equalizer setting is changed always.

SW-A6 No.5 Equalizer freeze 7200BPS only

Setting which specifies SW-A6 No. 4 control only in condition of 7200BPS modem speed.

SW-A6 No. 6 CNG transmission in manual TX mode

When set to "1", fax transmit the CNG signal in case of manual transmission mode (User press the START key after waiting for the fax answering signal from handset or speaker).

SW-A6 No. 7 Initial compression scheme for sharp fax in TX mode

When set to "0", if the other fax is Sharp model, fax transmit the document by H2 mode.

When set to "1", even if the other fax is Sharp model, fax transmit the document by MR mode.

SW-A6 No. 8 Modem speed automatic down when RX level is under -40dBm

When set to "1", if fax signal level is under -40dBm during reception, machine selects the slower modem speed automatically.

It is effective when noises occur on the received document due to the long distance communications.

SW-A7 No. 1, No. 2 EOL (End Of Line) detect timer

Used to make a choice of whether to use the 5 or 13 or 20 or 25 seconds timer for detection of EOL.

This is effective to override communication failures with some facsimile models that have longer EOL detection.

SW-A7 No. 3 ~ No. 8 Reserved

Set to "0".

SW-B1 No. 1 Hold key

Used to set YES/NO of holding function by the HOLD key.

SW-B1 No. 2 Auto dial fax transmission by REDIAL key

When set to "1", if original documents are set to the feeder and you press REDIAL key, machine will dial and transmit the documents automatically.

When set to "0", operator needs to press the START key after FAX reception tone is heard.

SW-B1 No. 3 Reserved

Set to "0".

SW-B1 No. 4 ~ No. 8 Recall interval (0~15.5min setting by 0.5min step)

Choice is made for a redial interval for speed and rapid dial calls.
Use a binary number to program this with 0.5min steps. If set to 0 accidentally, 0.5min will be assumed.

SW-B2 No. 1 ~ No.4 Recall times (0~15times setting)

Choice is made as to how many redials there should be.

SW-B2 No. 5 Dial tone detection (Before auto dial)

Used to set YES/NO of dial tone detection in auto dialing.

SW-B2 No. 6 Reserved

Set to "0".

SW-B2 No. 7 Busy tone detection (After auto dial)

Used to set YES/NO of busy tone detection after auto dialing.

SW-B2 No. 8 Busy tone detection pulse number (After auto dial)

Used for detection of busy tone in 2 or 4 pulses.

SW-B3 No. 1, No. 2 Waiting time after dialing

This is waiting time for the opponent's signals after dialing.
45 / 55 / 90 / 140 seconds settings are available.

SW-B3 No. 3 ~ No. 8 Reserved

Set to "0".

SW-B4 No. 1 Dialing pause (sec/pause)

Pauses can be inserted between telephone numbers of direct dial connection. Selection of 4 sec or 2 sec pause is available.

SW-B4 No. 2 Dial mode

When using the pulse dial, set to 0. When using the tone dial, set to 1.

SW-B4 No. 3 Pulse → Tone change function by ✕ key

When setting to 1, the mode is changed by pressing the ✕ key from the pulse dial mode to the tone dial mode.

SW-B4 No. 4 Dial pulse make/break ratio (%)

When using the 33% make ratio pulse dial, set to 0.
When using the 40% make ratio pulse dial, set to 1.

SW-B4 No. 5, No. 6 Auto dial mode Delay timer of before line connect

Delay time between the dial key input and line connection under the auto dial mode.

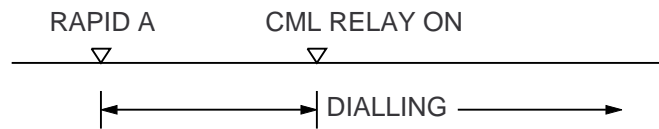

No.5=0	No.6=0	: 0sec
No.5=0	No.6=1	: 1.5sec
No.5=1	No.6=0	: 3.0sec
No.5=1	No.6=1	: 4.5sec

SW-B4 No. 7, No. 8 Reserved

Set to "0".

SW-B5 No. 1 ~ No. 3 Auto dial mode Delay timer of after line connect

Delay time between the line connection and dial data output under the auto dial mode.
This setting is available when dial tone detection(SW-B2 No. 5) is set to "NO".

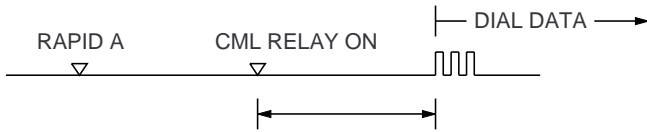

No. 1	No. 2	No. 3	
0	0	0	1.7sec
0	0	1	2.0sec
0	1	0	2.5sec
0	1	1	3.0sec
1	0	0	3.6sec
1	0	1	4.0sec
1	1	0	5.5sec
1	1	1	7.0sec

SW-B5 No. 4 Fax signal detection after telephone mode dial

When set to "1", if machine detects the fax answering signal after telephone calling (handset off-hook or speaker mode dial), machine starts to receive the documents automatically.

SW-B5 No. 5 Recalling fixed only one time when dialing was unsuccessful without detecting busy tone signal

When set to "1", if machine does not detect the busy tone after auto dialing and dialing is unsuccessful, machine will try to recall only one time.

SW-B5 No. 6 ~ No. 8 Reserved

Set to "0".

SW-B6 No. 1 ~ No. 5 DTMF signal transmission level (Low frequency 0~15.5dBm setting by 0.5dBm step)

The transmission level of DTMF signal is adjusted. (lower frequency)

00000: 0dBm

↓

11111: -15.5 dBm (-0.5dBm x 31)

SW-B6 No. 6 ~ No. 8 Reserved

Set to "0".

SW-B7 No. 1 ~ No. 5 DTMF signal transmission level (High frequency 0~15.5dBm setting by 0.5dBm step)

The transmission level of DTMF signal is adjusted. (higher frequency)

00000: 0dBm

↓

11111: -15.5 dBm (-0.5dBm x 31)

SW-B7 No. 6 ~ No. 8 Reserved

Set to "0".

SW-C1 No. 1, No. 2 Reading slice (Binary)

Used to determine the set value of reading density in standard/fine/super-fine mode.

The standard setting is "00"(Factory setting is "00").

SW-C1 No. 3, No. 4 Reading slice (Half tone)

Used to determine the set value of reading density in half tone mode.
The standard setting is "00"(Factory setting is "00").

SW-C1 No. 5 Line density selection

Used to set the transmission mode which is automatically selected when the Resolution key is not pressed. In the copy mode, however, the fine mode is automatically selected unless the Resolution key is manually set to another mode.

SW-C1 No. 6 Reserved

Set to "0".

SW-C1 No. 7 MTF correction in half tone mode

This allows selection of MTF correction (dimness correction) in the half tone mode.

When "NO" (=1) is selected, the whole image becomes soft and mild. Clearness of characters will be reduced. Normally set to "YES" (=0).

SW-C1 No. 8 Reserved

Set to "0".

SW-D1 No.1 ~ No. 4 Number of rings for auto receive (0~15rings setting)

When the machine is set in the auto receive mode, the number of rings before answering can be selected. It may be set from one to nine rings using a binary number. Since the facsimile telephone could be used as an ordinary telephone if the handset is taken off the hook, it should be programmed to the user's choice. If the soft switch was set to 1, direct connection is made to the facsimile.

If a facsimile calling beep was heard when the handset is taken off the hook, press the START key and put the handset on the hook to have the facsimile start receiving. If it was set to 0 accidentally, receive ring is set to 1.

NOTE: If the machine is set to answer after a large number of rings, it may not be able to receive faxes successfully.

If you have difficulty receiving faxes, reduce the number of rings to a maximum of 5.

SW-D1 No. 5 Automatic switching manual to auto receive function

This soft switch is used to select whether the machine should switch to the auto receive mode after 5 rings in the manual receive mode or remain in the same way as SW-D1 No. 1, No. 2, No. 3 and No. 4 "0"1"0"1"(5 rings).

SW-D1 No. 6, No. 7 Cl detect frequency

Detection frequency of ring signal for auto reception is set.

When set to No. 6=0, No. 7=0, frequency is set to PTT recommendation.

When set to No. 6=0, No. 7=1, frequency is set to 11.5Hz or more.

When set to No. 6=1, No. 7=0, frequency is set to 13.0Hz or more.

When set to No. 6=1, No. 7=1, frequency is set to 20.0Hz or more.

SW-D1 No. 8 Reserved

Set to "0".

SW-D2 No. 1 ~ No. 3 Distinctive ringing setting

When the ringing setting is turned off, all of the CI signals are received. When any of the standard, and ring patterns 1 through 3 is selected for the ringing setting, only the selected CI signal is received.

CI signal patterns

The CI signal patterns consists of the standard pattern, and ring patterns 1 through 7. The standard pattern is the conventional one.

STANDARD	
RING PATTERN 1 for USA	
RING PATTERN 2 for USA	
RING PATTERN 3 for USA	
RING PATTERN 1 for CANADA	
RING PATTERN 2 for CANADA	
RING PATTERN 3 for CANADA	

SW-D2 No. 4, No. 5 Reserved

Set to "0".

SW-D2 No. 6 Caller ID Function

Used for Caller ID function.

SW-D2 No. 7, No. 8 Reserved

Set to "0".

SW-D3 No. 1 ~ No. 5 CI off detection timer (0~1550ms setting by 50ms step)

Set the minimum time period of CI signal interruption which affords to be judged as a CI OFF section with 50ms steps. (Example)

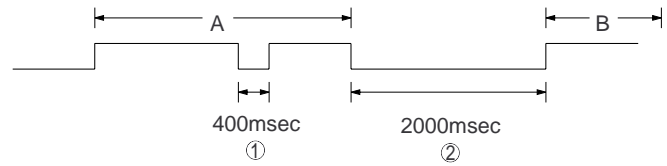

0 1 1 1 0 (50ms~14) : 700ms(CI interruption>700ms:Judged as a CI OFF section)

The section 1 is not judged as a CI OFF section, the CI signal A is counted as one signal. The section 2 is judged as a CI OFF section, the CI signal B is considered as the second signal.

0 0 1 1 1 (50ms~7) : 350ms(CI interruption>350ms:Judged as a CI OFF section)

The section 1 is judged as a CI OFF section, and the CI signal A is counted as two signals. The section 2 is judged as a CI OFF section, and the CI signal B is considered as the third signal.

SW-D3 No. 6 ~ No. 8 Reserved

Set to "0".

SW-D4 No. 1 ~ No. 6 DTMF type Caller ID RX level (0~44dBm setting by 1dBm step)

This is used for DTMF type Caller ID detection level setting.

SW-D4 No. 7, No. 8 Reserved

Set to "0".

SW-E1 No. 1 ~ No. 8 Reserved

Set to "0".

SW-E2 No. 1 ~ No. 8 Reserved

Set to "0".

SW-E3 No. 1 ~ No. 8 Reserved

Set to "0".

SW-F1 No. 1, No. 2 DTMF detection time

Used to set detect time of DTMF (Dual Tone Multi Frequency) used in remote reception(5××).

The longer the detect time is, the less the error detection is caused by noises.

SW-F1 No. 3 Protection of remote reception (5××) detection

Used to set the function of remote reception (5××). When set to "1", the remote reception function is disabled.

SW-F1 No. 4 Remote reception with GE telephone

"1": Compatible with TEL mode by GE

"0": Not compatible

- When sending (5××) for remote reception with a GE manufactured telephone remote reception may not take place because of special specifications in their DTMF.

To overcome this, a soft SW is provided to change the modem setting to allow for remote reception.

- If this soft SW is set to "1", other telephone sets may be adversely affected.

SW-F1 No. 5 ~ No. 8 Remote operation code figure by external TEL (0~9)

Remote operation codes can be changed from 0 through 9. If set to greater than 9, it defaults to 9. The "5××" is not changed.

Ex- 7×× (Default : 5××)

SW-F2 No. 1 CNG detection in STAND-BY mode

When setting to "1", the CNG signal detection function during standby stops.

SW-F2 No. 2, No. 3 Number of CNG detect (AM mode)

Used for detection of CNG in 1 to 4 pulses.

SW-F2 No. 4, No. 5 Number of CNG detect (STAND-BY mode)

Used for detection of CNG in 1 to 4 pulses.

SW-F2 No. 6 ~ No. 8 Reserved

Set to "0"

SW-G1 No. 1 ~ No. 8 Reserved

Set to "0"

SW-G2 No. 1 ~ No. 8 Reserved

Set to "0"

SW-G3 No. 1 ~ No. 8 Reserved

Set to "0".

SW-G4 No. 1 ~ No. 8 Reserved

Set to "0".

SW-H1 No. 1 ~ No. 8 Reserved

Set to "0".

SW-H2 No. 1 ~ No. 8 Reserved

Set to "0".

SW-I1 No. 1 ~ No. 8 Reserved

Set to "0".

SW-I2 No. 1 ~ No. 8 Reserved

Set to "0".

SW-I3 No. 1 ~ No. 8 Reserved

Set to "0".

SW-I4 No. 1 ~ No. 8 Reserved

Set to "0".

SW-I5 No. 1 ~ No. 8 Reserved

Set to "0".

SW-I6 No. 1 ~ No. 8 Reserved

Set to "0".

SW-I7 No. 1 ~ No. 8 Reserved

Set to "0".

SW-I8 No. 1 ~ No. 8 Reserved

Set to "0".

SW-J1 No. 1 Sender's phone number setting

Used to make a choice of whether the registered sender's phone number can be changed or not. If the switch is set to "1", new registration of the sender's phone number is disabled to prevent accidental wrong input.

SW-J1 No. 2 Summer time setting (Daylight saving)

Used to set YES/NO of automatic clock adjustment for Summer time(Daylight saving time).

SW-J1 No. 3, No. 4 Ringer Volume

Used to adjust ringing volume.

SW-J1 No. 5, No. 6 Speaker Volume

Used to adjust sound volume from a speaker.

SW-J1 No. 7, No. 8 Reserved

Set to "0".

SW-J2 No. 1, No. 2 Handset receiver volume

Used to adjust sound volume from a handset receiver volume.

SW-J2 No. 3 ~ No. 8 Reserved

Set to "0".

SW-J3 No. 1 ~ No. 3 Communication results printout (Transaction report)

It is possible to obtain transaction results after each communication. Normally, the switch is set (No. 1 : 0, No. 2 : 0, No. 3 : 0) so that the transaction report is produced only when a communication error is encountered.

If No.1 was set to 0 and No. 2 to 1 and No. 3 to 0, the transaction report will be produced every time a communication is done, even if the communication was successful.

Setting No. 1 to 0 and No. 2 to 1 and No. 3 to 1 will disable this function. No transaction report printed.

SW-J3 No. 4 Time format

When set to "0", 24hour time format is used.

When set to "1", 12hour time format is used.

SW-J3 No. 5 Date format

When set to "0", Day-Month-Year format is used.

When set to "1", Month-Day-Year format is used.

SW-J3 No. 6 ~ No. 8 Reserved

Set to "0".

SW-K1 No. 1 Entering diag mode by pressing SPEED key

A bit which is used in the production process only. When the SPEED key is pressed, the switch is changed from the stand-by state to the diag mode.

SW-K1 No. 2 ~ No. 8 Reserved

Set to "0".

[3] Troubleshooting

Refer to the following actions to troubleshoot any of the problems mentioned in 1-4.

[1] A communication error occurs.

[2] Image distortion produced.

[3] Unable to do overseas communication.

[4] Communication speed slow due to FALLBACK.

- Increase the transmission level SOFT SWITCH A4-1, 2, 3, 4, 5. May be used in case [1] [2] [3].
- Decrease the transmission level SOFT SWITCH A4-1, 2, 3, 4, 5. May be used in case [3].

- Apply line equalization SOFT SWITCH A5-1, 2. May be used in case [1] [2] [3] [4].
- Slow down the transmission speed SOFT SWITCH A2-1, 2, 3, 4. May be used in case [2] [3].
- Replace the TEL/LIU PWB. May be used in all cases.
- Replace the control PWB. May be used in all cases.

* If transmission problems still exist on the machine, use the following format and check the related matters.

TO: _____ ATT: _____ Ref.No.: _____
 CC: _____ ATT: _____ Date: _____
 FM: _____ Dept: _____
 _____ Sign: _____

***** Facsimile communication problem *****				Ref.No.:																					
From: Mr. _____		Fax Tel No.: _____		Date: _____																					
Our customer	Name _____	Tel No. _____																							
	Address _____	Fax No. _____																							
	Contact person _____	Model name _____																							
Other party	Name _____	Tel No. _____																							
	Address _____	Fax No. _____																							
	Contact person _____	Model name _____																							
Problem mode	Line: Domestic / international _____	Model: G3	Phase: A, B, C, D.																						
	Reception / Transmission _____	Automatic reception / Manual reception Automatic dialing / Manual dialing / Others																							
Frequency: _____	% _____	ROM version: _____																							
Confirmation item				Please mark problem with an X. No problem is: 0.																					
				<table border="1" style="width:100%; text-align:center;"> <tr> <td>A1</td><td>A2</td><td>B1</td><td>B2</td><td>C1</td><td>C2</td><td>D1</td><td>D2</td><td>E1</td><td>E2</td> </tr> <tr> <td> </td><td> </td><td> </td><td> </td><td> </td><td> </td><td> </td><td> </td><td> </td><td> </td> </tr> </table>		A1	A2	B1	B2	C1	C2	D1	D2	E1	E2										
				A1	A2	B1	B2	C1	C2	D1	D2	E1	E2												
Transmission level setting is () dB at our customer																									
Transmission level () dBm Reception level () dBm By level meter at B1 and B2																									
Comment																									
Countermeasure																									
**** Please attach the G3 data and activity report on problem. ****																									

* Please complete this report before calling the "TAC" hotline if problem still occurs.

[4] Error code table

1. Communication error code table

G3 Transmission

Code	Final received signal	Error Condition (Receiver side)
0	Incomplete signal frame	Cannot recognize bit stream after flag
1	NSF, DIS	Cannot recognize DCS signal by echo etc. Cannot recognize NSS signal (FIF code etc)
2	CFR	Disconnects line during reception (carrier missing etc)
3	FTT	Disconnects line by fall back
4	MCF	Disconnects line during reception of multi page Cannot recognize NSS, DCS signal in the case of mode change
5	PIP or PIN	The line is hung up without replying to telephone request from the receiving party.
6	RTN or RTP	Cannot recognize NSS, DCS signal after transmit RTN or RTP signal.
7	No signal or DCN	No response in receiver side or DCN signal received* (transmitter side)
8	–	In some page, the error could not be corrected although the specified number of error retransmissions were attempted.
11	–	Error occurred after or while reception by the remote (receiving) machine was revealed to be impossible.
12	–	Error occurred just after fallback.
13	–	Error occurred after a response to retransmission end command was received.

G3 Reception

Code	Final received signal	Error Condition (Receiver side)
0	Incomplete signal frame	Cannot recognize bit stream after flag
1	NSS, DCS	Cannot recognize CFR or FTT signal Disconnects line during transmission (line error)
2	NSC, DTC	Cannot recognize NSS signal (FIF code etc)
3	EOP	Cannot recognize MCF, PIP, PIN, RTN, RTP signal
4	EOM	Cannot recognize MCF, PIP, PIN, RTN, RTP signal in the case of mode change
5	MPS	The line is hung up without replying to communication request.
6	PR1-Q	Cannot recognize PIP, PIN signal in the case of TALK request
7	No signal or DCN	No response in transmitter (cannot recognize DIS signal) or DCN signal received* (receiver side)
8	–	Error occurred upon completion of reception of all pages.
9	–	Error occurred when mode was changed or Transmission/Reception switching was performed.
10	–	Error occurred during partial page or physical page reception.
11	–	Error occurred after or during inquiry from the remote (transmitting) machine as to whether reception is possible or not.
12	–	Error occurred during or just after fallback.
13	–	Error occurred after the retransmission end command was received.

CHAPTER 3. MECHANISM BLOCKS

[1] General description

1. Document feed block and diagram

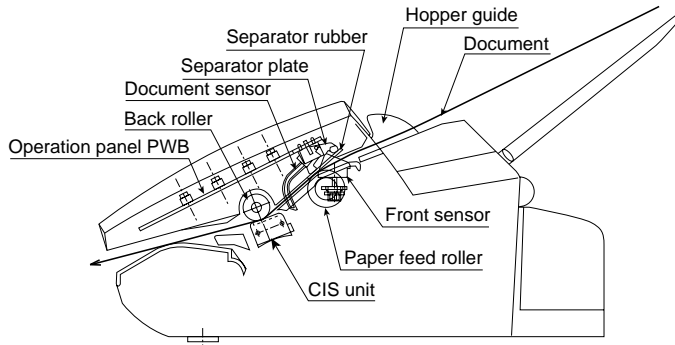

Fig. 1

2. Document feed operation

- 1) The original, which is set in the document hopper, feeds automatically when the front sensor is activated. This in turn activates the pulse motor which drives the document supply roller. The document stops when the lead edge is detected by the document sensor.
- 2) The lead edge of the original is fed a specified number of pulses after the lead edge of the document is detected for the reading process to begin.
- 3) The trailing edge of the original is fed a specific number of pulses after the trailing edge of the document deactivates the document sensor. The read process then stops and the original is discharged.
- 4) When the front sensor is in the OFF state (any document is not set up in the hopper guide), the drive will be stopped when the document is discharged.

3. Hopper mechanism

3-1. General view



Fig. 2

The hopper section contains document guides that are used to adjust the hopper to the width of the original document. This ensures that the original feeds straight into the fax machine for scanning.

Document width: 148 mm to 216 mm (A5 longitudinal size to Letter longitudinal size)

NOTE: Adjust the document guide after setting up the document.

3-2. Automatic document feed

- 1) Use of the paper feed roller and separation rubber plate ensures error-free transport and separation of documents. The plate spring presses the document to the paper feed roller to assure smooth feeding of the document.
- 2) Document separation method: Separation rubber plate

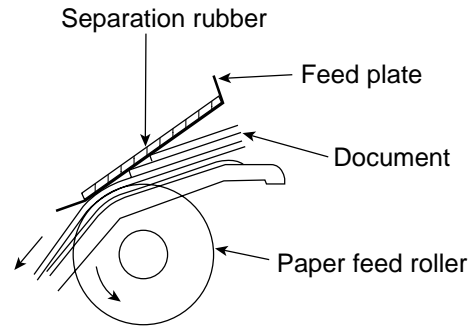

Fig. 3

3-3. Documents applicable for automatic feed

	4x6 series (788mm x 1091mm x 1000mm sheets)		Square meter series	
	Minimum	Maximum	Minimum	Maximum
Feeder capacity	5 sheets, max.			
Paper weight	45kg	69.2kg	52g/m ²	80g/m ²
Paper thickness (ref.)	0.06mm	0.09mm	0.06mm	0.09mm
Paper size	148mm x 140mm ~ A4 (210mm x 297mm), Letter (216mm x 279mm)			

NOTE: Double-side coated documents and documents on facsimile recording paper should be inserted manually. The document feed quantity may be changed according to the document thickness.

Documents corresponding to a paper weight heavier than 69.2kg (80g/m²) and lighter than 135kg (157g/m²) are acceptable for manual feed.

Documents heavier than 135kg in terms of the paper weight must be duplicated on a copier to make it operative in the facsimile.

3-4. Loading the documents

- 1) Make sure that the documents are of suitable size and thickness, and free from creases, folds, curls, wet glue, wet ink, clips, staples and pins.
- 2) Place documents face down in the hopper.
 - i) Adjust the document guides to the document size.
 - ii) Align the top edge of documents and gently place them into the hopper. The first page under the stack will be taken up by the feed roller to get ready for transmission.

NOTES: 1) Curled edge of documents, if any, must be straightened out.

2) Do not load the documents of different sizes and/or thicknesses together.

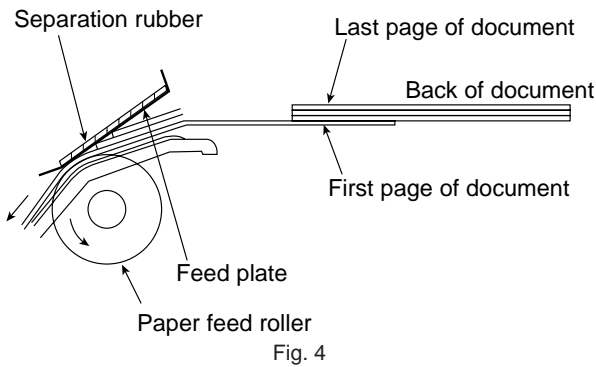

3-5. Documents requiring use of document carrier

- 1) Documents smaller than 148mm x 140mm.
- 2) Documents thinner than the thickness of 0.06mm.
- 3) Documents containing creases, folds, or curls, especially those whose surface is curled (maximum allowable curl is 5mm).
- 4) Documents containing tears.
- 5) Carbon-backed documents. (Insert a white sheet of paper between the carbon back and the document carrier to avoid transfer of carbon to the carrier.)
- 6) Documents containing an easily separable writing material (e.g., those written with a lead pencil).
- 7) Transparent documents.
- 8) Folded or glued documents.

Document in document carrier should be inserted manually into the feeder.

4. Document release

4-1. General

To correct a jammed document or to clean the document running surface, pull the insertion side of document center of the operation panel. To open the upper document guide, the operation panel must be opened first.

4-2. Cross section view

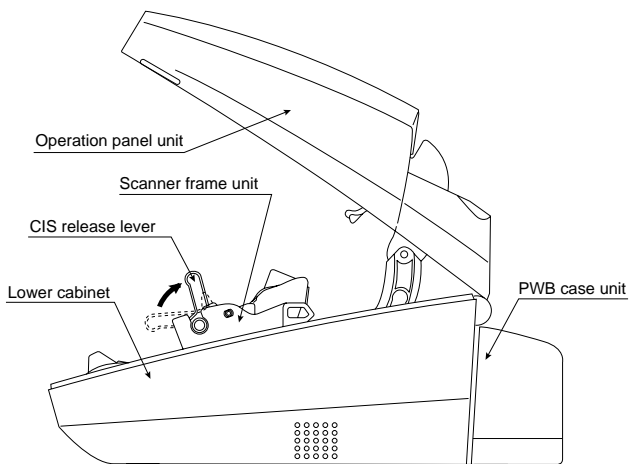

Fig. 5

5. Recording block

5-1. General view

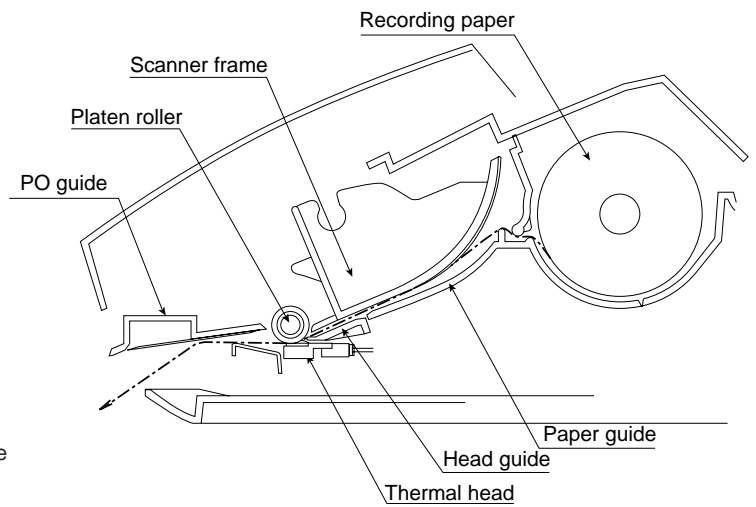

Fig. 6

5-2. Driving

Via the pulse motor gear shaft, the reduction gear, and the recording paper feed gear, rotation of the pulse motor is conveyed to the recording paper feed roller to feed the recording paper.

5-3. Recording

Use of a thermal head permits easier maintenance and low operating costs.

1) Thermal head

The thermal head consists of 1728-dot heat elements arranged in a single row and has the resolution of 8 dots/mm. The maximum recording speed is 10ms/line. The thermal head also incorporates a 1728-dot shift register latch and output control driver circuit. Low power consumption is achieved by dividing the head into nine segments.

2) Structure of the recording mechanism

Recording is accomplished by pressing the thermal head on the recording paper against the platen roller.

The main scan (horizontal) is electronically achieved, while the subscan (vertical) is achieved by moving the recording paper by the recording platen roller.

Usually, the cause for uneven print tone is caused by misalignment of the thermal head or uneven contact with the roller.

It can be checked in the following manner.

- 1) Check if the thermal head power and signal cables are properly routed.
- 2) Check that the thermal head pivot moves smoothly up and down.
- 3) Check that the thermal head support bracket is secured without any play.
- 4) Check to see that the recording platen roller has proper concentricity, in the case of a print tone variation evenly repeated down the page.
- 5) Replace the thermal head with a new one and check to see if the same trouble occurs.

[2] Disassembly and assembly procedures

- This chapter mainly describes the disassembly procedures. For the assembly procedures, reverse the disassembly procedures.
- Easy and simple disassembly/assembly procedures of some parts and units are omitted. For disassembly and assembly of such parts and units, refer to the Parts List.
- The numbers in the illustration, the parts list, and the flowchart in each section are common to each other.
- To assure reliability of the product, the disassembly and the assembly procedures should be performed carefully and deliberately.

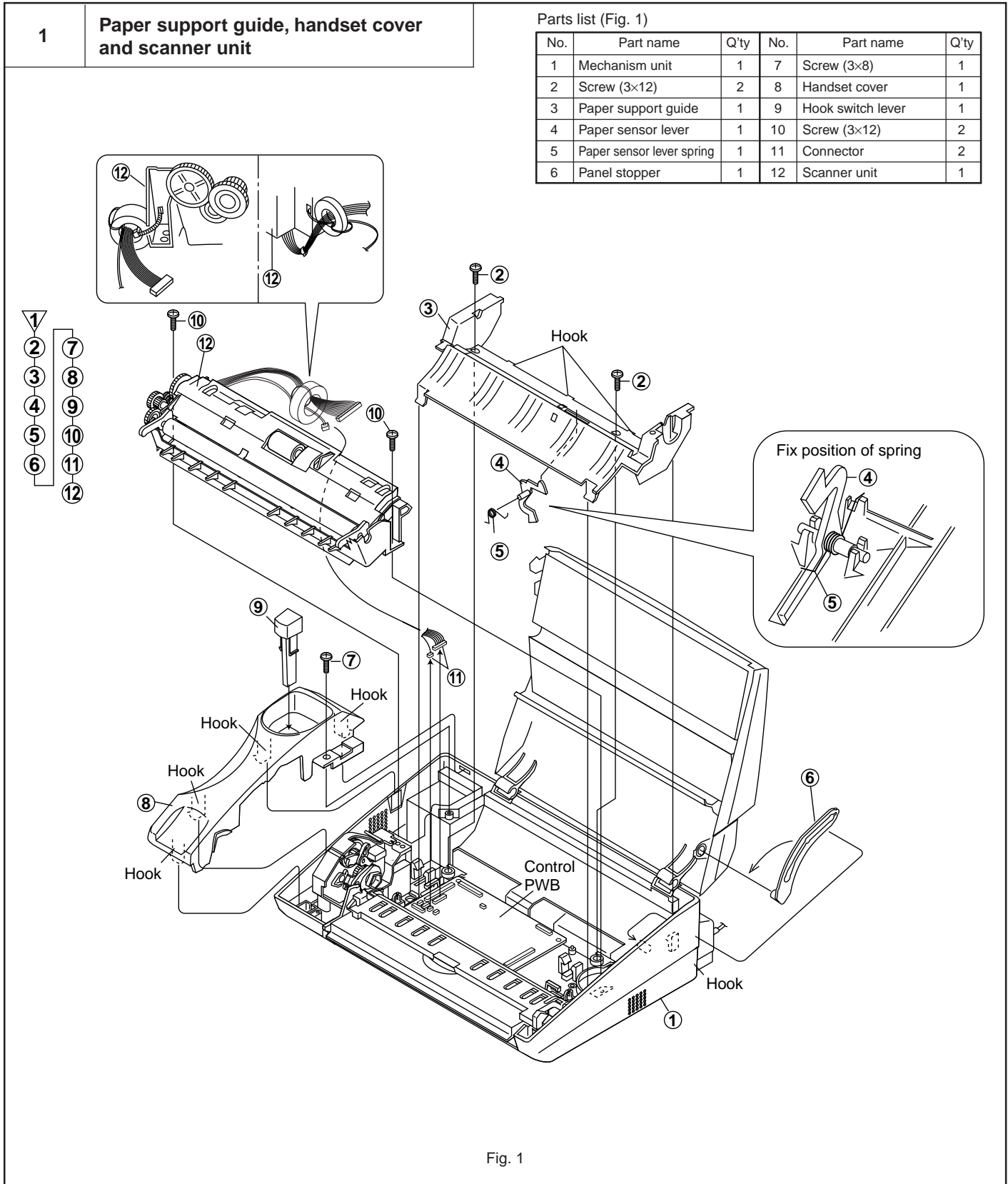

2

CIS unit and scanner frame

Parts list (Fig. 2)

No.	Part name	Q'ty	No.	Part name	Q'ty
1	Document guide lower	1	11	Feed roller	1
2	Back roller gear	1	12	Connector	1
3	Back roller bearing, left	1	13	CIS support, left	1
4	CIS release lever, left	1	14	CIS support, right	1
5	Back roller	1	15	CIS unit	1
6	CIS release lever, right	1	16	CIS protect sheet	1
7	Back roller bearing, right	1	17	CIS spring	2
8	Reduction gear, 17/28z	1	18	Connector	1
9	Reduction gear, 17/23z	1	19	Front sensor	1
10	Feed roller shaft	1	20	Scanner frame	1

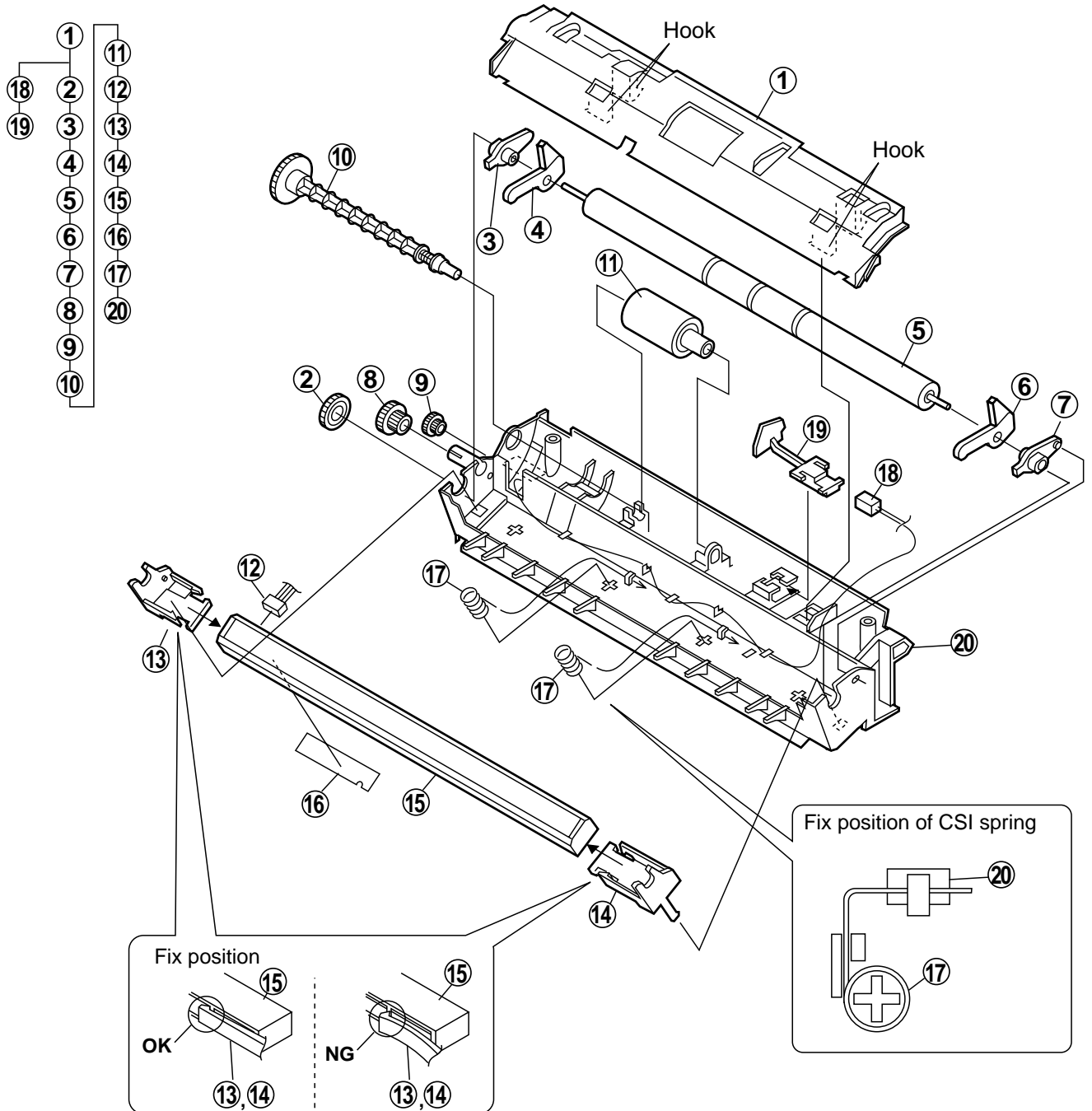

Fig. 2

3

Operation panel unit, drive unit, hopper guide

Parts list (Fig. 3)

No.	Part name	Q'ty	No.	Part name	Q'ty
1	Mechanism unit	1	9	Operation panel unit/ document guide upper unit	1
2	Connector	2	10	Screw	1
3	Operation panel unit	1	11	Pinion gear	1
4	Connector	2	12	Hopper spring	1
5	Screw (3×12)	1	13	Hopper guide, left	1
6	Drive unit	1	14	Hopper guide, right	1
7	Screw (3×8)	2	15	Hopper guide	1
8	Hopper guide unit	1			

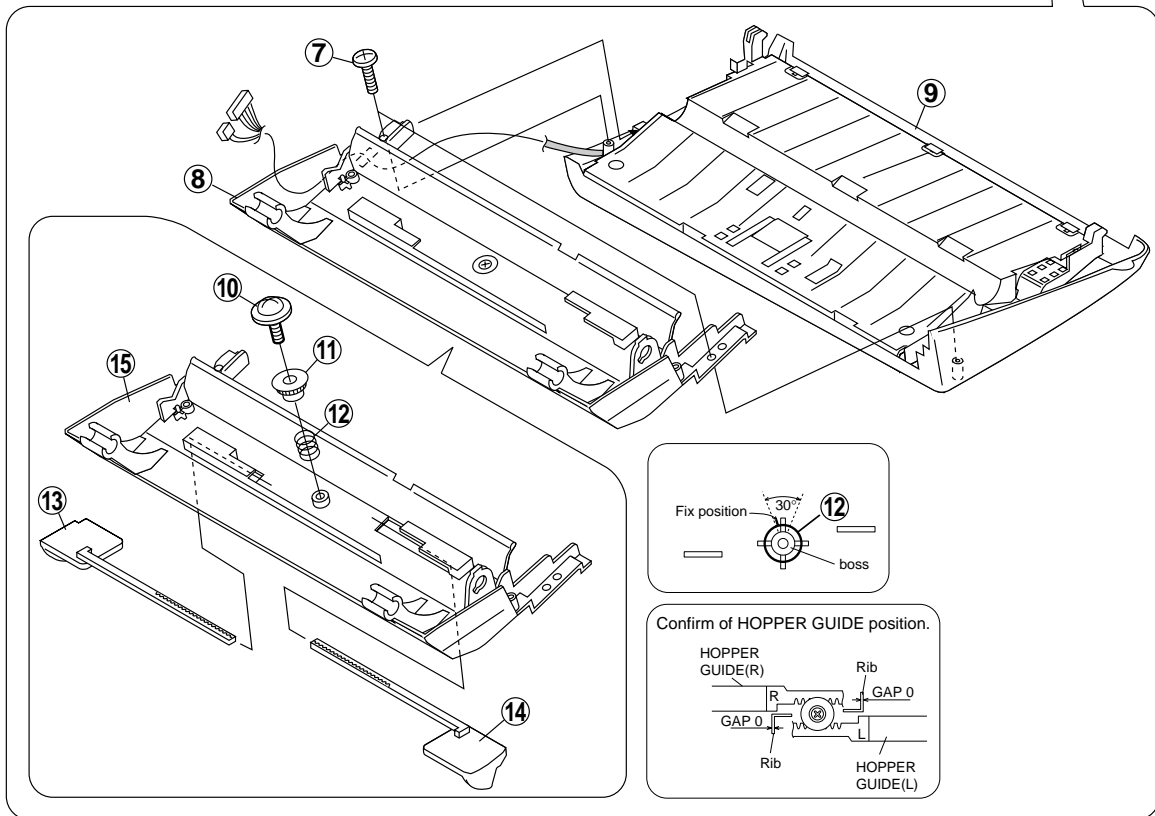
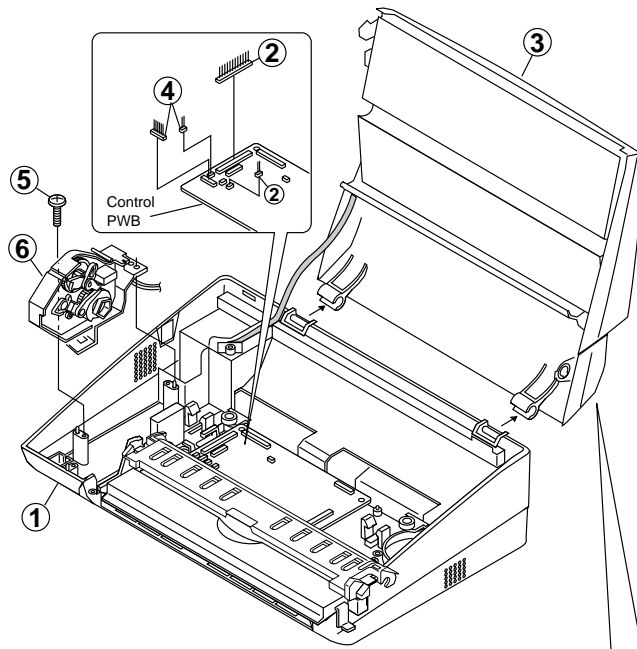
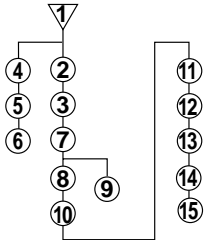

Fig. 3

4

Upper cabinet and document guide upper

Parts list (Fig. 4)

No.	Part name	Q'ty	No.	Part name	Q'ty
1	Screw (3×8)	2	10	Feed spring	1
2	Connector	1	11	Feed plate	1
3	Door sensor	1	12	Document guide upper	1
4	Blind sheet	1	13	Screw (2×6)	3
5	Document guide upper unit	1	14	Connector	1
6	Operation panel unit	1	15	Operation panel PWB unit	1
7	Separate spring	1	16	Direct key	1
8	Separator plate	1	17	Start key	1
9	Separator rubber	1	18	12 key	1
			19	Upper cabinet	1

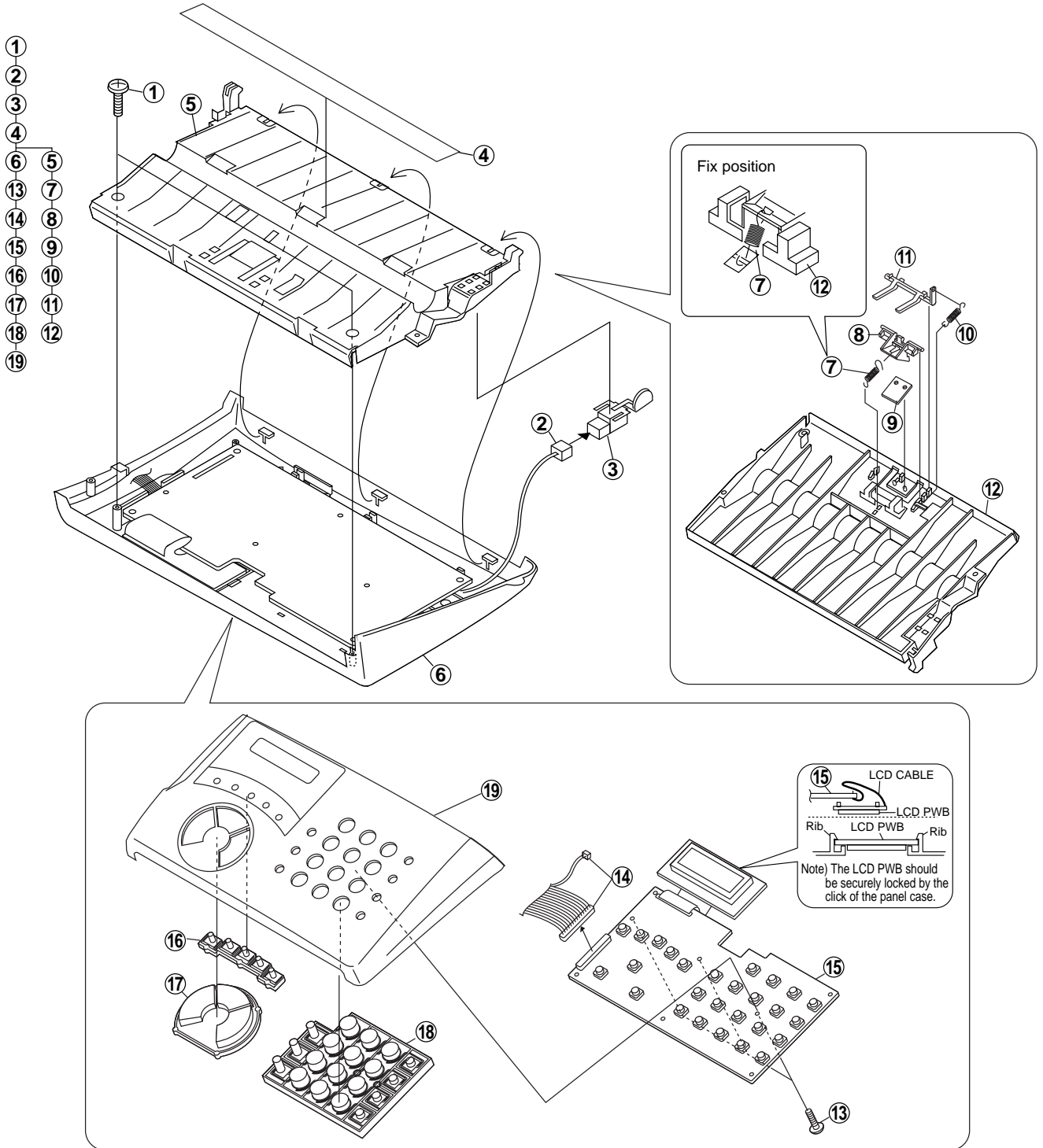

Fig. 4

5 Drive unit frame

Parts list (Fig. 5)

No.	Part name	Q'ty	No.	Part name	Q'ty
1	Cam spring	1	10	Planet lever B	1
2	Cam switch	1	11	Planet gear	1
3	Cam gear	1	12	Planet gear spring	1
4	Mode lever	1	13	Reduction gear, 17/30Z	1
5	Planet gear	1	14	Reduction gear, 17/43Z	1
6	Planet gear spring	1	15	Idler gear, 25Z	1
7	Planet lever A	1	16	Screw (3×8)	1
8	Planet gear	1	17	Motor	1
9	Planet gear spring	1	18	Motor plate	1
			19	Drive unit frame	1

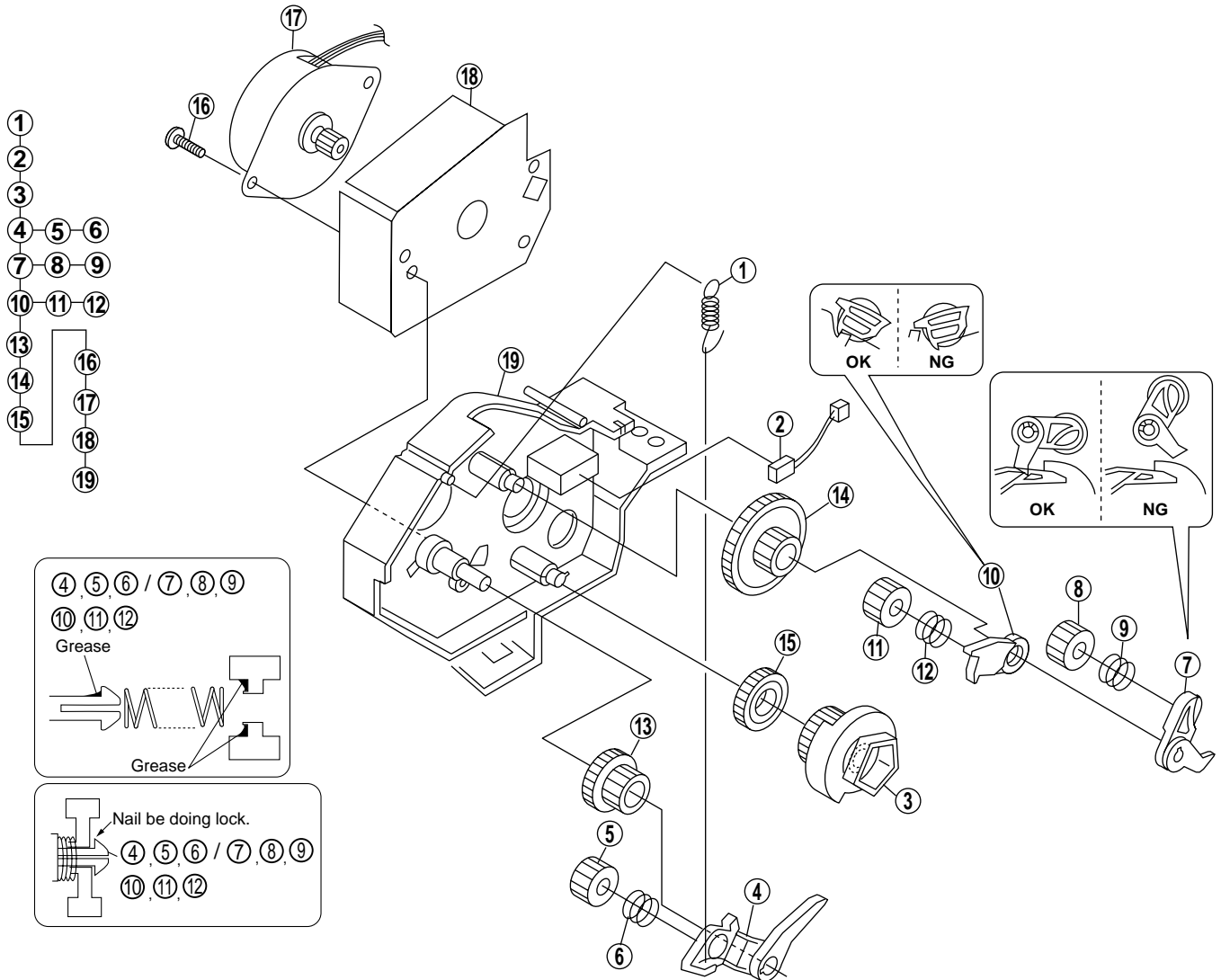

Fig. 5

6

Release lever, PO guide and head guide

Parts list (Fig. 6)

No.	Part name	Q'ty
1	Mechanism unit	1
2	Screw (3x8)	1
3	PO guide	1
4	Release lever	1
5	Head guide	1

- 1
- 2
- 3
- 4
- 5

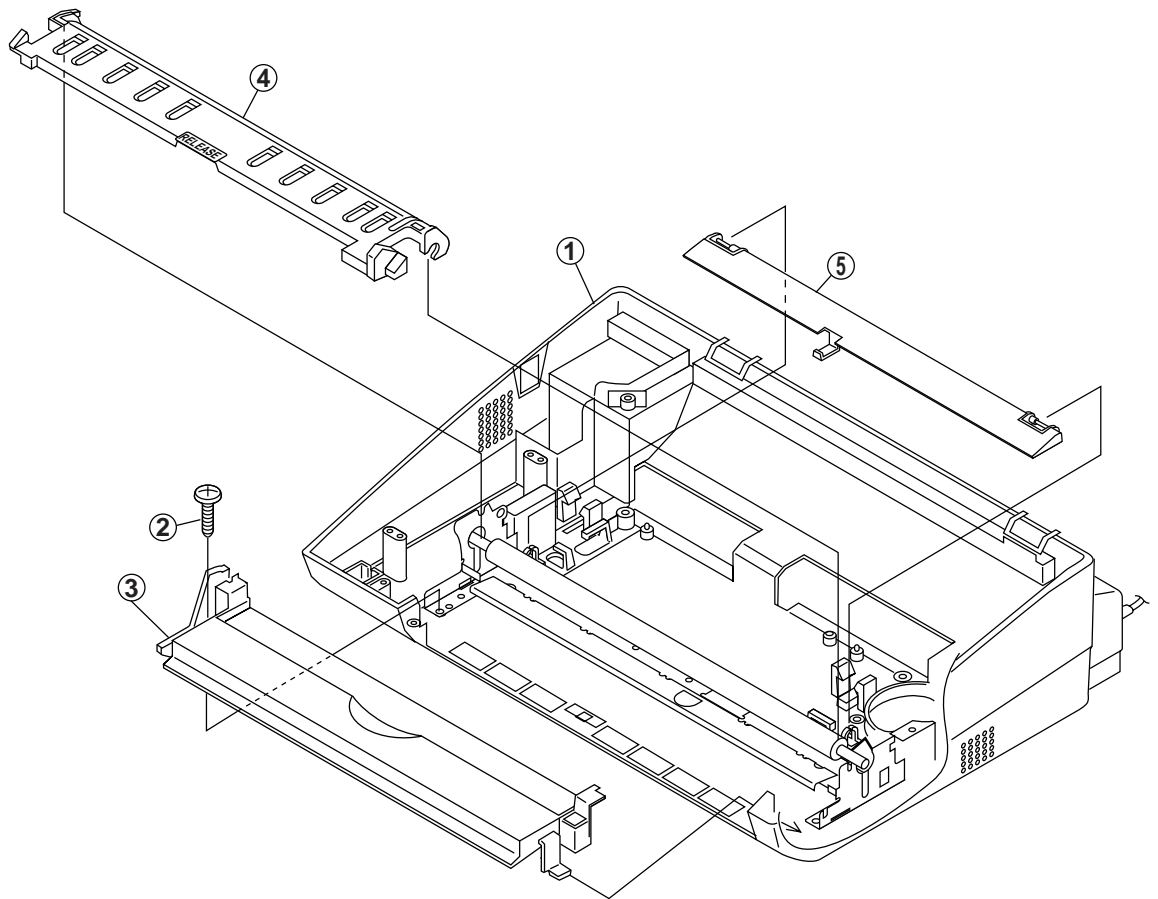

Fig. 6

7 Head frame unit

Parts list (Fig. 7)

No.	Part name	Q'ty
1	Mechanism unit	1
2	Screw (3×6)	1
3	Connector	1
4	Screw (3×8)	1
5	Head earth cable	1
6	Head frame unit	1
7	Screw (3×8)	2
8	Panel lock lever spring	2

- ①
- ②
- ③
- ④
- ⑤
- ⑥
- ⑦
- ⑧

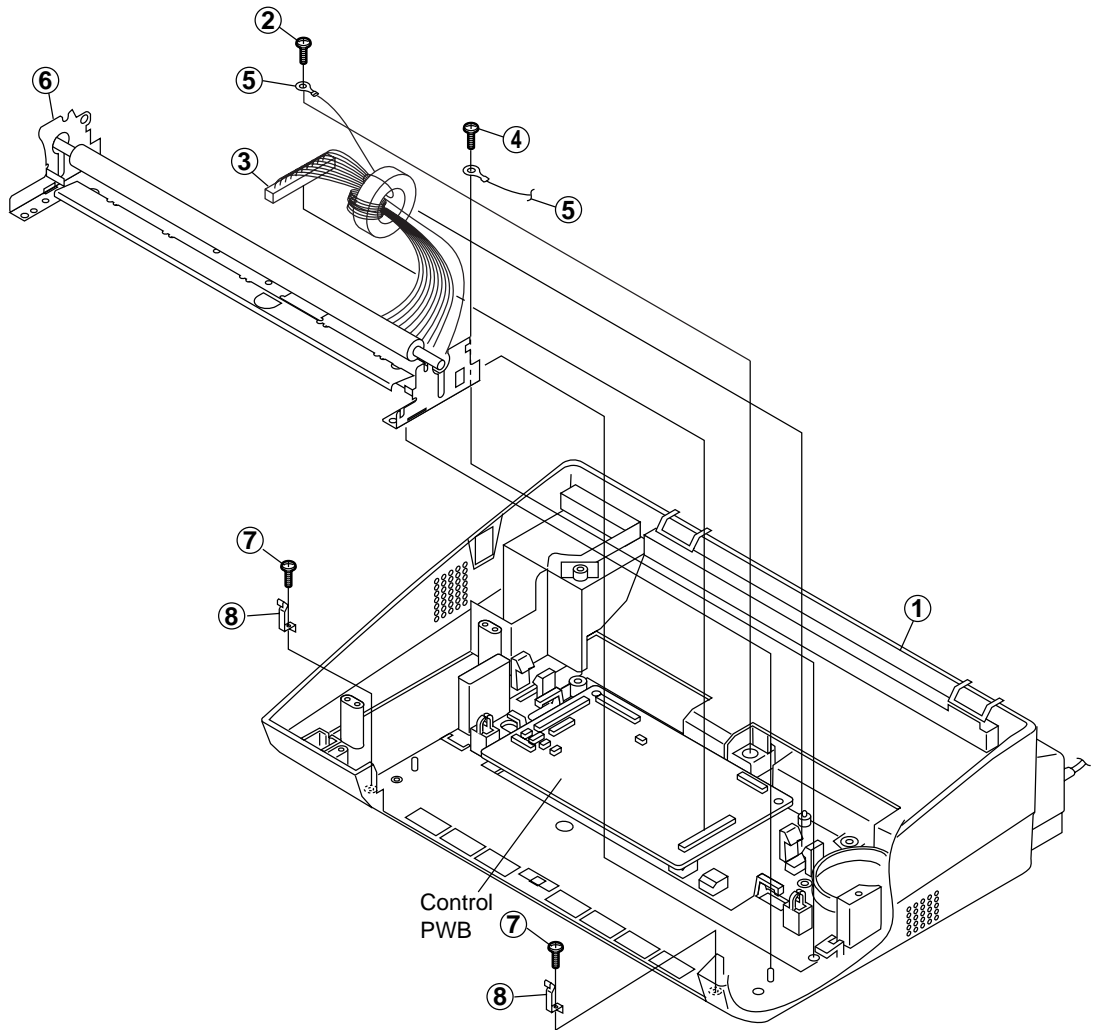

Fig. 7

8 Head frame and thermal head

Parts list (Fig. 8)

No.	Part name	Q'ty	No.	Part name	Q'ty
1	Platen gear	1	7	Screw (3×6)	1
2	Platen bearing	2	8	Head holder, right	1
3	Platen roller	1	9	Thermal head	1
4	Connector	1	10	Head spring 2	2
5	Screw (3×6)	1	11	Head spring 1	3
6	Head holder, left	1	12	Head frame	1

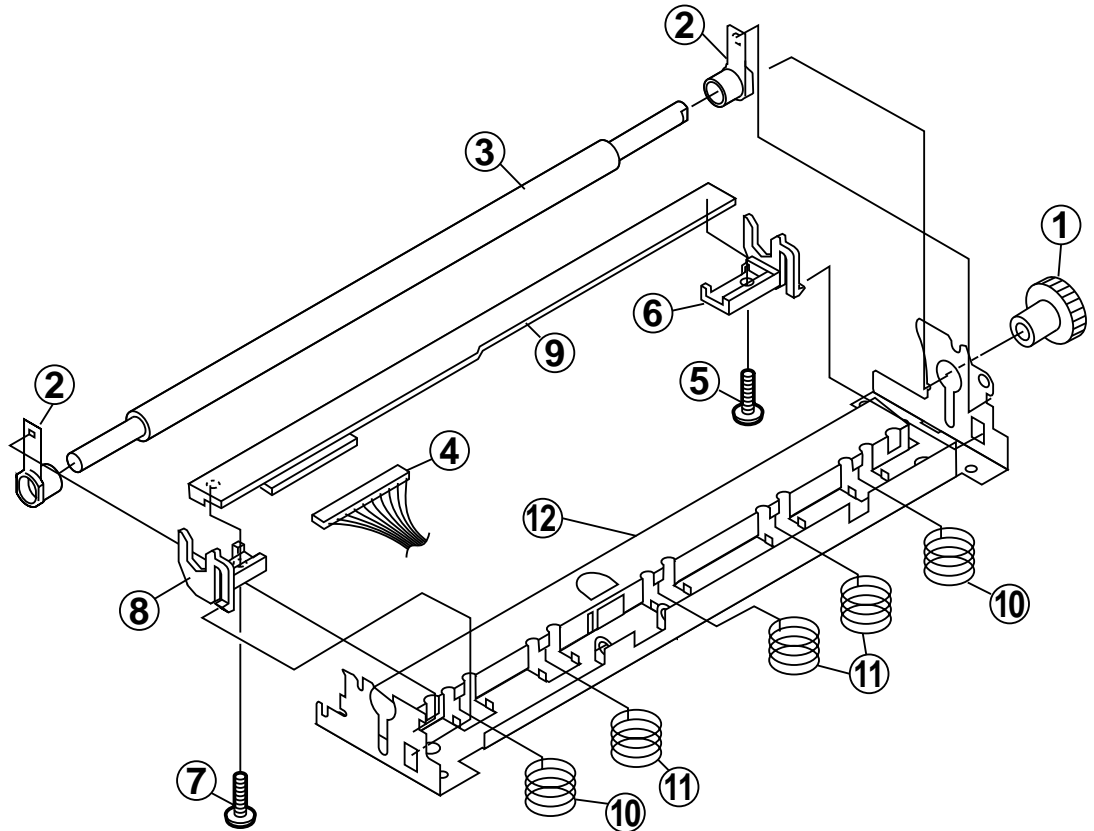
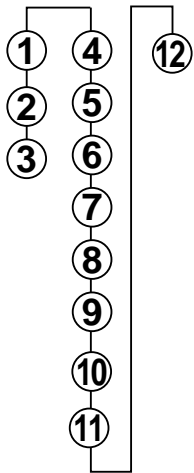

Fig. 8

9

PWB case top, bottom, PWB and speaker

Parts list (Fig. 9)

No.	Part name	Q'ty	No.	Part name	Q'ty
1	Mechanism unit	1	11	Screw (3×8)	2
2	Screw (3×8)	1	12	Hook switch joint lever	1
3	Connector	1	13	PWB case, top	1
4	Connector	2	14	PWB case, bottom unit	1
5	PWB case unit	1	15	Screw (3×6)	1
6	Screw (3×8)	1	16	TEL/LIU PWB unit	1
7	Control PWB unit	1	17	Screw (4×6)	1
8	Screw (3×8)	1	18	AC cord ass'y	1
9	Speaker holder lever spring	1	19	Power supply PWB unit	1
10	Speaker ass'y	1	20	PWB case, bottom	1

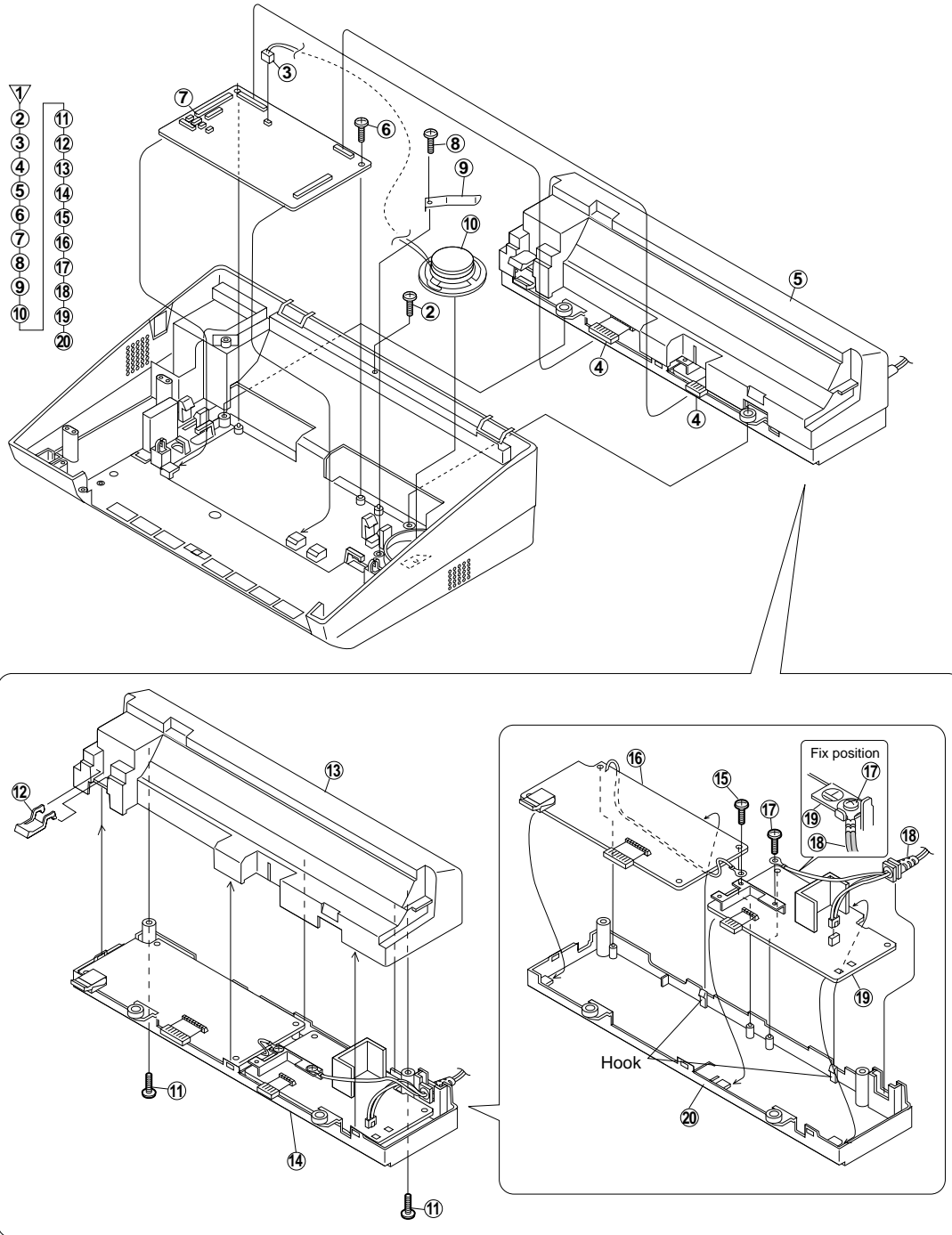

Fig. 9

10 Wire treatment

Parts list (Fig. 10)

No.	Part name	Q'ty
1	Core (F2125)	2
2	Screw (3x6)	1
3	Screw (4x6)	1
4	Screw (3x6)	1
5	Band (100mm)	3
6	Core (F2123)	1
7	Screw (3x8)	1

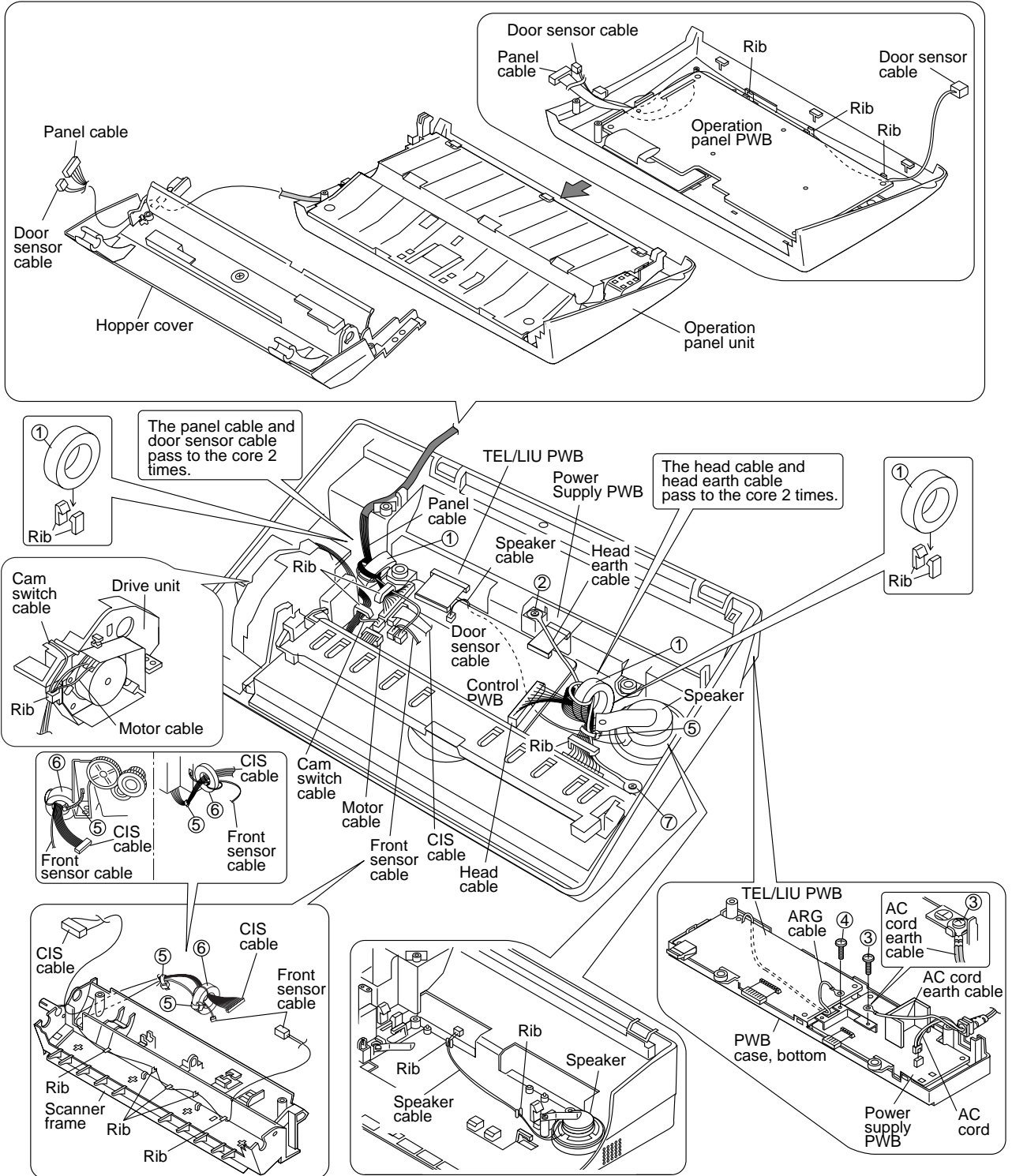
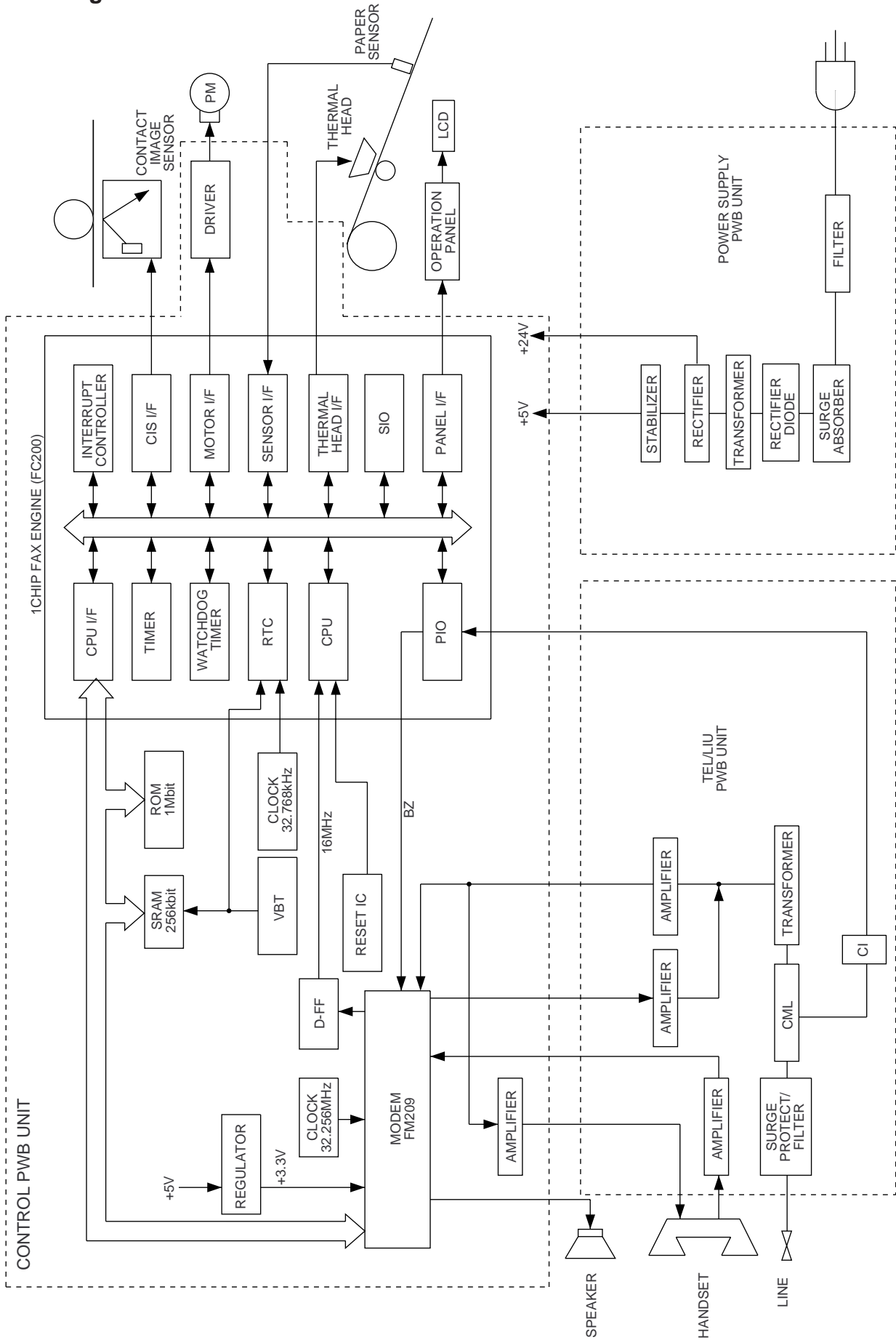

Fig. 10

CHAPTER 4. DIAGRAMS

[1] Block diagram



[2] Wiring diagram

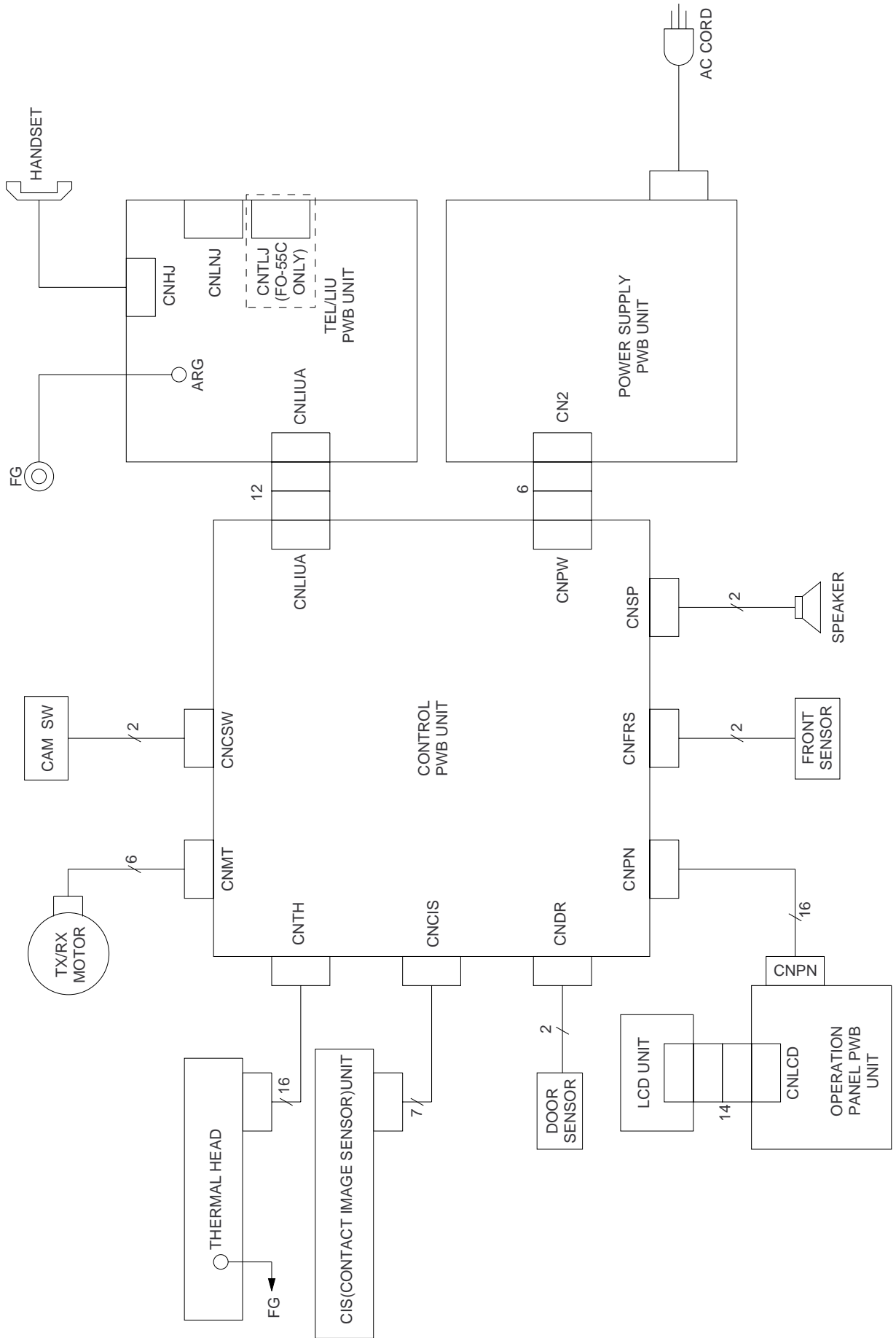

[3] Point- to-point diagram

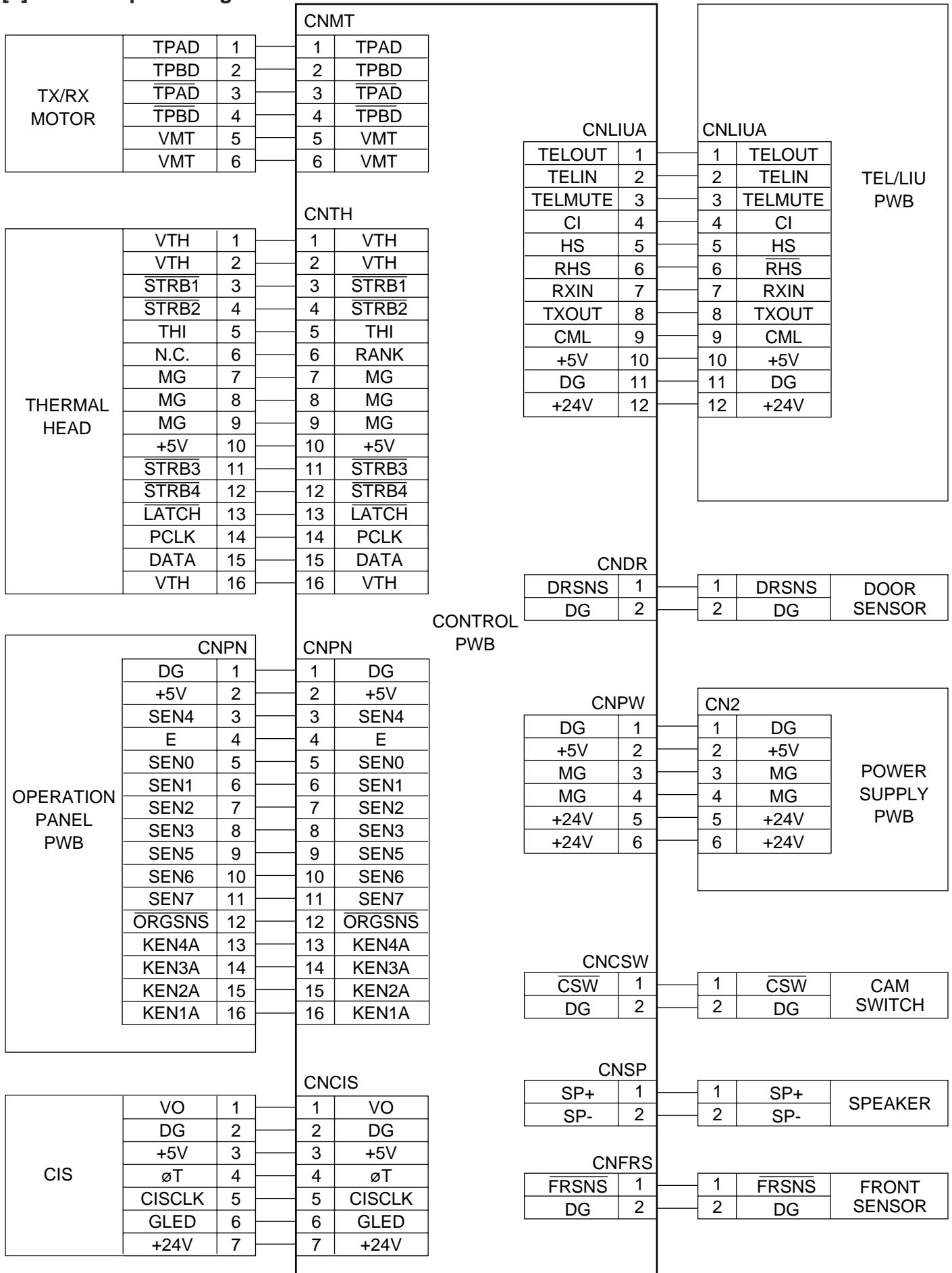

CHAPTER 5. CIRCUIT DESCRIPTION

[4] Circuit description of power supply PWB

1. Block diagram

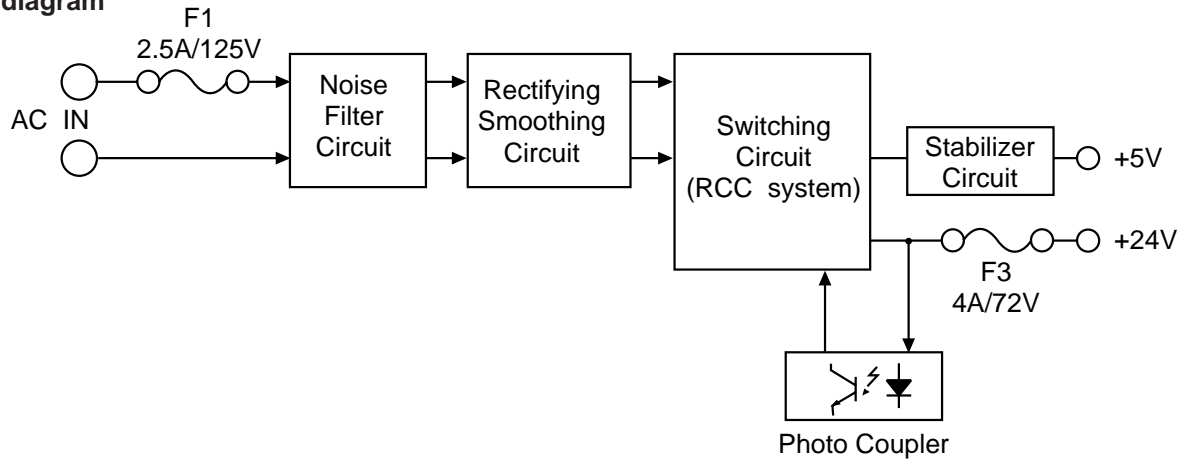

Fig. 8

2-1. Noise filter circuit

The input noise filter section is composed of L and C, which reduces normal mode noise from the AC line and common mode noise to the AC line.

2-2. Rectifying/smoothing circuit

The AC input voltage is rectified by diode D1, 2, 3, 4 and smoothed by capacitor C2 to supply DC voltage to the switching circuit section.

Power thermistor TH1 suppresses inrush current at power switch-on.

2-3. Switching circuit

This circuit employs the self excited ringing choke convertor (RCC) system. In this system, the DC voltage supplied from the rectifying/smoothing section is converted into high frequency pulses by ON/OFF repetition of MOS FET Q1.

Energy is charged in the primary winding of T1 during ON period of Q1, and discharged to the secondary winding during OFF period.

The output voltage is controlled by adjusting ON period of Q1 which changes charge time of C9 through operation of photo-coupler PC1 from +24V output.

The overcurrent protection is performed by bringing Q1 to OFF state through detection of voltage increase in the auxiliary winding of T1 by ZD2, R5 and R6.

2-4. +5V circuit

Each DC voltage supplied by rectifying the output of transformer T1 with diode D9 is stabilized.

[5] Circuit description of CIS unit

1. CIS (Contact Image Sensor)

Cis is an image sensor which puts the original paper in close contact with the full-size sensor for scanning, being a monochromatic type with the pixel number of 1,728 dots and the main scanning density of 8 dots/mm.

It is composed of sensor, rod lens, LED light source, light-conductive plate, control circuit and so on, and the reading line and focus are previously adjusted as the unit.

Due to the full-size sensor, the focus distance is so short that the set is changed from the light weight type to the compact type.

2. Waveforms

The following clock is supplied from FC200 of the control board, and VO is output.

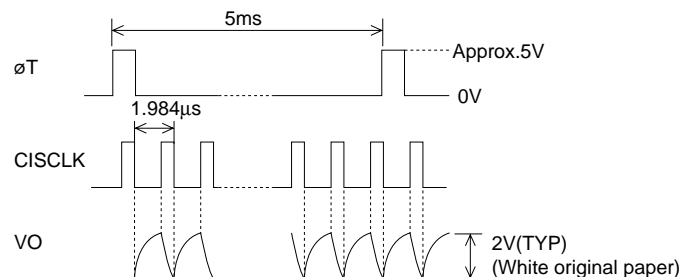
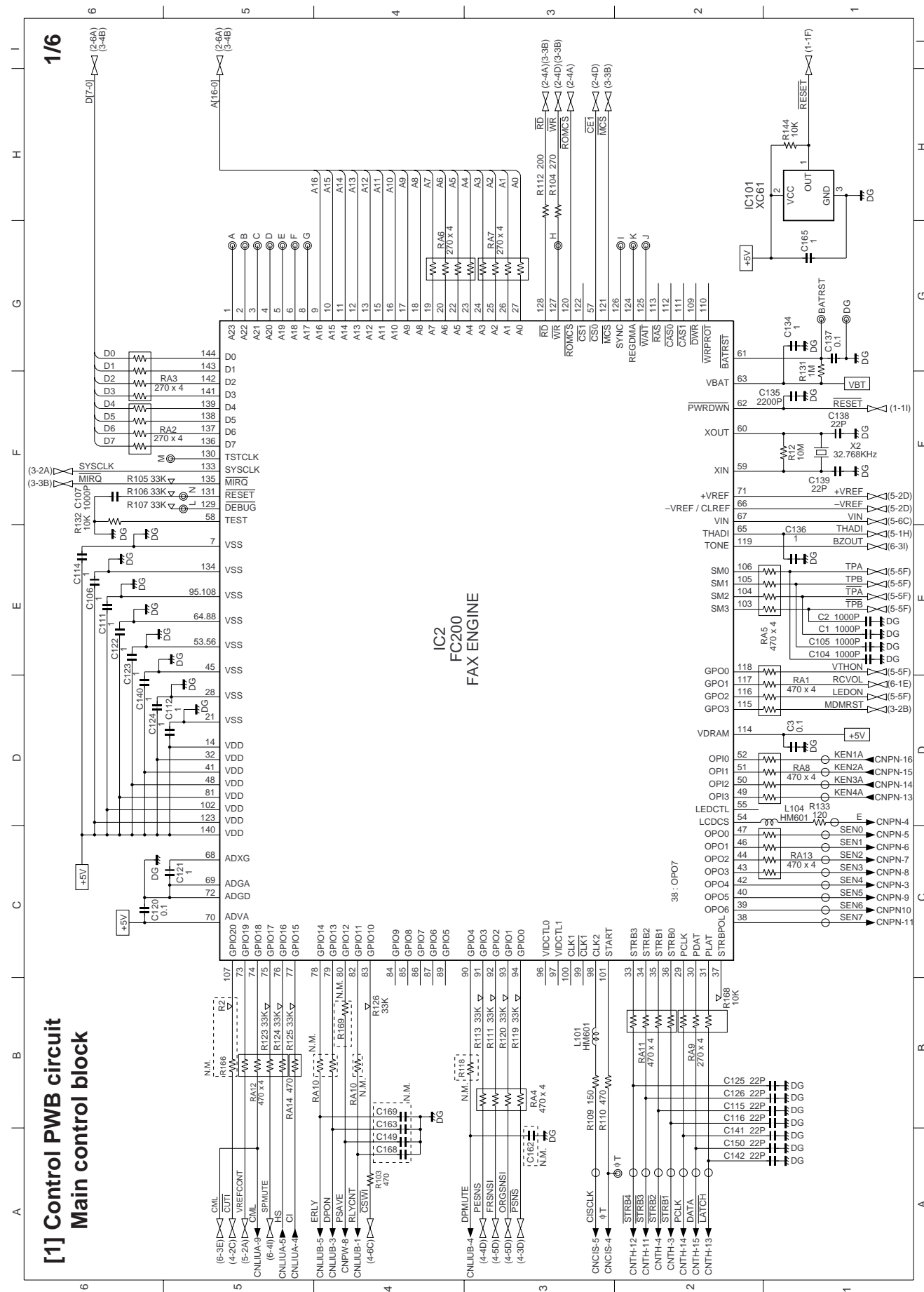

Fig. 9

UX-44U
FO-55C

MEMO

CHAPTER 6. CIRCUIT SCHEMATICS AND PARTS LAYOUT



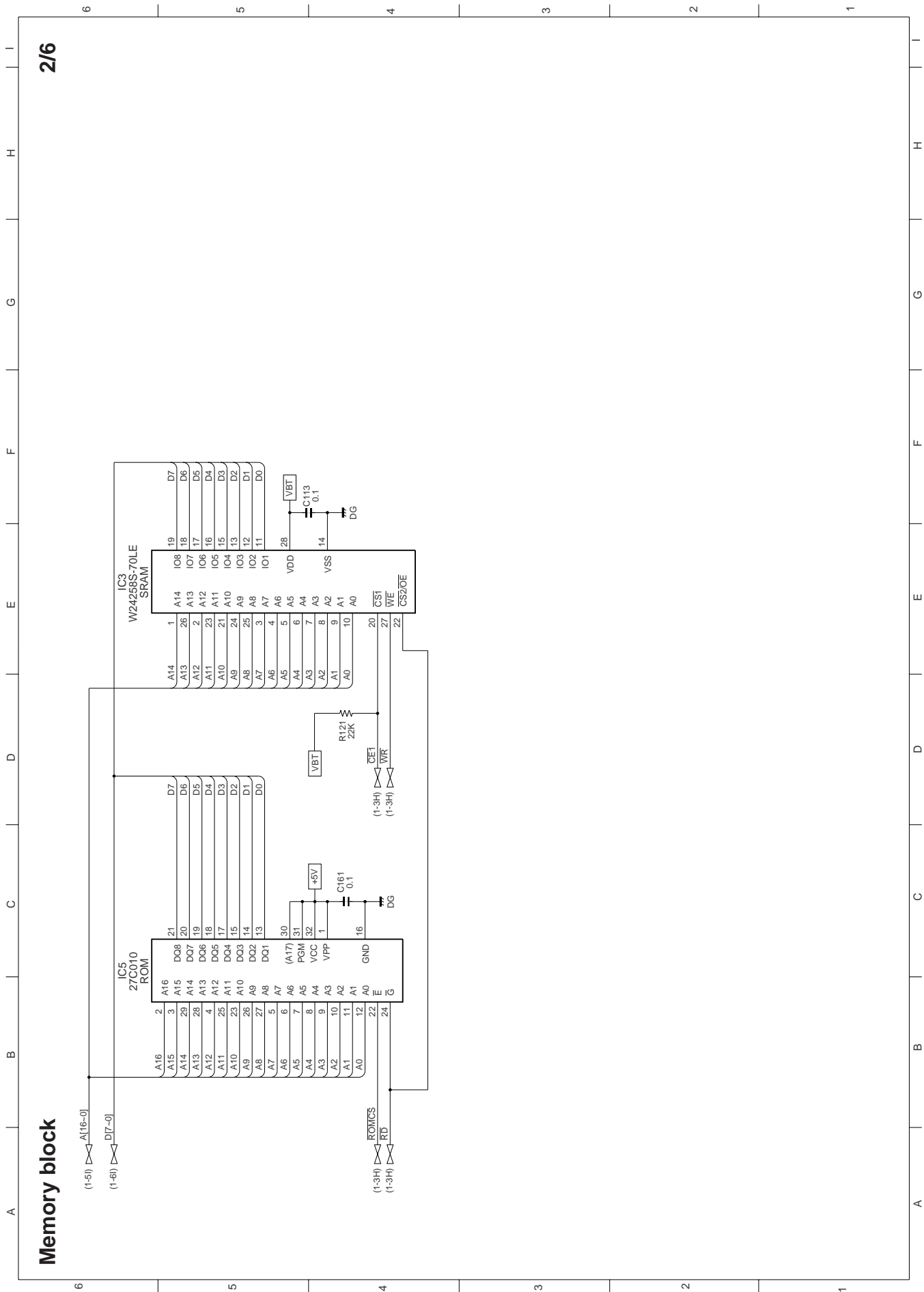

Analog signal block

6/6

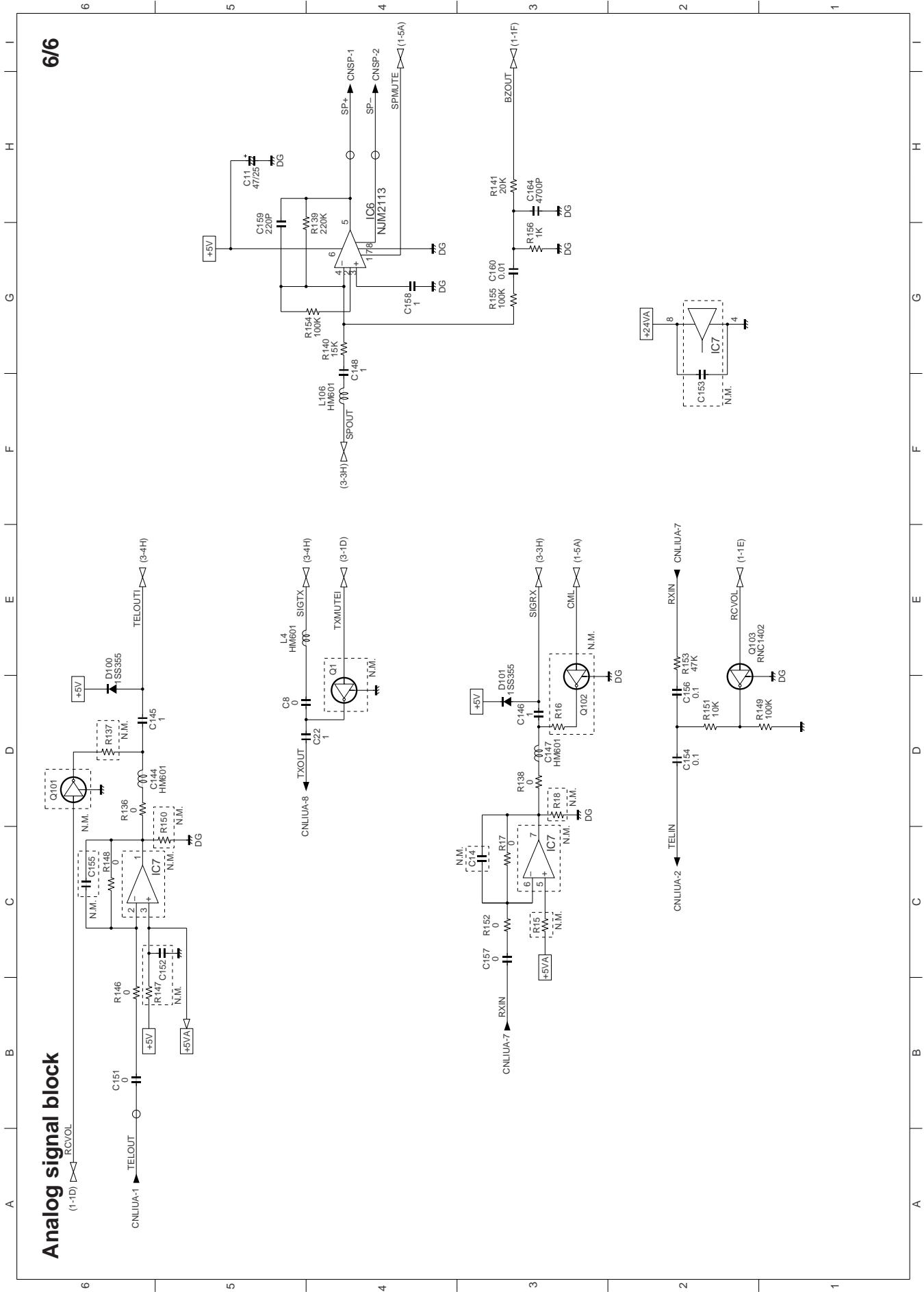

Control PWB parts layout (Top side)

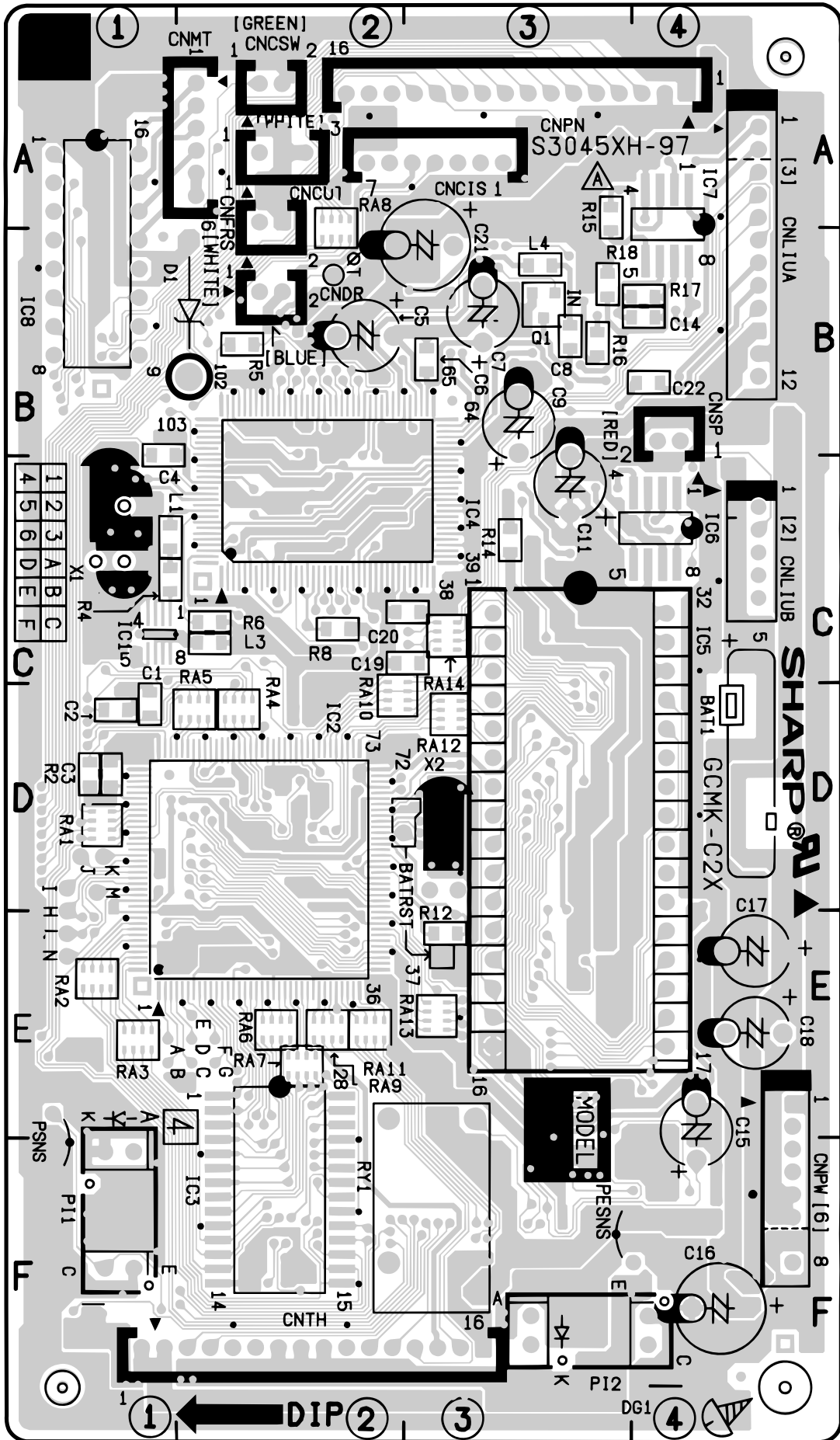

Control PWB parts layout (Bottom side)

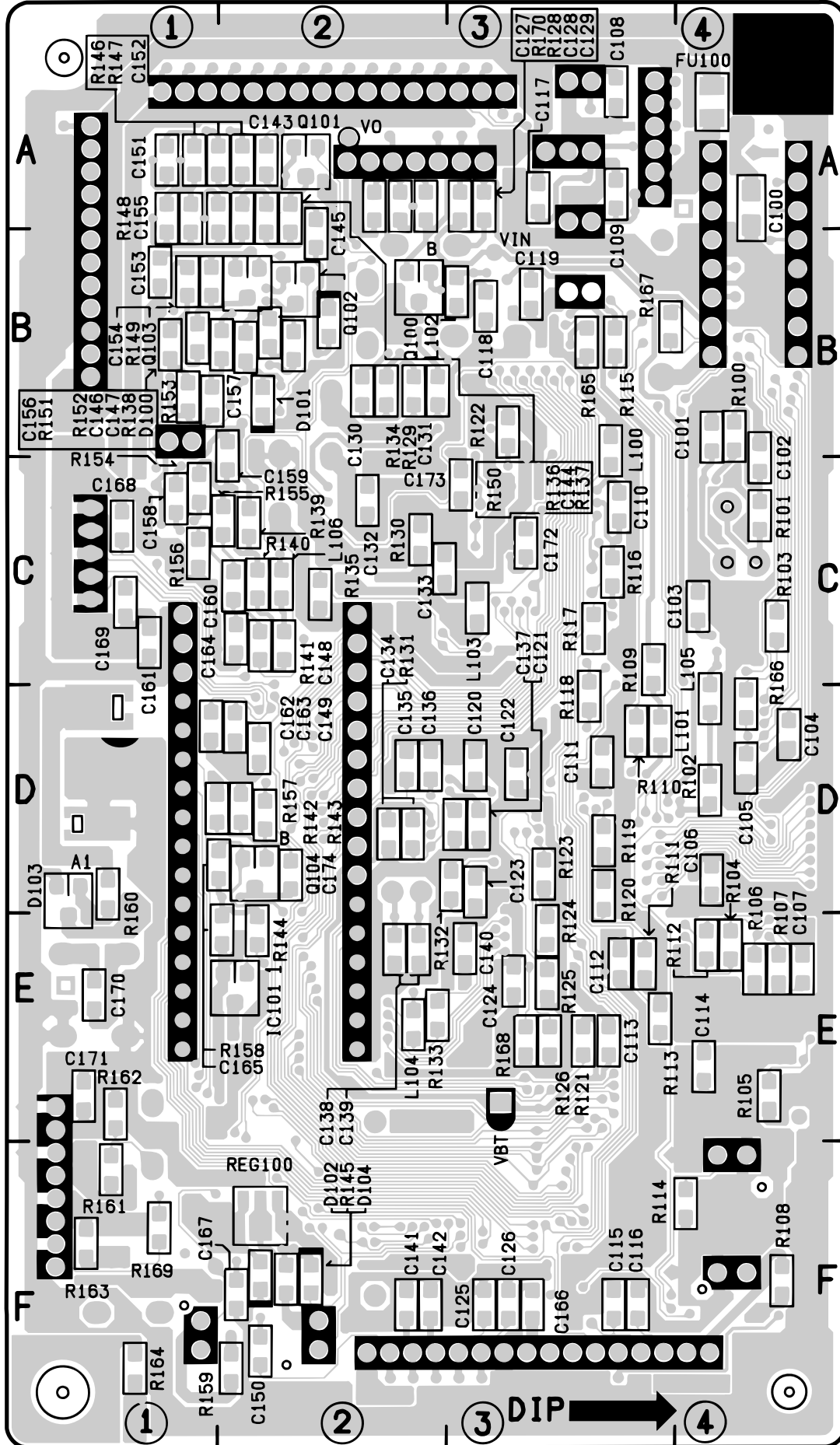

TEL/LIU PWB parts layout (Top side)

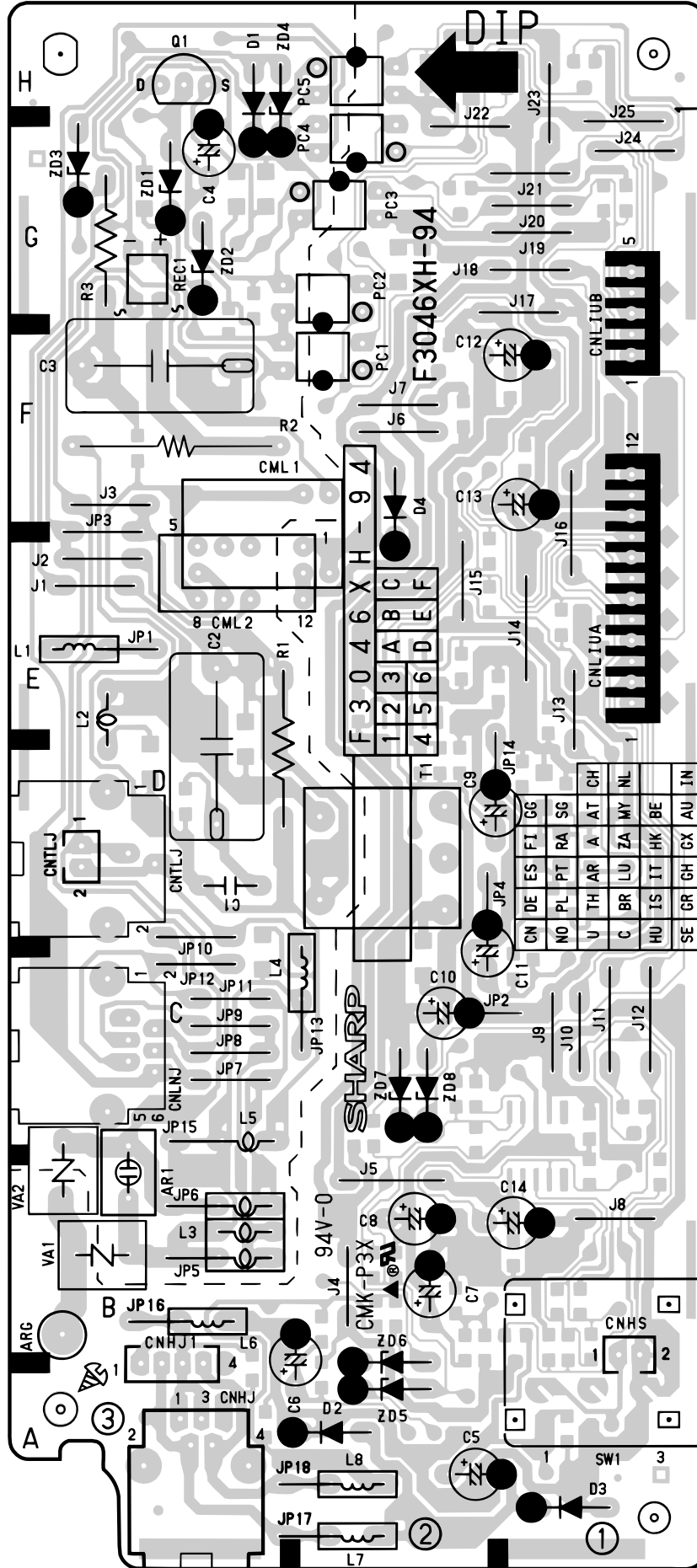

[3] Power supply PWB circuit (RDENT2142XHZZ) (In October, 1999, to the production.)

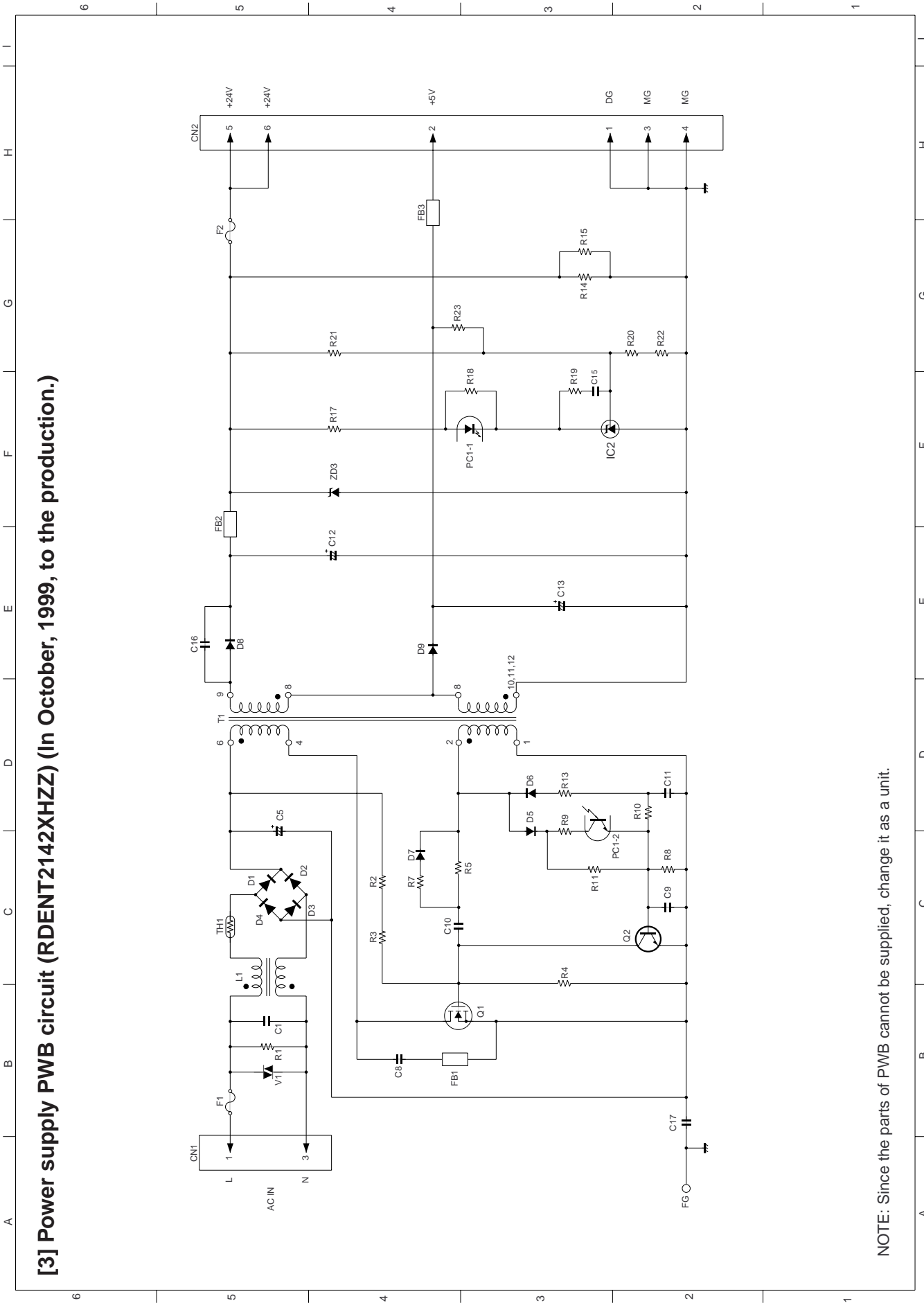

NOTE: Since the parts of PWB cannot be supplied, change it as a unit.

Power supply PWB parts layout (RDENT2142XHZZ) (In October, 1999, to the production.)

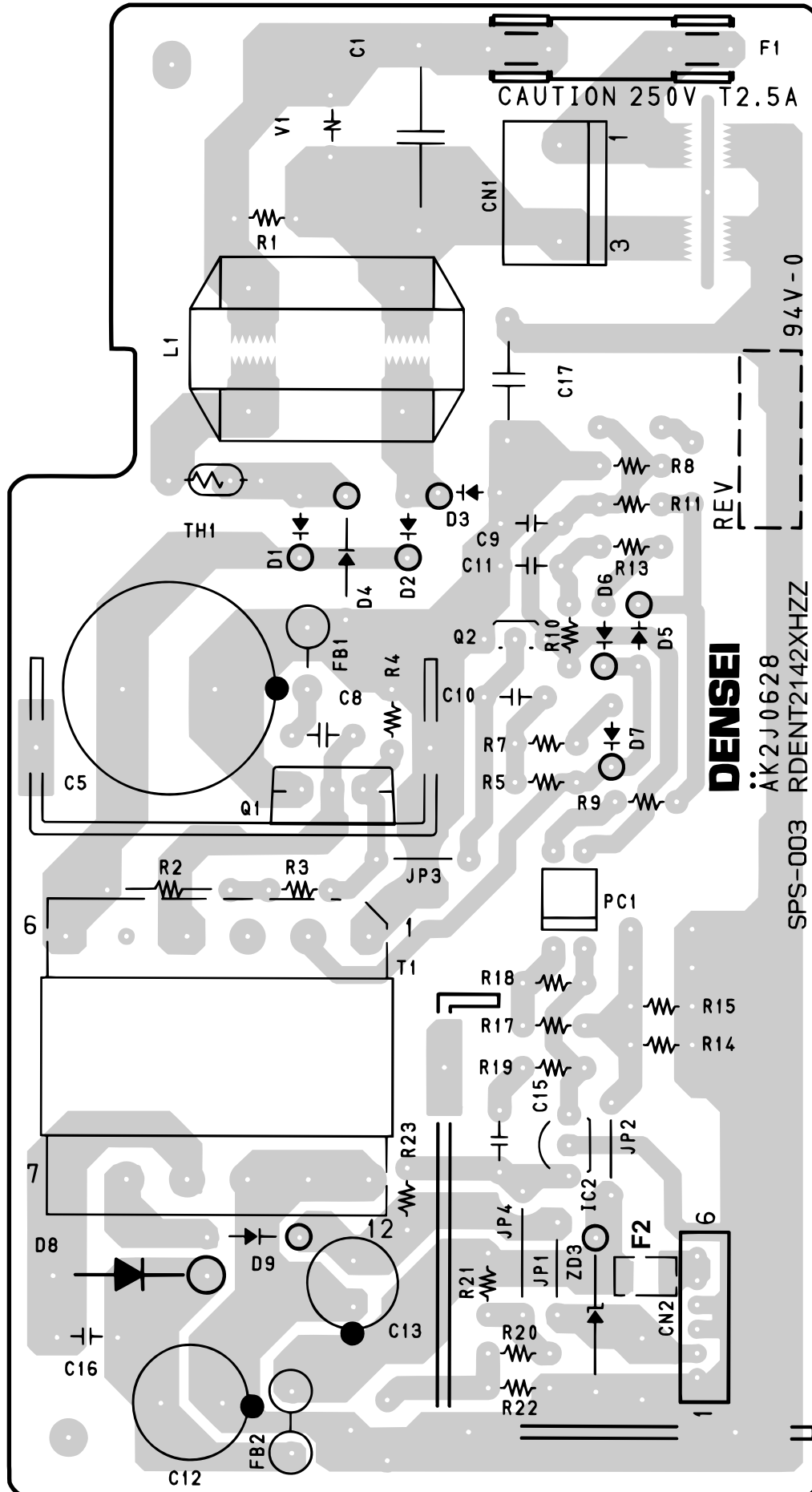

UX-44U
FO-55C

Power supply PWB parts layout (Top side) (RDENT2143XHZZ)
(In November, 1999, than production.)

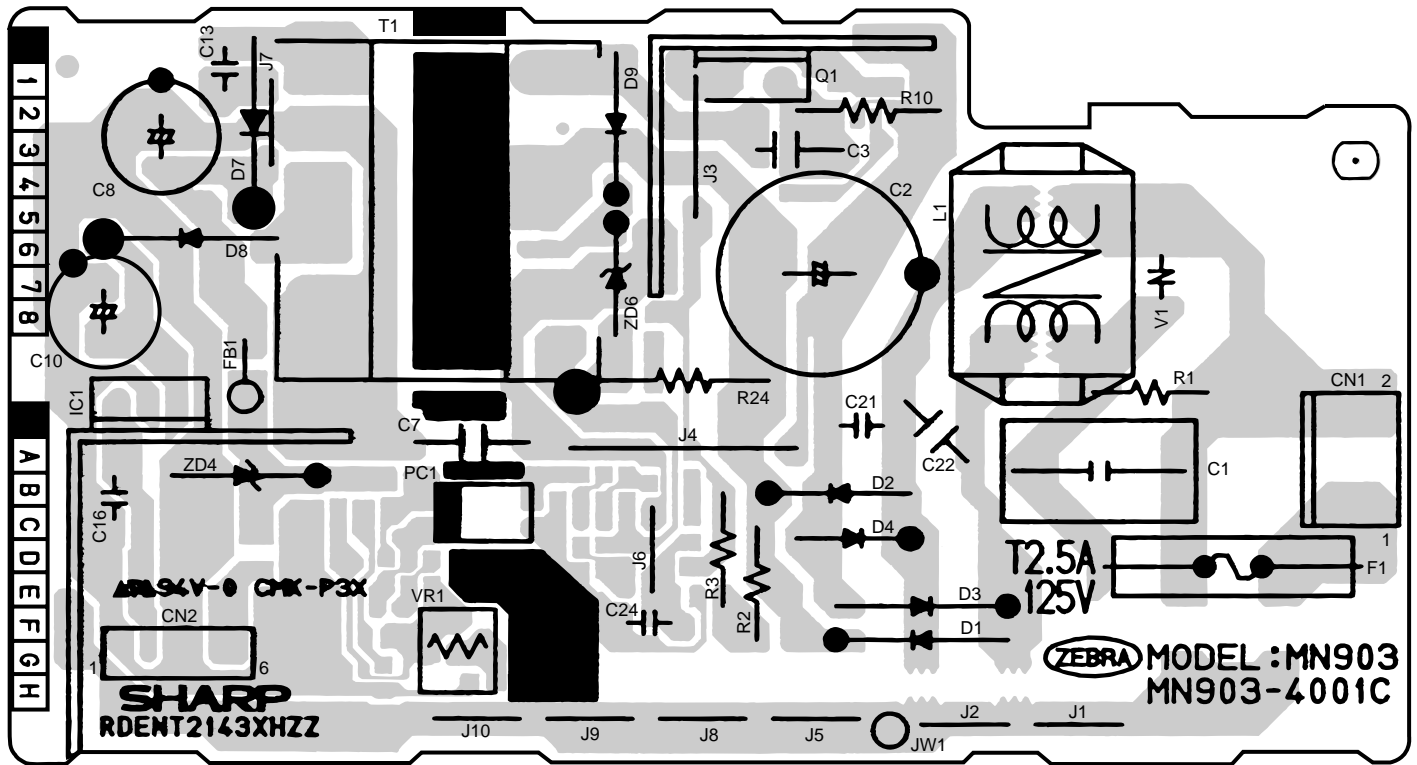

Power supply PWB parts layout (Bottom side) (RDENT2143XHZZ)
(In November, 1999, than production.)

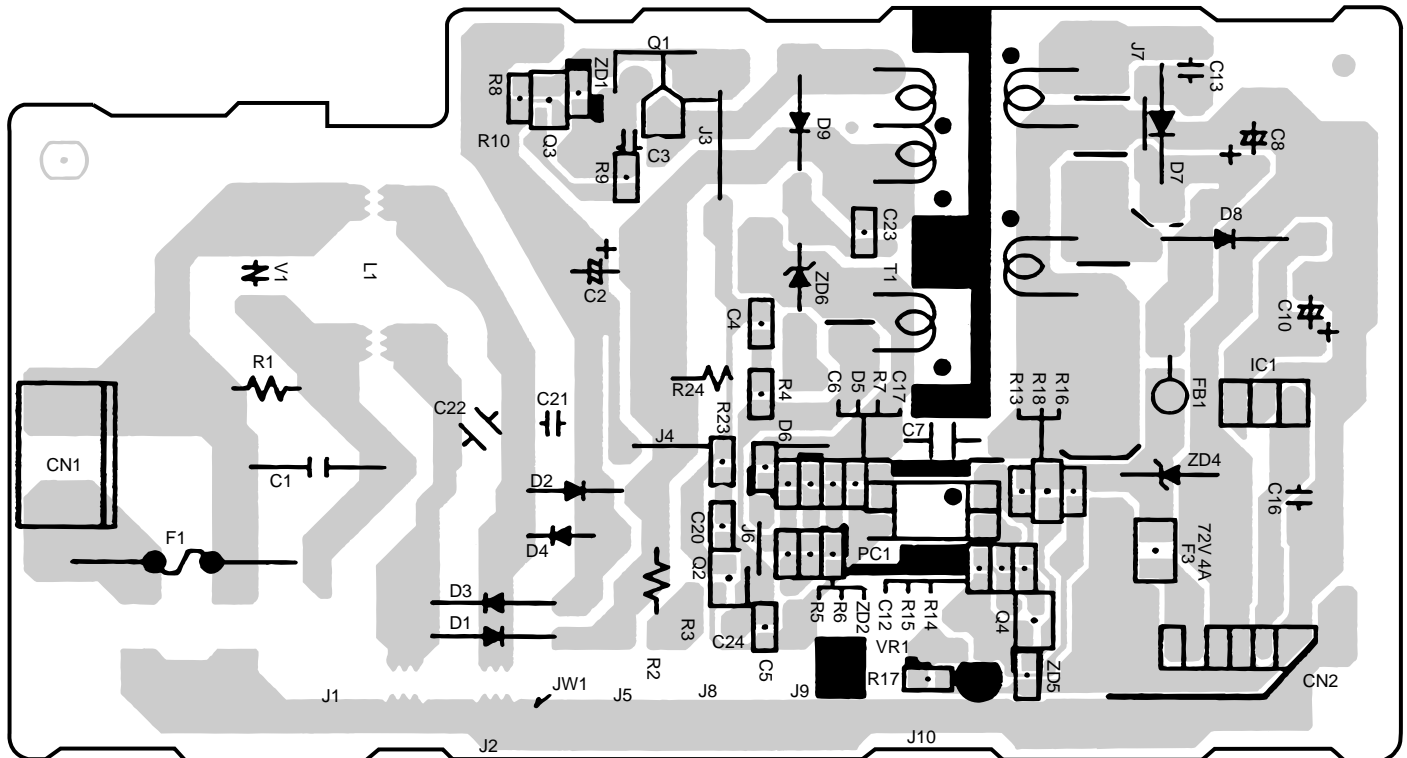

[4] Operation panel PWB circuit

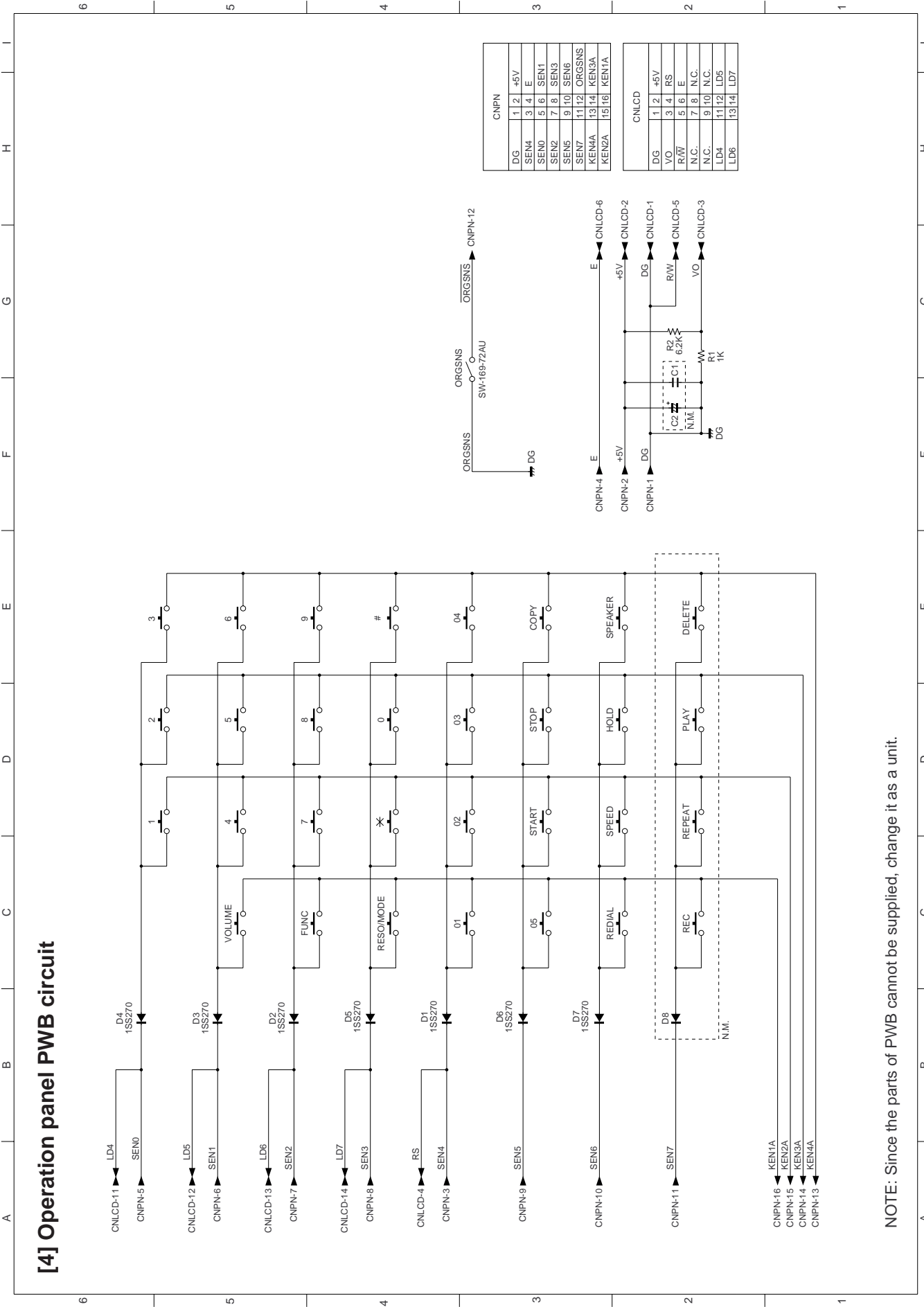

CNPN	
DG	1 2 +5V
SEN4	3 4 E
SEN0	5 6 SEN1
SEN2	7 8 SEN3
SEN5	9 10 SEN6
SEN7	11 12 ORGSNS
KEN14	13 14 KEN3A
KEN2A	15 16 KEN1A

CNLDCD	
DG	1 2 +5V
VO	3 4 RS
R/W	5 6 E
N.C.	7 8 N.C.
N.C.	9 10 N.C.
LD4	11 12 LD5
LD6	13 14 LD7

NOTE: Since the parts of PWB cannot be supplied, change it as a unit.

UX-44U
FO-55C

MEMO

SHARP PARTS GUIDE

UX-44 MODEL FO-55

CONTENTS

- | | |
|------------------------|----------------------------------|
| 1 Cabinet, etc. | 6 Packing material & Accessories |
| 2 Scanner unit | 7 Control PWB unit |
| 3 Upper cabinet | 8 TEL-Liu PWB unit |
| 4 Document guide upper | 9 Power supply PWB unit |
| 5 Drive unit | ■ Index |

Because parts marked with "△" are indispensable for the machine safety maintenance and operation, they must be replaced with the parts specific to the product specification.

[1] Cabinet, etc.

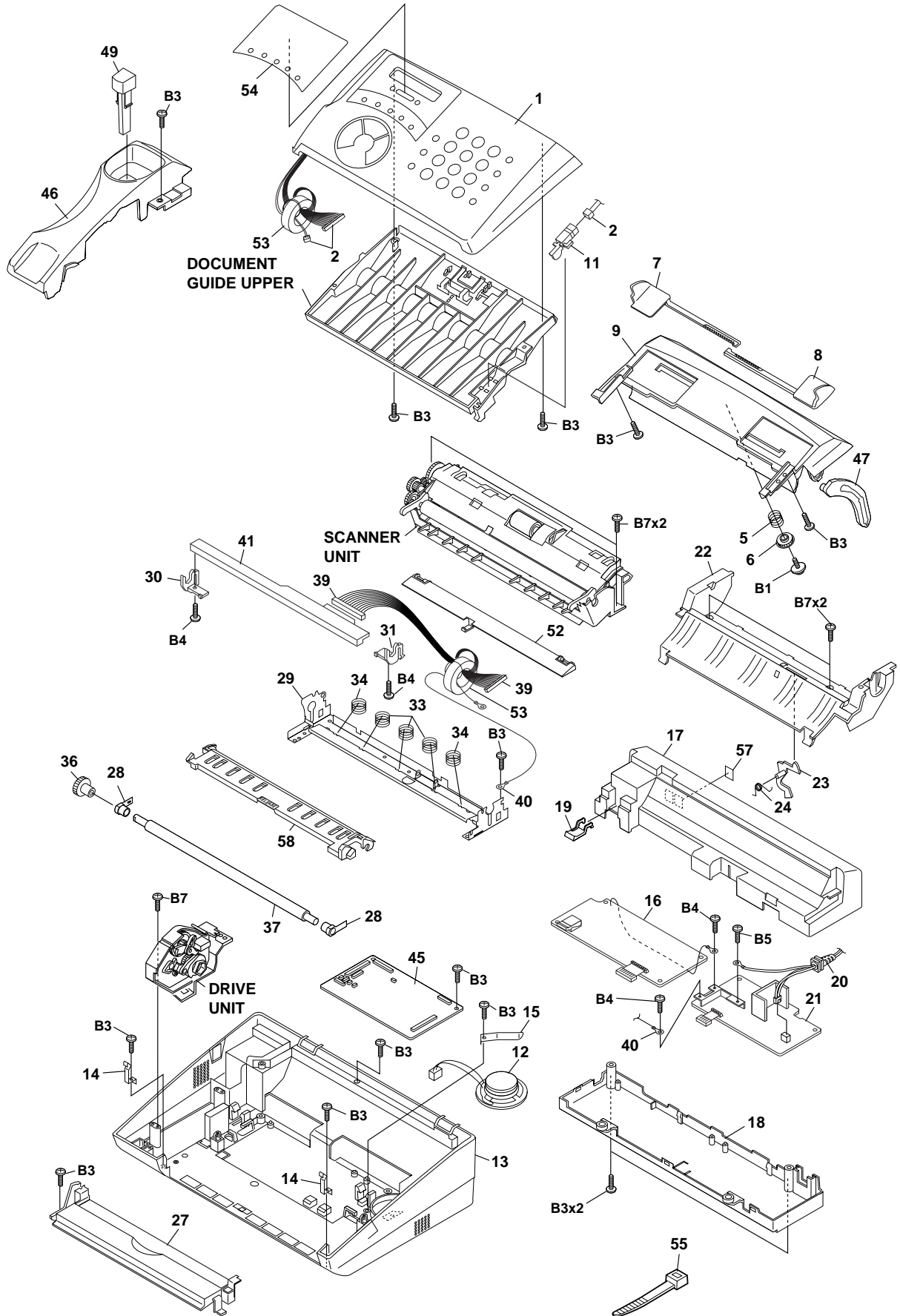

NO.	PARTS CODE	PRICE RANK	NEW MARK	PART RANK	DESCRIPTION
[1] Cabinet etc.					
1	DCEKP481BXH01	AP	N	E	Operation panel unit [44U]
	DCEKP481BXH03	AP	N	E	Operation panel unit [55C]
2	CCNW-212AXH01	AK	N	C	Panel cable ass'y
5	MSPRC2954XHZZ	AC		C	Hopper spring
6	NGERP2318XHZZ	AD		C	Pinion gear
7	PGIDM2560XHSA	AC	N	C	Hopper,guide,left [44U]
	PGIDM2560XHSA	AC	N	C	Hopper,guide,left [55C]
8	PGIDM2561XHSA	AC	N	C	Hopper,guide,right [44U]
	PGIDM2561XHSA	AC	N	C	Hopper,guide,right [55C]
9	PHOP-2104XHSA	AF	N	C	Hopper cover [44U]
	PHOP-2104XHSA	AF	N	C	Hopper cover [55C]
11	QSW-M2296XHZZ	AD		B	Door sensor
12	CCNW-215AXH01	AG	N	C	Speaker ass'y
13	GCABB2343XHSA	AK	N	D	Lower cabinet [44U]
	GCABB2343XHSA	AK	N	D	Lower cabinet [55C]
14	MSPRP3119XHZZ	AC	N	C	Panel lock lever spring
15	MSPRP3123XHZZ	AC	N	C	Speaker holder lever spring
16	DCEKL483BXH01	AX	N	E	TEL/Liu PWB unit [44U]
	DCEKL483BXH08	AX	N	E	TEL/Liu PWB unit [55C]
17	GCASP2110XHSA	AK	N	C	PWB case,top [44U]
	GCASP2110XHSA	AK	N	C	PWB case,top [55C]
18	GCASP2111XHSA	AH	N	C	PWB case,bottom [44U]
	GCASP2111XHSA	AH	N	C	PWB case,bottom [55C]
19	MLEVP2320XHZZ	AC	N	C	Hook switch joint lever
20	QACCD2027XHZZ	AR		B	AC cord ass'y
21	RDENT2142XHZZ	BA		E	Power supply PWB unit(In October, 1999, to the production)
	RDENT2143XHZZ	BA	N	E	Power supply PWB unit(In November, 1999, than production)
22	GDAI-2083XHZZ	AF	N	C	Paper support guide
23	MLEVP2316XHZZ	AC	N	C	Paper sensor lever
24	MSPRD3116XHZZ	AB	N	C	Paper sensor lever spring
27	PGIDM2563XHSA	AE	N	C	PO guide [44U]
	PGIDM2563XHSA	AE	N	C	PO guide [55C]
28	LBSHP2112XHZZ	AB	N	C	Platen bearing
29	LFRM-2208XHZZ	AF	N	C	Head frame
30	LHLDZ2184XHZZ	AC	N	C	Head holder,left
31	LHLDZ2185XHZZ	AC	N	C	Head holder,right
33	MSPRC3112XHZZ	AC	N	C	Head spring 1
34	MSPRC3148XHZZ	AC	N	C	Head spring 2
36	NGERH2478XHZZ	AB	N	C	Platen gear
37	NRRLR2425XHZZ	AP	N	C	Platen roller
39	QCENW-209AXHZZ	AH	N	C	Head cable
40	QCENW-210AXHZZ	AC	N	C	Head earth cable
41	RHEDZ2059XHZZ	BF	N	B	Thermal head
45	DCEKC089MXHZZ	BN	N	E	Control PWB unit(Within ROM)
46	GDAI-2082XHSA	AD	N	C	Handset cover [44U]
	GDAI-2082XHSA	AD	N	C	Handset cover [55C]
47	LSTPP2054XHZZ	AC	N	C	Panel stopper
49	MLEVP2319XHZZ	AC	N	C	Hook switch lever
52	PGIDM2566XHZZ	AC	N	C	Head guide
53	RCORF2125XHZZ	AE		B	Core(TRA31)
54	HPNLH2392XHSC	AE	N	D	Decoration panel [44U]
	HPNLH2392XHSD	AE	N	D	Decoration panel [55C]
55	LBNDJ2006XHZZ	AA		C	Band(100mm)
57	PSHEZ3410XHZZ	AB		C	Jack sheet [55C]
58	MLEVP2321XHZZ	AN	N	C	Release lever
B1	LX-BZ2138XHZZ	AB		C	Screw(2x6)
B3	XEBSD30P08000	AA		C	Screw(3x8)
B4	XBBSD30P06000	AA		C	Screw(3x6)
B5	XBPSN40P06K00	AA		C	Screw(4x6)
B7	XEBSD30P12000	AA		C	Screw(3x12)

[3] Upper cabinet

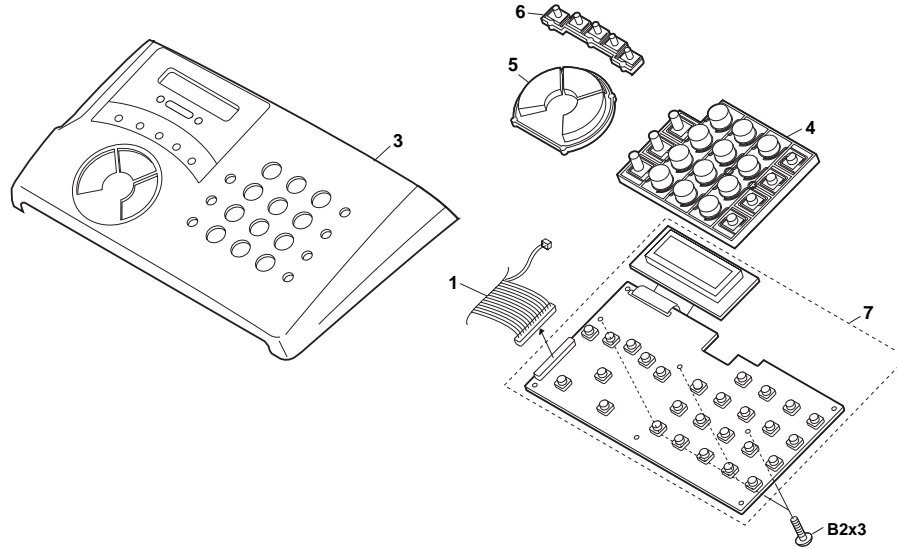

NO.	PARTS CODE	PRICE RANK	NEW MARK	PART RANK	DESCRIPTION
[3] Upper cabinet					
1	CCNW-212AXH01	AK	N	C	Panel cable ass'y
3	GCABA2342XHSA	AH	N	D	Upper cabinet [44U]
	GCABA2342XHSA	AH	N	D	Upper cabinet [55C]
4	JBTN-2257XHSA	AD	N	C	12 key [44U]
	JBTN-2257XHSA	AD	N	C	12 key [55C]
5	JBTN-2258XHSA	AC	N	C	Start key [44U]
	JBTN-2258XHSA	AC	N	C	Start key [55C]
6	JBTN-2261XHSA	AC	N	C	Direct key [44U]
	JBTN-2261XHSA	AC	N	C	Direct key [55C]
7	DCEKP482BXH01	AQ	N	E	Operation panel PWB unit
B2	XUBSD20P06000 (Unit)	AA		C	Screw(2x6)
901	DCEKP481BXH01	AP	N	E	Operation panel unit [44U]
	DCEKP481BXH03	AP	N	E	Operation panel unit [55C]

[4] Document guide upper

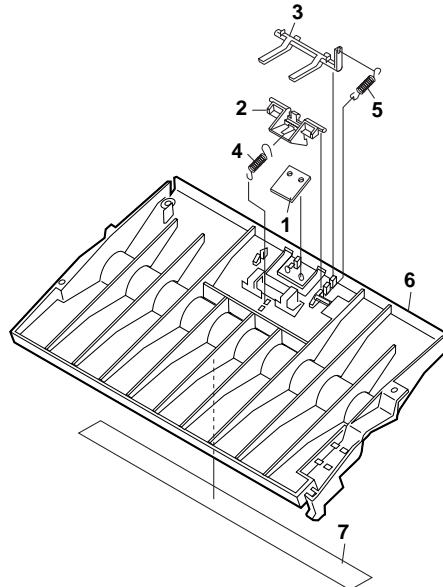

NO.	PARTS CODE	PRICE RANK	NEW MARK	PART RANK	DESCRIPTION
[4] Document guide upper					
1	LPLTG2911XHZZ	AE		C	Separator rubber
2	LPLTP2908XHZZ	AE		C	Separator plate
3	LPLTP3051XHZZ	AB	N	C	Feed plate
4	MSPRT3140XHZZ	AA	N	C	Separate spring
5	MSPRT3139XHZZ	AA	N	C	Feed spring
6	PGIDM2554XHZZ	AF	N	C	Document guide upper
7	PSHEZ3517XHZZ	AE	N	C	Blind sheet

[6] Packing material & Accessories

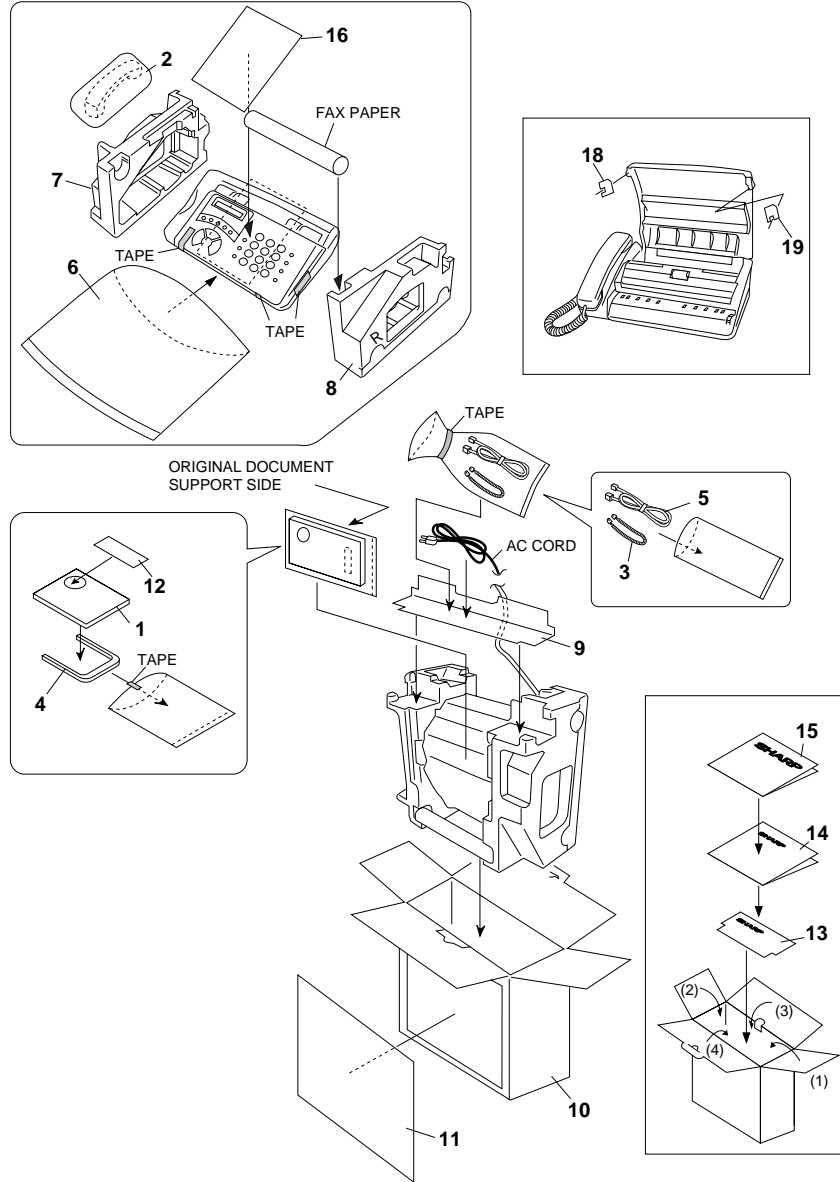

NO.	PARTS CODE	PRICE RANK	NEW MARK	PART RANK	DESCRIPTION
[6] Packing material & Accessories					
1	TINSE4010XHZA	AF	N	D	Operation manual [44U]
	TINSK4065XHZZ	AG	N	D	Operation manual [55C]
2	DUNTK468BXHBG	AH		E	Handset [44U]
	DUNTK468BXHOG	AH	N	E	Handset [55C]
3	QCNW-3976XHBG	AK		C	Handset cord [44U]
	QCNW-3976XHOG	AT		C	Handset cord [55C]
4	PHOP-2105XHZZ	AD	N	C	Original document support
5	QCNW-3975XHGY	AG		C	Telephone line cord [44U]
	QCNW-3247SCZZ	AH		C	Telephone line cord [55C]
6	SPAKP296BXHZZ	AE	N	D	Vinyl cover
7	SPAKA287BXHZZ	AE	N	D	Packing add.,left
8	SPAKA288BXHZZ	AE	N	D	Packing add.,right
9	SPAKA289BXHZZ	AC	N	D	Pad
10	SPAKC142BXHZZ	AH	N	D	Packing case [44U]
	SPAKC254BXHZZ	AH	N	D	Packing case [55C]
11	TLABM270AXHZZ	AD	N	D	Box label [44U]
	TLABM458AXHZZ	AD	N	D	Box label [55C]
12	TLABH418AXHZZ	AC		D	Service call label [44U]
13	TCADZ2861XHZZ	AD	N	D	Pop card [44U]
	TCADZ2913XHZZ	AD	N	D	Pop card [55C]
14	TCADZ2869XHZZ	AB		D	Quick setup guide [44U]
15	TCADZ2786XHZZ	AC		D	Read me first sheet [44U]
16	TCADZ2935XHZZ	AA	N	D	Caution sheet
18	SPAKA388BXHZZ	AE	N	D	Protection sheet,left
19	SPAKA389BXHZZ	AE	N	D	Protection sheet,right

NO.	PARTS CODE	PRICE RANK	NEW MARK	PART RANK	DESCRIPTION
[7] Control PWB unit					
1	UBATL2046SCZZ	AK		B	Battery(CR2032T34) [BAT1]
2	VCKYTV1HB102K	AA		C	Capacitor(50WV 1000PF) [C1]
3	VCKYTV1HB102K	AA		C	Capacitor(50WV 1000PF) [C2]
4	VCKYTV1EF104Z	AA		C	Capacitor(25WV 0.1μF) [C3]
5	VCKYTV1HB103K	AB		C	Capacitor(50WV 0.01μF) [C4]
6	VCEAGA1HW106M	AA		C	Capacitor(50WV 10μF) [C5]
7	VCKYTV1EF104Z	AA		C	Capacitor(25WV 0.1μF) [C6]
8	VCEAGA1HW106M	AA		C	Capacitor(50WV 10μF) [C7]
9	VRS-TS2AD000J	AA		C	Resistor(1/10W 0Ω ±5%) [C8]
10	VCEAGA1EW476M	AA		C	Capacitor(25WV 47μF) [C9]
11	VCEAGA1EW476M	AA		C	Capacitor(25WV 47μF) [C11]
12	VCEAGA1HW106M	AA		C	Capacitor(50WV 10μF) [C15]
13	VCEAGA1HW226M	AB		C	Capacitor(50WV 22μF) [C17]
14	VCEAGA1EW476M	AA		C	Capacitor(25WV 47μF) [C18]
15	VCKYTV1HB102K	AA		C	Capacitor(50WV 1000PF) [C19]
16	VCKYTV1HB102K	AA		C	Capacitor(50WV 1000PF) [C20]
17	VCEAGA1HW107M	AA		C	Capacitor(50WV 100μF) [C21]
18	VCKYTV1CF105Z	AB		C	Capacitor(16WV 1μF) [C22]
19	VCKYTV1HF104Z	AA		C	Capacitor(50WV 0.1μF) [C100]
20	VCCCTV1HH120J	AA		C	Capacitor(50WV 12PF) [C101]
21	VCCCTV1HH120J	AA		C	Capacitor(50WV 12PF) [C102]
22	VCKYTV1CF105Z	AB		C	Capacitor(16WV 1μF) [C103]
23	VCKYTV1HB102K	AA		C	Capacitor(50WV 1000PF) [C104]
24	VCKYTV1HB102K	AA		C	Capacitor(50WV 1000PF) [C105]
25	VCKYTV1CF105Z	AB		C	Capacitor(16WV 1μF) [C106]
26	VCKYTV1HB102K	AA		C	Capacitor(50WV 1000PF) [C107]
27	VCKYTV1HB222K	AA		C	Capacitor(50WV 2200PF) [C108]
28	VCKYTV1HB222K	AA		C	Capacitor(50WV 2200PF) [C109]
29	VCKYTV1EF104Z	AA		C	Capacitor(25WV 0.1μF) [C110]
30	VCKYTV1CF105Z	AB		C	Capacitor(16WV 1μF) [C111]
31	VCKYTV1CF105Z	AB		C	Capacitor(16WV 1μF) [C112]
32	VCKYTV1EF104Z	AA		C	Capacitor(25WV 0.1μF) [C113]
33	VCKYTV1CF105Z	AB		C	Capacitor(16WV 1μF) [C114]
34	VCCCTV1HH220J	AA		C	Capacitor(50WV 22PF) [C115]
35	VCCCTV1HH220J	AA		C	Capacitor(50WV 22PF) [C116]
36	VCKYTV1EF104Z	AA		C	Capacitor(25WV 0.1μF) [C118]
37	VCKYTV1HB222K	AA		C	Capacitor(50WV 2200PF) [C119]
38	VCKYTV1EF104Z	AA		C	Capacitor(25WV 0.1μF) [C120]
39	VCKYTV1CF105Z	AB		C	Capacitor(16WV 1μF) [C121]
40	VCKYTV1CF105Z	AB		C	Capacitor(16WV 1μF) [C122]
41	VCKYTV1CF105Z	AB		C	Capacitor(16WV 1μF) [C123]
42	VCKYTV1CF105Z	AB		C	Capacitor(16WV 1μF) [C124]
43	VCCCTV1HH220J	AA		C	Capacitor(50WV 22PF) [C125]
44	VCCCTV1HH220J	AA		C	Capacitor(50WV 22PF) [C126]
45	VCKYTV1CF105Z	AB		C	Capacitor(16WV 1μF) [C127]
46	VCKYTV1HB102K	AA		C	Capacitor(50WV 1000PF) [C128]
47	VCKYTV1EF104Z	AA		C	Capacitor(25WV 0.1μF) [C129]
48	VCKYTV1EB104K	AA		C	Capacitor(25WV 0.1μF) [C130]
49	VCKYTV1EF104Z	AA		C	Capacitor(25WV 0.1μF) [C131]
50	VCKYTV1CF105Z	AB		C	Capacitor(16WV 1μF) [C132]
51	VCKYTV1CF105Z	AB		C	Capacitor(16WV 1μF) [C133]
52	VCKYTV1CF105Z	AB		C	Capacitor(16WV 1μF) [C134]
53	VCKYTV1HB222K	AA		C	Capacitor(50WV 2200PF) [C135]
54	VCKYTV1CF105Z	AB		C	Capacitor(16WV 1μF) [C136]
55	VCKYTV1EF104Z	AA		C	Capacitor(25WV 0.1μF) [C137]
56	VCCCTV1HH220J	AA		C	Capacitor(50WV 22PF) [C138]
57	VCCCTV1HH220J	AA		C	Capacitor(50WV 22PF) [C139]
58	VCKYTV1CF105Z	AB		C	Capacitor(16WV 1μF) [C140]
59	VCCCTV1HH220J	AA		C	Capacitor(50WV 22PF) [C141]
60	VCCCTV1HH220J	AA		C	Capacitor(50WV 22PF) [C142]
61	VCKYTV1HB222K	AA		C	Capacitor(50WV 2200PF) [C143]
62	RCILZ2145XHZZ	AF		C	Coil(HM601) [C144]
63	VCKYTV1CF105Z	AB		C	Capacitor(16WV 1μF) [C145]
64	VCKYTV1CF105Z	AB		C	Capacitor(16WV 1μF) [C146]
65	RCILZ2145XHZZ	AF		C	Coil(HM601) [C147]
66	VCKYTV1CF105Z	AB		C	Capacitor(16WV 1μF) [C148]
67	VCCCTV1HH220J	AA		C	Capacitor(50WV 22PF) [C150]
68	VRS-TS2AD000J	AA		C	Resistor(1/10W 0Ω ±5%) [C151]
69	VCKYTV1EB104K	AA		C	Capacitor(25WV 0.1μF) [C154]
70	VCKYTV1EB104K	AA		C	Capacitor(25WV 0.1μF) [C156]
71	VRS-TS2AD000J	AA		C	Resistor(1/10W 0Ω ±5%) [C157]
72	VCKYTV1CF105Z	AB		C	Capacitor(16WV 1μF) [C158]
73	VCKYTV1HB221K	AA		C	Capacitor(50WV 220PF) [C159]
74	VCKYTV1HB103K	AB		C	Capacitor(50WV 0.01μF) [C160]
75	VCKYTV1EF104Z	AA		C	Capacitor(25WV 0.1μF) [C161]
76	VCKYTV1HB472K	AA		C	Capacitor(50WV 4700PF) [C164]
77	VCKYTV1CF105Z	AB		C	Capacitor(16WV 1μF) [C165]
78	VCKYTV1CF105Z	AB		C	Capacitor(16WV 1μF) [C166]
79	VCKYTV1EF104Z	AA		C	Capacitor(25WV 0.1μF) [C167]
80	VCKYTV1HF104Z	AA		C	Capacitor(50WV 0.1μF) [C170]

NO.	PARTS CODE	PRICE RANK	NEW MARK	PART RANK	DESCRIPTION	
[7] Control PWB unit						
81	VCKYTV1EF104Z	AA		C	Capacitor(25WV 0.1μF)	[C171]
82	VCKYTV1HB102K	AA		C	Capacitor(50WV 1000PF)	[C172]
83	VCKYTV1HB102K	AA		C	Capacitor(50WV 1000PF)	[C173]
84	QCNCM7014SC0G	AB		C	Connector(7pin)	[CNCIS]
85	QCNCM2442SC0B	AB		C	Conector(2pin)	[CNCISW]
86	QCNCM705BAF06	AB		C	Connector(2pin)	[CNDR]
87	QCNCM7014SC0B	AD		C	Connector(2pin)	[CNFRS]
88	QCNCW2500SC1B	AF		C	Connector(12pin)	[CNLIUA]
89	QCNCM7014SC0F	AB		C	Connector(6pin)	[CNMT]
90	QCNCM7014SC1F	AD		C	Connector(16pin)	[CNPJN]
91	QCNCW2500SC0F	AE		C	Connector(6pin)	[CNPW]
92	QCNCM2401SC0B	AA		C	Connector(2pin)	[CNSP]
93	QCNCM7014SC1F	AD		C	Connector(16pin)	[CNTH]
94	VRS-HT3AA101J	AA		C	Resistor(1W 100Ω ±5%)	[D1]
95	VHD1SS355/-1	AB		B	Diode(1SS355)	[D100]
96	VHD1SS355/-1	AB		B	Diode(1SS355)	[D101]
97	VHD1SS355/-1	AB		B	Diode(1SS355)	[D102]
98	VHDHRW0202B-1	AD		B	Diode(HRW0202B)	[D103]
99	VHD1SS355/-1	AB		B	Diode(1SS355)	[D104]
100	QFS-P2010SCZZ	AD	N	B	IC protector(KAB2402)	[FU100]
101	VHITC7WT74FU1	AF	N	B	IC(TC7WT74)	[IC1]
102	VHIFC2FM209-1	BD	N	B	IC(FC200)(Within IC2 and IC4 pair)	[IC2]
103	VHIW24258S7LE	AQ		B	IC(W24258S-70LE)	[IC3]
104	VHIFC2FM209-1	BD	N	B	IC(FM209)(Within IC2 and IC4 pair)	[IC4]
105	QSOCZ2051SC32	AC		C	IC socket(32pin)	[IC5]
	VHI27010FZF0C	BM	N	B	IC,EPROM(1MB)	[IC5]
107	VHINJM2113M-1	AG		B	IC(NJM2113M)	[IC6]
108	VHIULN2003AN/	AE		B	IC(ULN2003ANS)	[IC8]
109	VHIXC61AN45M1	AE	N	B	IC(XC61AN4502ML)	[IC101]
110	RCILZ2145XHZZ	AF		C	Coil(HM601)	[L1]
111	RCILZ2145XHZZ	AF		C	Coil(HM601)	[L3]
112	RCILZ2145XHZZ	AF		C	Coil(HM601)	[L4]
113	RCILZ2145XHZZ	AF		C	Coil(HM601)	[L100]
114	RCILZ2145XHZZ	AF		C	Coil(HM601)	[L101]
115	RCILZ2145XHZZ	AF		C	Coil(HM601)	[L102]
116	RCILZ2145XHZZ	AF		C	Coil(HM601)	[L103]
117	RCILZ2145XHZZ	AF		C	Coil(HM601)	[L104]
118	RCILZ2145XHZZ	AF		C	Coil(HM601)	[L105]
119	RCILZ2145XHZZ	AF		C	Coil(HM601)	[L106]
120	VHPSG206S/-1	AG		B	Photo transistor(SG206S)	[PI2]
121	VS2SA1037KS-1	AB		B	Transistor(2SA1037KS)	[Q100]
122	VSRNC1402/-1	AC		B	Transistor(RNC1402)	[Q103]
123	VS2SA1037KS-1	AB		B	Transistor(2SA1037KS)	[Q104]
124	VRS-TS2AD271J	AA		C	Resistor(1/10W 270Ω ±5%)	[R4]
125	VRS-TS2AD333J	AA		C	Resistor(1/10W 33KΩ ±5%)	[R6]
126	VRS-TS2AD103J	AA		C	Resistor(1/10W 10KΩ ±5%)	[R8]
127	VRS-TS2AD106J	AA		C	Resistor(1/10W 10MΩ ±5%)	[R12]
128	VRS-TS2AD3R0J	AA		C	Resistor(1/10W 3.0Ω ±5%)	[R14]
129	VRS-TS2AD000J	AA		C	Resistor(1/10W 0Ω ±5%)	[R17]
130	VRS-TS2AD201J	AG		C	Resistor(1/10W 200Ω ±5%)	[R100]
131	VRS-TS2AD000J	AA		C	Resistor(1/10W 0Ω ±5%)	[R101]
132	VRS-TS2AD471J	AA		C	Resistor(1/10W 470Ω ±5%)	[R102]
133	VRS-TS2AD471J	AA		C	Resistor(1/10W 470Ω ±5%)	[R103]
134	VRS-TS2AD271J	AA		C	Resistor(1/10W 270Ω ±5%)	[R104]
135	VRS-TS2AD333J	AA		C	Resistor(1/10W 33KΩ ±5%)	[R105]
136	VRS-TS2AD333J	AA		C	Resistor(1/10W 33KΩ ±5%)	[R106]
137	VRS-TS2AD333J	AA		C	Resistor(1/10W 33KΩ ±5%)	[R107]
138	VRS-TS2AD223J	AA		C	Resistor(1/10W 22KΩ ±5%)	[R108]
139	VRS-TS2AD151J	AA		C	Resistor(1/10W 150Ω ±5%)	[R109]
140	VRS-TS2AD471J	AA		C	Resistor(1/10W 470Ω ±5%)	[R110]
141	VRS-TS2AD333J	AA		C	Resistor(1/10W 33KΩ ±5%)	[R111]
142	VRS-TS2AD201J	AG		C	Resistor(1/10W 200Ω ±5%)	[R112]
143	VRS-TS2AD333J	AA		C	Resistor(1/10W 33KΩ ±5%)	[R113]
144	VRS-TS2AD000J	AA		C	Resistor(1/10W 0Ω ±5%)	[R114]
145	VRS-TS2AD471J	AA		C	Resistor(1/10W 470Ω ±5%)	[R115]
146	VRS-TS2AD471J	AA		C	Resistor(1/10W 470Ω ±5%)	[R117]
147	VRS-TS2AD333J	AA		C	Resistor(1/10W 33KΩ ±5%)	[R119]
148	VRS-TS2AD333J	AA		C	Resistor(1/10W 33KΩ ±5%)	[R120]
149	VRS-TS2AD223J	AA		C	Resistor(1/10W 22KΩ ±5%)	[R121]
150	VRS-TS2AD103J	AA		C	Resistor(1/10W 10KΩ ±5%)	[R122]
151	VRS-TS2AD333J	AA		C	Resistor(1/10W 33KΩ ±5%)	[R123]
152	VRS-TS2AD333J	AA		C	Resistor(1/10W 33KΩ ±5%)	[R124]
153	VRS-TS2AD333J	AA		C	Resistor(1/10W 33KΩ ±5%)	[R125]
154	VRS-TS2AD333J	AA		C	Resistor(1/10W 33KΩ ±5%)	[R126]
155	VRS-TS2AD512J	AA		C	Resistor(1/10W 5.1KΩ ±5%)	[R128]
156	VRS-TS2AD102J	AA		C	Resistor(1/10W 1KΩ ±5%)	[R129]
157	VRS-TS2AD000J	AA		C	Resistor(1/10W 0Ω ±5%)	[R130]
158	VRS-TS2AD105J	AA		C	Resistor(1/10W 1.0MΩ ±5%)	[R131]
159	VRS-TS2AD103J	AA		C	Resistor(1/10W 10KΩ ±5%)	[R132]
160	VRS-TS2AD121J	AA		C	Resistor(1/10W 120Ω ±5%)	[R133]

NO.	PARTS CODE	PRICE RANK	NEW MARK	PART RANK	DESCRIPTION
[8] TEL/Liu PWB unit					
27	VCKYTV1HB393K	AB		C	Capacitor(50WV 0.039μF) [C127]
28	RRLYD3433XHZZ	AH		B	Relay [CML1]
29	QJAKZ2079XH0D	AD	N	C	Jack [CNHJ]
30	QCNCM2548SC1B	AH		C	Connector(12pin) [CNLIUA]
31	QJAKZ2060SC0B	AD		C	Jack [CNLNJ]
32	QJAKZ2060SC0B	AD		C	Jack [CNTLJ][55C]
33	VHDDSS133//1	AA		B	Diode(1SS133) [D1]
34	VHDDSS133//1	AA		B	Diode(1SS133) [D4]
35	QSW-Z2263XHZZ	AG		B	Hook switch [HOOK SW]
36	VHINJM2904M-2	AG		B	IC(NJM2904M) [IC101]
37	VHINJM2904M-2	AG		B	IC(NJM2904M) [IC102]
38	RFILN2024XHZZ	AG		C	Coil(TR0703) [L3A]
39	RFILN2024XHZZ	AG		C	Coil(TR0703) [L3B]
40	RFILN2024XHZZ	AG		C	Coil(TR0703) [L6]
41	RFILN2024XHZZ	AG		C	Coil(TR0703) [L7]
42	RFILN2024XHZZ	AG		C	Coil(TR0703) [L8]
43	VHPTLP521-1BL	AE		B	Photo coupler(TLP521) [PC5]
44	VS2SC2412KR-1	AD		B	Transistor(2SC2412K) [Q101]
45	VSRNC1402//1	AC		B	Transistor(RNC1402) [Q104]
46	VSRNC1402//1	AC		B	Transistor(RNC1402) [Q107]
47	VRD-HT2HY223J	AA		C	Resistor(1/2W 22KΩ ±5%) [R3]
48	VRS-TS2AD223J	AA		C	Resistor(1/10W 22KΩ ±5%) [R101]
49	VRS-TS2AD152J	AA		C	Resistor(1/10W 1.5KΩ ±5%) [R108]
50	VRS-TS2AD102J	AA		C	Resistor(1/10W 1KΩ ±5%) [R109]
51	VRS-TS2AD512J	AA		C	Resistor(1/10W 5.1KΩ ±5%) [R110]
52	VRS-TS2AD203J	AA		C	Resistor(1/10W 20KΩ ±5%) [R111]
53	VRS-TS2AD000J	AA		C	Resistor(1/10W 0Ω ±5%) [R112]
54	VRS-TS2AD203J	AA		C	Resistor(1/10W 20KΩ ±5%) [R113]
55	VRS-TS2AD433J	AA		C	Resistor(1/10W 43KΩ ±5%) [R114]
56	VRSTS2AD8662F	AA		C	Resistor(1/10W 86.6KΩ ±1%) [R115]
57	VRS-TS2AD332J	AA		C	Resistor(1/10W 3.3KΩ ±5%) [R116]
58	VRS-TS2AD102J	AA		C	Resistor(1/10W 1KΩ ±5%) [R118]
59	VRS-TS2AD151J	AA		C	Resistor(1/10W 150Ω ±5%) [R123]
60	VRS-TS2AD332J	AA		C	Resistor(1/10W 3.3KΩ ±5%) [R125]
61	VRS-TS2AD224J	AA		C	Resistor(1/10W 220KΩ ±5%) [R126]
62	VRS-TS2AD393J	AA		C	Resistor(1/10W 39KΩ ±5%) [R127]
63	VRS-TS2AD822J	AA		C	Resistor(1/10W 8.2KΩ ±5%) [R128]
64	VRS-TS2AD621J	AA		C	Resistor(1/10W 620Ω ±5%) [R129]
65	VRS-TS2AD000J	AA		C	Resistor(1/10W 0Ω ±5%) [R130]
66	VRS-TS2AD332J	AA		C	Resistor(1/10W 3.3KΩ ±5%) [R131]
67	VRS-TS2AD000J	AA		C	Resistor(1/10W 0Ω ±5%) [R132]
68	VRS-TS2AD301J	AA		C	Resistor(1/10W 300Ω ±5%) [R133]
69	VRS-TS2AD203J	AA		C	Resistor(1/10W 20KΩ ±5%) [R134]
70	VRS-TS2AD101J	AA		C	Resistor(1/10W 100Ω ±5%) [R135]
71	VRS-TS2AD203J	AA		C	Resistor(1/10W 20KΩ ±5%) [R140]
72	VRS-TS2AD473J	AA		C	Resistor(1/10W 47KΩ ±5%) [R141]
73	VRS-TS2AD332J	AA		C	Resistor(1/10W 3.3KΩ ±5%) [R142]
74	VRS-TS2AD153J	AA		C	Resistor(1/10W 15KΩ ±5%) [R143]
75	VRS-TS2AD472J	AA		C	Resistor(1/10W 4.7KΩ ±5%) [R144]
76	RTRNI2164XHZZ	AG	N	B	Transformer [T1]
77	VHVERZV5D471/	AC		B	Varistor(ERZVA5D471) [VA1]
78	VHVERZV5D471/	AC		B	Varistor(ERZVA5D471) [VA2]
79	VHEHZ27-1//1	AB		B	Zener diode(HZ27C-1TA) [ZD4]
	(Unit)				
901	DCEKL483BXH01	AX	N	E	TEL/Liu PWB unit [44U]
	DCEKL483BXH08	AX	N	E	TEL/Liu PWB unit [55C]
[9] Power supply PWB unit					
	(Unit)				
901	RDENT2142XHZZ	BA		E	Power supply PWB unit(In October,1999,to the production)
	RDENT2143XHZZ	BA	N	E	Power supply PWB unit(In November,1999,than production)

△
△

Index

PARTS CODE	No.	PRICE RANK	NEW MARK	PART RANK
[C]				
CCNW-212AXH01	1-2	AK	N	C
"	3-1	AK	N	C
CCNW-215AXH01	1-12	AG	N	C
[D]				
DCEKC089MXHZZ	1-45	BN	N	E
"	7-901	BN	N	E
DCEKL483BXH01	1-16	AX	N	E
"	8-901	AX	N	E
DCEKL483BXH08	1-16	AX	N	E
"	8-901	AX	N	E
DCEKP481BXH01	1-1	AP	N	E
"	3-901	AP	N	E
DCEKP481BXH03	1-1	AP	N	E
"	3-901	AP	N	E
DCEKP482BXH01	3-7	AQ	N	E
DUNTK468BXHBG	6-2	AH	N	E
DUNTK468BXHOG	6-2	AH	N	E
[G]				
GCABA2342XHSA	3-3	AH	N	D
GCABA2342XHSA	3-3	AH	N	D
GCABB2343XHSA	1-13	AK	N	D
GCABB2343XHSA	1-13	AK	N	D
GCASP2110XHSA	1-17	AK	N	C
GCASP2110XHSA	1-17	AK	N	C
GCASP2111XHSA	1-18	AH	N	C
GCASP2111XHSA	1-18	AH	N	C
GDAI-2082XHSA	1-46	AD	N	C
GDAI-2082XHSA	1-46	AD	N	C
GDAI-2083XHZZ	1-22	AF	N	C
[H]				
HPNLH2392XHSC	1-54	AE	N	D
HPNLH2392XHSD	1-54	AE	N	D
[J]				
JBTN-2257XHSA	3-4	AD	N	C
JBTN-2257XHSA	3-4	AD	N	C
JBTN-2258XHSA	3-5	AC	N	C
JBTN-2258XHSA	3-5	AC	N	C
JBTN-2261XHSA	3-6	AC	N	C
JBTN-2261XHSA	3-6	AC	N	C
[L]				
LBNDJ2006XHZZ	1-55	AA		C
"	2-19	AA		C
LBSHP2110XHZZ	2-1	AB	N	C
LBSHP2112XHZZ	1-28	AB	N	C
LFRM-2207XHZZ	5-1	AF	N	C
LFRM-2208XHZZ	1-29	AF	N	C
LFRM-2209XHZZ	2-2	AF	N	C
LHLDZ2180XHZZ	2-3	AC	N	C
LHLDZ2181XHZZ	2-4	AC	N	C
LHLDZ2184XHZZ	1-30	AC	N	C
LHLDZ2185XHZZ	1-31	AC	N	C
LPLTG2911XHZZ	4-1	AE		C
LPLTM3049XHZZ	5-2	AD	N	C
LPLTP2908XHZZ	4-2	AE		C
LPLTP3051XHZZ	4-3	AB	N	C
LSTPP2054XHZZ	1-47	AC	N	C
LX-BZ2138XHZZ	1-B1	AB		C
[M]				
MCAMP2027XHZZ	5-4	AC	N	C
MLEV2311XHZZ	5-5	AB	N	C
MLEV2312XHZZ	5-6	AB	N	C
MLEV2314XHZZ	5-8	AB	N	C
MLEV2316XHZZ	1-23	AC	N	C
MLEV2317XHZZ	2-5	AB	N	C
MLEV2319XHZZ	1-49	AC	N	C
MLEV2320XHZZ	1-19	AC	N	C
MLEV2321XHZZ	1-58	AN	N	C
MSPRC2735XHZZ	5-9	AC		C
MSPRC2954XHZZ	1-5	AC		C
MSPRC3110XHZZ	5-10	AB	N	C
MSPRC3112XHZZ	1-33	AC	N	C
MSPRC3117XHZZ	2-6	AB	N	C
MSPRC3148XHZZ	1-34	AC	N	C
MSPRD3116XHZZ	1-24	AB	N	C
MSPRP3119XHZZ	1-14	AC	N	C
MSPRP3123XHZZ	1-15	AC	N	C
MSPRT3139XHZZ	4-5	AA	N	C
MSPRT3140XHZZ	4-4	AA	N	C

PARTS CODE	No.	PRICE RANK	NEW MARK	PART RANK
[N]				
NGERH2278XHZZ	5-12	AC		C
NGERH2379XHZZ	5-13	AC		C
NGERH2391XHZZ	5-15	AC		C
NGERH2475XHZZ	5-17	AB	N	C
NGERH2478XHZZ	1-36	AB	N	C
NGERH2479XHZZ	2-7	AB	N	C
NGERH2480XHZZ	2-8	AB	N	C
NGERH2481XHZZ	2-9	AB	N	C
NGERP2318XHZZ	1-6	AD		C
NROLR2375XHZZ	2-10	AL		C
NROLR2425XHZZ	1-37	AP	N	C
NROLR2428XHZZ	2-11	AP	N	C
NSFTZ2273XHZZ	2-12	AF		C
[P]				
PGIDM2554XHZZ	4-6	AF	N	C
PGIDM2560XHSA	1-7	AC	N	C
PGIDM2560XHSA	1-7	AC	N	C
PGIDM2561XHSA	1-8	AC	N	C
PGIDM2561XHSA	1-8	AC	N	C
PGIDM2562XHZZ	2-13	AD	N	C
PGIDM2563XHSA	1-27	AE	N	C
PGIDM2563XHSA	1-27	AE	N	C
PGIDM2566XHZZ	1-52	AC	N	C
PHOP-2104XHSA	1-9	AF	N	C
PHOP-2104XHSA	1-9	AF	N	C
PHOP-2105XHZZ	6-4	AD	N	C
PSHEZ3410XHZZ	1-57	AB		C
PSHEZ3436XHZZ	2-14	AC		C
PSHEZ3517XHZZ	4-7	AE	N	C
[Q]				
QACCD2027XHZZ	1-20	AR		B
QCNCM2401SC0B	7-92	AA		C
QCNCM2442SC0B	7-85	AB		C
QCNCM2548SC1B	8-30	AH		C
QCNCM7014SC0B	7-87	AD		C
QCNCM7014SC0F	7-89	AB		C
QCNCM7014SC0G	7-84	AB		C
QCNCM7014SC1F	7-90	AD		C
"	7-93	AD		C
QCNCM705BAF06	7-86	AB		C
QCNCW2500SC0F	7-91	AE		C
QCNCW2500SC1B	7-88	AF		C
QCNCW-209AXHZZ	1-39	AH	N	C
QCNCW-210AXHZZ	1-40	AC	N	C
QCNCW-211AXHZZ	2-15	AF	N	C
QCNCW-213AXHZZ	2-16	AC	N	C
QCNCW-3247SCZZ	6-5	AH		C
QCNCW-3975XHGY	6-5	AG		C
QCNCW-3976XHGB	6-3	AK		C
QCNCW-3976XHOG	6-3	AT		C
QCNCW-4753XHZZ	8-2	AE		C
QCNCW-4933XHZZ	5-20	AC		C
QFS-P2010SCZZ	7-100	AD	N	B
QJAKZ2060SC0B	8-31	AD		C
"	8-32	AD		C
QJAKZ2079XH0D	8-29	AD	N	C
QSOCZ2051SC32	7-105	AC		C
QSW-F2224SCZZ	5-21	AE		B
QSW-M2293XHZZ	2-17	AE	N	B
QSW-M2296XHZZ	1-11	AD		B
QSW-Z2263XHZZ	8-35	AG		B
[R]				
RC-FZ3024SCZZ	8-3	AG		C
RCILZ2145XHZZ	7-62	AF		C
"	7-65	AF		C
"	7-110	AF		C
"	7-111	AF		C
"	7-112	AF		C
"	7-113	AF		C
"	7-114	AF		C
"	7-115	AF		C
"	7-116	AF		C
"	7-117	AF		C
"	7-118	AF		C
"	7-119	AF		C
RCORF2123XHZZ	2-20	AD	N	B
RCORF2125XHZZ	1-53	AE		B
RCRSB0297AFZZ	7-206	AD		B
RCRSQ2157SCZZ	7-205	AF	N	B

PARTS CODE	No.	PRICE RANK	NEW MARK	PART RANK
RDENT2142XHZZ	9-901	BA		E
"	1-21	BA		E
RDENT2143XHZZ	1-21	BA	N	E
"	9-901	BA	N	E
RFILN2024XHZZ	8-38	AG		C
"	8-39	AG		C
"	8-40	AG		C
"	8-41	AG		C
"	8-42	AG		C
RHEDZ2059XHZZ	1-41	BF	N	B
RMOTZ2148XHZZ	5-22	AT	N	B
RR-TZ3017SCZZ	7-191	AC		C
"	7-192	AC		C
"	7-195	AC		C
"	7-196	AC		C
"	7-198	AC		C
RR-TZ3018SCZZ	7-190	AC		C
"	7-193	AC		C
"	7-194	AC		C
"	7-197	AC		C
"	7-199	AC		C
"	7-200	AC		C
"	7-201	AC		C
"	7-202	AC		C
RRLYD3138XHZZ	7-204	AG		B
RRLYD3433XHZZ	8-28	AH		B
RTRNI2164XHZZ	8-76	AG	N	B
RUNTZ2054XHZZ	2-18	BE	N	B
[S]				
SPAKA287BXHZZ	6-7	AE	N	D
SPAKA288BXHZZ	6-8	AE	N	D
SPAKA289BXHZZ	6-9	AC	N	D
SPAKA388BXHZZ	6-18	AE	N	D
SPAKA389BXHZZ	6-19	AE	N	D
SPAKC142BXHZZ	6-10	AH	N	D
SPAKC254BXHZZ	6-10	AH	N	D
SPAKP296BXHZZ	6-6	AE	N	D
[T]				
TCADZ2786XHZZ	6-15	AD		D
TCADZ2861XHZZ	6-13	AD	N	D
TCADZ2869XHZZ	6-14	AB		D
TCADZ2913XHZZ	6-13	AD	N	D
TCADZ2935XHZZ	6-16	AA	N	D
TINSE4010XHZA	6-1	AF	N	D
TINSK4065XHZZ	6-1	AG	N	D
TLABH418AXHZZ	6-12	AC		D
TLABM270AXHZZ	6-11	AD	N	D
TLABM458AXHZZ	6-11	AD	N	D
[U]				
UBATL2046SCZZ	7-1	AK		B
[V]				
VCCCTV1HH120J	7-20	AA		C
"	7-21	AA		C
VCCCTV1HH220J	7-34	AA		C
"	7-35	AA		C
"	7-43	AA		C
"	7-44	AA		C
"	7-56	AA		C
"	7-57	AA		C
"	7-59	AA		C
"	7-60	AA		C
"	7-67	AA		C
VCCCTV1HH330J	8-21	AA		C
VCEAGA1EW476M	7-10	AA		C
"	7-11	AA		C
"	7-14	AA		C
VCEAGA1HW106M	7-6	AA		C
"	7-8	AA		C
"	7-12	AA		C
"	8-6	AA		C
VCEAGA1HW107M	7-17	AA		C
VCEAGA1HW226M	7-13	AB		C
"	8-4	AB		C
"	8-5	AB		C
"	8-8	AB		C
"	8-9	AB		C
"	8-10	AB		C
VCEAGA1HW475M	8-7	AA		C
VCKYTV1CF105Z	7-18	AB		C
"	7-22	AB		C

PARTS CODE	No.	PRICE RANK	NEW MARK	PART RANK
VCKYTV1CF105Z	7-25	AB		C
"	7-30	AB		C
"	7-31	AB		C
"	7-33	AB		C
"	7-39	AB		C
"	7-40	AB		C
"	7-41	AB		C
"	7-42	AB		C
"	7-45	AB		C
"	7-50	AB		C
"	7-51	AB		C
"	7-52	AB		C
"	7-54	AB		C
"	7-58	AB		C
"	7-63	AB		C
"	7-64	AB		C
"	7-66	AB		C
"	7-72	AB		C
"	7-77	AB		C
"	7-78	AB		C
"	8-25	AB		C
"	8-26	AB		C
VCKYTV1EB104K	7-48	AA		C
"	7-69	AA		C
"	7-70	AA		C
VCKYTV1EF104Z	7-4	AA		C
"	7-7	AA		C
"	7-29	AA		C
"	7-32	AA		C
"	7-36	AA		C
"	7-38	AA		C
"	7-47	AA		C
"	7-49	AA		C
"	7-55	AA		C
"	7-75	AA		C
"	7-79	AA		C
"	7-81	AA		C
"	8-13	AA		C
"	8-22	AA		C
VCKYTV1HB102K	7-2	AA		C
"	7-3	AA		C
"	7-15	AA		C
"	7-16	AA		C
"	7-23	AA		C
"	7-24	AA		C
"	7-26	AA		C
"	7-46	AA		C
"	7-82	AA		C
"	7-83	AA		C
"	8-14	AA		C
"	8-19	AA		C
VCKYTV1HB103K	7-5	AB		C
"	7-74	AB		C
VCKYTV1HB221K	7-73	AA		C
"	8-16	AA		C
"	8-17	AA		C
VCKYTV1HB222K	7-27	AA		C
"	7-28	AA		C
"	7-37	AA		C
"	7-53	AA		C
"	7-61	AA		C
"	8-11	AA		C
"	8-12	AA		C
VCKYTV1HB392K	8-15	AA		C
VCKYTV1HB393K	8-27	AB		C
VCKYTV1HB472K	7-76	AA		C
VCKYTV1HB821K	8-24	AA		C
VCKYTV1HF104Z	7-19	AA		C
"	7-80	AA		C
"	8-18	AA		C
"	8-20	AA		C
"	8-23	AA		C
VHDDSS133/-1	8-33	AA		B
"	8-34	AA		B
VHDHRW0202B-1	7-98	AD		B
VHD1SS355/-1	7-95	AB		B
"	7-96	AB		B
"	7-97	AB		B
"	7-99	AB		B
VHEHZ27-1/-1	8-79	AB		B

PARTS CODE	No.	PRICE RANK	NEW MARK	PART RANK
VHIFC2FM209-1	7-102	BD	N	B
"	7-104	BD	N	B
VHINJM2113M-1	7-107	AG		B
VHINJM2904M-2	8-36	AG		B
"	8-37	AG		B
VHITC7WT74FU1	7-101	AF	N	B
VHIULN2003AN/	7-108	AE		B
VHIW24258S7LE	7-103	AQ		B
VHIXC61AN45M1	7-109	AE	N	B
VHI27010FZF0C	7-105	BM	N	B
VHI62FP332P-1	7-203	AF		B
VHPSG206S/-1	7-120	AG		B
VHPTLP521-1BL	8-43	AE		B
VHVERZV5D471/	8-77	AC		B
"	8-78	AC		B
VHVRA391PV6-1	8-1	AE		B
VRD-HT2HY223J	8-47	AA		C
VRS-HT3AA101J	7-94	AA		C
VRS-TS2AD000J	7-9	AA		C
"	7-68	AA		C
"	7-71	AA		C
"	7-129	AA		C
"	7-131	AA		C
"	7-144	AA		C
"	7-157	AA		C
"	7-163	AA		C
"	7-164	AA		C
"	7-172	AA		C
"	7-173	AA		C
"	7-176	AA		C
"	8-53	AA		C
"	8-65	AA		C
"	8-67	AA		C
VRS-TS2AD101J	8-70	AA		C
VRS-TS2AD102J	7-156	AA		C
"	7-171	AA		C
"	7-180	AA		C
"	8-50	AA		C
"	8-58	AA		C
VRS-TS2AD103J	7-126	AA		C
"	7-150	AA		C
"	7-159	AA		C
"	7-170	AA		C
"	7-175	AA		C
"	7-188	AA		C
VRS-TS2AD104J	7-174	AA		C
"	7-178	AA		C
"	7-179	AA		C
"	7-186	AA		C
VRS-TS2AD105J	7-158	AA		C
VRS-TS2AD106J	7-127	AA		C
VRS-TS2AD121J	7-160	AA		C
VRS-TS2AD151J	7-139	AA		C
"	8-59	AA		C
VRS-TS2AD152J	8-49	AA		C
VRS-TS2AD153J	7-166	AA		C
"	8-74	AA		C
VRS-TS2AD201J	7-130	AG		C
"	7-142	AG		C
VRS-TS2AD203J	7-167	AA		C
"	7-181	AA		C
"	7-185	AA		C
"	8-52	AA		C
"	8-54	AA		C
"	8-69	AA		C
"	8-71	AA		C
VRS-TS2AD222J	7-161	AA		C
VRS-TS2AD223J	7-138	AA		C
"	7-149	AA		C
"	8-48	AA		C
VRS-TS2AD224J	7-165	AA		C
"	8-61	AA		C
VRS-TS2AD271J	7-124	AA		C
"	7-134	AA		C
"	7-187	AA		C
VRS-TS2AD3R0J	7-128	AA		C
VRS-TS2AD301J	8-68	AA		C
VRS-TS2AD303J	7-168	AA		C
VRS-TS2AD332J	8-57	AA		C
"	8-60	AA		C

PARTS CODE	No.	PRICE RANK	NEW MARK	PART RANK
VRS-TS2AD332J	8-66	AA		C
"	8-73	AA		C
VRS-TS2AD333J	7-125	AA		C
"	7-135	AA		C
"	7-136	AA		C
"	7-137	AA		C
"	7-141	AA		C
"	7-143	AA		C
"	7-147	AA		C
"	7-148	AA		C
"	7-151	AA		C
"	7-152	AA		C
"	7-153	AA		C
"	7-154	AA		C
"	7-162	AA		C
VRS-TS2AD393J	8-62	AA		C
VRS-TS2AD433J	7-169	AA		C
"	8-55	AA		C
VRS-TS2AD471J	7-132	AA		C
"	7-133	AA		C
"	7-140	AA		C
"	7-145	AA		C
"	7-146	AA		C
VRS-TS2AD472J	8-75	AA		C
VRS-TS2AD473J	7-177	AA		C
"	8-72	AA		C
VRS-TS2AD474J	7-184	AA		C
VRS-TS2AD512J	7-155	AA		C
"	7-182	AA		C
"	8-51	AA		C
VRS-TS2AD562J	7-183	AA		C
VRS-TS2AD621J	8-64	AA		C
VRS-TS2AD680J	7-189	AA		C
VRS-TS2AD822J	8-63	AA		C
VRSTS2AD8662F	8-56	AA		C
VSRNC1402/-1	7-122	AC		B
"	8-45	AC		B
"	8-46	AC		B
VS2SA1037KS-1	7-121	AB		B
"	7-123	AB		B
VS2SC2412KR-1	8-44	AD		B
[X]				
XBBS030P06000	1-B4	AA		C
XBPSN40P06K00	1-B5	AA		C
XEBS030P08000	1-B3	AA		C
"	5-B3	AA		C
XEBS030P12000	1-B7	AA		C
XUBSD20P06000	3-B2	AA		C

SHARP

COPYRIGHT © 1999 BY SHARP CORPORATION

ALL RIGHTS RESERVED.

No part of this publication may be reproduced, stored in a retrieval system, or transmitted in any form or by any means, electronic, mechanical, photocopying, recording, or otherwise, without prior written permission of the publisher.

SHARP CORPORATION
Communication Systems Group
Quality & Reliability Control Center
Higashihiroshima, Hiroshima 739-0192, Japan
Printed in U.S.A.

9911-2084NS•IS•T