



GILSON COMPANY, INC.

Laboratory Equipment for PARTICLE SIZE ANALYSIS • CONSTRUCTION MATERIALS TESTING • SAMPLING
SOIL & ENVIRONMENTAL TESTING



Gilson Porta-Screen

Models PS-3 & PS-4

Operating and Service Manual

Copyright 1999

SAFETY INSTRUCTIONS

GILSON PORTA-SCREEN

WHETHER YOU ARE THE OWNER, EMPLOYER, OPERATOR, OR MAINTENANCE PERSON FOR THIS MACHINE, SAFETY IS YOUR RESPONSIBILITY. YOU ARE RESPONSIBLE FOR OPERATING AND MAINTAINING THIS EQUIPMENT IN COMPLIANCE WITH THESE INSTRUCTIONS AND FOR USING COMMON SENSE. YOU SHOULD ALWAYS REVIEW AND COMPLETELY UNDERSTAND THESE SAFETY AND OPERATING INSTRUCTIONS BEFORE USING THIS MACHINE.



DANGER: This machine operates on electrical current. Improper use could result in electric shock, electrocution, injury by explosion, or even death.

- I. **Always** make sure the motor and electrical components are appropriate and properly configured for your intended use and available power source. Porta-Screens are normally wired for 115 volts 60Hz and come with a 1/4 hp non-explosion-proof motor.
- II. **Always** check electrical wiring for loose connections and for pinched or frayed wiring.
- III. **Always** ground the Porta-Screen. Connect its three-pronged plug to a properly-wired, three-pronged, grounded receptacle with appropriate electrical current for the machine.
- IV. **Always** disconnect and lock out the power supply before performing maintenance or repairs on your machine.



DANGER: The 1/4 hp, 115-volt motor of the Porta-Screen has internal thermal protection. Therefore, the motor will automatically shut off if overloaded. The motor will restart by itself after cooling unless disconnected from its power source during cool-down.



DANGER: Do not use the Porta-Screen in an explosive or hazardous atmosphere. It is not explosion-proof.

Warning: Operate only in a properly-ventilated area.

Warning: Level the Porta-Screen before operation.

Warning: Stop the Porta-Screen if excessive vibration or machine movement occurs.

Warning: Always take care not to pinch your fingers between the clamp levers and the machine frame.

Warning: Do not operate without all guards and covers in place.

Warning: Keep all parts of your body away from moving parts of the machine while it is operating.

Warning: Do not wear loose clothing which might be caught in moving parts of the machine.

Warning: Wear safety glasses, protective clothing, and hearing protection. Wear approved NIOSH/MSHA respirator as required by the sample to prevent your inhaling any dust which may be considered hazardous.

Table of Contents

| | Safety Instructions | Inside Cover |
|-------------|-------------------------------------|---------------------|
| I. | Unpacking & Installation | 2 |
| II. | Operation | 3 |
| III. | Sample Capacity | 4 |
| IV. | Maintenance and Disassembly | 5-7 |
| V. | Parts | 8-11 |
| VI. | Faxback Form | 12 |

Models PS-3 and PS-4

The Gilson Porta-Screen is a portable shaker for field control of construction aggregates and for quality control in asphalt and ready-mix plants. It is designed for best separation in the 2" (50.8mm) to No. 16 (1.18mm) range. Model PS-3 holds five screen trays and a pan; PS-4's capacity is seven trays and a pan.

I. Unpacking & Installation

The Porta-Screen, packed for shipment, weighs between 225 and 255 lbs, depending on the model and the number of trays packed inside. Use equipment to adequately handle this weight safely.

1. The Porta-Screen is shipped in a cardboard carton. Before you accept the shipment, check the carton for visible damage. Note any damage on the freight bill, and proceed with inspection.
2. Place the carton on its side so that you can remove the staples from the bottom. Open the bottom flaps and set the machine upright again. Lift off the carton and set it aside until you are sure that the Porta-Screen is in acceptable condition.
3. Check the machine for shipping damage. If you find concealed damage after you have signed for the Porta-Screen, call the delivering carrier immediately for an inspection. Save all packing materials, and leave the Porta-Screen as it is.
4. Check the tag on the electric motor of the Porta-Screen to be sure that the machine is wired as ordered.
5. Release clamping pressure on the Porta-Screen trays by rotating the clamp levers outward and upward 180°.
6. Remove trays by sliding them out the front of the machine.
7. Choose your operating site:
 - A. The Porta-Screen requires a properly-wired, three-pronged, grounded receptacle with appropriate electrical current for the machine.
 - B. Choose a well-ventilated site.
 - C. Set the Porta-Screen on a solid, stable floor, platform, or other surface.
8. When you have placed the Porta-Screen in its operating location, and each time you move it, level the unit by adjusting the three leveling legs.

To extend a leg, place your foot on the edge of the pad, and lift up on the machine above the leg.

To contract a leg, depress the leg lock tab, which extends from the case above each footpad.

Use the bullseye level in the top frame crossbar as a guide.

After you have placed the Porta-Screen into service, observe the distribution of sample material in the trays at the end of a test. If the material is not evenly distributed, re-level the machine.
9. Reinstall the trays in the Porta-Screen. Leave them unclamped.
10. Do not plug in the Porta-Screen until you are ready to use it.

II. Operation

WHETHER YOU ARE THE OWNER, EMPLOYER, OPERATOR, OR MAINTENANCE PERSON FOR THIS MACHINE, SAFETY IS YOUR RESPONSIBILITY. YOU ARE RESPONSIBLE FOR OPERATING AND MAINTAINING THIS EQUIPMENT IN COMPLIANCE WITH THESE INSTRUCTIONS AND FOR USING COMMON SENSE. YOU SHOULD ALWAYS REVIEW AND COMPLETELY UNDERSTAND THESE SAFETY AND OPERATING INSTRUCTIONS BEFORE USING THIS MACHINE.

Warning: Operate only in a properly ventilated area.

Warning: Level the Porta-Screen before operation.

Warning: Stop the Porta-Screen if excessive vibration or machine movement occurs.

Warning: Always take care not to pinch your fingers between the clamp levers and the machine frame.

Warning: Do not operate without all guards and covers in place.

Warning: Keep all parts of your body away from moving parts of the machine while it is operating.

Warning: Do not wear loose clothing which might be caught in moving parts of the machine.

Warning: Wear safety glasses, protective clothing, and hearing protection. Wear approved NIOSH/MSHA respirator as required by the sample to prevent your inhaling any dust which may be considered hazardous.

Procedure:

Read and be sure you understand all safety, operating, and timer instructions, as well as specifications and procedures for your test.

1. Check to see that the Porta-Screen is level.
2. Select and load the appropriate trays.

Fill all the slots: five trays and pan for the PS-3
seven trays and pan for the PS-4

The Porta-Screen will not clamp or operate properly unless fully loaded with trays. If your test requires fewer trays than the capacity of the Porta-Screen, you may insert the required trays in the upper slots with the pan immediately below. Then fill the lower slots with extra trays.
3. Clamp the trays by rotating the clamp levers so that they point down.
4. Pour your sample into the top tray. Refer to the sample capacity information and be sure not to overload the Porta-Screen.
5. Connect the three-pronged plug into a properly-wired, grounded receptacle with appropriate electrical current.
6. Set and activate the timer.
7. When the machine stops, unclamp the trays by rotating the clamp levers so they point up. Remove and empty the trays, following the directions in your test specifications.
8. When you have finished your test, unplug the machine. Do not reconnect power until you are ready to use the machine again.
9. Store clean, empty trays in the unit, leaving them unclamped.
10. Re-level the machine before the next use.

III. Sample Capacity

Capacity of the Porta-Screen depends on the specifications of the test and the type and size of the material being tested. For any given sample, the Porta-Screen's maximum capacity is determined by the tray which has the largest load at the end of the test. This is the limiting tray.

Coarse Aggregates:

Minimum quantity of sample is usually established by the specifications of the test procedure. For example, ASTM C-136 "Specification for the Sieve or Screen Analysis of Fine and Coarse Aggregates" calls for the minimum weight of the test sample of coarse aggregates (density such as limestone or gravel) as follows:

| Nominal Maximum Size of Particle mm (in.) | Minimum Sample Weight Kg. (lb.) |
|--|------------------------------------|
| 9.5 (3/8) | 1 (2) |
| 12.5 (1/2) | 2 (4) |
| 19.0 (3/4) | 5 (11) |
| 25.0 (1) | 10 (22) |
| 37.5 (1-1/2) | 15 (33) |
| 50 (2) | 20 (44) |
| 63 (2-1/2) | 35 (77) |

These guidelines on minimum sample size quantities are for representative samples. Always take a much larger amount, perhaps from several spots in a storage bin or stockpile. Then combine and reduce them to the correct quantity by splitting.

With coarse series trays, (2" to No. 4), the limiting tray should have no more than one layer of particles over the wire cloth at the end of the test. Therefore, lightweight aggregates or coal must be tested in lower sample weights. High-density ores or pellets may be tested in larger amounts by weight. Many light materials are also soft, and test times should be limited to avoid degradation of the sample.

Most samples of up to 2" topsize can be handled in a single batch without difficulty. We do not recommend the use of trays with mesh sizes above 1-1/2", since larger particles become wedged in the mesh and make it difficult to remove the trays.

Fine Aggregates:

With fine series trays, (No. 8 to No. 200), the limiting tray should contain no more than approximately four grams per square inch of sieve surface at the end of a test. Assuming that the material is about the density of sand, there will be approximately 800 grams maximum on the limiting tray.

Since the Porta-Screen is designed primarily for use in the 2" to No. 20 range, separations in finer sizes will not be as precise. If you are testing materials exclusively in the fine range, we recommend equipment specifically designed for this purpose, such as the Gilson Model SS-8R Sieve Shaker.

IV. Maintenance

READ AND BE SURE YOU UNDERSTAND ALL SAFETY AND MAINTENANCE INSTRUCTIONS BEFORE PERFORMING MAINTENANCE ON YOUR PORTA-SCREEN.

ALWAYS DISCONNECT AND LOCK OUT ELECTRIC POWER BEFORE PERFORMING MAINTENANCE.

Clamping System:

1. DISCONNECT AND LOCK OUT ELECTRIC POWER.
 2. Load the Porta-Screen with trays and pan, filling all the slots.
 3. Rotate the clamp levers (#38) so that they point down.
 4. Locate the clamp adjusting nuts (#9), which are on the lower ends of the four clamp tension rods (#7).
 5. Tighten the nuts only enough to prevent the trays from rattling when the machine is operating.
- b. per case cover removed, remove lower front and rear case covers.
 - b. Apply a small amount of any good-quality bearing grease.
 - c. Reassemble in reverse order.

Lubrication:

1. DISCONNECT AND LOCK OUT ELECTRIC POWER.
 2. Remove and set aside trays and pan.
 3. Remove upper case cover.
 4. Connection Rod Bearing:
 - Lubricate the connecting rod bearing (#52) after every 80 to 100 hours of operation.
 - a. Rotate drive shaft (#20) slightly by hand until the grease fitting at the lower end of the connecting rod (#50) is accessible. (Grease fitting may be pointing either to the front or to the back of the Porta-Screen).
 - b. Apply a small amount of any good-quality bearing grease.
 - c. Proceed to shaft bearing lubrication.
 5. Shaft Bearings:
 - There are two bearings (#47), front and rear, on the drive shaft (#20), and two bearings (#41), front and rear, on each of the two counterweight shafts (#12, 13). Some Porta-Screens have sealed shaft bearings; others have shaft bearings with grease fittings. If the shaft bearings on your machine have grease fittings, lubricate the bearings after every 80 to 100 hours of operation.
 - a. WITH ELECTRIC POWER DISCONNECTED AND LOCKED OUT, and trays, pan, and up-
6. Motor Bearings: Lubricate annually.
 - a. Remove trays, pan, and upper case cover.
 - b. Remove lower front and rear case covers.
 - c. Find and remove the oil plugs at each end of the motor.
 - d. Insert a few drops of oil.
 - e. Replace plugs.
 - f. Reassemble in reverse order.
 7. Idler Pulley Bearings:
 - These sealed bearings (#62) do not require lubrication.

Belts: The Drive Belt (#22) should fit snugly. If the belt is too tight, it will soon wear out, causing bearings to wear and resulting in noisy operation. A loose belt may cause the unit to run too slowly or to slip. Keep the drive pulley (#21) and motor pulley (#60) aligned so that the drive belt is straight.

The Timing Belt (#16) should fit tightly.

Access to Belts:

1. DISCONNECT AND LOCK OUT ELECTRIC POWER.
2. Remove and set aside trays and pan.
3. Remove all case covers.
4. Drive Belt:
 - Check tension by pressing on the span of the belt. If properly adjusted, the belt should be deflected 1/64th of the value of the distance between the pulleys. To adjust or remove, loosen the motor mounting bolts (#61); and the motor will slide up, loosening the belt tension.

- a. To adjust, move the motor up or down until the belt tension is correct. Retighten the nuts.
 - b. Or remove the loosened belt if it is worn, and install a new one. Obtain the correct tension by moving the motor up or down. Retighten the nuts.
 - c. Continue or reassemble.
5. Timing Belt:
- Check tension by pressing on the span of the belt. The belt should be tight. To adjust or remove the timing belt, loosen the two idler bracket mounting screws (#45). Loosen the nut on the adjusting screw (#46).
- a. To tighten: Turn in the adjusting screw to pull the bracket (#17) down and increase tension on the belt. Retighten the nut to hold the bracket in position. Reassemble.
 - b. To replace: Loosen the adjusting screw to permit the idler bracket to move upward, loosening the tension on the timing belt so that you can remove it. Before reinstalling belt,
 - (1) Rotate drive shaft (#20) until the connecting rod (#50) is at its highest position.
 - (2) Rotate counterweight shafts (#12,13) until counterweights are at their lowest position.
 - (3) Fit the belt around the left counterweight shaft pulley, around the timing pulley (#49), above the right counterweight shaft pulley, and around the idler pulley (#19).
 - (4) Tighten the idler bracket adjusting screw until the timing belt is tight, making certain that you do not change the position of the shafts. Lock the idler bracket in position with the nut. Tighten the bracket mounting screws.
 - (5) Reassemble.

DO NOT PLUG IN THE PORTA-SCREEN UNTIL YOU ARE READY TO USE IT.

Bearing Replacement:

1. Guide Bearing Assemblies:

The Porta-Screen has three guide bearing assemblies: each has a housing and guide bushing. The two upper guide bearings (#34) are mounted to the top frame crossbar. The lower guide bearing (#59) is mounted to the under-

side of the vibrating unit.

If you notice side-to-side movement of the vibrating unit during operation, inspect the guide bearings and replace them if necessary. We recommend replacement of all three assemblies at the same time.

- a. DISCONNECT AND LOCK OUT ELECTRIC POWER.
- b. Remove and set aside trays and pan.
- c. Remove top frame screws (#2), and lift off top frame crossbar (#1).
- d. Upper:
 - (1) Remove mounting screws (#35) to detach bearing housing (#34).
 - (2) Replace with new bearing housing assembly.
- e. Lower:
 - (1) Remove all case covers.
 - (2) Remove the connecting rod mounting bolt (#24).
 - (3) Lift the entire vibrating unit assembly up and out of the Porta-Screen frame.
 - (4) Remove mounting screws (#56) to detach bearing housing unit (#59).
 - (5) Replace with new bearing housing assembly.
- f. Reassemble in reverse order.

DO NOT PLUG IN THE PORTA-SCREEN UNTIL YOU ARE READY TO USE IT.

2. Connecting Rod & Drive Shaft Bearings:

The connecting rod (#50) can be replaced as an assembly, or you can press out and replace its bearing and bushing (#52).

The drive shaft (#20) has front and rear bearings (#47). We recommend replacement of both front and rear bearings as a set.

- a. DISCONNECT AND LOCK OUT ELECTRIC POWER.
- b. Remove and set aside trays and pan.
- c. Remove top frame screws (#2).
- d. Lift off top frame crossbar (#1).
- e. Remove all case covers.
- f. Remove the connecting rod mounting bolt (#24).
- g. Lift the entire vibrating unit assembly up and out of the Porta-Screen frame.

- h. Loosen the motor mounting bolts to release tension on the drive belt, and remove the drive belt from its pulleys.
- i. Loosen the setscrew in the drive pulley (#21), and slide the pulley off the drive shaft.
- j. Loosen the setscrew in the rear drive shaft bearing.
- k. Loosen the idler bracket mounting and adjusting screws (#45, 46) to release tension on the timing belt.
- l. Remove the timing belt (#16).
- m. Loosen the setscrew in the drive shaft pulley (#49), and slide the pulley off the drive shaft.
- n. Remove the mounting screws from the front drive shaft bearing (#47).
- o. Hold onto the top of the connecting rod (#50) while you pull the drive shaft out from the front of the machine with the front bearing attached.
- p. Remove the connecting rod (#50).
- q. Install new connecting rod assembly or press new bushing and bearing into existing connecting rod.
- r. Replace drive shaft bearings if needed.
- s. Continue or reassemble in reverse order. When replacing timing belt, refer to timing belt instructions and be sure that counterweights are aligned properly.

DO NOT PLUG IN THE PORTA-SCREEN UNTIL YOU ARE READY TO USE IT.

3. Counterweight Shaft Bearings:

Each of the two counterweight shafts (#12, 13) has a front and a rear bearing (#41). We recommend replacement of both bearings on a shaft. If you have disassembled the Porta-Screen to replace the connecting rod and/or drive shaft bearings, skip to step h. Otherwise, disassemble as follows:

- a. DISCONNECT AND LOCK OUT ELECTRIC POWER.
- b. Remove and set aside tray and pan.
- c. Remove top frame screws (#2).
- d. Lift off top frame crossbar (#1).
- e. Remove all case covers.
- f. Remove the connecting rod mounting bolt (#24).
- g. Lift the entire vibrating unit assembly up and out of the Porta-Screen frame.

- h. Loosen the idler bracket mounting and adjusting (#45, 46) to release tension on the timing belt.
- i. Remove the timing belt (#16).
- j. Loosen the bolts on the rear counterweight clamp bracket (#43), and remove the counterweight from the shaft.
- k. Loosen the setscrew which holds the rear bearing to the counterweight shaft.
- l. Remove the mounting screws (#42) which hold the front counterweight shaft bearing (#41) to the main frame.
- m. Pull the counterweight shaft from the front of the machine with its front counterweight, pulley, and front bearing all attached.
- n. Reinstall parts as needed.
- o. Reassemble in reverse order. When replacing timing belt, refer to timing belt instructions and be sure that the counterweights are aligned properly.

DO NOT PLUG IN THE PORTA-SCREEN UNTIL YOU ARE READY TO USE IT.

4. Wire Cloth:

Check condition of wire cloth both before and after operation. Test results can be only as accurate as the size of wire cloth openings. Always replace with testing grade wire cloth only.

Testing grade wire cloth is a precision-made material and should be treated with care. The ASTM E-11 specification permits only very slight variations in average opening and wire diameter. Abrasion due to normal use and/or improper cleaning and handling can cause the wire cloth to be out of specification to a considerable degree before it appears worn. Check it frequently to be sure that it conforms to your test specifications.

The life of the wire cloth can be prolonged by establishing proper procedures for handling, cleaning, and storage of trays. The Porta-Pan Accessory is helpful in the repetitive sequence of emptying trays, cleaning wire cloth, and weighing sample fractions.

Wire cloth may eventually sag, reducing its effective screening area. Wire sizes 2" to No. 14 are rigid and self-supporting. Trays for No. 16 through No. 80 wire cloth contain three wire cloth support strips. No. 100 and finer trays have supporting backup cloth to minimize wear and distortion. When you replace No. 16 and finer wire cloth, always use support strips or backup cloth as indicated.

Parts List for PS-3 and PS-4 Porta-Screens

| Parts | No. Req'd |
|---|-----------|
| Outer Case & Frame Parts | |
| 1 Top frame cross bar | 1 |
| 2 Top frame screw & lock washer | 4 |
| 31 Bullseye level with cushion washer | 1 |
| 36 Bullseye level adjusting screws | 3 |
| 27 Leg lock tab | 3 |
| 33 Leg lock tab spring | 3 |
| 65,28 Leveling leg (65), with adjusting screw pad, nut & washer | 3 |
| 29 Main frame | 1 |
| 30 Vibrating unit assembly | |
| Upper case cover | 2 |
| 11A Lower case cover, front | 1 |
| Lower case cover, rear | 1 |
| Upper Guide Bearing Assembly Parts | |
| 34 Upper guide bearing housing with guide bushing | 2 |
| 35 Upper guide bearing mounting screw & lock washer | 4 |
| 4 Upper guide bearing pin & set screw | 2 |
| Clamping Assembly Parts, Right & Left | |
| 5A Clamp lever with mounting bracket 6F left side | 1 |
| 5B Clamp lever with mounting bracket 6F right side | 1 |
| 38 Clamp lever handle grip | 2 |
| 6R Rear clamp lever mounting bracket | 2 |
| 39 Clamp lever mounting bracket screw & lock washer | 8 |
| 7 Clamp tension rod | 4 |
| 40 Clamp tension rod retainer clip, screw and lock washer | 4 |
| 8 Clamp bar | 1 |
| 9 Clamp adjusting nut and spacer | 4 |
| Counterweight Assembly Parts | |
| 12 Left counterweight shaft (short) | 1 |
| 13 Right counterweight shaft (long) | 1 |
| 41 Counterweight shaft bearing | 4 |
| 42 Counterweight shaft bearing mounting screw & lock washer | 8 |
| 14 Counterweight | 4 |
| 43 Counterweight clamp bracket | 4 |
| 44 Counterweight clamp bracket bolt & lock washer | 8 |
| 15 Counterweight shaft pulley & set screw | 2 |
| 16 Timing belt | 1 |
| 17 Idler bracket | 1 |
| 45 Idler bracket mounting screw with lock & flat washers | 2 |
| 46 Idler bracket adjusting screw with locking nut | 1 |
| 18 Idler pulley mounting screw & lock washer | 1 |
| 19/62 Idler pulley with bearing set | 1 |
| Drive Shaft Assembly Parts | |
| 20 Drive shaft with eccentric, set screw, and roll pin | 1 |
| 47 Drive shaft bearing | 2 |
| 42 Drive shaft bearing mounting screw & lock washer | 4 |
| 49 Timing pulley & set screw | 1 |
| 21 Drive pulley with set screw | 1 |
| 22 Drive belt | 1 |

Parts List for PS-3 and PS-4 Porta-Screens

| Parts | No. Req'd |
|---|-----------|
| Connecting Rod Assembly Parts | |
| 50 Connecting rod with grease fitting | 1 |
| 51 Connecting rod rubber bushing | 1 |
| 52 Connecting rod bearing with inner race | 1 |
| — (Connecting rod assembly - Parts 50, 51, 52, assembled) | (1) |
| 24 Connecting rod mounting bolt with lock nut | 1 |
| 54 Connecting rod mounting bolt spacer | 2 |
| Lower Guide Bearing Assembly Parts | |
| 59 Lower guide bearing housing with guide bushing | 1 |
| 56 Lower guide bearing mounting screw & lock washer | 2 |
| 26 Lower guide bearing pin | 1 |
| 64 Lower guide bearing pin clamp bolt with lock nut | 1 |
| Electric & Drive Parts | |
| 63 Motor, 1/4 hp, 115V, 60Hz, 1Ph, 1725 RPM | 1 |
| 60 Motor Pulley & set screw | 1 |
| 61 Motor mounting bolt with lock & flat washer | 4 |
| — Electric cord assembly, motor-to-timer | 1 |
| — Electric cord assembly, with ground plug | 1 |
| — Electric cord grip grommet | 1 |
| Timer, Digital (EDA) | 1 |
| Timer, Digital (Artisan) | 1 |

Replacement Trays and Wire Cloth

| | | |
|--|--------------|---|
| Porta-Screen Tray, complete with wire cloth | <u>Model</u> | |
| | PSA-300 | 2" to No. 4 inclusive |
| | PSA-301 | No. 5 to No. 14 inclusive |
| | PSA-302 | No. 16 to No. 80 inclusive w/ wire cloth supports |
| | PSA-302 | No. 100, with backup cloth |
| | PSA-306 | No. 200, with backup cloth |
| | PSA-310 | Dustpan tray |
| Replacement Wire Cloth, complete with metal shields & resilient gasket backing | <u>Model</u> | |
| | PSA-325 | 2" to No. 4 inclusive |
| | PSA-326A | No. 5 to No. 14 inclusive |
| | PSA-326B | No. 16 to No. 100 inclusive |
| | PSA-327 | No. 200 |
| | PSA-225 | Backup cloth (use with No. 100 to No. 200) |
| Screen Tray Parts | <u>Model</u> | |
| | PSA-336 | Tray, complete, but without wire cloth, supports, or backup cloth Tray side clamp (4 req'd per tray) Tray bolts & nuts (12 req'd per tray) Wire cloth support (3 req'd per tray) |

PS-3 & PS-4
PARTS DIAGRAM

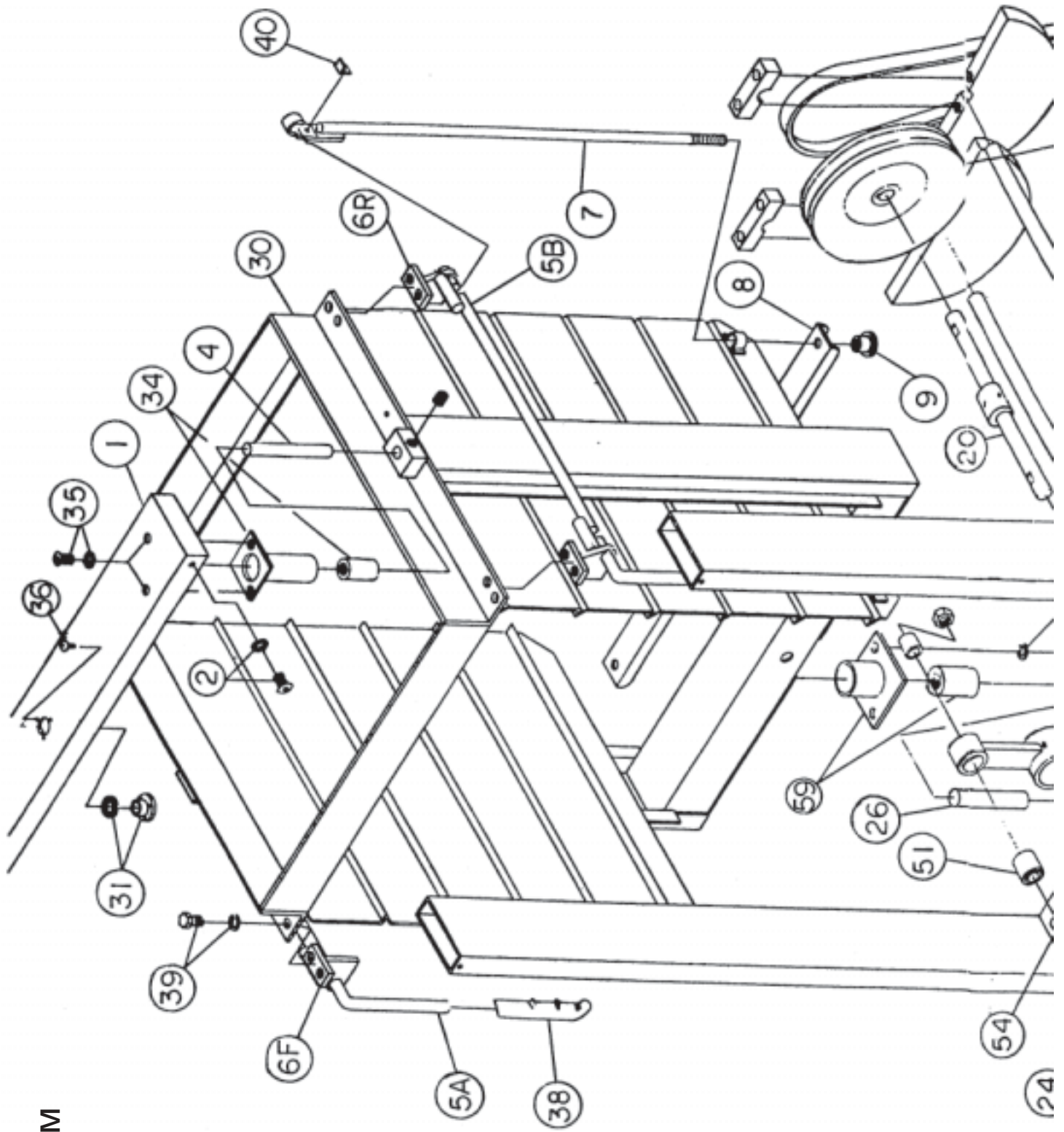

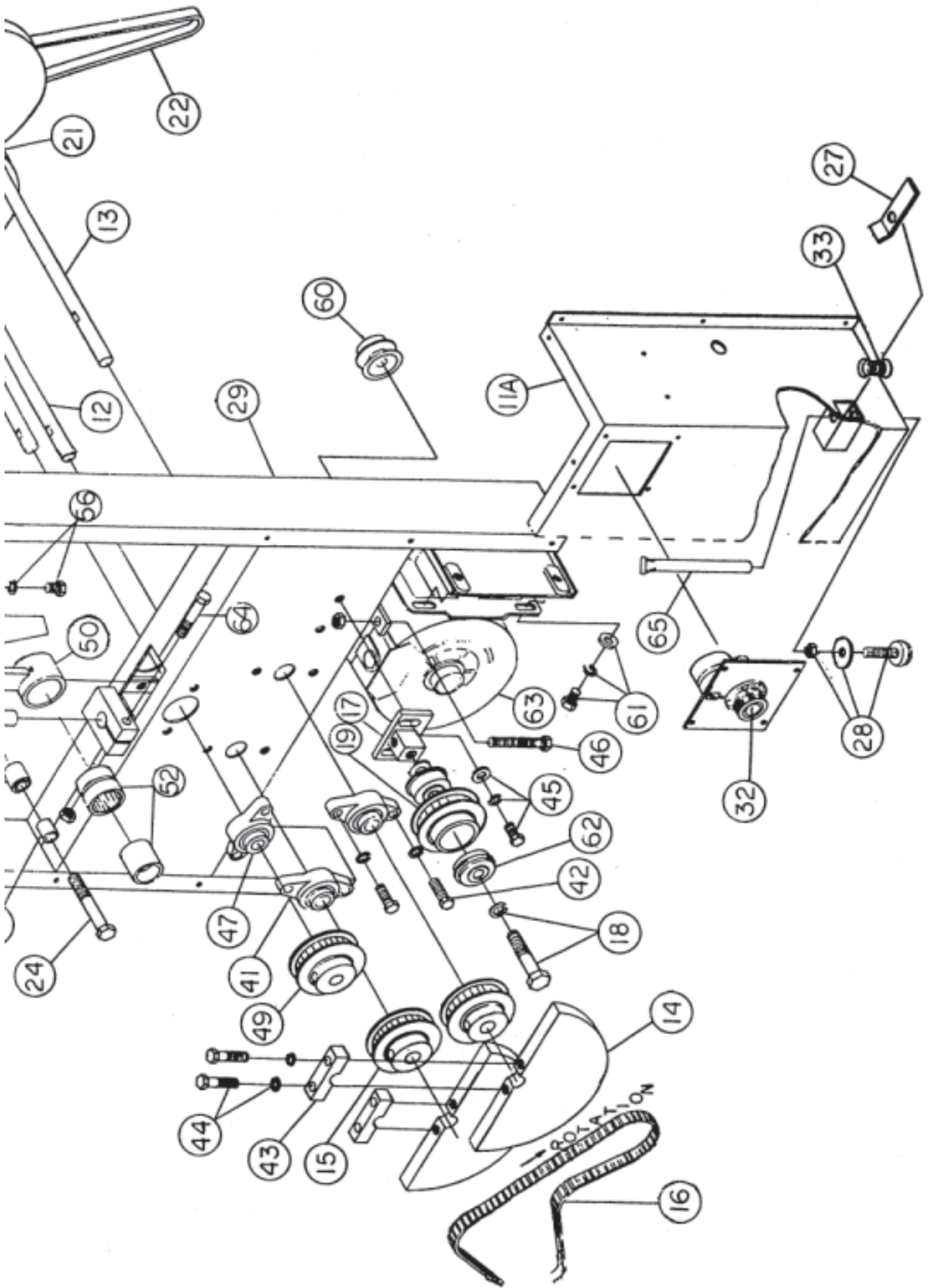



Porta-Screen has Foot-Tab leveling.

Porta-Screen Tray cloth has metal shields to eliminate partial openings.

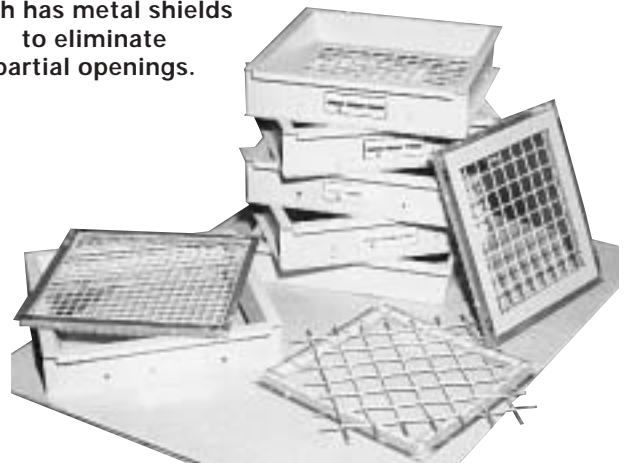

PSA-114

PORTA WHEELS

PS-3 Porta-Screen has predrilled mounting holes for quick addition of PSA-114 Porta Wheels for mobility. Set includes two ball bearing rubber tires attached to steel mounting fixtures.