

Product Survey

REMARKS:

Each year 4 Product Surveys are published. From Product Survey 2002-1 onwards the contents of the second, the third and the fourth issue is an updating of the previous one; so e.g. Product Survey 2002-2 replaces 2002-1, Product Survey 2002-3 replaces Product Survey's 2002-1 and 2002-2 and the yearbook Product Survey 2002-4 replaces the Product Survey's 2002-1, 2002-2 and 2002-3.

CONTENTS**PAGE**

Publication survey	PS02-1 2
Remote control survey	PS02-1 5
Tuner survey	PS02-1 5
CRT survey	PS02-1 5
Software survey	PS02-1 7
Model number survey	PS02-1 20
Stylings with parts list	PS02-1 24

Copyright 2002 Philips Consumer Electronics Eindhoven, The Netherlands. All rights reserved. No part of this publication may be reproduced, stored in a retrieval system or transmitted, in any form or by any means, electronic, mechanical, photocopying, or otherwise without the prior permission of Philips.

Safety regulations require that the set be restored to its original condition and that parts which are identical with those specified be used.

Les normes de sécurité exigent que l'appareil soit remis à l'état d'origine et que soient utilisées les pièces de rechange identiques à celles spécifiées.

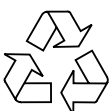

Publication survey

SERVICE MANUAL	LANGUAGE	CODE NUMBER
SM A10A	GB	3122 785 10581
SM A10A AA Supplement (DVD)	GB	3122 785 10990

SERVICE INFORMATION	LANGUAGE	CODE NUMBER
SI A10A AA 00.01	GB	3122 785 40250

SERVICE MANUAL	LANGUAGE	CODE NUMBER
SM A10E AA	GB	3122 785 10430
SM A10E AA	NL	3122 785 10440
SM A10E AA	D	3122 785 10450
SM A10E AA	F	3122 785 10460
SM A10E AA	I	3122 785 10470
SM A10E AA	E	3122 785 10480
SM A10E AA Supplement	GB	3122 785 10980

SERVICE MANUAL	LANGUAGE	CODE NUMBER
SM A10E AA Supplement (DVD)	GB	3122 785 11030
SM A10E AA Supplement (DVD)	D	3122 785 11040
SM A10E AA Supplement (DVD)	F	3122 785 11050
SM A10E AA Supplement (DVD)	I	3122 785 11060
SM A10E AA Supplement (DVD)	E	3122 785 11070

SERVICE MANUAL	LANGUAGE	CODE NUMBER
SM A10E DPL Supplement	GB	3122 785 10980

SERVICE INFORMATION	LANGUAGE	CODE NUMBER
SI A10E AA 01.01	GB	3122 785 40260
SI A10E AA 01.01	D	3122 785 40340
SI A10E AA 01.01	F	3122 785 40350
SI A10E AA 01.01	I	3122 785 40360
SI A10E AA 01.01	E	3122 785 40370

SERVICE INFORMATION	LANGUAGE	CODE NUMBER
SI A10E DVD-DPL AA 01.01	All	3122 785 40390

SERVICE MANUAL	LANGUAGE	CODE NUMBER
SM A10L AA Supplement (DVD)	GB	3122 785 11520

SERVICE MANUAL	LANGUAGE	CODE NUMBER
SM A10PTV2.0 AA PAL (AP version)	GB	3122 785 10970
SM A10PTV2.0 AA NTSC (AP version)	GB	3122 785 11240

SERVICE MANUAL	LANGUAGE	CODE NUMBER
SM A10PTV2.0 AA (China version)	GB	3122 785 11000

SERVICE MANUAL	LANGUAGE	CODE NUMBER
SM A10PTV2.0 AA NTSC (APversion)	GB	3122 785 11240

SERVICE INFORMATION	LANGUAGE	CODE NUMBER
SI A10PTV2.0 PAL AA 01.01	GB	3122 785 40380

SERVICE MANUAL	LANGUAGE	CODE NUMBER
SM EM1A AA	GB	3122 785 10850
SM EM1A AA NTSC (Taiwan, Korea)	GB	3122 785 11490

SERVICE INFORMATION	LANGUAGE	CODE NUMBER
SI EM1A AA 01.01	GB	3122 785 40330
SI EM1A AA 01.02	GB	3122 785 40400

SERVICE MANUAL	LANGUAGE	CODE NUMBER
SM EM2E AA	GB	3122 785 10310
SM EM2E AA	NL	3122 785 10320
SM EM2E AA	D	3122 785 10330
SM EM2E AA	F	3122 785 10340
SM EM2E AA	I	3122 785 10350
SM EM2E AA	E	3122 785 10360

SERVICE INFORMATION	LANGUAGE	CODE NUMBER
SI EM2E AA 00.01	All	3122 785 40190
SI EM2E AA 00.02	All	3122 785 40290
SI EM2E AA 01.01	All	3122 785 40310

SERVICE MANUAL	LANGUAGE	CODE NUMBER
SM EM1L AA	E	3122 785 11470
SM EM1L AA	Br/Por	3122 785 11480

SERVICE MANUAL	LANGUAGE	CODE NUMBER
SM N8	GB	3122 785 11461

SERVICE MANUAL	LANGUAGE	CODE NUMBER
SM EM3E AA	GB	3122 785 11360
SM EM3E AA	D	3122 785 11370
SM EM3E AA	F	3122 785 11380
SM EM3E AA	I	3122 785 11390
SM EM3E AA	E	3122 785 11400

SERVICE MANUAL	LANGUAGE	CODE NUMBER
SM EM5E AA	GB	3122 785 12560
SM EM5E AA	D	3122 785 12570
SM EM5E AA	F	3122 785 12580
SM EM5E AA	I	3122 785 12590

SERVICE MANUAL	LANGUAGE	CODE NUMBER
SM Receiver-box FTV1.9E AA	GB	3122 785 10160
SM Display-box FTV1.9E AA	GB	3122 785 10170
SM Receiver-box FTV1.9E AA	D	3122 785 10028
SM Display-box FTV1.9E AA	D	3122 785 10029
SM Receiver-box FTV1.9E AA	F	3122 785 10030
SM Display-box FTV1.9E AA	F	3122 785 10031

SERVICE INFORMATION	LANGUAGE	CODE NUMBER
SI Display-box FTV1.9 AA 00.02	GB	3122 785 40170
SI FTV1.9DE AA 00.01	GB	3122 785 40210
SI FTV1.9DE AA 00.02	GB	3122 785 40170
SI FTV1.9EA AA 00.01	GB	3122 785 40200
SI PD4200 N1M (monitor)	GB	3122 785 40150
SI TR4200 N1B/T1B (E-box)	GB	3122 785 40160
SI FTV1.9EE AA 00.01	GB	3122 785 40220
SI FTV1.9E AA 01.01(42PH9932/01S)	All	3122 785 40440

SERVICE MANUAL	LANGUAGE	CODE NUMBER
SM F21RE AA	GB	3122 785 11410
SM F21RE AA	D	3122 785 11420
SM F21RE AA	F	3122 785 11430
SM F21RE AA	I	3122 785 11440
SM F21RE AA	E	3122 785 11450

SERVICE MANUAL	LANGUAGE	CODE NUMBER
SM FM23 AA	GB	3122 785 11300
SM FM23 AA	D	3122 785 11310
SM FM23 AA	F	3122 785 11320
SM FM23 AA	I	3122 785 11330
SM FM23 AA	E	3122 785 11340
SM FM23 AA	Br/Por	3122 785 11350

SERVICE MANUAL	LANGUAGE	CODE NUMBER
SM L01.1A AA (Large Screen)	GB	3122 785 11121

SERVICE MANUAL	LANGUAGE	CODE NUMBER
SM L01.1E AA (Large Screen)	GB	3122 785 11111
SM L01.1E AA (Large Screen)	D	3122 785 11700
SM L01.1E AA (Large Screen)	F	3122 785 11710
SM L01.1E AA (Large Screen)	I	3122 785 11720
SM L01.1E AA (Large Screen)	E	3122 785 11730

SERVICE MANUAL	LANGUAGE	CODE NUMBER
SM L01.1L AA (Large Screen)	GB	3122 785 11140
SM L01.1L AA (Large Screen)	E	3122 785 11791
SM L01.1L AA (Large Screen)	Br/Por	3122 785 11811

Publication survey

SERVICE MANUAL	LANGUAGE	CODE NUMBER
SM L01.1U AA (Large Screen, USA: M8)	GB	3122 785 11170

SERVICE MANUAL	LANGUAGE	CODE NUMBER
SM L01.2A AA (Small Screen)	GB	3162 785 11160

SERVICE MANUAL	LANGUAGE	CODE NUMBER
SM L01.2E AA (Small Screen)	GB	3122 785 11150
SM L01.2E AA (Small Screen)	D	3122 785 11740
SM L01.2E AA (Small Screen)	F	3122 785 11750
SM L01.2E AA (Small Screen)	I	3122 785 11760
SM L01.2E AA (Small Screen)	E	3122 785 11770

SERVICE MANUAL	LANGUAGE	CODE NUMBER
SM L01.2L AA (Small Screen)	GB	3122 785 11180
SM L01.2L AA (Small Screen)	E	3122 785 11800
SM L01.2L AA (Small Screen)	Br/Por	3122 785 11820

SERVICE MANUAL	LANGUAGE	CODE NUMBER
SM L01.2U AA (Small Screen, USA: L8)	GB	3122 785 11130

SERVICE INFORMATION	LANGUAGE	CODE NUMBER
SI L01H.1A AA	GB	3122 785 40420

SERVICE MANUAL	LANGUAGE	CODE NUMBER
SM L01H.1E AA	GB	3122 785 11630

SERVICE INFORMATION	LANGUAGE	CODE NUMBER
SI L01H.2E AA	GB	3122 785 11640

SERVICE MANUAL	LANGUAGE	CODE NUMBER
SM L01H.1L/L01H.2L AA	GB	3122 785 11980
SM L01H.1L/L01H.2L AA	E	3122 785 11990
SM L01H.1L/L01H.2L AA	Br/Por	3122 785 12000

SERVICE MANUAL	LANGUAGE	CODE NUMBER
SM L6.1 AA	GB	4822 727 20901
SM L6.1 AA	NL	4822 727 20903
SM L6.1 AA	D	4822 727 20902
SM L6.1 AA	F	4822 727 20904
SM L6.1 AA	I	4822 727 20905
SM L6.1 AA	E	4822 727 20906

SERVICE INFORMATION	LANGUAGE	CODE NUMBER
SI L6.1 AA 97.02 (3W mono audio ampl.)	GB/NL/D/F/I/E	4822 727 21536

SERVICE MANUAL	LANGUAGE	CODE NUMBER
SM L7.1A AA	GB	4822 727 21497

SERVICE MANUAL	LANGUAGE	CODE NUMBER
SM L9.1A AA	GB	4822 727 21704

SERVICE INFORMATION	LANGUAGE	CODE NUMBER
SI L9.1A AA 00.01	GB	3122 785 40140
SI L9.1A AA 00.02	GB	3122 785 40240

SERVICE MANUAL	LANGUAGE	CODE NUMBER
SM L9.1E AA	GB	4822 727 21677
SM L9.1E AA	NL	4822 727 21678
SM L9.1E AA	D	4822 727 21679
SM L9.1E AA	F	4822 727 21681
SM L9.1E AA	I	4822 727 21682
SM L9.1E AA	E	4822 727 21683
SM L9.1E AB	GB	3122 785 10720
SM L9.1E AB	NL	3122 785 10730
SM L9.1E AB	D	3122 785 10740
SM L9.1E AB	F	3122 785 10750
SM L9.1E AB	I	3122 785 10760
SM L9.1E AB	E	3122 785 10770

SERVICE INFORMATION	LANGUAGE	CODE NUMBER
SI L9.1E AA 00.01	All	3122 785 40130

SERVICE MANUAL	LANGUAGE	CODE NUMBER
SM L9.2A AA	GB	4822 727 21705

SERVICE MANUAL	LANGUAGE	CODE NUMBER
SM L9.2E AA	GB	4822 727 21684
SM L9.2E AA	NL	4822 727 21685
SM L9.2E AA	D	4822 727 21686
SM L9.2E AA	F	4822 727 21687
SM L9.2E AA	I	4822 727 21688
SM L9.2E AA	E	4822 727 21689

SERVICE INFORMATION	LANGUAGE	CODE NUMBER
SI L9.2E AA 00-01		3122 785 40100

SERVICE MANUAL	LANGUAGE	CODE NUMBER
SM L9.3A AA	GB	3122 785 10061

SERVICE MANUAL	LANGUAGE	CODE NUMBER
SM L9.3E AA	GB	3122 785 10370
SM L9.3E AA	NL	3122 785 10380
SM L9.3E AA	D	3122 785 10390
SM L9.3E AA	F	3122 785 10400
SM L9.3E AA	I	3122 785 10410
SM L9.3E AA	E	3122 785 10420

SERVICE MANUAL	LANGUAGE	CODE NUMBER
SM L9H.1A AA	GB	3122 785 10062

SERVICE MANUAL	LANGUAGE	CODE NUMBER
SM L9H.1E AA	GB	3122 785 10064
SM L9H.1E AA	D	3122 785 10190
SM L9H.1E AA	F	3122 785 10200
SM L9H.1E AA	I	3122 785 10210
SM L9H.1E AA	E	3122 785 10220

SERVICE INFORMATION	LANGUAGE	CODE NUMBER
SI L9H.1E AA 01.01	GB,D, F, I, E	3122 785 40470

SERVICE MANUAL	LANGUAGE	CODE NUMBER
SM L9H.2A AA	GB	3122 785 10063

SERVICE MANUAL	LANGUAGE	CODE NUMBER
SM L9H.2E AA	GB	3122 785 10065
SM L9H.2E AA	D	3122 785 10240
SM L9H.2E AA	F	3122 785 10250
SM L9H.2E AA	I	3122 785 10260
SM L9H.2E AA	E	3122 785 10270

SERVICE INFORMATION	LANGUAGE	CODE NUMBER
SI L9H.2E AA 01.01	GB,D, F, I, E	3122 785 40480

SERVICE MANUAL	LANGUAGE	CODE NUMBER
SM L9H.2E AA Supplement on card	GB	3122 785 10600
SM L9H.2E AA Supplement on card	D	3122 785 10610
SM L9H.2E AA Supplement on card	F	3122 785 10620
SM L9H.2E AA Supplement on card	E	3122 785 10640

SERVICE MANUAL	LANGUAGE	CODE NUMBER
SM MD1.1A AA	GB	4822 727 21523
SM MD1.1A BA	GB	4822 727 21663

SERVICE MANUAL	LANGUAGE	CODE NUMBER
SM MD1.2E AA Digital TV	GB	4822 727 21645
SM MD1.2E AA Supplement	GB	4822 727 21498
SM MD1.2E AA Supplement	NL	4822 727 21499
SM MD1.2E AA Supplement	D	4822 727 21501
SM MD1.2E AA Supplement	F	4822 727 21502
SM MD1.2E AA Supplement	I	4822 727 21503
SM MD1.2E AA Supplement	E	4822 727 21504

Publication survey

SERVICE INFORMATION	LANGUAGE	CODE NUMBER
SI MD2.1XE AA 98.01	GB	4822 727 21576
SI MD2.1XE AA 98.01	NL	4822 727 21577
SI MD2.1XE AA 98.01	D	4822 727 21578
SI MD2.1XE AA 98.01	F	4822 727 21579
SI MD2.1XE AA 98.01	I	4822 727 21581
SI MD2.1XE AA 98.01	E	4822 727 21582

SERVICE MANUAL	LANGUAGE	CODE NUMBER
SM MD2.2xE AA	GB	4822 727 21484
SM MD2.2xE AA	NL	4822 727 21485
SM MD2.2xE AA	D	4822 727 21486
SM MD2.2xE AA	F	4822 727 21487
SM MD2.2xE AA	I	4822 727 21488
SM MD2.2xE AA	E	4822 727 21489

SERVICE INFORMATION	LANGUAGE	CODE NUMBER
SI MD2.2xE AA 97.01	GB	4822 727 21537
SI MD2.2xE AA 97.01	NL	4822 727 21538
SI MD2.2xE AA 97.01	D	4822 727 21539
SI MD2.2xE AA 97.01	F	4822 727 21541
SI MD2.2xE AA 97.01	I	4822 727 21542
SI MD2.2xE AA 97.01	E	4822 727 21543
SI MD2.2XE AA 98.01	GB	4822 727 21583
SI MD2.2XE AA 98.01	NL	4822 727 21595
SI MD2.2XE AA 98.01	D	4822 727 21596
SI MD2.2XE AA 98.01	F	4822 727 21597
SI MD2.2XE AA 98.01	I	4822 727 21598
SI MD2.2XE AA 98.01	E	4822 727 21599

SERVICE MANUAL	LANGUAGE	CODE NUMBER
SM MD2.25E AA		4822 727 21611

SERVICE INFORMATION	LANGUAGE	CODE NUMBER
SI MD2.25 AA 98.01		4822 727 21671

SERVICE MANUAL	LANGUAGE	CODE NUMBER
SM MG1.1E AA	GB	3122 785 10150

SERVICE MANUAL	LANGUAGE	CODE NUMBER
SM MG2.1E AA	GB	4822 727 21622
SM MG2.1E AA	NL	4822 727 21623
SM MG2.1E AA	D	4822 727 21624
SM MG2.1E AA	F	4822 727 21625
SM MG2.1E AA	I	4822 727 21626
SM MG2.1E AA	E	4822 727 21627

SERVICE INFORMATION	LANGUAGE	CODE NUMBER
SI MG2.1E AA 99-01	GB	4822 727 21668
SI MG2.1E AA 99-01	NL	4822 727 21698
SI MG2.1E AA 99-01	D	4822 727 21701
SI MG2.1E AA 99-01	F	4822 727 21699
SI MG2.1E AA 99-01	I	4822 727 21702
SI MG2.1E AA 99-01	E	4822 727 21703
SI MG2.1E AA 99-02	GB	3122 785 40001
SI MG2.1E AA 99-02	NL	3122 785 40002
SI MG2.1E AA 99-02	D	3122 785 40003
SI MG2.1E AA 99-02	F	3122 785 40004
SI MG2.1E AA 99-02	I	3122 785 40005
SI MG2.1E AA 99-02	E	3122 785 40006
SI MG2.1E AA 99-03	-	3122 785 40017
SI MG2.1E AA 00.02	All	3122 785 40180
SI MG2.1E/MG3.1E 00.01	All	3122 785 40120
SI MG2.1E AA 00.03 (Design Line)	All	3122 785 40300

SERVICE INFORMATION	LANGUAGE	CODE NUMBER
SI MG2.1E/MG3.1E/MG4.1/MG7.1E	All	3122 785 40280

SERVICE MANUAL	LANGUAGE	CODE NUMBER
SM MG3.1A AA	GB	3122 785 10060

SERVICE MANUAL	LANGUAGE	CODE NUMBER
SM MG3.1E AA	GB	3122 785 10001
SM MG3.1E AA	NL	3122 785 10002
SM MG3.1E AA	D	3122 785 10003
SM MG3.1E AA	F	3122 785 10004
SM MG3.1E AA	I	3122 785 10005
SM MG3.1E AA	E	3122 785 10006

SERVICE MANUAL	LANGUAGE	CODE NUMBER
SM MG3.1U Force	GB	7593

SERVICE INFORMATION	LANGUAGE	CODE NUMBER
SI MG3.1E 99-01	All	3122 785 40018
SI MG3.1E 00-01	All	3122 785 40090
SI MG3.1E AA 01.01	All	3122 785 40410
SI MG2.1E/MG3.1E 00.01	All	3122 785 40120

SERVICE MANUAL	LANGUAGE	CODE NUMBER
SM MG3.2E AA	GB	3122 785 11890
SM MG3.2E AA	D	3122 785 11900
SM MG3.2E AA	F	3122 785 11910
SM MG3.2E AA	I	3122 785 11920
SM MG3.2E AA	E	3122 785 11930

SERVICE MANUAL	LANGUAGE	CODE NUMBER
SM MG4.1E AA	GB	3122 785 10650

SERVICE MANUAL	LANGUAGE	CODE NUMBER
SM MG5.1E AA	GB	3122 785 10016
SM MG5.1E AA	NL	3122 785 10017
SM MG5.1E AA	D	3122 785 10018
SM MG5.1E AA	F	3122 785 10019
SM MG5.1E AA	I	3122 785 10021
SM MG5.1E AA	E	3122 785 10022

SERVICE MANUAL	LANGUAGE	CODE NUMBER
SM MG7.1E AA	GB	3122 785 10780
SM MG7.1E AA	NL	3122 785 10790
SM MG7.1E AA	D	3122 785 10800
SM MG7.1E AA	F	3122 785 10810
SM MG7.1E AA	I	3122 785 10820
SM MG7.1E AA	E	3122 785 10830

Remote control survey

RC TYPE	CODE NUMBER
RC0205/00	4822 218 10681
RC0311/00	4822 219 10098
RC0333/01	3139 148 55140
RC19036002/01	3139 228 88001
RC19039001/01	3139 228 86471
RC19042001/01	3139 228 86482
RC19042002/01	3128 147 13341
RC19335003/01	3139 228 86452
RC19335009/01	3139 228 89251
RC2008/01	4822 219 10695
RC2009/01	4822 219 10578
RC2012/01	3128 147 11811
RC2012/01	3128 147 11811
RC2017/01	3128 147 13331
RC2020/01	3104 207 09540
RC2020/01B	3104 207 09541
RC2030/01	3104 207 09551
RC2031/01	3104 207 09560
RC2031/01B	3104 207 09561
RC2033/01B	3104 207 09581
RC2035/01	3104 207 09601
RC2036/01	3128 147 11721
RC2038/01B	3128 147 12041
RC2042/01	3128 147 12231
RC2043/01B	3128 147 13201
RC2044/01B	3128 147 13651
RC2048/01B	3128 147 13981
RC2511/01	3139 228 84131
RC2525/01	4822 219 10705
RC2532/01	3139 228 82541
RC2533/01	3139 228 82551
RC2541/00	3104 207 08352
RC2541/01	4822 219 10527
RC2543/01	3128 147 12071
RC2563/01	3139 228 84143
RC2576/01	3139 228 86171
RC2592/00	3104 207 09520
RC2592/01B	3104 207 09532
RC282401/01	4822 219 10767
RC282601/01	3139 228 81411
RC282603/01	3139 228 85281
RC282903/01	4822 219 10769
RC282904/01	3139 228 85941
RC283501/01	4822 219 10766
RC283504/01	3139 228 85171
RC283508/01	3139 228 85181
RC283509/01	3139 228 85291
RC283510/01	3139 228 85951
RC2882/01	3139 228 81973
RC2884/00	3139 228 83221
RC2884/01	3139 228 83220
RC2885/01	3139 228 60021
RC8106/01	3139 207 06971
RC8108/01	4822 219 10586
RC8109/01	4822 219 10585
RC8201/01	4822 218 21248
RC8205/01	4822 218 21284
RC8205/21	4822 219 10289
RC8207/01	4822 219 10604
RC8215/01	3128 147 11381
RC86702/01	3139 228 89381
RC86703/01	3139 228 89391
RCL9ED	4822 219 10768
RCL011	3139 128 76291
RCL011_S	3139 128 76321
RCL012	3139 128 76281
RCL013	3139 128 76271
RCL014	3139 228 86471
RCTS1006pronto	3104 207 10321
RG4172BK(T374A)	3135 017 02641
SBHV00020A	3139 128 76011
SBHV00022A	3104 327 00001
SBHV00030A	3104 327 00021

SBHV00032A	3104 327 00031
SBJJ00003A	3139 128 75701
TS1006	3104 207 10322

Tuner survey

TUNER TYPE	CODE NUMBER
ENV56D9863	2422 542 90108
FQ916DMF/PH MK2	4822 210 10634
FQ916DMR/PH MK2	4822 210 10625
FQ916ME/PH MK2	4822 210 10636
FS936E	4822 210 10468
FV916MG/PH	4822 210 10654
TEDE9-004A	4822 210 10853
TEDE9-031A	2422 542 90072
TEDE9-228A	2422 542 90111
TEDE9X002A	2422 542 90066
TEDE9X003A	2422 542 90065
TEDE9X700A	2422 542 90075
TEDE9X029A	2422 542 90067
TEDH9-200A	2422 542 90098
TEDH9-202A	2422 542 90115
TEDH9X001A	4822 210 10854
TEDH9X022A	2422 542 90079
UR1316/A I-3	3139 147 16441
UR1316R/A I -3	3139 147 17402
UV1316/A I U-2	4822 210 10848
UV1316/A I U-3	3139 147 17311
UV1316/A I-2	4822 210 10841
UV1316/A I-3	3139 147 16611
UV1316/A P-3	3139 147 16621
UV1316/A I X U-3	3139 147 18851
UV1316/A I X-3	3139 147 18831
UV1317/A I G-3	3139 147 19171
UV1336B/A P S	3104 147 14911
UV1356A/AIG-3	3139 147 16481
UV915E/MK3	4822 210 10448

CRT survey

CRT TYPE	CODE NUMBER
510UFB22	4822 131 11299
A34AGT11X91	4822 131 11357
A34AGT11X91	4822 131 11357
A34AGT13X95	9322 137 68682
A34AGT13X95E	9322 139 76682
A34AGT14X91	9322 139 31682
A34EAC01X024	4822 131 11367
A34EAC01X113	9301 861 90301
A34EAC11X113	9301 862 00313
A34JLL91X83	9322 146 12682
A36QDT351X01	9322 163 43682
A41EAM40X20	9301 835 40301
A48AGY13X95	9322 137 70682
A48ECR143X18	9322 136 38682
A51EAL/135X15	4822 131 11087
A51EAL155X01	4822 131 11175
A51EAL155X47	4822 131 11105
A51EER133X72	9322 145 31682
A51EFK135X47	9301 842 70329
A51EHW135X47	9301 843 10329
A51ERF135X72	9301 866 80301
A51KPX10X	4822 131 11104
A51KXR95X	4822 131 20581
A51KXR95X01	9322 152 60682
A51KXR95X99	9322 131 77682
A51LSK955X	9322 156 24682
A51LSK955X01	9322 153 82682
A59EAK071X11	4822 131 11184
A59EAK071X44	9301 735 10306
A59EAK552X11	4822 131 20568
A59EEJ71X	4822 131 11368
A59EEJ71X11	4822 131 11366
A59EMZ43X07	9322 147 09682
A59QDF891X001	9322 163 87682
A59QDF891X001(L)	9322 163 87682
A59QDF891X005(L)	9322 164 08682

CRT survey

A66EAK071X01	4822 131 11216
A66EAK071X11	4822 131 11045
A66EAK071X21	9301 731 00346
A66EAK071X44	9301 732 90303
A66EAK552X11	4822 131 20559
A66EAK552X21	9301 721 10346
A66ECF50X05	9322 147 08682
A66EMZ43X07	9322 157 16682
A68AJB82X01	4822 131 20628
A68ERF031X044	9301 831 70301
A68ESF002X111	4822 131 11298
A68ESF002X143	4822 131 11311
A68ESF004X111	9301 811 40314
A68QCP891X001	9322 142 09682
A68QCP891X005	9322 142 10682
A68QCP891X100	8204 000 73341
A68QCP891X101	9322 147 78682
A68QCP891X102	8204 000 73431
A68QCP891X500	9322 160 14682
A68QCP891X500 M169	3104 309 16301
A68QCP891X501	9322 160 15682
A68QCP891X501 M169	3104 309 16311
A68QCP891X502	9322 160 16682
A68QCP891X604	9322 162 09682
A68QCP891X628	9322 177 18682
A68QCP893X001	9322 173 75682
A80ECK272X56	9301 795 00489
A80EJX011X129	8204 000 74831
A80EJX011X429	9322 176 81682
FPF32C106128UA-52	9322 172 11682
FPF42C10660UD-02	4822 135 00193
FPF42C10660UE-11	9322 147 49682
FPF42C10660UE-31	9322 156 44682
M79LQM185X01	9322 156 41682
M79LQM185X02	9322 156 41682
W56ECK001X04	9301 760 20301
W66ECK001X14	4822 131 11345
W66EJU023X815	9322 174 13682
W66ERF001X013	9301 805 90301
W66ERF031X044	9301 828 00306
W66ERF041X044	9301 852 40306
W66ERF042X044	9301 880 70301
W66ESF002X44	4822 131 20704
W76EGV023X315	9322 148 59682
W76EKW10X73	9322 173 93682
W76ERF001X013	9301 800 90314
W76ERF031X044	9301 827 70301
W76ERF041X044	9301 852 00301
W76ERF042X013	9301 880 80314
W76ERF042X044	9301 880 70301
W76ESF031X14	4822 131 11215
W76ESF031X44	4822 131 20705
W86LPX955X	3104 300 50301

Software survey

Tabel 1

Version	Remarks
3104 317 00850	<ul style="list-style-type: none"> - Improved EPG performance <ul style="list-style-type: none"> • Improved acquisition: new acquisition filter (low and high level). Consequence: max. EPG standby time increased to 1 hour • Acquisition start in EPG standby even if no date/time available on local broadcasters • MIP and BI processing done • Improved speed of display update (theme guide) • Message added: 'Programme information can not be displayed on this preset. Select on other preset' (all languages) • Improved reminder start-up: also after power failure in standby

Tabel 2

Version	Remarks
3104 317 01020 3104 317 01030 3104 317 01040	<ul style="list-style-type: none"> - New Auto TV parameters / user Sharpness control improved - New 864 Dolby module added to software - Menu colours / layout changed OSD size reduction (no more icons) - Adopted for the MID2.25 stick remote control RC2000 - Permanent OSD is permanent again: only number! - Bayern Text problem solved - DVD in stead of CDi in the menus - Store PP is moved to Set-up menu; features menu contains now a new item: "Recall Pers. Prefs." - The EasyLink record button now has a 'toggle' function: EasyLink Record and EasyLink Stop. As a consequence, in exceptional situations, sometimes the user has to press this button twice. - 433 cordless Dolby: no Dolby transmission for preset at 359MHz - 1mW or 10mW cordless transmitter selected depending country-choice in menus

Tabel 3

Version	Remarks
3104 317 01240 3104 317 01250 3104 317 01360	<ul style="list-style-type: none"> - P50 standby problem is solved (PR 1679,1764) - Polish Clock problem before 10:00 AM is solved. - Problem with 'WideScreen' aspect-ratio after textDualScreen is solved. - Blanking time when zapping between presets is changed is 3 grades: much shorter for 4:3 TVs, not altered for PAL+ TVs, shorter for the remaining (16:9) types. - A short blanking is introduced when zapping the primary image in Video Dual Screen mode. - East Europe translation problems (inconsistency with manuals) solved. - Mosaic menu line invisible on NTSC image solved. - Entering VGA picture menu with OK button. - 'CDI' in customer service menu 2 added. - Picture performance for DVD is improved: DVD settings work for CVBS, Y/C, and RGB. Changed: Dynamic contrast, Sharpness, Contrast, ANR, Auto TV parameters (CR ER 493, 613). In the set-up menu, the DVD item is altered: the DVD (or other 'Digital Sources') can now be connected to EXT1, 2, 3, or FRONT (used to be only EXT1). The improved picture performance settings will work on the selected connection. - The 'Soft' smart picture mode is altered to give the best possible picture performance for bad quality MPEG signals. - The "information line" item in the set-up menu, is now also functional in permanent OSD mode. - The picture performance of text-dual screen is improved by selecting another font, and shifting the text area a bit away from the picture tube edge. <p>Due to a problem with the set-type determination, this software can not be used in TVs for which the option bit for Smartic is not set, i.e. TVs that do not have the Smartic hardware (Dynamic Contrast). This makes this software unusable as a service-solution for a lot of MID2.2 TVs. All the MID2.25 TV sets do have the Smartic, so this software can be used for MID2.25. The phenomenon in a TV with the Smartic option bit cleared: The screen comes up very dark when switching ON the TV. Pressing the "PP restore" button restores the light-output. After a preset change, the screen is dark again. Pressing "PP restore" restores light.</p>

Software survey

Tabel 4

Version	Remarks
MG2.1E11.0_01561	<ul style="list-style-type: none"> - Subtitle via sub-code gets blocked, solved now - Correctness of clock. Clock accuracy is optimised (deviation 6 sec during 24 hours) - OSD clock update is stumbling. Clock is updated every 0.5 sec now. No further optimisation possible without a serious architecture change. - ACI optimisation , 5 min hang-up during scrambled signals is optimised to 1.5 min - ACI problems in The Netherlands. Sometimes the region table was skipped. The region selection table is always shown now, so the customer needs to select. - ACI problem with Tables on TOP-pages is NOT solved. Broadcaster needs adaptation; TOP table usage is not allowed. - TOP overview corruption of left table is SOLVED - TXT level 2.5 side band colours during vertical expansion; SOLVED - Subtitle skipping of text. This is optimised now - Sound after 4 min EPG-standby. Set doesn't free-up the sound anymore. - EPG sleep timer 2 hours. Set goes into st-by after a reminder wake-up without RC5/RC6 interaction. - EPG reminder wake-up. Sometimes the set doesn't wake-up. Depending on the quality of packet 8/30 wake-ups can go wrong. - Habit watch was not in. Functionality is available now - Next view on M6. Sometimes the TV selects TXT-guide ISO Next View. This is according to spec. Detecting EPG can take max. 2 minutes - Vg2 acknowledge for factory purposes - Hang-up problem; NVM-dump for prod needed for further analyses on hang-ups. - Exception handling to optimise the hang-up behaviour. This has no influence for the customer. - Dealer option store PR is solved

Tabel 5

Version	Remarks
MG2.1E11.3_01611	<ul style="list-style-type: none"> - HOP hardware problem, horizontal jitter. Switch to fast PLL for the N1 HOP version is implemented. - HIP hardware problem, SECAM recognition. The temporarily loss of colour and sync of SECAM signal via SCART is solved. - WSS problem. WSS recognition is disturbed due to a changed spec of MacroVision-protection. The unreliability behaviour of the WSS algorithm is solved. The change only influences the behaviour on SCART. - Slow Status recognition on SCART. The different behaviour of rising and falling edges on the SCART connector is now consistent. This solves strange switching between 4/3 and 16/9 format - OSD text changes for EPG-France; "une fo" becomes "1 fois" and "Journe" becomes "Jour" - OSD text changes in Polish language; "Glosnosc" (Not correctly displayed due to keyboard limitations) and "Wybierz Jezuk" (idem) - Canal+ - M6 EPG problem. When selecting EPG on Canal+, the set switches in the background to M6, which makes the M6 sound available. Switching back to TV-mode makes the set to tune to Canal+ again. MIP page transmission was not possible with the previous SW version. A patch in the Soton SW solves this problem. Now, when selecting EPG on Canal+ no background tuning will happen. ATTENTION: The first time you access EPG transmitted through MIP pages (exp.: Canal+) you need to be tuned during 4 minutes on this channel. This time is required to give the application time to capture the MIP page and store it in NVM. - ACI Veldhoven problem. Cable Distribution company in Veldhoven (the Netherlands) is using transmission pages, which are reserved for TOP table transmission. This is not a common use, but it is allowed according to spec. In this SW version the TOP acquisition is switched OFF during ACI installation, which solves this problem

Software survey

SOFTWARE SURVEY									
CHASSIS	FAMILY	PRODUCTION CODE	UP TYPE/VERSION	IDENT	SERVICE CODE	HOTEL MODE ?	REMARKS TYPICAL FOR THIS SOFTWARE	IDENT	REPLACED BY SERVICE CODE
A10A AA	China, non-TXT	From Wk026 and higher	SAA5645	A10AP1-1.0	9965 000 07276	No	Initial version	A10AP1-1.9	9965 000 07276
A10A AA	China, non-TXT	From Wk029 and higher	SAA5645	A10AP1-1.1	9965 000 07276	No	OSD of the a locked channel is not displayed - TV lock updown channel of CVI - Confirmer switching problem at low signal - PIP OSD position in mode 1,2,3,4 - PIP OSD out of PIP window when in CVI - Dual I/II key problem on external channel - TV lock problem enter access code.	A10AP1-1.9	9965 000 07276
A10A AA	China, non-TXT	From Wk030 and higher	SAA5645	A10AP1-1.3	9965 000 07276	No	HeadPhone plop sound during PIP channel change - Adjust hue(tint) offset for non CVI - After manual store, the sound reset to theater - Hue value in CSM is -50. Whereas in normal mode is 0 - A/CH to toggle RF source to AV source is not working when program list is on - Program list scrolling when av source is skipped problem - Contrast reduction when no video ident - Headphone not mute when OPC_DW_PIP_off.	A10AP1-1.9	9965 000 07276
A10A AA	China, non-TXT	From Wk034 and higher	SAA5645	A10AP1-1.4	9965 000 07276	No	IO expander set / reset SAW filter should be done for all AP region - Double window corruption. - To fix warning message for PIP	A10AP1-1.9	9965 000 07276
A10A AA	China, non-TXT	From Wk034 and higher	SAA5645	A10AP1-1.5	9965 000 07276	No	Audio is muted after the fine tune value in the install submenu is adjusted and stored into A10 DVD.	A10AP1-1.9	9965 000 07276
A10A AA	China, non-TXT	From Wk032 and higher	SAA5645	A10AP1-1.6	9965 000 07276	No	Remove PIP submenu when the option PIPC is OFF - Headphone crosstalk problem - To mute headphone when no signal input and during PIP channel change - Colour could not be detected when plug-in Y/C cable problem	A10AP1-1.9	9965 000 07276
A10A AA	China, non-TXT	From Wk126 and higher	SAA5645	A10AP1-1.8	9965 000 07276	No	Sound is muted after perform fine tuning and stored - White line is seen in 16:9 mode with DVD input for NTSC mode	A10AP1-1.9	9965 000 07276
A10A AA	China, non-TXT	From Wk201+C36 and higher	SAA5645	A10AP1-1.9	9965 000 07276	No		-	-
A10A AA	AP PAL/Multi (57, /69, /73, /79), 10pg TXT	From Wk034 and higher	SAA5667	A10AS1-1.0	9965 000 07277	No	Initial version	A10AS1-1.6	9965 000 7277
A10A AA	AP PAL/Multi (57, /69, /73, /79), 10pg TXT	From Wk040 and higher	SAA5667	A10AS1-1.1	9965 000 07277	No	Teletext clock display - IO expander set / reset SAW filter should be done for all AP region - Double window corruption - Fix warning message for PIP	A10AS1-1.6	9965 000 7277
A10A AA	AP PAL/Multi (57, /69, /73, /79), 10pg TXT	From Wk047 and higher	SAA5667	A10AS1-1.2	9965 000 07277	No	Remove PIP submenu when the option PIPC is OFF - Headphone crosstalk problem - To mute headphone when no signal input and during PIP channel change - Colour could not be detected when plug-in Y/C cable problem	A10AS1-1.6	9965 000 7277
A10A AA	AP PAL/Multi (57, /69, /73, /79), 10pg TXT	From Wk126 and higher	SAA5667	A10AS1-1.4	9965 000 07277	No	White line is seen in 16:9 format with DVD input in NTSC mode.	A10AS1-1.6	9965 000 7277
A10A AA	AP PAL/Multi (57, /69, /73, /79), 10pg TXT		SAA5667	A10AS1-1.6	9965 000 07277	No		-	-
A10A AA	Middle East (56), 10pg TXT	From Wk036 and higher	SAA5667	A10AS2-1.0	9965 000 07281	No	Initial version	A10AS2-1.4	9965 000 7281
A10A AA	Middle East (56), 10pg TXT	From Wk040 and higher	SAA5667	A10AS2-1.1	9965 000 07281	No	IO expander set / reset SAW filter should be done for all AP region - Double window corruption. - To fix warning message for PIP	A10AS2-1.4	9965 000 7281
A10A AA	Middle East (56), 10pg TXT	From Wk047 and higher	SAA5667	A10AS2-1.2	9965 000 07281	No	Remove PIP submenu when the option PIPC is OFF - Headphone crosstalk problem - To mute headphone when no signal input and during PIP channel change - Colour could not be detected when plug-in Y/C cable	A10AS2-1.4	9965 000 7281
A10A AA	Middle East (56), 10pg TXT	From Wk126 and higher	SAA5667	A10AS2-1.3	9965 000 07281	No	Dark page subtitle - Shift down OSD from first row - White line is seen in 16:9 format with DVD input in NTSC mode.	A10AS2-1.4	9965 000 7281
A10A AA	Middle East (56), 10pg TXT		SAA5667	A10AS2-1.4	9965 000 07281	No		-	-
A10A AA	AP PAL/Multi (57, /69, /79) - 100pg	From Wk033 and higher	SAA5667	A10AT1-1.0	9965 000 07282	No	Initial version	A10AT1-1.6	9965 000 07282
A10A AA	AP PAL/Multi (57, /69, /79) - 100pg	From Wk034 and higher	SAA5667	A10AT1-1.1	9965 000 07282	No	Teletext clock display - IO expander set / reset SAW filter should be done for all AP region - Double window corruption. - Fix warning message for PIP	A10AT1-1.6	9965 000 07282
A10A AA	AP PAL/Multi (57, /69, /79) - 100pg	From Wk044 and higher	SAA5667	A10AT1-1.2	9965 000 07282	No	Max cathode drive - Ports controllable by ComPair	A10AT1-1.6	9965 000 07282
A10A AA	AP PAL/Multi (57, /69, /79) - 100pg	From Wk052 and higher	SAA5667	A10AT1-1.3	9965 000 07282	No	Remove PIP submenu when the option PIPC is OFF - Headphone crosstalk	A10AT1-1.6	9965 000 07282
A10A AA	AP PAL/Multi (57, /69, /79) - 100pg	From Wk111 and higher	SAA5667	A10AT1-1.4	9965 000 07282	No	Dark page subtitle - Shift down OSD from first row	A10AT1-1.6	9965 000 07282
A10A AA	AP PAL/Multi (57, /69, /79) - 100pg	From Wk126 and higher	SAA5667	A10AT1-1.5	9965 000 07282	No	White line is seen in 16:9 format with DVD input in NTSC mode.	A10AT1-1.6	9965 000 07282
A10A AA	AP PAL/Multi (57, /69, /79) - 100pg	From Wk201 and higher	SAA5667	A10AT1-1.6	9965 000 07282	No		-	-
A10A AA	Middle East PAL/Multi (56), 100pg	From Wk037 and higher	SAA5667	A10AT2-1.0	9965 000 07283	No	Initial version	A10AT2-1.4	9965 000 07283
A10A AA	Middle East PAL/Multi (56), 100pg	From Wk040 and higher	SAA5667	A10AT2-1.1	9965 000 07283	No	IO expander set / reset SAW filter should be done for all AP region - Double window corruption. - Fix warning message for PIP	A10AT2-1.4	9965 000 07283
A10A AA	Middle East PAL/Multi (56), 100pg	From Wk052 and higher	SAA5667	A10AT2-1.2	9965 000 07283	No	Dark page subtitle (P801) - Shift down OSD from first row - White line is seen in 16:9 format with DVD input in NTSC mode.	A10AT2-1.4	9965 000 07283
A10A AA	Middle East PAL/Multi (56), 100pg	From Wk126 and higher	SAA5667	A10AT2-1.3	9965 000 07283	No		-	-
A10A AA	Middle East PAL/Multi (56), 100pg	From Wk201 and higher	SAA5667	A10AT2-1.4	9965 000 07283	No		-	-

Software survey

SOFTWARE SURVEY									
CHASSIS	FAMILY	PRODUCTION CODE	UP TYPE/VERSION	IDENT	SERVICE CODE	HOTEL MODE ?	REMARKS TYPICAL FOR THIS SOFTWARE	IDENT	REPLACED BY
A10A AA	AP-NTSC (71, 97)	From Wk037 and higher	SAAS645	A10AN1-1.1	9965 000 07284	No	Initial version	A10AN1-1.6	9965 000 07284
A10A AA	AP-NTSC (71, 97)	From Wk107 and higher	SAAS645	A10AN1-1.3	9965 000 07284	No	Only mono sound can be heard upon mains ON - Headphone crosstalk problem	A10AN1-1.6	9965 000 07284
A10A AA	AP-NTSC (71, 97)	From Wk126 and higher	SAAS645	A10AN1-1.5	9965 000 07284	No	White line is seen in DVD 16:9 mode.	A10AN1-1.6	9965 000 07284
A10A AA	AP-NTSC (71, 97)	From Wk201 and higher	SAAS645	A10AN1-1.6	9965 000 07284	No		-	-
A10A AA	AP-NTSC (61), non-TXT, CC	From Wk037 and higher	SAAS645	A10AN2-1.1	9965 000 07285	No	Initial version	A10AN2-1.6	9965 000 07285
A10A AA	AP-NTSC (61), non-TXT, CC	From Wk111 and higher	SAAS645	A10AN2-1.2	9965 000 07285	No	Cancel all timer when hospitality mode is entered - Close Caption does not display after setting it to ON - Close Caption display problem in CVI mode - Lock icon can be seen in program list when CHLK is OFF - Left side of the screen is unblanked in blocked channel when sleeper is ON and Close Caption is ON - Last status of sound detection - Error 16 & 13 reported in SDM when shorting SDM pins - Hospitality mode reset problem - No sound on channel 6 via headphone	A10AN2-1.6	9965 000 07285
A10A AA	AP-NTSC (61), non-TXT, CC	From Wk126 and higher	SAAS645	A10AN2-1.5	9965 000 07285	No	White line is seen in DVD 16:9 mode.	A10AN2-1.6	9965 000 07285
A10A AA	AP-NTSC (61), non-TXT, CC	From Wk201 and higher	SAAS645	A10AN2-1.6	9965 000 07285	No		-	-
A10A AA	AP PAL/Multi (57, 69, 79) 100pg	From Wk041 and higher	SAAS667	A10ADT1-1.0	9965 000 07286	No	Initial version	A10ADT1-1.5	9965 000 07286
A10A AA	AP PAL/Multi (57, 69, 79) 100pg	From Wk044 and higher	SAAS667	A10ADT1-1.1	9965 000 07286	No	Headphone mute when RF has no signal - "X" not shown when RC5 INCR, SURR pressed in DVD mode	A10ADT1-1.5	9965 000 07286
A10A AA	AP PAL/Multi (57, 69, 79) 100pg	From Wk111 and higher	SAAS667	A10ADT1-1.4	9965 000 07286	No	Dark page subtitle problem - Shift down OSD from first row	A10ADT1-1.5	9965 000 07286
A10A AA	AP PAL/Multi (57, 69, 79) 100pg	From Wk126 and higher	SAAS667	A10ADT1-1.5	9965 000 07286	No	White line is seen in DVD 16:9 mode.	-	-
A10E AA	W.Europe, 10 page TXT	Production start	SAAS565M3	A10ET1-1.0	n.a.	No	Initial version	A10ET1-1.7	3111 250 54511
A10E AA	W.Europe, 10 page TXT	Production	SAAS565M3	A10ET1-1.1	9352 677 14557	No		A10ET1-1.7	3111 250 54511
A10E AA	W.Europe, 10 page TXT	from Wk 032	SAAS565M3	A10ET1-1.2	n.a.	No		A10ET1-1.7	3111 250 54511
A10E AA	W.Europe, 10 page TXT	from Wk 034	SAAS565M3	A10ET1-1.3	9352 681 58557	No		A10ET1-1.7	3111 250 54511
A10E AA	W.Europe, 10 page TXT	from Wk 036	SAAS565M3	A10ET1-1.4	3111 250 54511	No		A10ET1-1.7	3111 250 54511
A10E AA	W.Europe, 10 page TXT	from Wk 128	SAAS565M3	A10ET1-1.6	3111 250 54511	No	Solving of embarrassing Mute in EXT1 when DVD connected	A10ET1-1.7	3111 250 54511
A10E AA	W.Europe, 10 page TXT	from Wk 204	SAAS565M3	A10ET1-1.7	3111 250 54511	No	Solving of DST issue	A10ET1-1.7	3111 250 54511
A10E AA	W.Europe, 100 page TXT	Production start	SAAS667	A10EP1-1.1	n.a.	No		A10EP1-1.6	3111 250 54501
A10E AA	W.Europe, 100 page TXT	from Wk 036	SAAS667	A10EP1-1.3	3111 250 54501	No		A10EP1-1.6	3111 250 54501
A10E AA	W.Europe, 100 page TXT	from Wk 116	SAAS667	A10EP1-1.4	3111 250 54501	No		A10EP1-1.6	3111 250 54501
A10E AA	W.Europe, 100 page TXT		SAAS667	A10EP1-1.6	3111 250 54501	No		-	-
A10E AA	E.Europe, 100 page TXT	Prod. start from Wk 040	SAAS667	A10EP2-1.0	9965 000 07287	No	Initial version	A10EP2-1.2	9965 000 07287
A10E AA	E.Europe, 100 page TXT		SAAS667	A10EP2-1.2	9965 000 07287	No		-	-
A10E AA DPL	W.Europe, 100 page TXT	Prod. Start from Wk 039	SAAS667	A10ED1-1.0	9965 000 10425	No	Initial version	A10ED1-1.2	9965 000 10425
A10E AA DPL	W.Europe, 100 page TXT	Prod. Start from Wk 128	SAAS667	A10ED1-1.2	9965 000 10425	No	Initial version	-	-
A10E AA DPL	E.Europe, 100 page TXT		SAAS667	A10ED2-1.0	9965 000 07288	No	Initial version	-	-
A10E AA DVD	W.Europe, 100 page TXT	Prod. Start from Wk 115	SAAS667	A10EDN1-1.1	9965 000 10426	No	Initial version	A10EDN1-1.9	9965 000 10426
A10E AA DVD	W.Europe, 100 page TXT	Prod. Start from Wk 126	SAAS667	A10EDN1-1.2	9965 000 10426	No		A10EDN1-1.9	9965 000 10426
A10E AA DVD	W.Europe, 100 page TXT	Prod. Start from Wk 133	SAAS667	A10EDN1-1.3	9965 000 10426	No		A10EDN1-1.9	9965 000 10426
A10E AA DVD	W.Europe, 100 page TXT	Prod. Start from Wk 137	SAAS667	A10EDN1-1.5	9965 000 10426	No		A10EDN1-1.9	9965 000 10426
A10E AA DVD	W.Europe, 100 page TXT	Prod. Start from Wk 208	SAAS667	A10EDN1-1.9	9965 000 10426	No		-	-
A10E AA DVD+DPL	W.Europe, 100 page TXT	Prod. Start from Wk 135	SAAS667	A10EDD1-1.0	9965 000 12349	No	Initial version	A10EDD1-1.3	9965 000 12349
A10E AA DVD+DPL	W.Europe, 100 page TXT	Prod. Start from Wk 208	SAAS667	A10EDD1-1.3	9965 000 12349	No		-	-
A10E AA DVD+DPL	E.Europe, 100 page TXT	Prod. Start from Wk 135	SAAS667	A10EVD1-1.0	9965 000 12350	No	Initial version	-	-
A10E AA DVD+DPL	E.Europe, 100 page TXT	Prod. Start from Wk 208	SAAS667	A10EVD1-1.3	9965 000 12350	No	Initial version	-	-
A10-PTV2.0	AP		SAAS667	PTV 2AP1 V2.23	-	No		-	-
A10-PTV2.0	AP		SAAS667	PTV 2AP1 V2.51	-	No		-	-
A10-PTV2.0	Taiwan/Philippines		SAAS667	PTV 3AP1 V2.23	-	No		-	-
A10-PTV2.0	Taiwan/Philippines		SAAS667	PTV 3AP1 V2.28	-	No		-	-
A10-PTV2.0	Korea		SAAS667	PTV 3AP2 V2.24	-	No		-	-
A10-PTV2.0	Korea		SAAS667	PTV 3AP2 V2.28	-	No		-	-
EM1A	1AP1 (93)	From week 0037	SAAS647HL/M1	EM11A1_1_3_02601	9965 000 07279	No		EM11A1_1.5_02631	9965 000 07279
EM1A	1AP1	From week 0042	SAAS647HL/M1	EM11A1_1_5_02631	9965 000 07279	No		EM11A1_1.9_02771	9965 000 07279
EM1A	1AP1	From week 0102	SAAS647HL/M1	EM11A1_1_9_02771	9965 000 07279	No		EM11A1_2.0_02871	3104 317 02871
EM1A	1AP1	From week 0105	SAAS647HL/M1	EM11A1_2.0_02871	3104 317 02871	No		EM11A1_2.1_02921	3104 317 02921

Software survey

SOFTWARE SURVEY										REPLACED BY	
CHASSIS	FAMILY	PRODUCTION CODE	UP TYPE/VERSION	IDENT	SERVICE CODE	HOTEL MODE ?	REMARKS TYPICAL FOR THIS SOFTWARE	IDENT	SERVICE CODE		
EM1A	1AP1	From week 0109	SAA5647HL/M1	EM11A1_2.1_02921	3104.317.02921	No		EM11A1_2.4_03261	3104.317.03261		
EM1A	1AP1	From week 0128	SAA5647HL/M1	EM11A1_2.4_03261	3104.317.03261	No	New MSP B8-version (AG01).				
EM1A	1AP1	From week 0203	SAA5647HL/M1	EM11A1_3.0_03571	3104.317.03571	No	Solution for: microphone (reduced bass-settings).				
EM1A	2AP1 (57, 69, /75, /79)	From week 0037	SAA5647HL/M1	EM12A1_1.3_02611	3104.317.02611	No		EM12A1_1.6_02641	3104.317.02641		
EM1A	2AP1	From week 0046	SAA5647HL/M1	EM12A1_1.6_02641	3104.317.02641	No		EM12A1_1.9_02781	3104.317.02781		
EM1A	2AP1	From week 0051	SAA5667HL/M1	EM12A1_1.9_02781	3104.317.02781	No		EM12A1_2.0_02881	3104.317.02881		
EM1A	2AP1	From week 0105	SAA5667HL/M1	EM12A1_2.0_02881	3104.317.02881	No		EM12A1_2.1_02931	3104.317.02931		
EM1A	2AP1	From week 0109	SAA5667HL/M1	EM12A1_2.1_02931	3104.317.02931	No		EM12A1_2.4_03271	3104.317.03271		
EM1A	2AP1	From week 0128	SAA5667HL/M1	EM12A1_2.4_03271	3104.317.03271	No	New MSP B8-version (AG01).				
EM1A	2AP1	From week 0204	SAA5667HL/M1	EM12A1_3.0_03561	3104.317.03561	No	Solution for: microphone (reduced bass-settings).				
EM1A	2AP2 (56, /69)	From week 0102	SAA5667HL/M1	EM12A2_1.9_02791	3104.317.02791	No		EM12A2_2.0_02891	3104.317.02891		
EM1A	2AP2	From week 0105	SAA5667HL/M1	EM12A2_2.0_02891	3104.317.02891	No		EM12A2_2.4_03281	3104.317.03281		
EM1A	2AP2	From week 0128	SAA5667HL/M1	EM12A2_2.4_03281	3104.317.03281	No	New MSP B8-version (AG01).				
EM1A-NTSC	3AP1 (Taiwan, /71)	From week 0133	SAA5677HL/M1	EM13A1_1.1_03321	3104.317.03321	No		EM13A1_1.2_03351	3104.317.03351		
EM1A-NTSC	3AP1	From week 0134	SAA5677HL/M1	EM13A1_1.2_03351	3104.317.03351	No		EM13A1_1.3_03371	3104.317.03371		
EM1A-NTSC	3AP1	From week 0135	SAA5677HL/M1	EM13A1_1.3_03371	3104.317.03371	No					
EM1A-NTSC	3AP2 (Korea, /61)	From week 0133	SAA5677HL/M1	EM13A2_1.1_03331	3104.317.03331	No		EM13A2_1.2_03361	3104.317.03361		
EM1A-NTSC	3AP2	From week 0134	SAA5677HL/M1	EM13A2_1.2_03361	3104.317.03361	No		EM13A2_1.3_03381	3104.317.03381		
EM1A-NTSC	3AP2	From week 0135	SAA5677HL/M1	EM13A2_1.3_03381	3104.317.03381	No					
EM1L	1LT1 (/77)	From week 0126	SAA5677HL/M1	EM11L1_1.1_03401	3104.317.03401	No					
EM1L	2LT1 (/44, /65, /78)	From week 0136	SAA5677HL/M1	EM12L1_1.2_03411	3104.317.03411	No					
N8	2US1 (/17)	From week 0126	SAA5677HL/M1	EM12U1_2.0_03251	3104.317.03251	No		EM12U1_2.1_03291	3104.317.03291		
N8	2US1	From week 0132	SAA5677HL/M1	EM12U1_2.1_03291	3104.317.03291	No		EM12U1_2.2_03391	3104.317.03391		
N8	2US1	From week 0135	SAA5677HL/M1	EM12U1_2.2_03391	3104.317.03391	No					
N8 (DL)	3US1 (/17)	From week 0140	SAA5677HL/M1	EM13U1_1.3_03461	3104.317.03461	No					
EM1*	FBX	From week 0007		EMG_REP1_02221	3104.317.42221	No					
EM1*	FBX	From week 0012		EMG_REP2_02341	3104.317.42341	No					
EM1*	FBX	From week 0027		EMG_REP3_02491	3104.317.42491	No					
EM1L, EM1A-NTSC	FBX	From week 0042		EMG_RMERGE1_02741	3104.317.42741	No					
EM1A	FBX	From week 0112		EMG_RMERGE2_02991	3104.317.42991	No					
N8	FBX	From week 0112		EMG_RMERGE3_03241	3104.317.43241	No					
EM2E	uP	Production start (AG00)		EM2E11.0_02211	9965.000.07280	No			9965.000.07280		
EM2E	uP	From week 0014		EM2E11.1_02331	9965.000.07280	No	Solution for: EPG problem, wrong surround-mode indication, blank & mute at start-up, MSP option string adapted for introduction of DBE.		9965.000.07280		
EM2E	uP	From week 0015		EM2E11.2_02371	9965.000.07280	No	Acoustical settings FL12-cabinet, solution for error with default objects.		9965.000.07280		
EM2E	uP	From week 0016		EM2E11.3_02381	9965.000.07280	No	Solution for: Tuner_prot, HFB_prot and Flash_prot does not work, wrong errorcode (5.iso.4) when no 5V, EPG Dual Screen shifted too much upward.		9965.000.07280		
EM2E	uP	From week 0021		EM2E11.4_02391	9965.000.07280	No	Solution for: unpredictable start-up behaviour after STBY, Italian menu translation, last status preset not recalled, several EPG/TXT problem.		9965.000.07280		
EM2E	uP	From week 0025		EM2E11.5_02431	9965.000.07280	No	Solution for: no wake-up via PC, display of operation hours, DBE settings added, separate IF AFC adjustment added for SECAM L', problem with manual channel search, EPG2 hang-up, SW made compatible for HDP-N3		9965.000.07280		
EM2E	uP	From week 0034		EM2E11.6_02521	9965.000.07280	No	Solution for: blocked set going to TXT Dual Screen, Options adapted for Real Flat and acoustical settings added for FL9DAS and FL12RF.		9965.000.07280		
EM2E	uP	From week 0104		EM2E11.7_02531	9965.000.07280	No	Solution for: headphone volume problem, hollow image in TXT-DS, store LS vertical shift. Several improvements for channel search and ACL, blanking in 4:3 mode.		9965.000.07280		
EM2E	uP	From week 0116		EM2E11.8_02971	9965.000.07280	No					
EM2E	uP	From week 0119 (AG23)		EM2E11.9_03061	3104.317.03061	No	Only for RF sets (AG23). Solution for: vertical shift problem and moiré.				
EM2	FBX	Production start (0012)		EMG_REP2_02341	3104.317.42341	No					
EM2	FBX	From week 0112		EMG_RMERGE2_02991	3104.317.42991	No					

Software survey

SOFTWARE SURVEY										
CHASSIS	FAMILY	PRODUCTION CODE	UP TYPE/VERSION	IDENT	SERVICE CODE	HOTEL MODE ?	REMARKS TYPICAL FOR THIS SOFTWARE	IDENT	REPLACED BY SERVICE CODE	
EM3E	UP	Production start (0124)		EM3E11.0-03041	3104.317.03041	No		EM3E11.2_00311	3104.317.03311	
EM3E	UP	From week 0133		EM3E11.2-03311	3104.317.03311	No	Some bugs solved in the 'Double lines' mode.	EM3E11.3-03431	3104.317.03431	
EM3E	UP	From week 0137		EM3E11.3-03431	3104.317.03431	No	Two I2C-busses i.s.o. one. Set Typenumber in CSM. CSM-entry via 123654-code			
EM3E	FBX	Production start (0106)		EMGS_FBX_02951	3104.317.42951	No		EMGS_FBX_03441	3104.317.43441	
EM3E	FBX	From week 0142		EMGS_FBX_03441	3104.317.43441	No	Solution for: Color problems in NTSC			
F21RE	Ebox-SSP			F21RE1_1.0_V00247	3122.357.40247			F21RE1_1.1_V00248	3122.357.40248	
F21RE	Ebox-SSP			F21RE1_1.1_V00248	3122.357.40248					
F21RE	Ebox-FBX			V1.3	3122.357.40134			X6F2V13_V1.3	3122.357.40234	
F21RE	Ebox-FBX			X6F2V13_V1.3	3122.357.40234					
FM23	Monitor-OTC			FM23GB-1.2-00273	3122.357.00273			FM23GB-1.3-00274	3122.357.00274	
FM23	Monitor-OTC			FM23GB-1.3-00274	3122.357.00274					
FM23	Monitor-P.W.			FM23GB-1.2-00263	3122.357.00263			FM23GB-1.3-00264	3122.357.00264	
FM23	Monitor-P.W.			FM23GB-1.3-00264	3122.357.00264					
FM23	Monitor-EPLD			FM23GB1000023	3122.357.00283			FM23GB2400024	3122.357.00284	
FM23	Monitor-EPLD			FM23GB2400024	3122.357.00284					
FM23	Monitor-DDC 7904				3122.357.00301					
FM23	Monitor-DDC 7907				3122.357.00311					
FTV1.9DE	Monitor	Start production		F19DW2.0_00071	3122.357.40021	No		F19DW2.0_00074	3122.357.40024	
FTV1.9DE	Monitor	AG01 and higher		F19DW2.0_00072	3122.357.40022	No	PDP-Limesco position 7357	F19DW2.0_00074	3122.357.40024	
FTV1.9DE	Monitor	AG02 and higher, week 9948 and higher		F19DW2.0_00074	3122.357.40024	No	PDP-Limesco position 7357, introduction Y/C panel - not in TV configuration	F19DW2.0_00075	3122.357.40025	
FTV1.9DE	Monitor	AG06 and higher, week 0018 and higher		F19DG1.0_00131	3122.357.40081	No	PDP-Limesco position 7357 - only in TV-configuration			
FTV1.9DE	Monitor	AG07 and higher, week 0027 and higher		F19DW2.0_00075	3122.357.40025	No	PDP-Limesco position 7357 - introduction SW for Monitor- & TV-configuration			
FTV1.9DE	Monitor	Start production		F19DE11.1_00062	3122.357.40042	No	MUP Panel .1 version - position 7001	F19DE12.0_00063	3122.357.40043	
FTV1.9DE	Monitor	AG02 and higher, week 9948 and higher		F19DE12.0_00063	3122.357.40043	No	MUP Panel .2 version - position 3018 added - to be used with PDP-OTP 3122.357.40024	F19DE12.1_00064	3122.357.40044	
FTV1.9DE	Monitor	From week 9950 and higher		F19DE12.1_00064	3122.357.40044	No	Only for monitors - to be used with PDP-OTP 3122.357.40024, improvement of introduction SW for Monitor- & TV-config, SW with option numbers for Y/C board and sound enable available	F19DE12.1_00065	3122.357.40045	
FTV1.9DE	Monitor	AG06 and higher, week 0018 and higher		F19DE12.1_00065	3122.357.40045	No	Update for Marantz & 16:9 aspect ratio	F19DE14.0_00066	3122.357.40046	
FTV1.9DE	Monitor	AG07 and higher, week 0027 and higher		F19DE14.0_00066	3122.357.40046	No				
FTV1.9DE	Monitor	AG07 and higher, week 0027 and higher		F19DE15.0_00068	3122.357.40048	No				
FTV1.9DE	Monitor	Production start (9935)		EAROM_00091	3122.357.40051	No	AVC position 7400	EAROM_00092	3122.357.40052	
FTV1.9DE	Monitor	From week 9948		EAROM_00092	3122.357.40052	No	AVC position 7400 - AG02 code - introduction Y/C panel	EAROM_00095	3122.357.40055	
FTV1.9DE	Monitor	From week 0018		EAROM_00095	3122.357.40055	No	AVC position 7400 - AG06 code - introduction SW for Monitor- & TV-config.			
FTV1.9EE	E-Box, FBX4			FBX4V1.5	3104.317.01211	No		FTV1.9_00112	3122.357.40062	
FTV1.9EE	E-Box, FBX6			FTV1.9_00111	3122.357.40061	No		FTV1.9_00112	3122.357.40062	
FTV1.9EE	E-Box, FBX6			M27C512-90-C1	3122.357.40062	No				
FTV1.9EE	E-Box, FBX4 - West Europe	Start production		F19EE11.2_00052	3122.357.40052	No		F19EE11.3_00054	3122.357.40054	
FTV1.9EE	E-Box, FBX4 - West Europe	AG01 and higher, week 9948 and higher		F19EE11.2_00053	3122.357.40053	No		F19EE11.3_00054	3122.357.40054	
FTV1.9EE	E-Box, FBX4 - West Europe	AG02 and higher, week 0018 and higher		F19EE11.3_00054	3122.357.40054	No	Solved switching problem between 2CS and NICAM	F19EE4.0_00055	3122.357.40055	
FTV1.9EE	E-Box, FBX6 - West Europe			F19EE4.0_00055	3122.357.40055	No	SSP position 7202 - /125 /195 /585			
FTV1.9EE	E-Box, FBX6 - East Europe			F19ECA.1_00201	3122.357.40111	No	SSP position 7202 - /585			
FTV1.9EE	E-Box, FBX6 - West Europe			F19EE4.1_00211	3122.357.40121	No	SSP position 7202 - /125 & /195			
FTV1.9EE	E-Box - USA			F19EU12.0_00141	3122.357.40071	No	To be used in combination with monitor software from AG06	F19EU12.1_00143	3122.357.40073	

Software survey

SOFTWARE SURVEY

CHASSIS	FAMILY	PRODUCTION CODE	UP TYPE/VERSION	IDENT	SERVICE CODE	HOTEL MODE ?	REMARKS TYPICAL FOR THIS SOFTWARE	IDENT	REPLACED BY SERVICE CODE
FTV1.9EE	E-Box - USA	AG03 and higher, week 0022 and higher	M27C801-1/00F1	F19EU12.0_00142	3122 357 40072	No	To be used in combination with monitor software from AG06	F19EU12.1_00143	3122 357 40073
FTV1.9EE	E-Box - USA	AG03 and higher, week 0022 and higher	M27C801-1/00F1	F19EU12.1_00143	3122 357 40073	No	To be used in combination with monitor software from AG06 - unwanted sound mulling solved	F19EU14.1_00144	3122 357 40074
FTV1.9EE	E-Box - USA	Week 0040 and higher	M27C801-1/00F1	F19EU14.1_00144	3122 357 40074	No		F19EA14.1_00163	3122 357 40093
FTV1.9EE	E-Box - AP		M27C801-1/00F1	F19EA13.0_00161	3122 357 40091	No			
FTV1.9EE	E-Box - AP		M27C801-1/00F1	F19EA14.1_00163	3122 357 40093	No			
FTV1.9EE	E-Box - Marantz		M27C801-1/00F1	F19EM14.1_00181	3122 357 40101	No		F19EM14.1_00182	3122 357 40102
FTV1.9EE	E-Box - Marantz		M27C801-1/00F1	F19EM14.1_00182	3122 357 40102	No			
L01.1A	Philippines - No Text		TDA9580H/N1/3/0388	TDA9580_L01AC11.5	9352 693 90557				
L01.1A	Taiwan, Philippines - No Text		TDA9588H/N1/3/0408	TDA9588_L01AC11.5	9352 694 11557				
L01.1A	Spore, NZ, Aust - 10 page Text		TDA9565H/N1/4	TDA9565_L01AT11.3	9352 695 11557			TDA9565_L01AT11.6	9352 693 77557
L01.1A	Spore, NZ, Aust - 10 page Text		TDA9565H/N1/4/0378	TDA9565_L01AT11.6	9352 693 77557				
L01.1A	Spore, NZ, Aust - 10 page Text		TDA9565H/N1/4/0631	TDA9565_L01AT12.4	9352 707 07557				
L01.1A	Spore, NZ, Aust - 10 page Text		TDA9567H/N1/4/0382	TDA9567_L01AT11.6	9352 693 81557				
L01.1A	Spore, NZ, Aust - 10 page Text		TDA9567H/N1/4/0632	TDA9567_L01AT12.4	9352 707 08557				
L01.1A	Middle East - 10 Page Text		TDA9565H/N1/4	TDA9565_L01AT21.0	9352 693 78557			TDA9565_L01AT21.2	9352 693 78557
L01.1A	Middle East - 10 Page Text		TDA9565H/N1/4/0379	TDA9565_L01AT21.2	9352 693 78557				
L01.1A	Middle East - 10 Page Text		TDA9565H/N1/4/0634	TDA9565_L01AT22.4	9352 707 10557				
L01.2A	Asian Pacific - No Text		TDA9581H/N1/3/0392	TDA9581_L01AN21.7	9352 693 94557				
L01.2A	Asian Pacific - No Text		TDA9581H/N1/3/0623	TDA9581_L01AN22.2	9352 706 99557				
L01.2A	Middle East - No Text		TDA9582H/N1/3/0396	TDA9582_L01AN21.0	9352 693 96557				
L01.2A	Middle East - No Text		TDA9582H/N1/3/0626	TDA9582_L01AN22.2	9352 707 02557				
L01.2A	Middle East, Pakistan, S. Africa, Zimbabwe - No Text		TDA9582H/N1/3/0629	TDA9582_L01AN92.2	9352 707 05557				
L01.2A	AP - Text		TDA9561H/N1/4/0373	TDA9561_L01AT11.6	9352 693 66557				
L01.2A	AP - Text		TDA9561H/N1/4/0630	TDA9561_L01AT12.4	9352 707 37557				
L01.2A	AP, Pakistan - 10 Page Text		TDA9567H/N1/4/0383	TDA9567_L01AT21.2	9352 693 82557				
L01.2A	AP, Pakistan - 10 Page Text		TDA9567H/N1/4/0635	TDA9567_L01AT22.4	9352 707 11557				
L01.1E	West Europe - 10 Page Text	Wk120.2 or higher	TDA9565N1/5/0381	TDA9565_L01EF11.7	9352 693 80557			TDA9565_L01EF11.9	9352 698 96557
L01.1E	West Europe - 10 Page Text	Wk124.4 or higher	TDA9565N1/5/0466	TDA9565_L01EF11.9	9352 698 96557				
L01.1E	West Europe - 10 Page Text	Wk140.3 or higher	TDA9565N1/5/0579	TDA9565_L01EF12.2	9352 704 32557		Main solved issues : NVM deprogrammation, Erratic character in AV source, German translation correction.		
L01.1E	East Europe - 10 Page Text	Wk120.2 or higher	TDA9565N1/5/0648	TDA9565_L01EF13.1	9352 707 67557				
L01.1E	East Europe - 10 Page Text	Wk124.4 or higher	TDA9563H/N1/5/0377	TDA9563_L01EF21.5	9352 693 76557			TDA9563_L01EF21.7	9352 698 98557
L01.1E	East Europe - 10 Page Text	Wk124.4 or higher	TDA9563H/N1/5/0468	TDA9563_L01EF21.7	9352 698 98557				
L01.1E	East Europe - 10 Page Text	Wk140.3 or higher	TDA9563H/N1/5/0582	TDA9563_L01EF22.2	9352 704 38557		Main solved issues : NVM deprogrammation, Erratic character in AV source, German translation correction.		
L01.1E	East Europe - 10 Page Text		TDA9563H/N1/5/0739	TDA9563_L01EF23.1	9352 712 22557				
L01.1E	East Europe - 10 Page Text	Wk150 or higher	TDA9555H/N1/3/0667	TDA9555_L01ET01.1	9352 708 92557		Initial version		
L01.1E	East/West Europe - 1 Page Text		TDA9555H/N1/3	TDA9555_L01ET151.X	9352 694 43557		Initial version		
L01.2E	West Europe - 10 Page Text	Wk120.2 or higher	TDA9561H/N1/5/0375	TDA9561_L01EF11.7	9352 693 74557			TDA9561_L01EF11.9	9352 698 97557
L01.2E	West Europe - 10 Page Text	Wk124.4 or higher	TDA9561H/N1/5/0467	TDA9561_L01EF11.9	9352 698 97557				
L01.2E	West Europe - 10 Page Text	Wk140.3 or higher	TDA9561H/N1/5/0581	TDA9561_L01EF12.2	9352 704 34557				
L01.2E	West Europe - 10 Page Text	Wk120.2 or higher	TDA9567H/N1/5/0385	TDA9567_L01EF11.7	9352 693 87557			TDA9567_L01EF11.9	9352 698 95557
L01.2E	West Europe - 10 Page Text	Wk124.4 or higher	TDA9567H/N1/5/0465	TDA9567_L01EF11.9	9352 698 95557				
L01.2E	West Europe - 10 Page Text	Wk140.3 or higher	TDA9567H/N1/5/0580	TDA9567_L01EF12.2	9352 704 33557				

SOFTWARE SURVEY										
CHASSIS	FAMILY	PRODUCTION CODE	UP TYPE/VERSION	IDENT	SERVICE CODE	HOTEL MODE ?	REMARKS TYPICAL FOR THIS SOFTWARE	IDENT	REPLACED BY SERVICE CODE	
L01.2E	West Europe - 10 Page Text		TDA9567H/N1/5/0651	TDA9567 L01EF13.1	9352 707 70557		Main solved issues : NVM deprogrammation, Erratic character in AV source, German translation correction.			
L01.2E	East Europe - 10 Page Text	Wk120.2 or higher	TDA9561H/N1/0376	TDA9561 L01EF21.5	9352 693 75557			TDA9561 L01EF21.7	9352 698 99557	
L01.2E	East Europe - 10 Page Text	Wk124.4 or higher	TDA9561H/N1/0469	TDA9561 L01EF21.7	9352 698 99557					
L01.2E	East Europe - 10 Page Text	Wk140.3 or higher	TDA9561H/N1/0578	TDA9561 L01EF22.2	9352 704 31557					
L01.2E	East Europe - 10 Page Text		TDA9561H/N1/5/0740	TDA9561 L01EF22.3	9352 712 23557					
L01.2E	EastWest Europe - 1 Page Text		TDA9552H/N1/3/0668	TDA9552 L01ET51.1	9352 708 93557					
L01.2E	EastWest Europe - 1 Page Text		TDA9552H/N1/3/0668	TDA9552 L01ET51.5	9352 712 24557					
L01H.1E	EU		TDA9555H/N1/3/0608	L01HE1-1.0	9352 706 23557					
L01H.2E	EU		TDA9552H/N1/3/0607	L01HE1-1.0	9352 706 22557					
L6.1 AA	No TXT	9612		L6NOTXT-1.0		No		L6NOTXT-2.0	4822 209 13085	
L6.1 AA	No TXT	9642		L6NOTXT-2.0		Yes	Only 3 keys styling			
L6.1 AA	No TXT	9726		L6NOTXT-2.1		Yes	Option 3/4 keys styling			
L6.1 and L6.2 AA	1P TXT Mono Europe	9625	SAAS290ZP/039	L6TXIMEU-1.0				L6TXIMEU-1.1	4822 209 15954	
L6.1 and L6.2 AA	1P TXT Mono Europe		SAAS290ZP/072	L6TXIMEU-1.1		Yes	Option 3/4 keys styling	L6TXIMEU-1.1	4822 209 15954	
L6.1 and L6.2 AA	1P TXT Mono Europe	9729	SAAS290ZP/072	L6TXIMEU-1.1		Yes	Option 3/4 keys styling			
L6.1 and L6.2 AA	1P TXT Mono Europe	9840	SAAS290ZP/126	L6TXIMEU-1.2		Yes	New M5A technology			
L6.1 and L6.2 AA	1P TXT FLOF Mono Europe	9805	SAAS290ZP/093	L6M1FE-1.0		Yes	New M5A technology	L6M1FE-1.1	4822 209 16832	
L6.1 and L6.2 AA	1P TXT FLOF Mono Europe	9815	SAAS290ZP/113	L6M1FE-1.1		Yes	New M5A technology			
L6.1 and L6.2 AA	1P TXT Stereo 2CS	9642	SAAS290ZP/057	L6TXSITE-1.0		No	Only 3 keys styling			
L6.1 and L6.2 AA	1P TXT Nicam EUR	9642	SAAS290ZP/055	L6TXNIC-1.1		No	Only for 3 keys styling	L6TXNICEU-1.1	4822 209 15955	
L6.1 and L6.2 AA	1P TXT Nicam EUR	9729	SAAS290ZP/075	L6TXNICEU-1.2		No	Option 3/4 keys styling			
L6.1 and L6.2 AA	1P TXT Mono Greek/Turk	9634	SAAS290ZP/050	L6TXIMEU-1.0		Yes	Option for 3 keys styling	L6TXMGT-1.1	4822 209 15962	
L6.1 and L6.2 AA	1P TXT Mono Greek/Turk	9729	SAAS290ZP/074	L6MGT-1.1		Yes	Option for 3/4 keys styling			
L6.1 and L6.2 AA	1P TXT Nicam Greek/Turk	9720	SAAS290ZP/070	L6TXNICGT-1.1		No	Only for 3 keys styling			
L6.1 and L6.2 AA	1P TXT Nicam Greek/Turk	9729	SAAS290ZP/076	L6TXNICGT-1.2		No	Option for 3/4 keys styling			
L6.1 and L6.2 AA	1P TXT Mono Cyrillic	9722	SAAS290ZP/040	L6TXIMEU-1.0		Yes	Option for 3 key styling	L6TXMOCY-1.1	4822 209 15961	
L6.3 AA	10P TXT Europe Nicam	9819	SAAS290ZP/095	L6N1OE-1.0		No	2 scars			
L6.3 AA	10P TXT Europe Nicam	9835	SAAS290ZP/217	L6N1OE-1.1		No	ESD and searching speed Impr.			
L6.3 AA	10P TXT Europe Nicam		SAAS290ZP/219	L6N1OE-2.0		No	2 scars multi-system (OEM)			
L9.1A/L9.2A	Non-Text (English, Malay, S.)	Wk904.1 or higher	SAAS542PS/M2/017	L90AN1-1.0		No	Only suitable in combination with ST24W08CB1 (4822 209 13052)	L90AN1-1.1	9352 640 98112	
L9.1A/L9.2A	Non-Text (English, Malay, S.)	Wk927.2 or higher	SAAS542PS/M2/060	L90AN1-1.1		No	Only suitable in combination with ST24W08CB1 (4822 209 13052)	L90AN1-1.1	9352 645 12112	
L9.1A/L9.2A	Non-Text (English, Malay, S.)	Wk936.5 or higher	SAAS542PS/M4/1072	L90AN1-1.1		No	Only suitable in combination with ST24W08CB1 (4822 209 13052)	L90AN1-1.3	9353 669 24112	
L9.1A/L9.2A	Non-Text (English, Malay, S.)	Wk951.4 or higher	SAAS542PS/M4/161	L90AN1-1.3		No		N.A.	N.A.	
L9.1A/L9.2A	Non-Text (English, Arabic)	Wk928.5 or higher	SAAS542PS/M2/065	L90AN2-1.0		No	Only suitable in combination with ST24W08CB1 (4822 209 13052)	L90AN2-1.0	9352 653 69112	
L9.1A/L9.2A	Non-Text (English, Arabic)	Wk939.5 or higher	SAAS542PS/M4/1065	L90AN2-1.0		No	Only suitable in combination with ST24W08CB1 (4822 209 13052)	L90AN2-1.2	9352 673 23112	
L9.1A/L9.2A	Non-Text (English, Arabic)	Wk008.5 or higher	SAAS542PS/M4/193	L90AN2-1.2		No		N.A.	N.A.	
L9.1A/L9.2A	Non-Text (English, Thai)	Wk915.5 or higher	SAAS542PS/M2/042	L90AN3-1.0		No	Only suitable in combination with ST24W08CB1 (4822 209 13052)	L90AN3-1.1	9352 642 25112	
L9.1A/L9.2A	Non-Text (English, Thai)	Wk930.5 or higher	SAAS542PS/M2/072	L90AN3-1.1		No	Only suitable in combination with ST24W08CB1 (4822 209 13052)	L90AN3-1.1	9352 653 71112	
L9.1A/L9.2A	Non-Text (English, Thai)	Wk939.5 or higher	SAAS542PS/M4/1072	L90AN3-1.1		No	Only suitable in combination with ST24W08CB1 (4822 209 13052)	L90AN3-1.2	9352 664 04112	
L9.1A/L9.2A	Non-Text (English, Thai)	Wk944.1 or higher	SAAS542PS/M4/136	L90AN3-1.2		No	Only suitable in combination with ST24W08CB1 (4822 209 13052)	L90AN3-1.3	9352 674 90112	
L9.1A/L9.2A	Non-Text (English, Thai)	Wk011.5 or higher	SAAS542PS/M4/204	L90AN3-1.3		No		L90AN3-1.4	9352 676 20112	
L9.1A/L9.2A	Non-Text (English, Thai)	Wk015.1 or higher	SAAS542PS/M4/213	L90AN3-1.4		No		N.A.	N.A.	
L9.1A/L9.2A	Non-Text (English, Hindi)	Wk914.3 or higher	SAAS542PS/M2/040	L90AN4-1.1		No	Only suitable in combination with ST24W08CB1 (4822 209 13052)	L90AN4-1.1	9352 645 14112	
L9.1A/L9.2A	Non-Text (English, Hindi)	Wk936.5 or higher	SAAS542PS/M2/1040	L90AN4-1.1		No	Only suitable in combination with ST24W08CB1 (4822 209 13052)	L90AN4-1.2	9352 670 07112	
L9.1A/L9.2A	Non-Text (English, Hindi)	Wk952.4 or higher	SAAS542PS/M4/164	L90AN4-1.2		No		N.A.	N.A.	

Software survey

SOFTWARE SURVEY

CHASSIS	FAMILY	PRODUCTION CODE	UP TYPE/VERSION	IDENT	SERVICE CODE	HOTEL MODE ?	REMARKS TYPICAL FOR THIS SOFTWARE	REPLACED BY SERVICE CODE
L9.1A/L9.2A	Text 10 page (English, Malay, S.	Wk904.1 or higher	SAAS563P/M2/018	L90AT1-1.0	4822 209 17537	No	Only suitable in combination with ST24W08CB1 (4822 209 13052)	L90AT1-1.1
L9.1A/L9.2A	Text 10 page (English, Malay, S.	Wk929.3 or higher	SAAS563P/M2/068	L90AT1-1.1	9352 641 78112	No	Only suitable in combination with ST24W08CB1 (4822 209 13052)	9352 641 78112
L9.1A/L9.2A	Text 10 page (English, Malay, S.	Wk938.5 or higher	SAAS563P/M3/1068	L90AT1-1.1	9352 645 11112	No	Only suitable in combination with ST24W08CB1 (4822 209 13052)	9352 645 11112
L9.1A/L9.2A	Text 10 page (English, Malay, S.	Wk008.5 or higher	SAAS563P/M3/190	L90AT1-1.3	9352 673 21112	No	Only suitable in combination with ST24W08CB1 (4822 209 13052)	N.A.
L9.1A/L9.2A	Text 10 page(English, Arabic)	Wk912.5 or higher	SAAS563P/M2/037	L90AT2-1.1	9352 636 28112	No	Only suitable in combination with ST24W08CB1 (4822 209 13052)	9352 636 28112
L9.1A/L9.2A	Text 10 page(English, Arabic)	Wk919.5 or higher	SAAS563P/M2/049	L90AT2-1.1	9352 638 43112	No	Only suitable in combination with ST24W08CB1 (4822 209 13052)	9352 640 16112
L9.1A/L9.2A	Text 10 page(English, Arabic)	Wk925.1 or higher	SAAS563P/M2/058	L90AT2-1.2	9352 640 16112	No	Only suitable in combination with ST24W08CB1 (4822 209 13052)	9352 653 80112
L9.1A/L9.2A	Text 10 page(English, Arabic)	Wk938.5 or higher	SAAS563P/M3/1068	L90AT2-1.2	9352 653 80112	No	Only suitable in combination with ST24W08CB1 (4822 209 13052)	9352 673 22112
L9.1A/L9.2A	Text 10 page(English, Arabic)	Wk008.5 or higher	SAAS563P/M3/192	L90AT2-1.4	9352 673 22112	No	Only suitable in combination with ST24W08CB1 (4822 209 13052)	N.A.
L9.1A/L9.2A	NTSC - Taiwan & Philippines	Wk913.4 or higher	SAAS543P/M2/038	L90AC1-1.0	9352 636 39112	No	Only suitable in combination with ST24W08CB1 (4822 209 13052)	9352 639 94112
L9.1A/L9.2A	NTSC - Taiwan & Philippines	Wk923.5 or higher	SAAS543P/M2/054	L90AC1-1.1	9352 639 94112	No	Only suitable in combination with ST24W08CB1 (4822 209 13052)	9352 653 72112
L9.1A/L9.2A	NTSC - Taiwan & Philippines	Wk939.5 or higher	SAAS543P/M4/1054	L90AC1-1.2	9352 653 72112	No	Only suitable in combination with ST24W08CB1 (4822 209 13052)	9352 674 89112
L9.1A/L9.2A	NTSC - Taiwan & Philippines	Wk011.5 or higher	SAAS543P/M4/203	L90AC1-1.4	9352 674 89112	No	Only suitable in combination with ST24W08CB1 (4822 209 13052)	N.A.
L9.1E/L9.2E	West Europe, Mono No. Text	Wk908.5 or higher	SAAS542/M2/028	L90EM1-1.0	9352 634 45112	Yes	Only suitable in combination with ST24W08CB1 (4822 209 13052)	9352 672 50112
L9.1E/L9.2E	West Europe, Mono No. Text	Wk931.5 or higher	SAAS542/M2/075	L90EM1-1.1	9352 642 43112	Yes	Only suitable in combination with ST24W08CB1 (4822 209 13052)	9352 672 50112
L9.1E/L9.2E	West Europe, Mono No. Text	Wk938.5 or higher	SAAS542/M2/120	L90EM1-1.2	9352 653 09112	Yes	Only suitable in combination with ST24W08CB1 (4822 209 13052)	9352 672 50112
L9.1E/L9.2E	West Europe, Mono No. Text	Wk939.5 or higher	SAAS542/M4/1120	L90EM1-1.2	9352 653 21112	Yes	Only suitable in combination with ST24W08CB1 (4822 209 13052)	9352 672 50112
L9.1E/L9.2E	West Europe, Mono No. Text	Wk007.3 or higher	SAAS542/M4/186	L90EM1-1.4	9352 672 50112	Yes	When the front cinch is plugged out, the TV automatically switches to the corresponding scart.	N.A.
L9.1E/L9.2E	West Europe, Mono No. Text	Wk007.3 or higher	SAAS542/M4/186	L90EM1-1.5	9352 672 50112	Yes	When the front cinch is plugged out, the TV automatically switches to the corresponding scart.	N.A.
L9.1E/L9.2E	West Europe, Mono/Stereo 5p-xt	Wk908.5 or higher	SAAS560/M2/023	L90ET1-1.1	9352 634 40112	Yes	Only suitable in combination with ST24W08CB1 (4822 209 13052)	9352 640 13112
L9.1E/L9.2E	West Europe, Mono/Stereo 5p-xt	Wk924.3 or higher	SAAS560/M2/057	L90ET1-1.2	9352 640 13112	Yes	Only suitable in combination with ST24W08CB1 (4822 209 13052)	9352 645 57112
L9.1E/L9.2E	West Europe, Mono/Stereo 5p-xt	Wk937.1 or higher	SAAS560/M2/095	L90ET1-1.4	9352 645 57112	Yes	Only suitable in combination with ST24W08CB1 (4822 209 13052)	9352 653 77112
L9.1E/L9.2E	West Europe, Mono/Stereo 5p-xt	Wk939.5 or higher	SAAS560/M3/1035	L90ET1-1.4	9352 653 77112	Yes	Only suitable in combination with ST24W08CB1 (4822 209 13052)	9352 672 88112
L9.1E/L9.2E	West Europe, Mono/Stereo 5p-xt	Wk008.1 or higher	SAAS560/M3/188	L90ET1-1.6	9352 672 88112	Yes	Issues solved: Decoding of TV Polonia clock of the format HMM:SS (reading space instead of leading 0) before 1000 hours is supported. - Set goes into Compair mode only after video appears when AS=OFF. - When the user switches manually to AV, the statuses of Pin 8 transitions on both scart are ignored. New: - Improve NICAM reception algorithm, by auto forcing NICAM sound to mono on - Overvoltage trigger is disabled (Bimos PRD) for at least 120ms after power on. - Access to SDM during cold start by shorting Pin 1 of EEPROM ST24W08 is removed. Shorting of Pin 20 of Palmer (P0.6 for LED) during cold start will cause the software to enter SDM instead of SAM. (One can later toggle between SAM and SDM by pressing the local keys V- & P- simultaneously; this is an existing feature.) This change is to allow alternative types and sources of EEPROM to be used. (since L90ET1-1.5)	N.A.
L9.1E/L9.2E	West Europe, Mono/Stereo 10p-xt	Wk902.5 or higher	SAAS564/M2/015	L90EF1-1.2	9352 631 78112	Yes	Only suitable in combination with ST24W08CB1 (4822 209 13052)	9352 634 42112
L9.1E/L9.2E	West Europe, Mono/Stereo 10p-xt	Wk908.5 or higher	SAAS564/M2/025	L90EF1-1.3	9352 634 42112	Yes	Only suitable in combination with ST24W08CB1 (4822 209 13052)	9352 639 79112
L9.1E/L9.2E	West Europe, Mono/Stereo 10p-xt	Wk923.2 or higher	SAAS564/M2/052	L90EF1-1.5	9352 639 79112	Yes	Only suitable in combination with ST24W08CB1 (4822 209 13052)	9352 645 56112
L9.1E/L9.2E	West Europe, Mono/Stereo 10p-xt	Wk934.5 or higher	SAAS564/M2/094	L90EF1-1.7	9352 645 56112	Yes	Only suitable in combination with ST24W08CB1 (4822 209 13052)	9352 653 78112
L9.1E/L9.2E	West Europe, Mono/Stereo 10p-xt	Wk939.5 or higher	SAAS564/M3/1094	L90EF1-1.7	9352 653 78112	Yes	Only suitable in combination with ST24W08CB1 (4822 209 13052)	9965 000 05400
L9.1E/L9.2E	West Europe, Mono/Stereo 10p-xt	Wk948.4 or higher	SAAS564/M3/1094	L90 EU31 6.21	9965 000 05400	Yes	Only suitable in combination with ST24W08CB1 (4822 209 13052)	9965 000 05400
L9.1E/L9.2E	West Europe, Mono/Stereo 10p-xt	Wk006.5 or higher	SAAS564/M3/181	L90EF1-1.9	9352 672 22112	Yes	see remarks L90ET1-1.6	N.A.
L9.1E/L9.2E	East Europe, Mono No. Text	Wk908.5 or higher	SAAS542/M2/027	L90EM2-1.0	9352 634 44112	Yes	Only suitable in combination with ST24W08CB1 (4822 209 13052)	9352 642 42112
L9.1E/L9.2E	East Europe, Mono No. Text	Wk931.5 or higher	SAAS542/M2/074	L90EM2-1.1	9352 642 42112	Yes	Only suitable in combination with ST24W08CB1 (4822 209 13052)	9352 653 88112
L9.1E/L9.2E	East Europe, Mono No. Text	Wk939.5 or higher	SAAS542/M4/1074	L90EM2-1.1	9352 653 88112	Yes	Only suitable in combination with ST24W08CB1 (4822 209 13052)	9352 672 49112
L9.1E/L9.2E	East Europe, Mono No. Text	Wk007.3 or higher	SAAS542/M4/185	L90EM2-1.3	9352 672 49112	Yes	Only suitable in combination with ST24W08CB1 (4822 209 13052)	9352 672 49112
L9.1E/L9.2E	East Europe, Mono No. Text	Wk007.3 or higher	SAAS542/M4/185	L90EM2-1.4	9352 672 49112	Yes	see remarks L90EM1-1.5	N.A.
L9.1E/L9.2E	East Europe, Mono/Stereo 5p-xt	Wk908.5 or higher	SAAS560/M2/024	L90ET2-1.0	9352 634 41112	Yes	Only suitable in combination with ST24W08CB1 (4822 209 13052)	9352 639 96112
L9.1E/L9.2E	East Europe, Mono/Stereo 5p-xt	Wk923.5 or higher	SAAS560/M2/056	L90ET2-1.2	9352 639 96112	Yes	Only suitable in combination with ST24W08CB1 (4822 209 13052)	9352 653 79112
L9.1E/L9.2E	East Europe, Mono/Stereo 5p-xt	Wk939.5 or higher	SAAS560/M3/1056	L90ET2-1.2	9352 653 79112	Yes	Only suitable in combination with ST24W08CB1 (4822 209 13052)	9352 672 87112

Software survey

SOFTWARE SURVEY									
CHASSIS	FAMILY	PRODUCTION CODE	UP TYPE/VERSION	IDENT	SERVICE CODE	HOTEL MODE ?	REMARKS TYPICAL FOR THIS SOFTWARE	IDENT	REPLACED BY SERVICE CODE
L9.1E / L9.2E	East Europe, Mono/Stereo 5p-xt	WK008.1 or higher	SAA5560/M3/187	L90EF2-1.4	9352 672 87112	Yes	Issues solved :- Set IIT DC NOTCH register to ON always. - Status of Scart2 is not read when option 2X-OFF. This eliminates the need to ground. - When the user press the up/down arrow key (and provided that the 16/94:3 feature is available), monitoring the voltage level on scart pin 8 for change in aspect ratio is stopped. - Keep AFC window large for N2 Bimos TDA884x when not in auto/manual search. - Set goes into Compare mode only after video appears when AS-OFF. - When the user switches manually to AV, the statuses of Pin 8 transitions on both scart are ignored. New: - Improve NICAM reception algorithm, by auto forcing NICAM sound to mono on. - Disable overvoltage trigger (Bimos PRD) for at least 120ms after power on. - Access to SDM during cold start by shorting Pin 1 of EEPROM ST24W0x is removed.	N.A.	N.A.
L9.1E / L9.2E	East Europe, Mono/Stereo 10p-xt	WK902.5 or higher	SAA5564/M2/016	L90EF2-1.0	4822 209 17488	Yes	Only suitable in combination with ST24W08CB1 (4822 209 13052)	L90EF2-1.1	9352 634 43112
L9.1E / L9.2E	East Europe, Mono/Stereo 10p-xt	WK906.5 or higher	SAA5564/M2/026	L90EF2-1.1	9352 634 43112	Yes	Only suitable in combination with ST24W08CB1 (4822 209 13052)	L90EF2-1.3	9352 639 95112
L9.1E / L9.2E	East Europe, Mono/Stereo 10p-xt	WK923.5 or higher	SAA5564/M2/055	L90EF2-1.3	9352 639 95112	Yes	Only suitable in combination with ST24W08CB1 (4822 209 13052)	L90EF2-1.3	9352 645 10112
L9.1E / L9.2E	East Europe, Mono/Stereo 10p-xt	WK936.5 or higher	SAA5564/M3/1035	L90EF2-1.3	9352 645 10112	Yes	Only suitable in combination with ST24W08CB1 (4822 209 13052)	L90EF2-1.5	9352 672 23112
L9.1E / L9.2E	East Europe, Mono/Stereo 10p-xt	WK006.5 or higher	SAA5564/M3/182	L90EF2-1.5	9352 672 23112	Yes	See remarks L90ET2-1.4	N.A.	N.A.
L9.1L / L9.2L		WK906.3 or higher	SAA5543P/M2/019	L90LS1-1.0	4822 209 17542		CC Mono/Stereo (English, Portuguese, Spanish)	L90LS1-1.1	9352 642 82112
L9.1L / L9.2L		WK931.1 or higher	SAA5543P/M2/073	L90LS1-1.0	9352 642 37112		CC Mono/Stereo (English, Portuguese, Spanish)	L90LS1-1.2	9352 653 75112
L9.1L / L9.2L		WK939.5 or higher	SAA5543P/M4/1073	L90LS1-1.2	9352 653 75112		CC Mono/Stereo (English, Portuguese, Spanish)	L90LS1-1.3	9352 672 35112
L9.1L / L9.2L		WK007.3 or higher	SAA5543P/M4/183	L90LS1-1.3	9352 672 35112		CC Mono/Stereo (English, Portuguese, Spanish)	N.A.	N.A.
L9.1L / L9.2L		WK007.3 or higher	SAA5543P/M4/183	L90LS1-1.4	9352 672 35112		CC Mono/Stereo (English, Portuguese, Spanish)	N.A.	N.A.
L9.3	14PT3685/01/01E/05/58	WK109.5 or higher	SAA5565P/M3/0244	NV1 EU V1.2	9352 679 28112	No		n.a.	n.a.
L9H.1A/L9H.2A	version PAL (New Zealand only)		SAA5533P/M4	version 1.6	9965 000 10922		OTP		
L9H.1A/L9H.2A	R, Y and Z versions PAL		SAA5533P/M4	163 (version 2.5)	9352 669 51112		OTP	version 2.6	9965 000 05974
L9H.1A/L9H.2A	R, Y and Z versions PAL		SAA5533P/M4	version 2.6	9965 000 05974		OTP		
L9H.1E AA	System	week 0016 or higher	SAA5560P/M3	L9HES-1.2	3119 100 50841	Yes	OTP	L9HES-1.5	9965 000 10620
L9H.1E AA	System	week 0016 or higher	SAA5560P/M3	L9HES-1.3	3119 100 50871	Yes	OTP	L9HES-1.5	9965 000 10620
L9H.1E AA	System	week 0040 or higher	SAA5560P/M3	L9HES-1.5	9965 000 10620	Yes	OTP Canal + adaptation		
L9H.2E AA	System	week 0016 or higher	SAA5560P/M3	L9HES-1.2	3119 100 50841	Yes	OTP	L9HES-1.5	9965 000 10620
L9H.2E AA	System	week 0016 or higher	SAA5560P/M3	L9HES-1.3	3119 100 50871	Yes	OTP	L9HES-1.5	9965 000 10620
L9H.2E AA	System	week 0040 or higher	SAA5560P/M3	L9HES-1.5	9965 000 10620	Yes	OTP Canal + adaptation		
L9H.2E AA	Basic (no xt)	week 0016 or higher	SAA5543P/M4	L9HEB-1.2	3119 100 50851	Yes	OTP	L9HEB-1.8	9965 000 08008
L9H.2E AA	Basic (no xt)	week 0040 or higher	SAA5543P/M4	L9HEB-1.4	3119 100 50901	Yes	OTP	L9HEB-1.8	9965 000 08008
L9H.2E AA	Basic (no xt)	week 0108 or higher	SAA5543P/M4	L9HEB-1.5	3119 100 50981	Yes	OTP Canal + adaptation		
L9H.2E AA	Basic (no xt)	week 0108 or higher	SAA5543P/M4	L9HEB-1.6	3119 100 51071	Yes	OTP Several modifications		
L9H.2E AA	Basic (no xt)	week 0145 or higher	SAA5543P/M4	L9HEB-1.8	9965 000 08008	Yes	OTP Scart pin 8 active in commercial mode		
L9H.2E AA	Basic + (xt,clock,radio)	week 0016 or higher	SAA5563P/M3	L9HEP-1.2	3119 100 50861	Yes	OTP	L9HEP-1.8	9965 000 08070
L9H.2E AA	Basic + (xt,clock,radio)	week 0016 or higher	SAA5563P/M3	L9HEP-1.4.1	3119 100 50911	Yes	OTP	L9HEP-1.8	9965 000 08070
L9H.2E AA	Basic + (xt,clock,radio)	week 0040 or higher	SAA5533P/M4	L9HEP-1.5	3119 100 50991	Yes	OTP Canal + adaptation		
L9H.2E AA	Basic + (xt,clock,radio)	week 0108 or higher	SAA5533P/M4	L9HEP-1.6	3119 100 51081	Yes	OTP Several modifications		
L9H.2E AA	Basic + (xt,clock,radio)	week 0145 or higher	SAA5533P/M4	L9HEP-1.8	9965 000 08070	Yes	OTP Scart pin 8 active in commercial mode		
L9H.2E AA	On-Card	week 0016 or higher	SAA5560P/M3	L9HES-1.2	3119 100 50841	Yes	OTP	L9HES-1.5	9965 000 10620
L9H.2E AA	On-Card	week 0016 or higher	SAA5560P/M3	L9HES-1.3	3119 100 50871	Yes	OTP	L9HES-1.5	9965 000 10620
L9H.2E AA	On-Card	week 0040 or higher	SAA5560P/M3	L9HES-1.5	9965 000 10620	Yes	OTP Canal + adaptation		
MG1.1E	CL4	Start production		MG11E11.0_02101	3104 317 42101	No	Solved: Operation hours not correct, NVM : Prevent writing of Vslope = 0. System	MG11E11.1_02201	3104 317 42201
MG1.1E	CL4	Week 9950 and higher		MG11E11.1_02201	3104 317 42201	No	French changes to West Europe after search, change noise reduction parameters for auto TV. Nr of favourites can be 100, i.s.o. 99		
MG1.1E	CL4			MG11E11.2_02271	3104 317 42271	No	Solved: Fixed AFC value is used when SECAM L is detected, right status detection with VCR. EPG works properly with Nextview 1.3, new volume table for Europe EDRIC-s&s		
MG2.1E		Start production		MG21E11.0_01471	-	No		MG21E11.0_01501	4822 900 11275

Software survey

SOFTWARE SURVEY									
CHASSIS	FAMILY	PRODUCTION CODE	UP TYPE/VERSION	IDENT	SERVICE CODE	HOTEL MODE ?	REMARKS TYPICAL FOR THIS SOFTWARE	IDENT	REPLACED BY SERVICE CODE
MG2.1E		Week 9839 and higher		MG21E11.0_01501	-	No	M6 problem solved, paneltest problem solved, secam correction with VCR introduced, service stepwise control, seconds problem in clock extraction solved	MG21E11.0_01561	4822 900 11275
MG2.1E	CL1	Week 9844 and higher		MG21E11.0_01561	-	No	See table 4	MG21E11.3_01611	4822 900 11275
MG2.1E	CL1	Week 9851 and higher		MG21E11.3_01611	-	No	See table 5	MG21E11.5_01861	4822 900 11275
MG2.1E	CL1	Week 9915 and higher		MG21E11.5_01861	-	No	Stereo detection problem and blocking of teletext on some transmitters solved	MG21E11.7_01941	4822 900 11275
MG2.1E	CL1	Week 9915 and higher		MG21E11.7_01941	-	No		MG21E11.8_02191	4822 900 11275
MG2.1E	CL1	Week 9950 and higher, only for service		MG21E11.8_02191	-	No	Half TXT pages on ITV, Operation hours not correct, problem with Belgian subtitles, CNI code of ZDF not recognised, NVM - Prevent writing of Vslope = 0 and suddenly switching preset is solved	MG21E11.9_02401	4822 900 11275
MG2.1E	CL1	Week 0018 and higher, only for service		MG21E11.9_02401	4822 900 11275	No		-	-
MG2.1E	CL1 China (29DST00/93)	Start production		MG21A11.0_01571	-	No		MG21A11.6_01901	4822 900 11324
MG2.1E	CL1 China (29DST00/93)	Week 9915 and higher		MG21A11.6_01901	4822 900 11324	No		-	-
MG2.1E	CL2A	Start production		MG21E11.0_01591	-	No		MG21E12.2_01851	4822 900 11326
MG2.1E	CL2A	Week 9913 and higher		MG21E12.0_01821	-	No		MG21E12.2_01851	4822 900 11326
MG2.1E	CL2A	Week 9914 and higher		MG21E12.2_01851	-	No		MG21E12.3_01931	4822 900 11326
MG2.1E	CL2A	Week 9915 and higher		MG21E12.2_01871	-	No		MG21E12.4_01961	4822 900 11326
MG2.1E	CL2A	Week 9920 and higher		MG21E12.3_01931	-	No	Solution for loud volume at startup, noise (together with FBX 01911, TXT acquisition, stereo detection)	-	-
MG2.1E	CL2A	Week 9922 and higher		MG21E12.4_01961	-	No	Solved: blocking of teletext on some transmitters	MG21E12.5_02181	4822 900 11326
MG2.1E	CL2A	Week 9950 and higher, only for service		MG21E12.5_02181	-	No	Half TXT pages on ITV, Operation hours not correct, problem with Belgian subtitles, CNI code of ZDF not recognised, NVM - Prevent writing of Vslope = 0 and Suddenly switching preset is solved	MG21E12.6_02411	4822 900 11326
MG2.1E	CL2A	Week 0018 and higher, only for service		MG21E12.6_02411	4822 900 11326	No		-	-
MG2.1E	FBX CL1+2A	Start production		R3_5V1B (01751)	-	No		R3_6V1B (01791)	4822 900 11276
MG2.1E	FBX CL1+2A	Week 9912 and higher		R3_6V1B (01791)	-	No		R3_6V1B (01831)	4822 900 11276
MG2.1E	FBX CL1+2A	Week 9914 and higher		R3_8V1B (01831)	-	No		R3_10V1B (01881)	4822 900 11276
MG2.1E	FBX CL1+2A	Week 9915 and higher		R3_10V1B (01881)	-	No	Horizontal shift problem solved	R3_12V1B (01911)	4822 900 11276
MG2.1E	FBX CL1+2A	Week 9920 and higher		R3_12V1B (01911)	4822 900 11327	No	Can only be used with SAA4978HV1 or SAA4978HV102	R3_15V2A (02131)	3104 317 42131
MG2.1E	FBX CL1+2A	Week 99 and higher		R3_15V2A (02131)	3104 317 42131	No		-	-
MG2.1E	CL1+2A	AG/QG10 and higher		MG21E13.0_01991	3104 317 41991	No	Production start	MG21E13.1_02091	3104 317 02091
MG2.1E	CL1+2A	AG/QG10 and higher, week 9944 and higher		MG21E13.1_02091	3104 317 02091	No	HOP N2C compatible, EPF-G improvement, Mute on headphone with blue mute when starting up on noise, no automatic subpage is solved, no subtitle when going out of TXT is solved	MG21E13.2_02171	3104 317 42171
MG2.1E	CL1+2A	AG/QG10 and higher, week 0010 and higher		MG21E13.2_02171	3104 317 42171	No	Prevent writing of V-slope=0, operating hours are correct after 128 hours, fixed AFC value is used when SECAM L is detected, right status detection with VCR, EPF works properly with Nextview 1.3, new volume table for Europe EDRIC-sets	MG21E13.3_02311	3104 317 42311
MG2.1E	CL1+2A	AG/QG11 and higher, week 0020 and higher		MG21E13.3_02311	3104 317 42311	No	Option codes change due to Acoustic system (cabinets), Solutions for: small black bars in TXT, for EPF 2C3, freeze overruled after blackbar detection, hangups in level 2.5 TXT	MG21E13.5_02591	3104 317 42591
MG2.1E	CL1+2A	Not used in production		MG21E13.4_02321	3104 317 42321	No	Not used in production	MG21E13.5_02591	3104 317 42591
MG2.1E	CL1+2A	AG/QG11 and higher, week 0041 and higher		MG21E13.5_02591	3104 317 42591	No	Solved: 3SA i.s.o. 3SAT in EPF screen, timer problem New Zealand, change of take-over point between MSP and EDRIC from +11 to 0dB, centration of TXT, IF AFC adjustment for SECAM L, service entry with normal remote possible, subtitle offset on/off possible at auto format	-	-
MG2.1E	FBX CL1+2A	FBX: AG/QG10 and higher		R3_13V2A (01920)	3104 317 41921	No		R3_15V2A (02130)	3104 317 42131
MG2.1E	FBX CL1+2A	FBX: AG/QG10 and higher		R3_15V2A (02130)	3104 317 42131	No	SECAM notch active in FBX at SECAM	T3_17V2A	9985 000 06621
MG2.1E	FBX CL1+2A			T3_17V2A	9985 000 06621	No	Solution for picture instability with digital decoders and DVD	-	-
MG3.1A	CL5B	Start production		MG31A11.0_02061	3104 317 42061	No	Not used in production	MG31E11.1_02111	3104 317 42111
MG3.1A	CL5B	Week 9941 and higher		MG31A11.1_02111	3104 317 42111	No	Used in production for: -/57/69/93	MG31E11.2_02121	3104 317 42121
MG3.1A	CL5B	Week 9943 and higher		MG31A11.2_02121	3104 317 42121	No	TXT problem solved, can be used in all sets	MG31E11.3_02151	3104 317 42151

SOFTWARE SURVEY									
CHASSIS	FAMILY	PRODUCTION CODE	UP TYPE/VERSION	IDENT	SERVICE CODE	HOTEL MODE ?	REMARKS TYPICAL FOR THIS SOFTWARE	IDENT	REPLACED BY SERVICE CODE
MG3.1A	CL5B	Week 0001 and higher		MG31A11.3_02151	3104-317-42151	No	Flashing when LNA switched off is solved, power picture can be stored, translations corrected, plops are solved, change mute behaviour rear AV's, prevent writing of V-slope = 0.	MG31A11.4_02251	3104-317-42251
MG3.1A	CL5B	Week 0014 and higher		MG31A11.4_02251	3104-317-42251	No	Solved: Give name list distorted (reshuffle), power picture is YES and should be NO, OSD 'sound muted' when volume minimum, Nr of favourites can be 100 i.s.o. 99.	MG31A11.5_02261	3104-317-42261
MG3.1A	CL5B	Week 0023 and higher		MG31A11.5_02261	3104-317-42261	No	Solved: No dual I/II possible with DK, AFC and AGC of PIP can't be stored, power picture changes to YES, add subtitle offset on/off at auto format, introduction of frame rotation, TXT software error when default object not found	MG31A11.7_02861	3104-317-42861
MG3.1A	CL5B	Week 0052 and higher		MG31A11.6_02761	3104-317-42761	No	Solved: no check for AGI during 2nd band search, Auto installation; correct the TV-system during the second pass, rotation coil can be selected when 4:3 tube is selected, no horizontal disturbance in the right screen of VDS, no progressive scan if option on 1050/1250!	MG31A11.7_02861	3104-317-42861
MG3.1A	CL5B	Week 0105 and higher		MG31A11.7_02861	3104-317-42861	No	Solved: 1250i mode resets autoframat, 1250i scanning mode added, no 1050i selectable if PIP is on, 1250i mode if left when TXT is left, no menu available if subtitle is on, store vertical shift as last status	MG31A11.8_02981	3104-317-42981
MG3.1A	CL5B	Week 0124 and higher		MG31A11.8_02981	3104-317-42981	No	Solved: unstable PIP picture with POPOV N2, some lines of FLOF are not blanked in TXT level 2.5	-	-
MG3.1E/A/U/MG4.1	FBX: CL2B	Start production		R4_1 (01970)	3104-317-41971	No		R4_2 (02000)	3104-317-42001
MG3.1E/A/U/MG4.1	FBX	Week 9927 and higher		R4_2 (02000)	3104-317-42001	No	Solved: problem with stable OSD and 60Hz, still picture jitters when freeze is on.	R4_3 (02010)	3104-317-42011
MG3.1E/A/U/MG4.1	FBX	Week 9929 and higher		R4_3 (02010)	3104-317-02011	No		R4_5 (02070)	3104-317-42071
MG3.1E/A/U/MG4.1	FBX France	Only France: WK 9938 and higher		R4_4 (02050)	3104-317-42051	No	Solved: autoframat does not always see the lowest black bar, SECAM cross-colour triggers the FILM mode when even only a VIDEO signal is applied	R4_6 (02240)	3104-317-42241
MG3.1E/A/U/MG4.1	FBX	Week 9940 and higher		R4_5 (02070)	3104-317-42071	No	Solved: vertical jitter after swap Double Window, stable OSD in progressive scan.	R4_6 (02240)	3104-317-42241
MG3.1E/A/U/MG4.1	FBX	Week 0006 and higher		R4_6 (02240)	3104-317-42241	No	Solved: during irregular phrases stripes are visible, jump of several lines between FILM 32 and UNKNOWN mode	R4_7 (02350)	3104-317-42351
MG3.1E/A/U/MG4.1	FBX	Week 0016 and higher		R4_7 (02350)	3104-317-42351	No	Solved: problems with playstation, non-interaced input gives a jump in the picture when going into FILM-mode	R4_8 (02420)	3104-317-42421
MG3.1E/A/U/MG4.1	FBX	Week 0018 and higher		R4_8 (02420)	3104-317-42421	No	Solved: CTI shows sometimes jitter in DW application, AR busy hangup during Not used in production	R4_10 (02681)	3104-317-42681
MG3.1E/A/U/MG4.1	FBX	Week 0042 and higher		R4_10 (02681)	3104-317-42681	No		R4_11 (02831)	3104-317-42831
MG3.1E/A/U/MG4.1	FBX	Week 0104 and higher		R4_11 (02831)	3104-317-42831	No	Solved: 1050i mode resets autoframat	R4_12 (02901)	3104-317-42901
MG3.1E/A/U/MG4.1	FBX	Week 0110 and higher		R4_12 (02901)	3104-317-42901	No		R4_13 (03091)	3104-317-43091
MG3.1E/A/U/MG4.1	FBX	Week 0126 and higher		R4_13 (03091)	3104-317-43091	No	Solved: set goes in protection during ACI, quiet is not always detected on DVD still pictures, it takes too long before quiet mode is activated in progressive scan	-	-
MG3.1E/MG7.1E	CL2B/CL6	Start production		MG31E11.0_01981	3104-317-41981	No		MG31E11.1_02031	3104-317-02031
MG3.1E/MG7.1E	CL2B/CL6	Week 9935 and higher		MG31E11.1_02031	3104-317-02031	No	HOP NZC compatible, Contrast adjusted with active control, active control has now: off, min, med, max, Austria is selectable in the 'country' menu, PIP solution	MG31E11.3_02081	3104-317-42081
MG3.1E/MG7.1E	CL2B France	Only France: Week 9938 and higher		MG31E11.2_02041	3104-317-42041	No	Secam Notch-interface to FBX only in -/19 and -/56, only used in 4:3 sets.	MG31E11.5_02161	3104-317-42161
MG3.1E/MG7.1E	CL2B/CL6	Week 9935 and higher		MG31E11.3_02081	3104-317-42081	No	Only used in non RF 16/9 sets. When used in 4:3 sets the PIP picture with PAL I signal will be grey	MG31E11.5_02161	3104-317-42161
MG3.1E/MG7.1E	CL2B/CL6	Week 9946 and higher		MG31E11.4_02141	3104-317-42141	No	Used in 32" and 36" RF sets. Shift of TXT in 36" is solved	MG31E11.5_02161	3104-317-42161
MG3.1E/MG7.1E	CL2B/CL6	AG/OG01 and higher, week 0008 for xPW9765 and week 0011 and higher for all other sets		MG31E11.5_02161	3104-317-42161	No	FBX on fast I2C bus, compatibility with Nextview 1.3, operation hours are correct, prevent overwriting of V-slope with 0, volume table for EDRIC sets has changed, fixed AFC value is used when secam L is detected, ComPair not working with this release.	MG31E11.6_02291	3104-317-42291
MG3.1E/MG7.1E	CL2B/CL6	AG/OG02 and higher, week 0020 and higher		MG31E11.6_02291	3104-317-42291	No	Option codes change due to Acoustic system (cabinets). Solutions for: small black bars in TXT, for EPG 2C3, Freeze overruled after blackbar detection, hangups in level 2.5 TXT, wrong status detection with VR969 and VR960, AFC and AGC of PIP and FDS can be stored via service menu (temporary 2 points must be connected) and ComPair tool works again.	MG31E11.8_02581	3104-317-42581
MG3.1E/MG7.1E	CL2B/CL6	Not used in production		MG31E11.7_02301	3104-317-42301	No	Not used in production.	MG31E11.8_02581	3104-317-42581
MG3.1E/MG7.1E	CL2B/CL6	AG/OG02 and higher, week 0041 and higher		MG31E11.8_02581	3104-317-42581	No	Solved: 35A i.s.o. 3SAT in EPG screen, timer problem New Zealand, change of take-over point between MSP and EDRIC from +11 to 0dB, centration of TXT, IF AFC adjustment for SECAM L, service entry with normal remote possible, subtitle offset on/off possible at auto format	MG31E11.9_02811	3104-317-42811
MG3.1E/MG7.1E	CL2B/CL6	Not used in production		MG31E11.9_02811	3104-317-42811	No	Only released for service, introduction picture tilt function for 4:3 sets	MG31E11.A_02851	3104-317-42851

Software survey

SOFTWARE SURVEY									
CHASSIS	FAMILY	PRODUCTION CODE	UP TYPE/VERSION	IDENT	SERVICE CODE	HOTEL MODE ?	REMARKS TYPICAL FOR THIS SOFTWARE	IDENT	REPLACED BY SERVICE CODE
MG3.1E/MG7.1E	CL2B/CL6			MG31E11.A_02851	3104 317 42851	No	Introduction for /xxM sets, change value anti-moire parameters in PAL and Secam, selection of rotation coil is not possible when 4:3 tube is selected	-	-
MG3.1U	CL8	Start production		MG31U11.0_02361	3104 317 42361	No		MG31U11.0_02461	3104 317 42461
MG3.1U	CL8	Week 0036 and higher		MG31U11.1_02461	3104 317 42461	No	Solved: protection when toggling between AV4 and a NTSC source, bad P-r-P-behaviour	MG31U11.4_02541	3104 317 42541
MG3.1U	CL8	Not used in production		MG31U11.2_02501		No	Not used in production	MG31U11.4_02541	3104 317 42541
MG3.1U	CL8	Not used in production		MG31U11.3_02511		No	When using Y/C input and status detection the viewmode is either 4:3 or widescreen, autoprogramming interrupted by demobanner of gemstar, disable pop up of virgin mode when the channelmap is empty, double height of OSD/Menu on AV4 when natural motion is OFF, G+ is switching off the colour enhancement, bad CC decoding	MG31U11.5_02551	3104 317 42551
MG3.1U	CL8	Week 0036 and higher		MG31U11.4_02541	3104 317 42541	No			
MG3.1U	CL8	Week 0111 and higher		MG31U11.5_02551	3104 317 42551	No	Set does not startup with blank NVM, surf key disabled when auto programming is in progress, cursor repositioning in zoom when freezed, right speaker icon not correct, natural motion display remains active after AV4 is selected with natural motion ON, bad view mode information in UI for AV4, panning disabled when picture frozen while zoom is on, change takeover point between MSP and Edric, no picture and no CC after startup, optimize pip3/pip8 settings, in CC text mode first character is missing, status info is not updated properly for alt audio, wide border around replay window when coming from 4:3 DW setting		
MG3.1U	CL8					No			
MG3.1U	CL8			MG31U12.4_03021	3104 317 43021	No		MG31U12.5_03051	3104 317 43051
MG3.1U	CL8			MG31U12.5_03051	3104 317 43051	No			
MG3.1U	CL8			MG31U12.6_03081	3104 317 43081	No			
MG3.1U	CL8			MG31U12.7_03421	3104 317 43421	No			
MG3.2E		Start production		MG32E11.0_03341	3104 317 43341	No		MG32E11.1_03541	3104 317 43541
MG3.2E		Week 0151 and higher		MG32E11.1_03541	3104 317 43541	No			
MG3.2E	FBX	Start production		RE1F2_04	3104 317 43531	No			
MG4.1E		Start production		MG41E11.0_02661	3104 317 42661	No		MG41E11.1_03031	3104 317 43031
MG4.1E		Week 0114 and higher		MG41E11.1_03031	3104 317 43031	No		MG41E11.2_03071	3104 317 43071
MG4.1E		Week 0121 and higher		MG41E11.2_03071	3104 317 43071	No	Sound settings adapted for 32"	MG41E11.3_03181	3104 317 43181
MG4.1E		Week 0131 and higher		MG41E11.3_03181	3104 317 43181	No	Set always starts up in Multimedia in digital		
MG5.1E	CL2A	Start production			3135 015 11541	No			
MG5.1E	CL2A	TD01 and higher		MG51E13.3_02071	3135 015 22061	No			

Model number survey

MODEL	STYLING	CHASSIS	RC	SYSTEM	IMAGE	SOUND	SIZE	VOLTRANGE	TUNER	OPTION CODES	7	8
				P...=PAL S...=SECAM N...=NTSC	Mono N...=NICAM F...=FM/FM	wxhxd (cm)				1 2 3	4 5 6	
14PT1356/01	365	L01.2E	RCLE012	P-BGDKI,S-BGDKLL		MONO	38x38x38	220-240V	UV1317/A I G-3	See sticker in set		
14PT1356/05	365	L01.2E	RCLE012	P-BGI		MONO	38x38x38	220-240V	UV1317/A I G-3	See sticker in set		
14PT1356/06	365	L01.2E	RCLE011	P-BGDK,S-BGDKLL		MONO	38x38x38	220-240V	UV1317/A I G-3	See sticker in set		
14PT1556/05	365	L01.2E	RCLE011	P-BGI		MONO	38x38x38	220-240V	UV1317/A I G-3	See sticker in set		
14PT1556/58	365	L01.2E	RCLE011	P-BGDK,S-BGDK		MONO	38x38x38	220-240V	UV1317/A I G-3	See sticker in set		
14PT2001/59B	370	L01.2A	RC19335003/01	P-BGDK,S-BGDKK1		MONO	44x44x45	150-276V	TEDE9-228B	16 215 65	0 194	9
14PT2001/59C	370	L01.2A	RC19335003/01	P-BGDK,S-BGDKK1		MONO	44x44x45	150-276V	TEDE9-228B	16 215 65	0 194	9
14PT2002/01	308	L01.2E	RCLE011_S	P-BGDKI,S-BGDKLL		MONO	38x35x37	220-240V	URI1316R/A 1-3	See sticker in set		
14PT2002/05	308	L01.2E	RCLE011_S	P-BGI		MONO	38x35x37	220-240V	URI1316R/A 1-3	See sticker in set		
14PT2002/58	308	L01.2E	RCLE011_S	P-BGDK,S-BGDKK1	N-4,43(6.5)	MONO	38x35x37	220-240V	URI1316R/A 1-3	See sticker in set		
14PT2012/59B	371	L01.2A	RC19042001/01	P-BGDK,S-BGDKK1	N-4,43(6.5)	MONO	52x43x45	90-276V	TEDE9-228B	16 247 65	0 210	9
14PT2012/59C	371	L01.2A	RC19042001/01	P-BGDK,S-BGDKK1	N-4,43(6.5)	MONO	52x43x45	90-276V	TEDE9-228B	16 247 65	0 210	9
14RFL150/37R	321	L01.2U	RC19036002/01	N-M	B-DBX	B-DBX	56x48x51	90-140V	ENV56D9863	0 23 1 162 180 152 0	0 194	0
14RFL150/85R	321	L01.2U	RC19036002/01	N-M	B-DBX	B-DBX	56x48x51	90-140V	ENV56D9863	0 23 1 162 180 152 0	0 194	0
15PT9925/12S	334	F21RE										
15PT2301/71R	321	L01.2A	RC19335003/01	P-BGDKI,S-BGDK	N-M/4,43(5.5)/4,43(6.5)	N-BGDK,2SC-BGDK,AV S	44x10x33	95-264V	TEDEH9-200A	160 215 65	162 246	144
17PT1666/01	349	L01.2E	RCLE011	P-BGDKI,S-BGDKLL		MONO	42x38x40	220-240V	TEDEH9-004A	See sticker in set		
17PT1666/05	349	L01.2E	RCLE011	P-BGI		MONO	42x38x40	220-240V	TEDEH9-004A	See sticker in set		
20PT1346/01	359	L01.2E	RCLE012	P-BGDKI,S-BGDKLL		MONO	52x50x49	220-240V	TEDE9-004A	See sticker in set		
20PT1346/58	359	L01.2E	RCLE012	P-BGDK,S-BGDK		MONO	52x50x49	220-240V	TEDE9-004A	See sticker in set		
20PT1546/01	359	L01.2E	RCLE011	P-BGDKI,S-BGDKLL		MONO	52x50x49	220-240V	TEDE9-004A	See sticker in set		
20PT1546/58	359	L01.2E	RCLE011	P-BGDK,S-BGDK		MONO	52x50x49	220-240V	TEDE9-004A	See sticker in set		
20PT1500/59A	373	L01.2A	RC19335003/01	P-BGDK,S-BGDKK1	N-4,43(6.5)	MONO	52x50x49	220-240V	TEDE9-004A	See sticker in set		
20RFL160/37R	377	L01.2U	RC19036002/01	N-M	B-DBX	B-DBX	72x62x61	90-140V	ENV56D9863	0 215 129	162 252	152 0
20RFL160/85R	377	L01.2U	RC19036002/01	N-M	B-DBX	B-DBX	72x62x61	90-140V	ENV56D9863	0 215 129	162 252	152 0
21HT2001/59Z	376	L01H.2A	RC19042001/01	P-BGDK,S-BGDKK1	N-3,58(6.5)/3,58(6.5)/4,43	MONO	61x57x59	90-276V	TEDE9-228B	8 0 2 2	2 113 0	0
21HT2001/79Z	376	L01H.2A	RC19042001/01	P-BGDK,S-BGDKK1	N-3,58(6.5)/3,58(6.5)/4,43	MONO	61x57x59	90-276V	TEDE9-228B	8 0 2 2	2 113 0	0
21HT2002/79R	376	L01H.2A	RC2882/01	P-BGDKI,S-BGDKLL		MONO	61x57x59	90-276V	TEDE9-228B	8 4 2 9	2 113 0	0
21HT2017/69Y	375	L01H.2A	RC2882/01	P-BGDKI,S-BGDKK1	N-3,58(6.5)/3,58(6.5)/4,43(6.5)	N-DKBGDIID,2SC-BGDK,AV S	68x58x57	90-276V	TEDE9-228B	9 21 2 9	22 113 0	0
21HT2017/79Y	375	L01H.2A	RC2882/01	P-BGDKI,S-BGDKK1	N-3,58(6.5)/3,58(6.5)/4,43(6.5)	N-DKBGDIID,2SC-BGDK,AV S	68x58x57	90-276V	TEDE9-228B	9 21 2 9	22 113 0	0
21HT2121/68Z	374	L01H.1A	RC19042001/01	P-BGDKI,S-BGDKK1	N-3,58(6.5)/3,58(6.5)/4,43	N-DKBGDIID,2SC-BGDK,AV S	72x62x61	90-276V	TEDE9-228B	9 16 34 2	14 113 0	0
21HT2212/67R	374	L01H.1A	RC2882/01	P-BGDKI,S-BGDKK1	N-3,58(6.5)/3,58(6.5)/4,43(6.5)	N-DKBGDIID,2SC-BGDK,AV S	72x62x61	90-276V	TEDE9-228B	11 4 34	9 10	113 0
21PT1346/58	362	L01.2E	RCLE012	P-BGDK,S-BGDK		MONO	52x50x49	220-240V	TEDE9-004A	See sticker in set		
21PT1356/58	367	L01.2E	RCLE012	P-BGDKI,S-BGDKLL		MONO	52x47x48	220-240V	TEDE9-004A	See sticker in set		
21PT1356/58	367	L01.2E	RCLE012	P-BGDK,S-BGDK		MONO	52x47x48	220-240V	TEDE9-004A	See sticker in set		
21PT1546/58	362	L01.2E	RCLE011	P-BGDKI,S-BGDKLL		MONO	52x50x49	220-240V	TEDE9-004A	See sticker in set		
21PT1556/21	367	L01.2E	RCLE011	P-BGDKI,S-BGDKLL		MONO	52x47x48	220-240V	UV1317/A I G-3	See sticker in set		
21PT1556/58	367	L01.2E	RCLE011	P-BGDK,S-BGDK		MONO	52x47x48	220-240V	TEDE9-004A	See sticker in set		
21PT1666/01	366	L01.2E	RCLE011	P-BGDKI,S-BGDKLL		MONO	55x47x50	220-240V	TEDE9-004A	See sticker in set		
21PT1666/05	366	L01.2E	RCLE011	P-BGI		MONO	55x47x50	220-240V	TEDE9-004A	See sticker in set		
21PT2001/59B	376	L01.2A	RC19335003/01	P-BGDK,S-BGDKK1	N-4,43(6.5)	MONO	61x57x59	90-276V	TEDE9-228B	0 215 65	0 194	9
21PT2001/79R	376	L01.2A	RC19335003/01	P-BGDKM,S-BGDKK1	N-4,43(6.5)	MONO	61x57x59	90-276V	TEDE9-228B	0 215 65	0 194	11
21PT2012/59A	375	L01.2A	RC19042001/01	P-BGDKM,S-BGDKK1	N-4,43(6.5)	MONO	68x58x57	90-276V	UV1356A/AG-3	0 247 65	0 194	80
21PT2012/59B	375	L01.2A	RC19042001/01	P-BGDKM,S-BGDKK1	N-4,43(6.5)	MONO	68x58x57	90-276V	UV1356A/AG-3	176 247 65	0 194	80
21PT2012/59C	375	L01.2A	RC19042001/01	P-BGDKM,S-BGDKK1	N-4,43(6.5)	MONO	68x58x57	90-276V	UV1356A/AG-3	176 247 65	0 194	80
21PT2012/79R	375	L01.2A	RC19042001/01	P-BGDKM,S-BGDKK1	N-4,43(6.5)	MONO	68x58x57	90-276V	UV1356A/AG-3	176 247 65	0 194	80
21PT2215/19TR	374	L01.1A	RC19335003/01	N-M/4,43(5.5)/4,43(6.5)		B-DBX,AV S	72x62x61	90-276V	TEDEH9-200A	160 215 193	162 242 144	36
21PT2215/256A	374	L01.1A	RC19042001/01	P-BGDKM,S-BGDKK1	N-M/4,43(5.5)/4,43(6.5)	AV S	72x62x61	90-276V	UV1356A/AG-3	160 247 193	162 242 144	44
21PT2215/257R	374	L01.1A	RC19042001/01	P-BGDKM,S-BGDKK1	N-M/4,43(5.5)/4,43(6.5)	AV S	72x62x61	90-276V	UV1356A/AG-3	176 247 193	164 242 144	44
21PT2215/268R	374	L01.1A	RC19042001/01	P-BGDKM,S-BGDKK1	N-M/4,43(5.5)/4,43(6.5)	AV S	72x62x61	90-276V	UV1356A/AG-3	176 247 193	164 242 144	44
21PT2215/269R	374	L01.1A	RC19042001/01	P-BGDKM,S-BGDKK1	N-M/4,43(5.5)/4,43(6.5)	AV S	72x62x61	90-276V	UV1356A/AG-3	176 247 193	164 242 144	44
21PT2215/279R	377	L01.1A	RC19335003/01	N-M/4,43(5.5)/4,43(6.5)		B-DBX,AV S	72x62x61	90-276V	TEDEH9-200A	160 215 193	162 242 144	36
21PT2302/56A	377	L01.1A	RC19042001/01	P-BGDKI,S-BGDKK1	N-M/4,43(5.5)/4,43(6.5)	N-BGDKI,2SC-BGDK,F-BG,AV S	72x62x61	90-276V	UV1356A/AG-3	160 247 193	168 254 144	44
21PT2302/57R	377	L01.1A	RC19042001/01	P-BGDKI,S-BGDKK1	N-M/4,43(5.5)/4,43(6.5)	N-BGDKI,2SC-BGDK,F-BG,AV S	72x62x61	90-276V	UV1356A/AG-3	160 247 193	168 254 144	44
21PT2302/68R	377	L01.1A	RC19042001/01	P-BGDKI,S-BGDKK1	N-M	N-BGDKI,2SC-BGDK,F-BG,AV S	72x62x61	90-276V	UV1356A/AG-3	176 247 193	168 254 144	44
21PT2302/69R	377	L01.1A	RC19042001/01	P-BGDKI,S-BGDKK1	N-M/4,43(5.5)/4,43(6.5)	N-BGDKI,2SC-BGDK,F-BG,AV S	72x62x61	90-276V	UV1356A/AG-3	176 247 193	168 254 144	44
21PT2302/79R	377	L01.1A	RC19042001/01	P-BGDKI,S-BGDKK1	N-M/4,43(5.5)/4,43(6.5)	N-BGDKI,2SC-BGDK,F-BG,AV S	72x62x61	90-276V	UV1356A/AG-3	176 247 193	168 254 144	44
21PT4406/01	341	L01.2E	RC19039001/01	P-BGDKI,S-BGDKLL		N-BGDKI,2SC-BGDK,F-BG,AV S	55x47x50	220-240V	TEDEH9-004A	See sticker in set		

Model number survey

MODEL	STYLING	CHASSIS	RC	SYSTEM P...=PAL S...=SECAM N...=NTSC	SOUND N...=NICAM F...=FM/FM	SIZE wxtxd (cm)	VOLTAGE TUNER	OPTION CODES 1 2 3	4	5	6	7	8
32PW9617/58	355	MG3.2E	RC2044/01B	P-BGDKI,S-BGDKLL'	N-BGDKIL,F-BG/Czech	85x55x54	220-240V	See sticker in set					
32PW9767/12	355	MG3.2E	RC2044/01B	P-BGDKI,S-BGDKLL'	N-BGDKIL,F-BG/Czech	85x55x54	220-240V	See sticker in set					
32PW9767/58	355	MG3.2E	RC2044/01B	P-BGDKI,S-BGDKLL'	N-BGDKIL,F-BG/Czech	85x55x54	220-240V	See sticker in set					
36PW9607/05	355	MG3.2E	RC2044/01B	P-BGDKI,S-BGDKLL'	N-BGDKIL,F-BG/Czech	94x61x58	220-240V	06012 12560 08003					
36PW9767/12	355	MG3.2E	RC2044/01B	P-BGDKI,S-BGDKLL'	N-BGDKIL,F-BG/Czech	94x61x58	220-240V	See sticker in set					
36PW9767/58	355	MG3.2E	RC2044/01B	P-BGDKI,S-BGDKLL'	N-BGDKIL,F-BG/Czech	94x61x58	220-240V	See sticker in set					
42PF9952/69S	235b	FTV1.9E	RC0333/01	P-BGDKI,S-BGDKLL'	N-BGDKIL,F-BG/Czech	122x67x16	90-276V	See sticker in set					
42PF9952/12M	235	F21RE/FTV1.9D	RC2042/01B	P-BGDKI,S-BGDKLL'	N-DBGDI,2SC-BGDK,AV S	122x67x16	95-264V	See sticker in set					
51TA1476/11	358	L01.2E	RCLE013	P-BGDKI,S-BGDKLL'	MONO	52x56x55	220-240V	See sticker in set					
52TA1476/11	361	L01.2E	RCLE013	P-BGDKI,S-BGDKLL'	MONO	52x50x49	220-240V	See sticker in set					
52TA4416/03	360	L01.2E	RCLE013	P-BGDKI,S-BGDKLL'	N-BGDKIL,F-BG,Mono	52x47x49	220-240V	See sticker in set					
63TA4416/03	363	L01.1E	RCLE013	P-BGDKI,S-BGDKLL'	N-BGDKIL,F-BG,Mono	76x51x58	220-240V	See sticker in set					
63TA4416/11	363	L01.1E	RCLE013	P-BGDKI,S-BGDKLL'	N-BGDKIL,F-BG,Mono	76x51x58	220-240V	See sticker in set					
70TA4416/03	344	L01.2E	RCLE013	P-BGDKI,S-BGDKLL'	N-BGDKIL,F-BG,Mono	77x58x48	220-240V	See sticker in set					
70TA4416/11	344	L01.2E	RCLE013	P-BGDKI,S-BGDKLL'	N-BGDKIL,F-BG,Mono	77x58x48	220-240V	See sticker in set					
ETR9964/01S	334	F21RE	RC2042/01B	P-BGDKI,S-BGDKLL',N-M	N-BGIL,2SC-BGDK,Mono	44x10x33	85-264V	See sticker in set	00016	12343	00001	00000	00518

Personal Notes

STYLING 229

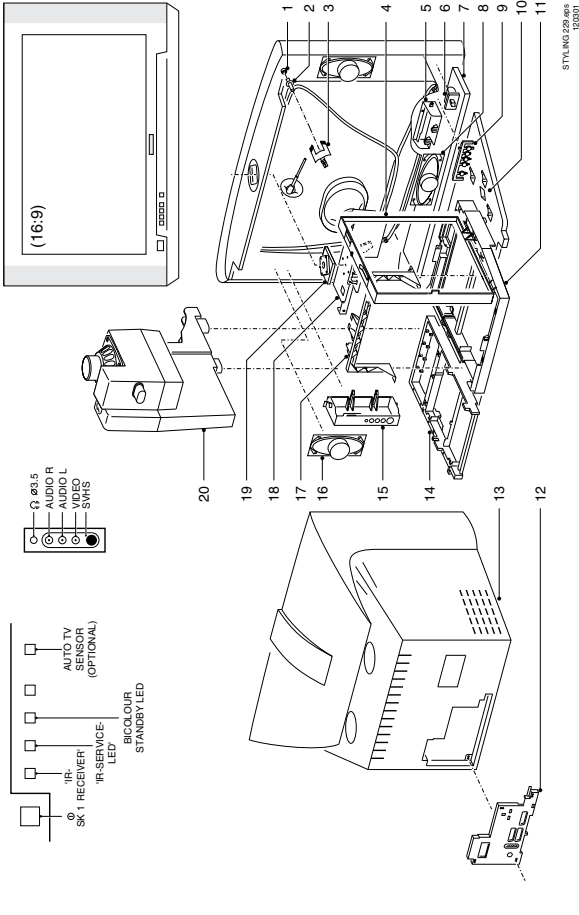

STYLING 229 (16:9)

1	4822 404 31294	Insert 32" VP19100	3104 304 19640	SSP	3104 304 19640	Module support bracket on
2	4822 505 11195	Picture tube screw 28"	3104 304 20300	Bracket for DAF panel	3104 304 20300	SSP
3	4822 502 21359	Picture tube screw 32"	2322 460 91643	DAF potmeter	2322 460 91643	DAF potmeter
4	4822 403 70906	Bracket fix deg. coil (2x) 28"	2422 549 44248	Degaussing coil	2422 549 44248	Degaussing coil
5	4822 404 31289	Bracket fix deg. coil (2x) 32"	2422 549 44248	Degaussing coil	2422 549 44248	Degaussing coil
6	3104 304 21091	Bracket fix deg. coil (2x) 36"	8204 000 74951	Degaussing coil	8204 000 74951	Degaussing coil
7	3104 304 21091	Frame for supply panel	4822 157 11825	Rotation coil	4822 157 11825	Rotation coil
8	3104 304 19650	Bracket mains unit	3104 304 21031	Bracket for rotation coil	3104 304 21031	Bracket for rotation coil
9	4822 402 11176	Mains knob	9301 827 70306	Picture tube W76ERF031X44	9301 827 70306	Picture tube W76ERF031X44
10	3104 304 20790	Mains knob	9301 828 00306	Picture tube W66ERF031X44	9301 828 00306	Picture tube W66ERF031X44
11	3104 307 95240	Cabinet	9322 173 93682	Remote control RC2033/01B	9322 173 93682	Remote control RC2033/01B
12	3104 328 08671	Cabinet	3104 207 09580	Remote control RC2020/01B	3104 207 09580	Remote control RC2020/01B
13	3104 328 04820	Cabinet	3104 207 09540	Remote control RC2035/01	3104 207 09540	Remote control RC2035/01
14	3104 328 08971	Cabinet V0	4622 009 50772	Mains cord	4622 009 50772	Mains cord
15	3104 328 06362	Cabinet V0	2422 009 50782	Mains cord -05	2422 009 50782	Mains cord -05
16	3104 328 13971	Cabinet V0	2422 070 98129	Mains cord -79R	2422 070 98129	Mains cord -79R
17	3104 328 16211	Cabinet	2422 070 98132	Wireless surround set	2422 070 98132	Wireless surround set
18	3104 328 20541	Cabinet	3104 130 01181	864MHz Eur	3104 130 01181	864MHz Eur
19	2422 257 20547	Cabinet	3104 130 01301	Wireless surround set	3104 130 01301	Wireless surround set
20	3104 304 20800	Light guide	3104 130 01251	433MHz Eur	3104 130 01251	433MHz Eur
1	3104 304 12141	Bottom plate	3104 300 20201	Wireless surround set	3104 300 20201	Wireless surround set
2	3104 304 19580	Bottom plate V0	3135 017 00921	863MHz UK	3135 017 00921	863MHz UK
3	4822 466 12101	Frame for LSP	3104 307 97811	Adapter F-pin - IEC	3104 307 97811	Adapter F-pin - IEC
4	3104 304 30980	Coverplate	3104 300 20181	Demo pin	3104 300 20181	Demo pin
5	4822 466 12209	Coverplate	3104 300 20191	Cable IR shooter	3104 300 20191	Cable IR shooter
6	3104 307 94313	Coverplate	28PW9616	Cover mains harmonic for	28PW9616	Cover mains harmonic for
7	3104 307 95302	Coverplate	32PW9525	-79R sets	32PW9525	-79R sets
8	3104 307 97831	Coverplate	3104 300 20191	Euro to cinch/SVHS adapter	3104 300 20191	Euro to cinch/SVHS adapter
9	3104 307 97831	Rear cover	28PW9616	Euro to 3 x cinch adapter for	28PW9616	Euro to 3 x cinch adapter for
10	3104 307 95250	Rear cover V0	32PW9525	-79R	32PW9525	-79R
11	3104 307 95250	Rear cover V0	3104 300 20181	Key pad	3104 300 20181	Key pad
12	3104 307 95821	Frame for SSP	28PW9616	Key pad	28PW9616	Key pad
13	3104 304 10474	Bracket side IO	32PW9525	Key pad	32PW9525	Key pad
14	3104 304 20990	Bracket side IO	3104 304 20921	Subwoofer box	3104 304 20921	Subwoofer box
15	3104 130 01230	Lot support bracket	4822 445 10834	Philips emblem 28"	4822 445 10834	Philips emblem 28"
16	3104 304 20260	Bracket top control	4822 454 13455	Philips emblem 32"	4822 454 13455	Philips emblem 32"
17	4822 464 10475	Key pad	4822 454 13399	Philips emblem	4822 454 13399	Philips emblem
18	3104 304 21630	Key pad	4822 459 11161	Matchline emblem	4822 459 11161	Matchline emblem
19	3104 304 20921	Key pad	3104 300 12080	Matchline emblem 28PW9525	3104 300 12080	Matchline emblem 28PW9525
20	3104 304 22961	Key pad	4822 459 11033	Spring mains switch	4822 459 11033	Spring mains switch
e*	4822 445 10834	Subwoofer box				
	4822 454 13455	Philips emblem 28"				
	4822 454 13399	Philips emblem 32"				
	4822 459 11161	Philips emblem				
	3104 300 12080	Matchline emblem				
	4822 459 11033	Matchline emblem 28PW9525				

STYLING 235a

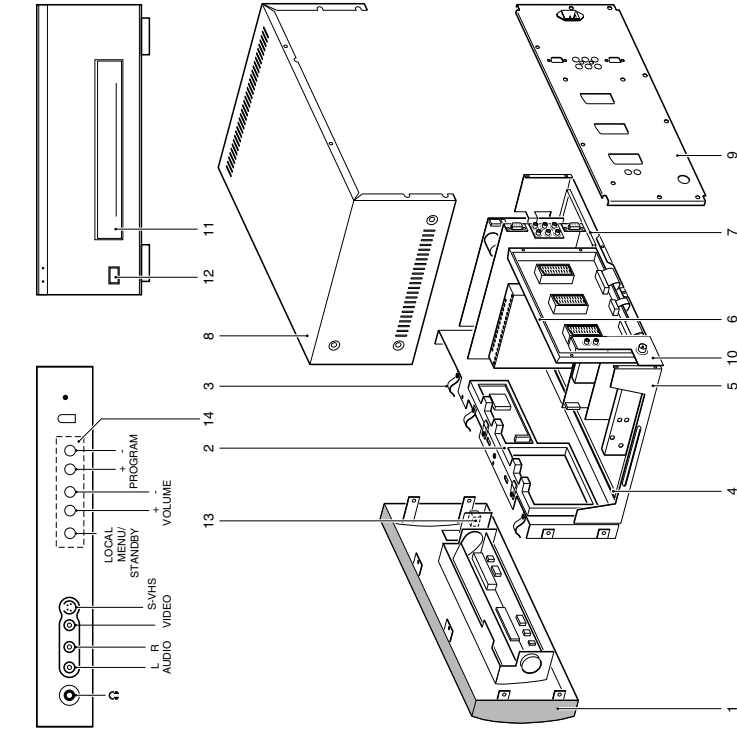

STYLING 235a (16:9)

1	3122 128 13063	Front panel	3122 128 13001	Connector PL
2	3122 124 35641	TXT bracket	3122 128 13081	Top plate painted
3	3122 121 66971	EMC spring front I/O	Not applicable	
4	3122 124 35571	4 PCB bracket	3122 128 13012	Door
5	3122 121 35642	Bottom plate	3122 128 13131	Mains knob
6	3122 124 35601	Rear I/O-bracket	3122 124 35612	Lightguide
7	3122 124 35631	SSP bracket	3104 308 76481	Control knob Assy
8	3122 128 13081	Top plate painted	3139 117 72651	Wordmark PHILIPS
9	3122 128 13001	Connector PL	9322 127 27676	IR LED
10	Not applicable		3122 121 35631	Front shield
11	3122 128 13012	Door	3104 308 76481	Front connections
12	3122 128 13131	Mains knob	3139 117 85331	Leg silver
13	3122 124 35612	Lightguide	3104 304 16374	SSP locking unit
14	3104 308 76591	Control knob Assy	3104 317 91971	Box supply MEDAP
	3139 117 72651	Wordmark PHILIPS	4622 007 51971	Mains cord FTR952/12
	9322 127 27676	IR LED	2422 070 98107	Mains cord FTR952/19

STYLING 235b

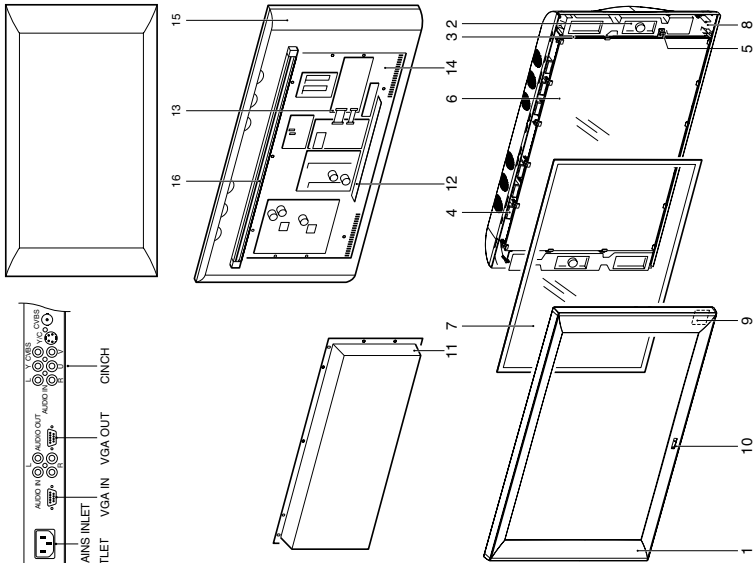
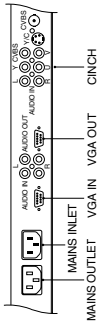

STYLING 235b-A1
070700

1	3122 128 13171	Screen frame gray (monitor-only configuration)	15	3122 128 13181	Back display (monitor-only configuration)
1	3122 357 20541	Screen frame purple	16	3122 121 66951	Mount profile
1	3122 357 20551	Screen frame blue		3122 121 66961	Wall mount profile
1	3122 357 20561	Screen frame green		4822 310 11182	Mounting kit assembly
1	3122 357 20571	Screen frame champagne		4822 263 50216	MAC adapter
1a*	3122 128 13162	Screen frame silver		4822 462 10981	Wall spacer
2	3104 130 01391	Loudspeaker assembly		3122 121 66971	EMC spring
3	3122 121 66931	EMC strip	ab*	3122 121 67021	EMC strip
4	3104 301 09352	Fan	ab*	2422 070 98107	Mains cord UK/FR
5	3122 121 35601	Glass clip		4622 007 51971	Mains cord WE
6	9322 137 15682	Display	c*	3122 358 75802	Mains cord
7	3122 124 90741	Glass plate		3122 358 75921	VGA cable 2m
8	3122 128 13141	Mains knob		3122 358 75931	VGA cable 5m
9	3122 124 35651	Light guide		3122 358 76021	VGA cable 10m (only total configuration)
10	3104 300 11991	Wordmark-PHILIPS			
11	3122 128 13031	Board encasing	*a	42PF952/12S, /19S	
12	3122 128 13121	Connector plate	*b	42FD9932/01G, /01S	
13	2422 015 13083	PCB hinged lock	*c	42FD9932/17G	
14	3122 121 35611	Back cover			
15	3122 124 35561	Back display (only total configuration)			

STYLING 252

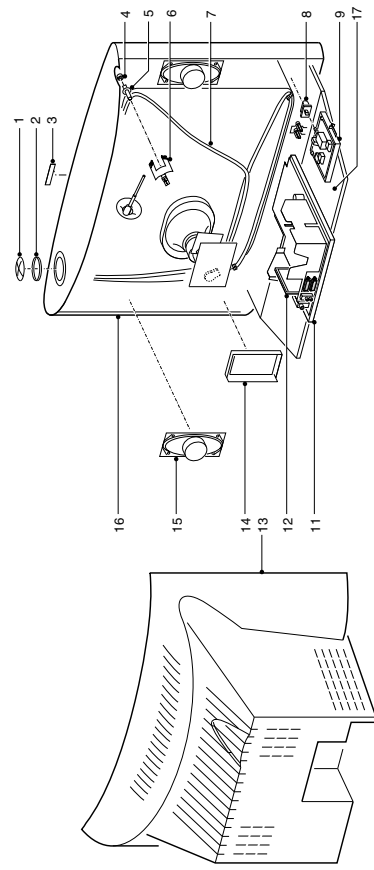
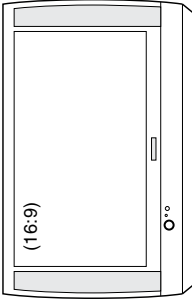
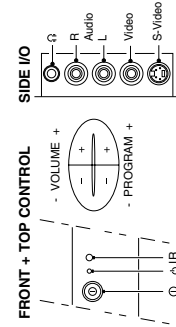

STYLING 252-APP
260601

1/2abc*	3139 178 61961	Top control assy	13c*	3111 257 55702	Rear cover 24" WS
1/2def*	3139 178 86551	Top control assy	13df*	3139 124 34622	Rear cover 28" WS
3a*	3111 250 00621	Wordmark 32", 24"	13e*	3139 124 34632	Rear cover 32" WS
3bcd*	3111 250 00201	Wordmark 28", 24"	14	3104 304 22191	Bracket for Side I/O panel
3e*	3104 300 11831	Wordmark 32"	15aef*	2422 264 00381	Speaker 8Ω, 10W
3f*	3111 250 00271	Wordmark ARISTONA (/03)	15bcd*	4822 240 10368	Speaker YDT0613-62BP
3f*	3111 250 00261	Wordmark SBR (/11)	16ae*	3111 257 55692	Cabinet painted 32" WS
3f*	3111 250 00221	Wordmark RAD/OLA (/18)	16e*	3111 257 55632	Cabinet painted 32"
4*	Not applicable		16bd*	3111 257 55681	Cabinet painted 28" WS
5abdef*	4822 502 14602	CRT screw 28", 32"	16d*	3139 124 34622	Cabinet painted 28" WS
5c*	4822 502 14071	CRT screw 24"	16f*	3111 257 56241	Cabinet painted 28" WS (Nat. brand)
6a*	3104 308 77010	Coil bracket	16c*	3111 257 55671	Cabinet painted 24" WS
6abef*	3111 254 24611	Corner coil bracket	17bd*	3139 124 26412	Bottom plate 28"
6c*	3104 304 18634	Corner coil bracket	17c*	3139 124 26422	Bottom plate 24"
6d*	3139 124 34622	Corner coil bracket		4822 321 11139	Mains cord EU
6abdef*	3111 254 23481	Coil & EHT clamp		4822 321 11143	Mains cord UK
7ae*	2422 549 44564	Degaussing coil 32"		9322 148 59682	Picture tube 32"
7bdf*	2422 549 44248	Degaussing coil 28"		W76EGV023X315	Picture tube 28"
7c*	2422 549 44563	Degaussing coil 24"		W66ECK001X14	Picture tube 24"
8ab*	3139 137 75631	Mains knob		9301 770 70307	Picture tube 24"
8def	3139 137 52412	Mains knob		9301 760 20347	Picture tube 24"
8c*	3139 137 75621	Mains knob			W56ECK001X04
9	Not applicable				
10c*	4822 380 10239	Light guide 24"			
10abdef*	4822 380 10238	Light guide 28", 32"			
11	3139 124 32541	Bracket for LSP			
12	3139 124 33361	Supporting bracket for SSB			
13a*	3139 124 31761	Rear cover 32" WS			
13b*	3139 124 31742	Rear cover 28" WS			

*a 32PW6005
*b 28PW6005
*c 24PW6005
*d 28PW5405
*e 32PW5405
*f 70WA6215

STYLING 260

FRONT + TOP CONTROL



SIDE I/O

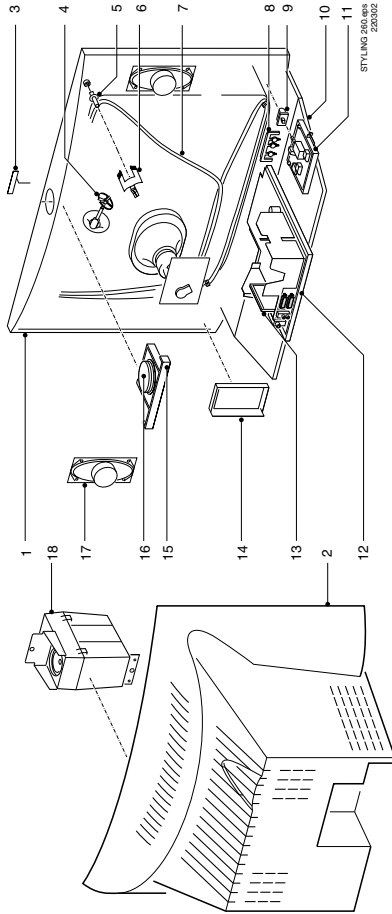
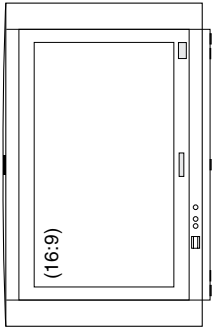
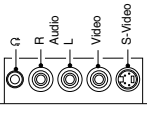

1ab*	3111 257 57121	Cabinet painted 28"	15ac*	3139 124 30381	Top control bracket
1cd*	3111 257 57131	Cabinet painted 32"	15bd*	3139 124 33941	Top control bracket
2ab*	3111 257 56671	Rear cover 28"	16	3139 137 66921	Top control button
2cd*	3111 257 56681	Rear cover 32"	17ac*	2422 264 00377	Loudspeaker 8Ω 10W
3a*	3111 250 00731	Wordmark 28"	17b*	3139 128 76202	Loudspeaker 8Ω 10W
3b*	4822 454 13455	Wordmark 28"	17d*	2422 257 20547	Loudspeaker 8Ω 15W
3c*	3111 250 00581	Wordmark 32"	18ac*	3139 128 75771	Subwoofer
3d*	3111 250 00811	Wordmark 32"	18bd*	3139 128 76372	Subwoofer
4ab*	4822 401 11765	Coll & EHT bracket	ab*	9301 805 90301	Picture tube 28"
4b*	4822 404 31341	Coll & EHT bracket	cd*	9301 800 90314	Picture tube 32"
4c*	4822 404 31289	Coll & EHT bracket			W76ERF001X013
5ab*	4822 505 11195	CRT screw 28"			Mains cord EU
5cd*	4822 502 14602	CRT screw 32"			Mains cord UK
6	4822 403 70906	Corner coil bracket			VO insulator ring
7a*	2422 549 44248	Degaussing coil 28"			Mains harmonic bracket
7b*	2422 549 44621	Degaussing coil 28"	*a	28PW6515	
7cd*	2422 549 44244	Degaussing coil 32"	*b	28PW6516/79R	
8ac*	3139 124 30411	Light guide	*c	32PW6515	
8bd*	3139 124 33611	Light guide	*d	32PW6516/79R	
9	3139 124 33801	Mains knob			
10	Not applicable	Bracket for Front control panel			
11	3139 124 32521	Bracket for LSP			
12	3139 124 32542	Supporting bracket for SSB			
13	3139 124 33361	Bracket for Side I/O panel			
14	3139 124 31651				

STYLING 261

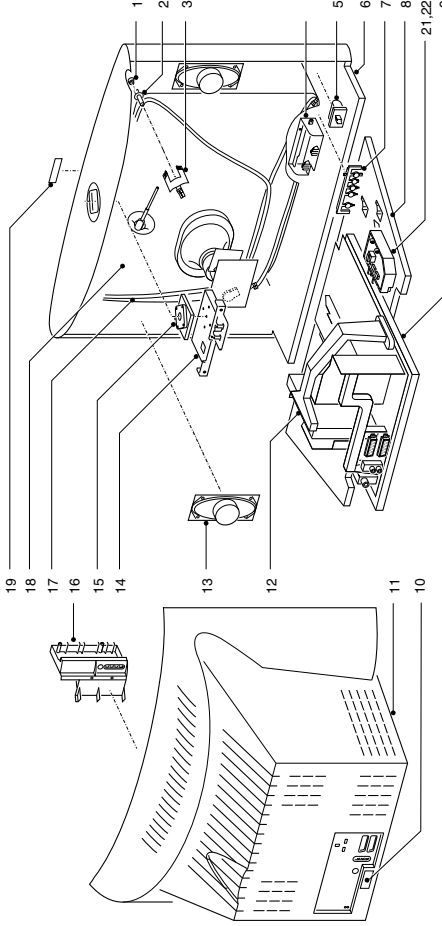
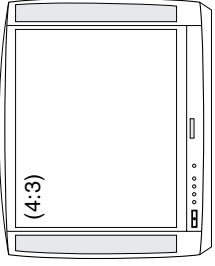
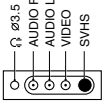
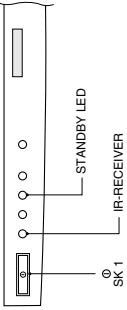

1	Not applicable	Picture tube screw	16abe*	4822 402 11175	Bracket Side I/O panel
2	4822 505 11195	Bracket fix deg. coil	16cd*	3104 304 22111	Bracket Side I/O panel
3	4822 403 70906	Bracket mains unit	16f*	3104 304 25151	Degaussing coil
4	4822 402 11176	Mains knob	17	2422 549 44385	CRT 25"
5abe*	4822 410 12069	Mains knob	18a*	9301 735 10306	9301 732 90303
5cd*	3104 307 95961	Mains knob	18bcdelf*		CRT 28"
5f*	3104 307 99561	Mains knob	19abe*	4822 459 11127	Wordmark Philips
6a*	3104 328 01612	Cabinet assy	19c*	4822 250 00291	Wordmark Philips
6b*	4822 449 80289	Cabinet assy	19d*	4822 454 13462	Wordmark Aristona (03)
6c*	3104 328 06052	Cabinet assy	19d*	3122 220 00623	Wordmark SBR (/11)
6d*	3104 328 07142	Cabinet assy	19f*	4822 454 13455	Wordmark Philips
6e*	3111 257 56372	Cabinet assy	20	3104 304 22751	Bracket Mains harmonic (only for xxxR)
6f*	3104 328 20731	Cabinet assy	21	3104 304 22762	Cover Mains harmonic (only for xxxR)
7a*	3104 304 19722	Light guide			SSB shielding (top)
7bcdelf*	3104 304 19812	Light guide			SSB shielding (bottom)
8a*	3104 304 21264	Bottom plate			Mains cord
8bcdelf*	3104 304 21274	Bottom plate			Mains cord holder
9	3104 304 21303	Bracket LSP	*a	25PT7106	
10acd*	3104 304 21641	Service connector cover	*b	28PT7106	
10be*	3104 304 21772	Service connector cover	*c	28PT7306	
10f*	3104 304 22312	Service connector cover	*d	70TA7216	
11a*	3104 328 06092	Rear cover	*e	28PT7007/12	
11be*	3104 328 06112	Rear cover	*f	28PT7157/12	
11cd*	3104 328 06101	Rear cover	*g	28PT7207/12	
11f*	3104 328 20751	Rear cover			
12	3104 304 21112	Support bracket LOT/SSB			
13	4822 240 10331	Loudspeaker			
14	4822 464 10475	Bracket Top control panel			
15abe*	3104 304 21711	Keypad			
15cd*	3104 304 22121	Keypad			
15fg*	3104 304 20921	Keypad			

STYLING 260/261
200302

STYLING 284

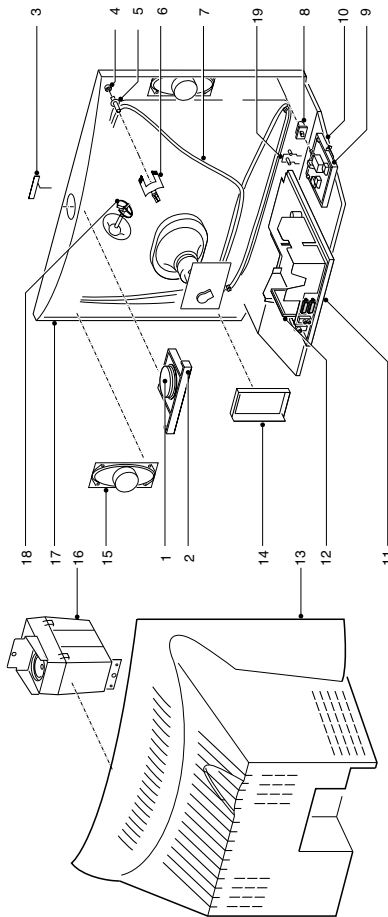
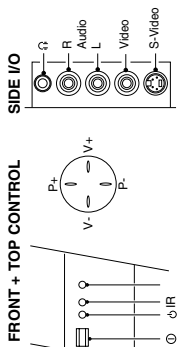
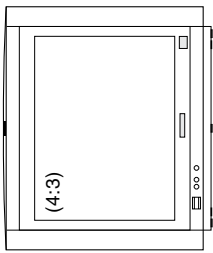

STYLING 284.695
1B/201

1/2a*	3139 178 82271	Top control assy	13ab*	3111 257 56641	Rear cover 29"
1b*	3139 137 66921	Top control button	14ab*	3111 257 56641	Bracket for Side I/O panel
2b*	3139 124 33941	Top control bracket	15	2422 264 00379	Loudspeaker
3a*	3111 250 00571	Wordmark 29"	16	3139 128 76373	Subwoofer
3b*	3141 050 00161	Wordmark 29" PHILLIPS	17a*	3111 257 57111	Cabinet 29"
4	Not applicable		17b*	3139 138 14921	Cabinet 29"
5ab*	4822 505 11195	CRT screw	18ab*	3111 254 23481	Coil & EHT clamp
6	3139 124 31121	Bracket fix degaussing coil	19ab*	3139 124 33811	Light guide
7ab*	2422 549 44579	Degaussing coil	ab*	4822 321 11139	Mains cord
8a*	3139 137 72011	Mains knob assy	b*	4822 404 31291	Mains cord holder
8b*	3139 124 33801	Mains knob		4822 53213136	VO insulator ring
9ab*	3139 124 32521	Bracket for Front control panel	a*	3111 259 00111	Picture tube 29" A68QCP891X604
10	Not applicable		b*	9322 177 18682	Picture tube 29" A68QCP891X628
11ab*	3139 124 32542	Bracket for LSP	a	29PT5515	
12ab*	3139 124 33361	Supporting bracket for SSB	b	29PT5516	

STYLING 291

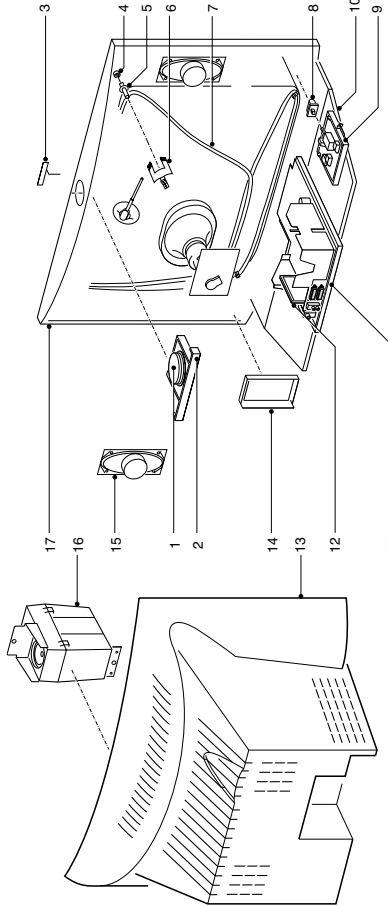
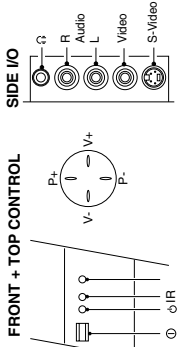
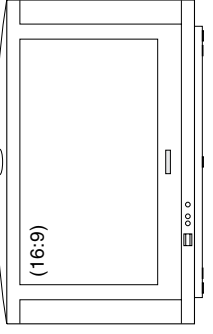

STYLING 291.695
1B/01

1	3139 124 31131	Top control cover	17c*	3111 257 56823	Cabinet 28"
2	3139 124 33941	Top control bracket	17b*	3111 257 57151	Cabinet 32"
3ac*	3111 250 00591	Wordmark	17d*	3111 257 57192	Cabinet 32"
3b*	3111 250 00601	Wordmark		3139 124 35291	Mains harmonic bracket
3d*	3104 300 11831	Wordmark		3139 124 31631	Light guide
4	Not applicable			4822 404 31291	Mains cord relief
5	4822 502 14602	CRT fixing screw	a*	9322 148 60682	Picture tube 28"
6	4822 403 70906	Degaussing coil 28"	b*	4822 131 11215	Picture tube 32"
7	4822 157 11758	Degaussing coil 28"	c*	4822 131 11345	Picture tube 28"
7b*	2422 549 44564	Degaussing coil 32"	d*	9322 148 59682	Picture tube 32"
8	3139 124 32511	Mains knob		4822 321 11139	Mains cord
9	3139 124 32521	Front interface bracket		28PW6305	
10	Not applicable			28PW6305	
11	3139 124 32542	Chassis tray		28PW5406	
12	3139 124 33361	SSB bracket	a*	32PW5406	
13a*	3139 137 69971	Rear cover 28"	b*	32PW5406	
13c*	3139 137 90761	Rear cover 28"	c*		
13b*	3139 137 70071	Rear cover 32"	d*		
13d*	3139 137 90731	Rear cover 32"			
14abc*	3139 124 31651	Side I/O bracket			
14d*	3139 124 33131	Side I/O bracket blue silver			
15	2422 264 00377	Loudspeaker 8Ω 10W			
16	Not applicable				
17a*	3111 257 57141	Cabinet 28"			

STYLING 297

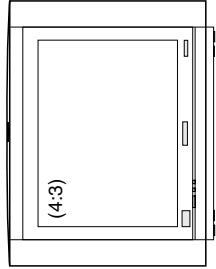

FRONT + TOP CONTROL

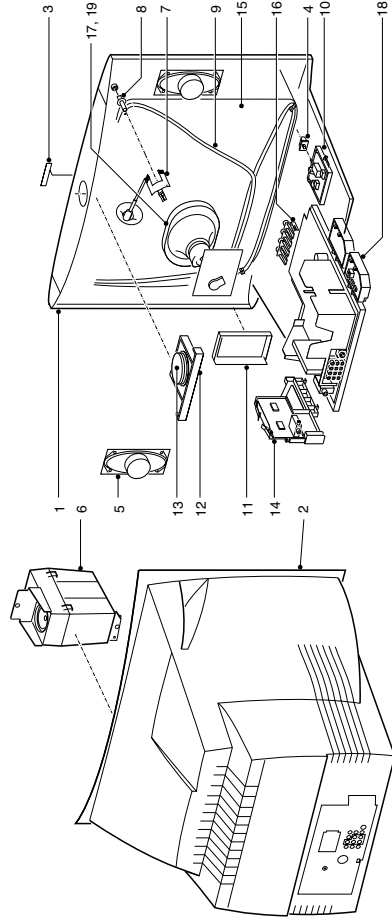
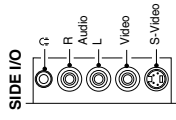
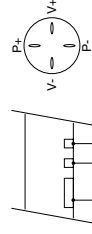

STYLING 297 PARTS LIST

1a*	3139 137 71101	Cabinet	9322 173 75682	CRT A68QCP893X001 (29" not for /73 & /79) SAMS
1a*	3139 137 90611	Cabinet (79B only)	9322 174 24682	CRT A68QCP893X005 (29" /73 & /79 only) SAMS
1b*	3139 137 98831	Cabinet	9322 156 43682	CRT M79LOM187X01 (34" /79 only) MEC
1c*	3139 137 74931	Cabinet (MEC tube only)	9322 175 69682	CRT A60LTM350X11 (94" /56, /57, /61 & /97 only) TOSB
1d*	3139 137 91951	Cabinet (TOSB tube only)	9322 175 68682	CRT A80LTM351X11 (34" /69 & /71 only) TOSB
1e*	3139 137 94971	Rear cover	3139 137 84471	Control knob Assy
2a*	3139 124 31431	Rear cover (w/o YUV input)	3139 128 23811	Rotation coil (29" & 34")
2b*	3139 124 31401	Rear cover (with YUV input)	4822 402 11113	DAF bracket
2c*	3139 124 31422	Rear cover	19abd*	Rotation coil bracket (29" only)
2d*	3139 124 35611	Rear cover	0017	DVD badge
3abd*	3141 050 00161	Wordmark PHILIPS	0018	DVD eject knob Assy
3c*	3139 137 64701	Mains knob Assy	0019	DVD door Assy
4acd*	3139 137 83951	Mains knob Assy	0047	Antenna mixer (/61, /71 & /97 only)
5af*	2422 264 00379	Speaker 8Ω 10W	0049	Mains adaptor socket (/61 only)
5b*	2422 264 00403	Speaker 8Ω 10W	0072	Light guide
5cd*	2422 264 00377	Subwoofer box	0082	Mains cord relief
6acd*	3141 058 63441	(shielded cable)	0189	Heat-sink clamp bracket
7abdf*	3139 124 31122	Degaussing coil bracket	0313	Spacer for EHT cable
7c*	3139 124 32811	Degaussing coil bracket	1322 504 97401	Grease for EHT cap
8	3111 250 40031	CRT screw		
9abd*	3139 128 23781	Degaussing coil		
9c*	3139 128 23801	Degaussing coil (MEC tube)		
10acd*	3139 128 23821	Degaussing coil (TOSB tube)		
10bd*	3139 124 30432	Front interface bracket		
11acd*	3139 124 33461	Side AV bracket (not for /79B)		
11d*	3139 124 34671	Side AV bracket - Black (/79B only)		
11b*	3139 124 33611	Side AV bracket (dummy)		
12acd*	3139 124 30381	Top control bracket		
13acd*	3139 137 66921	Top control button Assy		
14ac*	3139 124 31671	Double window bracket		
14d*	3139 124 33571	DVD interface bracket		
15	9322 173 75682	CRT A68QCP893X001 (29" not for /73 & /79) SAMS		
15	9322 174 24682	CRT A68QCP893X005 (29" /73 & /79 only) SAMS		
15	9322 156 43682	CRT M79LOM187X01 (34" /79 only) MEC		
15	9322 175 69682	CRT A60LTM350X11 (94" /56, /57, /61 & /97 only) TOSB		
15	9322 175 68682	CRT A80LTM351X11 (34" /69 & /71 only) TOSB		
16bd*	3139 137 84471	Control knob Assy		
17	3139 128 23811	Rotation coil (29" & 34")		
18c*	4822 402 11113	DAF bracket		
19abd*	3139 124 39581	Rotation coil bracket (29" only)		
0017	3139 240 00041	DVD badge		
0018	3139 137 91461	DVD eject knob Assy		
0019	3139 137 88931	DVD door Assy		
0047	3139 128 72421	Antenna mixer (/61, /71 & /97 only)		
0049	3139 118 71853	Mains adaptor socket (/61 only)		
0072	3139 124 30411	Light guide		
0082	3122 224 04623	Mains cord relief		
0188	3122 224 04242	Heat-sink clamp bracket		
0189	3139 124 30531	Small signal board bracket		
0313	3139 124 17541	Spacer for EHT cable		
	1322 504 97401	Grease for EHT cap		
*a	29PT6361	DVD module partlist, refer to service manual 3122 785 10840		
*b	29PT6021			
*c	34PT6361			
*d	29PT6961			
†	29PT6341			

STYLING 298

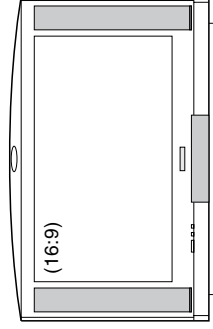

FRONT + TOP CONTROL

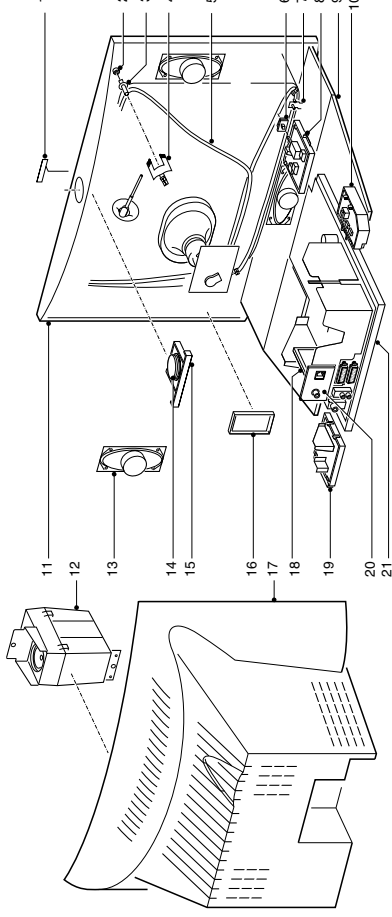
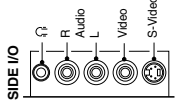
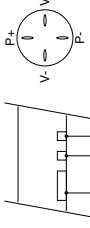

STYLING 298 PARTS LIST

1	3111 250 00811	Wordmark 32" silver Philips	18	3139 124 33361	SSB bracket
1	3111 250 00731	Wordmark 28" silver Philips	19	3139 124 34031	Dolby interface backplate
2	Not applicable		21	3139 124 31631	Lightguide
3	4822 502 14602	CRT fixing screw		4822 402 11183	Mains cord holder
4	4822 403 70906	Corner coil bracket		2422 070 98089	Mains cord
5	4822 157 11758	Degaussing coil 28"		4822 321 11143	Mains cord UK
5	2422 549 44564	Degaussing coil 32"	ab*	4822 157 11825	Canceller coil 32"
6	3139 124 32511	Mains knob		4822 131 11345	Picture Tube 28"
8	3139 124 32521	Front interface	c*		W66ECK001X14
9	3139 124 35291	Mains harmonic bracket (32" only)		4822 131 11215	Picture Tube 32"
			d*	9322 148 59682	W76ESF031X14+
10ab*	3111 257 57161	Cabinet 28"			Picture Tube 32"
10c*	3111 257 57171	Cabinet 32"			W76EGV023X315
11	3139 178 89221	Subwoofer	*a	28PW6315/01	
12	2422 264 00377	Loudspeaker 8Ω 10W	*b	28PW6315/05	
13	3139 137 66921	Top control button	*c	32PW6315/01, /05	
			*d	32PW6315/21, /25	
14	3139 124 33941	Top control bracket			
15	3139 124 31651	Side I/O bracket			
16	3111 257 56751	Rear cover 28"			
16	3111 257 56761	Rear cover 32"			
17	3139 124 33151	Dolby prologic bracket			

STYLING 299

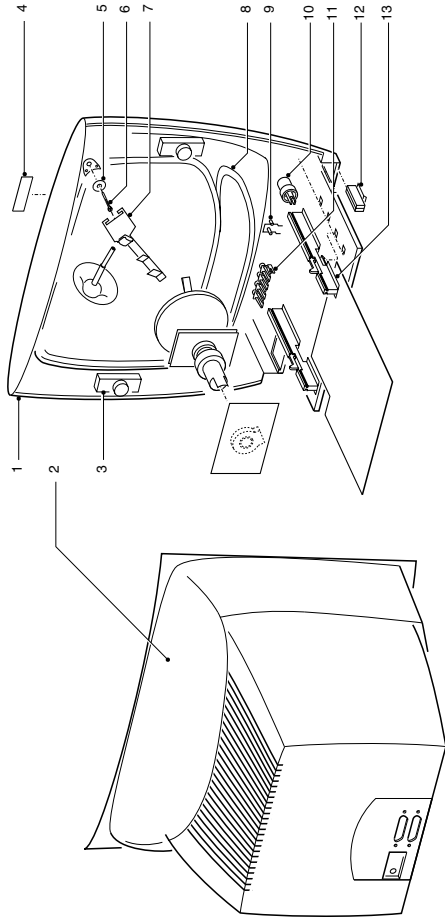
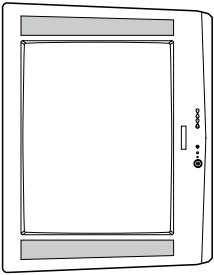
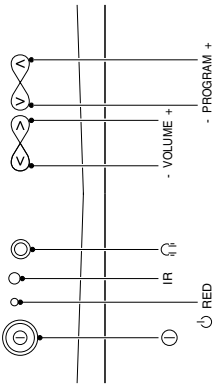

STYLING 299/298
160101

- 1 3111 257 57201 Cabinet 28"
- 2 3139 137 88991 Rear cover 28"
- 3 4822 240 10368 Loudspeaker 16Ω 5W
- 4 4822 459 11155 Wordmark Philips
- 6 4822 505 11195 CRT fixing screw
- 7 4822 157 11762 Degaussing coil bracket 28"
- 8 4822 157 11762 Degaussing coil 28"
- 9 4822 380 10251 Light guide
- 10 3139 124 30561 Mains knob
- 11 4822 410 11765 Control knob
- 12 4822 404 31363 Mains cord relief
- 13 3139 124 30871 Chassis guide (HB)
- 13 3139 124 30881 Chassis guide (VO)
- 4822 321 11493 Mains cord UK
- 4822 321 11499 Mains cord
- 4822 403 70906 Corner coil bracket
- 4822 131 20559 Picture tube 28"

28PT5505/01

STYLING 301

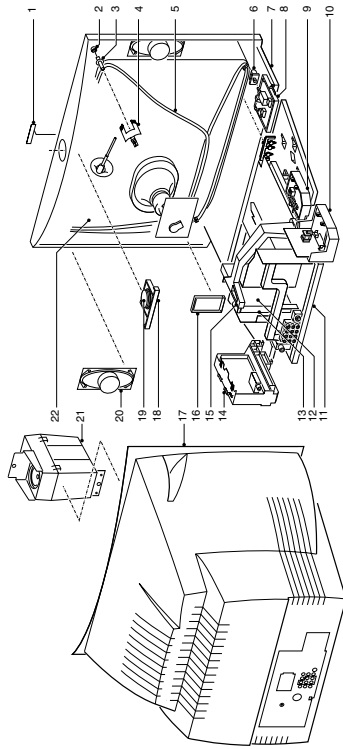
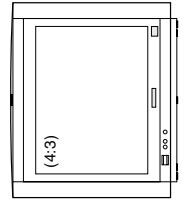
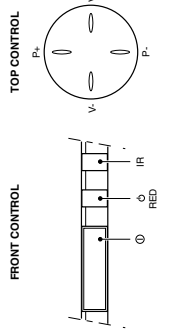

STYLING 301/300
200001

- | | | | | | |
|-----------|----------------|--------------------------------|----------|----------------|-----------------------------|
| 1 | 4822 454 13455 | Wordmark | 18kl* | 3139 178 60461 | Top Control assy |
| 2 | Not applicable | CRT insert | 19 | 3104 307 97181 | Top Control keypad assy |
| 3 | 4822 505 11195 | CRT screw | 19hijkl* | 3139 137 66921 | Top Control keypad assy |
| 4 | 3139 124 31121 | Degaussing coil fixing bracket | 20 | 3139 128 76081 | Loudspeaker assy |
| 5 | 4822 157 11708 | Degaussing coil | 21 | 9099 291 10017 | Subwoofer assy |
| 5h* | 2422 549 44675 | Degaussing coil | 22abcdg* | 9322 160 14682 | Picture tube A66GCCP891X500 |
| 5ijkl* | 3139 128 23781 | Degaussing coil | 22b* | 9322 160 16682 | Picture tube A66GCCP891X501 |
| 6 | 3104 307 96741 | Mains knob assy | 22i* | 9322 160 16682 | Picture tube A66GCCP891X502 |
| 6h* | 3104 307 97651 | Mains knob assy | 22hi* | 3104 309 16301 | Picture tube A66GCCP891X500 |
| 7 | 3104 328 08451 | Cabinet assy | 22jkl* | 3104 309 16311 | Picture tube A66GCCP891X501 |
| 7h* | 3104 328 12351 | Cabinet assy | a* | 4622 007 51852 | Mains cord |
| 7i* | 3104 328 13541 | Cabinet assy | bg* | 2122 070 98131 | Mains cord |
| 7k* | 3104 328 15291 | Cabinet assy | c* | 4822 321 11499 | Mains cord |
| 7l* | 3104 328 12981 | Cabinet assy | f* | 3139 128 75231 | Mains cord |
| 8 | 3139 124 30431 | Bracket for Mains Switch | h* | 3104 328 16451 | Mains cord |
| 8h* | 3139 124 32891 | Bracket for Mains Switch | i* | 3139 128 75251 | Mains cord |
| 8ijkl* | 3139 124 32521 | Bracket for Mains Switch | j* | 3139 128 75291 | Mains cord |
| 9 | 3139 124 33211 | Bracket for Mains Harmonic | k* | 3139 128 75672 | Mains cord |
| 10 | 3104 304 21652 | Bracket for DAF/DC-shift | l* | 3139 128 75261 | Mains cord |
| 11 | 3104 304 22832 | Bracket for Large Signal | ijkl* | 3122 224 04623 | Mains cord holder |
| 12 | 3104 301 24011 | Shielding SSB (bottom cover) | hijkl* | 3139 124 30411 | Mains cord holder |
| 12hijkl* | 3104 301 24051 | Shielding SSB (top cover) | h* | 3139 124 32791 | Light guide |
| 13 | 3104 301 24002 | Bracket for PIP/Multivoltage | ijkl* | 3139 124 33011 | Mains knob shaft |
| 14cdefgk* | 3104 304 22073 | Bracket for PIP/Multivoltage | h* | 4822 157 11825 | Mains knob shaft |
| 14h* | 3104 304 22431 | Bracket for PIP/DW panel | h* | 3128 138 60651 | Rotation coil |
| 14ijkl* | 3104 304 23801 | Bracket for PIP | hijl* | 3104 304 21321 | Rotation coil |
| 15 | 3104 304 21114 | Bracket for LOT/SSB | kl* | 3104 308 78171 | Cover plate YpbPr |
| 16 | 3139 124 36361 | Bracket for Side I/O panel | kl* | 2422 031 10912 | Adapter IEC/F-connector |
| 17ab* | 3104 328 12421 | Rear cover assy | a | 29PT8319/67R | Adapter 300/750 |
| 17c* | 3104 307 99121 | Rear cover assy | b | 29PT8319/69R | |
| 17d* | 3104 328 12991 | Rear cover assy | c | 29PT8419/57R | |
| 17e* | 3104 304 23931 | Rear cover assy | d | 29PT8419/69R | |
| 17f* | 3104 304 23851 | Rear cover assy | e | 29PT8419/79R | |
| 17g* | 3104 328 08471 | Rear cover assy | f | 29PT8419/83R | |
| 17h* | 3139 178 82281 | Top Control assy | g | 27PT8419/17 | |
| 18 | 3139 178 82271 | Top Control assy | h | 29PT8419/61R | |
| 18h* | 3139 178 82281 | Top Control assy | i | 29PT8419/71R | |
| 18i* | 3139 178 82271 | Top Control assy | j | 29PT8419/77 | |
| 18j* | 3139 178 82271 | Top Control assy | k | 29PT8419/78 | |
| 18kl* | 3139 178 82271 | Top Control assy | l | | |

STYLING 304

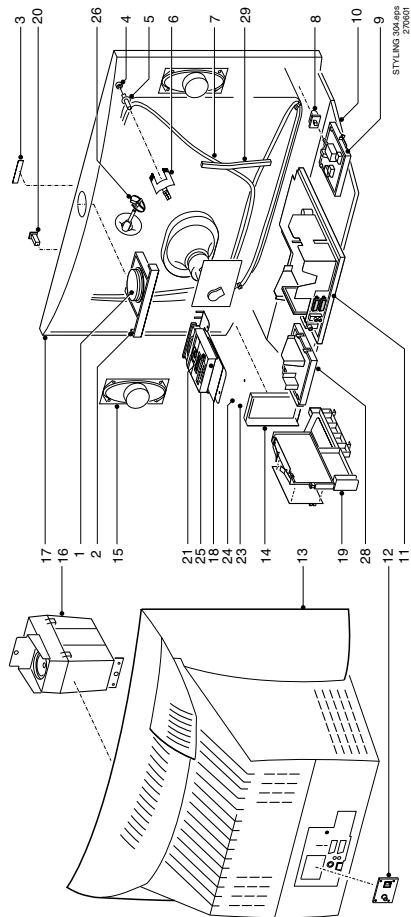
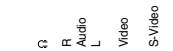
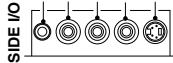
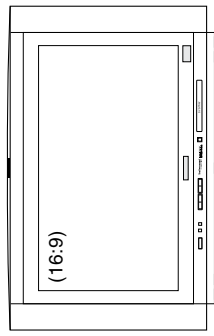

1	3139 137 66921	Top control button	25	3111 254 24921	DVD reader bracket
2	3139 124 33941	Top control bracket	26	4822 532 13136	EHT spacer
3	4822 454 13455	Wordmark	27b*	3139 124 34031	Dolby interface back plate
3b*	3111 250 00731	Wordmark PHILIPS	28b*	3139 124 33151	Dolby prologic bracket
5	4822 505 11195	CRT fixing screw (=310430877012?)	29	4822 404 31341	Coil clamp (=310430415291?)
6	4822 403 70906	Degaussing coil bracket		4822 404 31291	Mains cord relief
7	2422 549 44621	Degaussing coil 28"		3139 124 33811	Light guide
8	3139 124 33801	Mains knob		9301 805 90301	Picture tube 28" W66ERF001X013
9	3139 124 32521	Front interface bracket		4822 321 11139	Mains cord
11	3139 124 32542	Chassis tray		4822 321 11493	Mains cord UK
12	3139 124 33361	SSB bracket	a*	3139 124 35291	Mains harmonic bracket
13a*	3111 257 56701	Rear cover		3111 257 56731	F/O DVD MODULE INTERFACE A10
13b*	3111 257 57531	Rear cover	b*	3111 257 57581	F/O DVD/DPL MOD INTERFACE A10
13c*	3111 257 57451	Rear cover	a*	3111 257 56721	F/O DVD LOADER A10
14	3139 124 31651	Side I/O bracket	b*	3111 257 57741	F/O DVD/DPL LOADER A10
15	2422 264 00377	Loudspeaker 8Ω 10W	a*	3111 257 56712	F/O DOOR DVD 28RF A10
16	3139 128 76372	Subwoofer	b*	3111 257 56712	F/O DOOR DVD 28RF A10
17a*	3111 257 56691	Cabinet	a*	28PW6816	
17b*	3111 257 57521	Cabinet	b	28PW6826	
17c*	3111 257 57441	Cabinet	c	28PW6526	
18	3139 121 27061	DVD top shielding			
19	3139 124 33571	DVD interface bracket			
20	3139 137 91461	DVD eject knob			
21ab*	3111 257 56712	DVD door			
22	3111 254 25181	DVD loader bracket			
23	3111 251 20341	DVD bottom shielding			
24	3111 254 25191	DVD stopper			

STYLING 308

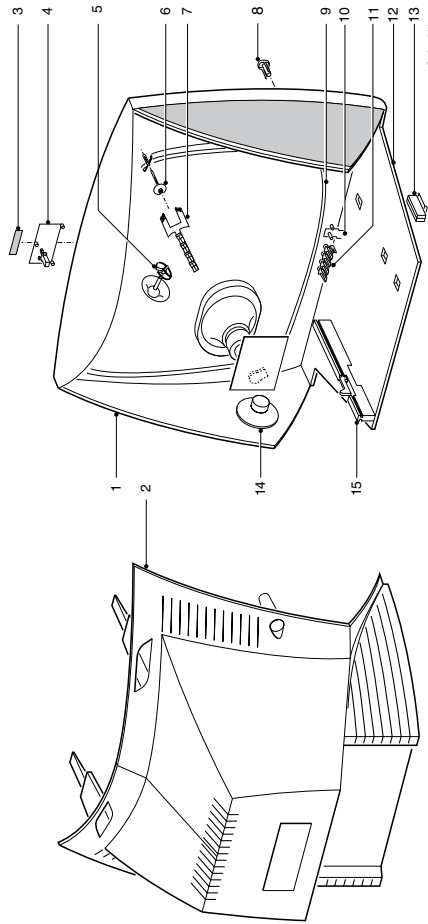
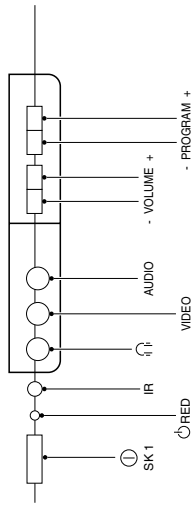
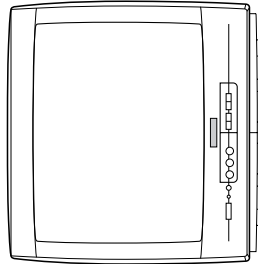

1	3139 137 83691	Cabinet (xxB) Turquoise	8	3139 137 79221	Mains knob
1	3139 137 83711	Cabinet (xxA) Amber	9	2422 549 44446	Degaussing coil
1	3139 137 91241	Cabinet (xxV) Amethyst	10	3139 124 34051	Light guide
1	3139 137 91251	Cabinet (xxG) Aquamarine	11	3139 137 79231	Control knob
1	3139 137 83721	Cabinet (xxP) Pearl	12	3139 124 34111	Bottom plate (VO)
1	3139 137 83701	Cabinet (xxS) Silver Shadow	13	4822 404 31291	Mains cord relief
1b*	3111 257 58441	Cabinet Silver Chrome	14	2422 264 00412	Loudspeaker 8Ω 10W
2	3139 137 91221	Rear Cover (xxB) Turquoise	15	3139 124 34091	Chassis guide (VO)
2	3139 137 91201	Rear Cover (xxA) Amber		4822 321 11499	Mains cord EU
2	3139 137 91231	Rear Cover (xxV) Amethyst		4822 321 11493	Mains cord UK
2	3139 137 91231	Rear Cover (xxG)		3111 257 56161	Rod antenna (01x, 58x)
2	3139 137 91211	Aquamarine		4822 303 91283	Aerial (05x)
2	3139 137 91211	Rear Cover (xxP) Pearl		9301 862 00313	Picture tube A34EAC11X113
2	3139 137 91191	Rear Cover (xxS) Silver Shadow	*a	14PT1686	
2b*	3139 138 18151	Rear Cover Silver Chrome	*b	14PT2002	
3	not applicable				
4	3139 137 85461	Door (xxA) Turquoise			
4	3139 137 85481	Door (xxB) Amber			
4	3139 137 91181	Door (xxV) Amethyst			
4	3139 137 91171	Door (xxG) Aquamarine			
4b*	3139 138 18171	Door Silver Chrome			
4	3139 137 85471	Door (xxP) Pearl			
4	3139 137 85451	Door (xxS) Silver Shadow			
5	4822 401 11765	Coil & THT clamp			
6	4822 502 30739	CRT Fixing screw			
7	4822 404 31325	Degaussing coil bracket			

STYLING 311

FRONT + TOP CONTROL

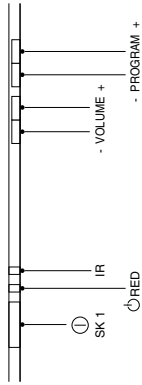

SIDE I/O

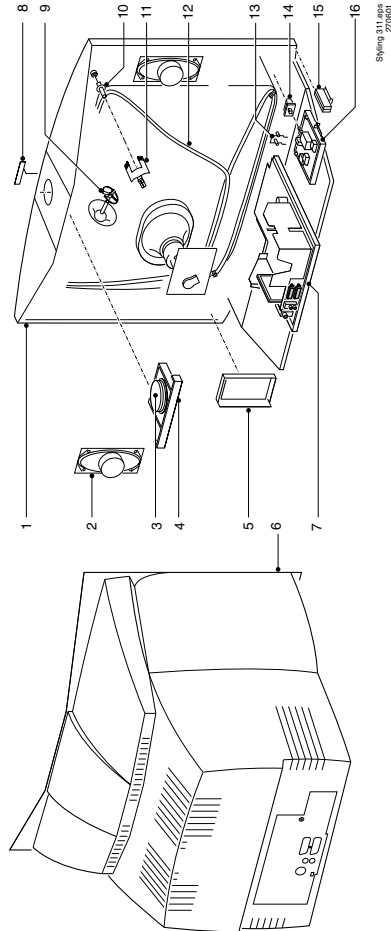
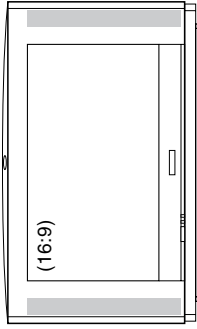
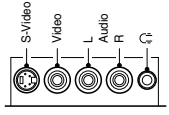

1	3111 257 56911	Cabinet
2	2422 264 00409	Loudspeaker 8Ω 5W
3	3139 137 66921	Top control button
3d*		Top control button
4	3139 124 30381	Top control bracket
4d*		Top control bracket
5	3139 124 37661	Side AV bracket
6	3139 124 35241	Rear cover
7	3139 124 33541	Chassis tray
8	4822 454 13455	Wordmark Philips
9	4822 401 11765	EHT and degaussing coil clamp
10	4822 502 14602	CRT fixing screw
11	4822 403 70906	Degaussing coil bracket
12	4822 157 11758	Degaussing coil 28"
13	3139 124 31631	Light guide
14	3139 124 32511	Mains knob
14	3139 124 33011	Mains knob shaft
15	4822 404 31291	Mains cord relief
16bc*	3139 124 32521	Front interface bracket
ac*	4822 321 11499	Mains cord EU
b*	4822 321 11493	Mains cord UK ((05./25)
	4822 131 11345	Picture tube W66ECK001X14

*a 28FW6006/01
 *b 28FW6006/05
 *c 28PW6006/58
 *d 28PW6106/05

STYLING 321

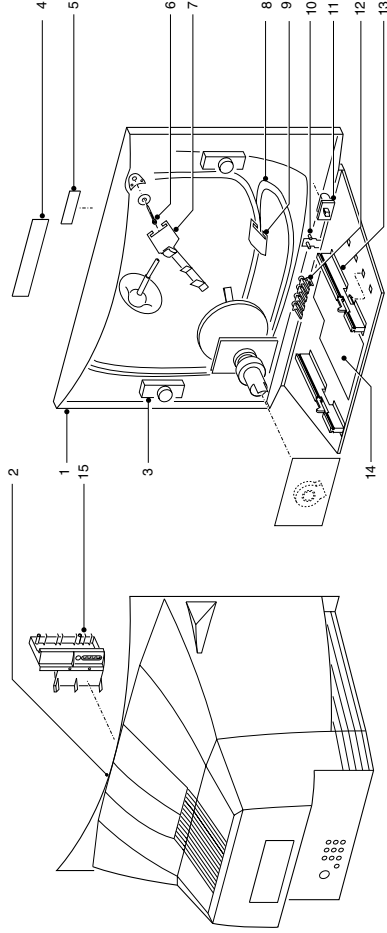
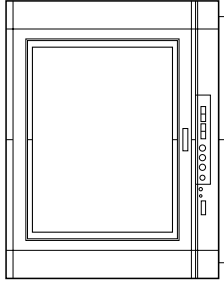
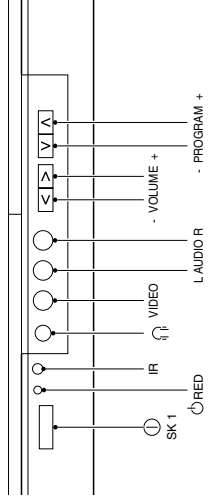

1	313913779011	Cabinet
2	313912438061	Rear cover
3	242226400419	Loudspeaker 16Ω 5W
4b*	313913783961	Cinch door
5	313912001451	Wordmark 14"
6	313912041141	CRT fixing screw
7	313912421802	Coil clamp
8	313912823151	Degaussing coil 15" multi volt
9	313912410113	Corner coil bracket
10	313912434321	Light guide
11	313913779101	Mains knob
12	313913779111	Control knob
13b*	313912434092	Chassis guide (VO)
14b*	313912434361	Bottom plate (VO)
15	Not applicable	
	932216343682	Picture tube 15"
	A36GDT351X01	
	15PT2202.	
	15PT2301, 15PT2302	

*a
 *b

STYLING 326

FRONT + TOP CONTROL

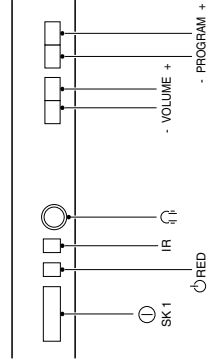

SIDE I/O

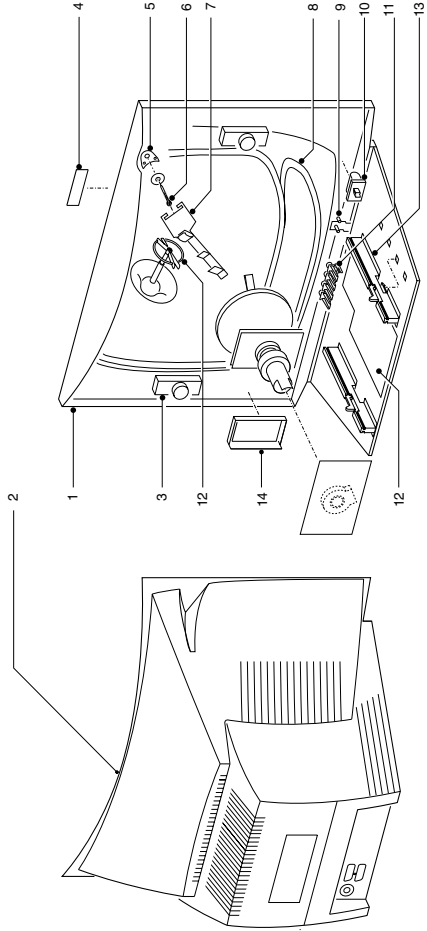
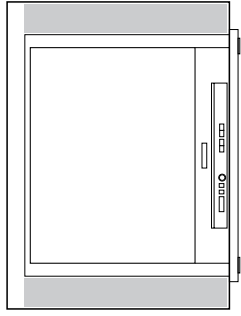
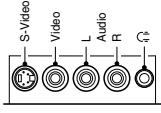

Styling 326, WP
29971

1a*	3139 138 15311	Cabinet 25"	11c*	3139 137 94241	Control knob
1b*	3139 137 79441	Cabinet 25"	12ab*	4822 532 61201	EHT spacer
1c*	3139 137 73671	Cabinet 25"	12c*	4822 401 11765	EHT & degaussing coil clamp
2a*	3139 124 41081	Rear cover 25"	13	4822 463 11226	Chassis guide (VO)
2b*	3139 124 37391	Rear cover 25"	14ab*	3139 124 39541	Side-AV bracket(HP+3AV)
2c*	3139 137 80621	Rear cover 25"	14c*	3139 124 39111	Side AV bracket
3ab*	2422 264 00444	Loudspeaker 8Ω 10W		9322 163 87682	Picture tube 25"
3c*	2422 264 00411	Loudspeaker 16Ω 5W			A59QDF891X001
4ab*	3141 050 00161	Wordmark Philips	*a	25PT2252	
4c*	Not applicable		*b	25HT2212	
5ab*	Not applicable		*c	25RFL160	
5c*	3139 124 23861	Tube spacer			
6	4822 505 11195	CRT fixing screw			
7	4822 404 31434	Degaussing coil bracket			
8ab*	4822 157 11537	Degaussing coil 25"			
8c*	3139 128 76341	Degaussing coil 25"			
9	3139 124 32221	Light guide			
10ab*	3139 124 36331	Mains knob			
10c*	3139 137 94231	Mains knob			
11ab*	3139 124 36311	Control knob			

STYLING 328

FRONT + TOP CONTROL

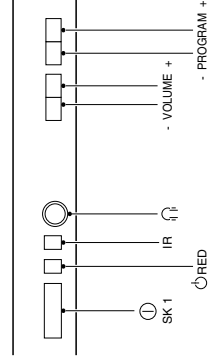

SIDE I/O

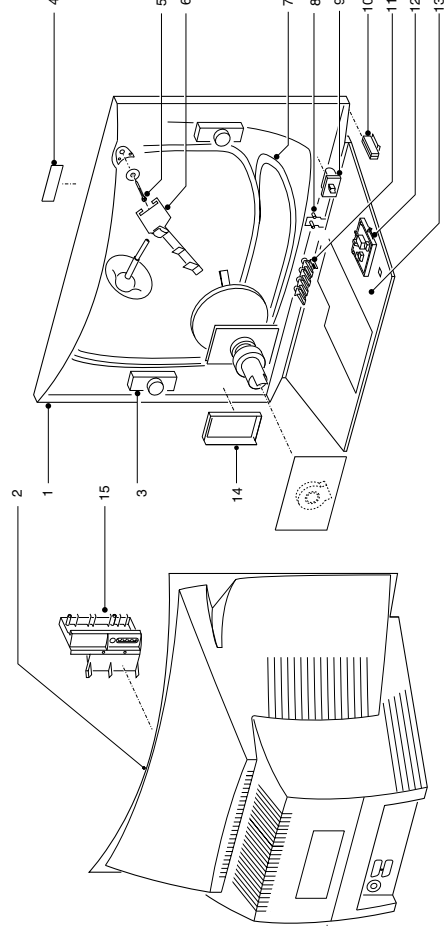
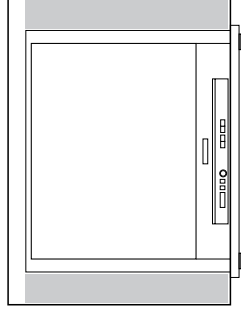
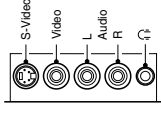

Styling 328, WP
29971

1a*	3139 137 87451	Cabinet 29"
1b*	3139 138 15851	Cabinet 29"
1c*	3139 138 15411	Cabinet 29"
2	3139 124 37231	Rear cover
3	2422 264 00442	Loudspeaker 8Ω 5W
4	3141 050 00161	Wordmark PHILIPS
5	3104 308 77012	CRT fixing screw
6	3139 124 31122	Degaussing coil bracket
7	3139 128 23781	Degaussing coil 29" full range
8	3139 124 30411	Light guide
9	3139 124 36331	Mains knob
10	3122 224 04823	Mains cord relief
11	3139 124 36311	Control knob
12	3139 124 33461	Front interface bracket
13	3139 124 33531	Chassis tray
14	3139 124 33611	Side AV bracket
15	Not applicable	
a*	9322 142 09682	Picture tube 29"
bc*	9322 173 75682	Picture tube 29"
		A68OCP891X001
		A68OCP893X001
*a	29PT2252	
*b	29PT2252/71R	
*c	29PT2252/97R	

STYLING 329

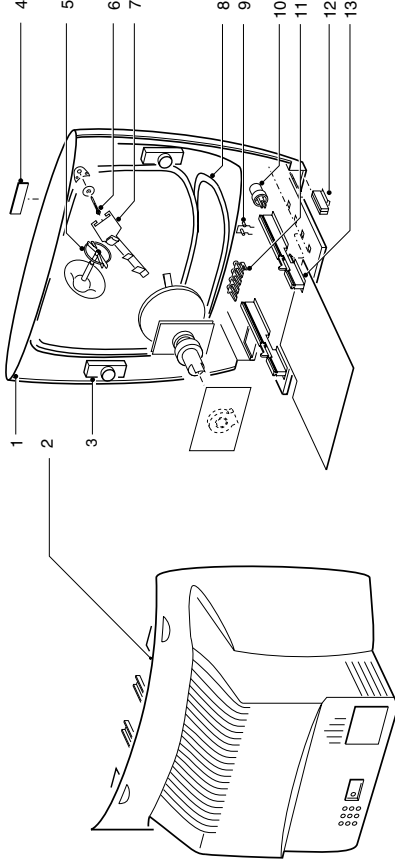
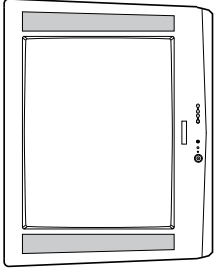
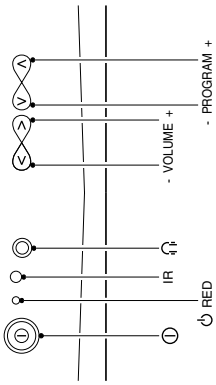

Styling 329.eps
040701

1	3139 137 78821	Cabinet 29"
2	3139 124 35131	Rear cover 29"
3	2422 264 00404	Loudspeaker 8Ω 6W
4	3139 120 01361	Wordmark (grey)
5	4822 532 61201	EHT Spacer
6	4822 505 11195	CRT fixing screw
7	4822 492 71627	Degaussing coil bracket
8	4822 157 11549	Degaussing coil 29" Multi-volt
8	4822 157 11551	Degaussing coil 29"
8	4822 157 11549	Single-volt (.../79F)
8	4822 157 11549	Degaussing coil 29" multi volt (.../71H)
9	4822 380 10251	Light guide
10a*	4822 410 11766	Mains knob
10b*	3139 137 80321	Mains knob
11a*	4822 410 11765	Control knob
11b*	3139 137 80311	Control knob
12a*	4822 404 31363	Mains cord relief
12b*	3122 224 04623	Mains cord relief
13	4822 463 11225	Chassis guide (HB)
13	4822 463 11226	Chassis guide (VO)
	3139 128 75211	Mains cord
	3139 128 75230	Mains cord (.../79F)
	4822 131 20628	Picture tube 29"
		A68AJB82X01

a* 29FT2152
b* 29FT2152/71R

STYLING 332

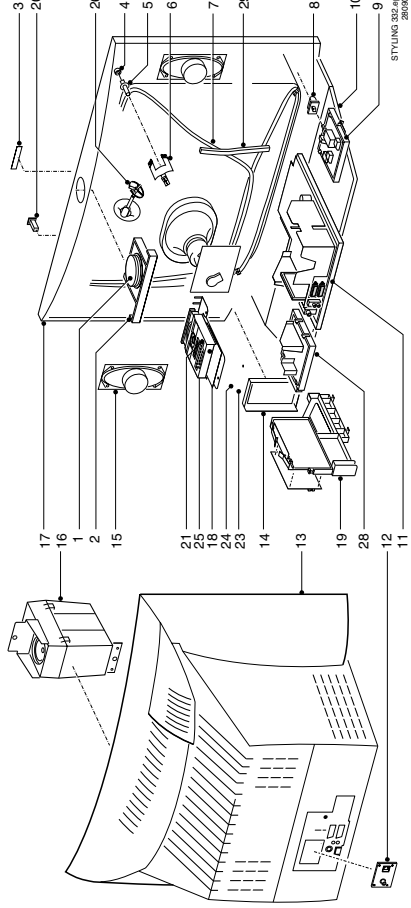
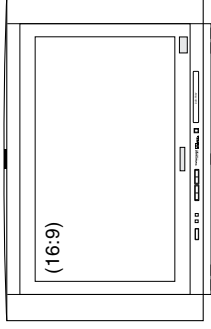
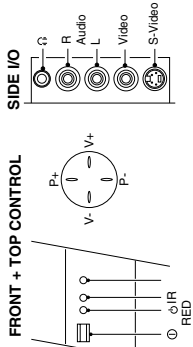

STYLING 332.eps
02041

1	313913766921	Top control button
2	313912433941	Top control bracket
3	311125000811	Wordmark Philips
5	311125040031	CRT fixing screw
6	310430414713	Degaussing coil bracket
7	2422 549 44244	Degaussing coil 32"
8	3139 124 33801	Mains knob
9	3139 124 32521	Front interface bracket
11	3139 124 32542	Chassis tray
12	3139 124 33361	SSB bracket
13a*	3111 257 57471	Rear cover
13b*	3139 124 38801	Rear cover
14	3139 124 31651	Side I/O bracket
15	242225720547	Loudspeaker 8Ω 15W
16	313912876372	Subwoofer
17a*	3111 257 57461	Cabinet 32" DPL
17b*	3139 137 99511	Cabinet 32" DVD/DPL
18	3139 121 27061	DVD top shielding
19	3139 124 33572	DVD interface bracket
20	3139 124 33561	DVD eject knob
21ab*	3139 137 99951	DVD door
22	3111 254 25181	DVD loader bracket
23	3111 251 20341	DVD bottom shielding
24	3111 254 25191	DVD stopper
25	3111 254 24921	DVD reader bracket
	311125423481	EHT & degaussing coil clamp
	313912433152	Dolby prologic bracket
	310430415291	Degaussing coil clamp
	310430414414	Corner coil bracket
	310430414765	Mains cord relief
	310430875701	VO insulator ring
	482200950481	Mains cord UK
	482200950501	Mains cord EU
	930180090314	Picture tube 32"
	W76ERF001X013	Picture tube 32"
	3139 124 33811	Light guide
	3139 124 35291	Mains harmonic bracket
	32PW6526	
	32PW6826	

*a
*b

STYLING 334

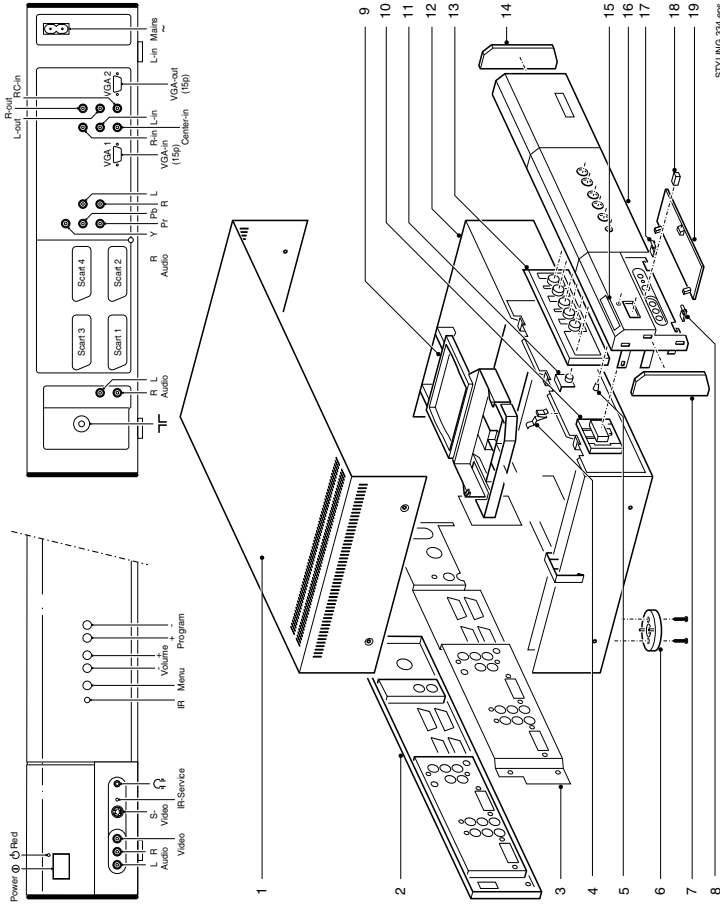

1	3122 128 13411	Top cover
2	3122 128 13741	Connector plate
3	3122 121 35821	Shielding
4	3122 121 67141	Spring
5	3122 124 35861	Light guide
6	4822 462 11187	Foot
7	3122 128 13711	Side panel left
8	4822 417 11384	Hinge left
9	3122 124 35771	Bracket for FBX/DW
10	3122 128 13441	Mains knob
11	3122 124 35881	Window
12	3122 128 13451	Frame assy
13	3122 128 13731	Knob frame
14	3122 128 13721	Side panel right
15	3139 247 51831	Wordmark
16	3122 128 13421	Front
17	4822 417 11385	Hinge right
18	4822 417 50289	Lock
19	3122 128 13431	Door

STYLING 334-466
260001

STYLING 335

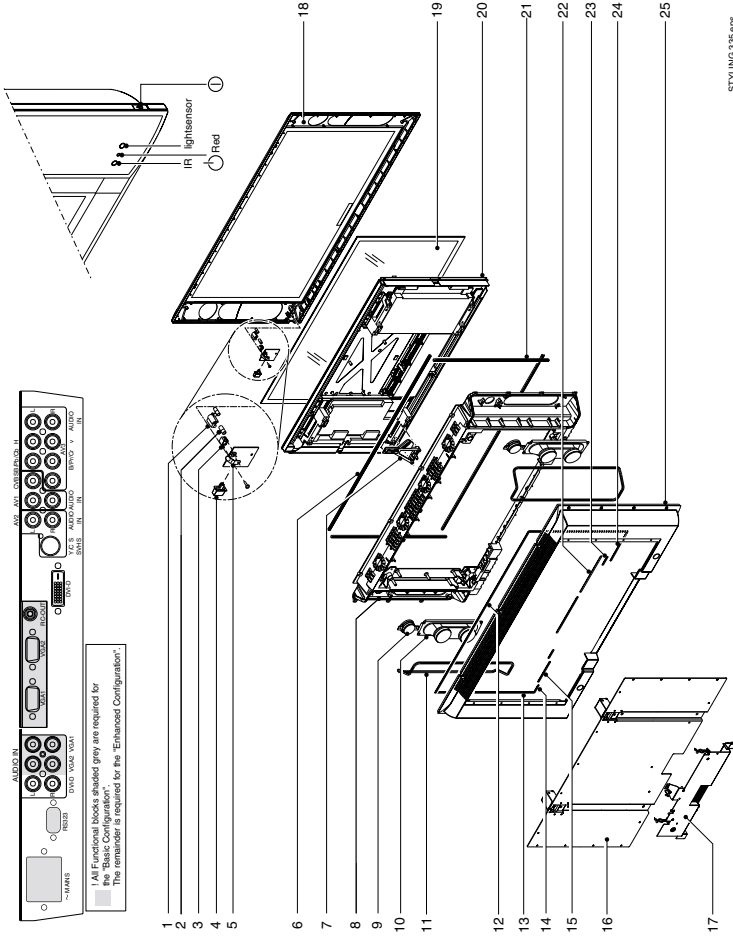

1	3122 124 36071	Lens
2	3122 124 36271	Light guide
3	3122 124 36081	Day light filter
4	3122 128 13901	On/off knob
5	3122 121 67251	Lead switch spring
6	3122 358 76201	EMC shielding foam long
7	3122 124 36171	Cable track
8	3122 128 13911	Shielding frame
9	2422 264 00432	Tweeter
10	2422 264 00433	Loudspeaker twin
11	3122 358 76221	Loudspeaker foam
12	3122 358 76151	EMC shielding foam top
13	3122 357 76161	EMC shielding foam L+R
14	3122 358 76251	EMC shielding foam bottom L1
15	3122 358 76261	EMC shielding foam bottom L2
16	3122 128 13951	Metal back plate
17	3122 128 13681	Connector plate
17b*	3122 128 13695	Connector plate
18a*	3122 357 21201	Front assy -/01S
18ab*	3122 357 21361	Front assy -/69S
18b*	3122 357 21391	Front assy -/17S
19	3122 124 90781	Glassplate
20	9322 178 04682	Display FPF32C106128UA-52
21	3122 358 76211	EMC shielding foam short
22	3122 358 76191	EMC shielding foam bottom 3
23	3122 358 76181	EMC shielding foam bottom 2
24	3122 358 76171	EMC shielding foam bottom 1
25	3122 128 13871	Back display assy
	4622 007 51971	Mains cord EU
	2422 070 98107	Mains cord UK
	2422 070 98105	Mains cord China
	2422 070 98106	Mains cord Aus/NZ
	3122 358 75802	Mains cord US
	9097 210 04055	Coloured frame Champagne
	9097 210 04056	Coloured frame Blue
	9097 210 04057	Coloured frame Green
	9097 210 04058	Coloured frame Rouge
	9097 210 04059	Coloured frame Unpainted
	32FD9944	
	32FD9954	

STYLING 335-466
011001

STYLING 336

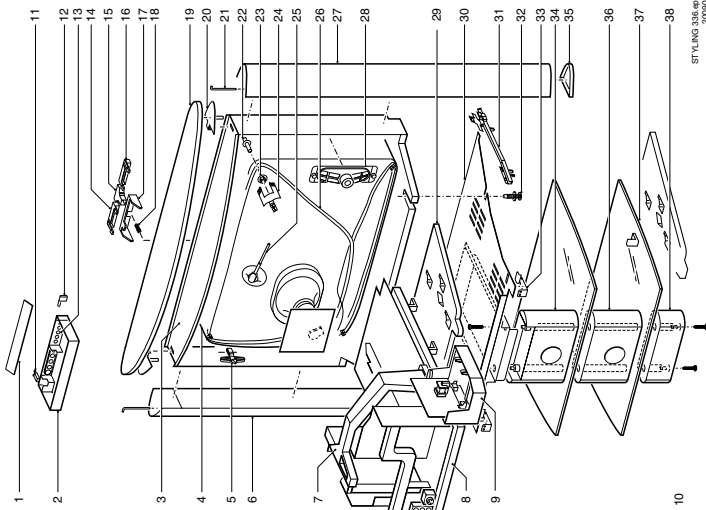
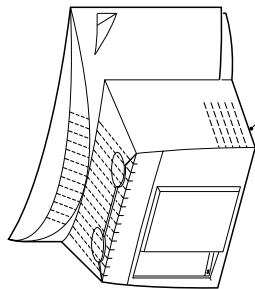
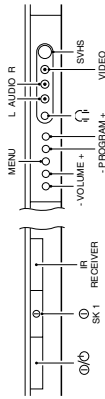
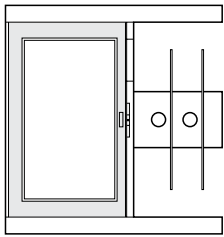

STYLING 336 REF. 203011

1	3104 307 96921	Door	3104 304 22012	Bottom plate
2	3104 304 22621	Bracket front controls	9965 000 07349	Top plate stand
3	3104 307 97791	Cover aluminum column right	4822 402 11183	Mains cord guide
4	3104 328 17201	Cabinet assy 32PW9556	3104 308 78041	Screw for stand assy
5	3104 328 17212	Cabinet assy 32PW9566	9965 000 07348	Steel clip
6	3104 328 17222	Cabinet assy 32PW9576	9965 000 07391	Back column part 1 shelf
7	9301 880 70314	CRT W76ERF042X044	9965 000 07392	Back column part 2 shelf
8	3104 307 96931	Aluminum column right	3104 304 22691	Foot right
9	3104 304 21114	LOT support bracket	3104 304 22701	Foot left
10	3104 304 23001	Frame for LSP	9965 000 07390	Back column part 1 shelf
11	3104 304 23041	Bracket for DAF/DC shift panel	9965 000 07393	Back column part 2 shelf
12	3104 307 96891	Rear cover 32PW9556	9965 000 07389	Glass plate
13	3104 307 96901	Rear cover 32PW9566	9965 000 07394	Back column part 2 shelf
14	3104 307 98231	Rear cover 32PW9576	3104 308 78021	Rear leg stand assy
15	3104 308 70381	Locking unit	3104 308 78031	Rear leg stand assy for -/05/19
16	3104 308 78011	Damped hinge	4622 009 50772	Mains cord
17	3104 304 22661	Knob frame controls	4622 009 50782	Mains cord for -/05/67
18	3104 304 22671	Window right	3104 328 14471	Mains cord for -/79
19	3104 307 96911	Mains knob	3104 300 12171	Wordmark 32PW9556
20	3104 307 96981	Window left	3104 300 12181	Wordmark 32PW9566
21	3104 304 22601	Support for mains switch	3104 300 12211	Wordmark 32PW9576
22	Not present	Spring	3104 308 77981	Focus cable
23	3104 304 90371	Glass plate 32PW9556	4822 157 11825	Rotation coil
24	3104 304 90381	Glass plate 32PW9566	3104 207 09561	Remote control RC203101B
25	3104 304 90391	Glass plate 32PW9576	3104 300 12121	Matchline emblem
26	3104 307 97801	Cover aluminum column left	3104 300 20181	Adapter EURO to Cinch/S-VHS for -/57/69/79
27	3104 301 62111	Pin fix aluminum columns	3104 300 20191	Adapter EURO to 3 x Cinch for -/57/69/79
28	4822 502 21359	CRT screw		
29	4822 404 31294	CRT fixation VP19100		
30	4822 404 31289	Bracket fix degaussing coil (2x)		
31	4822 403 03906	Bracket fix degaussing coil (2x)		
32	3104 311 03272	EHT cable		
33	2422 549 44244	Degaussing coil		
34	3104 307 96941	Aluminum column left		
35	2422 264 00386	Loudspeaker		

STYLING 341

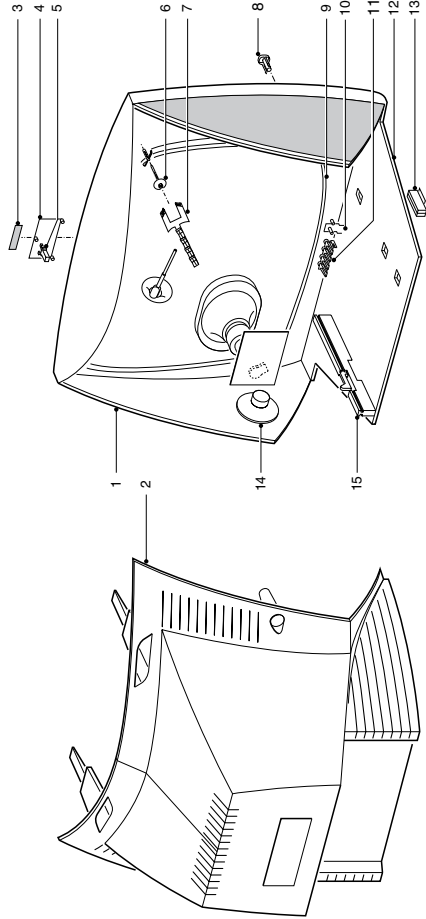
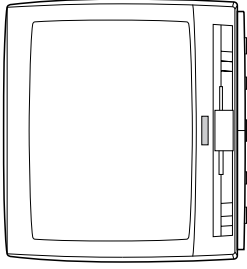
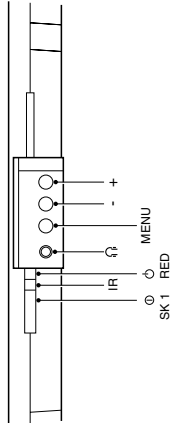

STYLING 341 REF. 18331

1a*	3111 257 56651	Cabinet (HP+3AV)
1b*	3111 257 58451	Cabinet (HP+3AV, silver shadow)
2a*	3111 257 58511	Rear cover (mid grey)
2b*	3111 257 58521	Rear cover (warm grey)
3a*	3111 250 00051	Wordmark Philips (blue silver back)
3b*	3111 250 00741	Wordmark Philips
4a*	3139 137 85081	Door
4b*	3139 138 18041	Door
5	3139 120 41391	CRT fixing screw
6	4822 404 30945	Corner coil bracket
6	4822 401 11765	Coil & THT clampacket
7	3139 137 76451	Mains knob
8	2422 549 44669	Degaussing coil 21"
9	3139 124 25551	Cinch cover
10	3139 124 32301	Light guide
11	3139 137 76461	Control knob
12	3139 124 33291	Plate VO
13	4822 404 31291	Main cord holder
14	2422 264 00398	Speaker 16Ω 5W
15	3139 124 36232	Chassis guide (VO)
	4822 131 11105	Picture Tube 21" A51EAL155X47
	4822 321 11499	Mains cord EU
	4822 321 11493	Mains cord UK

*a 21PT4406
*b 21PT4416

STYLING 343

FRONT + TOP CONTROL

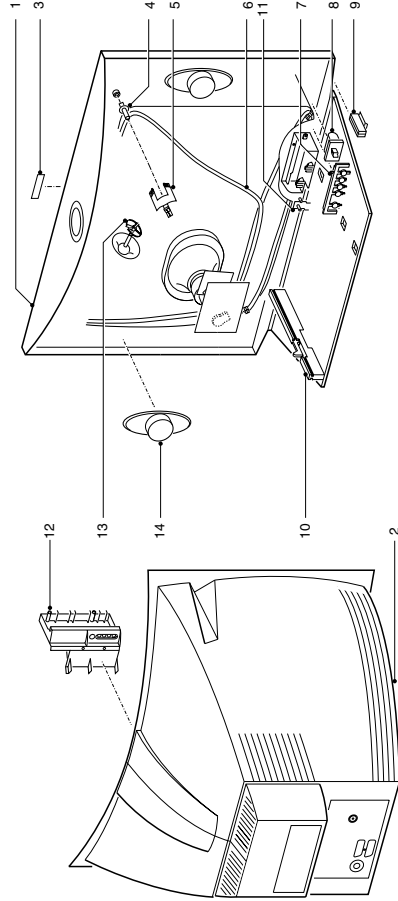
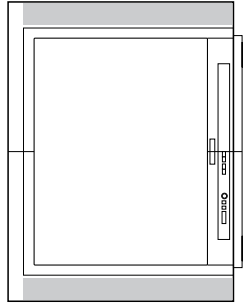
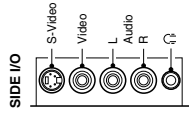
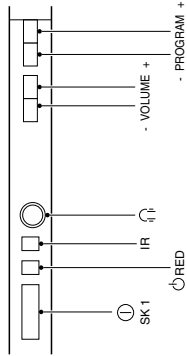

Styling 343 parts list 181201

1	3139 137 79801	Cabinet 25"
2	3139 124 35671	Rear cover
3	3111 250 00831	Wordmark (red silver)
4	4822 505 11195	CRT fixing screw
5	4822 401 11765	Degaussing coil bracket
6	2422 549 44253	Degaussing coil 25"
7	3139 137 93871	Control knob
8	3139 137 93861	Mains knob
9	4822 404 31291	Mains cord relief
10	3139 124 30881	Chassis guide
11	3139 124 35681	Light guide
12	3139 124 37661	Slide AV bracket
13	4822 401 11765	Coil & EHT clamp
14	2422 264 00409	Loudspeaker 8Ω 5W
a*	4822 131 11184	Picture tube A59EAK071X11
b*	9322 147 09682	Picture tube A59EMZ43X07
c*	4822 131 20568	Picture tube A59EAK562X11
	4822 321 11499	Mains cord EU
	4822 321 11493	Mains cord UK
	3111 257 71441	Stand (silver) UK only
*a	25PT4457/01/05	
*b	25PT4457/21	
*c	25PT5107/01/58	

STYLING 344

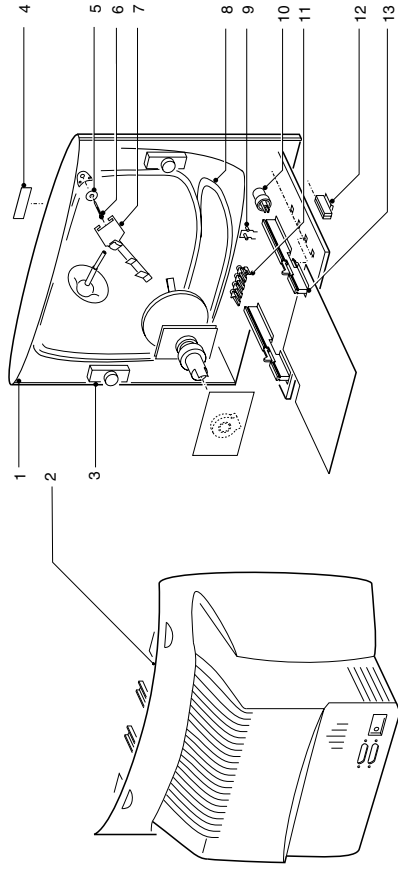
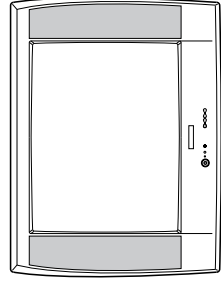
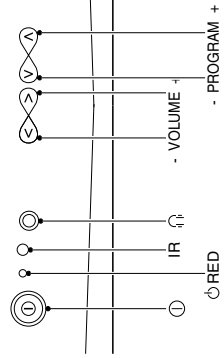

STYLING 344 parts list 181201

1	313913798001	Cabinet
2	313912438761	Rear cover
3	2422 264 00401	Loudspeaker 16Ω 5W
4a*	311125000271	Wordmark Aristona
4b*	3111 250 00261	Wordmark SBR
4c*	31222000232	Wordmark Radiola
5	Not applicable	CRT fixing screw
6	4822 505 11195	Control knob
7	482240370906	Corner coil bracket
7	482240111765	Coil & THT clamp
8	4822 157 11762	Degaussing coil 28"
9	4822 380 10251	Light guide
10	3139 124 30581	Mains knob
11	4822 410 12433	Control knob
12	4822 404 31363	Mains cord relief
13	3139 124 30871	Chassis guide right (HB)
13	3139 124 30881	Chassis guide left (VO)
	4822 321 11493	Mains cord UK
	4822 321 11499	Mains cord EU
	4822 402 10844	PCB relief bracket
	4822 403 70906	Corner coil bracket
	4822 131 11045	Picture tube 28" A66EAK071X11
*a	70TA4416/03	
*b	70TA4416/11	
*c	70TA4416/18	

STYLING 345

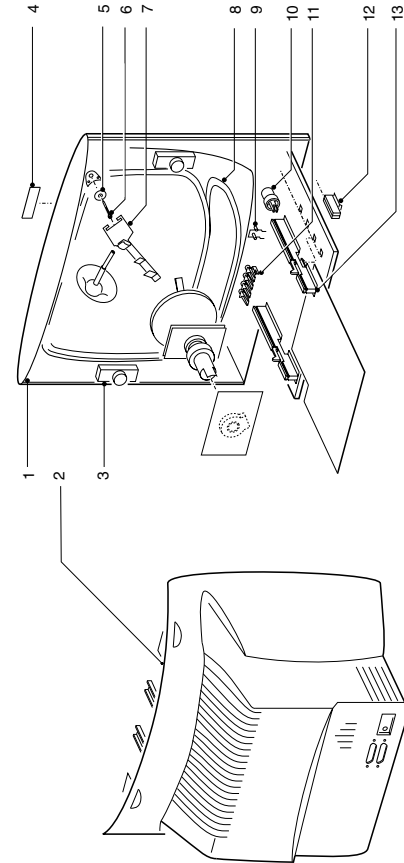
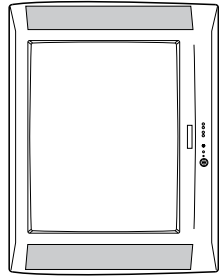
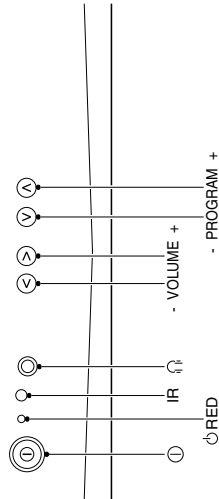

Styling 345/eps
181201

1	3111 257 58101	Cabinet 28"
2	3139 124 41321	Rear cover 28"
3	2422 264 00401	Loudspeaker 16Ω 5W
4	3111 250 00731	Wordmark PHILIPS 28"
5	Not applicable	
6	4822 505 11195	CRT fixing screw 28"
7	4822 401 11765	Degaussing coil bracket
8	4822 403 70906	Corner coil bracket
9	4822 157 11762	Degaussing coil 28"
10	4822 380 10251	Light guide
11	3139 124 30581	Mains knob
12	3139 124 27071	Control knob
13	3122 224 04623	Mains cord relief
13	3139 124 30881	Chassis guide left (VO)
13	3139 124 30871	Chassis guide right (HB)
	4822 131 11045	CRT 28"
	4822 321 11499	A66EK071X11
	4822 321 11499	Mains cord
	4822 321 11493	Mains cord UK
	28PT4426	

STYLING 346

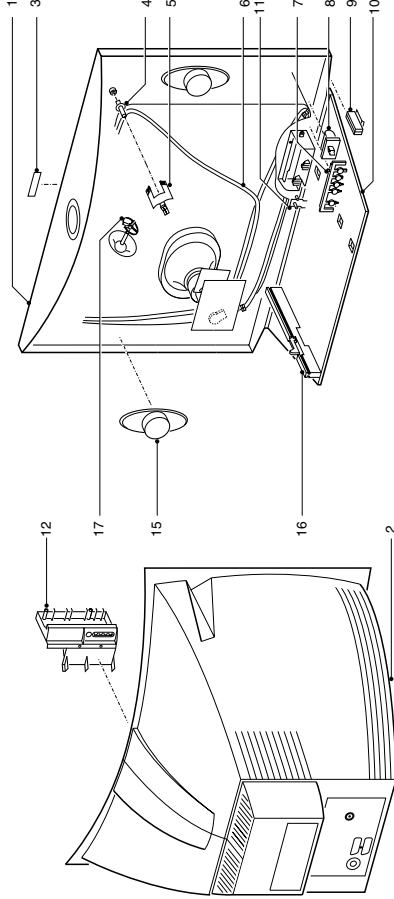
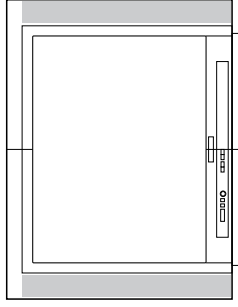
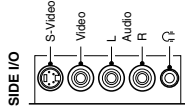
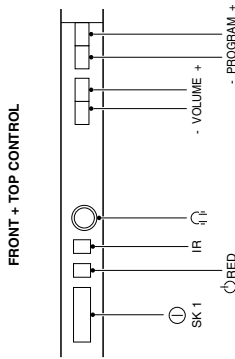

Styling 346/eps
181201

1a*	3139 137 79311	Cabinet 28"
1b*	3139 137 93961	Cabinet 28"
2	3139 138 12361	Rear cover 28"
3a*	3111 250 00831	Wordmark (red silver)
3b*	3111 250 00731	Wordmark Philips
4	4822 505 11195	CRT fixing screw
5	4822 403 70906	Corner coil bracket
5	4822 401 11765	Coil & THT clamp
5	4822 403 70906	Degaussing coil bracket
6	4822 157 11762	Degaussing coil 28"
7	3139 137 90621	Control knob
8	3139 137 90631	Mains knob
9	4822 404 31291	Mains cord relief
10	Not applicable	
11	3139 124 37781	Light guide
12	3139 124 37661	Side AV bracket
13	Not applicable	
14	Not applicable	
15	2422 264 00409	Loudspeaker
16	3139 124 30881	Chassis guide
17	4822 401 11765	Coil & EHT clamp
	3111 257 71441	Stand (silver) UK only
	3139 128 76381	FM aerial
	4822 321 11493	Mains cord UK
	4822 321 11499	Mains cord EU
a*	9301 731 00346	Picture tube A66EK071X21
b*	9301 211 10346	Picture tube A66EK552X21
*a	28PT4457/28PT4657	
*b	28PT5107	

STYLING 347

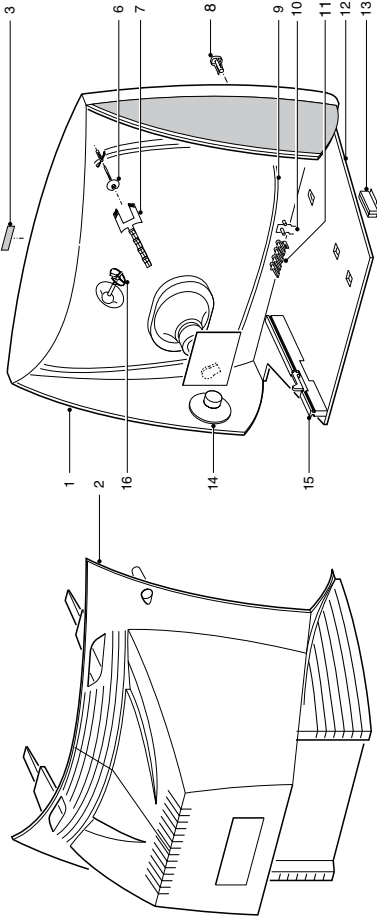
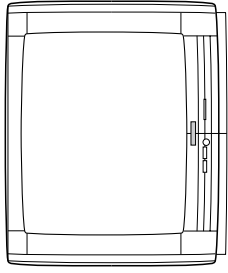
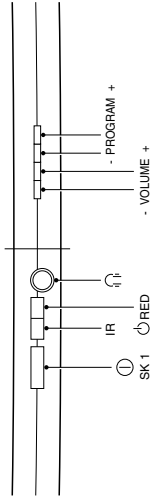

STYLING 347 eps
18/201

1	3139 137 85731	Cabinet 28"
2	3139 124 36241	Rear cover 28"
3	3111 250 00201	Wordmark
4	Not applicable	
5	Not applicable	
6	4822 505 11195	CRT fixing screw
7	4822 403 70906	Degaussing coil bracket
8	3139 137 90651	Mains knob
9	4822 157 11762	Degaussing coil 28"
10	3139 124 37111	Light guide
11	3139 137 90661	Control knob
12	Not applicable	
13	4822 404 31291	Mains cord relief
14	2422 264 00398	Loudspeaker 16Ω 5W
15	3139 124 30881	Chassis guide (VO)
16	4822 401 11765	Coil & EHT clamp
	4822 321 11499	Mains cord EU
	4822 131 11045	Picture tube A66EAK071X11
	9322 147 09662	Picture tube A66EMZ43X07
		(.../21)

28PT4406

STYLING 349

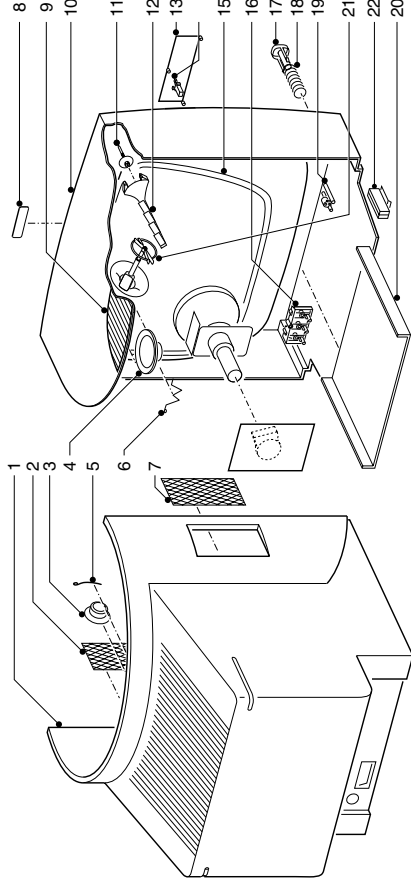
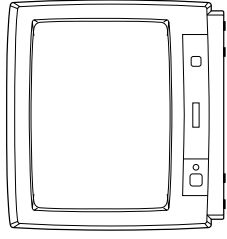
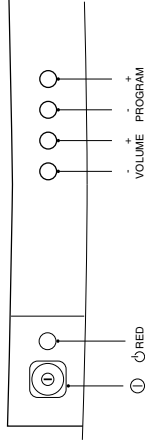

STYLING 349 eps
18/201

1	3111 254 25171	Rear cover
2	Not applicable	
3	Not applicable	
4	3111 254 10061	Loudspeaker grill
4	2422 264 00414	Loudspeaker 8Ω 5W
5	Not applicable	
6	Not applicable	
7	Not applicable	
8	3111 250 00941	Wordmark (silver shadow)
9	Not applicable	
10	3139 137 85581	Cabinet (HP+2AV)
11	4822 502 14508	CRT fixing screw
12	3119 104 18247	Degaussing coil bracket
13	Not applicable	
14	not applicable	
15	2422 549 44843	Degaussing coil 17"
16	3111 254 09921	Control knob
17+18	3111 254 09911	Mains knob
19	4822 380 10281	Light guide
20	4822 463 11126	Chassis guide (HB)
	4822 463 11125	Chassis guide (VO)
	4822 401 11765	Coil & EHT clamp
	4822 466 11463	Mains cord relief
	4822 321 11499	Mains cord EU
	4822 321 11499	Mains cord UK
	3139 128 76381	FM aerial
	9301 835 40301	Picture tube A41EAM40X20
	17PT1666	

STYLING 355

FRONT CONTROL

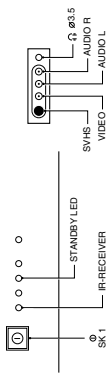

SIDE I/O

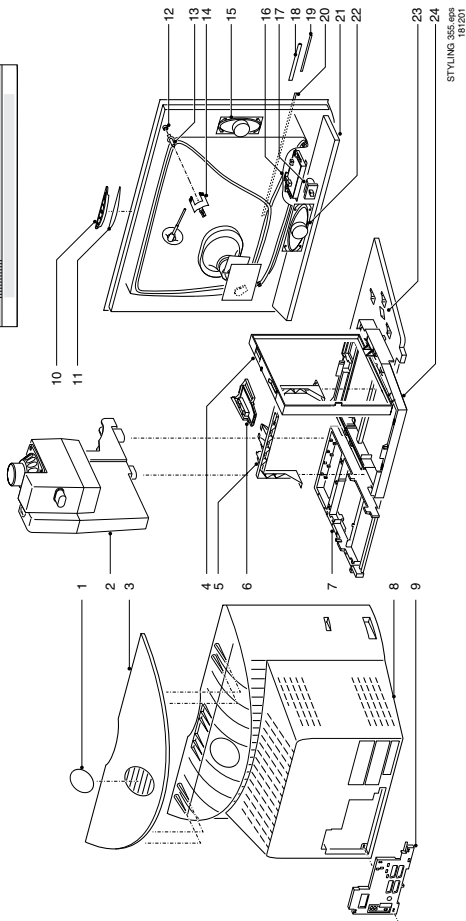
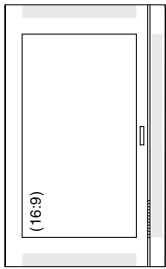

1	3104 304 24021	Cover 28"	21	3104 328 12261	Cabinet 32"
1	3104 307 99141	Cover 32"	21	3104 328 12251	Cabinet 36"
1	3104 304 24011	Cover 36"	22	2422 264 00431	Loudspeaker (1x)
2	4822 445 10634	Subwoofer box	23	3104 304 23491	Bottom plate
3	3104 307 98631	Top cover 28"	24	3104 304 19583	Frame for LSP
3	3104 307 98641	Top cover 32"		3104 300 12121	Matchline emblem
3	3104 307 98651	Top cover 36"		3104 300 12231	Philips emblem 28"
4	3104 304 19652	Frame for supply panel		3104 300 12241	Philips emblem
5	3104 304 20264	LOT support bracket		3104 304 19646	Module support bracket on SSP
6	3104 304 23481	Bracket side I/O		3104 304 21031	Bracket for rotation coil
7	3104 304 22851	Frame for SSP		3104 304 20301	Bracket for DAF panel
8	3104 307 97541	Rear cover 28"		2322 460 91641	DAF potmeter 32"/36"
8	3104 307 97531	Rear cover 32"		2422 549 44621	Degaussing coil 28"
8	3104 307 97521	Rear cover 36"		8204 000 74951	Degaussing coil 32"
9a*	3104 307 98281	Coverplate		2422 549 44242	Degaussing coil 36"
9b*	3104 307 98271	Coverplate		3128 147 13651	Rotation coil
10	3104 307 98241	Keypad assy		3128 138 60651	Picture tube W66ERF041X44
11	3104 304 23431	Bottom top control		9301 852 40306	Picture tube W76EKW10X73
12	4822 404 31294	Insert VP19100		3104 300 50301	Picture tube W66LPX955X
13	4822 505 11195	Picture tube screw 28"		3128 147 13651	Remote control RC2044/01B
13	4822 502 21359	Picture tube screw		4822 321 11448	Mains cord
14	4822 403 70906	Bracket fix deg. coil (4x) 28"		4622 007 51852	Mains cord -/05
14	3104 304 21091	Bracket fix deg. coil (4x)		3104 130 01801	Set surround sound boxes -/12
15	2422 264 00429	Loudspeaker (2x)		3104 130 01811	Set surround sound boxes -/58
16	3104 304 23471	Bracket mains unit		3104 130 01821	Set surround sound boxes -/05
17	3104 307 97621	Mains knob		3104 130 02041	Set surround sound boxes 36PW9607/05
18	3104 304 23461	Light guide		32PW9617, 36PW9607	
19	3104 304 23651	Deco strip left 28"		xxPW9767	
19	3104 304 23621	Deco strip left 32"			
19	3104 304 23591	Deco strip left 36"			
20	3104 304 23661	Deco strip right 28"			
20	3104 304 23631	Deco strip right 32"			
20	3104 304 23601	Deco strip right 36"			
21	3104 328 12271	Cabinet 28"			

*a

*b

STYLING 358

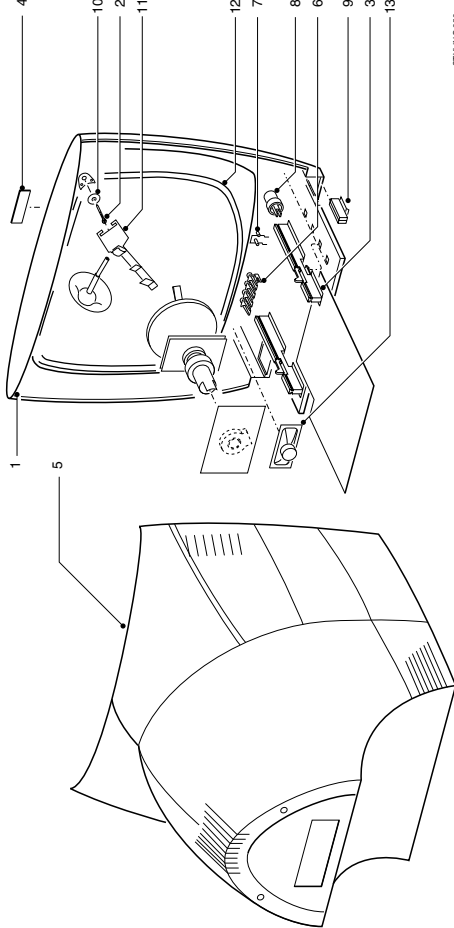
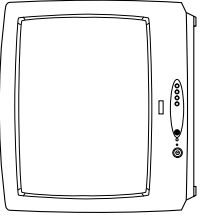
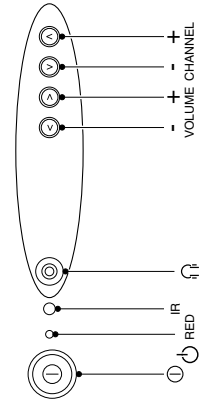

STYLING 358-999
16/201

1	3139 138 16191	Cabinet 20" (HP+FC)
2	3139 124 36261	Rear cover 20"
3	3111 250 00321	Wordmark Aristona (.../03)
3	3111 250 00341	Wordmark SBR (.../11)
4	Not applicable	
5	4822 502 14508	CRT fixation screw
6	3111 254 23481	Coil & THT clamp
7	2422 549 44323	Degaussing coil 20"
8	3139 124 26193	Light guide
9	3139 124 37871	Mains knob
10	3139 124 26182	Control knob
11	4822 466 11453	Mains cord relief
12	4822 463 11125	Chassis guide (VO)
12	4822 463 11126	Chassis guide (HB)
13	2422 264 00399	Loudspeaker 16Ω 4W
	9322 165 88682	Picture tube 20"
	A48CR43X58	A48CR43X58
	4822 321 11493	Mains cord UK
	4822 321 11499	Mains cord EU
	51TA1474	
	51TA1476	

STYLING 359

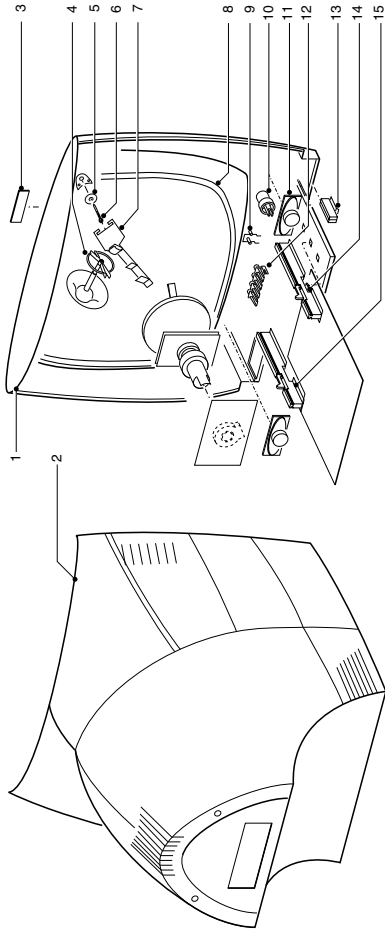
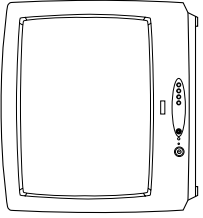
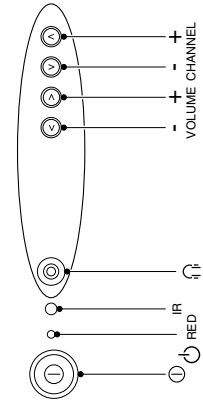

STYLING 359 045
07/832

1	3139 138 16191	Cabinet 20" (HP+FC)
2	3139 124 36261	Rear cover 20"
3	3111 250 00051	Wordmark Philips
4	4822 401 11765	Coil & EHT spacer
5	Not applicable	
6	4822 502 14508	CRT fixing screw
7	4822 404 30839	Degaussing coil bracket
8	2422 549 44323	Degaussing coil 20"
9	3111 257 54841	Light guide
10	3139 124 37871	Mains knob
11	2422 264 00399	Loudspeaker 16Ω 4W
12	3139 124 26182	Control knob
13	4822 466 11453	Mains cord relief
14	4822 463 11126	Chassis guide (HB)
15	4822 463 11125	Chassis guide (VO)
	9322 165 88682	Picture tube 20"
	4822 321 11493	A48ECR43X58
	4822 321 11499	Mains cord UK
	4822 321 11499	Mains cord EU
	20PT1346/01/58	
	20PT1546/01/58	

STYLING 360

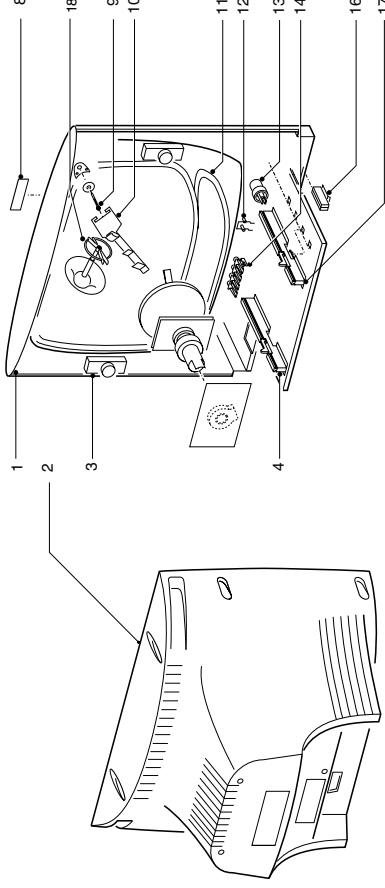
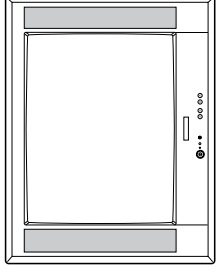
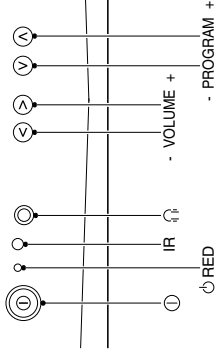

STYLING 360 045
20/832

1a*	3111 257 58301	Cabinet (silver shadow)
1b*	3111 257 58311	Cabinet (light grey)
2a*	3139 124 38741	Rear cover
2b*	3139 124 41881	Rear cover
3	4822 240 10368	Speaker
4	4822 463 11126	Chassis guide (HB)
4	4822 463 11125	Chassis guide (VO)
8a*	3111 250 00741	Wordmark Philips
8b*	3111 250 00321	Wordmark Aristona
9	4822 502 14071	CRT fixing screw
10	4822 404 30945	Degaussing coil bracket
11	2422 549 44669	Degaussing coil 21"
12	4822 380 10281	Light guide
13a*	3139 124 41481	Mains knob
13b*	3139 124 26891	Mains knob
14a*	3139 138 15911	Control knob
14b*	3139 124 41601	Control knob
16	4822 404 31291	Mains cord holder
17	3139 124 23463	Chassis guide (VO)
17	3139 124 23452	Chassis guide (HB)
18	4822 401 11765	Coil EHT clamp
	9301 738 50342	Picture tube A51EAL155X47
	4822 466 11453	Mains cord relief
	4822 321 11499	Mains cord
	4822 321 11493	Mains cord UK
*a	21PT4426	
*b	52TA4416	

STYLING 361

STYLING 362

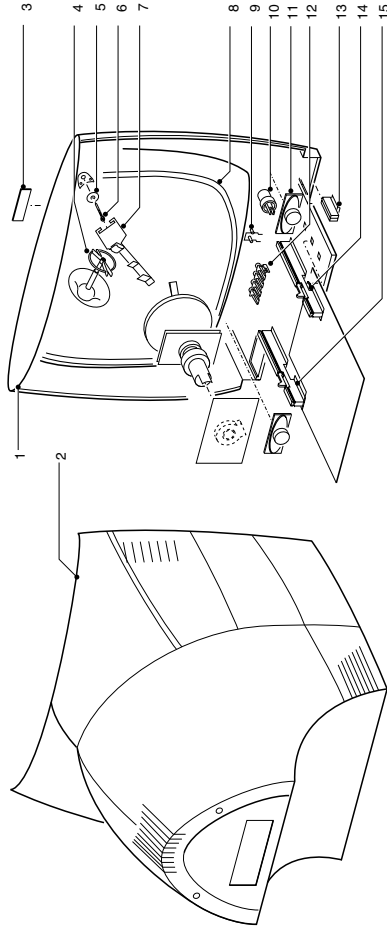
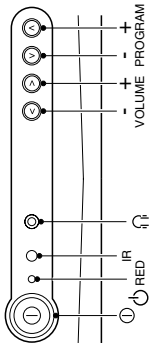
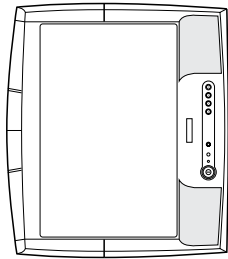

STYLING 361 699
200302

1	3139 138 16181	Cabinet (HP+FC)
2	3139 124 36391	Rear cover (1 SCT)
3	3111 250 00321	Wordmark Aristona (03)
3	3111 250 00341	Wordmark SBR (/11)
4	4822 401 11765	Coil & THT clamp
6	4822 502 14071	CRT fixing screw
7	4822 404 30945	Degaussing coil bracket
8	2422 549 44669	Degaussing coil 21"
9	3139 124 28081	Light guide
10	3139 124 41581	Mains knob
11	2422 264 00401	Loudspeaker 16Ω 5W
12	3139 124 28071	Control knob
13	4822 466 11453	Mains cord relief
14	4822 463 11126	Chassis guide (HB)
15	4822 463 11125	Chassis guide (VO)
	4822 131 11105	Picture tube 21" A51EAL155X47
	4822 321 11493	Mains cord UK
	4822 321 11499	Mains cord EU
	52TA1476/03/11	

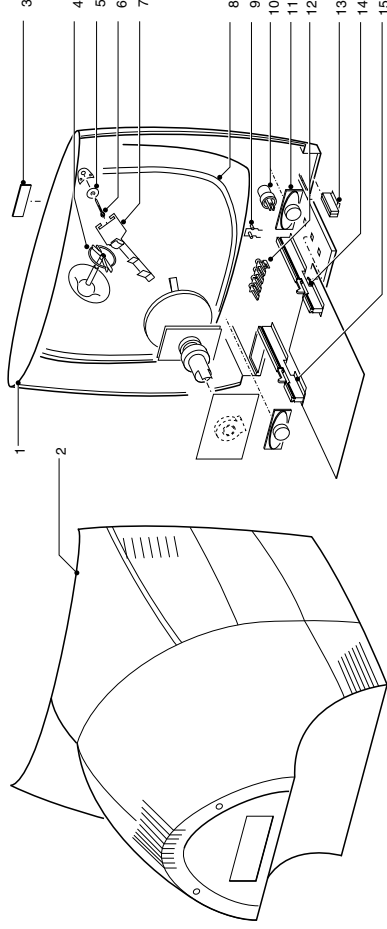
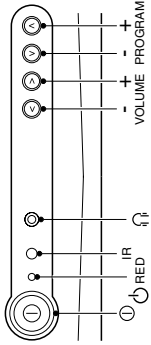
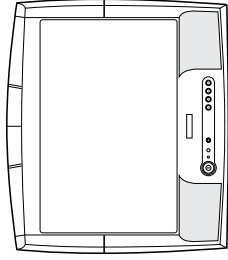

STYLING 362 699
200302

1	3139 138 16181	Cabinet (HP+2AV)
2	3139 124 36391	Rear cover
3	3111 250 00051	Wordmark
4	3111 254 23481	EHT spacer
5		
6	3111 250 40041	CRT fixing screw
7	3111 104 44664	Degaussing coil bracket
8	2422 549 44669	Degaussing coil 21"
9	3139 124 28081	Light guide
10	3139 124 28071	Mains knob
11	2422 264 00401	Loudspeaker 16Ω 5W
12	3139 124 28071	Control knob
13	3139 124 23843	Mains cord relief
14	3139 124 23452	Chassis guide (HB)
15	3139 124 23463	Chassis guide (VO)
	4822 131 11105	Picture tube 21" A51EAL155X47
	4622 009 50511	Mains cord EU
	21PT1346	
	21PT1546	

STYLING 363

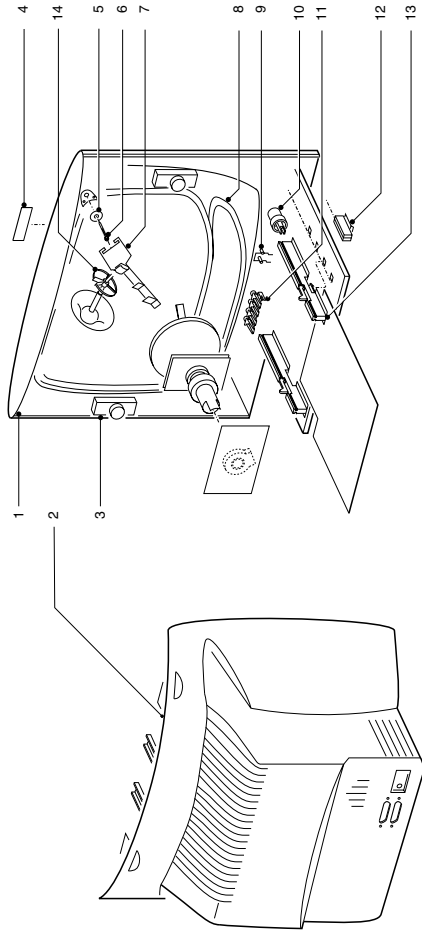
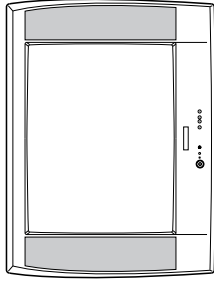
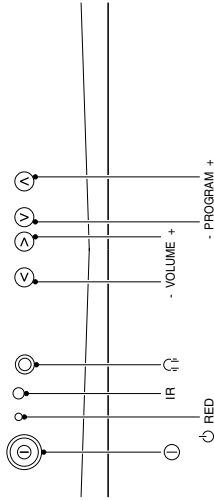

STYLING 363 (SBS 03)
030302

1	3111 257 58071	Cabinet 25"
2	3139 124 38771	Rear Cover 25"
3	2422 264 00401	Loudspeaker 16Ω 5W
4	3111 250 00271	Wordmark Aristona (.../11)
4	3111 250 00261	Wordmark SBR (.../03)
5	4822 401 11765	Coil & EHT bracket
6	4822 505 11195	CRT fixing screw
7	4822 403 70906	Corner coil bracket
8	2422 549 44253	Degaussing coil 25"
9	3139 124 25601	Light guide
10	3139 124 30661	Mains knob
11	3139 124 27071	Control knob
12	3122 224 04623	Mains cord relief
13	3139 124 30871	Chassis guide right (HB)
14	3139 124 30881	Chassis guide left (VO)
	9322 147 09682	Picture tube 25" A59EMZ43X07
	4822 321 11499	Mains cord EU
	4822 321 11493	Mains cord UK
	63TA4416	

STYLING 364

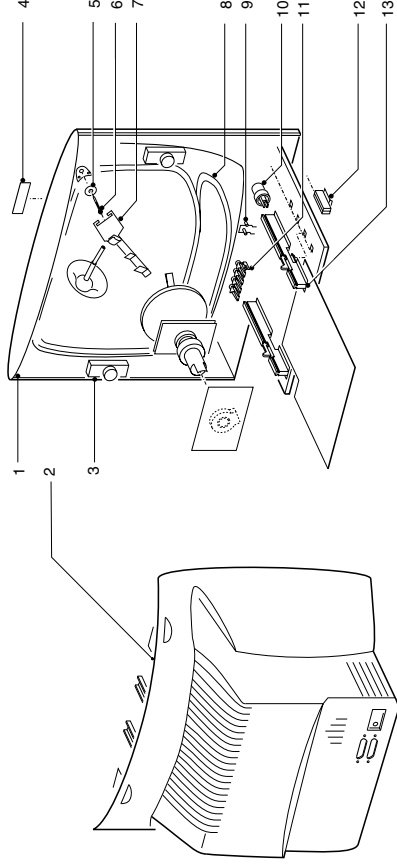
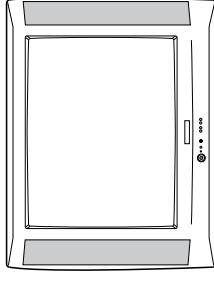
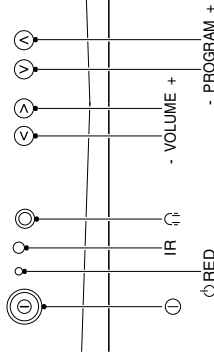

STYLING 364 (SBS 02)
200302

1a*	3111 257 58081	Cabinet 25"
1b*	3111 257 58071	Cabinet 25"
2a*	3139 124 41221	Rear Cover 25"
2b*	3139 124 41341	Rear Cover 25"
3	2422 264 00401	Loudspeaker 16Ω 5W
4a*	4822 459 11155	Wordmark
4b*	3111 250 00201	Wordmark
5	4822 505 11195	CRT fixing screw
6	4822 401 11765	Coil & THT bracket
7	2422 549 44253	Degaussing coil 25"
8	4822 380 10251	Light guide
9	4822 403 70906	Corner coil bracket
10	3139 124 30581	Mains knob
11	3139 124 27071	Control knob
12	4822 466 11453	Mains cord relief
13	3139 124 30881	Chassis guide left (VO)
13	3139 124 30871	Chassis guide right (HB)
	9322 147 09682	Picture tube 25" A59EMZ43X07
	4822 321 11499	Mains cord
	4822 321 11493	Mains cord UK
	4822 404 31363	Mains cord holder
a*	25PT4426	
b*	25PT4107	

STYLING 365

STYLING 366

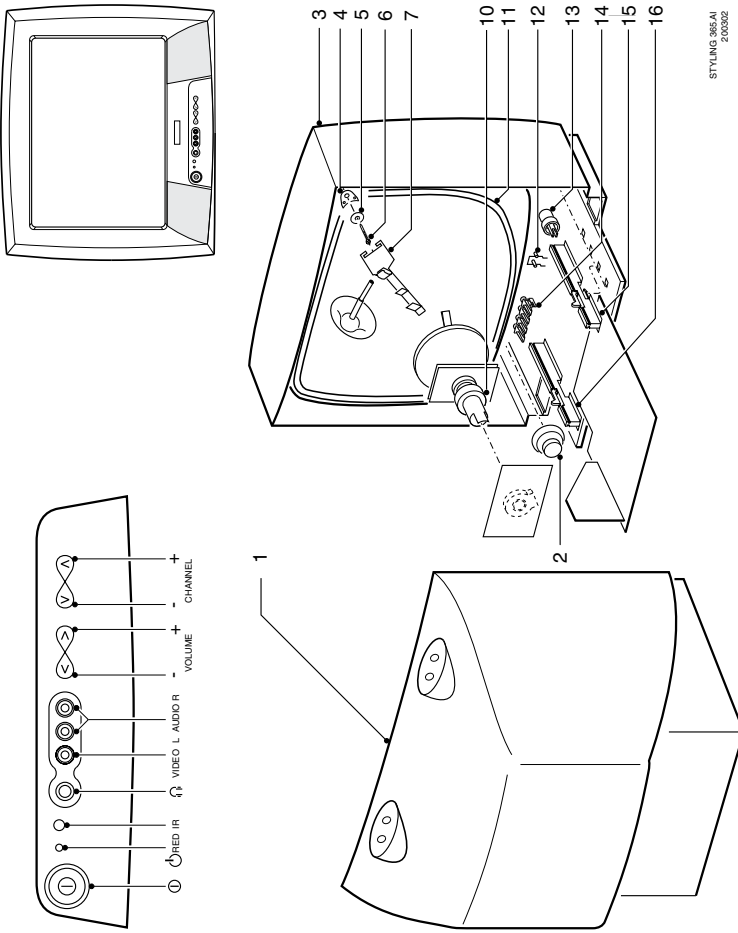

STYLING 365 AI
2/00502

1ac*	3111 254 25141	Rear cover	11	3111 254 09271	Mains knob (silver)
1bd*	3111 254 25391	Rear cover (mid grey)	12	4822 463 11164	Chassis guide right
2	2422 264 00407	Loudspeaker 16Ω 8W	12	4822 463 11165	Chassis guide left
3a*	3111 257 56161	Rod antenna		4822 402 10181	HP fixation
3bd*	3119 108 68842	Loop antenna		4822 321 11499	Mains cord EU
				4822 321 11493	Mains cord UK
3c*	3119 108 68281	Rod antenna		3111 250 00941	Word mark (silver shadow)
4ac*	3111 257 58061	Cabinet 14"		3111 250 00041	Word mark Philips
4bd*	3111 257 58351	Cabinet 14" (metal)		9322 139 76682	Picture tube A34AGT13X95E
5	4822 502 30739	CRT fixing screw		14PT1356/01/58	
6	4822 401 11765	Coil & THT clamp		14PT1356/05	
				14PT1556/05	
6	4822 404 31325	Degaussing coil bracket			
7	4822 380 10218	Light guide			
8ab*	3119 104 23763	Degaussing coil 14"			
8cd*	2422 549 44844	Degaussing coil 14"			
10	3111 254 09281	Control knobs (silver)			

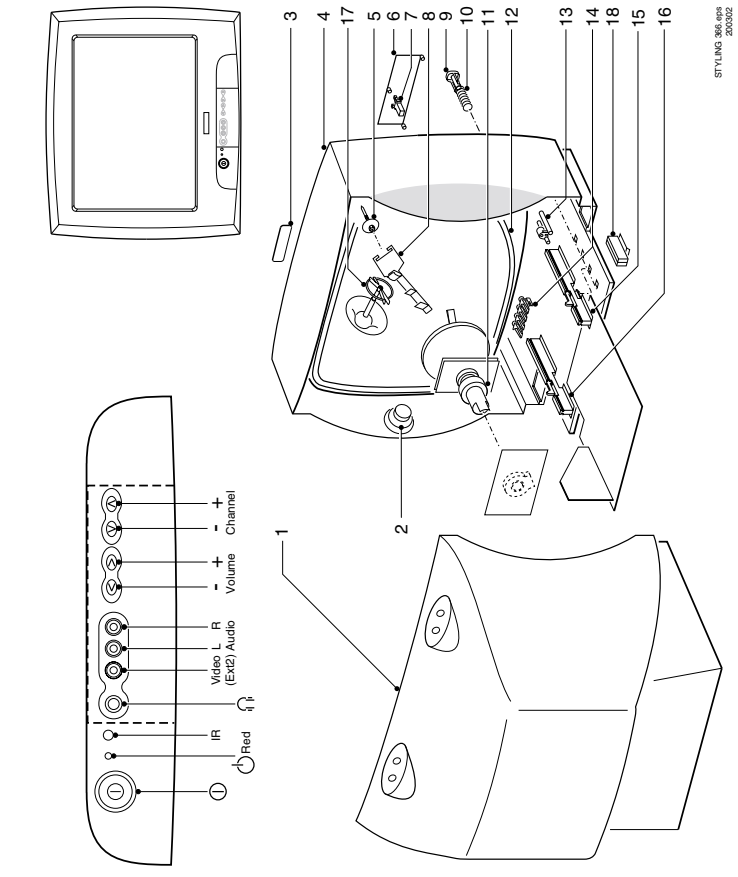

STYLING 366 095
2/00502

1	3111 257 58501	Rear cover 21"			
2	2422 264 00414	Loudspeaker 8Ω 5W			
3	3111 250 00741	Wordmark			
4	3111 257 57001	Cabinet 21"			
5	3119 100 42081	CRT fixing screw			
6	3111 254 10041	Door			
7	3111 254 22541	Stopper			
8	3119 104 18247	Degaussing coil bracket			
9	3111 254 09871	Mains knob			
10	Not applicable				
11	Not applicable				
12	2422 549 44669	Degaussing coil 21"			
13	3111 254 24251	Light guide			
14	3111 254 24241	Knob frame			
15	3111 254 24152	Right chassis guide			
16	Not applicable				
17	3111 254 23481	Coil EHT clamp			
18	Not applicable				
	3111 257 71451	Stand (silver) UK only			
	9322 165 89682	Picture tube 21" A51EER33X72			
	4822 321 11493	Mains cord UK			
	4822 321 11499	Mains cord EU			

STYLING 367

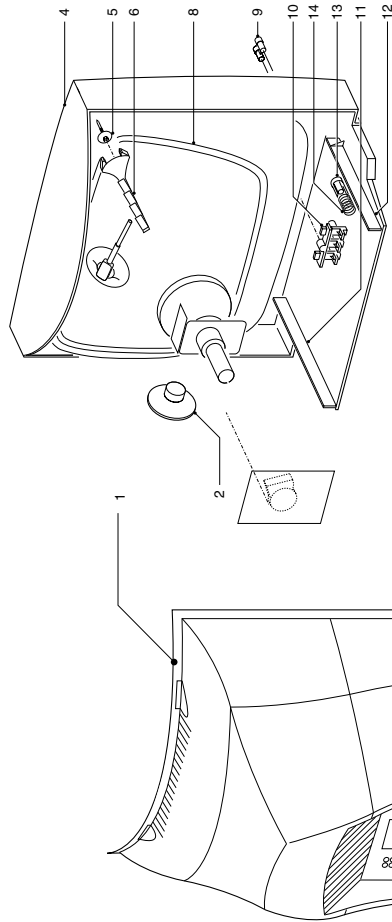
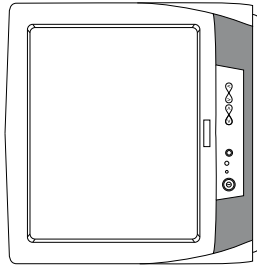
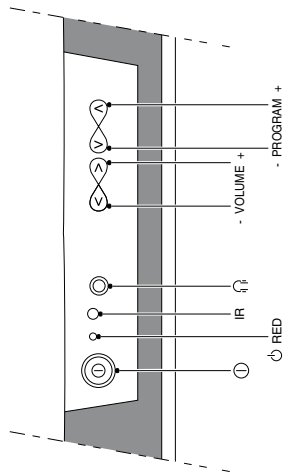

Styling 367, nps
140382

1	3111 254 25121	Rear cover
2	2422 264 00399	Loudspeaker 16Ω 4W
3	3111 257 57931	Cabinet (mono)
4	4822 502 14071	CRT fixing screw
5	4822 401 11765	Coil & THT clamp
6	2422 549 44669	Degaussing coil
7	4822 404 30839	Corner coil bracket
8	3111 254 24511	Light guide
9	3111 254 24503	Control knob
10	3111 254 24492	Spring for mains knob
11	3111 254 24492	Mains knob
12	4822 463 11167	Chassis guide left
13	4822 463 11166	Chassis guide right
	4822 321 11499	Mains cord EU
	4822 404 31291	Mains cord holder
	4822 459 11157	Wordmark
	4822 131 11105	Picture tube 21"
	9322 165 89682	A51EAL155X47
		Picture tube 21"
		A51EER33X72 (.../21)

21PT1356
21PT1556

STYLING 368

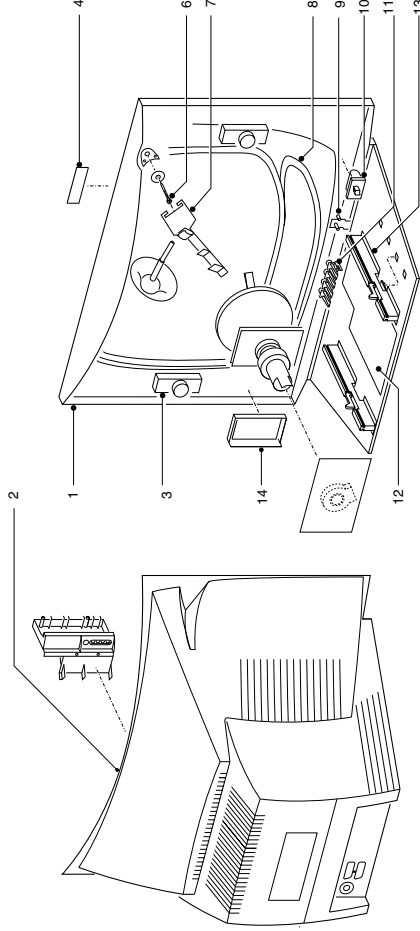
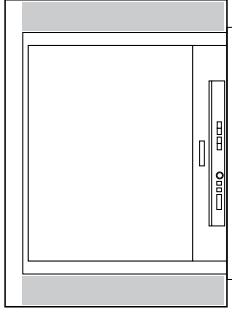
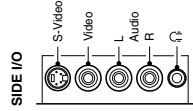
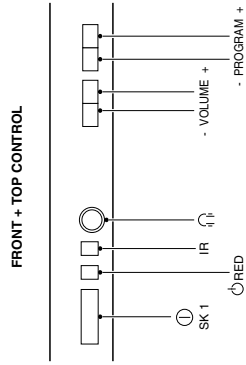

Styling 368, nps
300382

1	3139 137 91971	Cabinet 25"
2	3139 137 79781	Rear cover 25"
3	2422 264 00409	Loudspeaker 8Ω 5W
4	3111 250 00731	Wordmark Philips
5	4822 401 11765	Coil & THT clamp
6	3139 124 23861	Tube spacer
7	4822 505 11195	CRT fixing screw
8	4822 403 70906	Corner coil bracket
9	2422 549 44253	Degaussing coil 25"
10	3139 124 32221	Light guide
11	3139 124 36331	Mains knob
12	3139 124 36311	Control knob
13	3139 124 30881	Chassis guide (VO)
14	4822 466 11453	Mains cord relief
15	3139 124 33341	VO plate
	9322 163 87682	Picture tube A59QDF891X001
	4822 321 11499	Mains cord EU
	4822 321 11493	Mains cord UK

25PT5506

STYLING 369

FRONT + TOP CONTROL

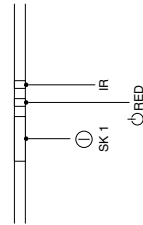

SIDE I/O

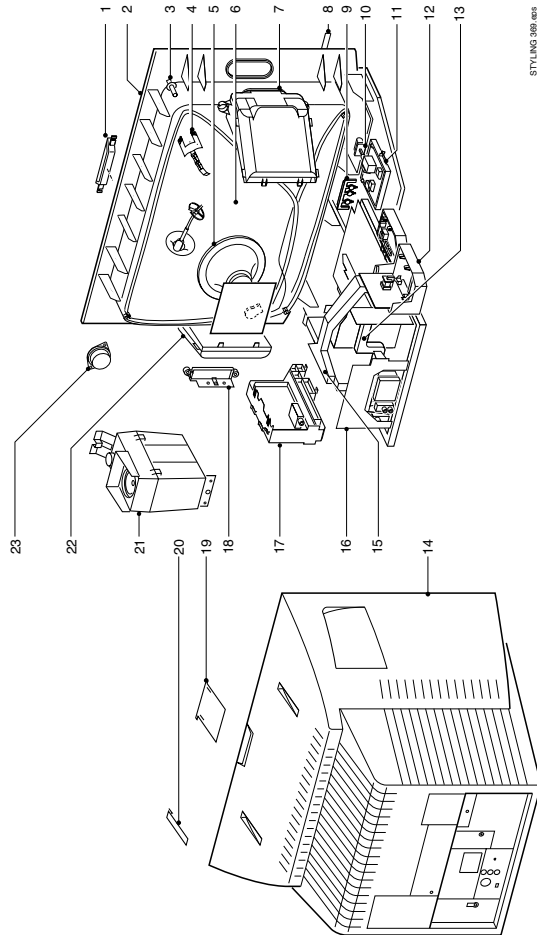
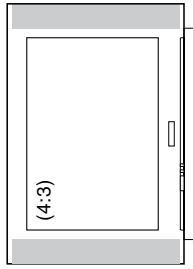
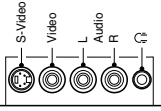

STYLING 369.000
210302

1ab*	3139 138 12751	Top control Assy	20ab*	3139 128 23451	Degaussing coil
2ab*	3139 138 19011	Cabinet	21	9322 160 14682	CRT A680CP891X500 (29"/56 & /57 only)
3ab*	3111 250 40031	CRT screw	21	9322 160 15682	CRT A680CP891X501 (29"/69 only)
4ab*	3139 124 31122	Degaussing coil bracket	22	3104 304 21114	LOT & SSB support bracket
5ab*	3139 138 60652	Rotation coil	0066	3104 308 73224	Antenna IEC cable
6ab*	3139 124 39581	Rotation coil bracket	0072	3139 124 39211	Light guide
7ab*	3139 128 76611	Speaker & box Assy (right)	0082	3139 124 26301	Mains cord relief
8ab*	3141 050 00161	Wordmark PHILIPS	0194	3104 304 24111	SSB snap
9ab*	3139 138 10681	Mains knob Assy	1322 504 97401		Grease for EHT cap
10ab*	3139 124 32522	Front interface bracket	*a	29PT8320	
11ab*	3104 304 21653	DAF & DC shift bracket	*b	29PT8420	
12a*	3139 124 39741	Rear cover (w/o DW)			
12b*	3139 124 39331	Rear cover			
13b*	3104 304 22073	Double window bracket			
14ab*	3139 124 40131	Side AV bracket			
15ab*	3139 124 39161	VO plate for rear cover			
16ab*	3139 124 39301	Screw cap for rear cover			
17ab*	3139 128 76491	Subwoofer box			
18ab*	3139 128 76601	Speaker & box Assy (left)			
19ab*	2422 264 00388	Tweeter 8Ω 8W			

STYLING 370

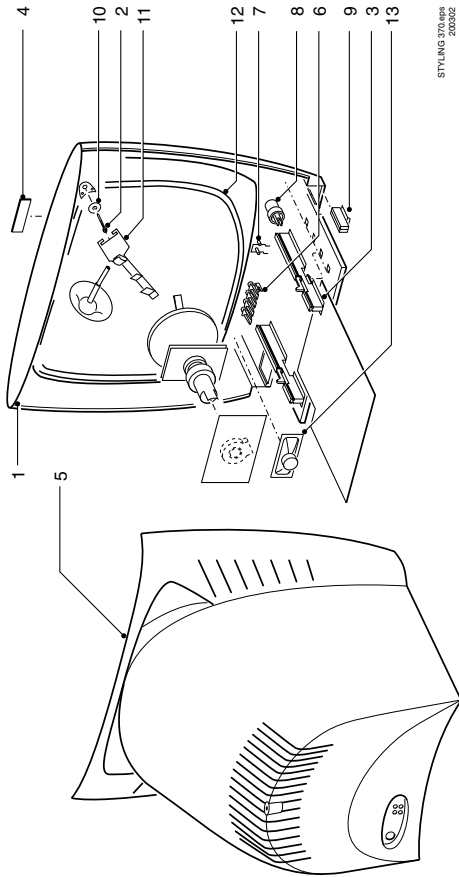
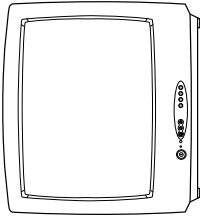
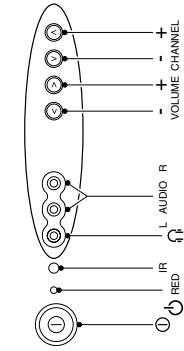

STYLING 370.000
200302

1	3139 137 85781	Cabinet	5	3139 124 36671	Rear cover(ZAV)
2	3139 120 41141	CRT fixing screw	6	3139 124 39761	Control knob
3	3139 124 23452	Chassis guide (HB)	7	3139 124 26252	Light guide*
3	3139 124 23463	Chassis guide (VO)	8	3139 124 39771	Mains knob
4	3139 120 01271	Wordmark	9	3139 124 23843	Mains cord relief
5	3139 124 36671	Rear cover(ZAV)	10	3139 124 23882	Tube spacer
6	3139 124 39761	Control knob	11	3139 124 10113	Bracket
7	3139 124 26252	Light guide*	12	3139 128 23151	Degaussing coil 14" multi volt
8	3139 124 39771	Mains knob	13	2422 264 00408	Loudspeaker 8Ω 5W
9	3139 124 23843	Mains cord relief		9322 137 86882	Picture tube 14" A34AGT13X95
10	3139 124 23882	Tube spacer			
11	3139 124 10113	Bracket			
12	3139 128 23151	Degaussing coil 14" multi volt			
13	2422 264 00408	Loudspeaker 8Ω 5W			

STYLING 371

STYLING 373

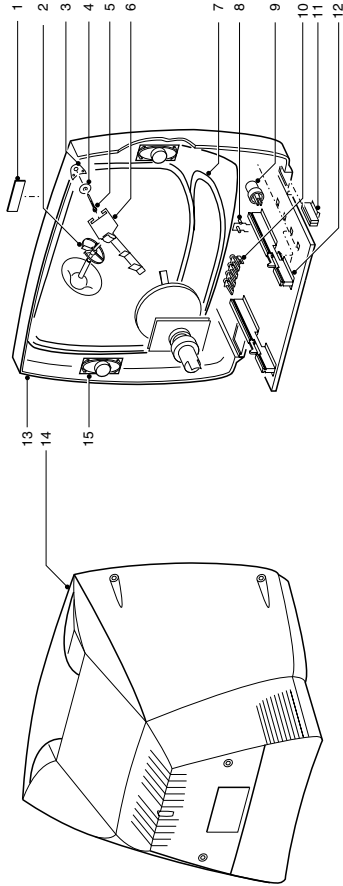
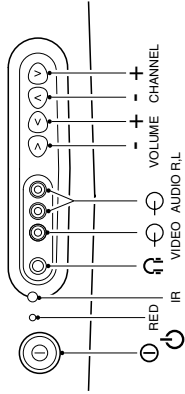
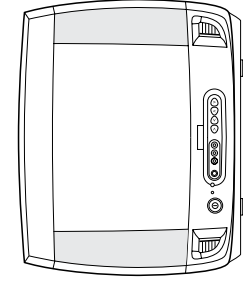

STYLING 371 APP
200302

1	3139 120 01271	Wordmark
2	Not applicable	
3	3139 124 28491	Tube spacer
4	Not applicable	
5	3139 120 41141	CRT fixing screw
6	3139 124 10113	Bracket
7	3139 128 23151	Degaussing coil 14"
8	3139 124 27781	Light guide
9	3139 137 89201	Mains knob
10	3139 137 89191	Control knob
11	3139 124 23843	Mains cord relief
12	3139 124 23463	Chassis guide (VO)
13	3139 137 85261	Cabinet (HP+2AV+FC)
14	3139 124 36371	Rear cover (4AV)
15	2422 264 00399	Loudspeaker 16Ω 4W
	9322 137 68682	Picture tube 14" A34AGT13X95

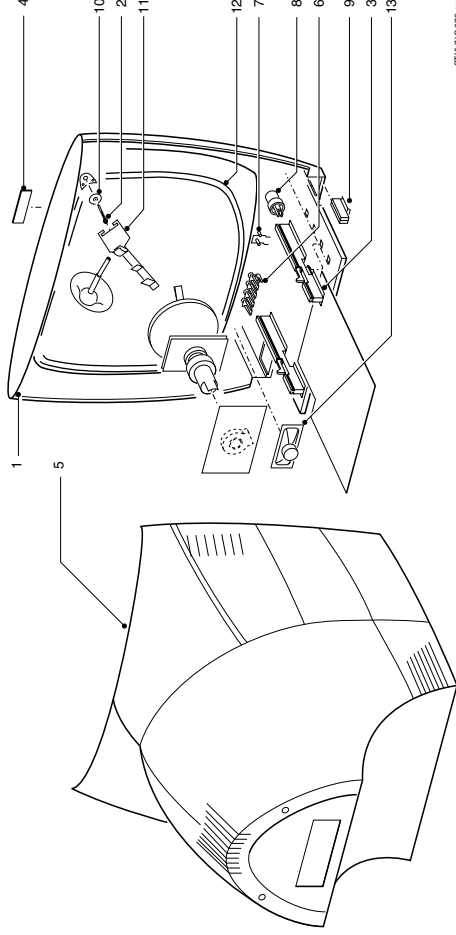
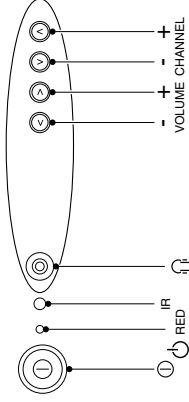
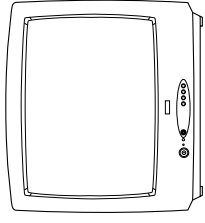

STYLING 373 APP
200302

1	3139 137 85811	Cabinet 20" (NHP+NAV+FC)
2	3139 120 41141	CRT fixing screw
3	3139 124 23452	Chassis guide (HB)
3	3139 124 23463	Chassis guide (VO)
4	3139 120 01281	Wordmark
5	3139 124 36291	Rear cover 20"
6	3139 124 39761	Control knob
7	3139 124 26193	Light guide
8	3139 124 39771	Mains knob
9	3139 124 23843	Mains cord relief
10	3139 124 23882	Tube spacer
11	3139 124 20114	Bracket
12	3139 128 23201	Degaussing coil 21"
13	2422 264 00342	Loudspeaker 8Ω 6W
	9322 137 70682	Picture tube 20" A48AGY13X95

STYLING 374

FRONT + TOP CONTROL

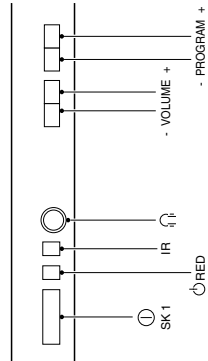

SIDE I/O

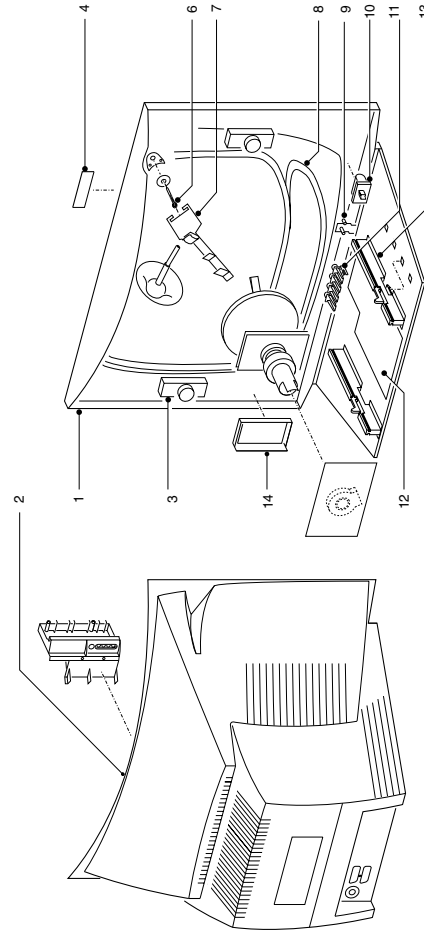
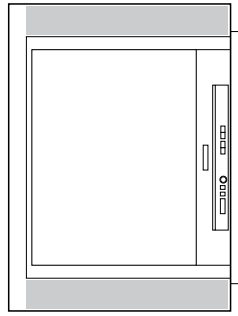
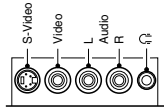

©/Rev. 374.000
2003B2

1a*	3139 138 15271	Cabinet 21"
1b*	3139 137 79751	Cabinet 21" ITV
2a*	3139 124 34591	Rear cover (6AV+S)
2b*	3139 124 36681	Rear cover (9AV) ITV
3	2422 264 00444	Loudspeaker 8Ω 10W
4	3139 120 01371	Wordmark (metal silver)
5	3141 054 22011	CRT spacer
6	3104 308 77012	CRT fixing screw
7	3139 124 21372	Degaussing coil bracket
8	3139 128 23201	Degaussing coil 21"
9	3139 124 32221	Light guide
10	3139 124 36331	Mains knob
11	3139 124 36311	Control knob
12	3139 124 39541	Side-AV bracket
13	3139 124 30812	Chassis guide (VO)
14	3139 124 33341	VO plate
	9322 153 82682	Picture tube 21" A51LSK955X01

*a

*b

- 21PT2252/56A
- 21PT2252/57R
- 21PT2252/68R
- 21PT2252/69R
- 21PT2252/79R
- 21PT2251/97R
- 21PT2212/67R
- 21PT2211/68Z

STYLING 375

FRONT + TOP CONTROL

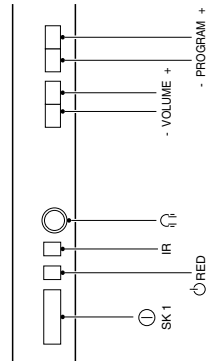

SIDE I/O

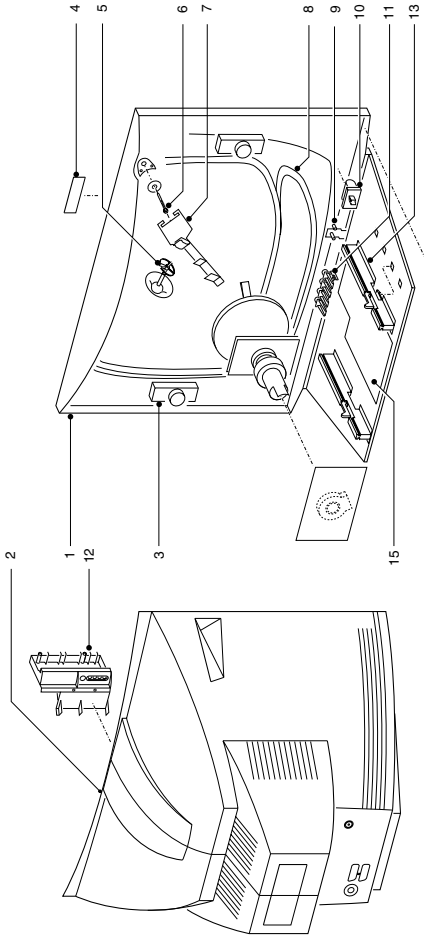
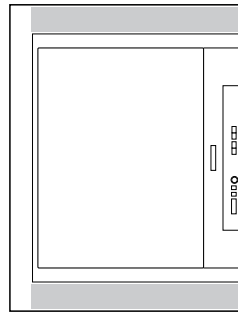
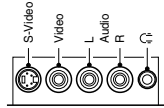

©/Rev. 375.000
2003B2

1	3139 13785831	Cabinet (HP+FC)
2a*	3139 124 35741	Rear cover 21" (4AV+FM)
2b*	3139 124 35881	Rear cover 21" ITV
3	3141 050 00181	Wordmark
4	3139 120 41141	CRT fixing screw
5	3139 124 10113	Bracket
6	3139 128 23201	Degaussing coil 21" multi volt
7	3139 137 86011	Control knob
8	3139 137 86061	Mains knob
9	Not applicable	
10	3139 124 30812	Chassis guide (VO)
11	3139 124 34401	Light guide
12	Not applicable	
13	Not applicable	
14	2422 264 00411	Loudspeaker 16Ω 5W
15	3139 124 33291	VO plate
	9301 843 10329	Picture tube 21" A51EHW135X47

*a

*b

- 21PT2012/59A
- 21PT2012/59B
- 21PT2012/79R
- 21PT2012/59C
- 21HT2017/69Y
- 21HT2017/79Y

STYLING 376

FRONT + TOP CONTROL

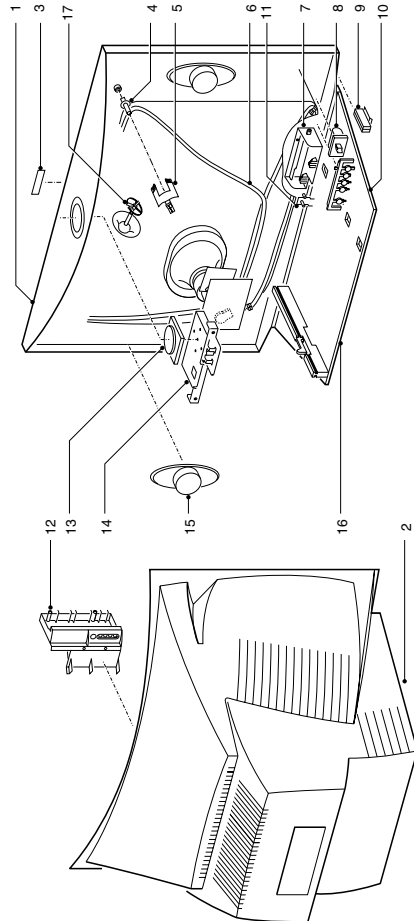
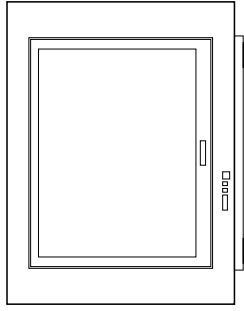
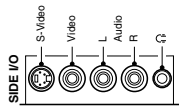
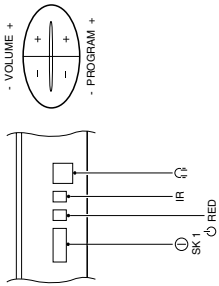

STYLING 376
200302

1a*	3139 124 37751	Rear cover 21" (2AV)
1b*	3139 124 38191	Rear cover 21" (2AV+SPLS)ITV
2	2422 264 00401	Loudspeaker 16Ω 5W
3	Not applicable	
4	3139 137 85031	Cabinet 21"
5	3139 120 41141	CRT fixing screw
6	3139 124 10113	Bracket
7	3141 050 00181	Wordmark
8	3139 128 23201	Degaussing coil 21" multi volt
9	3139 124 25852	Light guide
10	3139 137 69702	Control knob
11	3139 124 24752	Chassis guide (HB)
12	3139 124 24783	Chassis guide (VO)
13	3139 137 69692	Mains knob
14	Not applicable	
15	3139 124 23843	Mains cord relief
	9301 843 10329	Picture tube 21" A51EHW135X47

*a

21PT200179R
21PT200179B
21HT200179Z
21HT200179Z
21HT200279R

STYLING 377

FRONT + TOP CONTROL

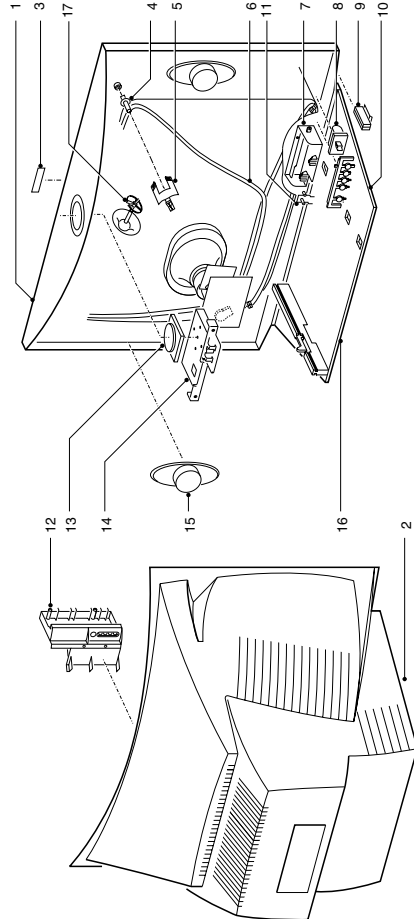
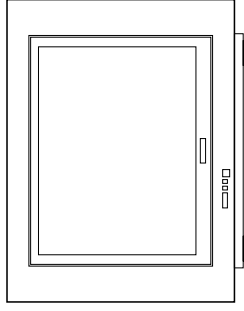
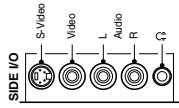
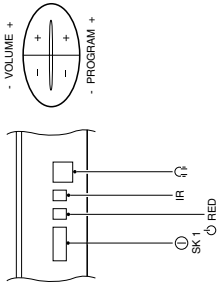

STYLING 377
200302

1	3139 138 17631	Cabinet 21"
2	3139 124 34591	Rear cover 21" (6AV+S)
3	3139 120 01371	Wordmark (metal)
4	3104 308 77012	CRT fixing screw
5	3139 124 21372	Degaussing coil bracket
6	3139 128 23201	Degaussing coil 21" multi volt
7	Not applicable	
8	3139 137 76521	Mains knob
9	Not applicable	
10	3139 124 33341	V0 plate
11	3139 124 32221	Light guide
12	3139 124 39541	Side-AV bracket(HP+3AV)
13	3139 124 31131	Top control cover
14	3139 124 30381	Top control bracket
15	2422 264 00444	Loudspeaker 8Ω 10W
16	3139 124 30812	Chassis guide (VO)
17	Not applicable	

9322 153 82682

Picture tube 21" A51LSK955X01

STYLING 378

FRONT + TOP CONTROL

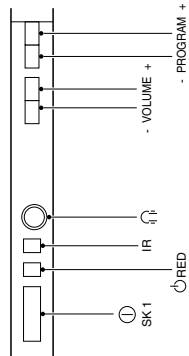

SIDE I/O

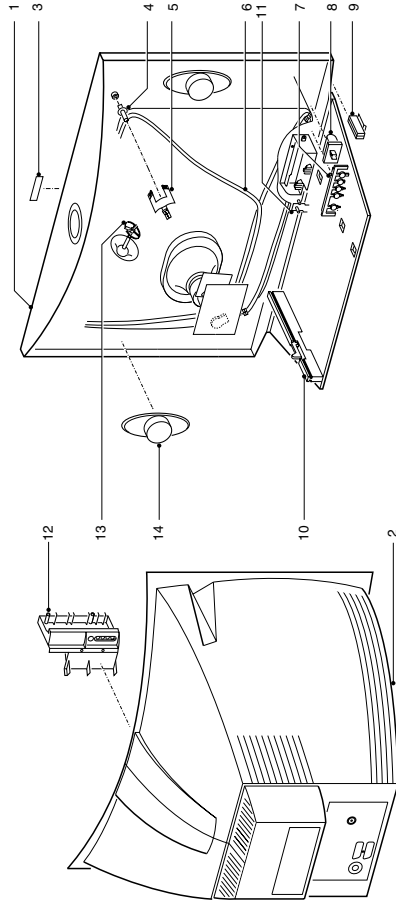
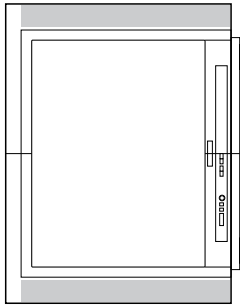
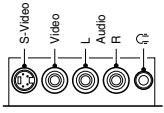

© Philips 378.006
200182

- | | | |
|----|----------------|--------------------------------|
| 1 | 3139 137 90211 | Cabinet 25" |
| 2 | 3139 124 34971 | Rear cover 25" |
| 3 | 3141 050 00091 | Wordmark |
| 4 | 3104 308 77012 | CRT fixing screw |
| 5 | 3139 124 21802 | Coil clamp |
| 6 | 3139 128 23371 | Degaussing coil 21" multi volt |
| 7 | 3139 137 93791 | Control knob |
| 8 | 3139 137 93781 | Mains knob |
| 9 | Not applicable | |
| 10 | 3139 124 25893 | Chassis guide (VO) |
| 11 | 3139 124 35661 | Light guide |
| 12 | 3139 124 39541 | Side-AV bracket(HP+3AV) |
| 13 | 3139 124 17541 | EHT spacer |
| 14 | 2422 264 00409 | Loudspeaker 8Ω 5W |
| 15 | 3139 124 23861 | Tube spacer |
| | 9301 791 90365 | Picture tube 25" A59EEJ71X11 |

STYLING 380

FRONT CONTROL

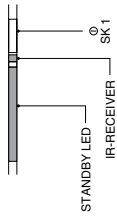

TOP CONTROL

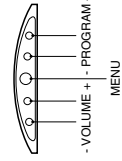

SIDE I/O

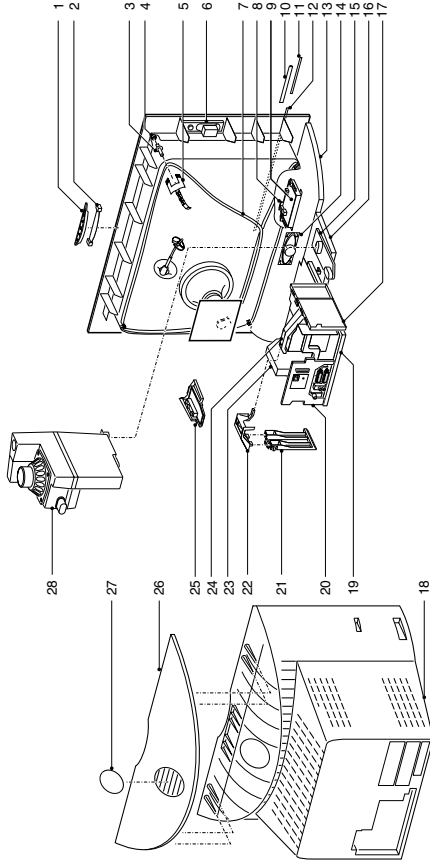
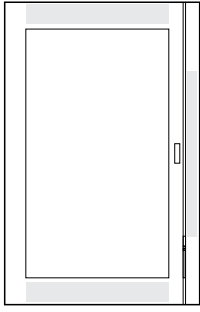
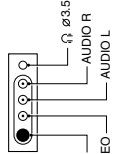

STYLING 380.006
150002

- | | | |
|----|----------------|------------------------------|
| 1 | 3104 307 98521 | Rear cover Assy |
| 2 | 3104 304 21331 | Coverplate SCART3/wireless |
| 3 | 3104 304 24241 | Subwoofer box |
| 4 | 3104 304 24241 | Subwoofer support bracket |
| 5 | 3104 307 98641 | Top cover (incl. VO) |
| 6 | 3104 304 24131 | LOT support bracket |
| 7 | 3104 328 17431 | Side I/O Assy |
| 8 | 3104 304 23481 | Bracket for SSB top support |
| 9 | 3104 301 24131 | Shielding frame SSB (A-side) |
| 10 | 3104 301 24141 | Shielding frame SSB (Z-side) |
| 11 | 3104 301 24151 | Shielding cover SSB (A-side) |
| 12 | 3104 301 24161 | Shielding cover SSB (Z-side) |
| 13 | 3104 328 17131 | Top control Assy |
| 14 | 3104 307 97611 | Top control insert |
| 15 | 3104 307 98241 | Top control keypad |
| 16 | 3104 304 23431 | Top control bottom |
| 17 | 3104 308 74023 | Insert VP19000 |
| 18 | 3104 304 23461 | Light guide |
| 19 | 3104 304 23621 | Deco strip left |
| 20 | 3104 304 23631 | Deco strip right |
| 21 | 3104 328 16572 | Cabinet |
| 22 | 2422 264 00431 | Centre loudspeaker (1x) |
| 23 | 3104 304 23501 | Bottom plate |
| 24 | 3104 304 23002 | Frame for LSP |
| | 3104 300 12311 | Matchline emblem |
| | 3104 300 12241 | Philips wordmark |
| | 2422 549 44244 | Degaussing coil |
| | 3128 138 60661 | Rotation coil |
| | 9301 852 00314 | Picture tube |
| | 3128 147 13981 | Remote control |
| | 4622 009 50491 | Mains cord (/05 only = UK) |
| | 4622 009 50511 | Mains cord (/12) |
| | 3104 304 20182 | Mains cord holder |
| | 32PW9527/xx | |

STYLING 382

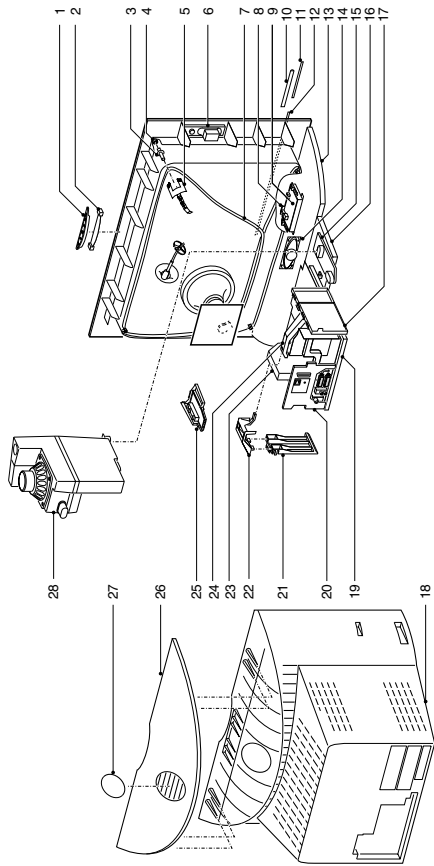
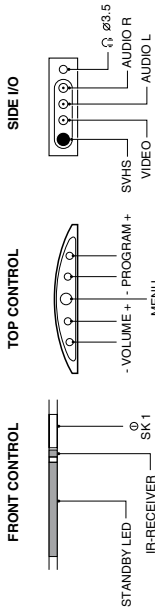
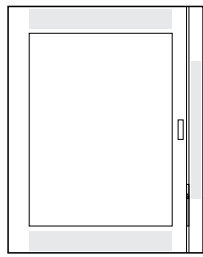

STYLING 382 ASSY
190302

1	3104 307 97501	Rear cover assy	19	3104 304 23551	Deco strip left
2	3104 304 24241	Subwoofer box	20	3104 304 23541	Deco strip right
3	3104 304 24241	Subwoofer support bracket	21	3104 328 12231	Cabinet
4	3104 307 97561	Top cover (incl. VO)	22	2422 264 00431	Centre loudspeaker (1x)
5	3104 304 24131	LOT support bracket	23	3104 304 24231	Bottom plate
6	3104 328 17431	Side I/O assy	24	3104 304 23002	Frame for LSP
7	3104 304 23481	Shielding cover SSB (Z-side)		3104 300 12311	Matchline emblem
8	3104 304 24151	Bracket for SSB top support		3104 300 12231	Philips wordmark
9	3104 301 24131	Shielding frame SSB (A-side)		3104 304 23041	Bracket for DAF panel
10	3104 301 24141	Shielding frame SSB (Z-side)		2422 549 44579	Degaussing coil
11	3104 301 24161	Shielding cover SSB (A-side)		3139 124 39581	Bracket for rotation coil
12	3104 328 19791	Top control assy		3128 138 60661	Rotation coil
13	3104 307 98831	Top control insert		9322 160 16682	Picture tube
14	3104 307 98241	Top control keypad		3104 207 09581	Remote control
15	3104 304 23431	Top control bottom		2422 070 98132	Mains cord
16	4822 505 11195	Picture tube screw		3104 304 20182	Mains cord holder
17	3139 124 31122	Bracket fix deg. coil (4x)		?	Bracket for PIP/DW panel
18	2422 264 00429	L/R loudspeaker (2x)		29PT9420/79R	
19	3104 304 23471	Bracket for mains switch panel			
20	3104 307 97621	Mains switch knob			
21	3104 304 23461	Light guide			

STYLING 383

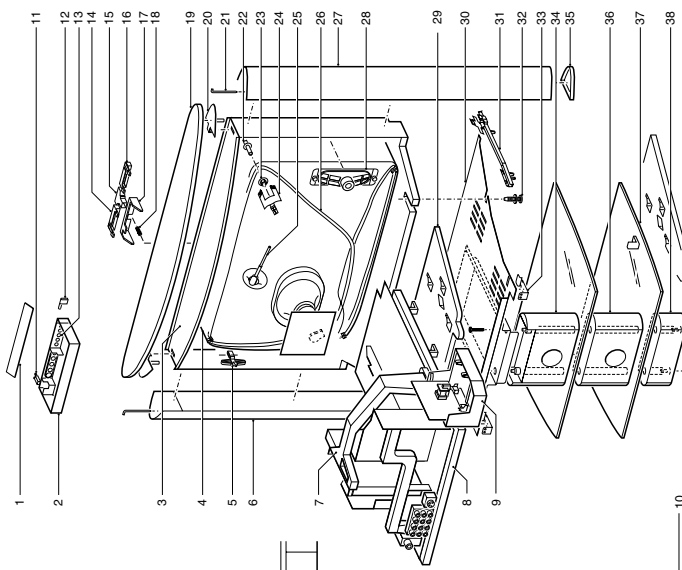
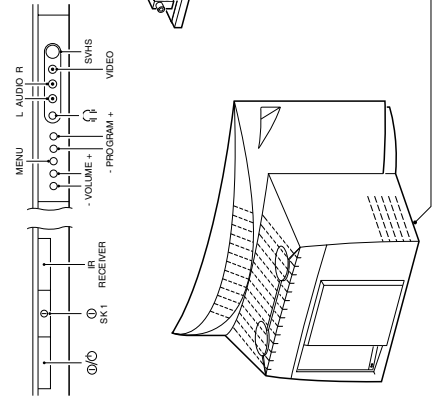
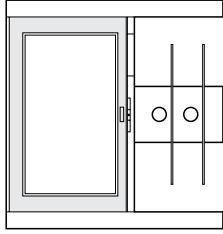

STYLING 383 ASSY
21002

1	3104 307 96921	Door	25	3104 311 03272	EHT cable
2	3104 304 22621	Bracket front controls	26	2422 549 44244	Degaussing coil
3	3104 307 98921	Cover aluminum column right	27	3104 307 99271	Aluminum column left Green
4	3104 328 20351	Cabinet assy 32PW9594 Green	27	3104 307 99291	Aluminum column left Blue
5	3104 328 20361	Cabinet assy 32PW9595 Blue	27	3104 307 99291	Aluminum column left Brown
6	3104 328 20341	Cabinet assy 32PW9596 Brown	28	2422 264 00386	Loudspeaker (2x)
7	9301 880 70314	CRT W76ERF042X044	29	3104 304 22012	Bottom plate
8	3104 307 99261	Aluminum column right Green	30	9965 000 07349	Top plate stand
9	3104 307 99281	Aluminum column right Blue	31	4822 402 11163	Mains cord relief
10	3104 307 99281	Aluminum column right Brown	32	3104 308 78041	Screw for stand assy
11	3104 304 21114	LOT support bracket	33	9965 000 07348	Steel clip
12	3104 304 23001	Frame for LSP	34	Not available yet	Back column part, 1 shelf
13	3104 304 23041	Bracket for DAF/DC shift panel	34	Not available yet	Back column part, 2 shelf
14	3104 307 99481	Rear cover 32PW9594 Green	35	3104 304 22691	Foot right
15	3104 307 99491	Rear cover 32PW9595 Blue	35	3104 304 22701	Foot left
16	3104 307 99471	Rear cover 32PW9596 Brown	36	Not available yet	Back column part, 1 shelf
17	3104 308 70381	Locking unit	36	Not available yet	Back column part, 2 shelf
18	3104 308 78011	Damped hinge	37	9965 000 07389	Glass plate
19	3104 304 22661	Knob frame controls	37	Not available yet	Back column part, 2 shelf
20	3104 304 22671	Window right			
21	3104 307 96911	Mains knob assy			
22	3104 304 22681	Window left			
23	3104 304 22601	Support for mains switch			
24	Not present	Spring			
25	3104 304 99331	Top plate 32PW9594 Green	3104 308 78251	Rear leg stand assy	32PW9594 Green
26	3104 304 99341	Top plate 32PW9595 Blue	3104 308 78261	Rear leg stand assy	32PW9595 Blue
27	3104 304 99321	Top plate 32PW9596 Brown			
28	3104 307 99631	Cover aluminum column left			
29	3104 307 99631	Cover aluminum column right			
30	4822 502 21359	CRT screw	4622 009 50782	Mains cord for -05	
31	4822 404 31289	Bracket fix degaussing coil (2x)	4622 009 50772	Mains cord for -12	
32	4822 403 70906	Bracket fix degaussing coil (2x)	3104 300 12341	Wordmark 32PW9594 Green	
33			3104 300 12351	Wordmark 32PW9595 Blue	
34			3104 308 77981	Focus cable	
35			4822 157 11825	Rotation coil	
36			3104 207 09561	Remote control RC2031/01B	