

INSTALLATION, OPERATION, SERVICE & PARTS SUPPLEMENT for

Rooftop Energy Storage Systems (ESS)

AIR COOLING UNIT

77-62186-00 THRU -04

&

77-62203-00

T-333

REV. 03/2012



TABLE OF CONTENTS

PARAGRAPH NUMBER	Page
INSTALLATION	1-1
1.1 Introduction	1-1
1.2 Electrical	1-1
1.3 Installation	1-3
OPERATION & SERVICE	2-1
2.1 OPERATION	2-1
2.1.1 Air Circulation	2-1
2.1.2 Refrigerant Cycle	2-1
2.2 MAINTENANCE SCHEDULE	2-2
2.2.1 Scheduled Maintenance	2-2
2.3 REFRIGERANT LEAK CHECK	2-2
2.4 EVACUATION AND DEHYDRATION	2-2
2.5 ADDING REFRIGERANT TO SYSTEM	2-2
2.6 SERVICING THE LIQUID LINE SOLENOID VALVE	2-2
2.6.1 Coil Replacement	2-2
2.6.2 Internal Part Replacement	2-2
2.6.3 Replace Entire Valve	2-3
2.7 THERMOSTATIC EXPANSION VALVE (Block)	2-3
2.7.1 Valve Replacement	2-3
2.8 COIL FREEZE THERMOSTAT (Freeze-Stat)	2-3
2.9 HIGH PRESSURE SWITCH (Optional)	2-3
SERVICE PARTS	3-1
INTRODUCTION	3-1
CONFIGURATION IDENTIFICATION	3-1
MODEL CHART	3-1
GENERAL NOTES	3-1
3.1 ESS COOLING SYSTEM 12/24V - COMMON PARTS - 77-62186-00 THRU -04	3-2
3.2 ESS COOLING SYSTEM 12/24V MIO CONNECTIONS - 77-62186-00 AND -01 ...	3-4
3.3 ESS COOLING SYSTEM 12/24V ORS CONNECTIONS - 77-62186-02, -03 AND -04	3-5
3.4 ESS COOLING SYSTEM - HARNESS 77-62186-00 THROUGH -03	3-6
3.5 ESS COOLING SYSTEM - HARNESS 77-62186-04	3-6
3.6 ESS COOLING SYSTEM - 24V ORS CONNECTIONS (MCI) - 77-62203-00	3-7
3.6 ESS COOLING SYSTEM - 24V ORS CONNECTIONS (MCI) - 77-62203-00	3-8
3.7 ESS COOLING SYSTEM - SUCTION TUBE ASSEMBLY FOR 77-62203-00	3-10
3.8 ESS COOLING SYSTEM - LIQUID TUBE ASSEMBLY FOR 77-62203-00	3-10
3.9 ESS COOLING SYSTEM - HARNESS FOR 77-62203-00 (MCI)	3-11



LIST OF FIGURES

Figure 1-1 ESS Air Cooler & Components	1-1
Figure 1-2 Electrical Schematic (ESS Air Cooler W/Micromax) Rooftop (RF) Application	1-1
Figure 1-3 Electrical Schematic (ESS Air Cooler W/Micromax) Rearmount (RM55) Application . .	1-2
Figure 1-4 Electrical Schematic (ESS Air Cooler W/Micromax) Rearmount (RM50) Application . .	1-2
Figure 1-5 ESS With Air Cooler Installed	1-3
Figure 2-1 Air Cooler Operation	2-1
Figure 2-2 Air Cooler Refrigerant Flow Diagram	2-2
Figure 2-3 Liquid Line Solenoid Valve	2-3

SECTION 1 INSTALLATION

1.1 Introduction

The MCC Rooftop ESS (Energy Storage System) Air Cooling Unit (See Figure 1-1) is a one piece assembly consisting of an evaporator coil, expansion valve (TXV), liquid line, solenoid valve, suction line and a freeze thermostat. The ESS Air Cooling Unit is used

in conjunction with a MCC Rooftop (RF) or Rear Mounted (RM) main air conditioning system and a Micromax Controller. The purpose of the air cooler is to aid in keeping the hybrid bus battery pack (ESS) cool. The ESS has its own fans that provide airflow (ventilation system). The MCC ESS Air Cooler is integrated into that ventilation system.

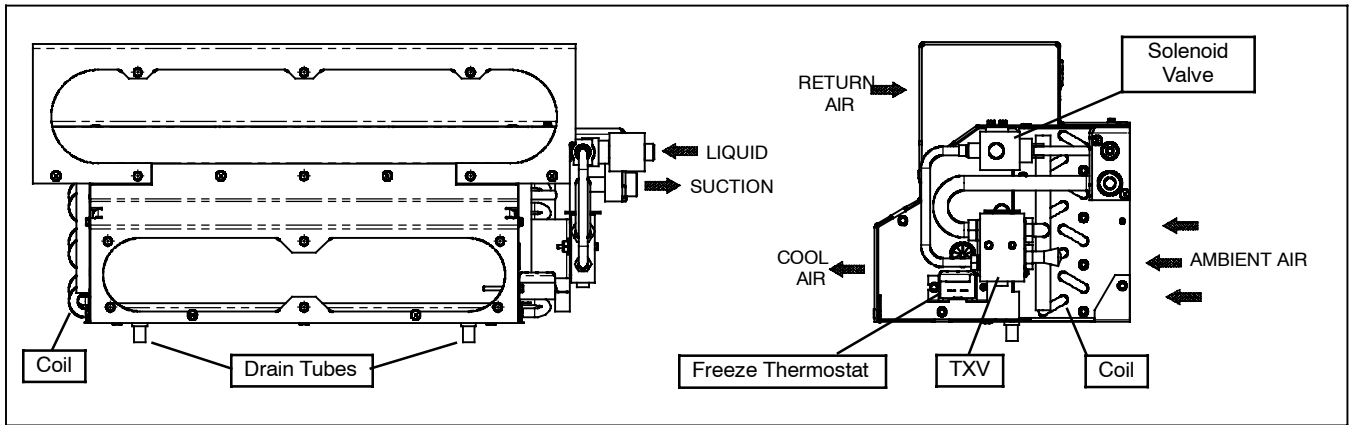

Figure 1-1 ESS Air Cooler & Components

1.2 Electrical

Movement of refrigerant through the MCC Air Cooling Unit is controlled by the electrical system of the main air conditioning system (See Figure 1-2, Figure 1-3 or Figure 1-4).

The internal components of the ESS along with the MCC Air Cooling Unit must have sufficient air movement to keep the ESS temperature under 30° C (86° F).

Note

The Air Cooler will not operate unless the main evaporator assembly is in the cool mode.

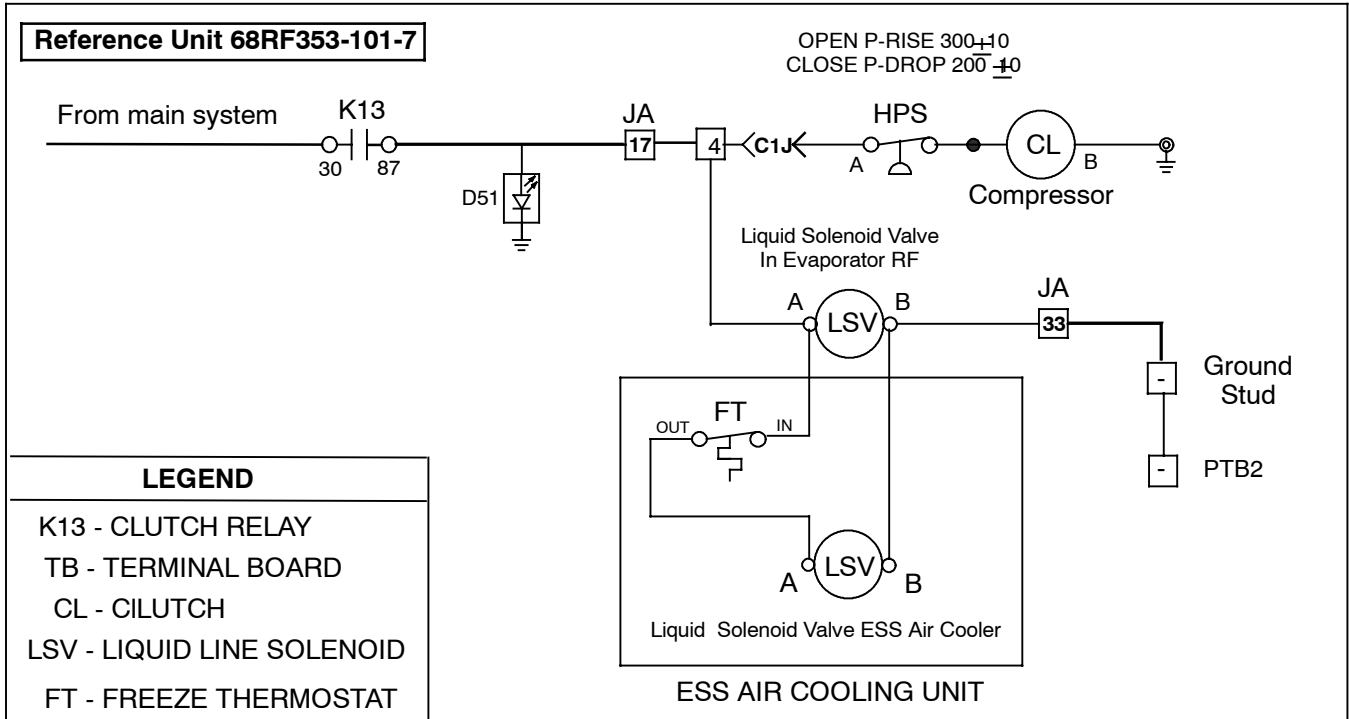

Figure 1-2 Electrical Schematic (ESS Air Cooler W/Micromax) Rooftop (RF) Application

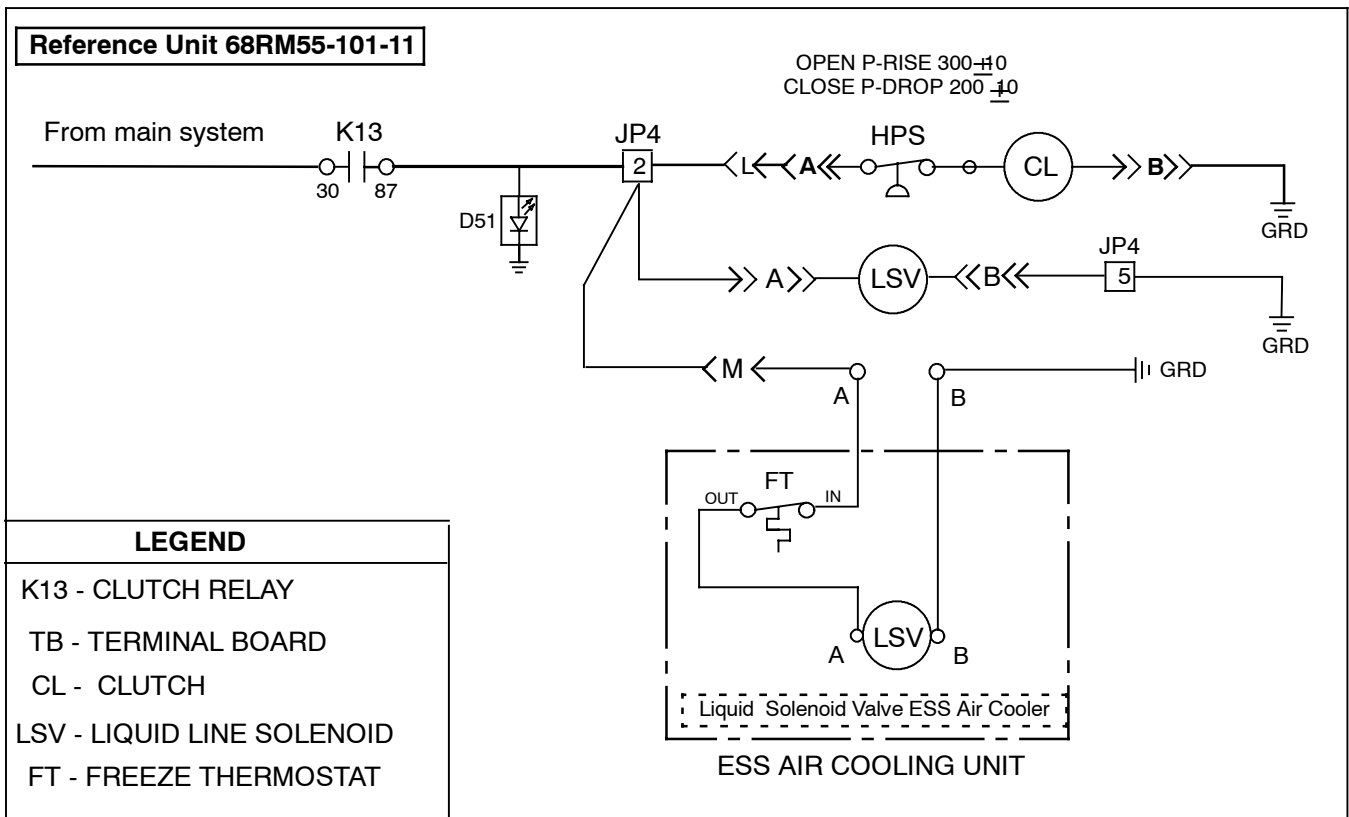

Figure 1-3 Electrical Schematic (ESS Air Cooler W/Micromax) Rearmount (RM55) Application

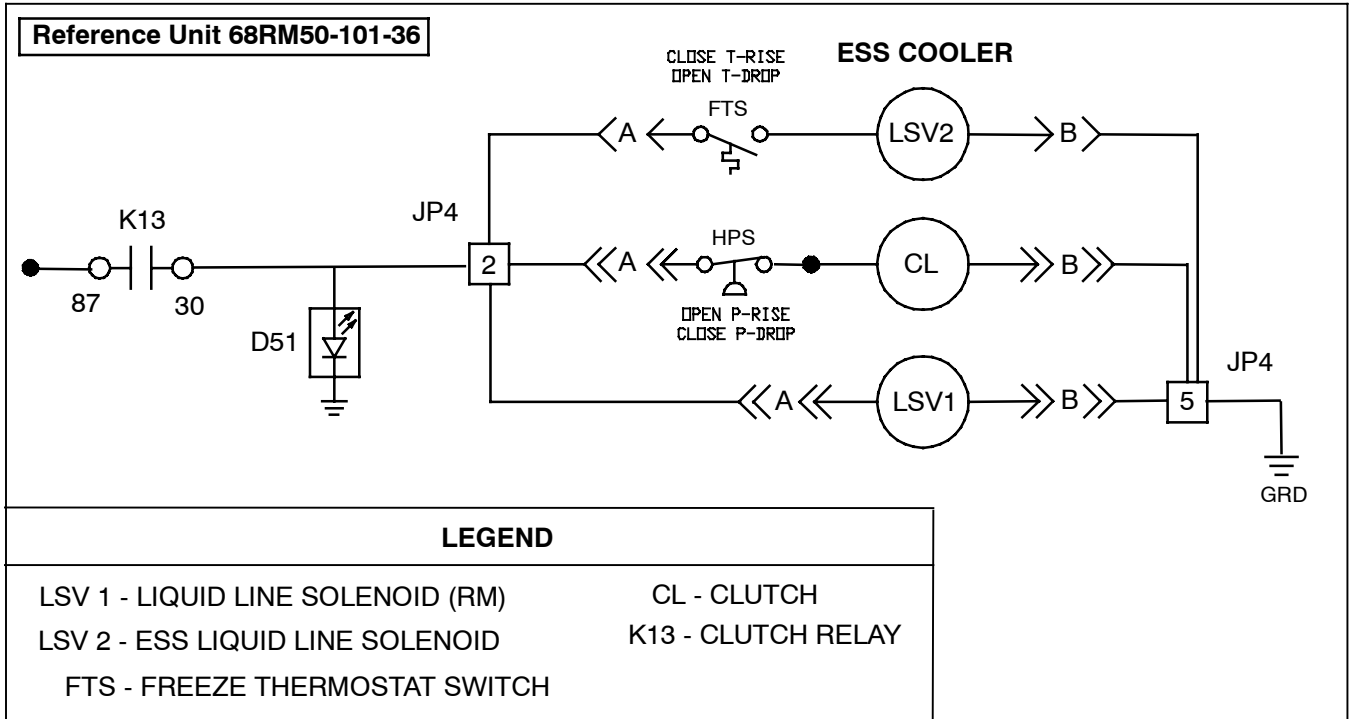

Figure 1-4 Electrical Schematic (ESS Air Cooler W/Micromax) Rearmount (RM50) Application



1.3 Installation

To install the air cooler to the ESS do the following:

- a. Remove and save six bolts (6M) from the air intake of the ESS.
- b. Remove and discard the intake grill.
- c. Remove and save six bolts (6M) from the ESS air outlet.
- d. Remove left side panel (side opposite TXV) on the Air Cooler. This will allow you access the ESS bolt holes.
- e. Place the Air Cooler against the ESS and fix in place using the original 12 (6M) ESS bolts (See Figure 1-5).
- f. Replace Air Cooler side panel.
- g. Connect a #6 or #8 liquid hose (MIO or ORS depending on application) from the main evaporator assembly to the Air Cooler TXV.
- h. Connect a #10 suction hose (MIO or ORS depending on application) from the Air Cooler TXV to the system compressor.
- i. Connect wiring from the Liquid Line Solenoid Valve on the main evaporator assembly to the Air Cooler plug.

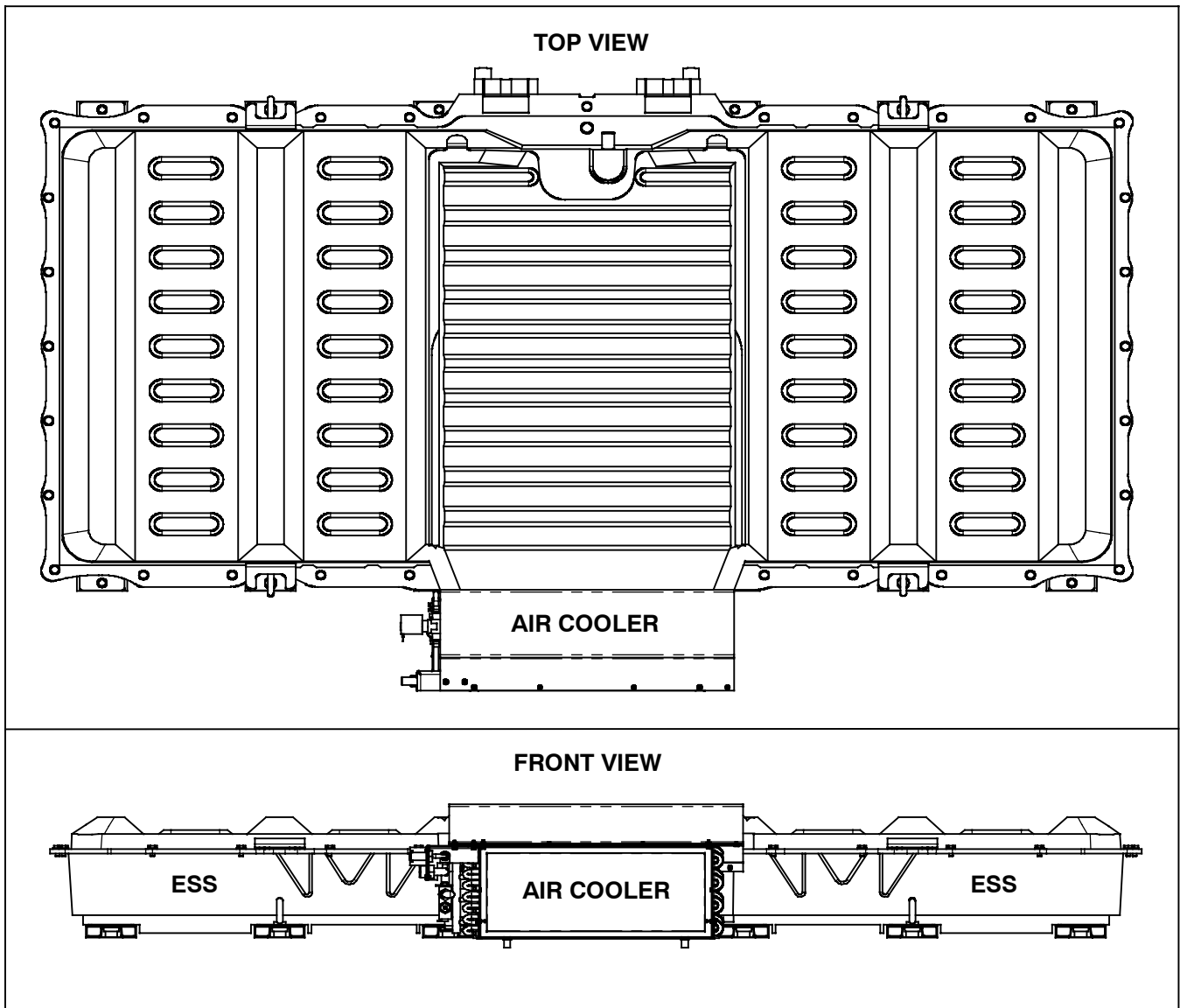

Figure 1-5 ESS With Air Cooler Installed

SECTION 2

OPERATION & SERVICE

WARNING

BE SURE TO OBSERVE ALL WARNINGS AND CAUTIONS LISTED IN THE THIS MANUAL BEFORE PERFORMING MAINTENANCE ON THE HVAC SYSTEM AND THE AIR COOLER.

WARNING

DO NOT ATTEMPT ANY SERVICE TO THE ENERGY STORAGE SYSTEM. THE ESS CONTAINS HIGH VOLTAGE AND SERIOUS INJURIES COULD OCCUR. THE CARRIER TRANSPORT AIR COOLER IS THE ONLY ITEM THAT IS SERVICABLE.

2.1 OPERATION

2.1.1 Air Circulation

The Air Cooler has no fan or blower assemblies. Circulation is achieved from the fans located within

the Energy Storage System (ESS). Ambient air is pulled across the evaporator coil and cooled. Cool air is then circulated throughout the ESS. The cool air is mixed with the heat given off from the ESS. The warm air is ejected from the ESS and returned to the ambient.

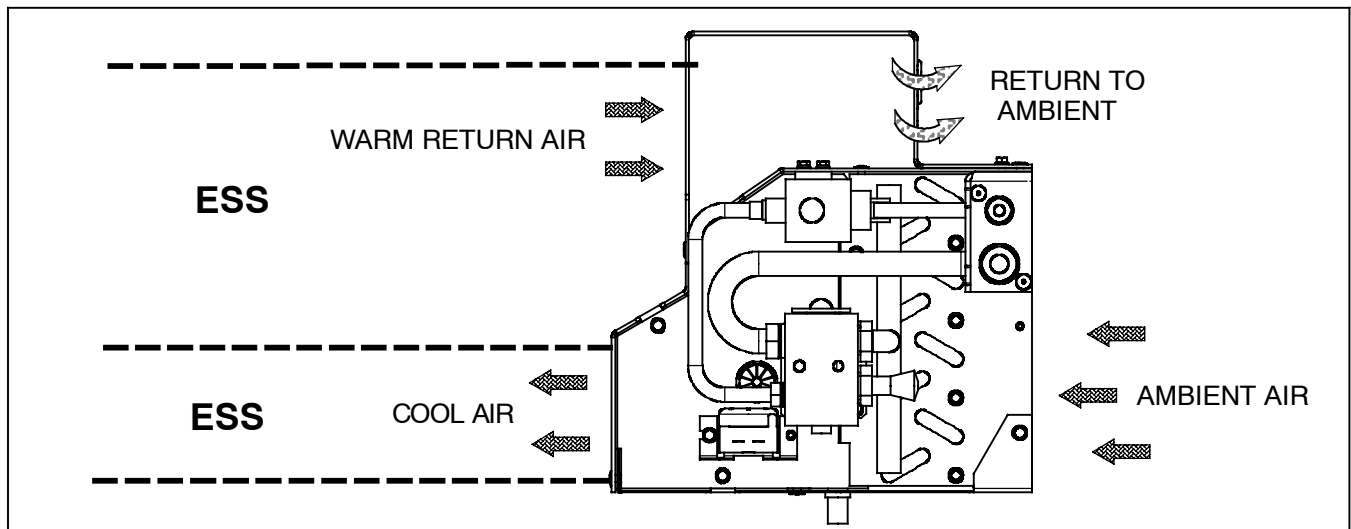

Figure 2-1 Air Cooler Operation

2.1.2 Refrigerant Cycle

The ESS Air Cooler is an auxiliary cooling component of a rooftop (RF) or rear mounted (RM) air conditioning system. When the main evaporator calls for cooling the liquid line solenoid valve is opened sending a signal to open the liquid line solenoid valve on the ESS Air Cooler (See Figure 2-2).

Liquid refrigerant flows from the main condensing assembly through the ESS Air Cooler liquid line solenoid valve to the expansion valve (TXV). The thermal expansion valve reduces pressure and temperature of the liquid and meters the flow of liquid refrigerant to the Air Cooler coil to obtain maximum use of the coils heat transfer surface.

The low pressure, low temperature liquid that flows into the Air Cooler (evaporator) coil tubes is colder



than the air that is circulated over the evaporator tubes by the ESS fans. Heat transfer is established from the evaporator air (flowing over the tubes) to the refrigerant (flowing inside the tubes). The evaporator tubes have aluminum fins to increase heat transfer from the air to the refrigerant; therefore the cooler air is circulated to the interior of the ESS. The liquid line solenoid valve closes during

shutdown to prevent refrigerant flow.

The transfer of heat from the air to the low temperature refrigerant in the evaporator coil causes the liquid to vaporize. This low temperature, low pressure vapor passes through the suction line and returns to the compressor where the cycle is repeated.

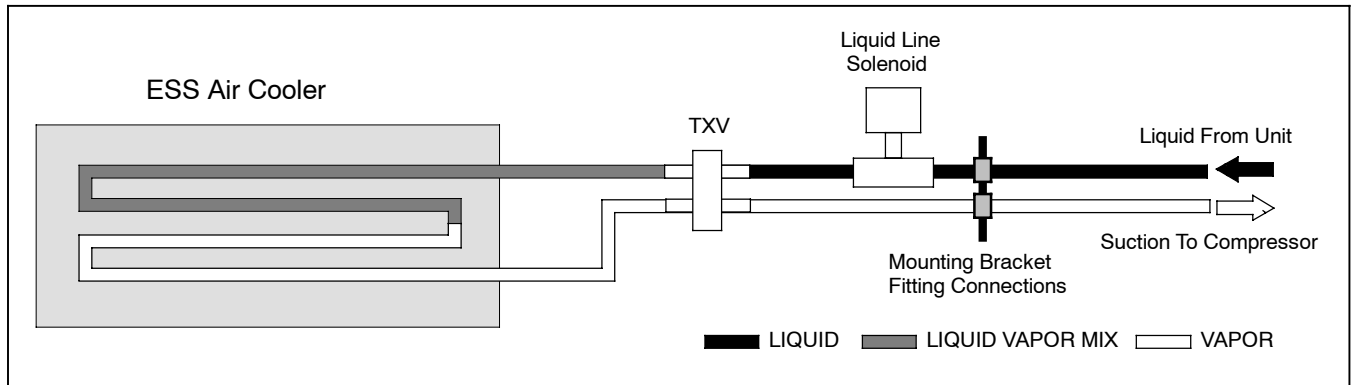

Figure 2-2 Air Cooler Refrigerant Flow Diagram

2.2 MAINTENANCE SCHEDULE

Normal or routine maintenance on the ESS Air Cooler will normally be performed in conjunction with the main rooftop (RF) or rear mounted (RM) maintenance schedules. Refer to the appropriate operation and service manual for these maintenance schedules.

2.2.1 Scheduled Maintenance

- Check inlet air filters weekly. Clean or replace as necessary.
- Check operation of the liquid line solenoid. It must operate in conjunction with the rooftop or rear mount evaporator liquid line solenoid (Refer to paragraph 2.6).
- Check liquid & suction line connections for leaks.
- Check and clean Air Cooler coil as necessary.

2.3 REFRIGERANT LEAK CHECK

A refrigerant leak check should always be performed after the system has been opened to replace or repair a component.

To check for leaks in the refrigeration system, perform the following procedure:

- Ensure liquid line solenoid valve is open. Solenoid valve will need to be powered from the closest 12VDC or 24VDC source.

Refer to the Rooftop (RF) or rear mounted (RM) service manual for procedures.

2.4 EVACUATION AND DEHYDRATION

The presence of moisture in a refrigeration system can have many undesirable effects. The most common are copper plating, acid sludge formation, “freezing-up” of metering devices by free water, and formation of acids, resulting in metal corrosion.

- Evacuate and dehydrate only after pressure leak test.

Refer to the Rooftop (RF) or rear mounted (RM) service manual for procedures.

2.5 ADDING REFRIGERANT TO SYSTEM

Refer to the Rooftop (RF) or rear mounted (RM) service manual for procedures.

2.6 SERVICING THE LIQUID LINE SOLENOID VALVE

The Liquid line solenoid valve (Figure 2-3) is very similar to a heat valve. It requires no maintenance unless a malfunction to the internal parts or coil occurs. This may be caused by foreign material such as: dirt, scale, or sludge in the refrigeration system, or improper voltage to the coil.

There are only three possible valve malfunctions: coil burnout, failure to open, or failure to close.

Coil burnout may be caused by the following:

- Improper voltage.



- 2 Continuous over-voltage, more than 10% or under-voltage of more than 15%.
- 3 Incomplete magnet circuit due to the omission of the coil hosing or plunger.
- 4 Mechanical interface with movement of plunger which may be caused by a deformed enclosing tube.

Failure to open may be caused by the following:

- 1 Coil burned out or an open circuit to coil connections.
- 2 Improper voltage.
- 3 Defective plunger or deformed valve body assembly.

Failure to close may be caused by the following:

- 1 Defective plunger or deformed valve body assembly.
- 2 Foreign material in the valve.

2.6.1 Coil Replacement

- a. It is not necessary to remove the refrigerant charge from the system.
- b. Disconnect Air Cooler from Rooftop or Rear Mounted evaporator assembly.
- c. Disconnect wire leads to coil.
- d. Remove coil retaining clip and nameplate.
- e. Lift failed coil from enclosing tube and replace.
- f. Connect wire leads, connect to main evaporator and test operation.

2.6.2 Internal Part Replacement

- a. Disconnect system from bus battery.
- b. Recover and recycle system refrigerant. Refer to the Rooftop (RF) or rear mounted (RM) service manual for procedures.
- c. Assemble valve and leak check.
- d. Evacuate and recharge system. Refer to the Rooftop (RF) or rear mounted (RM) service manual for procedures.

2.6.3 Replace Entire Valve

- a. Recover and recycle system refrigerant. Refer to the Rooftop (RF) or rear mounted (RM) service manual for procedures.
- b. Remove valve assembly from bracket.
- c. Disconnect wire leads to coil.
- d. Disassemble new valve, to protect internal parts, and solder to lines.

- e. Assemble and leak check valve. Refer to the Rooftop (RF) or rear mounted (RM) service manual for procedures.
- f. Evacuate and recharge system. Refer to the Rooftop (RF) or rear mounted (RM) service manual for procedures.
- g. Connect wire leads and test operation.

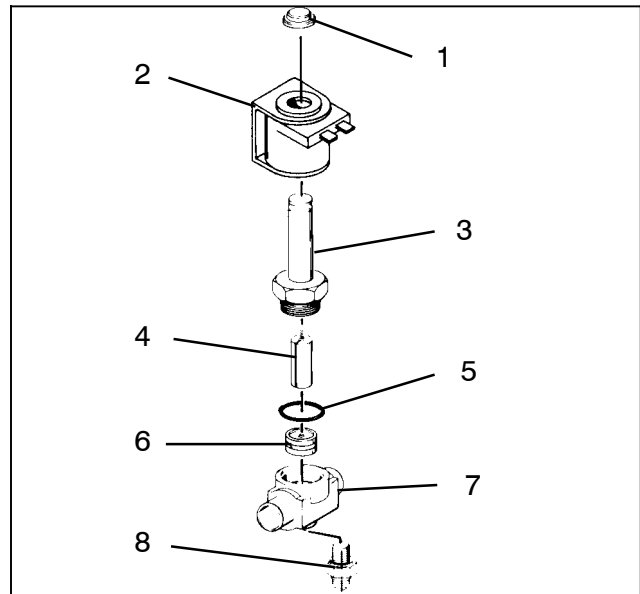

- 1 Snap Cap
- 2 Coil Assembly
- 3 Enclosing Tube Assembly
- 4 Plunger Assembly
- 5 Gasket
- 6 Piston Assembly
- 7 Body
- 8 Bracket Adapter

Figure 2-3 Liquid Line Solenoid Valve

2.7 THERMOSTATIC EXPANSION VALVE (Block)

The thermostat expansion valve is an automatic device which maintains constant superheat of the refrigerant gas leaving the evaporator regardless of suction pressure. The valve functions are: (a) automatic control of refrigerant flow to match the evaporator (Air Cooler) load and (b) prevention of liquid refrigerant entering the compressor. Unless the valve is defective, it seldom requires any maintenance.



2.7.1 Valve Replacement

- a. Recover and recycle system refrigerant. Refer to the Rooftop (RF) or rear mounted (RM) service manual for procedures.
- b. Remove no-drip insulating tape from block valve and fitting connections.
- c. Carefully loosen all fittings connected to the block valve.



There may be liquid refrigerant trapped behind the block valve. Slowly loosen the fittings and avoid contact with exposed skin or eyes.

- d. Remove and replace block valve, lubricating the fitting threads and O-rings with mineral oil before torquing to the required specification of 30/35 Ft./Lb.

NOTE

Do not attempt to adjust the replacement block valve. The valves are preset at the factory.

- e. Insulate block valve with no-drip insulating tape.
- f. Leak check, evacuate and charge system with recovered refrigerant. Refer to the Rooftop (RF) or

rear mounted (RM) service manual for procedures.

- g. Check operation of the system. Adjust refrigerant charge if needed. Refer to the Rooftop (RF) or rear mounted (RM) service manual for procedures.

2.8 COIL FREEZE THERMOSTAT (Freeze-Stat)

Freeze Thermostats are used to prevent ice from forming on the Air Cooler (evaporator) coil, which is an indication that liquid is getting back to the compressor. The Air Cooler Freeze-Thermostat is wired in series with the liquid line solenoid valve. If the Freeze-Thermostat reaches the preset temperature it will open, shutting off power to the liquid line solenoid which will also open stopping the flow of liquid refrigerant.

The Freeze-Thermostat will cut-out at 30.5° F (-0.8° C) ± 1.5° F, and it will cut-in at 45° F (7.2° C) ± 1.5° F. Preset at the factory (Non-Adjustable).

In order to accurately sense the temperature of the refrigerant within the evaporator tubes the probe of the Freeze-Thermostat must always be inserted within the evaporator coil.

2.9 HIGH PRESSURE SWITCH (Optional)

The ESS Air Cooler/Rooftop System has a normally closed High Pressure Switch wired in series with the Micromax Controller. The HPS will open when the refrigerant pressure rises to 300 Lbs. (± 10 lbs.). The HPS will close when the pressure drops to 200Lbs. (± 10 lbs.).



SECTION 3 SERVICE PARTS

INTRODUCTION

This section provides identification of service replacement parts for the Mobile Climate Control Energy Supply System (ESS) Air Cooling Units listed in the following Model Chart.

CONFIGURATION IDENTIFICATION

Unit identification information is provided on a plate (decal) located on the side of the ESS. This plate provides the unit model number and the unit serial number. The model number identifies the unit configuration and differences in detailed parts.

MODEL CHART

ESS AIR COOLER		
Model Number	Solenoid Coil Voltage (Watts)	Fitting Connections To TXV
77-62186-00	12 VDC - 15 Watts	Male Insert O-Ring (MIO)
77-62186-01	24 VDC - 15 Watts	Male Insert O-Ring (MIO)
77-62186-02	12 VDC - 15 Watts	O-Ring Seal (ORS)
77-62186-03	24 VDC - 15 Watts	O-Ring Seal (ORS)
77-62186-04	24 VDC - 15 Watts	O-Ring Seal (ORS)
77-62203-00	24 VDC - 15 Watts	O-Ring Seal (ORS)

GENERAL NOTES

To find replacement parts, determine major group in which replacement parts are located and turn to the appropriate page for the illustrated breakdown of the replacement parts. The following letter designations are used to classify parts throughout this list. Parts can be obtained by ordering from the following website:

www.mcc-hvac.com

- A/R As Required
- N/S Not Shown on Illustration
- NSS Not Sold Separately - Order next higher assembly or kit.
- P-- Suffix P-- added to part number means part is available in packaged quantity only.
- PL Purchase Locally
- SST Stainless Steel - 300 Series unless otherwise specified.
- SV Suffix SV added to part number designates service replacement part.



3.1 ESS COOLING SYSTEM 12/24V - COMMON PARTS - 77-62186-00 THRU -04

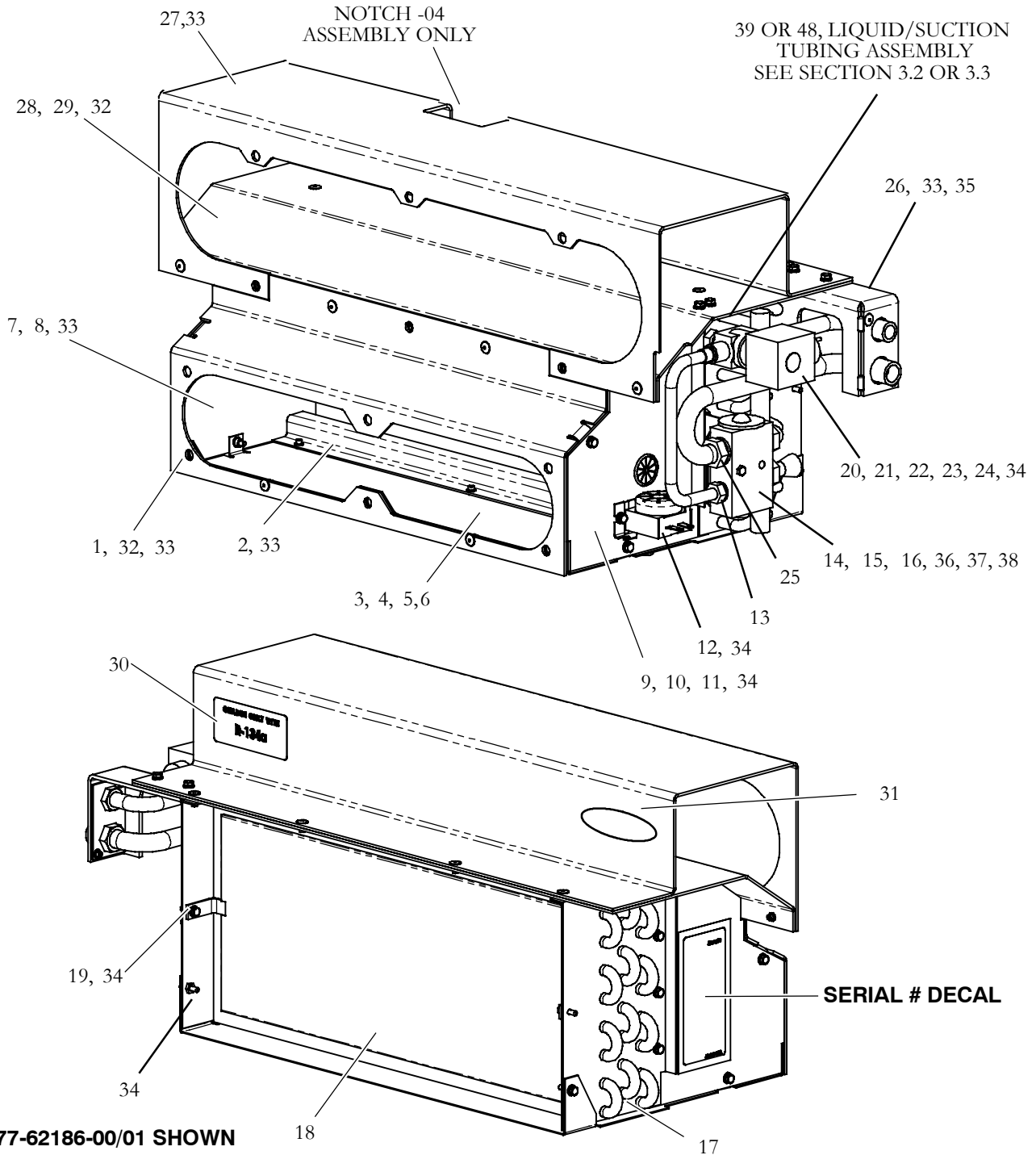

59 OR 66, HARNESS SEE SECTION 3.4 OR 3.5

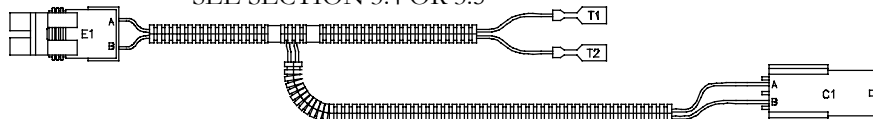



3.1 ESS COOLING SYSTEM 12/24V - COMMON PARTS - 77-62186-00 THRU -04 (Continued)			
Item	Part Number	Description	Qty
1	67-62003-00	Panel Assembly, Interface Control, White	1
2	68-63600-00	Panel, Painted	1
3	86-62438-00	Drain Pan Assembly, Painted	1
4	42-62123-00	Insulation, Baffle, Foam, Adhesive Backed	1
5	42-62125-00	Baffle, Foam	1
6	02-62000-00	Adhesive, Hot Melt D/C Tape (150 Feet Roll)	1
7	67-62002-00	Panel Assembly, Side, Interface Control, White	1
8	42-62124-00	Insulation, Side Panel, Foam, Adhesive Backed	1
9	67-62002-01	Panel Assembly, Side, Interface Control, White	1
10	42-62124-01	Insulation, Side Panel, Foam, Adhesive Backed	1
11	58-00661-04	Bushing, Plastic, 1.00 Inch Diameter Hole	1
12	12-00547-00	Thermostat, Freeze Up, Non-Adjustable, 12/24 VDC	1
13	AC801-201	O-Ring, 3/8 Inch	1
14	68-63624-00	Bracket, TXV, Painted	1
15	14-00301-03	Valve, Thermal Expansion, Block Type, R-134a	1
16	AC801-202	O-Ring, 1/2 Inch	2
17	08-62061-00	Coil Assembly, Evaporator, EM-6 - Includes:	1
	40-01124-00Body, Valve, Schrader, Brass 1/4 SAE Flare - Includes:	1
	14-00351-00Core, Valve, Schrader (Nickel Plated)	1
	DD19CA061Cap, Seal Flare 1/4 Inch	1
18	38-00573-09	Filter, Air, .012 Thick X 8.00 X 18.20 Inches	1
19	68-63578-00	Bracket, Mounting, Air Filter, Painted	2
20	67-62000-00	Bracket Assembly, Mounting, Solenoid Valve, White	1
21	22-02567-03	Coil, 12 VDC, 15 Watts (Model 77-62186-00 & -02)	1
	22-02567-02	Coil, 24 VDC, 15 Watts (Model 77-62186-01, -03 & -04)	1
22	22-01585-00SK	Connector, Male, 2 Pin, Black	1
23	22-01566-01	Terminal, Female, (18-20 AWG)	2
24	22-02394-00	Seal, Cable, Gray	2
25	AC801-203	O-Ring, 5/8 Inch	1
26	86-62440-01	Bracket, Mounting, Tube Connections, Painted (MIO)	1
	86-62440-00	Bracket, Mounting, Tube Connections, Painted (ORS)	1
27	68-63573-00	Panel, Top, Painted (Model 77-62186-00, -01, -02, -03)	1
	68-63573-01	Panel, Top, With Notch, Painted (Model 77-62186-04)	1
28	68-63572-00	Panel, Center, Painted	1
29	42-62122-00	Insulation, Center Panel, Foam, Adhesive Backed	1
30	62-02444-00	Decal, Charge Only With R-134a	1
31	56-0034	Decal, MCC Oval, 2.88 Inches	1



3.1 ESS COOLING SYSTEM 12/24V COMMON PARTS - 77-62186-00 THRU -04 (Continued)

32	42-62126-00	Insulation, Front Panel Assembly, Black, Adhesive Backed	1
33	34-62021-01	Rivet, Blind, Dome Head, 3/16 Dia., Grip Range: .250-.375	15
34	34-00917-18	Screw, Hex Head, Captive Washer, #10-32 X .50 Inch Long	18
35	34-00917-12	Screw, Hex Head, Captive Washer, #10-32 X 3/4 Inch Long	2
36	34-00655-12	Screw, Cap, Hex Head, 1/4-20 X 1-1/2 Inch Long, SST	1
37	34-00662-11	Washer, Flat, 1/4 Inch, SST	1
38	34-00667-61	Nut, Hex, Self Locking, 1/4-20, SST	1

3.2 ESS COOLING SYSTEM 12/24V MIO CONNECTIONS - 77-62186-00 AND -01

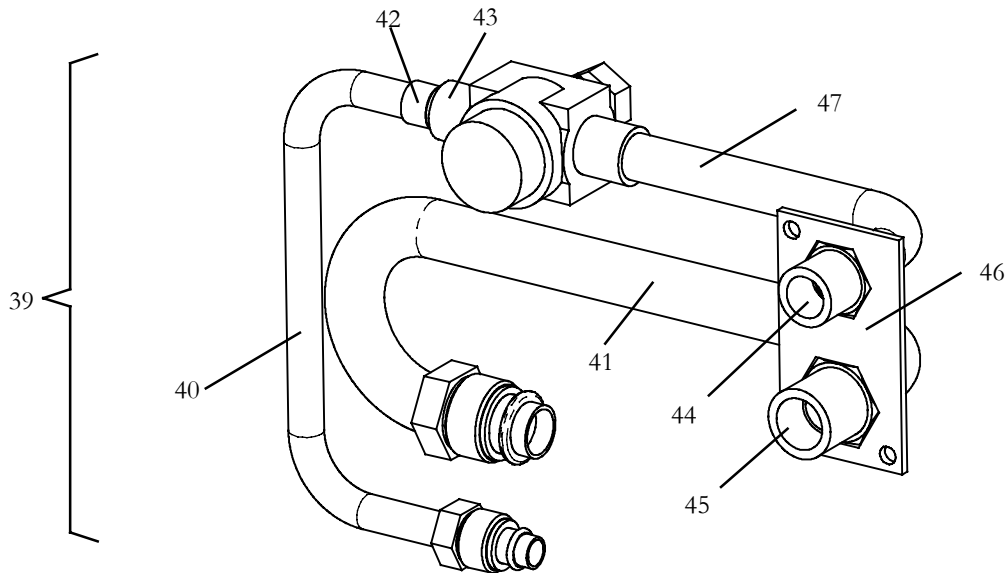

39	81-62142-00	Tube Assembly, Liquid & Suction (MIO Fittings) - Includes:	1
40	56-62299-00	Tube Assembly, Liquid, Bent, 3/8 OD X .028 Wall Copper	1
41	56-62301-00	Tube Assembly Suction, Bent, 5/8 OD X .040 Wall Copper	1
42	40-00090-04	Reducer, 1/2 ODM X 3/8 ODF, Copper	1
43	14-00150-14	Valve, Solenoid, Without Coil, 1/2 ODF (N.C.)	1
44	40-62032-02	Fitting, Swivel Nut, 1/2 X 3/4-16 M.I.O.	1
45	40-62032-01	Fitting, Swivel Nut, 5/8 X 7/8-14 M.I.O.	1
46	68-63580-00	Plate, Connection Retainer, Brass (MIO)	1
47	56-62300-00	Tube, Liquid, Bent, 1/2 OD X .035 Wall Copper	1



3.3 ESS COOLING SYSTEM 12/24V ORS CONNECTIONS - 77-62186-02, -03 AND -04

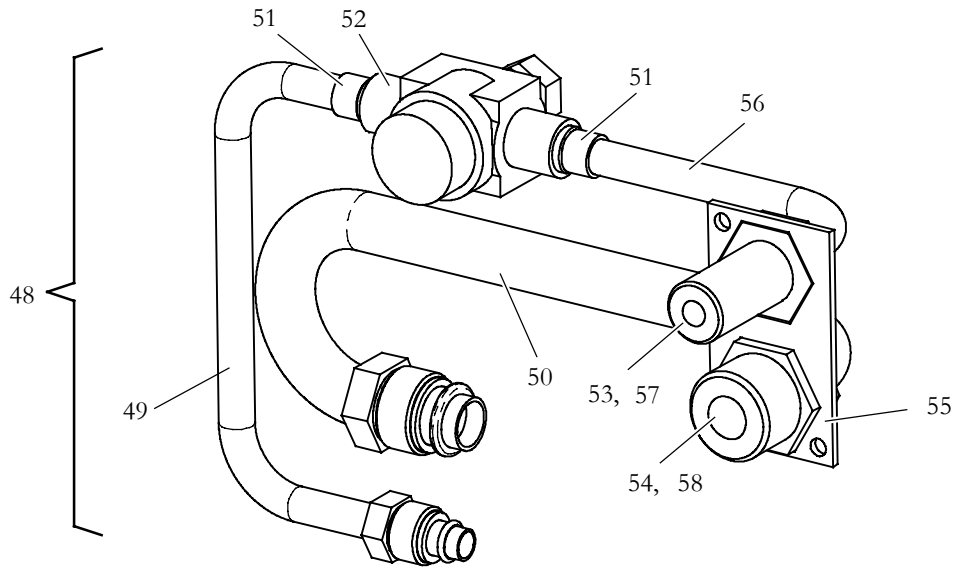

48	81-62143-00	Tube Assembly, Liquid & Suction (ORS Fittings) - Includes:	1
49	56-62299-00	Tube Assembly, Liquid, Bent, 3/8 OD X .028 Wall Copper	1
50	56-62301-00	Tube Assembly Suction, Bent, 5/8 OD X .040 Wall Copper	1
51	40-00090-04	Reducer, 1/2 ODM X 3/8 ODF, Copper	2
52	14-00150-14	Valve, Solenoid, Without Coil, 1/2 ODF (N.C.)	1
53	40-00491-12	Fitting, ORS, 3/8 X 11/16-16 (#6)	1
54	40-00491-09	Fitting, ORS, 5/8 X 1.00-14 (#10)	1
55	68-63580-00	Plate, Connection Retainer, Brass (ORS)	1
56	56-62302-00	Tube, Liquid, Bent, 3/8 OD X .028 Wall Copper	1
57	42-00243-09	O-Ring, .38 I.D. X .50 O.D.	1
58	42-00243-03	O-Ring, 0.62 I.D. x 0.75 O.D.	1



3.4 ESS COOLING SYSTEM - HARNESS 77-62186-00 THROUGH -03

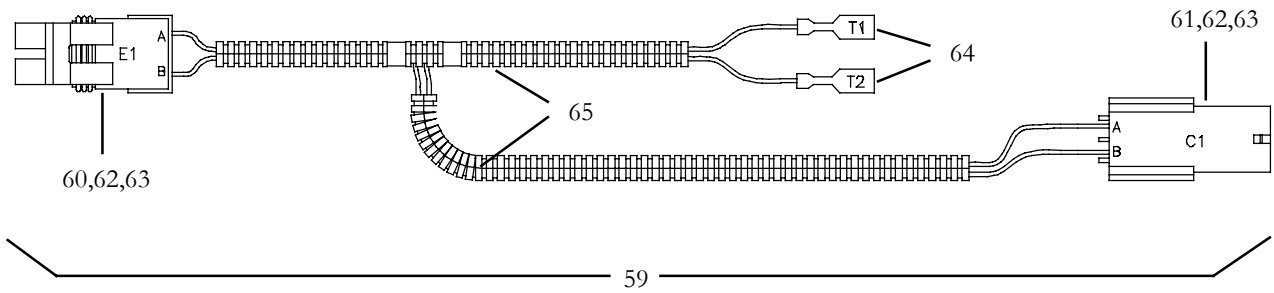

59	22-62233-00	Harness, ESS Coiling System - Includes:	1
60	22-01585-00SKConnector, Male, 2 Pin, Black (E1)	1
61	22-02392-00Connector Kit, 2 Pin (C1)	1
62	22-02393-00Terminal, Male (14-16 AWG)	4
63	22-02394-01Seal, Cable, Blue	4
64	22-01141-01Terminal, Female Slip-On, (14-16 AWG) (T1, T2)	2
65	58-04730-00F25Tube, Split, 1/4 Inch, Corrugated, Fire Retardent (25 Foot Roll)	1

3.5 ESS COOLING SYSTEM - HARNESS 77-62186-04

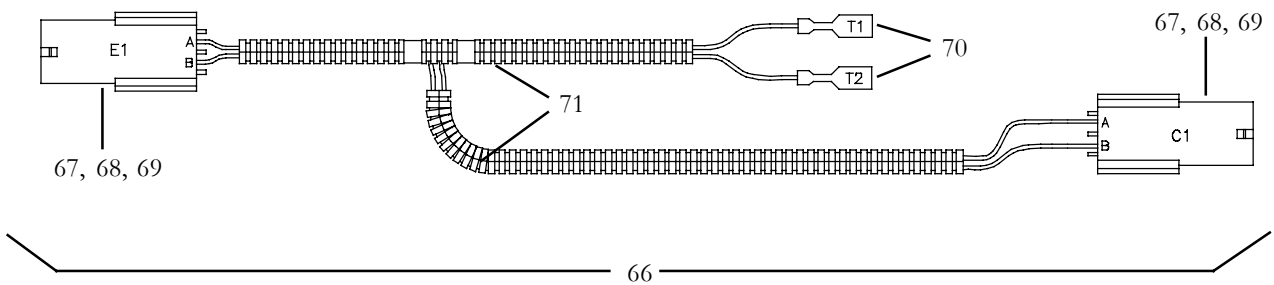

66	22-62233-01	Harness, ESS Coiling System - Includes:	1
67	22-02392-00Connector Kit, 2 Pin (C1) (E1)	2
68	22-02393-00Terminal, Male (14-16 AWG)	4
69	22-02394-01Seal, Cable, Blue	4
70	22-01141-01Terminal, Female, Slip-On, 14 AWG (T1, T2)	2
71	58-04730-00F25Tube, Split, 1/4 Inch, Corrugated, Fire Retardant (25 Feet Roll)	1



3.6 ESS COOLING SYSTEM - 24V ORS CONNECTIONS (MCI) - 77-62203-00

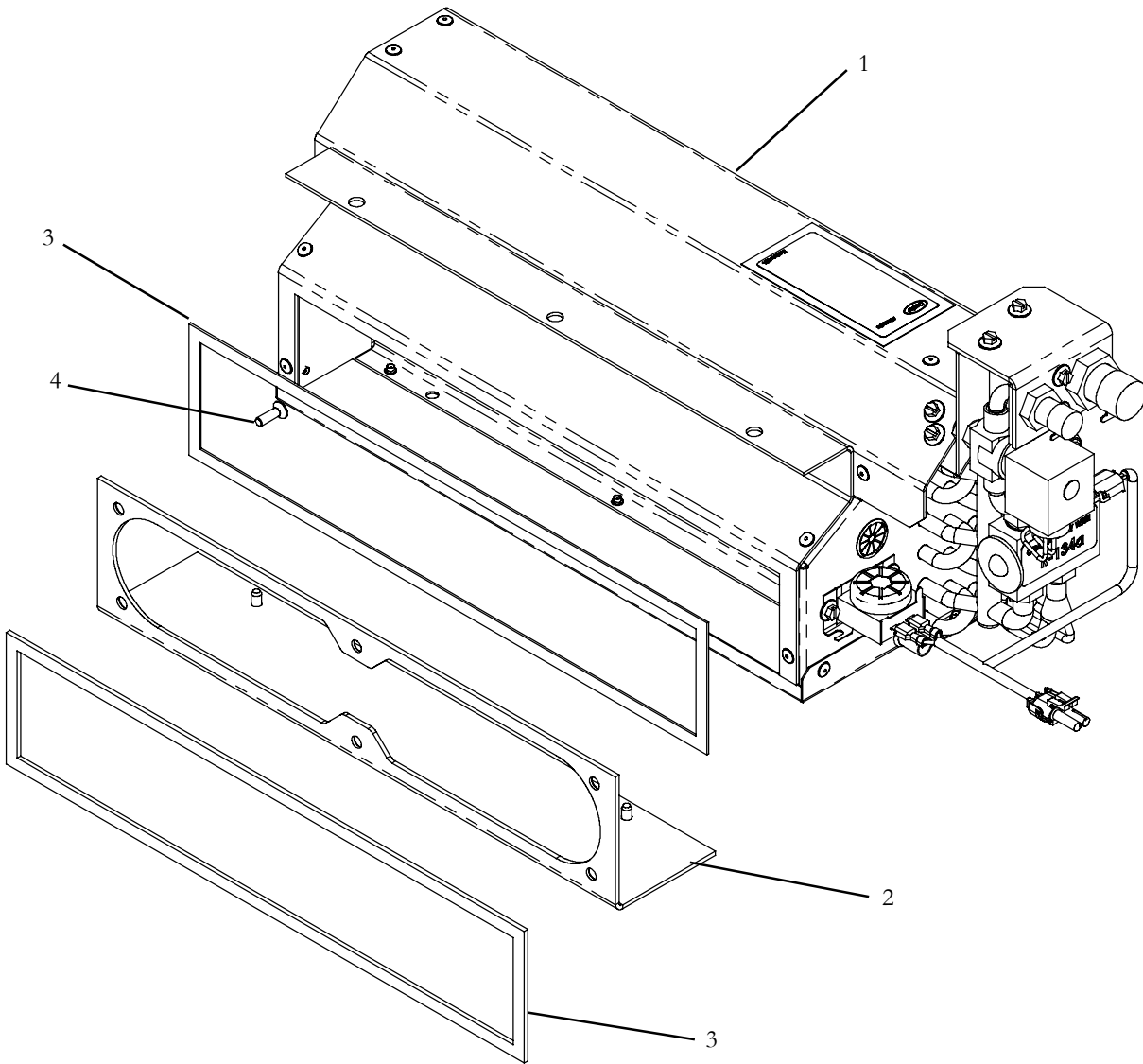

REF: 77-62203-00 (MCI)

Item	Part Number	Description	Qty
1	77-62203-01	ESS Cooling Assembly, Chassis Kit (Reference Only)	1
2	67-62021-00	Bracket Assembly, Interface Control	1
3	42-62139-00	Insulation, Bracket, Foam, Adhesive Backed	2
4	34-01267-20	Screw, Flat Head Socket, M6 x 20MM Long, Grade 10.9	6



3.6 ESS COOLING SYSTEM - 24V ORS CONNECTIONS (MCI) - 77-62203-00 - Continued

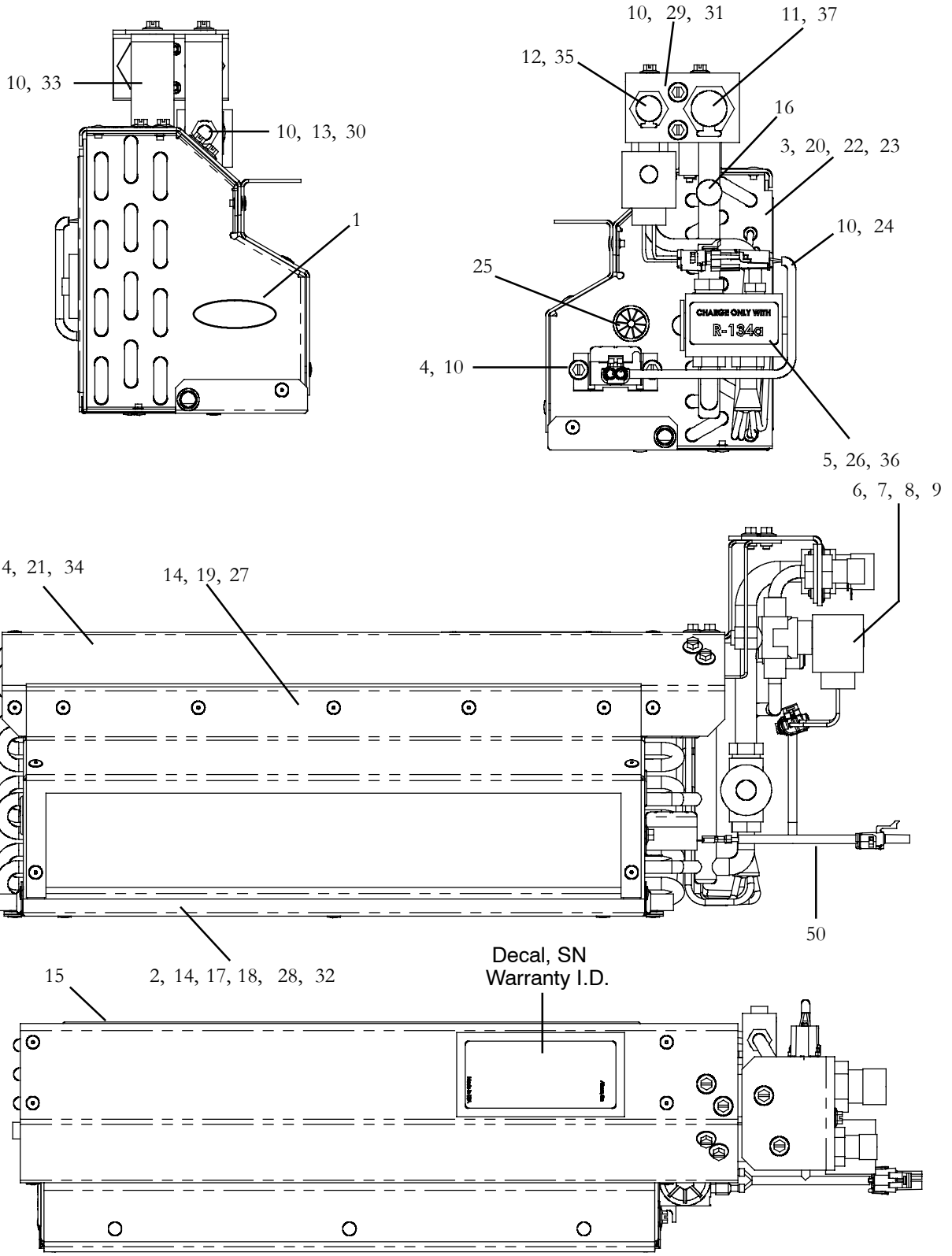

REF: 77-62203-01



3.6 ESS COOLING SYSTEM - 24V ORS CONNECTIONS (MCI) - 77-62203-00 - Continued			
Item	Part Number	Description	Qty
-	77-62203-01	ESS Cooling Assembly, Chassis Kit (Reference Only) - Includes:	-
1	56-0034	...Decal, MCC Oval, 2.88 Inches	1
2	02-62000-00	...Adhesive, Hot Melt D/C Tape (150 Feet Roll)	1
3	08-62079-00	...Coil Assembly, Evaporator, ESS Cooler	1
4	12-00547-00	...Thermostat, Freeze Up, Non-Adjustable, 12/24 VDC	1
5	14-00301-03	...Valve, Thermal Expansion, Block Type, R-134a	1
6	22-01566-01	...Terminal, Female (18-20 AWG)	2
7	22-01585-00SK	...Connector, Male, 2 Pin, Black	1
8	22-02394-00	...Seal, Cable, Gray	2
9	22-02567-02	...Coil, 24 VDC, 15 Watts	1
10	34-00917-08	...Screw, Hex Head, Captive Washer, #10-32 X .50 Inch Long	10
11	34-06088-04	...Nut, Hex, ORS, 0.625 Tube x 1.00-14 Thread, Zinc	1
12	34-06088-05	...Nut, Hex, ORS, 0.035 Tube x 11/16-16 Thread, Zinc	1
13	34-06212-15	...Washer, Plain, Type A, 7/16, SST	1
14	34-62021-01	...Rivet, Blind, Dome Head, 3/16 Dia., Grip Range: .250-.375	22
15	38-00573-09	...Filter, Air, .012 Thick X 8.00 X 18.20 Inches	1
16	40-01184-00	...Fitting Assembly, Low Side Adapter, M8 - Includes:	1
16A	40-01184-50O- Ring	1
17	42-62125-02	...Baffle, Foam	1
18	42-62131-05	...Insulation, Foam, Adhesive Backed	1
19	42-62131-06	...Insulation, Foam, Adhesive Backed	1
20	42-62131-03	...Insulation, Foam, Adhesive Backed	1
21	42-62131-07	...Insulation, Foam, Adhesive Backed	1
22	42-62138-00	...Insulation, Foam, Adhesive Backed	1
23	42-62138-01	...Insulation, Foam, Adhesive Backed	1
24	66U1-3882	...Wire Tie, Self -Locking, 7.00 Inches, Black	2
25	58-00661-04	...Bushing, Plastic, 1.00 Inch Diameter Hole	1
26	62-62039-00	...Label, Refrigerant, Charge Only With R-134a	1
27	68-63753-00	...Panel Assembly, Front, Painted	1
28	86-62520-00	...Drain Pan Assembly, Painted	1
29	68-63759-00	...Bracket, Tube Connections, Painted	1
30	67-62022-00	...Bracket Assembly, Support	1
31	67-62020-00	...Bracket Assembly, Fitting Support, Tube Connections	1
32	68-63755-00	...Panel, Painted	1
33	67-62023-00	...Bracket Assembly, Support	1
34	68-63752-00	...Panel, Center, Painted	1
35	AC801-201	...O-Ring, 3/8 Inch	1
36	AC801-202	...O-Ring, 1/2 Inch	2
37	AC801-203	...O-Ring, 5/8 Inch	1



3.7 ESS COOLING SYSTEM - SUCTION TUBE ASSEMBLY FOR 77-62203-00

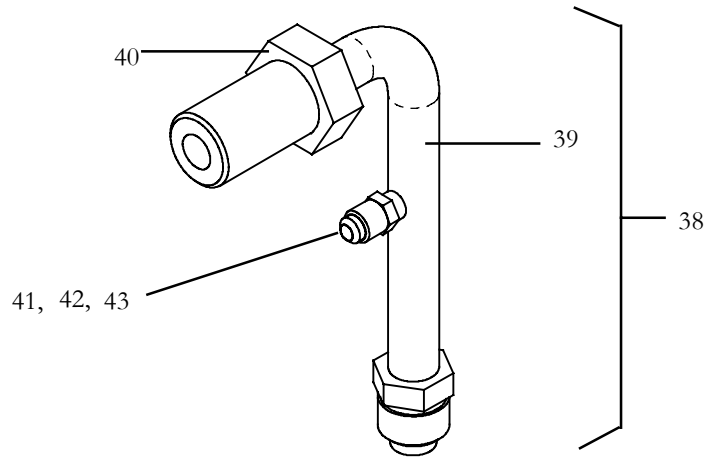

Item	Part Number	Description	Qty
38	81-62158-00	Tube Assembly, Suction - Includes:	1
39	56-62323-00	...Tube Assembly Suction, Bent, 5/8 OD X .040 Wall Copper	1
40	40-00491-15	...Fitting, ORS, 5/8 ODF X 1.00-14	1
41	40-01124-00	...Body, Valve, Schrader, Brass 1/4 SAE Flare - Includes	1
42	14-00351-00Core, Access Valve (Nickel Plated)	1
43	DD19CA061Cap, Seal, Flare, 1/4 Inch	1

3.8 ESS COOLING SYSTEM - LIQUID TUBE ASSEMBLY FOR 77-62203-00

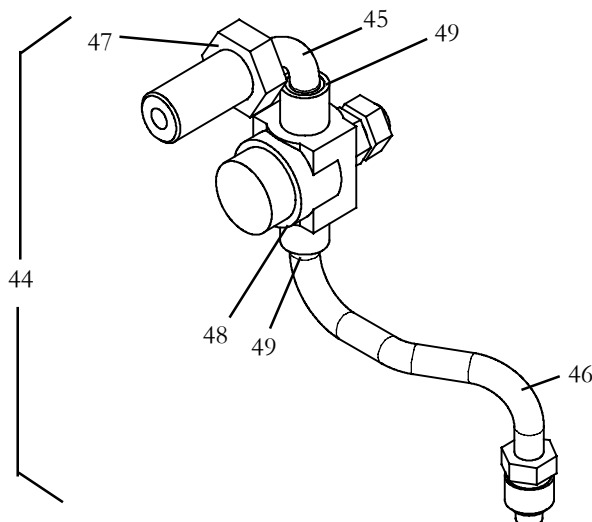

Item	Part Number	Description	Qty
44	81-62157-00	Tube Assembly, Liquid - Includes:	1
45	56-62321-00	...Tube, Liquid, Bent, 3/8 OD X .028 Wall Copper	1
46	56-62322-00	...Tube Assembly, Liquid, Bent, 3/8 OD X .028 Wall Copper	1
47	40-00491-12	...Fitting, ORS, 3/8 x 11/16-16	1
48	14-00150-14	...Valve, Solenoid, Without Coil, 1/2 ODF (N.C.)	1
49	40-00201-02	...Bushing, Tube, Flush, 1/2 ODM x 3/8 ODS	2



3.9 ESS COOLING SYSTEM - HARNESS FOR 77-62203-00 (MCI)

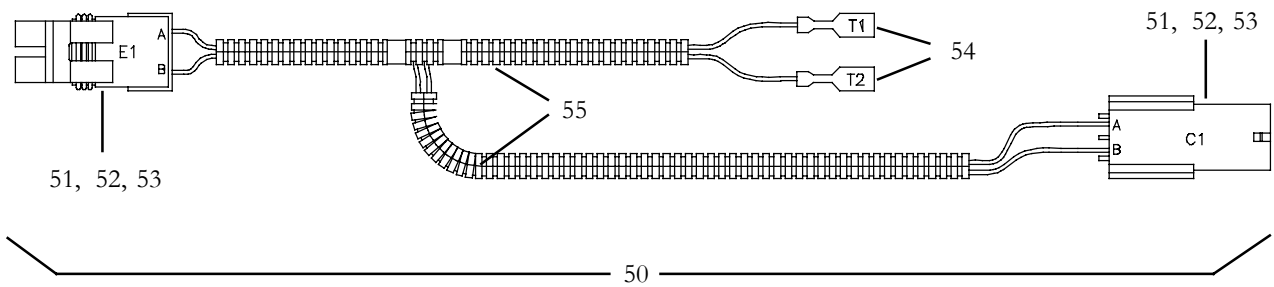

50	22-62233-01	Harness, ESS Coiling System - Includes:	1
51	22-02392-00Connector Kit, 2 Pin (C1)	2
52	22-02393-00Terminal, Male (14-16 AWG)	4
53	22-02394-01Seal, Cable, Blue	4
54	22-01141-01Terminal, Female Slip-On, (14-16 AWG) (T1, T2)	2
55	58-04730-00F25Tube, Split, 1/4 Inch, Corrugated, Fire Retardent (25 Foot Roll)	1



INDEX

PART # PAGE #

0

02-62000-00 3-3, 3-9
 08-62061-00 3-3
 08-62075-00 3-9

1

12-00547-00 3-3, 3-9
 14-00150-14 3-4, 3-5, 3-10
 14-00301-03 3-3, 3-9
 14-00351-00 3-3, 3-10

2

22-01141-01 3-6, 3-11
 22-01566-01 3-3, 3-9
 22-01585-00SK 3-3, 3-6, 3-9
 22-02392-00 3-6, 3-11
 22-02393-00 3-6, 3-11
 22-02394-00 3-3, 3-9
 22-02394-01 3-6, 3-11
 22-02567-02 3-3, 3-9
 22-02567-03 3-3
 22-62233-00 3-6
 22-62233-01 3-11

3

34-00655-12 3-4
 34-00662-11 3-4
 34-00667-61 3-4
 34-00917-08 3-9
 34-00917-12 3-4
 34-00917-18 3-4

PART # PAGE #

34-01267-20 3-7
 34-06088-04 3-9
 34-06088-05 3-9
 34-06212-15 3-9
 34-62021-01 3-4, 3-9
 38-00573-09 3-3, 3-9

4

40-00090-04 3-4, 3-5
 40-00201-02 3-10
 40-00491-09 3-5
 40-00491-12 3-5, 3-10
 40-00491-15 3-10
 40-01124-00 3-3, 3-10
 40-01184-00 3-9
 40-01184-50 3-9
 40-62032-01 3-4
 40-62032-02 3-4
 42-00243-02 3-5
 42-00243-03 3-5
 42-62122-00 3-3
 42-62123-00 3-3
 42-62124-00 3-3
 42-62124-01 3-3
 42-62125-00 3-3
 42-62125-02 3-9
 42-62126-00 3-4
 42-62131-03 3-9
 42-62131-05 3-9
 42-62131-06 3-9
 42-62131-07 3-9
 42-62138-00 3-9
 42-62138-01 3-9



INDEX

PART #	PAGE #
42-62139-00	3-7
5	
56-0034	3-3, 3-9
56-62299-00	3-4, 3-5
56-62300-00	3-4
56-62301-00	3-4, 3-5
56-62302-00	3-5
56-62321-00	3-10
56-62323-00	3-10
58-00661-04	3-3, 3-9
58-04730-00F25	3-6, 3-11

6

62-02444-00	3-3
62-62039-00	3-9
66U1-3882	3-9
67-62000-00	3-3
67-62002-00	3-3
67-62002-01	3-3
67-62003-00	3-3
67-62020-00	3-9
67-62021-00	3-7
67-62022-00	3-9
67-62023-00	3-9
67-63753-00	3-9
68-63572-00	3-3
68-63573-00	3-3
68-63578-00	3-3

PART #	PAGE #
68-63580-00	3-4, 3-5
68-63600-00	3-3
68-63624-00	3-3
68-63720-00	3-9
68-63755-00	3-9
68-63759-00	3-9

7

77-62203-01	3-7, 3-9
-------------	----------

8

81-62142-00	3-4
81-62143-00	3-5
81-62157-00	3-10
81-62158-00	3-10
86-62438-00	3-3
86-62440-00	3-3
86-62440-01	3-3
86-62520-00	3-9

A

AC801-201	3-3, 3-9
AC801-202	3-3, 3-9
AC801-203	3-3, 3-9

D

DD19CA061	3-3
-----------	-----

Every driver deserves the best possible vehicle climate with MCC products

MCC provides exceptional performance in mobile climate comfort.



www.mcc-hvac.com

Member of MCC Group • Certified ISO 9001 and ISO 1 4001.
Specifications subject to change without notice. MCC is a registered trademark.