



INSTALLATION

HYPERCHARGER AIR CLEANER

9410

PARTS INCLUDED

- 1 Hypercharger — Chrome with Drilled Back
- 1 K&N Filter Element
- 1 Mounting Kit Containing:
 - 1 Carburetor Adapter
 - 1 Carburetor Support Bracket
 - 1 Breather Adapter for Vulcan 800
 - 1 Gasket, Late Style with Adhesive
 - 2 Gasket, Late Style
 - 3 1/4"-20 x 2" Socket Head Cap Screws
 - 1 1/4"-20 x 5/8" Socket Head Cap Screw
 - 2 M6-1.0 x 16mm Hex Head Cap Screws
 - 4 1/4" Flat Washer — Chrome
 - 1 16" Length 5/32" Vacuum Hose
 - 1 6" Length 3/8" Hose
 - 1 Mini Three-Way Tee
 - 1 1/8" NPT Nipple
 - 1 3/8" Connector, Barbed
 - 1 Cap .562 ID X .69 OD X 1/2"
 - 1 Male 1/8"-27 Threaded 90° Elbow
 - 3 Hose Clamps — Stainless
- 1 Jet Kit for VN800 Including:
 - 1 Fuel Injection Needle
 - 2 E Clip for Fuel Needle
 - 3 .020 Needle Shim
 - 1 5/32" Drill Bit
 - 1 #12 X 3/4" Slotted Pan Screw
 - 1 #160 Main Jet
 - 1 #165 Main Jet
 - 1 #170 Main Jet
 - 1 #180 Main Jet
- 1 Installation Instructions

Please read and understand entire instructions before starting installation.

THANK YOU FOR CHOOSING KÜRYAKYN!

IN ORDER TO PROTECT YOU AND OTHERS FROM POSSIBLE INJURY AND/OR PROPERTY DAMAGE OR LOSS, PLEASE PAY CLOSE ATTENTION TO ALL INSTRUCTIONS, WARNINGS, CAUTIONS AND ATTENTION NOTES REGARDING THE USE AND CARE OF THIS PRODUCT.

WARNING! THIS INDICATION ALERTS YOU TO THE FACT THAT IGNORING THE CONTENTS DESCRIBED HEREIN CAN RESULT IN POTENTIAL DEATH OR SERIOUS INJURY.

ATTENTION! This indication alerts you to the fact that ignoring the contents described herein may negatively affect product performance and functionality.

CAUTION! This indication alerts you to the fact that ignoring the contents described herein can result in potential injury or material damage.

CUSTOMER SERVICE

877.370.3604 (toll free)

INSTALLATION QUESTIONS

techsupport@kuryakyn.com
or call 715.247.2983

LIMITED WARRANTY

Küryakyn warrants that any Küryakyn products sold hereunder, shall be free of defects in materials and workmanship for a period of one (1) year from the date of purchase by the consumer excepting the following provisions:

- Küryakyn shall have no obligation in the event the customer is unable to provide a receipt showing the date the customer purchased the product(s).
 - The product must be properly installed, maintained and operated under normal conditions.
 - Küryakyn makes no warranty, expressed or implied, with respect to any gold plated products.
 - Küryakyn shall not be liable for any consequential and incidental damages, including labor and paint, resulting from failure of a Küryakyn product, failure to deliver, delay in delivery, delivery in nonconforming condition, or for any breach of contract or duty between Küryakyn and a customer.
- Küryakyn products are often intended for use in specific applications. Küryakyn makes no warranty if a Küryakyn product is used in applications other than intended.
- Küryakyn electrical products are warranted for one (1) year from the date of purchase by the consumer. L.E.D.'S contained in components of Küryakyn products will be warranted for defects in materials and workmanship for 3 years from the date of purchase where as all other components shall be warranted for one(1) year. This includes, but is not limited to; control modules, wiring, chrome & other components.

• Küryakyn makes no warranty of any kind in regard to other manufacturer's products distributed by Küryakyn. Küryakyn will pass on all warranties made by the manufacturer and where possible, will expedite the claim on behalf of the customer, but ultimately, responsibility for disposition of the warranty claim lies with the manufacturer.

ABOUT OUR CATALOG

For purchasing Küryakyn® products, you can receive a complete catalog free of charge. Send the Proof-of-Purchase below with your address to: Küryakyn, P.O. Box 339, Somerset, WI 54025. Please indicate either Accessories Catalog for Harley-Davidson® or GL & Metric Cruisers.

Be sure to ask your local dealer about other Küryakyn® products, the motorcycle parts and accessories designed for riders by riders.

©2005 Küryakyn USA® All Rights reserved.



kuryakyn.com

TOOLS SUGGESTED

Set of Metric and Standard Hex Wrenches, Set of Metric Combination Wrenches, Phillips Screwdriver

Küryakyn®

STRICTLY OBSERVE THE FOLLOWING GUIDELINES IN ORDER TO USE THE PRODUCT PROPERLY AND AVOID POTENTIALLY DANGEROUS ACCIDENTS.

STEP 1 Read and understand all steps in the instructions before starting the installation. Park the motorcycle on a hard, level surface and turn off the ignition. Let cool.

DISCLAIMER — PLEASE READ BEFORE PROCEEDING

Any modifications to a motorcycle's exhaust or intake tract require carburetor re-jetting to achieve maximum performance and maintain drivability. If you are uncomfortable with the process of tuning your carburetor, we recommend that you bring your motorcycle to a qualified motorcycle mechanic to have this kit installed. The jets included in this kit were selected based on test results with various combinations of components that we felt would represent the majority of the customers purchasing this kit. However, no two motorcycles are exactly alike. Depending on the individual case, additional jets may need to be purchased from an outside source. Küryakyn warrants the parts included in this kit to be free of defects in materials and workmanship, but makes no claim whatsoever in regard to costs associated with installation or tuning.

WARNING! YOU WILL BE WORKING AROUND THE ENGINE AND EXHAUST SYSTEM DURING INSTALLATION. ENSURE THAT THE ENGINE AND EXHAUST SYSTEM HAVE FULLY COOLED TO PREVENT INJURY.

ATTENTION! A factory service manual may be helpful in performing this installation. Do not attempt to perform this installation if you are not confident in your ability to complete all of the steps in the procedure; consult a trained technician.

CAUTION! The installation of any high performance exhaust system can cause a "lean" fuel/air mixture. A "lean" fuel/air mixture can cause engine overheating resulting in severe engine damage. Küryakyn recommends re-jetting carbureted bikes.

STEP 2 Remove the seat from the motorcycle.

STEP 3 Remove the dash from the fuel tank. You will have to unplug two plugs, and unscrew the speedometer cable from the speedometer head.

STEP 4 Make sure the fuel petcock is closed. Remove the fuel line and vacuum line from the petcock and the vent hoses from the fuel tank. Remove the fuel tank mounting bolts and remove the tank from the motorcycle.

STEP 5 Remove the air box from the bike. See PIC.1.

STEP 6 Remove the chrome air cleaner cover, filter, and backing plate from the bike. See PIC.2.

STEP 7 Remove the hoses shown in PIC.3 from the rear of the stock air cleaner. Insert the vinyl cap onto the end of the largest hose (fresh air induction).

STEP 8 Remove the stock air cleaner support bracket. Set it and its fasteners aside as they will be reused. See PIC.4.

STEP 9 Using a hex wrench, loosen the clamp that secures the carb spigot to the intake manifold.

STEP 10 See PIC.5. Remove the vacuum line, float bowl vent, fuel line, throttle control cables, and enrichener control from the carburetor.

-cont.-

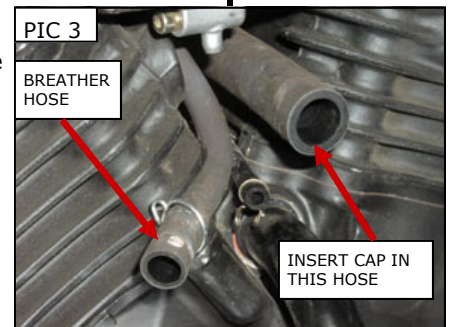
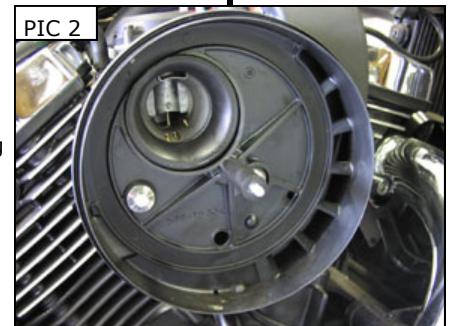

PAGE

2

HYPERCHARGER

INSTALLATION

STEP 11 Pull the carb free of the manifold and remove it from the motorcycle. Install the Jet Kit provided.

NOTE: Now is a good time to proceed with re-jetting of the carburetors. Consult your factory service manual for this procedure. We have supplied jets to cover most common applications.

CARBURETOR RE-JETTING PROCEDURE

NOTE: Different combinations of aftermarket exhaust and air cleaners will have a significant impact on carburetor jetting. The supplied jetting components have been tested and found to be a good combination to produce drivability and performance with stock or free flowing, muffled/baffled exhaust pipes. We highly recommend NOT using drag pipes (open style). Using drag pipes in conjunction with our air cleaner may require additional jetting above and beyond the components included in this kit.

- A) Carefully drain all gas from the carburetor.
- B) See FIG.1. Set the carburetor on its top with the float bowl facing upwards. Observe the cylindrical casting to the rear of the float bowl. Notice the brass plug in the end of that casting. Use a center punch to make a divot in the end of this plug. Using the supplied drill bit carefully drill out the center of the plug. **IMPORTANT:** Located below the plug is a brass adjustment screw. Be extremely careful not to allow the drill bit to break through the plug and damage the screw below. Start the supplied slotted pan screw with pliers and gently wiggle the screw back and fourth while pulling outward to remove the plug. Turn the adjustment screw all the way in until it lightly bottoms out. Back the adjustment screw out 3-1/2 turns from bottomed.
- C) Carefully remove the float bowl. The stock #48 low speed jet is located in the deep cylindrical recess. Remove and replace the main jet with one of the following:
 - #160 – Used in high elevations and/or with stock or restrictive exhaust
 - #165 – Used with baffled drag pipes (like the Vance & Hines Straight Shots)
 - #170 – Muffled performance pipes (like Cobra or Vance & Hines Duals)
 - #180 – Open drag pipes
- D) Replace the float bowl.
- E) Carefully remove the carburetor top, slide spring, and slide. The rubber diaphragm is very fragile. **Use caution not to tear, puncture or stretch it.** The needle can be addressed one of two ways.
 - 1) The stock needle works well when installed with the three supplied needle shims placed under the head of the needle, raising the installed position of the needle.
 - 2) The supplied needle may also be installed providing further adjustment if additional performance modifications will be made.
- F) Once your choice of needle has been installed, Replace the nylon needle retainer, slide, and slide spring.
- G) Carefully place the lip of the diaphragm into the groove in the top of the carburetor body and install the carburetor top. **IMPORTANT:** Be sure the diaphragm has not been pinched or damaged in any way during installation. **ANY** leak in this seal will cause the bike to run poorly and will require replacement of the diaphragm.

CARBURETOR TUNING TIPS

Several factors can influence the tuning and drivability of your motorcycle. Altitude, temperature, and choice of exhaust will all affect performance. Further adjustments may be required based on these factors. Backfires through the intake generally indicate a lean condition. Blubbering, shuddering, smoking and plug fouling indicate a rich condition. If jet changes are required be certain that you change the jet causing the problem. **EXAMPLE:** If your bike exhibits a cough or backfire through the intake, changing the main jet would not change the condition.

-cont.-

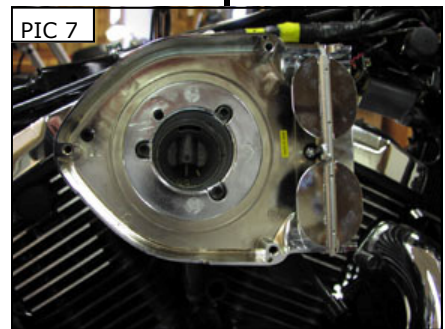
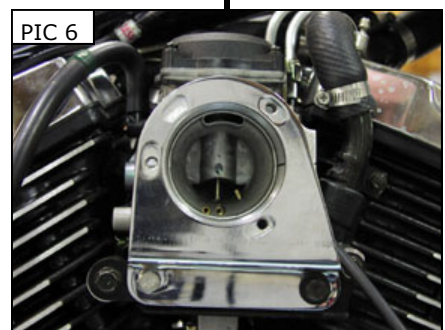
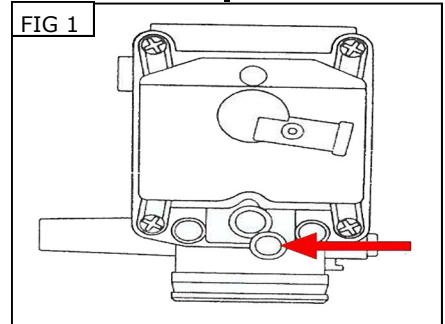
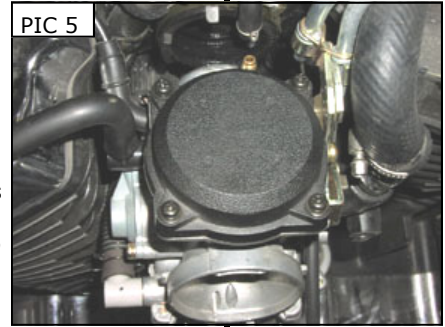
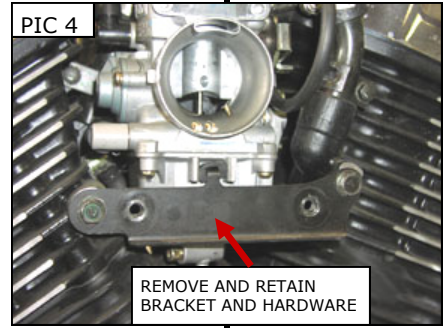

- From idle to 1/8 throttle is controlled by the idle mixture screw
- Just off idle to 1/4 throttle is controlled by the low speed jet
- 1/4 throttle to 3/4 throttle is controlled by the needle and needle jet
- 3/4 throttle to wide open is controlled by the main jet

STEP 12 Reinstall the carb on the manifold, and re-connect all hoses, cables etc. Tighten the intake manifold clamp.

STEP 13 Reinstall the stock carb support bracket.

STEP 14 Install the billet aluminum carburetor adapter on the mouth of the carburetor. The adapter's slot should be in the 3 o'clock position with the pinch bolt installed from the top. Do not tighten the pinch bolt at this time. Install the peel and stick gasket to the exposed surface of the adapter.

STEP 15 Install the chrome carb support bracket using the M6-1.0 x 15mm hex head cap screws provided. (PIC.6). If there is a gap between the stock air cleaner mounting bracket and the new carb support, shim with the supplied 1/4" flat washers. In some cases it may be necessary to slightly bend the stock bracket so the carb support will lay flat against the adapter when the M6 screws are tightened.

STEP 16 Install the 1/8" NPT x 3/8" O.D. nipple in the threaded hole in the bottom of the breather adapter.

STEP 17 Remove the trap door from the front with a 1/8" hex key, remove the trap door on the front of the Hypercharger. Install the Hypercharger and breather adapter as one unit. The three 1/4"-20 x 2" socket head cap screws will go through the back of the Hypercharger, the breather adapter, and the carb support then thread into the carb adapter. Be sure to install gaskets between the Hypercharger and breather adapter and the breather adapter and support bracket. The breather nipple should point downward. Note that one of the four holes in the Hypercharger will not be used - it is a vent hole for H-D applications. See PIC.7 (In PIC.7 we have removed the front of the Hypercharger and the filter for clarity. You need only remove the trap door.) Adjust the Hypercharger so it is horizontal before tightening the 1/4"-20 x 2" screws. Reinstall the trap door and securely tighten the adapter pinch bolt.

STEP 18 Insert the 3/8" barbed connector into the breather hose (PIC.3) and add the 6" length of 3/8" I.D. hose included in the kit. Plug the extended breather hose onto the breather adapter's nipple. Secure all connections with the hose clamps provided (PIC.8).

STEP 19 **VERY IMPORTANT!** Install the plastic 90° elbow in the threaded hole on the back of the Hypercharger. The stock float bowl vent hose is routed from the carb back to a "dead end" location under the seat. Pull this hose free from under the seat, but leave it connected to the carb fitting. Run this hose from the carb down to the 90° fitting on the back of the Hypercharger, cut it to length, and connect it to the fitting. See PIC.9.

STEP 20 See PIC.10. Locate the vacuum line going to the fuel petcock. At a convenient location, cut the line and install the "T" as shown. Install the supplied length of vacuum hose to the "T" and connect the remaining end to the vacuum nipple on the bottom of the Hypercharger. (The butterflies will be wide open when the bike is off, or at full throttle, and mostly closed when the bike is at idle.

STEP 21 Re-install the tank, dash, and seat in the same manner it was removed.

STEP 22 **Double check the tightness of all related fasteners, check for hose clearance and check throttle for correct operation, making sure it returns properly, before starting the bike.**

ATTENTION! It is the installer's responsibility to ensure that all of the fasteners (including preassembled) are tightened before operation of the motorcycle. Küryakyn will not warranty components lost due to improper installation. Periodic maintenance may be required.

