



BVM

CORPORATION
USA



Maintenance Manual
350 Ton - 500 Ton
4 1/2" to 14" Spider / Elevator



**SERVICE MANUAL
350/500 TON CASING ELEVATOR/SPIDER
FOR 4 ½ IN. THRU 14 IN. O.D. CASING**

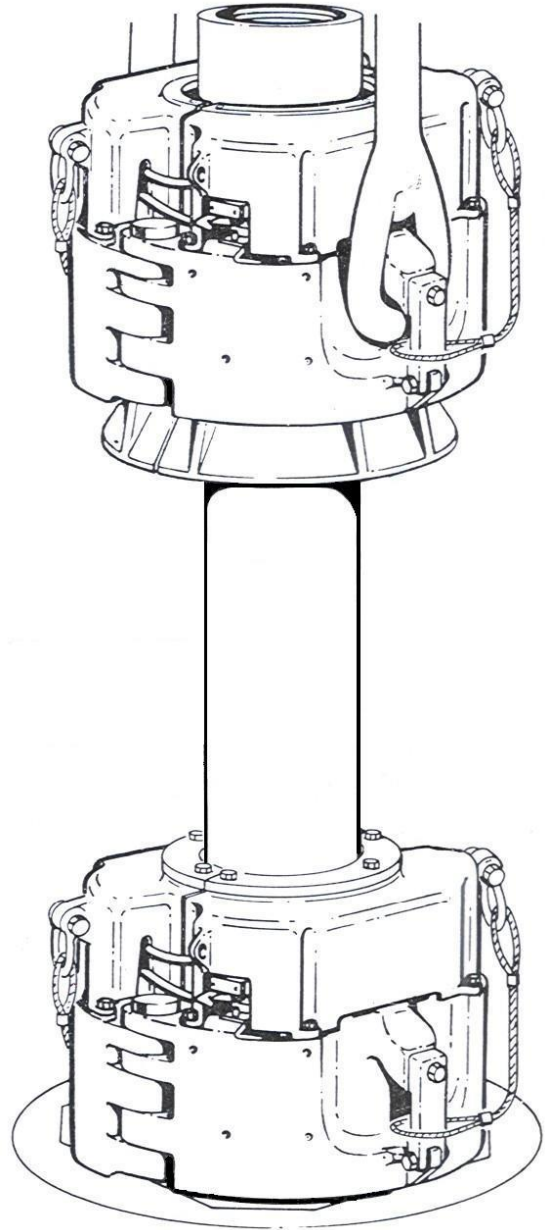

**BVM CORPORATION
430 S. Navajo St.
Denver, CO 80223
Phone: 303-975-1402
Fax: 303-975-0981
E-Mail: sales@bvmcorp.com**

TABLE OF CONTENTS

<u>Section No</u>	<u>Page</u>
I	DESCRIPTION
	1-1. Introduction..... 3
	1-2. Description 3
	1-3. Theory of Operation 3
	1-4. Specification 4
II	INSTALLATION 5
	2-1. Introduction..... 5
	2-2. Installation Preparation. .. 5
	2-3. Spider Installation..... 5
	2-4. Elevator Installation 5
	2-5. Regulator/Filter and Hose Installation..... 6
III	OPERATION..... 8
	3-1. Operation..... 8
	3-2. Running Casing..... 8
	3-3. Changing Slips 8
	3-4. Changing Elevator Bottom Guide 9
	3-5. Changing Spider Top Guide.... 9
IV	MAINTENANCE 11
	4-1. Lubrication..... 11
	4-2. Regulator/Filter Maintenance 11
	4-3. Lubricator Maintenance .. 11
V	DISASSEMBLY & ASSEMBLY 12
	5-1. Dissassembly and Inspection 12
	5-2. Assembly..... 15
VI	ILLUSTRATED PARTS LISTS 17
	6-1. Introduction..... 17
	6-2. Description of the List System 17

LIST OF TABLES

<u>Table No</u>	<u>Title</u>	<u>Page</u>
1-1.	Specifications	4
3-1.	500 Ton Elevator/Spider and Component Part Numbers.....	10
4-1.	Trouble Shooting	11
4-2.	Lubrication Schedule.....	12
5-1.	Inspection of Elevator/Spider	13
5-2.	Inspection of Air Cylinder	14
5-3.	Inspection of Control Valve	14
6-1.	350 Ton Elevator/Spider Parts List Index.....	20
6-2.	500 Ton Elevator/Spider Parts List Index.....	24
6-3.	Air Cylinder Parts List Index.....	26
6-4.	Valve and Latch Parts List Index..	28
6-5.	Air Inlet Parts List Index	29
6-6.	Valve Parts List Index.....	29

LIST OF ILLUSTRATIONS

<u>Figure No.</u>	<u>Title</u>	<u>Page</u>
1-1.	Elevator and Spider.....	3
1-2.	Elevator/Spider Dimensions	4
2-1.	Elevator and Spider Installed	5
2-2.	Elevator/Spider Installation.....	6
2-3.	Regulator/Filter and Hose Installation ..	7
3-1.	Changing Slips	8
3-2.	Elevator Bottom Guide Installation.....	9
4-1.	Lubrication Points.....	12
6-1.	500 Ton Elevator/Spider Assembly....	22
6-2.	Air Cylinder Assembly	26
6-3.	Valve and Latch Assembly.....	27
6-4.	Air Inlet Assembly.....	29
6-5.	Valve Assembly.....	30

SECTION I

DESCRIPTION

1-1. INTRODUCTION

The BVM 350 and 500 Ton Casing Elevator/Spider units are pneumatically-operated power tools capable of handling casing sizes up to 14 inches. The 350 ton unit has a capacity of 700,000 pounds and 1,000,000 pounds for the 500 ton.

1-2. DESCRIPTION

The main body of these units can be dressed as a casing elevator or spider. The upper unit is dressed as an elevator, using a bottom guide and a bell guide. The lower unit is dressed as a spider, using a top guide to aid in centering the casing.

The elevator is attached to the derrick traveling block and hook with 350 or 500 ton standard API links. The spider can be located directly on the master bushing (with the insert bowls removed). If the rated load capacity of the rotary table does *not* exceed the capacity of the elevator/spider unit, or if the rotary table surface is not flat, an adaptor plate may be used.

1-3. THEORY OF OPERATION

Air pressure (70 to 125 psi) applied to the cylinders when the control lever is actuated, picks up a fine oil mist in the lubricator. The oil serves to keep the cylinder lubricated. When the control lever is moved, air pressure in the cylinders causes the leveling beams to change position – moving up to release, or down to set.

When the control lever is moved down, the four slips are lowered into the tapered bowl and forced inward radially to center

and grip the casing. When set; the slips hold casing securely, without damage.

The direct air lift and lock mechanism enables instant actuation of the slips. In offshore or land operations this allows the rig hands to raise and lock, or lower and set the slips instantly.

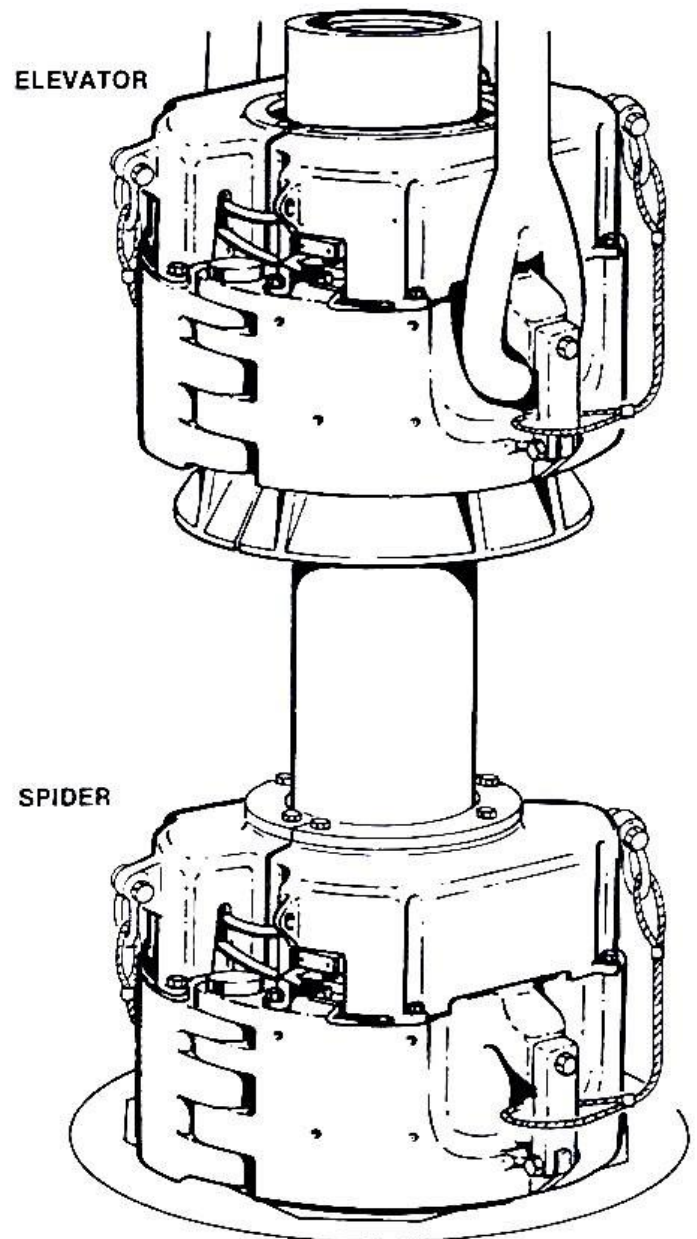

Figure 1-1. Elevator and Spider (500 Ton Shown)

1-4. SPECIFICATIONS

Table 1-1. Specifications

	350		500	
	English	Metric	English	Metric
Casing Size Range	4 1/2 thru 14 in	114 thru 365 mm	4 1/2 thru 14 in	114 thru 365 mm
Max. Safe Hook Load	700,000 lbs	317,518 kg	1,000,000 lbs	455,000 kg
Approximate Weight				
Elevator/spider (Less Guides and Slips)	3,900 lbs	1,769 kg	5,000 lbs	2,268 kg
Bell Guide Kit	400 lbs	181 kg	400 lbs	181 kg
Adaptor Plate	700 lbs	318 kg	700 lbs	318 kg
Operating Pressure				
Normal	70 to 80 psi, 483 to 552 kpa			
Maximum	125 psi, 861 kpa			
Approximate Cycle Time				
To Set Slips	One Second			
To Release Slips	Two Seconds			

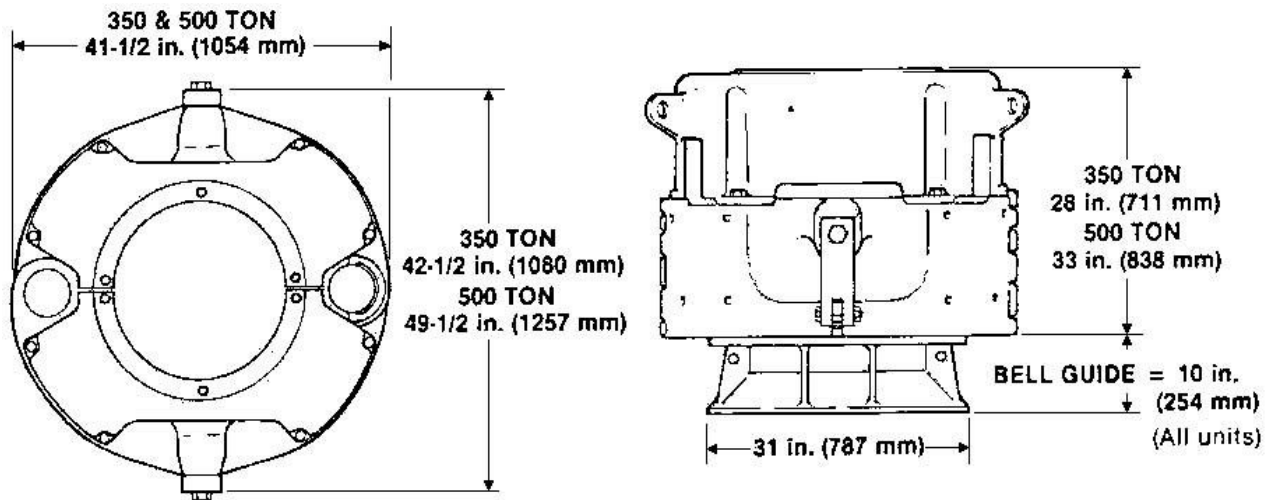

Figure 1-2. Elevator/Spider Dimensions

SECTION II

INSTALLATION

2-1. INTRODUCTION

The elevator/spider units are shipped as illustrated in Figure 2-1. A specified set of slip segments and guide rings are shipped installed.

NOTE

The slip set and guide rings must correspond to casing diameter or damage to slips and casing will result (see Table 3-1 or 3-2).

2-2. INSTALLATION PREPARATION

Clean, dry air, filtered and regulated to 70 to 125 psi is required to operate these units.

2-3. SPIDER INSTALLATION

NOTE

If an adapter plate is used, check to be certain it is level, so the spider will be in line with the bore hole. Install the adapter plate with centering lugs facing up. These stops help to keep the spider centered. If an adapter plate is not used, check with rotary table manufacturer to be certain it will support spider unit.

- Hoist spider into position over bore hole.
- Lubricate as indicated on Page 13 (Figure 4-1).
- Connect air lines (Paragraph 2-5).

2-4. ELEVATOR INSTALLATION

NOTE

Be certain links and rig hook are capable of supporting the load indicated on the body of the unit (350 or 500 Tons).

- Open elevator link retainers and slide the bottom eyes of the links capable of

- supporting the maximum limit of the elevator, over the lifting lugs.
- Close and secure link retainers.

NOTE

Be certain the elevator control handle is on the side faces the stabbing board, so that the derrick man will have access to it.

- Lubricate as indicated on page 13 (Figure 4-1).
- Connect air line (Paragraph 2-5).

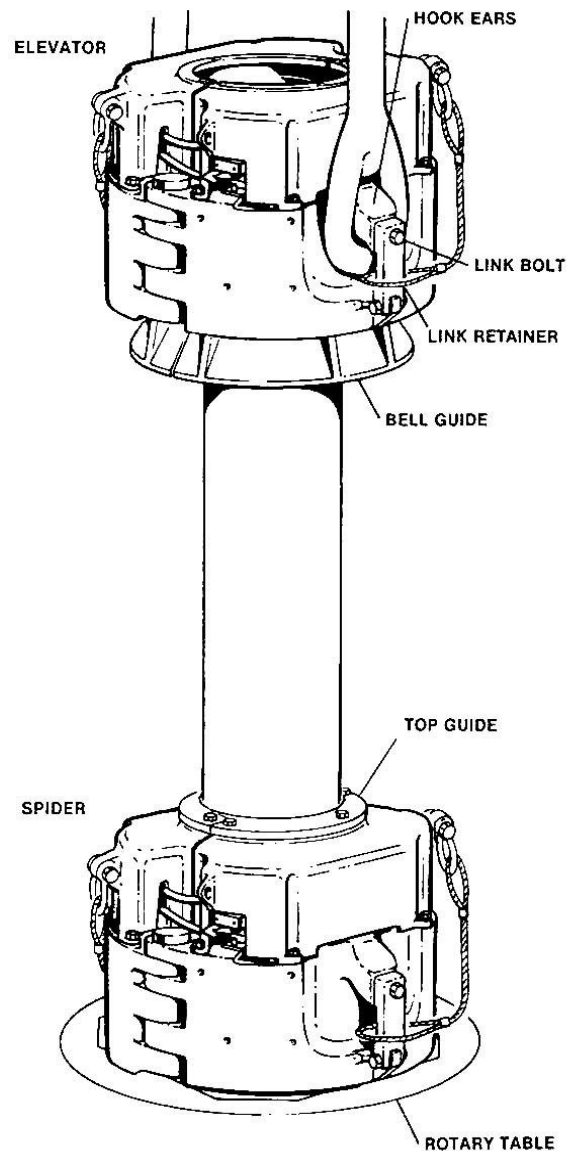

Figure 2-1. Elevator and Spider Installed

2-5. REGULATOR/FILTER AND HOSE INSTALLATION

A shutoff valve should be installed on the end of the pipe before installing the regulator/filter. This valve will serve to cut off the air supply in the event that maintenance must be performed on the system.

1. Mount the regulator/filter near the air supply line, in an area that allows easy access for service.

2. Close the shutoff valve. Connect the regulator/filter to the shutoff valve.
3. Run one 50-foot section of air hose up the derrick. Trying to prevent damage and keep it clear of the working area. Connect a second 50-foot section to the first and connect its other end to the elevator.
4. Connect a 25-foot section of air hose to the regulator/filter and the spider.
5. Open the shutoff valve on the air supply line and adjust the regulator to deliver 70 to 80 psi to the elevator and spider.

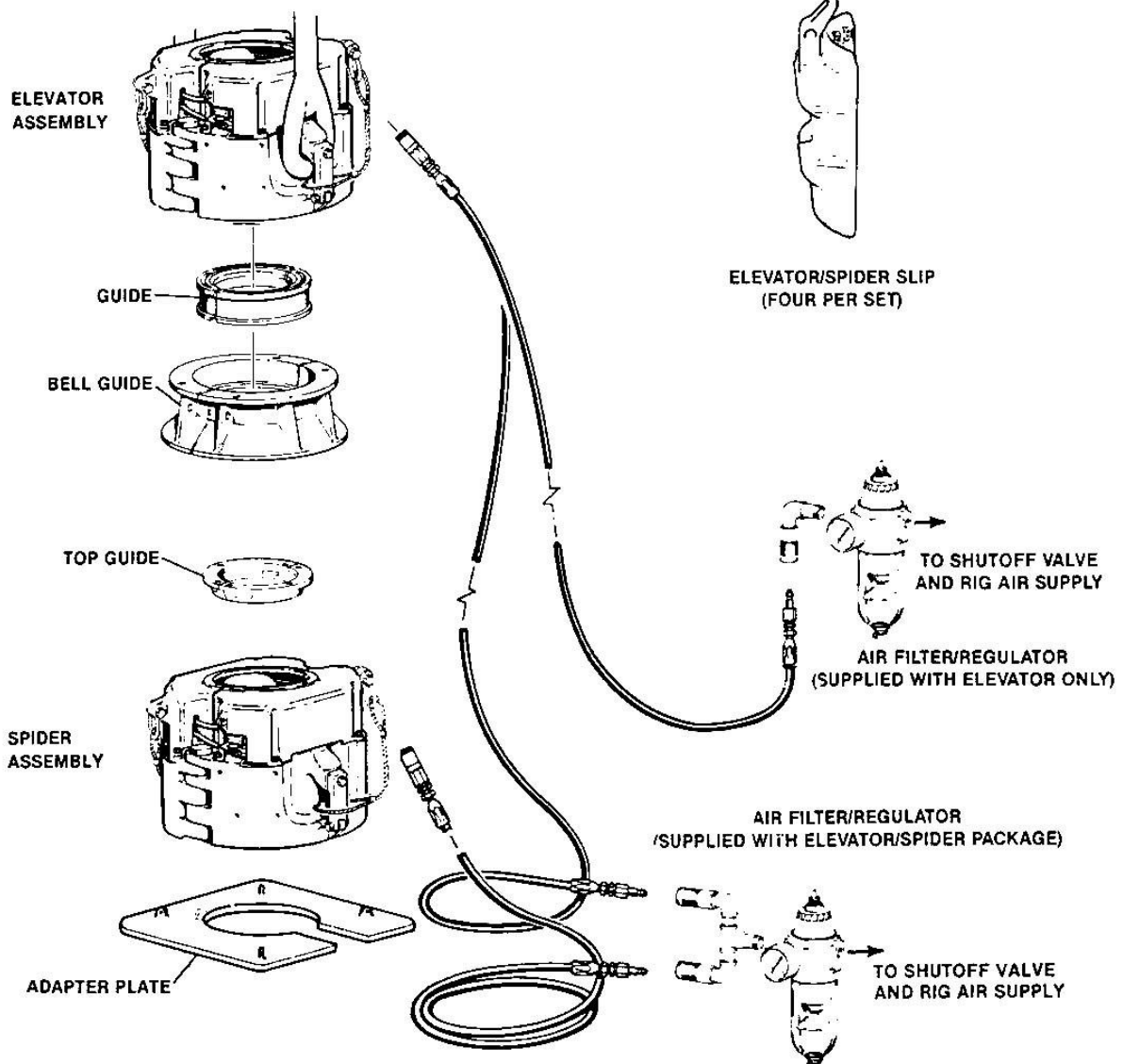

Figure 2-2. Elevator/Spider Installation

NOTE

If tools will not remain permanently with the rig, use two 50-foot air lines. Tie one 50-foot section of the hose 45-feet above floor near casing stabber. Attach second section of hose to first hose with the other end to elevator.

If tools will remain permanent with the rig, an air supply line can be run (plumbed) up the derrick. Attach a 50-foot section of hose from the elevator directly to the upper air supply line outlet.

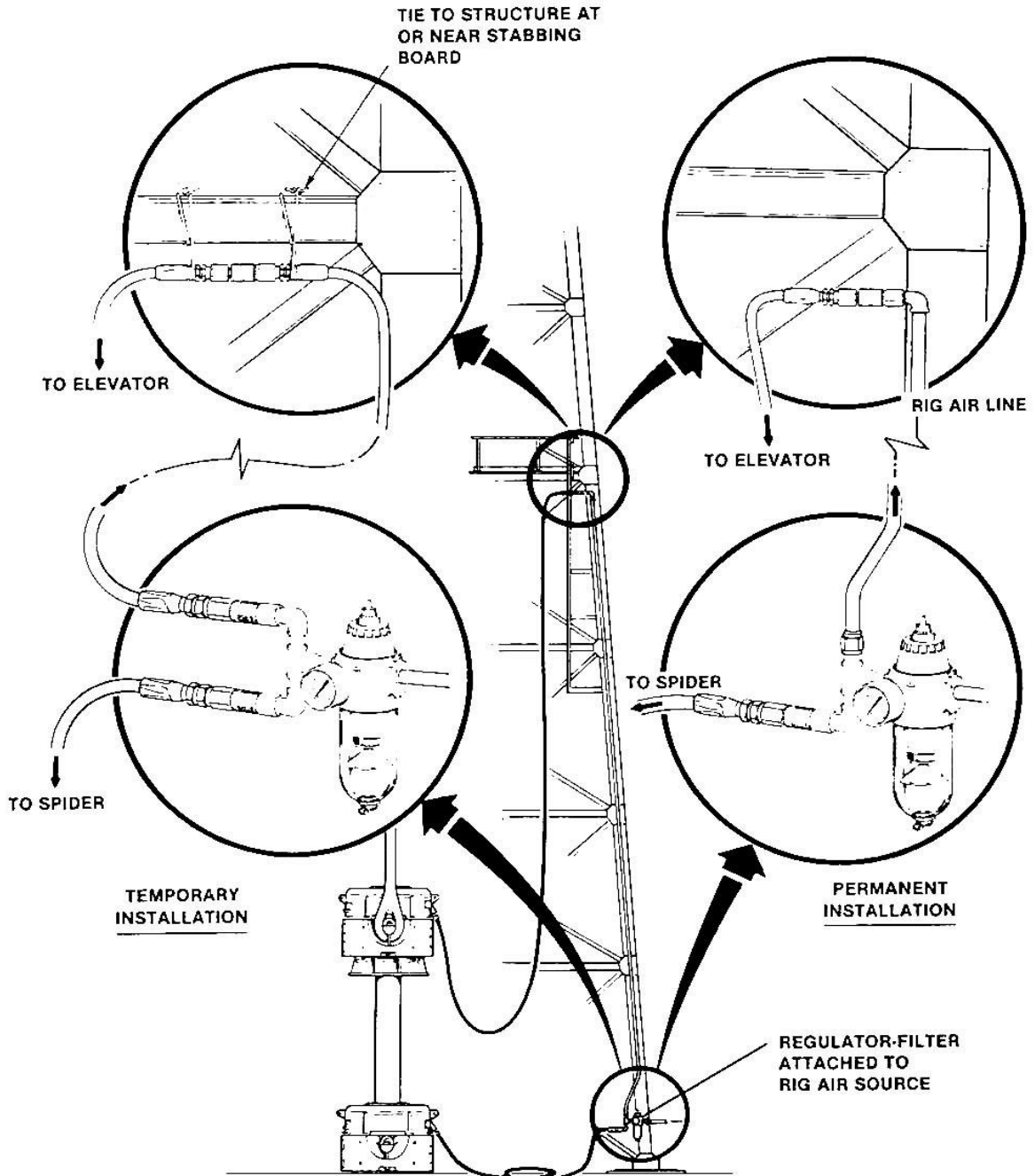

Figure 2-3. Regulator/Filter and Hose Installation

SECTION III

OPERATION

3-1. OPERATION

- a. Operation of both the elevator and spider is identical. Push the control lever down and the slips will set. Pull the control lever down and the slips will release.
- b. If an air pressure failure occurs, the slips can be set by hand:

1. Place a 5 foot pry-bar into the manual lift lever.
2. Push down on bar and move control lever to the "up" position (this moves latch to hold slips up).
3. Set slips by moving control lever down.

3-2. RUNNING CASING

NOTE

Slips and guide ring in both the elevator and spider must match the casing size being run (see Tables 3-1 or 3-2).

- a. With the casing string held by the spider, pick up the next joint of casing with a single joint pickup elevator.
- b. Hoist the add on stand of casing and stab it into the casing string. Make up the joint.
- c. Pick up the weight of the casing string with elevator. Release spider and lower the casing string.
- d. Set the spider slips to grip the casing and then release the elevator slips.

CAUTION

The spider slips must be set before releasing the elevator slips.

3-3. CHANGING SLIPS

- a. Removing Slips (Figure 3-1).

1. Remove top covers and apply air pressure to raise the slips.
2. With overhead hoist attached to slip

lifting eye, pick up enough to take up the weight of the slip.

3. With slip weight eased, remove lynch pin and slip hanger pin. Hoist slip from body.
4. Repeat steps 2 and 3 for remaining slips.

Installing Slips.

1. Clean bowl of all dirt and old grease
2. Be sure that replacement slips are clean and the correct size for the casing being run (Table 3-1 or 3-2).
3. Liberally coat the inner body and the backs of the slips with a good quality multipurpose water-resistant grease.

NOTE

Do not use tool joint compound (Dope). It is not a Lubricant.

4. Hoist slip into place and install the slip hanger pin, manipulating the slip with the hoist as necessary to allow the pin to slide all the way in.
5. Install the lynch pin and lip its ring over the end of the slip hanger pin.
6. Repeat steps 3, 4, and 5 for the remaining slips.

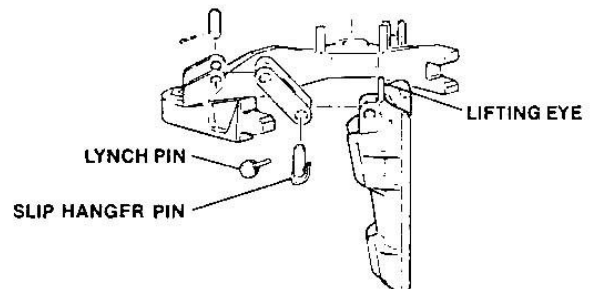

Figure 3-1. Changing Slips

3-4. CHANGING ELEVATOR BOTTOM GUIDE

- a. Using the bail, hoist the removable hinge pin from the body. Swing the body halves apart.
- b. Remove bolts and guide keepers.
Remove guide halves from both body halves.
- c. Thoroughly clean the guide groove.
- d. Be certain that replacement guide is the correct size for the casing being run (Table 3-1).
- e. Install guide halves and retain with guide keepers and bolts (Figure 3-2).
- f. Swing body halves closed and install removable hinge pin.

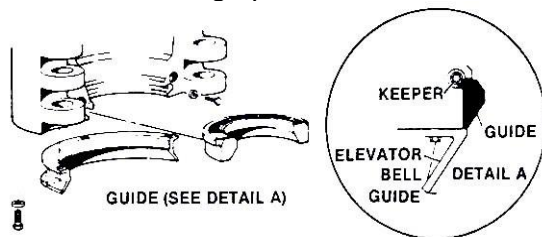

Figure 3-2. Elevator Bottom Guide Installation

3-5. CHANGING SPIDER TOP GUIDE

- a. Remove top guide retainer bolts.
Remove guide halves from both body halves.
- b. Be certain that replacement guide is the correct size for the casing being run (Table 3-1 or 3-2).
- c. Install guide halves and retain with bolts.

Table 3-1. 350 Ton Elevator/Spider and Component Part Numbers

350 TON			PART NUMBERS		
Elevator/Spider Less Slips and Guides			11776		
Bell Guide Kit			11798		
Spider Adapter Plate			19276		
350 Ton Link Set (Lengths)					
80 inch (2134 mm)			16966		
96 inch (2348 mm)			16111		
108 inch (2743 mm)			15386		
132 inch (3553 mm)			16967		
240 inch (6096 mm)			71674-1		
<hr/>					
Casing Size (inches)	Elevator Bottom Guide P/N	Spider Top Guide P/N	Slip Set P/N	Insert Set* P/N	Slip Body Size (in.)
4-1/2	11787	18419-1	11865	2168-16B-24	5-1/2
5	11788	18419-2	11864	2169-16B-24	5-1/2
5-1/2	11789	18419-3	11863	2170-40	5-1/2
6-5/8	11791	18419-4	11861	2632-24B-36	7-5/8
7	11791	18419-4	11860	2623-24B-36	7-5/8
7-5/8	11792	18419-5	11859	2633-60	7-5/8
7-3/4	11792	18519-5	71592-1	2649-60	7-5/8
8-5/8	11793	18419-6	11857	2640-32B-48	9-5/8
8-3/4	11793	18419-6	71591-3	2650-32B-48	9-5/8
9-5/8	11794	18419-7	11856	2633-80	9-5/8
9-3/4	71231	18419-15	71591-2	2649-80	9-5/8
9-7/8	71231	18419-15	71591-1	2649-80	9-5/8
10-3/4	11795	18419-8	11854	2640-40B-60	11-3/4
10-7/8	11795	18419-8	71590-1	2650-40B-60	11-3/4
11-3/4	11796	18419-9	11853	2637-100	11-3/4
11-7/8	11796	18419-9	71590-2	2651-100	11-3/4
13-3/8	11797	18419-10	70732-5	2637-100	14
13-1/2	71228	18419-12	70732-4	2652-40B-60	14
13-5/8	71228	18419-12	70732-3	2653-40B-60	14
13-3/4	71228	18419-12	70732-2	2655-40B-60	14
14	15939	18419-11	70732-1	2635-100	14

*Numbers followed by the letter "B" indicate beveled inserts (required at top and bottom of each slot).

Table 3-2. 500 Ton Elevator/Spider and Component Part Numbers

500 TON			PART NUMBERS		
Elevator/Spider Less Slips and Guides			13800		
Bell Guide Kit			11798		
Spider Adapter Plate			19276		
350 Ton Link Set (Lengths)					
132 inch (3353 mm)			16968		
144 inch (3658 mm)			15833		
160 inch (4064 mm)			18057		
240 inch (6096 mm)			71675-1		
<hr/>					
Casing Size (inches)	Elevator Bottom Guide P/N	Spider Top Guide P/N	Slip Set P/N	Insert Set* P/N	Slip Body Size (in.)
4-1/2	11787	18419-1	13842-3	2168-16B-32	5-1/2
5	11788	18419-2	13842-2	2169-16B-32	5-1/2
5-1/2	11789	18419-3	13842-1	2170-48	5-1/2
6-5/8	11791	18419-4	13841-3	2632-24B-48	7-5/8
7	11791	18419-4	13841-2	2623-24B-48	7-5/8
7-5/8	11792	18419-5	13/41-1	2633-72	7-5/8
7-3/4	11792	18519-5	13841-4	2649-72	7-5/8
8-5/8	11793	18419-6	13840-3	2640-32B-64	9-5/8
8-3/4	11793	18419-6	13840-5	2650-32B-64	9-5/8
9-5/8	11794	18419-7	13840-1	2633-96	9-5/8
9-3/4	71231	18419-15	13840-4	2649-96	9-5/8
9-7/8	71231	18419-15	13840-2	2649-96	9-5/8
10-3/4	11795	18419-8	13839-3	2640-40B-80	11-3/4
10-7/8	11795	18419-8	13839-4	2650-40B-80	11-3/4
11-3/4	11796	18419-9	13839-2	2637-120	11-3/4
11-7/8	11796	18419-9	13839-1	2651-120	11-3/4
13-3/8	11797	18419-10	70734-5	2637-120	14
13-1/2	71228	18419-12	70734-4	2652-40B-80	14
13-5/8	71228	18419-12	70734-3	2653-40B-80	14
13-3/4	71228	18419-12	70734-2	2655-40B-80	14
14	15939	18419-11	70734-1	2635-120	14

*Numbers followed by the letter "B" indicate beveled inserts (required at top and bottom of each slot).

SECTION IV

MAINTENANCE

4-1. LUBRICATION

Thorough lubrication is important for reliable operation of the elevator/spider. To ensure trouble-free performance, lubricate per Figure 4-1. The grease used for lubrication should be a high-quality multipurpose water-resistant grease, NLGI grade 2. Do not use tool joint compound (Dope). It is not a lubricant.

NOTE

Lubricate after every 50 joints of casing run and more frequently if necessary to prevent slips from sticking in elevator or spider body. Lubricate with the slips set without any casing load on tool.

4-2. REGULATOR/FILTER MAINTENANCE

- a. Open petcock at bottom of the bowl and drain accumulated water. Close petcock when water stops flowing.
- b. Remove filter element and clean with kerosene or diesel fuel every 3 months, or more often if required.

CAUTION

Plastic filter bowl can be damaged and fail if strong solvents or oils containing fire-retardant additives are used for cleaning.

- c. Use kerosene or warm water to clean the filter bowl.

4-3. LUBRICATOR MAINTENANCE

- a. Close shutoff valve.
- b. Remove self-venting fill plug.
- c. Fill reservoir to within ¼ inch of top of bowl with SAE 10 Oil; for temperatures below 20°F (-7°C) use a mixture of equal parts of SAE 10Oil and diesel fuel.
- d. Install fill plug.
- e. Open shutoff valve one turn.

Table 4-1. Troubleshooting

Symptom	Possible Cause	Remedy
Slips do not operate or operate slowly in both directions.	Air pressure supply too low.	Check air pressure at regulator. Adjust as necessary.
	Air line kinked or leaking.	Straighten or replace.
	Lubricator oil level low.	Fill (paragraph 4-3).
	Control valve faulty*.	Replace.
	Defective cylinder seal.	Replace.
Casing slides thru set slips or casing is damaged.	Incorrect slip segments or inserts mixed with correct slip segments or insert.	Install correct slip segments or inserts.
	Worn or re-sharpened inserts.	Replace with new inserts.
Slips sticking in bowls.	Inadequate Lubrication.	Clean backs of slips and inside of bowl. Lubricate (Figure 4-1).

* Air escaping from the control valve does not necessarily mean the control valve is faulty. If there is a defective cylinder O-ring seal, the air leaking through the cylinders will be released back through the control valve. If control valve leakage is suspected, remove valve from unit and test. If valve is not leaking, inspect cylinder assemblies for defective seals.

Table 4-2. Lubrication Schedule

Ref. Fig. 4-1	Item	Number of Lube Points	Application	Lube Cycle
1	Bowl/Slip Surfaces	16	Multi-Purpose Water-Resistant Grease	*
2	Cylinder Assemblies	4	Multi-Purpose Water-Resistant Grease	Before Each Job
3	Hinge Pins	2	Multi-Purpose Water-Resistant Grease	Before Each Job
4	Control Valve & Latch	3	Multi-Purpose Water-Resistant Grease	Weekly
5	Link Pins	8	SAE10 oil	Weekly

*Lubricate after every 50 joints of casing run and more frequently if necessary to prevent slips from sticking in the Elevator or Spider Body. To lubricate properly the slips should be in the set position without any casing load on unit.

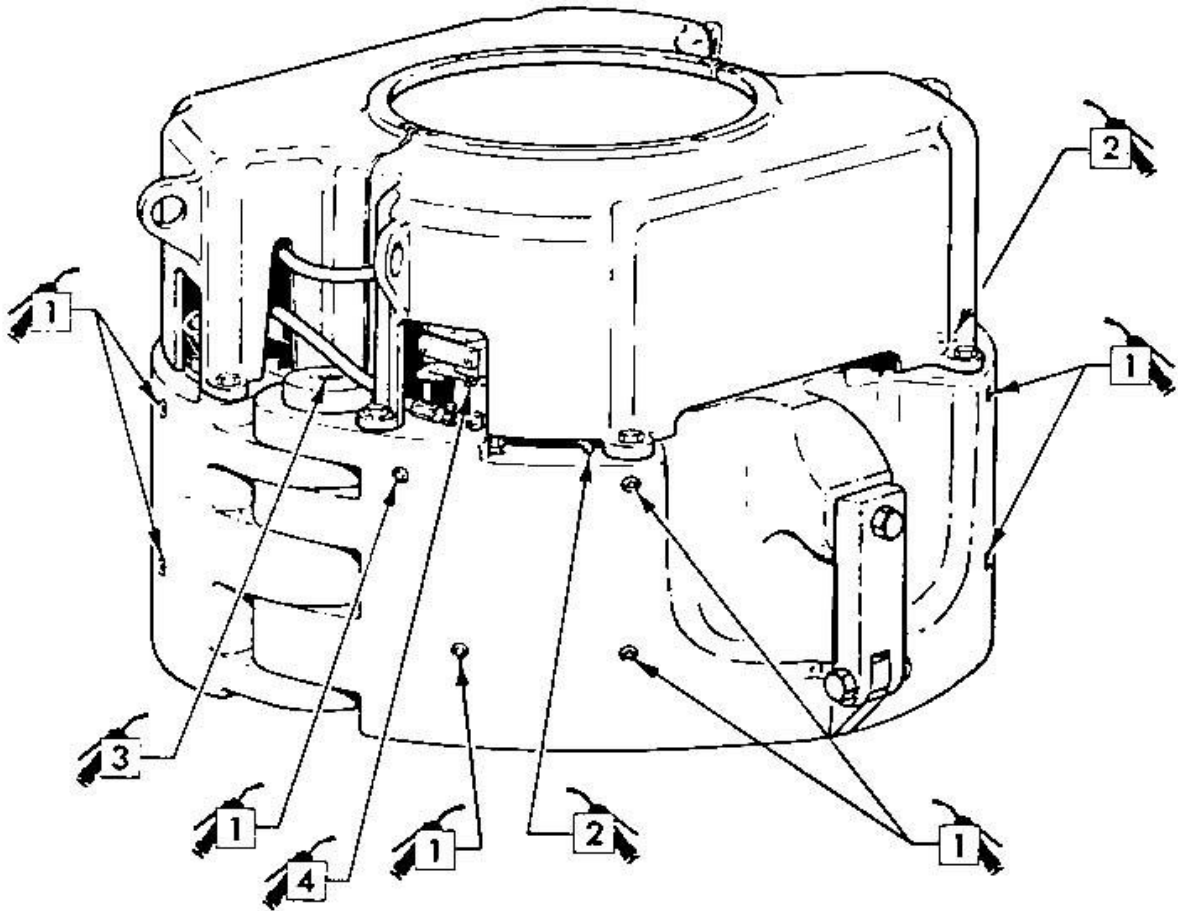

Figure 4-1. Lubrication Points

SECTION V

DISASSEMBLY, INSPECTION & ASSEMBLY

5-1. DISASSEMBLY AND INSPECTION

NOTE

All disassembly should be performed in a dry, dirt-free area.

a. Elevator/Spider Disassembly (Figure 6-1 or 6-3)

1. Raise slips to the up (release) position.
2. Use an overhead lift to remove cover halves, after removing hex head bolts and lockwashers.
3. Remove slip segments, as described in paragraph 3-3.
4. Remove upper link pins and cotter pins to remove links.

5. Remove air lines to control valve, lubricator and air cylinders.
6. Remove lubricator and pipe nipple that attaches it to mounting bracket.
7. Remove bolts and lockwashers holding lubricator mounting bracket in position.
8. Remove bolts and lockwashers holding control valve in position. Disassembly of unit is described in paragraph 5-1, part c.
9. Remove nut, lockwasher and flat washer from each air cylinder rod.
10. Remove both leveling beams.
11. Remove hex head bolts, lockwashers and cylinder retainers. Disassembly of cylinders is described in paragraph 5-1, part b.
12. Remove hinge pin and open elevator/spider body.
13. Remove guides as described in paragraph 3-4.

Table 5-1. Inspection of Elevator/Spider

ITEM	LIMITS
Leveling Beam	Check for distortion, bent or worn bracket supports.
Links, Link pins, and pivot pins	Check for galling and out-of-round in pivot pins. (Pins should be capable of being rolled on a flat surface without evidence of out-of-round).
Slip Segments	Check for worn insert, cracked or distorted slip body and worn link pin mating surface.
Bell Guide	Check that Elevator Bell Guide bolts are tight.
Grease Fittings	Check grease fittings are not plugged and threads are not stripped or damaged.
Hinge Pins	Check for bent or otherwise damaged hinge pins. Check that bail on removable pin is securely attached.

b. Air Cylinder Disassembly (Figure 6-3)

1. Remove snap ring from cylinder barrel at rod end.
2. Pull and remove gland assembly. Remove wiper ring and seals from gland.
3. Carefully remove piston rod with piston head.
4. Remove snap ring to separate piston head from rod. Remove dowel pin from rod.
5. Remove seals and back-up rings from piston head.
6. Remove snap ring from piston end of cylinder barrel.
7. Remove blank end and seal from groove in blank end.

Table 5-2. Inspection of Air Cylinder.

ITEM	LIMITS
Barrel	Check barrel for scoring, galling, distortion and excessive wear.
Piston and Gland	Check for worn or cracked shoulders and scratched or damaged sealing surfaces that would cause leakage.
Piston Rod	Check rod diameter for distortion, galling and metal wear.

c. Valve and Latch Disassembly (Figure 6-4).

1. Remove grease fittings.
2. Remove screws and lockwashers that retain spring cover.
3. Remove latch plate springs, roll pins, valve link, valve handle and latch plate.
4. Remove screws and lockwashers that retain the holding plate
5. Remove screws, nuts and lockwashers that retain the air control valve.
6. Remove screws and Hi-collar lockwashers that hold the lock spring retainer and spring.
7. Remove dowel pin and lock down.

Table 5-3. Inspection of Control Valve.

ITEM	LIMITS
Latch Plate Springs	Check that springs have equal length and will return to 3 inches after being fully compressed. Check for broken or distorted coils.
Valve Mechanism	Check for smooth lever action and slip operation without binding or malfunction.

5-2. ASSEMBLY

NOTE

All assembly should be performed in a dry, dirt-free area. It is recommended that all new seals be installed to assure reliable operation. Lubricate all seals at time of assembly.

a. Valve and Latch Assembly (Figure 6-3).

1. Insert dowel pin in lock down and install in valve bracket.
2. Insert spring into lock down and cover with lock spring retainer. Attach retainer with screws and Hi-collar lockwashers.
3. Attach air control valve with screw, nuts and lockwashers.
4. Attach holding plate with screws and lockwashers.
5. Attach valve link to valve handle with roll pin.
6. Attach latch plate and valve handle with valve link and retain with roll pin through valve handle body.
7. Install latch plate springs and retain with spring cover, screws and Hi-collar lockwashers.
8. Install grease fittings.

b. Air Cylinder Assembly (Figure 6-4).

1. Install seal in groove in blank end.
2. Install blank end in cylinder barrel and retain with snap ring.
3. Install seals and back-up rings in piston head.
4. Install dowel pin in piston rod. Attach piston head to piston rod with snap ring.
5. Insert piston rod with piston head into

cylinder barrel.

6. Install wiper ring and seals in gland. Insert gland into cylinder over piston rod.
 7. Install snap ring in cylinder barrel at rod end.
- #### c. Elevator/Spider Assembly (Figure 6-1 or 6-2)
1. With stationary hinge pin in place, open body halves.
 2. Install the four air cylinders, with air and grease fittings, into the elevator/spider body. Secure in position with bolts, lockwashers, and cylinder retainers.
 3. Install leveling beams with the valve mounting plate positioned at the stationary hinge side of body. Locate dowel pin in cylinder rod end with slots in leveling beam.
 4. Install valve and latch mechanism and attach with bolts and lockwashers. Position lever in down position.
 5. Install manual lift assembly with bolts and lockwashers.
 6. Install lubricator, pipe nipple and bracket with bolts and lockwashers.
 7. Attach leveling beams to air cylinder rods with nuts, lockwashers, and flat washers. Be certain that cylinder rod dowels are engaged in slots in leveling beams.
 8. Install pneumatic lines as indicated in Figures 6-1 or 6-2.
 9. Install slip support links with upper link pins and cotter pins. Install slips as described in paragraph 3-3.
 10. Attach cover halves with bolts and lockwashers and then install the safety sling.

SECTION VI

ILLUSTRATED PARTS LISTS

6-1. INTRODUCTION

The illustrated parts lists contain views of each assembly, exploded to show components. A complete listing of all parts is contained in the related parts list. When ordering, refer to parts by PART NUMBER ONLY – never by drawing index number.

6-2. DESCRIPTION OF THE LIST SYSTEM

a. The parts list pages are divided into four columns:

1. Drawing item number—parts are given an item number for cross-reference to the related illustration.
2. Part number—numbers listed in this column are BVM part numbers for the

described part.

3. Description—the identifying word is the first part of the description, followed by additional details.
4. Quantity per unit—numbers listed in this column indicate the quantity of any particular item used in the area shown. Referenced items are designated REF

b. Each illustration refers to a particular assembly:

Figure No.	Description	
6.1	350 Ton Elevator/Spider Assembly	
6.2	Elevator/Spider Assembly	500 Ton
6.3	Assembly	Air Cylinder
6.4	Assembly	Valve & Latch
6.5	Assembly	Air Inlet
6-6	Assembly	Valve

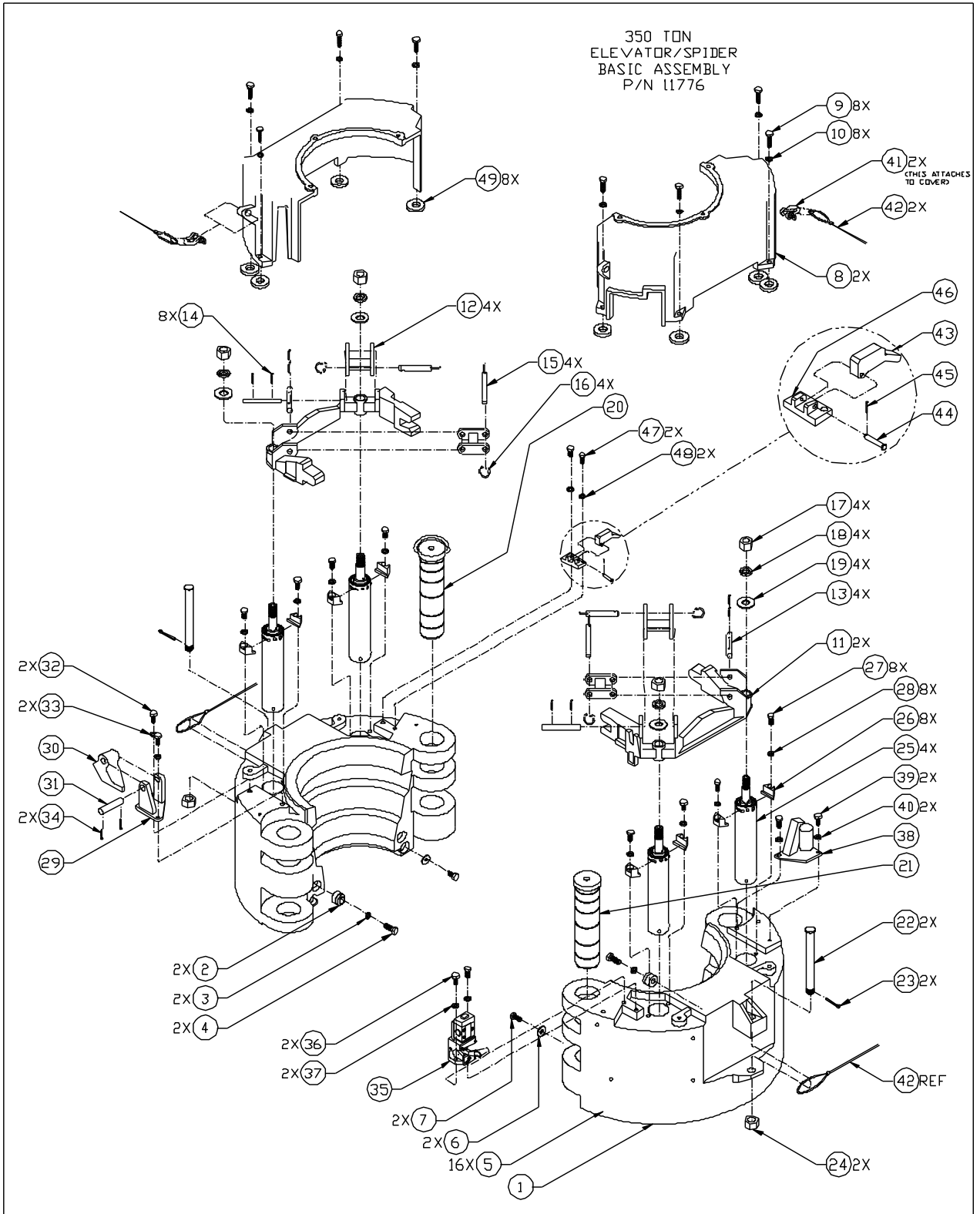

Figure 6-1. 350 Ton Elevator/Spider Assembly (Part 1 of 2)

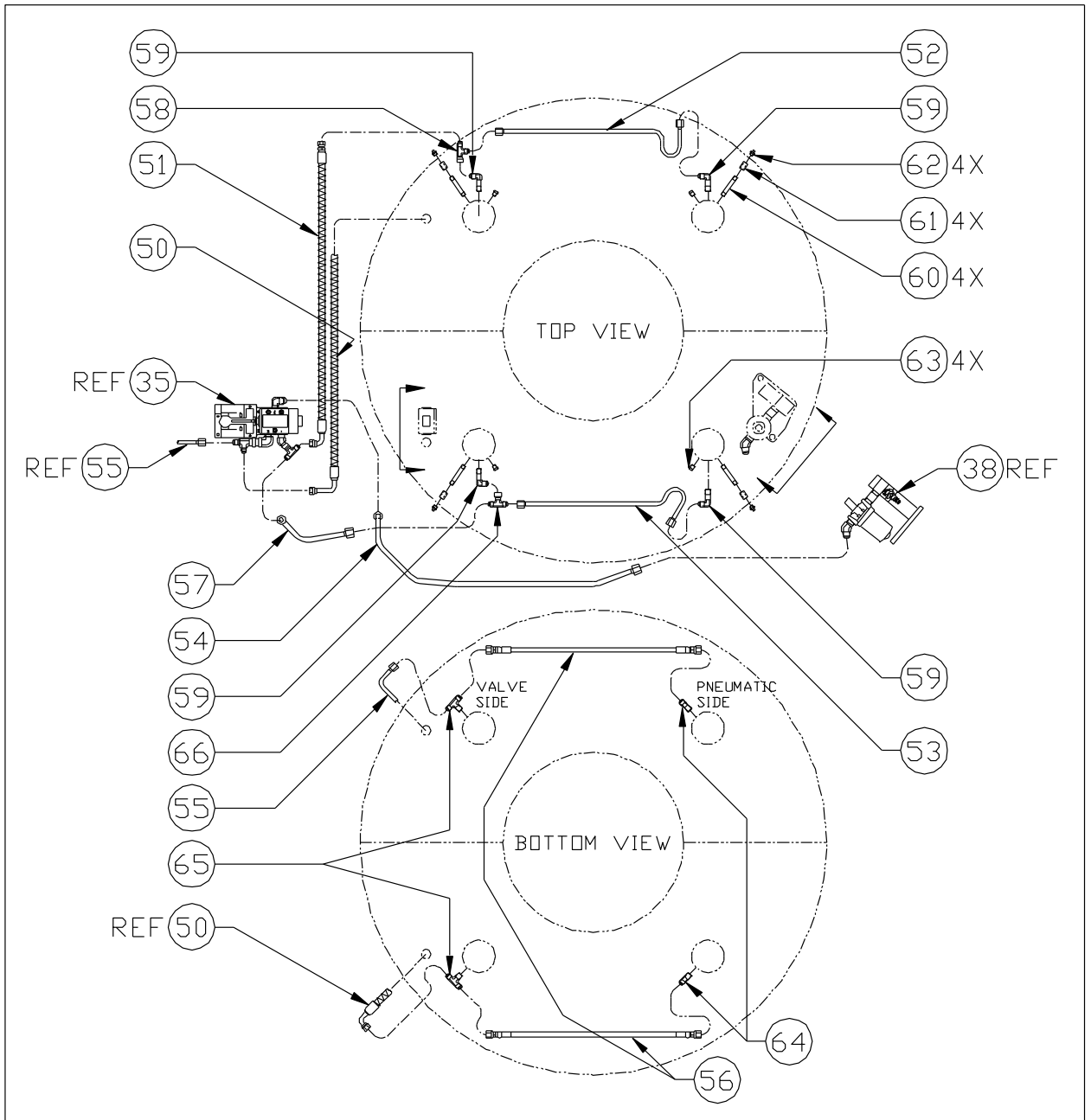

Figure 6-1. 350 Ton Elevator/Spider Assembly (Part 2 of 2)

Table 6-1. 350 Ton Elevator/Spider Parts List Index			QTY/ UNIT
ITEM #	PART #	DESCRIPTION	
	B11776	ELEVATOR/SPIDER ASSY, 350 Ton	
1	B11780	BODY.....	2
2	79882	BUTTON, Register.....	2
3	1212C-16-8	SCREW, Socket Head.....	2
4	940308-1	FITTING, Grease.....	16
5	24080-00-0	KEEPER, Guide.....	4
6	1608C-06-5	SCREW, Hex Head.....	4
7	B17913	COVER, Top.....	2
8	1410C-18-5	SCREW.....	8
9	20100-00-0	LOCKWASHER.....	8
10	B11783	BEAM, Leveling.....	2
11	B11877	LINK.....	4
12	B11878	PIN, Upper Link.....	4
13	30030-12-0	PIN, Cotter.....	8
14	B11989	PIN, Lower Link.....	4
15	B7887	PIN, Lynch.....	4
16	6020F-00-0	NUT, Hex.....	4
17	20200-00-0	LOCKWASHER.....	4
18	22200-00-0	WASHER, Flat.....	4
19	B11845	PIN, Removable Hinge.....	1
20	B11844	PIN, Stationary Hinge.....	1
21	B13536	SCREW, Link Retainer.....	2
22	30040-24-0	PIN, Cotter.....	2
23	6420C-00-0	NUT, Hex.....	2
24	B11800	AIR CYLINDER ASY (see Fig 6-3 for breakdown).....	4
25	B11849	RETAINER, Cylinder.....	8
26	1408C-12-5	SCREW, Hex Head.....	8
27	20080-00-0	LOCKWASHER.....	8
28	B11840	BRACKET, Manual Lift.....	1
29	B11842	SOCKET, Manual Lift.....	1
30	B11870	PIN, Pivot.....	1
31	1408C-12-5	SCREW, Hex Head.....	2
32	20080-00-0	LOCKWASHER.....	2
33	30030-12-0	PIN, Cotter.....	2
34	B16822	VALVE AND LATCH ASY (see Fig 6-4 for breakdown).....	1
35	1408C-12-5	SCREW, Socket Head.....	2
36	20080-00-0	LOCKWASHER.....	2
37	10401	AIR INLET ASSEMBLY (see Fig 6-5 for breakdown).....	1
38	1408C-12-5	SCREW, Hex Head.....	2
39	20080-00-0	LOCKWASHER.....	2
40	B5417	SHACKLE, Anchor.....	2
41	B18122	SLING, Safety.....	2
42	B18720	LATCH, Retainer.....	1
43	B56406-18-C	PIN, Clevis.....	1
44	50AB0-07-0	PIN, Cotter.....	2
45	B18719	BRACKET, Latch.....	1
46	1408C-12-5	SCREW, Hex Head.....	2
47	20080-00-0	LOCKWASHER.....	2
48	10434	SPACER UNDER COVER.....	8
49	B18269	HOSE ASSEMBLY, Lower.....	1
50	B18268	HOSE ASSEMBLY, Upper.....	1
51	B12632	TUBE, Upper Right.....	1
52	B12632L	TUBE, Upper Left.....	1
53	B18270	TUBE, Inlet.....	1

54	B18267	TUBE, Lower Connector.....	1
55	B12633	TUBE, Lower Rubber.....	2
56	B12634	TUBE, Upper Connector.....	1
57	B6-R6X-SS	SWIVEL NUT RUN TEE.....	1
58	B6-CCTX-SS	LONG MALE ELBOW.....	4
59	B215PNL-2-25	LONG NIPPLE.....	4
60	B207P-2	COUPLING.....	4
61	940308-1	FITTING, Grease.....	4
62	B218P-2	HEX HEAD PLUG.....	4
63	B6-FTX-SS	MALE CONNECTOR.....	2
64	B6-STX-SS	MALE BRANCH TEE.....	2
65	B6-S6X-SS	SWIVEL NUT BRANCH TEE.....	1

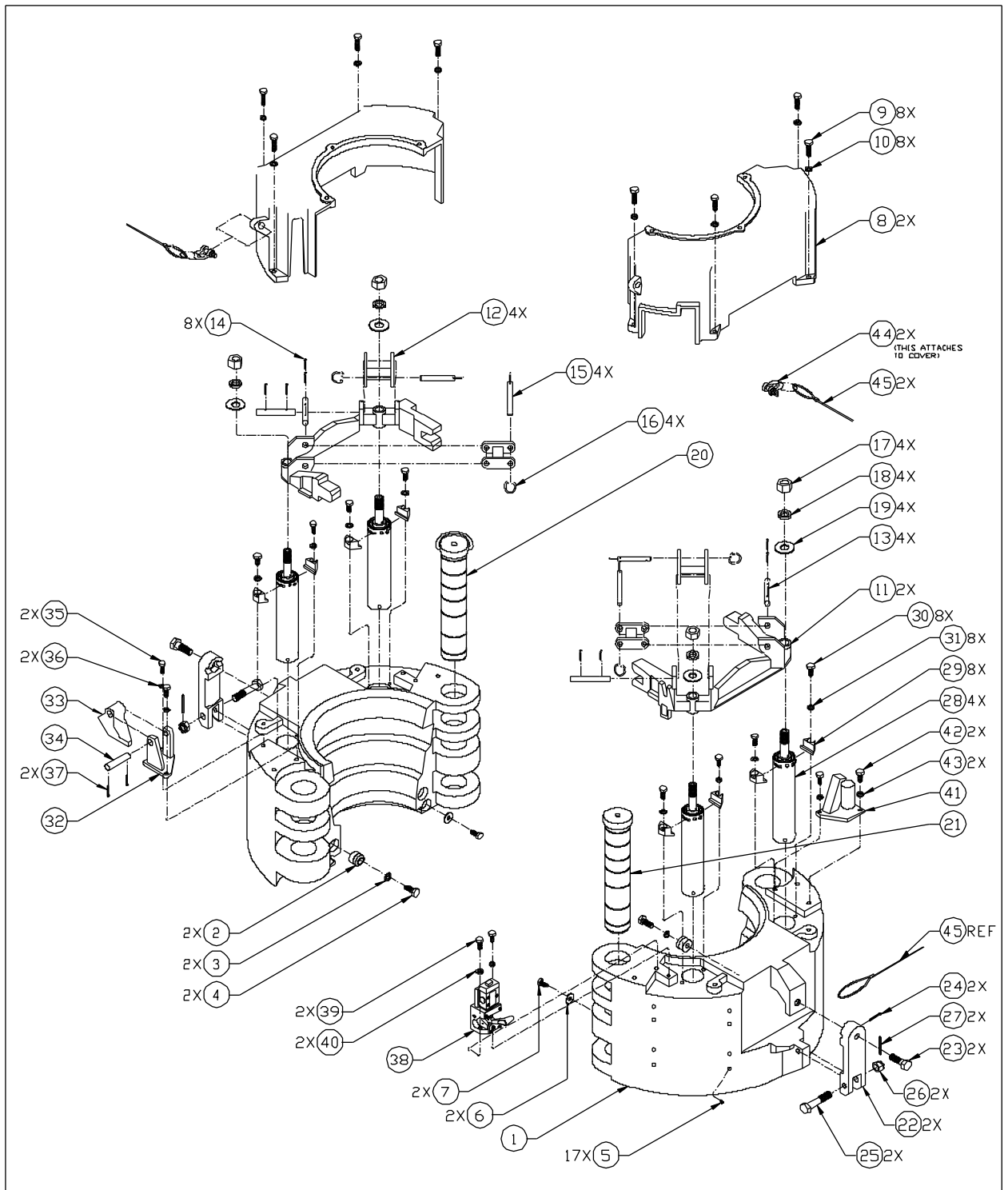

Figure 6-2. 500 Ton Elevator/Spider Assembly (Part 1 of 2)

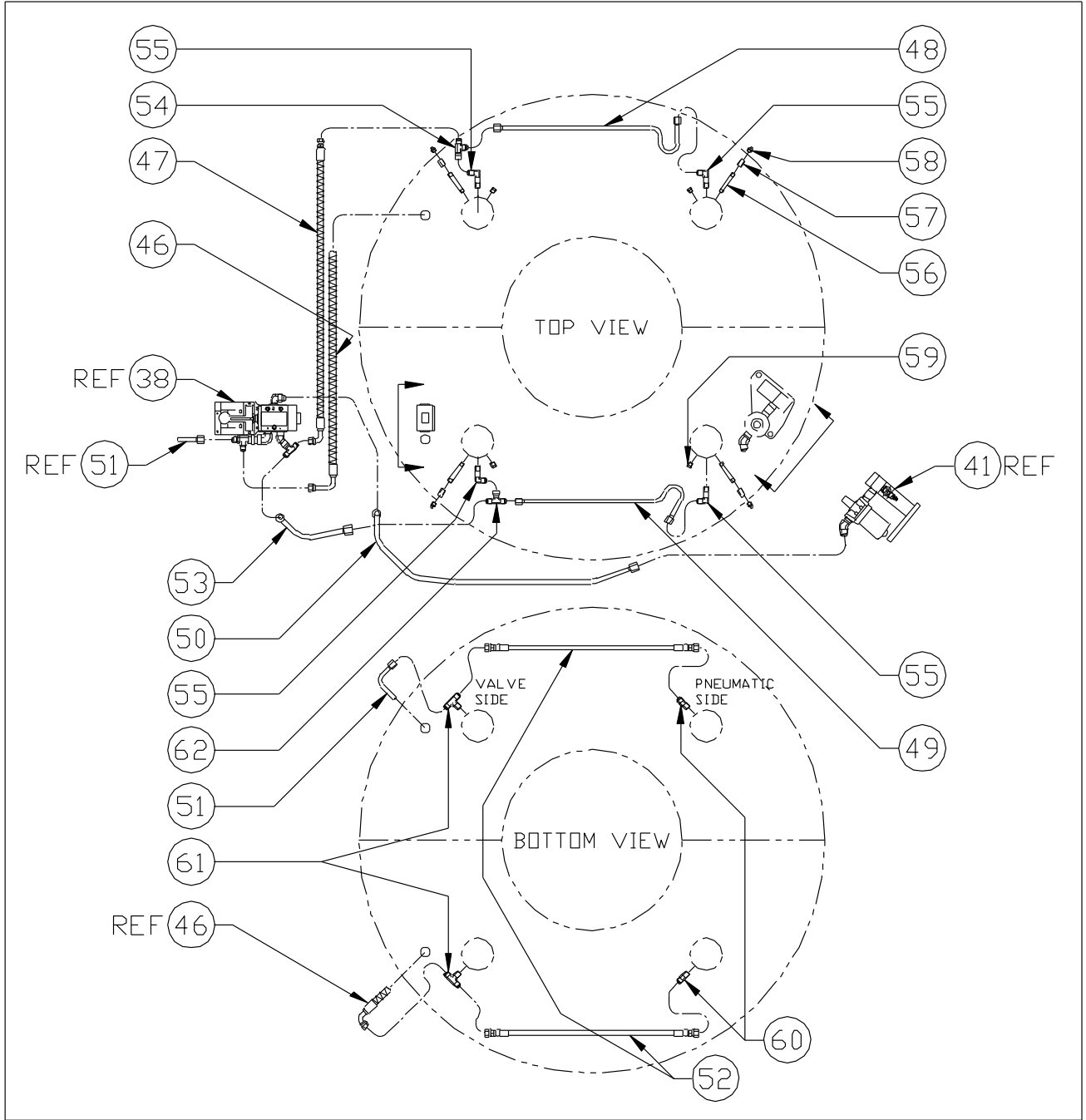

Figure 6-2. 500 Ton Elevator/Spider Assembly (Part 2 of 2)

Table 6-2. 500 Ton Elevator/Spider Parts List Index

ITEM #	PART #	DESCRIPTION	QTY/ UNIT
-	B13800	ELEVATOR/SPIDER ASSY, 500 Ton	Ref.
1	B13802	BODY	2
2	79882	BUTTON, Register	2
3	26120-00-0	LOCKWASHER, Hi-Collar	2
4	1212C-16-8	SCREW, Socket Head	2
5	79201	FITTING, Grease	16
6	B12896	KEEPER, Guide	4
7	1408C-08-5	SCREW	4
8	B17913	COVER, Top	2
9	1410C-18-5	SCREW, Hex Head	8
10	20100-00-0	LOCKWASHER	8
11	B11784	BEAM, Leveling	2
12	B11877	LINK	4
13	B11878	PIN, Upper Link	4
14	30030-12-0	PIN, Cotter	8
15	B11989	PIN, Lower Link	4
16	B7887	PIN, Lynch	4
17	6020F-00-0	NUT, Hex	4
18	20200-00-0	LOCKWASHER	4
19	22200-00-0	WASHER, Flat	4
20	B13506	PIN, Removable Hinge	1
21	B13507	PIN, Stationary Hinge	1
22	79803	BLOCK, Link	2
23	79805	SCREW, Cap Modified	2
24	30030-24-0	PIN, Cotter	2
25	79261	SCREW, Cap Modified	2
26	6416C-00-0	NUT, Castle	2
27	30030-16-0	PIN, Cotter	2
28	B11800	AIR CYLINDER ASSEMBLY (see Fig. 6-3 for breakdown)	4
29	B11849	RETAINER, Cylinder	8
30	1408C-12-5	SCREW, Hex Head	8
31	20080-00-0	LOCKWASHER	8
32	B11840	BRACKET, Manual Lift	1
33	B11842	SOCKET, Manual Lift	1
34	B11870	PIN, Pivot	1
35	1408C-12-5	SCREW, Hex Head	2
36	20080-12-0	LOCKWASHER	2
37	30030-12-0	PIN, Cotter	2
38	B16822	VALVE AND LATCH ASSEMBLY (see Fig.6-4 for breakdown)	1
39	1408C-14-5	SCREW, Socket Head	2
40	20080-00-0	LOCKWASHER	2
41	10401	AIR INLET ASSEMBLY (see Fig. 6-5 for breakdown)	1
42	1408C-12-5	SCREW, Hex Head	2
43	220080-00-0	LOCKWASHER	2
44	B5417	SHACKLE, Anchor	2
45	B18122	SLING, Safety	2
46	B18269	HOSE ASSEMBLY, Lower	1
47	B18268	HOSE ASSEMBLY, Upper	1
48	B12632	TUBE, Upper Right	1
49	B12632L	TUBE, Upper Left	1
50	B18270	TUBE, Inlet	1

51	B18267	TUBE, Lower Connector.....	1
52	B12633	TUBE, Lower Rubber.....	2
53	B12634	TUBE, Upper Rubber.....	1
54	B6-R6X-SS	SWIVEL NUT RUN TEE.....	1
55	B6-CCTX-SS	LONG MALE ELBOW.....	4
56	B215PNL-2-25	LONG NIPPLE.....	4
57	B207P-2	COUPLING.....	4
58	79201	FITTING, Grease.....	4
59	B218P-2	HEX HEAD PLUG.....	4
60	B6-FTX-SS	MALE CONNECTOR.....	3
61	B6-STX-SS	MALE BRANCH TEE.....	2
62	B6-S6X-SS	SWIVEL NUT BRANCH TEE.....	1

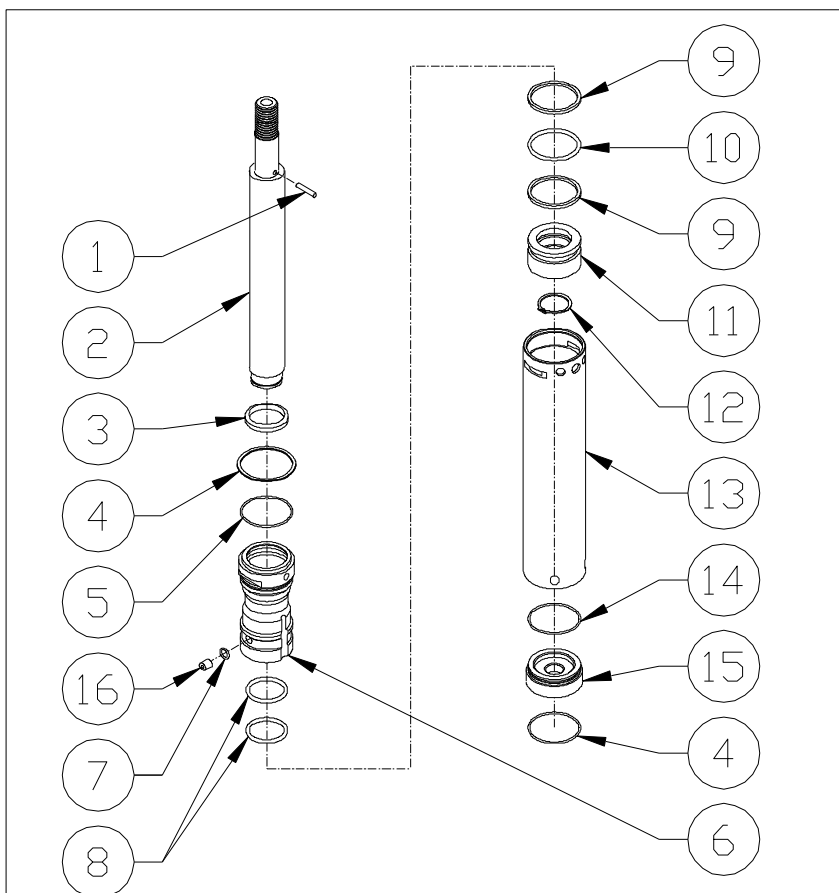

Figure 6-3. Air Cylinder Assembly

Table 6-3. Air Cylinder Parts List Index
BVM Corp

ITEM #	PART #	DESCRIPTION	QTY/ UNIT
-	B11800	AIR CYLINDER ASSEMBLY...	Ref.
1	50040-08-0	PIN, Dowel.....	1
2	B11806	ROD, Piston.....	1
3	B11751	RING, Wiper.....	1
4	B11809	RING, Spiral Retaining.....	2
5	B51300-149-B	SEAL, O-Ring.....	1
6	B14703	GLAND, Cylinder.....	1
7	B51300-112-B	SEAL, O-Ring.....	1
8	B51300-329-B	SEAL, O-Ring.....	2
9	B51301-334	RING, Back-Up.....	2
10	B51300-334-B	SEAL, O-Ring.....	1
11	B11804	HEAD, Piston.....	1
12	B53600-175	RING, External Retainer.....	1
13	B11807	BARREL.....	1
14	B51300-149-B	SEAL, O-Ring.....	1
15	B11805	BLANK END, Cylinder.....	1
16	10483	RETAINER, O-Ring.....	1

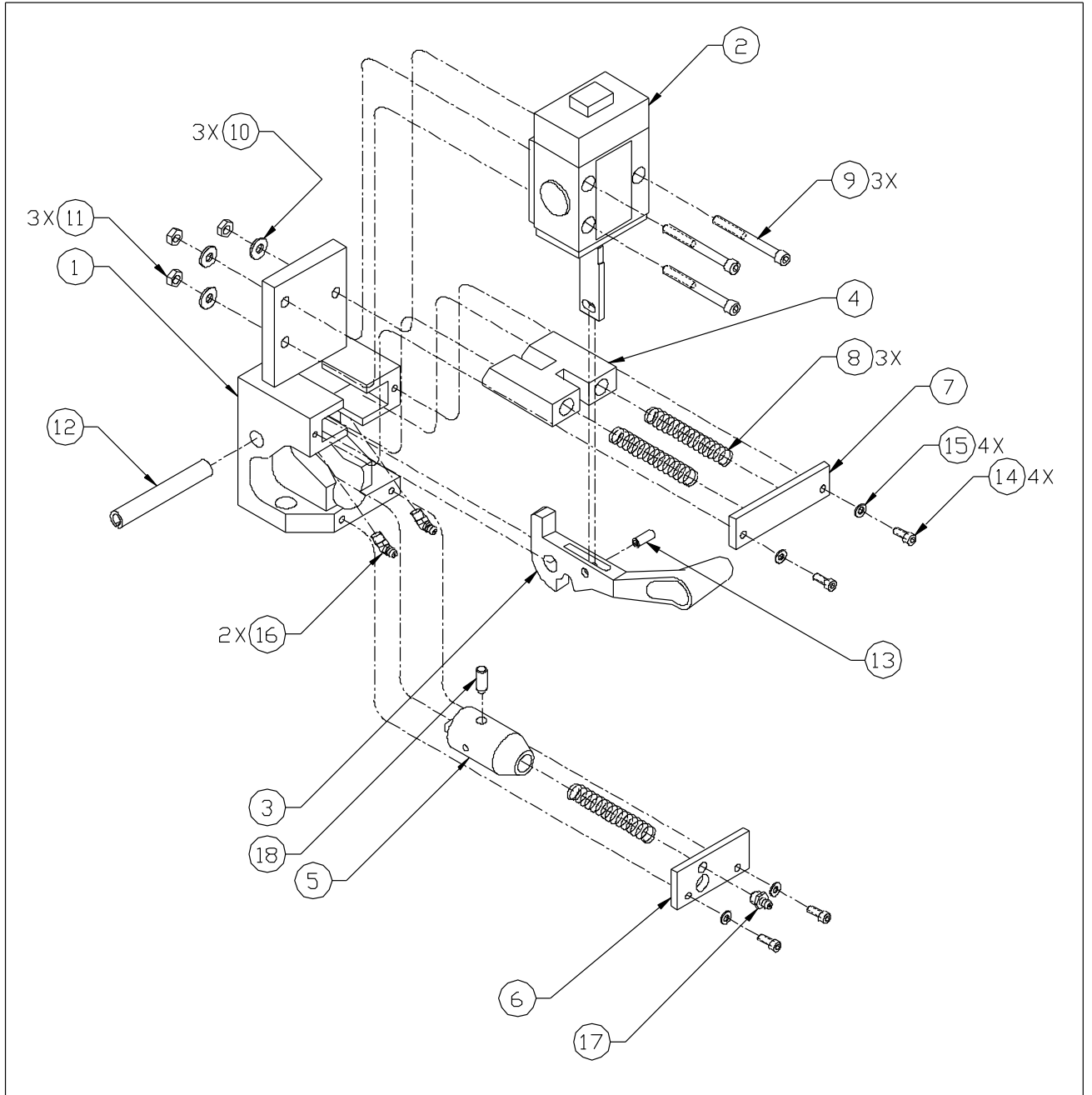

Figure 6-4. Valve & Latch Assembly

Table 6-4. Valve & Latch Parts List Index

BVM Corp			QTY/ UNIT
ITEM #	PART #	DESCRIPTION	
-	B16822	VALVE & LATCH ASSEMBLY.....	Ref.
1	B16824	BRACKET, Valve.....	1
2	10400	VALVE ASSEMBLY (see Fig. 6-6 for breakdown)	1
3	B13088	HANDLE, Valve.....	1
4	B13032	PLATE, Latch.....	1
5	B16826	DOWN, Lock.....	1
6	B16828	RETAINER, Lock Spring.....	1
7	B11888	COVER, Spring.....	1
8	B12001	SPRING.....	3
9	1204C-20-8	SCREW, Socket Head.....	3
10	2004C-00-0	LOCKWASHER.....	3
11	6004C-00-0	NUT, Hex.....	3
12	40080-00-0	PIN, Roll.....	1
13	40100-00-0	PIN, Roll.....	1
14	120JC-05-8	SCREW, Socket Head.....	4
15	260J0-00-0	LOCKWASHER, Hi-Collar.....	4
16	79202	FITTING, 45 Deg Grease.....	2
17	79201	FITTING, Grease.....	1
18	50050-04-0	PIN, Dowel.....	1

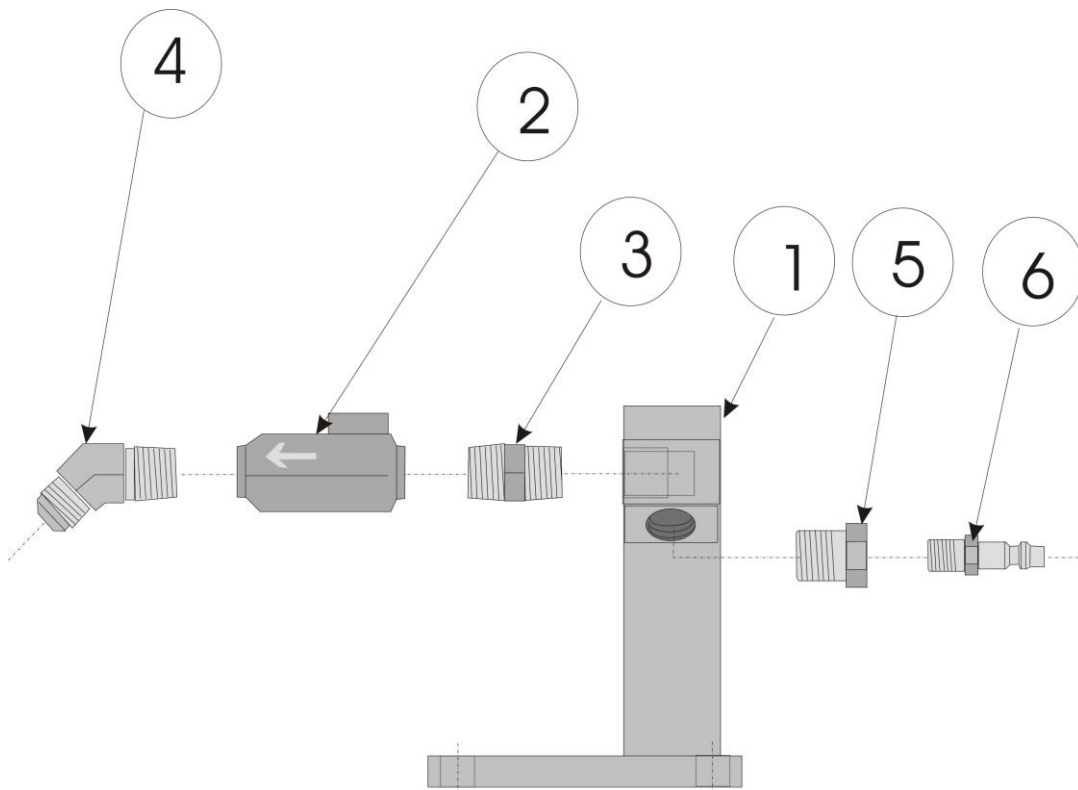

Figure 6-5. Air Inlet Assembly

Table 6-5. Air Inlet Parts List Index

BVM Corp			QTY/ UNIT
ITEM #	PART #	DESCRIPTION	
-	10401	AIR INLET ASSEMBLY	Ref.
1	B11838	BRACKET, Lube Mounting.....	1
2	10528RA	LUBRICATOR.....	1
3	B216P-8	NIPPLE.....	1
4	B8-8-VTX-SS	MALE ELBOW.....	1
5	B209P-8-4	BUSHING.....	1
6	BH2C	NIPPLE, Coupler (Quick Disconnect Fitting)..	1

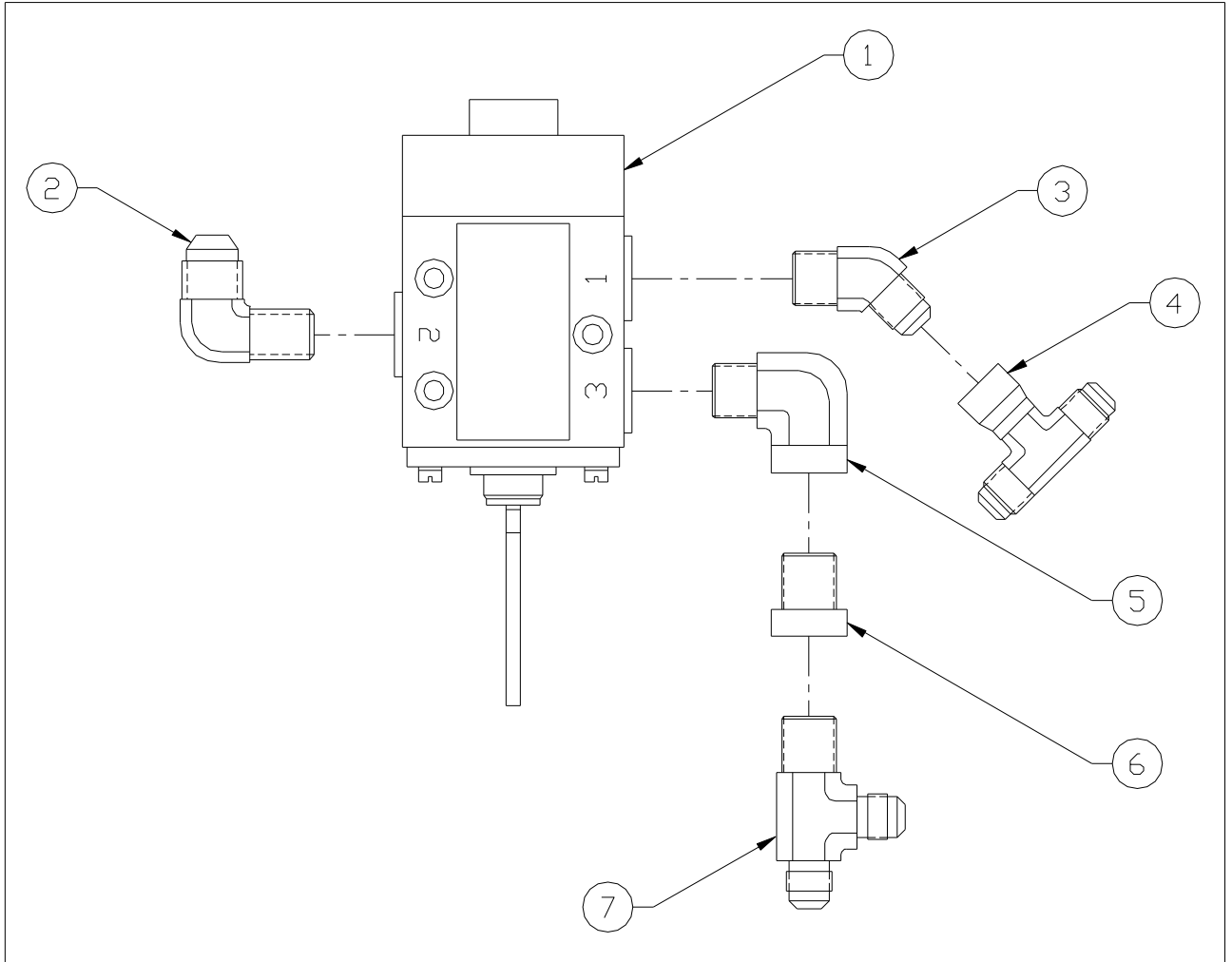

Figure 6-6. Valve Assembly

Table 6-6. Valve Parts List Index

BVM Corp			QTY/ UNIT
ITEM #	PART #	DESCRIPTION	
-	10400	VALVE ASSEMBLY.....	Ref.
1	10405	PNEUMATIC DIRECTION VALVE.....	1
2	B8-CTX-SS	MALE ELBOW.....	1
3	B6-6-VTX-SS	45 DEG MALE ELBOW.....	1
4	B6-S6X-SS	SWIVEL NUT BRANCH TEE.....	1
5	B3/8 CD-SS	STREET ELBOW.....	1
6	BPTR-S	REDUCER.....	1
7	B6-RTX-SS	MALE RUN TEE.....	1