



# Agilent E1401B High Power Mainframe

## User's Guide and Service Manual

### Where to Find it - Online and Printed Information:

System installation (hardware/software) ..... VXIbus Configuration Guide\*  
Agilent VIC (VXI installation software)\*

Module configuration and wiring ..... This Manual

VXI*plug&play* programming ..... VXI*plug&play* Online Help

VXI*plug&play* example programs ..... VXI*plug&play* Online Help

VXI*plug&play* function reference ..... VXI*plug&play* Online Help

Soft Front Panel information ..... VXI*plug&play* Online Help



VISA language information..... Agilent VISA User's Guide

Agilent VEE programming information..... Agilent VEE User's Manual

*\*Supplied with Agilent Command Modules, Embedded Controllers, and VXLink.*



**Agilent Technologies**



# Errata

## Agilent References in this manual

**NOTICE:** This document contains references to Agilent Technologies. Agilent's former Test and Measurement business has become Keysight Technologies. For more information, go to:

[www.keysight.com](http://www.keysight.com)

## About this manual

We've added this manual to the Keysight website in an effort to help you support your product. This manual provides the best information we could find. It may be incomplete or contain dated information.

## Support for your product

You can find information about technical and professional services, product support, and equipment repair and service on the web:

[www.keysight.com](http://www.keysight.com)

Select your country from the drop-down menu at the top. Under *Electronic Test and Measurement*, click on *Services*. The web page that appears next has contact information specific to your country.

For more detailed product information, go to: [www.keysight.com/find/](http://www.keysight.com/find/) *<product model>*  
i.e., for the M9514A, use: [www.keysight.com/find/M9514A](http://www.keysight.com/find/M9514A)

Hypertext links to documents on [agilent.com](http://agilent.com) are no longer active. Use this substitution to access PDF files:

Broken links have the form: <http://cp.literature.agilent.com/litweb/pdf/> *< literature\_part\_number >*

Substitute links with this form: <http://literature.cdn.keysight.com/litweb/pdf/> *< literature\_part\_number >*

Where *< literature\_part\_number >* has the form: M9300-90001.pdf

For service notes, use: [www.keysight.com/find/servicenotes](http://www.keysight.com/find/servicenotes)



Warranty .....	3
Safety Symbols .....	4
WARNINGS .....	4
Declaration of Conformity .....	5
User Notes .....	6
<b>Chapter 1</b>	
<b>Using the Mainframe .....</b>	<b>9</b>
Mainframe Description .....	9
Line Voltage and Input Power .....	9
Air Flow .....	10
Variable Speed Fan .....	11
Rear Panel Auxiliary Connector .....	12
Remote Standby Switch .....	14
Installing the Power Line Fuse .....	15
Power Cords .....	16
Agilent E1401B Safety Grounding Information .....	17
Grounding Procedure .....	17
<b>Chapter 2</b>	
<b>Replaceable Parts and Assemblies .....</b>	<b>19</b>
Module Replacement .....	19
Component Locator .....	19
Cleaning Fan Filters .....	19
Agilent E1401B Replaceable Parts List .....	20
<b>Appendix A</b>	
<b>Agilent E1401B Specifications .....</b>	<b>25</b>
<b>Index .....</b>	<b>29</b>

*Notes:*

---

---

## Certification

*Agilent Technologies, Inc. certifies that this product met its published specifications at the time of shipment from the factory. Agilent Technologies further certifies that its calibration measurements are traceable to the United States National Institute of Standards and Technology (formerly National Bureau of Standards), to the extent allowed by that organization's calibration facility, and to the calibration facilities of other International Standards Organization members.*

---

## AGILENT TECHNOLOGIES WARRANTY STATEMENT

**PRODUCT:** E1401B

**DURATION OF WARRANTY:** 1 year

1. Agilent warrants Agilent hardware, accessories and supplies against defects in materials and workmanship for the period specified above. If Agilent receives notice of such defects during the warranty period, Agilent will, at its option, either repair or replace products which prove to be defective. Replacement products may be either new or like-new.
2. Agilent warrants that Agilent software will not fail to execute its programming instructions, for the period specified above, due to defects in material and workmanship when properly installed and used. If Agilent receives notice of such defects during the warranty period, Agilent will replace software media which does not execute its programming instructions due to such defects.
3. Agilent does not warrant that the operation of Agilent products will be interrupted or error free. If Agilent is unable, within a reasonable time, to repair or replace any product to a condition as warranted, customer will be entitled to a refund of the purchase price upon prompt return of the product.
4. Agilent products may contain remanufactured parts equivalent to new in performance or may have been subject to incidental use.
5. The warranty period begins on the date of delivery or on the date of installation if installed by Agilent. If customer schedules or delays Agilent installation more than 30 days after delivery, warranty begins on the 31st day from delivery.
6. Warranty does not apply to defects resulting from (a) improper or inadequate maintenance or calibration, (b) software, interfacing, parts or supplies not supplied by Agilent Technologies, (c) unauthorized modification or misuse, (d) operation outside of the published environmental specifications for the product, or (e) improper site preparation or maintenance.
7. TO THE EXTENT ALLOWED BY LOCAL LAW, THE ABOVE WARRANTIES ARE EXCLUSIVE AND NO OTHER WARRANTY OR CONDITION, WHETHER WRITTEN OR ORAL, IS EXPRESSED OR IMPLIED AND AGILENT SPECIFICALLY DISCLAIMS ANY IMPLIED WARRANTY OR CONDITIONS OF MERCHANTABILITY, SATISFACTORY QUALITY, AND FITNESS FOR A PARTICULAR PURPOSE.
8. Agilent will be liable for damage to tangible property per incident up to the greater of \$300,000 or the actual amount paid for the product that is the subject of the claim, and for damages for bodily injury or death, to the extent that all such damages are determined by a court of competent jurisdiction to have been directly caused by a defective Agilent product.
9. TO THE EXTENT ALLOWED BY LOCAL LAW, THE REMEDIES IN THIS WARRANTY STATEMENT ARE CUSTOMER'S SOLE AND EXCLUSIVE REMEDIES. EXCEPT AS INDICATED ABOVE, IN NO EVENT WILL AGILENT OR ITS SUPPLIERS BE LIABLE FOR LOSS OF DATA OR FOR DIRECT, SPECIAL, INCIDENTAL, CONSEQUENTIAL (INCLUDING LOST PROFIT OR DATA), OR OTHER DAMAGE, WHETHER BASED IN CONTRACT, TORT, OR OTHERWISE.

FOR CONSUMER TRANSACTIONS IN AUSTRALIA AND NEW ZEALAND: THE WARRANTY TERMS CONTAINED IN THIS STATEMENT, EXCEPT TO THE EXTENT LAWFULLY PERMITTED, DO NOT EXCLUDE, RESTRICT OR MODIFY AND ARE IN ADDITION TO THE MANDATORY STATUTORY RIGHTS APPLICABLE TO THE SALE OF THIS PRODUCT TO YOU.

---

## U.S. Government Restricted Rights

The Software and Documentation have been developed entirely at private expense. They are delivered and licensed as "commercial computer software" as defined in DFARS 252.227- 7013 (Oct 1988), DFARS 252.211-7015 (May 1991) or DFARS 252.227-7014 (Jun 1995), as a "commercial item" as defined in FAR 2.101(a), or as "Restricted computer software" as defined in FAR 52.227-19 (Jun 1987)(or any equivalent agency regulation or contract clause), whichever is applicable. You have only those rights provided for such Software and Documentation by the applicable FAR or DFARS clause or the Agilent standard software agreement for the product involved.

---

## IEC Measurement Category II Overvoltage Protection

This is a measurement Category II product designed for measurements at voltages up to 300V from earth, including measurements of voltages at typical mains socket outlets. The product should not be used to make voltage measurements on a fixed electrical installation including building wiring, circuit breakers, or service panels.

E1401B High Power Mainframe User's Guide and Service Manual



**Agilent Technologies**

Edition 3 Rev 2

Copyright © 1997-2006 Agilent Technologies, Inc. All Rights Reserved.

---

---

## Documentation History

All Editions and Updates of this manual and their creation date are listed below. The first Edition of the manual is Edition 1. The Edition number increments by 1 whenever the manual is revised. Updates, which are issued between Editions, contain replacement pages to correct or add additional information to the current Edition of the manual. Whenever a new Edition is created, it will contain all of the Update information for the previous Edition. Each new Edition or Update also includes a revised copy of this documentation history page.

Edition 1 ..... January 1995  
Edition 2 ..... August 1995  
Edition 3 (E1401-90009) ..... March 1997  
Edition 3 Rev 2 (E1401-90009) ..... May 2006

---

## Trademarks

Microsoft® is a U.S. registered trademark of Microsoft Corporation  
Windows NT® is a U.S. registered trademark of Microsoft Corporation  
Windows® and MS Windows® are U.S. registered trademarks of Microsoft Corporation.

---

## Safety Symbols



Instruction manual symbol affixed to product. Indicates that the user must refer to the manual for specific WARNING or CAUTION information to avoid personal injury or damage to the product.



Alternating current (AC)



Direct current (DC).



Indicates hazardous voltages.



Indicates the field wiring terminal that must be connected to earth ground before operating the equipment—protects against electrical shock in case of fault.

**WARNING**

Calls attention to a procedure, practice, or condition that could cause bodily injury or death.

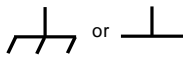

Frame or chassis ground terminal—typically connects to the equipment's metal frame.

**CAUTION**

Calls attention to a procedure, practice, or condition that could possibly cause damage to equipment or permanent loss of data.

---

## WARNINGS

The following general safety precautions must be observed during all phases of operation, service, and repair of this product. Failure to comply with these precautions or with specific warnings elsewhere in this manual violates safety standards of design, manufacture, and intended use of the product. Agilent Technologies, Inc. assumes no liability for the customer's failure to comply with these requirements.

**Ground the equipment:** For Safety Class 1 equipment (equipment having a protective earth terminal), an uninterruptible safety earth ground must be provided from the mains power source to the product input wiring terminals or supplied power cable.

DO NOT operate the product in an explosive atmosphere or in the presence of flammable gases or fumes.

For continued protection against fire, replace the line fuse(s) only with fuse(s) of the same voltage and current rating and type. DO NOT use repaired fuses or short-circuited fuse holders.

**Keep away from live circuits:** Operating personnel must not remove equipment covers or shields. Procedures involving the removal of covers or shields are for use by service-trained personnel only. Under certain conditions, dangerous voltages may exist even with the equipment switched off. To avoid dangerous electrical shock, DO NOT perform procedures involving cover or shield removal unless you are qualified to do so.

**DO NOT operate damaged equipment:** Whenever it is possible that the safety protection features built into this product have been impaired, either through physical damage, excessive moisture, or any other reason, REMOVE POWER and do not use the product until safe operation can be verified by service-trained personnel. If necessary, return the product to an Agilent Technologies Sales and Service Office for service and repair to ensure that safety features are maintained.

**DO NOT service or adjust alone:** Do not attempt internal service or adjustment unless another person, capable of rendering first aid and resuscitation, is present.

**DO NOT substitute parts or modify equipment:** Because of the danger of introducing additional hazards, do not install substitute parts or perform any unauthorized modification to the product. Return the product to an Agilent Technologies Sales and Service Office for service and repair to ensure that safety features are maintained.

---



**Manufacturer's Name:** Agilent Technologies (Malaysia) Sdn. Bhd.  
**Manufacturer's Address:** Bayan Lepas Free Industrial Zone  
**Supplier's Address:** 11900 Penang  
Malaysia

**Declares under sole responsibility that the product as originally delivered**

**Product Name:** C-Size VXI, Hi-Power Mainframe, 13-Slot  
**Model Number:** E1401B  
**Product Options:** This declaration covers all options of the above product(s)

**complies with the essential requirements of the following applicable European Directives, and carries the CE marking accordingly:**

Low Voltage Directive (73/23/EEC, amended by 93/68/EEC)  
EMC Directive (89/336/EEC, amended by 93/68/EEC)

**and conforms with the following product standards:**

EMC	Standard	Limit
	IEC 61326-1:1997+A1:1998 / EN 61326-1:1997+A1:1998	
	CISPR 11:1990 / EN 55011:1991	Group 1 Class A
	IEC 61000-4-2:1995+A1:1998 / EN 61000-4-2:1995	4 kV CD, 8 kV AD
	IEC 61000-4-3:1995 / EN 61000-4-3:1995	3 V/m, 80-1000 MHz
	IEC 61000-4-4:1995 / EN 61000-4-4:1995	0.5 kV signal lines, 1 kV power lines
	IEC 61000-4-5:1995 / EN 61000-4-5:1995	0.5 kV line-line, 1 kV line-ground
	IEC 61000-4-6:1996 / EN 61000-4-6:1996	3 V, 0.15-80 MHz
	IEC 61000-4-11:1994 / EN 61000-4-11:1994	Dips: 30% 10 ms; 60% 100 ms Interrupt: > 95% @ 5000 ms
	Canada: ICES-001:1998	
	Australia/New Zealand: AS/NZS 2064.1	

The product was tested in a typical configuration with Agilent Technologies test systems.

**Safety** IEC 61010-1:2001 / EN 61010-1:2001  
Canada: CSA C22.2 No. 1010.1:1992  
USA: UL 61010B-1:2003

**Supplementary Information:**

**This DoC applies to above-listed products placed on the EU market after:**

**December 31, 2003**

Date

**Tan, Boon Juan**

Quality Manager

For further information, please contact your local Agilent Technologies sales office, agent or distributor, or Agilent Technologies Deutschland GmbH, Herrenberger Straße 130, D 71034 Böblingen, Germany.



*Notes:*

---

*Notes:*

---

*Notes:*

---

### Mainframe Description

The Agilent E1401B mainframe is designed in full compliance with the VXIbus specification (Rev. 1.4) and VMEbus system specification (Rev. C.1). The mainframe contains 13 slots for plug-in modules and can be rack mounted in either the forward or reverse position.

- Improved Power Supply Reliability
- Solid state automatic bus grant sensing to bypass empty slots.
- Variable speed fan cooling.
- Rear mounted 25-pin D connector for auxiliary power supply monitoring.
- Easy replacement of major components - most can be replaced from the rear of the mainframe, even while the mainframe is mounted in a rack.
- Seven standard VXIbus power supply voltages - all overvoltage, overcurrent, and temperature protected.
- Maximum Usable Power (total power supply output power before thermal protection shutdown): 900 W @ 25°C, 800W @ 40°C, 650 W @ 55°C.

### Line Voltage and Input Power

The Agilent E1401B mainframe includes a power supply which automatically adjusts for standard nominal line voltages of 100/120 VAC and 220/240 VAC, and nominal power line frequencies of 50 Hz and 60 Hz. The power supply has a power factor corrected input section and thus can be powered from any nominal line input over the range of 100 VAC to 240 VAC. The power supply can also be powered from a 400 Hz AC line frequency or DC power line voltages. Refer to Appendix A for complete input power specifications.

---

**WARNING** Refer to “Agilent E1401B Safety Grounding Information” on page 17 for complete grounding information when power line frequencies exceed 66Hz.

---

# Air Flow

The air flow into the plug-in module slots in the Agilent E1401B mainframe is significantly more than previous Agilent mainframes. The mainframe supplies each of the 13 slots with enough air to cool 60 Watts while maintaining only a 10°C rise across a typically dense module. Up to 75 Watts per slot may be dissipated if a 15°C rise is acceptable across a typically dense module. The graph of Figure 1-1 shows the air flow volume (liters/second) versus change in pressure across the module (mm H<sub>2</sub>O) for the mainframe.

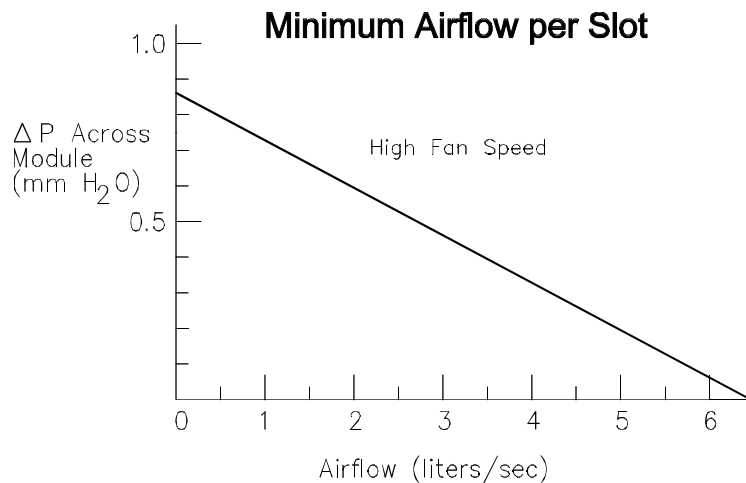

**Figure 1-1. Minimum Airflow Available Per Slot**

The mainframe has a fan chamber with three circulation fans. The speed of the fans is controlled by the ambient temperature of the air drawn into the mainframe. Air from the fan chamber is forced into the compartmentalized plenum at the bottom of the mainframe. Although the plenum does contain a compartmentalized structure, some air flow is always present in each of the 13 slots even if one of the three mainframe circulation fans fails to operate. The air passes through the installed modules and escapes out the sides and top of the mainframe.

If any plug-in module exceeds 40 Watts dissipation, you must provide a minimum of 20 mm (0.8 in) of clearance above the mainframe.

A fourth fan provides cooling for the power supply. This fan is mounted on the side of the mainframe.

---

**Caution** When installing the mainframe in your system, ensure that the air inlets and outlets are not obstructed. This prevents damage to the mainframe and installed modules due to overheating. Clean the air filter regularly.

---

## Variable Speed Fan

Normally, the speed of the four internal circulation fans is determined by the ambient temperature of the air drawn into the mainframe. One fan cools the power supply module and three fans cool the VXI modules inserted into the mainframe. You can override the temperature-controlled speed of the fans by changing the position of the Fan Speed Control Switch on the rear of the mainframe to “HIGH”. This forces all four fans to remain at full speed all of the time. The two fan modes are:

- Variable Speed Mode (factory default): Quiet operation (~75% airflow) at <math>30^{\circ}\text{C}</math> ambient temperature. High speed operation at <math>40^{\circ}\text{C}</math> ambient temperature.
- High Speed Mode (switch selectable): Full airflow at all times.

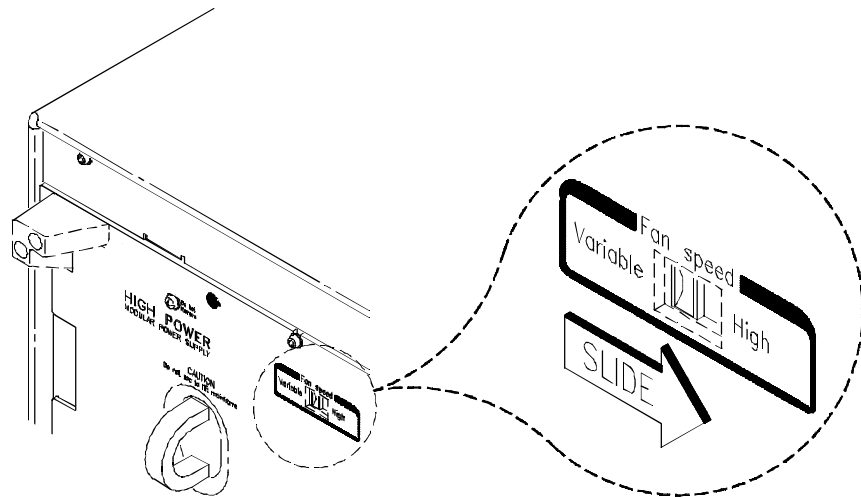
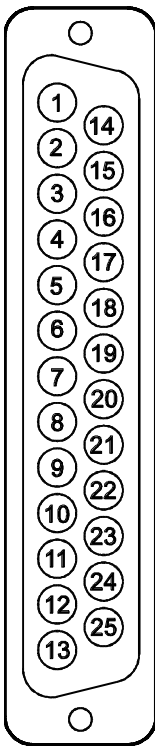

Figure 1-2. Forcing the Fan to High Speed

## Rear Panel Auxiliary Connector

A 25-pin “D” connector is provided on the rear panel of the mainframe to allow monitoring of power supply voltages and other functions. The pinouts for this connector are shown in the following table.



Pin #	Function	Description
1	+5VM	+5V for voltage monitoring (2.4mA max).
2	-12VM	-12V for voltage monitoring (2.4mA max).
3	-24VM	-24V for voltage monitoring (2.4mA max).
4	-2VM	-2V for voltage monitoring (2.4mA max).
5	REM STDBY	Remote Power Switch
6	+5V	+5V output for charging batteries, running external TTL circuits, etc. 1A maximum.
7	+12V	+12V output for charging batteries, running external TTL circuits, relays, etc. 1A max.
8	+5V STDBY	Input for +5V standby current (e.g. from external battery). Max 1A combined total (pins 8 and 21).
9	GND	Chassis Ground
10	SYSRESET*	Backplane SYSRESET* signal (input or output). If you use this pin, be careful not to violate backplane electrical specifications (i.e. keep extender cable as short as possible).
11	EXHAUST_TEMP	An analog output signal proportional to the power supply exhaust temperature.
12	N/C	Not Used.
13	N/C	Not Used.
14	+12VM	+12V for voltage monitoring (2.4mA max).
15	+24VM	+24V for voltage monitoring (2.4mA max).
16	-5.2VM	-5.2V for voltage monitoring (2.4mA max).
17	GND	Chassis Ground
18	REM SW	Remote Power Switch Return
19	GND	Chassis Ground
20	GND	Chassis Ground
21	+5V STDBY	Input for +5V standby current (e.g. from external battery). Max 1A combined total (pins 8 and 21).
22	GND	Chassis Ground
23	AC FAIL*	Backplane ACFAIL* signal (input or output). If you use this pin, be careful not to violate backplane electrical specifications (i.e. keep extender cable as short as possible).
24	GND	Chassis Ground
25	N/C	Not Used.

**+5V** The +5 volt output lets you power external TTL circuitry if required. The maximum current allowed from this supply is 1.0A.

**+12V** The +12 volt output lets you power a battery charging circuit to provide a source for the +5V STDBY input. The maximum current allowed from this supply is 1.0A.

**+5V STDBY** This provides an input to the mainframe backplane for a +5 volt standby power source. This may be from a separate battery or power supply. The maximum current input allowed is 1.0A. This means that all of the standby circuitry in all of the modules mounted in the mainframe can draw a total of 1.0A when active.

**SYSRESET\*** This pin provides an extension of the backplane SYSRESET\* signal. It can be used to monitor for SYSRESET\* or to send SYSRESET\* to the backplane. Shorting this line to ground inputs a SYSRESET\* signal to the system. If you use any extension cable out of the 25-pin D connector on the mainframe rear panel, make certain that you do not violate VXI backplane electrical specifications (i.e. keep the cable as short as possible, or buffer the signal, etc.).

**ACFAIL\*** This pin lets you monitor the ACFAIL\* signal from the backplane. Since this pin is connected directly to the backplane, do not violate VXI backplane electrical specifications (i.e. keep the cable as short as possible, or buffer the signal, etc.).

**EXHAUST\_TEMP** This pin provides an analog output that is proportional to the power supply exhaust temperature. Using this circuit, you can monitor the actual temperature of the power supply exhaust temperature to receive a warning signal that the mainframe is running under abnormal conditions. This output provides 0Vdc at 0°C, with a rise of 10mV per degree centigrade when referenced to chassis ground.



## Remote Standby Switch

The remote standby switch connection is provided to let you turn the mainframe ON or put it in STANDBY mode remotely. These two connections are wired in parallel with the front panel ON/STANDBY switch. This means that the front panel switch must be in STANDBY position for the remote switch to function correctly.

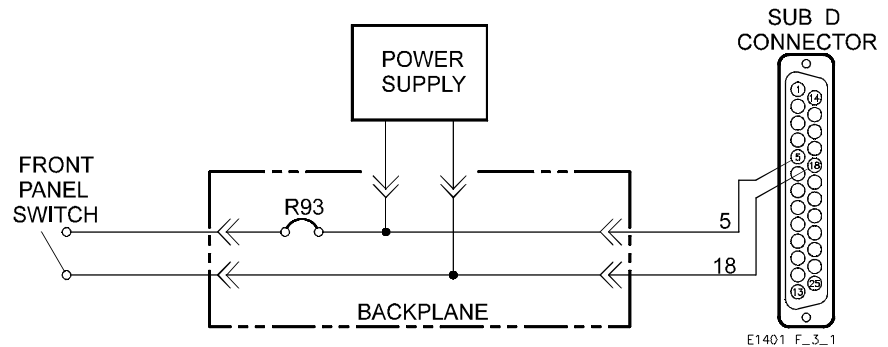

Figure 1-3. Remote Standby Switch Wiring

If you wish to completely disable the front panel switch, you can remove R93 (a surface mount, zero-Ohm resistor) on the back of the backplane PCA. Figure 1-4 shows the location of this resistor. Once R93 is removed, the only way to control power is through a switch connected to pins 5 and 18 of the 25-pin D connector on the rear panel of the mainframe. To access the interface board, remove the power supply.

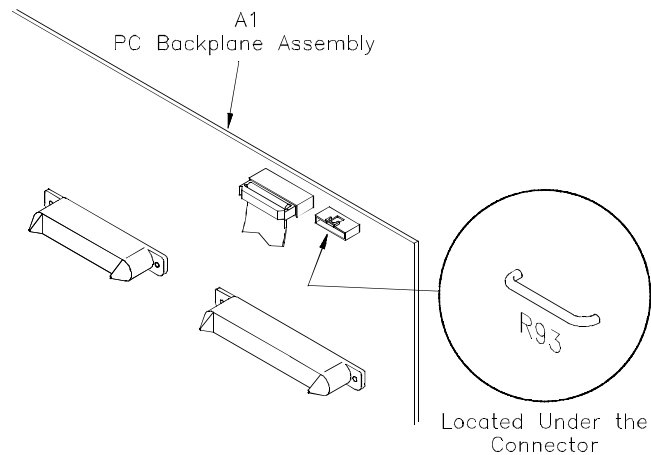

Figure 1-4. Location of R93 Surface Mount Resistor

# Installing the Power Line Fuse

The mainframe is shipped with a 15A fast blow (15AF) fuse (Agilent Part Number 2110-0054) already installed. This fuse is suitable for all line voltages. Figure 1-5 shows how to replace the fuse if necessary.

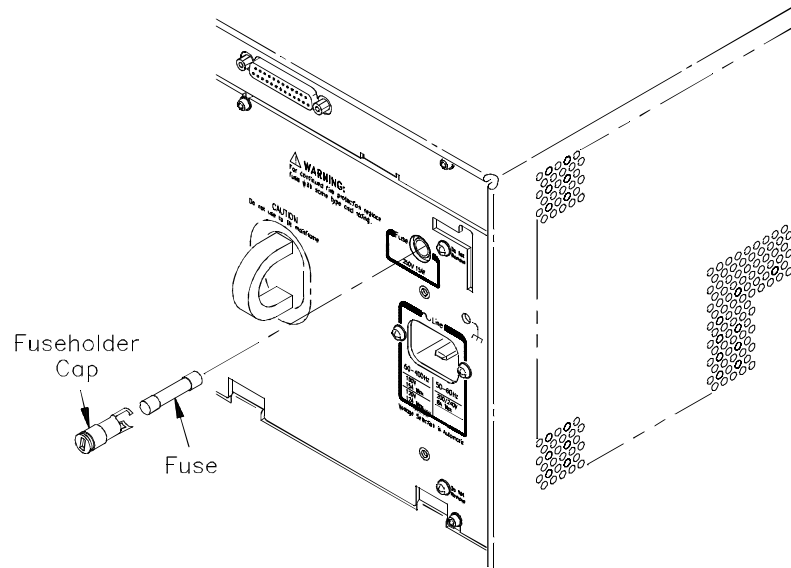

Figure 1-5. Replacing the Power Line Fuse

---

**WARNING** For continued protection against fire hazard, replace fuse only with fuse of specified type and current rating.

---

---

**AVERTISSEMENT** Pour ne pas compromettre la protection contra le risque d'incendie, remplacer le fusible par un fusible de mêmes type et courant nominal.

---

# Power Cords

Table 1-1 shows the power cords and their Agilent part numbers.

**Table 1-1. Power Cords for the Agilent E1401B**

Country	Part Number	Volts	Rated Amps	Type
U.K.	8120-5392	250 VAC	10 A	Right Angle Connector
Australia	8120-5393	250 VAC	10 A	Right Angle Connector
Europe	8120-5394	250 VAC	10 A	Right Angle Connector
U.S./Canada*	8120-5395	125 VAC	13 A	Right Angle Connector
Switzerland	8120-5397	250 VAC	10 A	Right Angle Connector
Denmark	8120-5398	250 VAC	10 A	Right Angle Connector
Japan	8120-5400	125 VAC	15 A	Right Angle Connector

Agilent supplied Power Cords have polarities matched to the power input socket on the instrument:  
L = Line or Active Conductor (also called "live" or "hot"), N = Neutral or identified conductor,  
E = Earth or safety Ground  
\* CSA Certification includes only this power cord.

---

**Note** These are special high power cords. Make certain that any replacement cord is capable of handling the indicated loads.

---

---

**WARNING** For protection from electric shock hazard, power cord ground must not be defeated. The front power switch on this instrument does not disconnect all power from internal circuits. In case of emergency, the operator may need to disconnect the power to this mainframe. Do not block the operator's access to the power cord, or (if installed in a rack) to the circuit breaker which supplies power to the mainframe.

If a remote standby switch is connected to the mainframe by way of the rear panel 25-pin Sub-D connector, then the operator may not be able to turn this unit off by using the front panel switch. Notify the operator of the location of the disconnect device (either the power cord or a circuit breaker) for this mainframe.

---

---

**AVERTISSEMENT** Pour ne pas compromettre la protection contre le choc électrique, ne pas couper le circuit de continuité des masses de la fiche. L'interrupteur avant de cet appareil ne coupe pas la totalité de l'alimentation des circuits internes. En cas d'urgence, l'utilisateur peut devoir débrancher cet appareil. Ne pas bloquer l'accès au cordon d'alimentation ou (si l'appareil est installé sur un châssis) au disjoncteur alimentant l'appareil.

Si un interrupteur de secours a distance est branché à cet appareil au moyen d'un connecteur Sub D à 25 broches du panneau arrière, il est possible que l'utilisateur n'arrive pas à mettre l'appareil hors tension au moyen de l'interrupteur frontal. Avisez l'utilisateur de l'emplacement du dispositif de sectionnement (cordon ou disjoncteur) de l'appareil.

---

# Agilent E1401B Safety Grounding Information

---

**WARNING** For protection from electrical shock when operating at mains frequencies greater than 66 Hz, connect the chassis ground terminal to permanent earth ground.

---

---

**AVERTISSEMENT** Risque de Choc électrique. Si la fréquence du secteur est supérieure à 66 Hz, relier la borne de masse du châssis à une prise de terre fixe.

---

## Grounding Procedure

Connect a 16 AWG (1.3 mm or larger) wire to the PEM nut shown in Figure 1-6. The wire must be green with a yellow stripe or bare (no insulation). Use an M4 x 10 screw, grounding lug, and toothed washers (or toothed lug) as shown in Figure 1-7. Securely attach the other end of the wire to a permanent earth ground using toothed washers or a toothed lug.

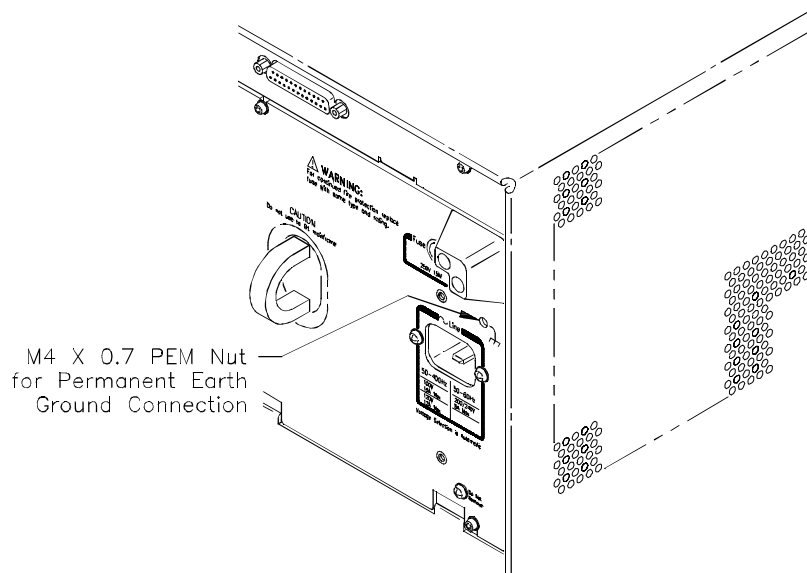

Figure 1-6. Grounding Connection

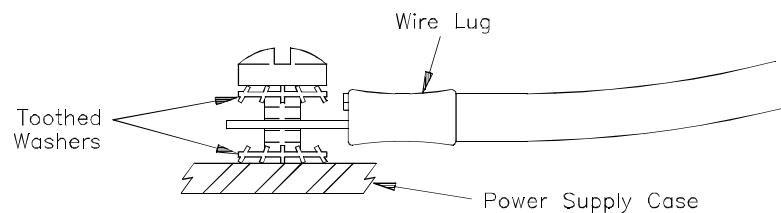

Figure 1-7. Grounding Screw, Toothed Washers

*Notes:*

---

# Replaceable Parts and Assemblies

---

There are no user serviceable parts in the Agilent E1401B. Repair is limited to replacing the power supply module, the backplane module, or other mechanical parts only.

### Module Replacement

The power supply is available on an exchange basis. The backplane assembly should be replaced and not repaired (no exchange on the backplane).

-- Backplane: E1401-66511

-- Power Supply: E1401-69202

### Component Locator

Refer to Figures 2-1 through 2-3 for component locator information.

---

#### WARNING

**There are no user serviceable parts inside. Refer repair and servicing to trained service personnel.**

---

---

#### AVERTISSEMENT

**Ne contient pas d'élément que l'utilisateur puisse réparer. Confier les réparations et la maintenance à un technicien qualifié.**

---

### Cleaning Fan Filters

Remove and clean the mainframe's fan filter regularly (see Figure 2-3).

# Agilent E1401B Replaceable Parts List

Reference Designator	Agilent Part Number	Total Qty.	Description
A1	E1401-66511	1	PC Backplane Assembly
A2	E1401-69202	1	Power Supply; Power-650 Watts; 8 Outputs
B1-B4	3160-0864	4	Fan - Tubeaxial - 12 VDC
BZL1	E1401-04306	1	Front Bezel - Bottom
BZL2	E1401-04304	1	Bezel - Top
BZL3	E1401-04301	1	Front Bezel - Left
BZL4	E1401-04302	1	Front Bezel - Right
CBL1	E1401-61611	1	Cable - Back Plane Interface
CBL2	E1401-61612	1	Cable - Power Switch LED
CBL3	E1401-61610	1	Cable - Fan
CR1	1990-1027	1	LED - Lamp
CVR1	E1401-04110	1	Cover - Top
F1	2110-0054	1	Fuse 15A, 250V NTD FE UL
MP2	E1401-04603	1	Air Filter
MP94	1400-1502	1	Clip - LED Mounting Polypropylene
MP95 - MP97 MP100 - MP102	E1401-81206	6	Horizontal Rail
MP98	E1401-00102	1	Chassis
MP99	E1401-04602	1	Air Plenum
MP103 - MP128	E1401-41202	26	Guide, PC Extractor
MP129	E1401-01211	1	Bracket, Fan
MP130	E1401-00203	1	Fan Carrier (Blank Panel)
MP131	E1401-00204	1	Rear Panel
MP132	E1401-01212	1	Bracket, Power Supply Bottom
MP133	E1401-01213	1	Bracket, Power Supply Top
MP134	E1401-01215	1	Bracket, Air Filter
MP135 - MP136	5001-0543	2	Trim - Side Front Frame
MP137	5021-8411	1	Frame Front
MP138 - MP141	5041-8801	4	Foot
MP142	5041-8802	1	Trim Strip Top
MP143 - MP146	5041-8821	4	Stand-Off Rear Panel
MP149 - MP150	E1401-81205	2	Mounting Rail, Front (uses E1401-21200; 1 per front rail)
	1494-0075	2	Tapped Strip (mounts inside MP97 and MP102)
	E1401-21200	2	Tapped Strip Non-symmetric (mounts inside MP149 - MP150)
PNL2 - PNL4	E1400-00209	3	Filler Panel - 1 Slot
PNL5	E1400-00203	1	Filler Panel - 3 Slot
PNL6	E1400-00204	1	Filler Panel - 7 Slot
X1	2110-0565	1	Fuseholder Cap 15A Max for UL
	E1401-00210	1	EMI Spring Clip

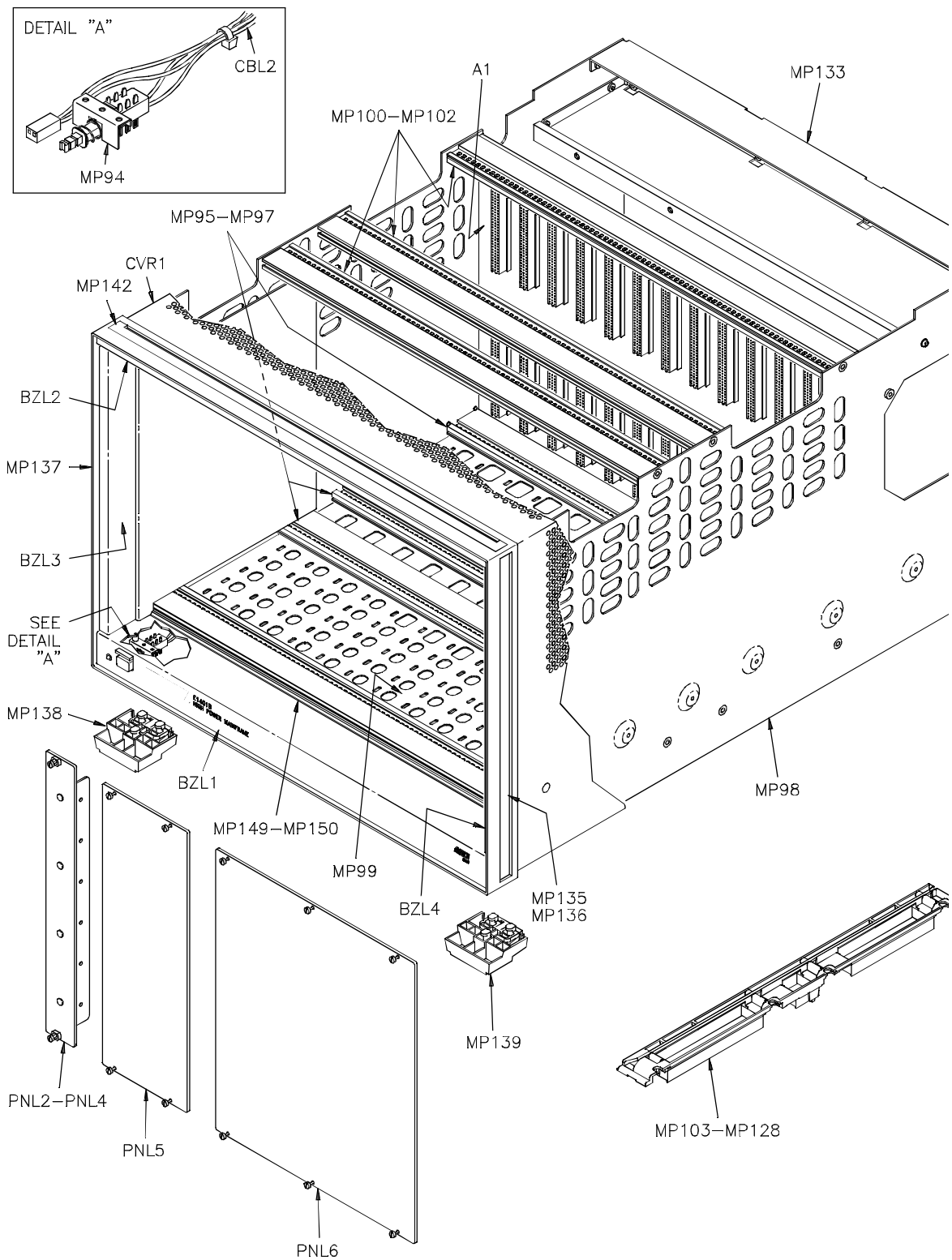

**Figure 2-1. Mainframe Replaceable Parts**



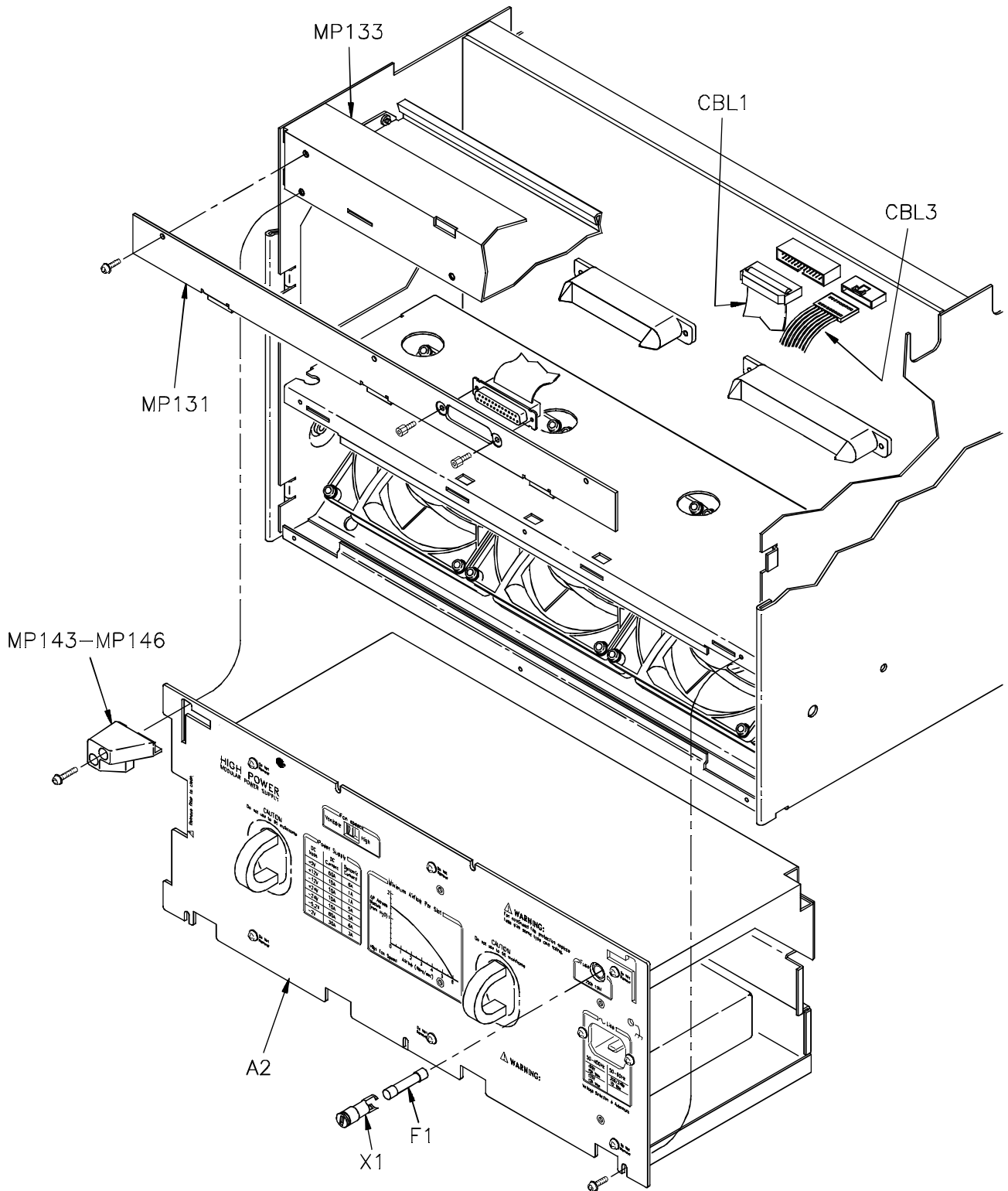
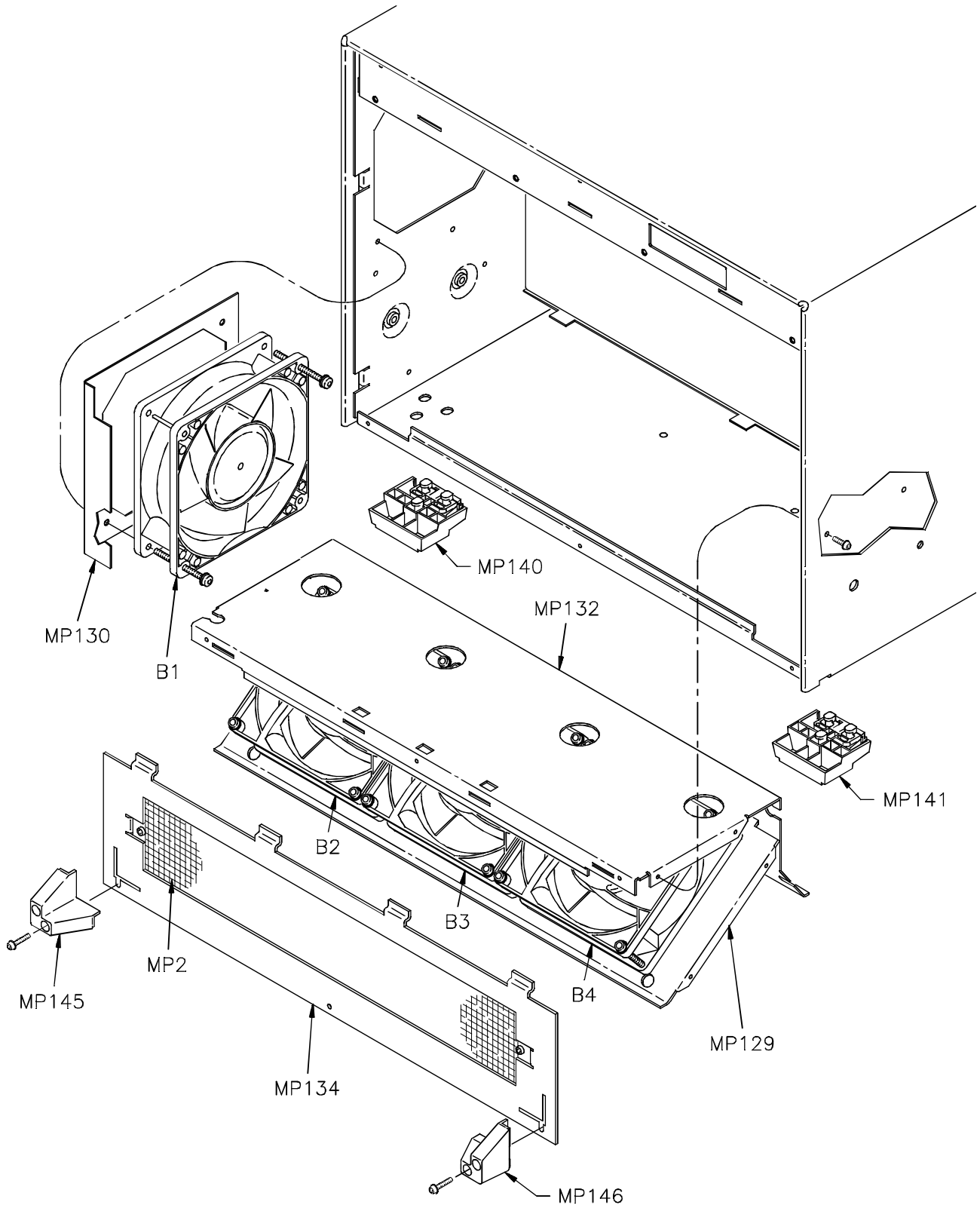

Figure 2-2. Power Supply and Rear Panel Replaceable Parts



**Figure 2-3. Fan Assembly and Rear Panel Replaceable Parts**

*Notes:*

---

# Appendix A

# Agilent E1401B Specifications

---

The Agilent E1401B High-Power mainframes are 100% compatible with VXIbus specification revision 1.4.

### Overall Mainframe Size

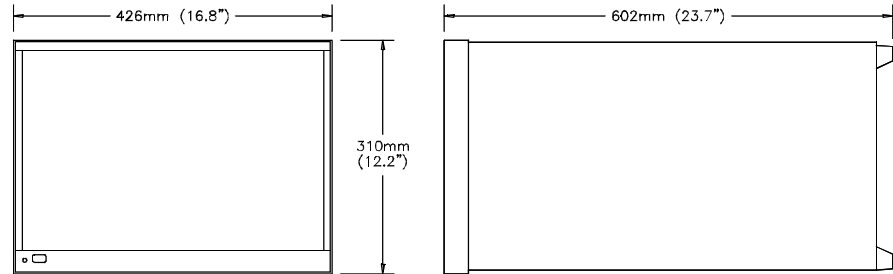

### Mainframe Weight

Agilent E1401B: 22 Kg (48.5 lbs) with no modules installed.

### Module Size

Thirteen (13) C-Size slots. The mainframes also accept A- or B- Size modules using the optional Agilent E1403 Module Carrier.

### Input Power

#### 50 - 60 Hz Input Power:

Automatic Voltage Ranging, nominal range: 100 - 240 Vac  $\pm 10\%$

Nominal Frequency Range: 50 - 60 Hz  $\pm 10\%$

#### 400 Hz Input Power:

Nominal Voltage Range: 100 - 120 VAC  $\pm 10\%$

Nominal Frequency: 400 Hz  $\pm 10\%$

#### DC Input Power:

Input Voltage Range: 100 VDC minimum - 370 VDC maximum

### General Power Supply

Power Factor Corrected

**Power Switch:** On/Standby with lighted indicator in front

Rear panel connection allows remote operation.

**Inrush Current:** 40A max

Designed to meet EN-60555-2

**Socket for detachable line cord:** IEC 320 "HOT"

**Chassis ground tap on rear panel:** M4 x 0.7 threaded insert.

### Fuse:

Voltage	Maximum Current	Fuse
100Vac	15A	15AF
120Vac	12A	15AF
220-240Vac	8A	15AF

## Power Supply Outputs

DC Output Voltage	Peak DC Output Current (*IMP)		P-P Dynamic Current (**IMD)	CD Current Limit (supply shuts down)
	40°C	55°C		
+5V	65A	60A	9.0A	70 - 80A
+12V	14A	12A	2.5A	14 - 18A
-12V	14A	12A	2.5A	14 - 18A
+24V	14A	12A	5.0A	15 - 19A
-24V	12A	10A	5.0A	12 - 16A
-5.2V	65A	60A	8.5A	70 - 80A
-2V	35A	30A	4.5A	35 - 41A

\* IMP = Rated mainframe peak DC output current as defined by the VXIbus Specification.

\*\* IMD = Rated mainframe peak-to-peak dynamic current as defined in the VXIbus Specification by a current vs. frequency curve.

## VXI Ripple/Noise\*

DC Output Voltage	Allowed Variation	Max. DC Load Ripple/Noise	Max. Induced Ripple/Noise
+5V	+0.25/-0.125	50 mV	50 mV
+12V	+0.06/-0.36	50 mV	50 mV
-12V	-0.60/+0.36	50 mV	50 mV
+24V	+1.2/-0.72	150 mV	150 mV
-24V	-1.2/+0.72	150 mV	150 mV
-5.2V	-0.26/+0.156	50 mV	50 mV
-2V	-0.10/+0.10	50 mV	50 mV

\* Per VXI Specification rev. 1.4

## Maximum Power Output\*\*

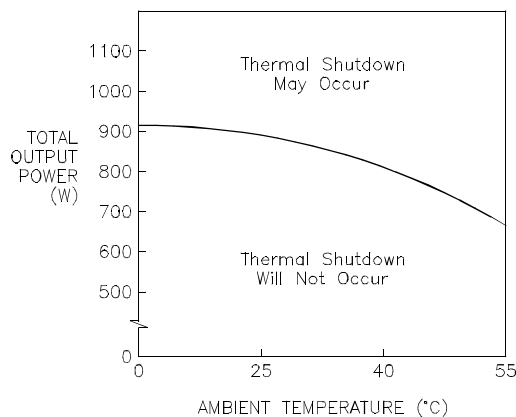

\*\* Uncertainty in shutdown is due to variable loading. Heavy loading on +5V, -2V, and -5.2V will cause shutdown at the lower edge of the band. Heavy loading of the +12V, -12V, +24V, or -24V will cause shutdown at the higher edge of the band. Low line voltage (90Vac) will cause shutdown at the lower edge of the band.

<b>Humidity</b>	Exceeds MIL-T-28800D test limit 3.7.2, 40 °C and 95% RH.
<b>Temperature Range</b>	Exceeds MIL-T-28800D Test Limits 3.7.2, Non-operating: -40°C to +75°C Operating: 0°C to 55°C
<b>Shock and Vibration</b>	Meets the following MIL-T-28800D Test Limits: Vibration test limits: 3.7.4.1 and 4.5.5.3.1 Shock Test Limits: 3.7.5.1 and 4.5.5.4.1 Bench handling test limits: 3.7.5.3 and 4.5.5.4.3

**Cooling Provided**

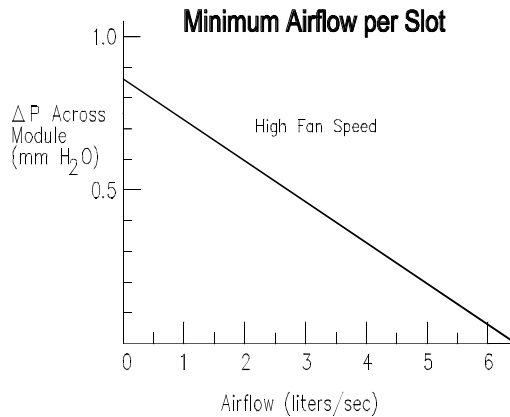

**Fan set to "Variable":** Quiet operation (approximately 75% airflow) at <30°C ambient temperature and high speed operation at >40°C ambient temperature.  
**Fan set to "HIGH":** Full airflow all the time.  
**For modules with typical density:**  
 10°C rise at 60W per slot  
 15°C rise at 75W per slot

**Acoustical Noise**

**Low fan speed:** 48 dBA sound pressure at bystander position.  
 Lpa = 48 dB fiktiver Arbeitsplatz, normalier Betrieb, nach DIN 45635 T.1  
**High fan speed:** 56 dBA sound pressure at bystander position.  
 Lpa = 56 dB fiktiver Arbeitsplatz, normalier Betrieb, nach DIN 45635 T.1

**Classification**

Classified under MIL-T-28800 as Type III, Class 5, Style E, Color R.

**EMC Testing**

Within the requirements of MIL-STD-461 methods CE01, CE02 (relaxed 30 dB below 2 MHz, relaxed 10 dB between 2 and 15 MHz), CS01, CS02, CS06, RE01 (relaxed 10 dB), RE02, and RS02, RS03. Meets requirements of CISPR 11 Level A.

**Module Weight**

Maximum 3.5 Kg (7.7 lbs) per slot to comply with vibration and shock specifications. Heavier modules may be installed if vibration and shock environment is less severe.

**Safety**

IEC 348, UL 1244, and CSA C22.2 #231.

*Notes:*

---

## A

Air Flow, 10

## C

Certification, 3  
Cleaning Fan Filters, 19  
Cooling Provided, 27

## D

Declaration of Conformity, 5  
Documentation History, 4

## F

Filters, cleaning fan, 19  
Fuse, 25  
    installing, 15

## G

General Power Supply, 25  
Grounding Information, 17  
Grounding Procedure, 17

## I

Input Power, 9, 25  
Installing the Power Line Fuse, 15

## L

Line Voltage, 9

## M

Mainframe  
    description, 9  
    size, 25  
    using, 9  
    weight, 25  
Maximum Power Output, 26

## P

Parts List, 20  
Power Cords, 16  
Power Supply Outputs, 26

## R

Rear Panel Auxiliary Connector, 12–13  
Remote Standby Switch, 14  
Replaceable Parts List, 20

## S

Safety Grounding Information, 17  
Safety Warnings, 4  
Specifications, 25–27

## U

Using the Mainframe, 9

## V

Variable Speed Fan, 11  
VXI Ripple/Noise, 26  
VXI*plug&play* Example Programs  
    See VXI*plug&play* Online Help  
VXI*plug&play* Function Reference  
    See VXI*plug&play* Online Help  
VXI*plug&play* Programming  
    See VXI*plug&play* Online Help  
VXI*plug&play* Soft Front Panel  
    See VXI*plug&play* Online Help

## W

WARNINGS, 4



*Notes:*

---