



TEREX
LIGHT CONSTRUCTION

SERIES RL4000D1

LIGHT TOWER

OPERATION/SERVICE

& PARTS MANUAL

After Serial Number :

FOF-15979

PART NUMBER SFMRL4D1
REVISION A
FEBRUARY 2006

TABLE OF CONTENTS

OPERATOR'S MANUAL

To the Operator -----	3
Safety Alert Symbols -----	4
General Safety -----	5-9
Receipt of Delivery Checklist -----	10
Transport & Towing -----	11
Setup -----	12-15
Operating Instructions -----	16-18
Maintenance -----	19-20
Specifications and Dimensions -----	21
Trouble Shooting -----	22-24
Wiring Diagrams -----	25-31
Warranty -----	32-33
Serial Number Record -----	34
Model Number Identification -----	35
Recommended Oil -----	36
Wire Rope Replacement -----	37-38

PARTS MANUAL

General Information Parts Manual -----	39
Parts Ordering Information -----	40
Decal Layout -----	41
Frame Assembly -----	42
Cabinet Assembly -----	43
Tower Assembly -----	44
Control Box and Junction Box -----	45
Ballast Assembly -----	46
Fixture Assembly -----	47
Genset -----	48-49
Radiator Assembly -----	50
Generator -----	51
Hitches -----	52
Options -----	53-60

TO THE OPERATOR

DO NOT ATTEMPT TO SETUP, OPERATE, OR WORK ON THE LIGHT TOWER UNLESS YOU HAVE READ AND STUDIED THIS MANUAL AND THE ENGINE AND GENERATOR MANUALS CAREFULLY. READING THESE MANUALS WILL TEACH YOU HOW TO SAFELY SETUP, OPERATE, AND PROPERLY MAINTAIN THE TOWER AND ITS COMPONENTS.

REMEMBER THAT YOU ARE THE KEY TO SAFETY. GOOD SAFETY PRACTICES NOT ONLY PROTECT YOU, BUT ALSO THOSE WORKING AROUND YOU. MAKE THIS MANUAL A WORKING PART OF YOUR SAFETY PROGRAM.

An operator should never use drugs, alcohol or any other substance which can change his alertness or coordination.

Do not work on this equipment when mentally or physically fatigued.

This manual is compiled from information available and current at time of approval for printing. Terex reserves the right to improve its products without giving prior notice or incurring any obligation.

If this manual becomes lost, order a new one from Terex so future operation and maintenance personnel may read these instructions.

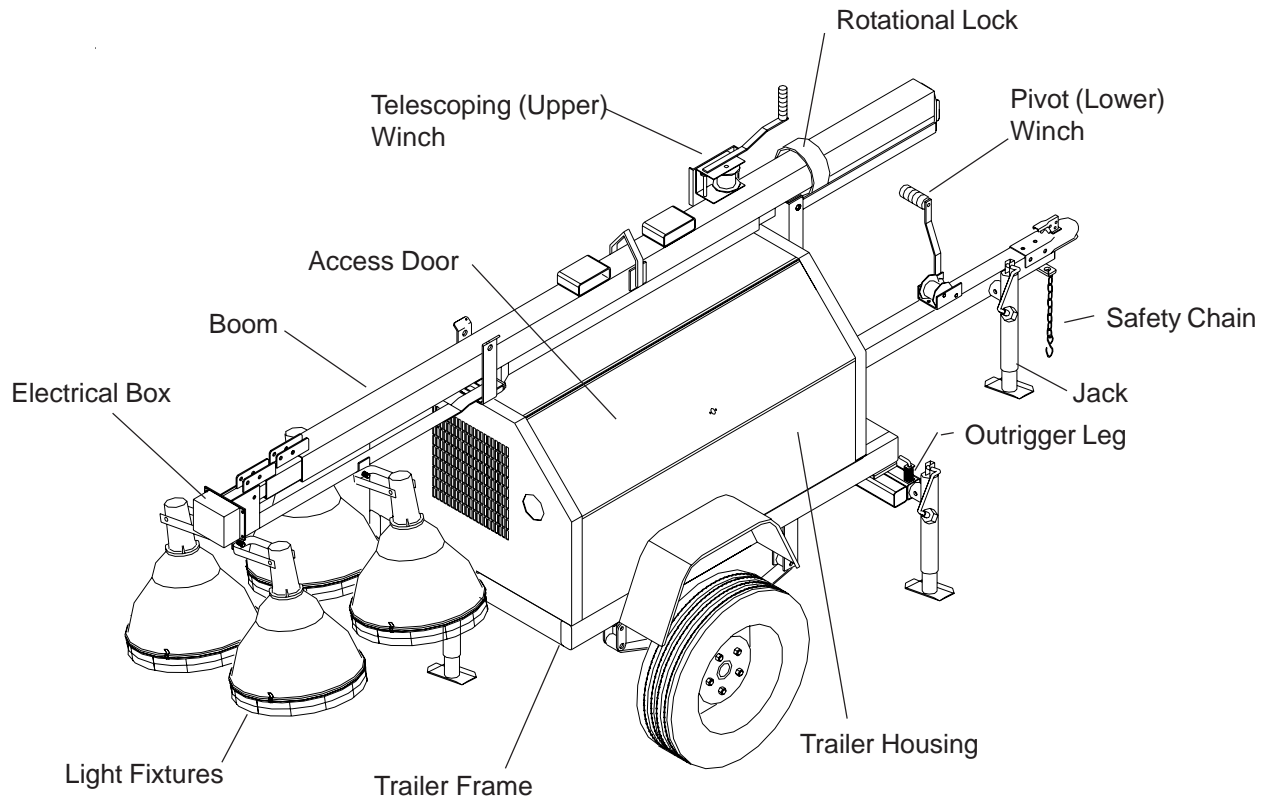

SAFETY ALERT SYMBOLS



**MEANS:
ATTENTION! BE ALERT!
YOUR SAFETY IS INVOLVED**

THIS SAFETY SYMBOL IS USED FOR IMPORTANT SAFETY MESSAGES. WHEN YOU SEE THIS SYMBOL, FOLLOW THE SAFETY MESSAGE TO AVOID PERSONAL INJURY OR PROPERTY DAMAGE.

UNDERSTANDING SIGNAL WORDS

A signal word - **DANGER**, **WARNING** or **CAUTION** is used with the safety alert symbol.



DANGER Identifies the hazard or unsafe practice that will result in severe injury or death.



WARNING Identifies the hazard or unsafe practice that could result in severe injury or death.



CAUTION Identifies the hazard or unsafe practice that could result in minor injury or property damage.



NOTICE Identifies important installation, operation or maintenance information.

GENERAL SAFETY

⚠ WARNING

DO NOT SETUP OR OPERATE THE LIGHT TOWER WITHOUT READING THIS OPERATOR'S MANUAL.

DO NOT WORK ON OR OPERATE THE LIGHT TOWER WHILE UNDER THE INFLUENCE OF PERFORMANCE IMPAIRING DRUGS OR ALCOHOL.



SAFETY ALERT SYMBOL

Stop and take time to read ALL Safety alert messages. Follow the safety messages to avoid personal injury or property damage.



ACCIDENT PREVENTION

Use protective clothing and safety equipment. Always wear approved safety equipment such as gloves, safety boots, safety hard hat, goggles, ear protection, and dust masks when necessary.

Wear protective clothing that is snug and belted where required.

Always wear a hard hat when operating the light tower!



UNAUTHORIZED WELDING

⚠ WARNING UNAUTHORIZED WELDING CAN CAUSE STRUCTURAL FAILURE OR PERSONAL INJURY.

DO NOT weld on any structural member.

Any unauthorized welding or repair procedure will void the warranty.

GENERAL SAFETY



Fuel Fill

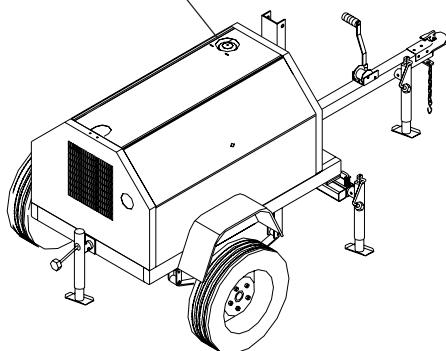

⚠ WARNING FUELING

ALWAYS handle fuel with care. It is highly flammable.

ALWAYS stop engine before refueling. Fill fuel tank outdoors.

Be sure the fuel supply has a positive shut-off valve.

DO NOT replace fuel lines with materials different from those supplied as original equipment.

⚠ CAUTION FIRES CAN CAUSE SEVERE PERSONAL INJURY OR MACHINE DAMAGE.

Prevent fires by keeping the light tower and its surrounding area clean.

DO NOT refuel while smoking or when near open flame or sparks.

DO NOT refuel the engine when it is hot. Allow to cool for several minutes before refueling.

DO NOT spill fuel inside the engine compartment.

If fuel has leaked, wipe it up and have leak repaired before next use.

Have a fire extinguisher nearby. Be sure the extinguisher is properly maintained and be familiar with its use. Extinguishers rated ABC by the NFPA are appropriate for all applications.

GENERAL SAFETY

⚠ WARNING EXHAUST GASES ARE TOXIC. DO NOT USE IN-DOORS UNLESS PROPERLY VENTILATED OR AN EXHAUST SCRUBBER IS USED.

Check exhaust system regularly for leaks and ensure that the exhaust manifolds are secure and not warped.

Make sure the unit is well ventilated.

⚠ WARNING ELECTRICAL SAFETY

This equipment utilizes high voltage circuits. Always exercise extreme caution when trouble shooting or repairing any electrical circuit.

The electrical circuits in this light tower complete their paths back to the generator within the equipment. The neutral conductor at the generator is bonded to the equipment frame. Ground wires within the system are also bonded to the equipment frame.

Always ground the unit when possible.

A grounding lug has been added to the trailer frame for your convenience.

Disconnect electrical power and turn off engine before removing protective covers on high voltage electrical closures.

Beware of a cut or damaged power cord. Have a qualified electrician replace immediately.

When troubleshooting indicates a malfunction in the high voltage AC system, pass the task to a qualified and trained electrician.

⚠ WARNING DO NOT TOUCH HOT PARTS

The exhaust manifold and tail pipe are very hot. Parts of the engine are also hot. Use protective gloves when handling hot parts.

The light fixtures become very hot during operations. To avoid burns, always allow any fixture to cool before handling.

GENERAL SAFETY

⚠ WARNING BATTERY HAZARDS

Lead acid batteries can be dangerous. The sulfuric acid in the battery can cause severe skin and eye burns. The hydrogen gas emitted during charging can explode if an arc or flame is present.

DO NOT smoke while servicing the battery.

DO NOT allow tools to touch battery terminals and create an arc.

Disconnect the negative terminal of the battery when working on the engine or other parts to prevent accidental arcing. Disconnect the negative cable at the end away from the battery.

DO NOT remove the vent caps when charging the battery.

Always wear eye protection when servicing the battery.

If acid gets on skin or eyes, immediately flush under running water and obtain medical attention.

⚠ WARNING METAL HALIDE LAMPS PRODUCE SHORTWAVE ULTRAVIOLET RADIATION AND CAN CAUSE SERIOUS SKIN AND EYE BURNS OR INFLAMMATION IF THE OUTER ENVELOPE OF THE LAMP IS BROKEN OR PUNCTURED.

DO NOT use where people will remain close to the lamps for more than a few minutes unless adequate shielding or other safety precautions are used.

⚠ WARNING KEEP ALL BODY PARTS AND CLOTHING AWAY FROM MOVING PARTS

Loose jackets, shirts, sleeves, and especially neckties should not be worn while working on or running the unit.

Only remove guards or protective devices from unit temporarily to gain access for maintenance. Always replace guards immediately after servicing. Never remove guards while unit is operating.

Keep your hands away from moving parts, particularly clear of the radiator fan and alternator belts when the engine is running.

GENERAL SAFETY

⚠ CAUTION BEWARE OF TRAFFIC HAZARDS

Stand clear of traffic when starting or checking the unit along the road.

Check the fuel tank, oil pan, and fuel and oil lines for leaks that would spill fuel or oil on the road.

Check fasteners and mounting brackets periodically to insure all are tight and nothing is in danger of falling off during transit.

⚠ CAUTION Be careful when lifting. Never suspend any other equipment from the shipping tie downs.

Use the lifting eye or forklift pockets on the tower for lifting the trailer and tower assembly only (with tower and cabinet).

Make sure any tie-downs at the bottom of the trailer are released, and the cradle retaining pin is inserted and secured, prior to lifting.

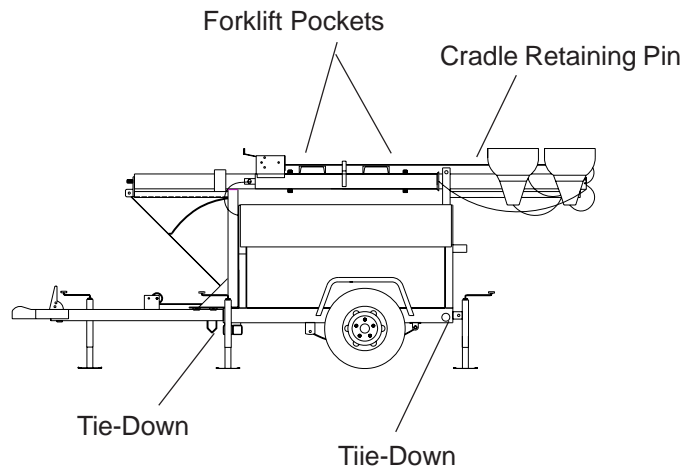

⚠ WARNING NEVER CLIMB ON TOP OF THE CABINET AND/OR TOWER WHEN ERECTED OR RETRACTED.

RECEIPT OF DELIVERY CHECKLIST

The tower will be serviced, tested and ready for operation upon delivery. Terex recommends the following checks:

- () Insure there is no freight handling damage which should be charged against the carrier.
- () Make sure the telescoping boom is secure.
- () Make sure the crosshead assembly is secure.
- () Check the front and rear jacks for security and proper operation.
- () Check the outriggers for security and proper operation.
- () Check that the tires are not damaged, under inflated or that any lugs are loose.
- () Check the engine/generator for obvious damage, loose connections, or leaks.
- () Check the control panel for damage or loose connections.
- () Check the boom wires for obvious damage or loose connections.
- () Check the light fixtures for damage to the lamps, lenses, reflector or etc.
- () Check the winches, cables and pulleys for damage and proper operation.
- () Check the exhaust system for damage.
- () Check all fluid levels; battery, radiator, and engine oils.
- () Insure manuals are in the pocket provided inside the unit.

Transport & Towing

- 1) Using the front leveling jack, securely attach the light tower to the transporting vehicle.
- 2) Insure that the coupler is properly secured to the towing vehicle and attach the safety chains.

⚠ WARNING ALWAYS USE THE PROPER TRAILER HITCH AND SAFETY CHAINS. OBEY ALL LOCAL OR STATE D.O.T. LAWS WHEN TOWING A LIGHT TOWER.

⚠ WARNING FAILURE TO PROPERLY SECURE THE TRAILER TO THE TOWING VEHICLE MAY RESULT IN SERIOUS INJURY OR DEATH.

- 3) Retract and rotate the front leveling jack into its stowed position.
- 4) Check the tires for proper inflation (32psi) and verify the lug nuts are tight.
- 5) Position all outriggers and jacks into the stowed or travel position.
- 6) Verify that the fixtures are secure and ready for transport.
- 7) Secure all loose locking pins and retainers.
- 8) Make sure all doors are closed and tightly locked.
- 9) Remove tire chocks.

⚠ CAUTION Towing of a Terex light tower is approved with the light fixtures in place on the crosshead assembly for all off road terrain and highway towing as long as the following speed limits are followed:
Highway towing- 45 MPH max
Off road towing- 10 MPH max
Severe damage may occur from excessive speeds. Damage created by abuse will void the manufacturer's warranty.

SETUP

A. Move the light tower to desired location keeping the following in mind:

- 1) The light tower should not be placed where those working under the light are either:
 - a. Forced to look into the light regularly.
 - b. Forced to work with there backs to the light (shadows will block the light from the work area).
- 2) The area where the tower is positioned should be relatively level for safe and proper operation of the unit.
- 3) The light tower should be located on the same level or on ground higher than the work area.

B. Use tire chocks in front of and behind each tire whenever possible. Always use tire chocks on an incline.

C. Disconnect the towing chain.

D. Unhitch from the towing vehicle as follows:

- 1) Rotate the tongue jack into position (90 degrees), release the hitch pin and raise the tongue off the towing vehicle.

E. Level the trailer, using the jacks as follows:

- 1) Extend the front outriggers until the outrigger pins lock into place. Rotate the jack on each outrigger into vertical position and lock into place.
- 2) Rotate the rear jack and lock into the vertical position.
- 3) Start at the highest jack position. Rotate the jack handle until the jack foot touches the ground.
- 4) Raise the other jacks to level trailer.

⚠ WARNING OUTRIGGERS ARE NOT DESIGNED TO LIFT THE TIRES OFF THE GROUND.

⚠ CAUTION Insure that all jacks are down to prevent the tower from tipping over backwards when raised.

⚠ WARNING NEVER ATTEMPT TO MOVE THE TOWER WHILE THE LEVELLING JACK ARE DOWN. SERIOUS MACHINE DAMAGE WILL RESULT.

SETUP

F. When applicable, drive grounding rod into earth. (Grounding rod not included)

- 1) Drive the rod into the ground and secure the grounding wire to the lug located on the trailer frame.

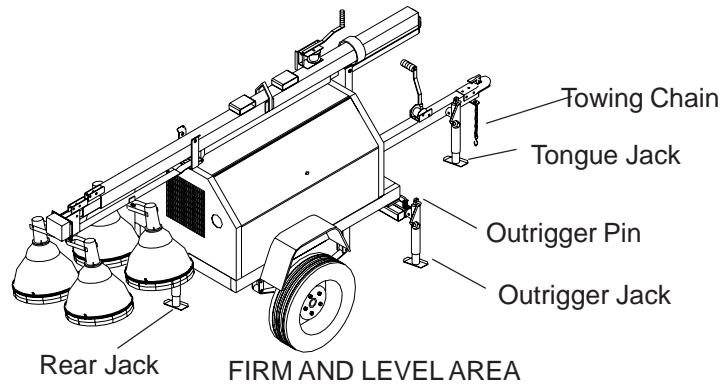

G. When applicable, install the floodlights on the crossarm.

- 1) Remove the light fixtures from their packing boxes and install them on the crossarm with the lens facing the ground.
- 2) The cord on the fixture should be on the side closest to the trailer so the cord entry is beneath the fixture when the tower is raised (this reduces moisture problems and insures the water weep hole in the fixture is down).
- 3) Set the vertical aim for each light fixture by adjusting the light fixtures and tightening the lower bolt.
- 4) Set the spread between the fixtures horizontally by adjusting the fixtures and tightening the mounting nut.
- 5) The light fixtures may be left on the unit when towed around the job site. They can be removed and stowed for highway towing.
- 6) Plug each fixture into the receptacles provided. Plug into the numbered receptacles in a clockwise rotation starting at the upper or 1:00 o'clock position. This makes trouble shooting easy without lowering the tower.

CAUTION

If Tungsten Halogen lamps are used, the cord must be routed and secured away from the fixture. Failure to do so may result in cord burn-through and short circuit due to the high fixture temperature.

SETUP

H. Raising the tower as follows:

- 1) Remove the tower travel locking pin from the cradle at the rear of the cabinet.
- 2) Remove the tower locking pin from the tower base. Using the lower pivot winch, raise the tower to the vertical position. Reinsert the tower locking pin into the tower base.

⚠ CAUTION If there is any difficulty in tilting the boom vertically, check the tailhook and hook. The tailhook may need to be released. Release the tailhook by pushing in on the crosshead assembly until the tailhook is cleared from the hook angle.

⚠ WARNING BEWARE OF PINCH POINTS WHEN ERECTING OR STOWING THE TELESCOPING TOWER. A LOSS OF DIGITS OR LIMBS MAY RESULT FROM UNSAFE PRACTICES.

⚠ CAUTION Do not attempt to lean the tower down below 45 degrees when it is extended - serious damage may occur.

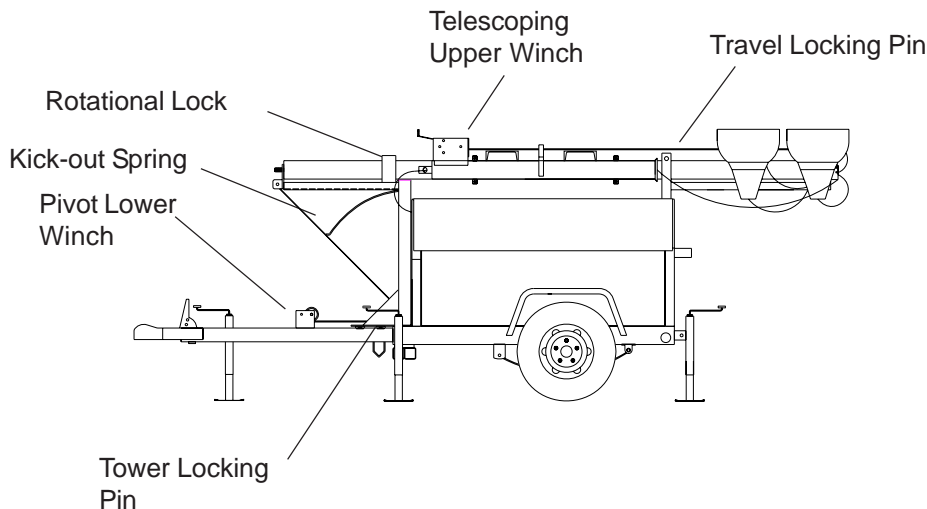

⚠ WARNING WHEN RAISING THE BOOM, MAKE SURE THE BOOM WIRING DOES NOT BECOME ENTANGLED.

SETUP

⚠ WARNING THE AUTOMATIC BRAKE MUST BE WORKING ON THE UPPER TELESCOPING WINCH. THE WINCH SHOULD NOT ALLOW THE TOWER TO DROP DOWN WHEN THE HANDLE IS RELEASED.

⚠ WARNING UNDER NO CIRCUMSTANCES SHOULD THE TOWER BE REPOSITIONED WHEN THE BOOM IS IN A VERTICAL POSITION.

- 4) Release the tower rotational lock and adjust the lights to the desired area. Once positioned correctly, retighten the rotational lock.

OPERATING INSTRUCTIONS

STARTING THE ENGINE/GENERATOR SET

⚠ CAUTION Insure the light switches are turned “off”. This prevents the engine from starting under load and prevents electrical equipment from being damaged.

- 1) Unlock and open the access doors.
- 2) Check the oil, fuel, and coolant levels.
- 3) Check that the tower has been properly grounded.
- 4) Place the key into the ignition switch and preheat the unit for 10-30 seconds.

⚠ CAUTION Never preheat for more than 30 seconds, damage may be done to the heating elements.

- 4) Turn the key switch towards the start side of the key switch. On most units this is towards the right.

⚠ CAUTION To avoid start damage, never operate the starter for more than 45 seconds.

- 5) Start the engine and listen for any unusual sounds or vibrations. Should unusual sounds be detected, contact Terex Light Construction Service Manager.
- 6) Once the engine has been started and running smoothly, place the light switches in the “ON” positions, **one at a time**.
- 7) Check each flood light for proper operation.
- 8) Close and latch the access doors.

NOTICE Vaporous lights require a warm up period of 5-10 minutes before they will produce a full output.

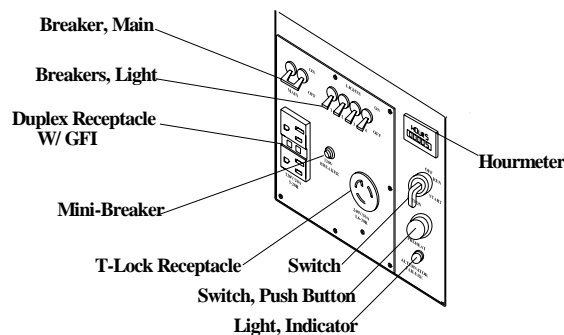

OPERATING INSTRUCTIONS

LIGHT TOWER AUXILIARY POWER:

- 1) One 15 amp, 125 VAC GFI receptacle is provided for auxiliary power.
- 2) Total auxiliary power cannot exceed main circuit breaker rating. Each lamp operating consumes 9.5 amps of 110 volt power.
- 3) Before plugging in auxiliary power cords, feed them up through the trailer frame and attach to receptacles. Close the cabinet doors to protect control panel and other components from weather.

SHUTDOWN PROCEDURES:

- 1) Place all light switches into their "OFF" position.
- 2) Allow the engine to run for 1 to 5 minutes under no load, then turn the unit "OFF".

⚠ CAUTION Never shut the unit down while under load. The AC generator may become damaged.

NOTICE After being shut down, the lights must be allowed to cool down before trying to restart the lights. This cool down period can be between 10-25 minutes, depending on the ambient temperature.

LOWERING THE TOWER:

- 1) Using the upper telescoping winch, telescope the tower down to its fully retracted position.

⚠ CAUTION The boom should lower smoothly and evenly to its lowest position. If it does not, contact a qualified mechanic.

⚠ CAUTION Insure the coil cord does not become entangled with the lower tower sections.

OPERATING INSTRUCTIONS

- 2) Loosen the rotational lock and rotate the tower into its nesting position. The upper telescoping winch should be pointing forward, towards the tongue.
- 3) Remove the travel locking pin (located on cradle).
- 4) Remove the tower locking pin (located on tower base).
- 5) Using the lower pivot winch, lower the tower into the cradle.
- 6) Verify that the tailhook is “latched” or hooked over the tower cradle. This prevents the tower sections from telescoping out while traveling.
- 7) Replace the travel locking pin.
- 8) If required, remove the light fixtures and crosshead assembly.
- 9) Secure all locking pins and verify that the tailhook is properly latched.
- 10) Close and lock both doors.

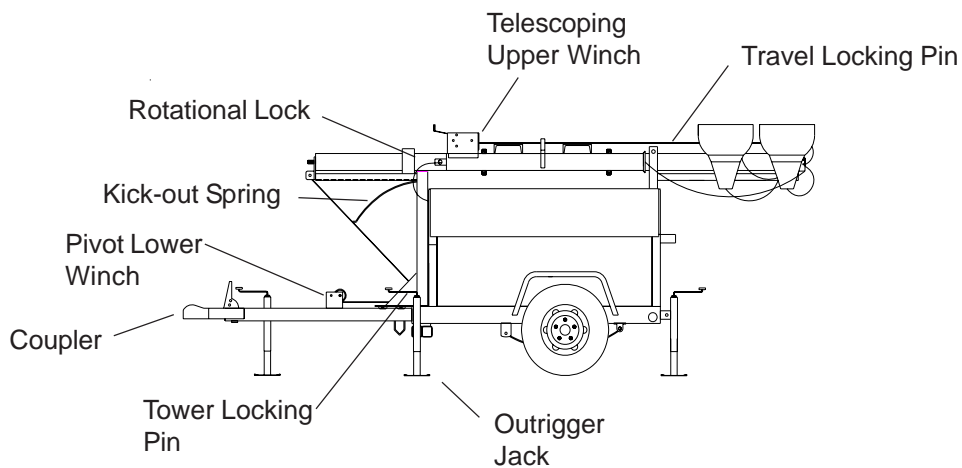

MAINTENANCE

MINIMUM MAINTENANCE PROCEDURES:

The following maintenance intervals are only suggested by Terex. You should always check your engine owner's manual for specific information. Should you find any discrepancies between the Terex Manual and the Engine Manufacturer's Manual always follow the Engine Manufacturer's Manual.

Twice Daily:

- Check the crankcase oil and fill as required.

Daily:

- Check the engine and generator for any loose bolts, connections, and fittings.
- Check the coolant levels and fill as required.

Note: Use a 50% solution of water and antifreeze for the engine coolant.

Weekly:

- Check the air cleaner and clean as required.
- Inspect the radiator fins for damage or clogging.

Bi-weekly:

- Check the engine oil quality and change as required.

Bi-Monthly or every 250 hours:

- Change the engine crankcase oil.

Six months or every 500 hours:

- Replace the oil filter.
- Check valve clearances (consult Manufacturer's Manual)
- Check electrical components and clean as required.
- Check electrical wiring for chafing, wear and replace as needed.

Yearly or every 1,000 hours:

- Clean or replace the fuel filter.
- Clean or replace the fuel pump strainer, if equipped.
- Check the head and manifold bolts for tightness.

MAINTENANCE

CLEANING:

The Light Tower employs various electronic controls that may be damaged by liquid spray washing or high pressure washing. Follow these procedures to prevent any damage to these components.

⚠ WARNING DO NOT SPRAY WATER INTO THE UNIT WHILE IT IS RUNNING. THIS MAY RESULT IN INJURY OR DEATH BY ELECTRIC SHOCK.

Exterior Cleaning:

1. The exterior housing may be washed by most conventional cleaners and methods.
2. The exterior housing may be waxed using any conventional automotive wax.

Interior Cleaning:

1. Using a damp cloth covered with a mild soap, carefully clean around any electric controls, generator, and thermostats.
2. The base and housing foam may be cleaned with a damp cloth covered with mild soap.

Light Fixture Cleaning:

1. The light fixtures and bulbs may be cleaned using any window cleaner.

⚠ WARNING THE LIGHT FIXTURES ARE VERY HOT, ALLOW TO COOL BEFORE PERFORMING ANY CLEANING TO THE FIXTURE, BULBS OR LENSES.

 TEREX LIGHT CONSTRUCTION	Model: RL4000 Light Tower	
	Title: Specifications and Dimensions	

Specifications and Dimensions

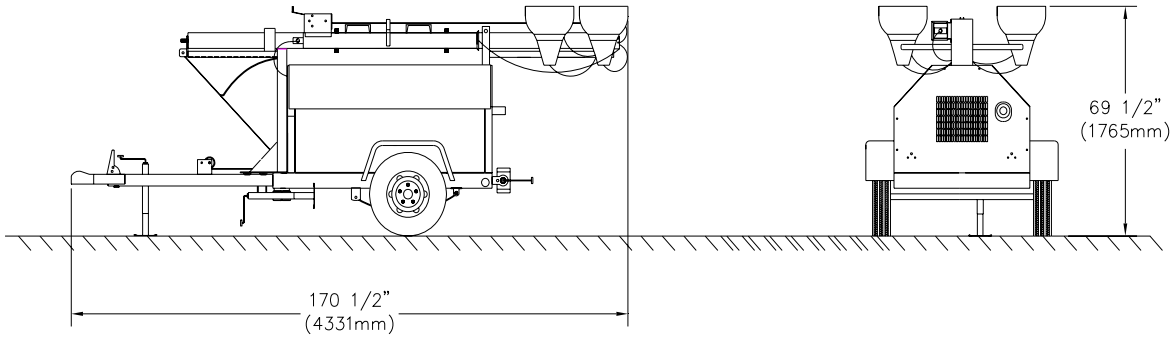

TRAVEL POSITION

NOTES:

- WHEEL SIZE: 13" (330mm)
- AXLE RATING: 2000lbs (907kg)
- TONGUE WEIGHT TRAVEL POSITION: 130lbs (59kg)
- TOTAL WEIGHT, NO FUEL: 1760lbs (798kg)
- FUEL CAPACITY: 27 GAL (102L)

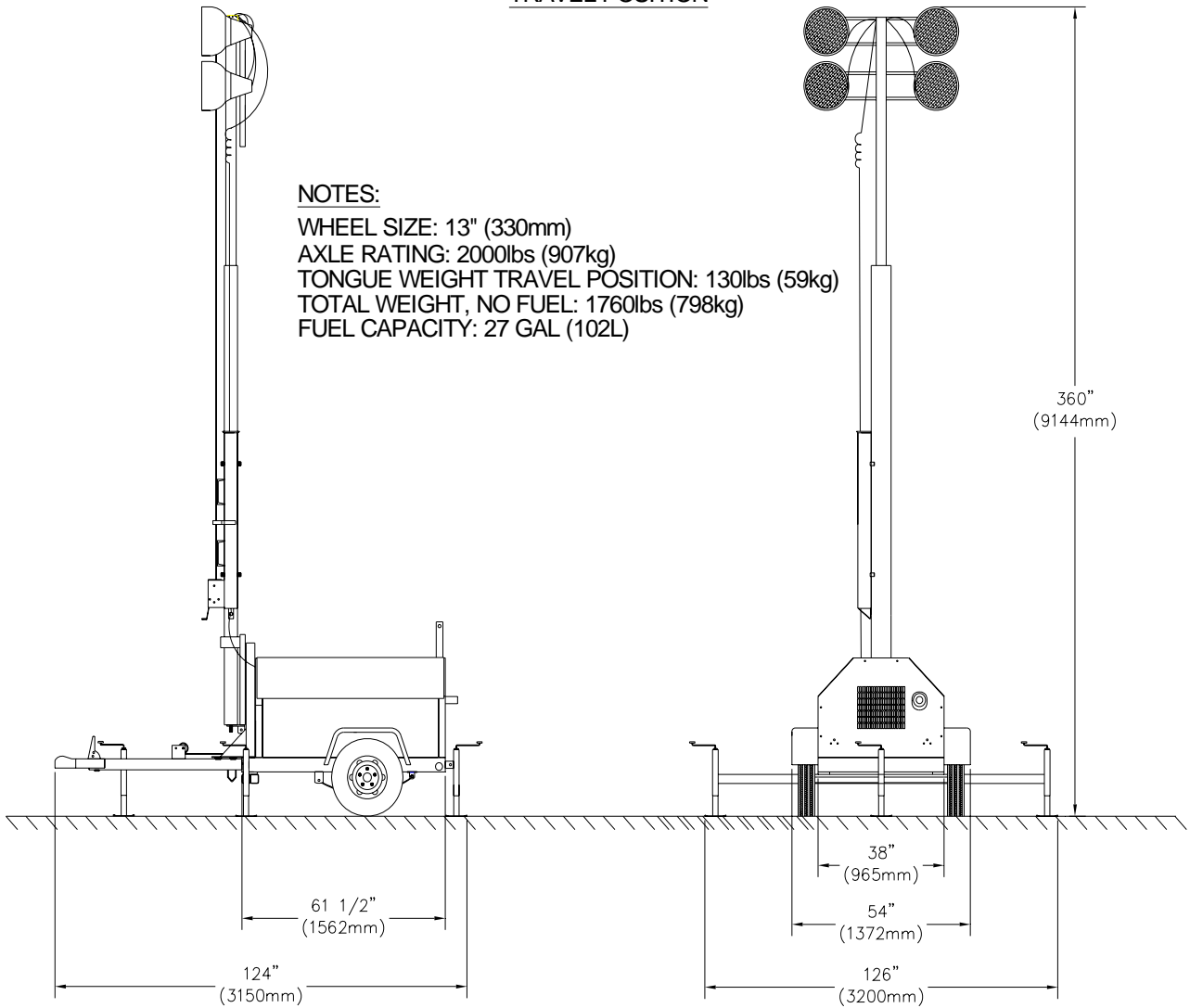

OPERATING POSITION

TROUBLE SHOOTING GUIDE

The engine and generator are set at the factory. These units are tested and set to 1800 RPM at 60 HZ for proper operation in the field. These units should never require additional adjustments in the field. Adjustments should only be made by a qualified service technician, otherwise the manufacturer's warranty may become void.

TROUBLE	POSSIBLE CAUSE	REMEDY
1. Boom will not rise to the operating position.	a. Yoke pin is in place	a. Remove yoke pin
	b. Defective cable or pulley	b. Have a trained mechanic examine and repair as needed
	c. Tailhook is latched	c. Loosen boom cable and push in crosshead assembly
	d. Defective winch	d. Have a trained mechanic examine and replace as needed
2. Boom will not telescope.	a. Defective winch	a. Have a trained mechanic examine and replace as needed
	b. Broken cable or pulley	b. Have a trained mechanic examine and replace as needed
3. Engine will not turn over	a. Dead battery	a. Check the battery voltage or loose cables
	b. Engine has seized due to loss of fluids	b. Have a trained mechanic examine and repair as needed
4. Engine turns over but will not start	a. Empty fuel tank	a. Fill tank with #2 diesel fuel
	b. Clogged fuel lines or filter	b. Check and clean the fuel system as needed
	c. Leaking fuel lines or a loss of prime	c. Replace any leaking fuel lines and tighten connections
	d. Heater elements burned out	d. Replace heater elements
	e. Fuel line solenoid is not open	e. Replace fuel line solenoid
5. Engine runs rough	a. Clogged or leaking fuel system	a. Replace fuel lines, tighten all connections, inspect the pickup tube and inspect the fuel filter
	b. Clogged exhaust system	b. Clear the exhaust system
	c. Clogged air filter	c. Clear air filter
	d. Clogged or stuck fuel injectors	d. Have a trained mechanic examine
	e. Valve clearances are out of adjustment or the valve spring may be damaged	e. Have a trained mechanic examine
	f. Defective governor or fuel pump	f. Have a trained mechanic examine
6. Engine runs but produces a dense smoke	a. Crankcase oil level is too high	a. Drain oil to its proper level
	b. Low compression	b. Have a trained mechanic inspect for broken or seized rings. Inspect valve clearances

TROUBLE SHOOTING GUIDE

7.Engine overheats	a.Blocked cooling air intakes	a.Inspect the front and rear intakes and clear as needed
	b.Low coolant levels	b.Replace the coolant with a 50% water/coolant solution
	c.Radiator fins have become clogged	c.Clear the radiator fins
	d.Fan belt is loose	d.Tighten fan belt
8.Engine runs but the battery voltage is low	a.Alternator has failed	a.Have a trained mechanic inspect the alternator
9.Engine runs but the light will not operate	a.Circuit breakers are tripped	a.Reset the circuit breaker
	b.Loose connections in the wiring system	b.Have a trained electrician inspect the ballast box wiring system
	c.Burned out bulb	c.Replace the bulbs as needed
	d.Defective capacitor (Leroy Somers Generator)	d.Have a trained electrician inspect the capacitor
	e.Defective rectifier (Newage generator)	e.Have a trained electrician inspect the rectifier
	f.Defective AC generator	f.Have a trained electrician inspect the generator
	g.Engine speed is too low	g.Have a trained mechanic inspect the engine speed and reset to 1800rpm @ 60hz
	h.Defective ballast and capacitors	h.Have a trained electrician inspect the ballast and capacitors
10.Unusual noise coming from the generator	a.The generator has a defective bearing or damaged fan blade	a.Have a trained electrician inspect the generator
11.Lamp will not start	a.Lamp loose in socket	a.Inspect lamp base to see if there is arcing at center contact button. Tighten lamp. Check socket for damage. Replace if needed.
	b.Floodlight plugs not tight	b.Check plug and receptacle. Tighten if needed
	c.Defective ballast	c.Interchange ballast plugs. If lamp starts, replace ballast. Check for swollen capacitors, charred wiring, core and coil, or other signs of excessive heat.
	d.Low voltage	d.Check line voltage at ballast input. Voltage should be within 10% of rating when operating at normal load. Increase supply voltage or remove external load.
	e.Improper ballast	e.The ballast name plate data should agree with the line voltage and lamp used. If not, replace the ballast.
	f.Improper lamp operating position	f.Operating position should agree with lamp etch.
	g.Lamp has been operating; cool down time insufficient	g.Switch off breaker and allow lamp to cool.

TROUBLE SHOOTING GUIDE

12. Lamp starts slowly (arc does not strike when switch is first turned on)	a. Defective lamp	a. Lamp may glow for an extended period of time. Replace after checking voltage and ballast
13. Circuit breaker trips on lamp startup	a. Short circuit or ground	a. Check wiring against diagram. inspect for shorts or ground. Fix as needed.
14. Lamp light output low	a. Normal lamp depreciation	a. Replace lamp
	b. Dirty lamp or fixture	b. Clean lamp and fixture
	c. Defective ballast	c. Interchange ballast plugs. If lamp starts, replace ballast. Check for swollen capacitors, charred wiring, core and coil, or other signs of excessive heat.
	d. Wrong voltage	d. Check line voltage at ballast input. Voltage should be within 10% of rating when operating at normal load. Check wiring connections for voltage loss. Check socket contact point.
	e. Improper ballast	e. Check ballast name plate against lamp data
15. Lamp colors different	a. Normal lamp depreciation	a. Replace lamp
	b. Dirty lamp or fixture	b. Clean lamp and fixture
	c. Wrong lamp	c. Check data on lamps and replace as needed.

⚠ WARNING

IF YOU FEEL AN ELECTRIC SHOCK AT ANY TIME WHILE OPERATING THIS UNIT, SHUT IT DOWN IMMEDIATELY! HAVE THE UNIT INSPECTED BY A TRAINED ELECTRICIAN.

⚠ DANGER

DO NOT OPEN FIXTURES WHILE LIGHT CIRCUIT IS "ON".

⚠ DANGER

NO USER SERVICEABLE PARTS INSIDE! THIS IS ONLY A GUIDE. UNIT TO BE SERVICED BY A QUALIFIED ELECTRICIAN!

PART # WD2985		DWG. # 2985A	
ITEM #	PART #	DESCRIPTION	#REQ

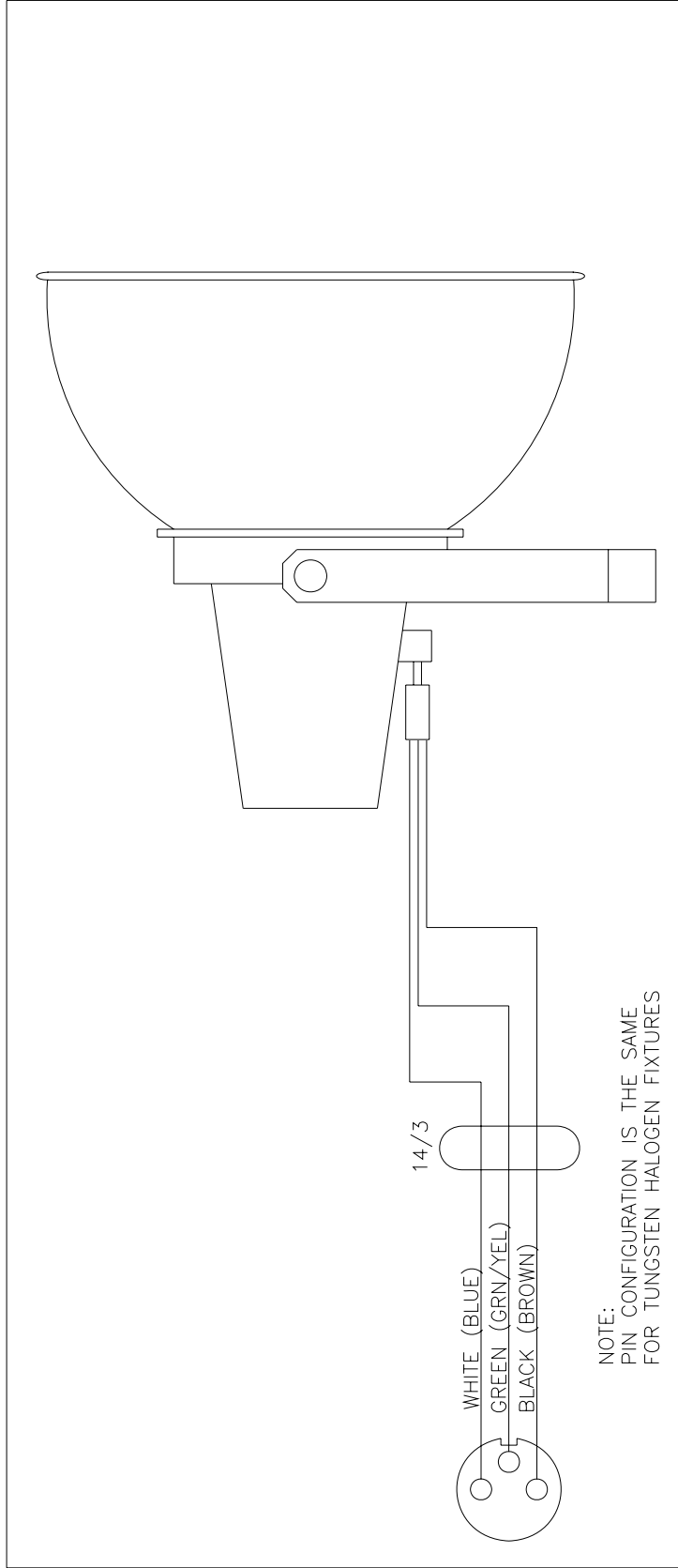

REV. A	3/15/00	ECO #	ADDED EUROPEAN (CE) WIRING DATA
TOLERANCES UNLESS OTHERWISE SPECIFIED:		CHANGE	
Decimals	.XX=±0.30	.XXX=±0.10	
Fractions	±1/16	.XXXX=±0.005	
Degrees	±1/2°		
REMOVE ALL BURRS & SHARP EDGES			
MATERIAL		W/JOY CONNECTOR BORDER "B"	
MAT P/N	USAGE	DR BY CNM	APP BY
PLOT 4/30/91	DATE 4/30/91	SCALE NONE	
		PART # WD2985	DWG. # 2985A

DOMESTIC COLOR CODE	EUROPEAN COLOR CODE	CIRCUIT
WHITE	LIGHT BLUE	COMMON FROM BALLAST
BLACK	BROWN	HOT FROM BALLAST (LIVE)
GREEN	GREEN W/YELLOW	GROUND (EARTH)

PART # WD2986		DWG. # 2986
ITEM #	PART #	DESCRIPTION
		#REQ

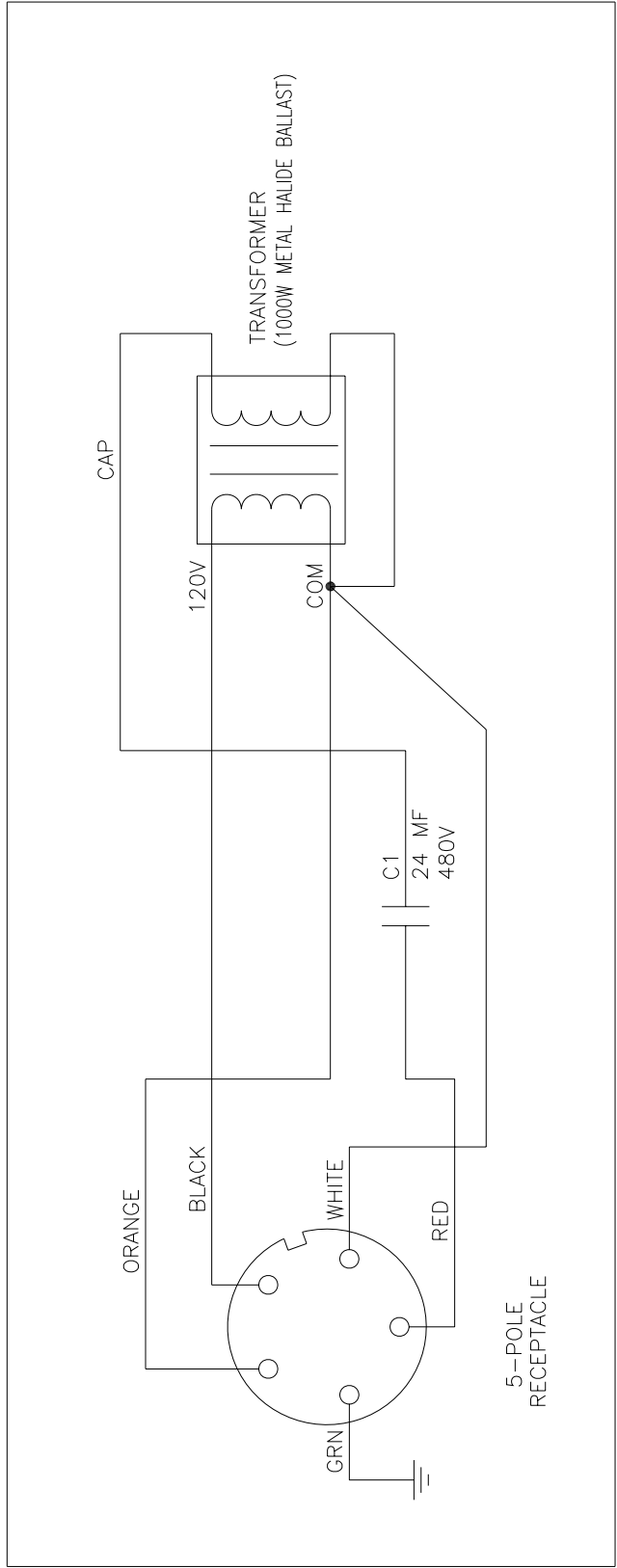

5-POLE
RECEPTACLE

COLOR	CIRCUIT
BLACK	INPUT 120V
WHITE	INPUT COMMON
RED	LAMP HOT
ORANGE	LAMP COMMON
GREEN	GROUND

REV.	DATE	ECO #	CHANGE
TOLERANCES UNLESS OTHERWISE SPECIFIED: Fractions ±1/16 Decimals .XX=±0.050 .XXX=±0.010 .XXXX=±0.005 Degrees ±1/2° REMOVE ALL BURRS & SHARP EDGES MATL. W/JOY CONNECTOR BORDER "B"			
Terex 590 HUEY Rd, ROCK HILL, S.C. Ph. (803) 324-3011 FAX 366-1101 WIRING DIAGRAM-1000MH BALLAST			
DR BY CNM		APP BY	SCALE NONE
PLOT 4/30/91		DATE 4/30/91	PART# WD2986
DWG.# 2986			

ENGINE COMPONENTS

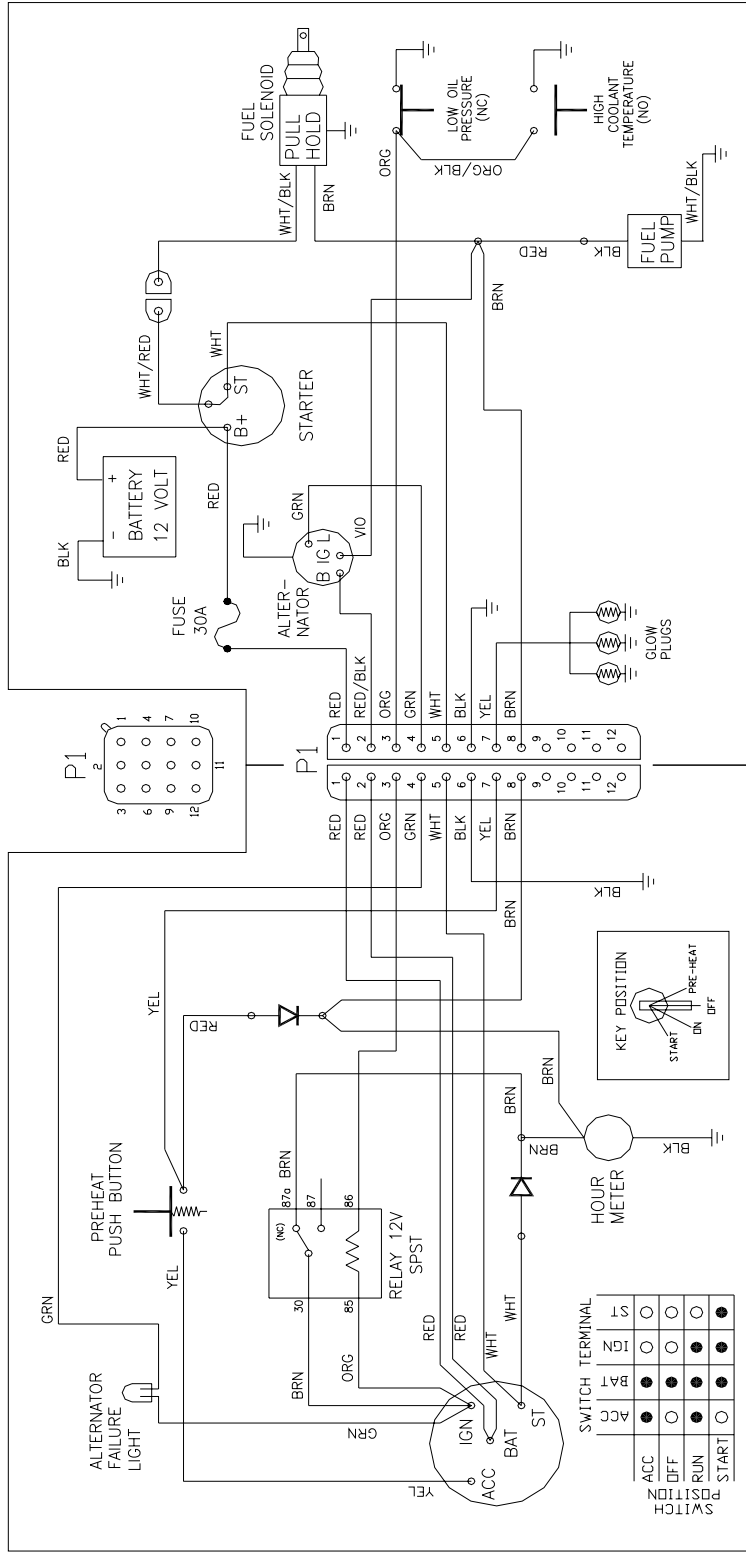

CONTROL BOX

Tolerance Specifications:
 Fractions ±1/16
 Decimals .XX±0.030 .XXX±0.010
 .XXXX±0.005
 Degrees ±1/2°

REVISIONS:

REV.	DATE	ECO #	CHANGE
G	12/22/04	-	REVISED TO MATCH PRODUCTION MODELS
F	9/12/02	-	ADDED CIRCUIT AND DIODES FOR NEW KUBOTA SOLENOID
E	1/12/01	-	ADDED DIODE FOR FUEL PUMP/ PRIME

Terex-amida
 590 HUEY Rd, ROCK HILL, S.C.
 Ph. (803) 324-3011 FAX 366-1101
 WD - DC ENGINE WIRING, KUBOTA
 D905, AL4, AL5, TX3 BORDER "B"
 DR BY JCS APP BY SCALE N/A
 PLOT B 3/23/00 DATE 3/23/00 PART# WD4730 DWG.# 4730G

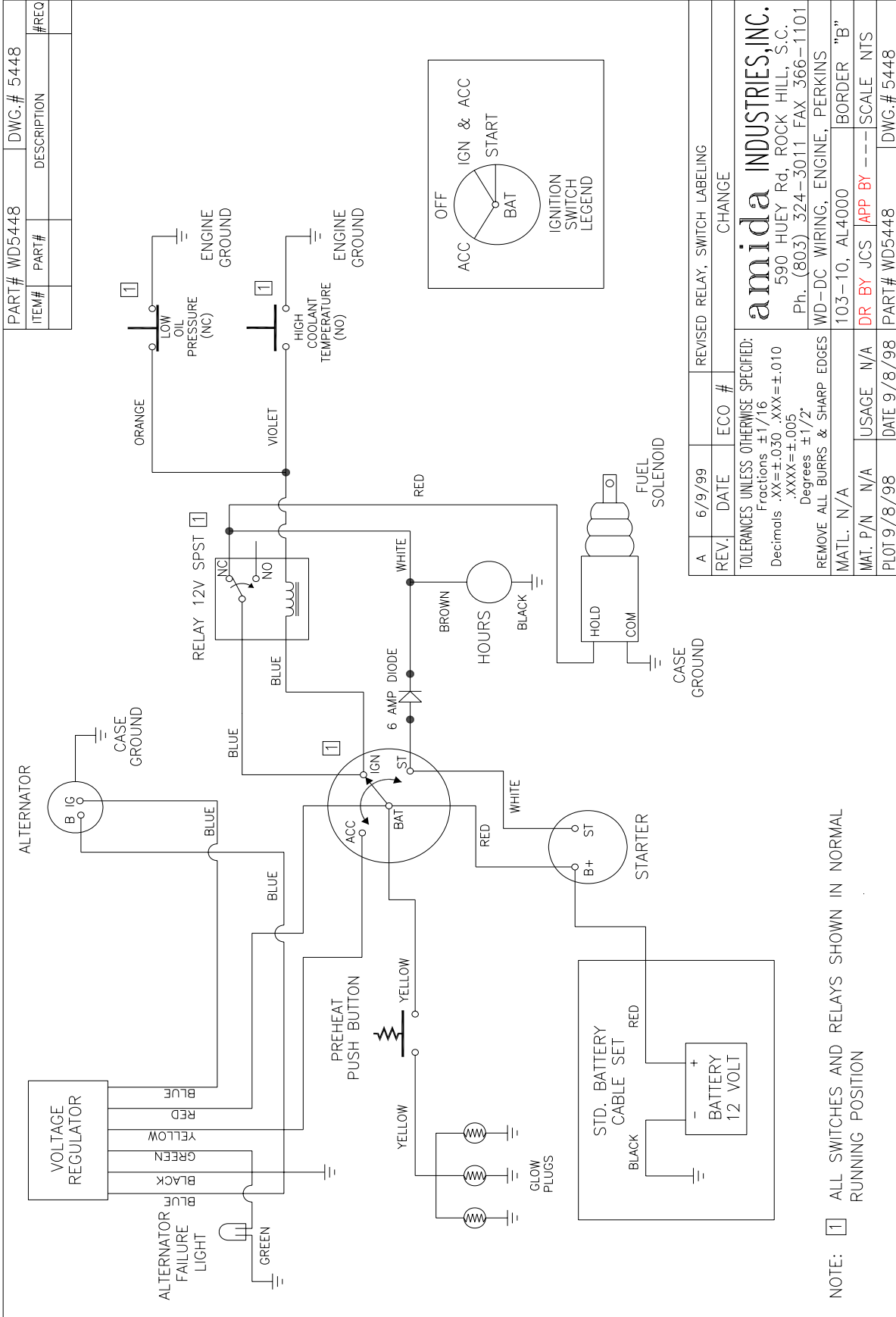

PART #	WD5448	DWG. #	5448
ITEM #	PART #	DESCRIPTION	#REQ

REV. DATE	ECO #	REVISED RELAY, SWITCH LABELING
A	6/9/99	CHANGE
TOLERANCES UNLESS OTHERWISE SPECIFIED: Fractions ±1/16 Decimals .XX=±0.30 .XXX=±0.10 .XXXX=±0.005 Degrees ±1/2° REMOVE ALL BURRS & SHARP EDGES MATL. N/A MAT. P/N N/A USAGE N/A DATE 9/8/98		
amida INDUSTRIES, INC. 590 HUEY Rd, ROCK HILL, S.C. Ph. (803) 324-3011 FAX 366-1101 WD-DC WIRING, ENGINE, PERKINS 103-10, AL4000 BORDER "B" DR BY JCS APP BY --- SCALE NTS PART# WD5448 DWG.# 5448		

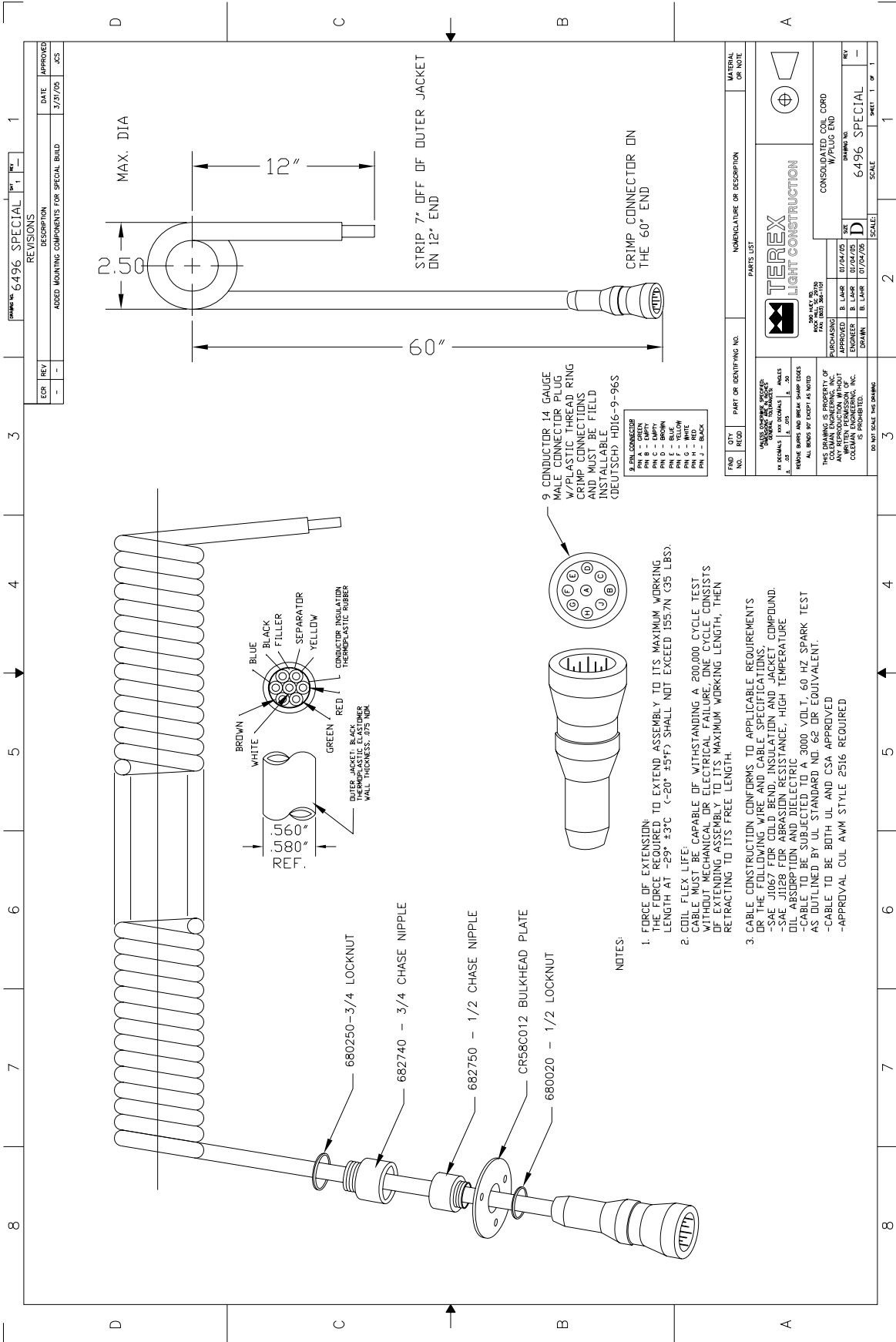

REV		DESCRIPTION	DATE	APPROVED
1		ADDED MOUNTING COMPONENTS FOR SPECIAL BUILD	3/27/05	JCS

PKG	QTY	PART OR IDENTIFYING NO.	PARTS LIST	NOMENCLATURE OR DESCRIPTION	MATERIAL OR NOTE

TEREX LIGHT CONSTRUCTION		CONSOLIDATED COIL CORD W/PLUG END	
APPROVED	DATE	APPROVED	DATE
ENGINEER	DATE	ENGINEER	DATE
DRAWN	SCALE	DRAWN	SCALE

PKG	QTY	PART OR IDENTIFYING NO.	PARTS LIST	NOMENCLATURE OR DESCRIPTION	MATERIAL OR NOTE

TEREX LIGHT CONSTRUCTION		CONSOLIDATED COIL CORD W/PLUG END	
APPROVED	DATE	APPROVED	DATE
ENGINEER	DATE	ENGINEER	DATE
DRAWN	SCALE	DRAWN	SCALE

PKG	QTY	PART OR IDENTIFYING NO.	PARTS LIST	NOMENCLATURE OR DESCRIPTION	MATERIAL OR NOTE

TEREX LIGHT CONSTRUCTION		CONSOLIDATED COIL CORD W/PLUG END	
APPROVED	DATE	APPROVED	DATE
ENGINEER	DATE	ENGINEER	DATE
DRAWN	SCALE	DRAWN	SCALE

PKG	QTY	PART OR IDENTIFYING NO.	PARTS LIST	NOMENCLATURE OR DESCRIPTION	MATERIAL OR NOTE

TEREX LIGHT CONSTRUCTION		CONSOLIDATED COIL CORD W/PLUG END	
APPROVED	DATE	APPROVED	DATE
ENGINEER	DATE	ENGINEER	DATE
DRAWN	SCALE	DRAWN	SCALE

PKG	QTY	PART OR IDENTIFYING NO.	PARTS LIST	NOMENCLATURE OR DESCRIPTION	MATERIAL OR NOTE

TEREX LIGHT CONSTRUCTION		CONSOLIDATED COIL CORD W/PLUG END	
APPROVED	DATE	APPROVED	DATE
ENGINEER	DATE	ENGINEER	DATE
DRAWN	SCALE	DRAWN	SCALE

PKG	QTY	PART OR IDENTIFYING NO.	PARTS LIST	NOMENCLATURE OR DESCRIPTION	MATERIAL OR NOTE

TEREX LIGHT CONSTRUCTION		CONSOLIDATED COIL CORD W/PLUG END	
APPROVED	DATE	APPROVED	DATE
ENGINEER	DATE	ENGINEER	DATE
DRAWN	SCALE	DRAWN	SCALE

DRAWING NO.	6549	REV.	1
DATE	1/10/50	DESCRIPTION	
BY		APPROVED	

ENGINE COMPONENTS

CONTROL BOX

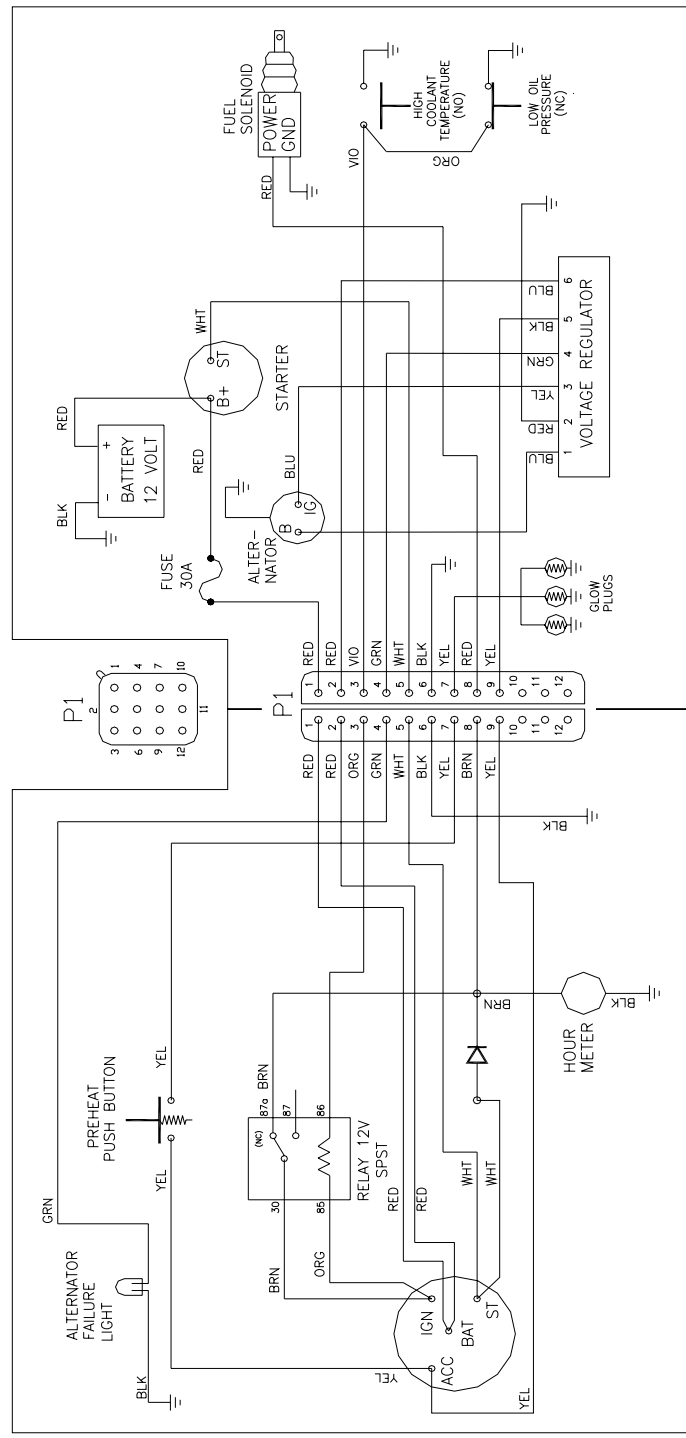

SWITCH	TERMINAL	ACC	OFF	RUN	START
1	1	●	○	○	○
2	2	○	○	○	○
3	3	○	○	○	○
4	4	○	○	○	○
5	5	○	○	○	○
6	6	○	○	○	○
7	7	○	○	○	○
8	8	○	○	○	○

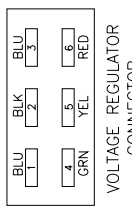
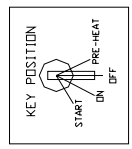

THIS DRAWING IS PROPERTY OF
 COLEMAN ENGINEERING, INC.
 ALL RIGHTS ARE RESERVED. NO PART
 OF THIS DRAWING IS TO BE REPRODUCED
 OR TRANSMITTED IN ANY FORM OR BY
 ANY MEANS, ELECTRONIC OR MECHANICAL,
 INCLUDING PHOTOCOPYING, RECORDING,
 OR BY ANY INFORMATION STORAGE AND
 RETRIEVAL SYSTEM, WITHOUT THE WRITTEN
 PERMISSION OF COLEMAN ENGINEERING, INC.

REV.	DATE	DESCRIPTION
1	1/10/50	REVISED

APPROVED	DATE	BY
ENGINEER	1/10/50	
DRAWN	1/10/50	

PURCHASING	DATE	SCALE
	1/10/50	1 OF 1

TEREX LIGHT CONSTRUCTION	AL LIGHT TOWER WIRING SCHEMATIC - PERKINS
DRAWING NO. 6549	

WARRANTY PROCEDURE

The specific language of this warranty will determine TEREX LIGHT CONSTRUCTION's obligation in connection with its product. The information presented below should be used as a general guide for implementation of policy. In the event of a component failure during the warranty period it should be repaired as soon as possible, preferably at an authorized TEREX LIGHT CONSTRUCTION service center. If component is manufactured by a company other than TEREX LIGHT CONSTRUCTION, such as Deutz, Honda, Isuzu, Leroy Somer, Lister Petter, Lombardini, Wisconsin, etc., the applicant should pursue repair and/or reimbursement through that manufacturer, and its dealer/distributor network.

To file a claim with TEREX LIGHT CONSTRUCTION, an **APPLICATION FOR WARRANTY ADJUSTMENT (AWA)** form must be completed in it's entirety. Return the completed form within fourteen days of the repair to:

**ATTENTION: WARRANTY
TEREX LIGHT CONSTRUCTION
590 Huey Road
Rock Hill Industrial Park
Rock Hill, SC 29730**

TEREX LIGHT CONSTRUCTION will review the AWA form. Should we desire to inspect the defective parts, we will issue you a return authorization for the defective parts. After inspecting the defective part(s), and it is determined that warranty is due, we will then, at the discretion of TEREX LIGHT CONSTRUCTION , credit the applicants account or send replacement parts.

TEREX LIGHT CONSTRUCTION warranty reimbursements:

1. \$40.00 for each hour's labor we allow toward a repair.
2. Distributors cost of parts not more than the price currently available from TEREX LIGHT CONSTRUCTION.
3. One way surface freight charges on parts returned to TEREX LIGHT CONSTRUCTION.

Many repairs are assigned a predetermined labor schedule which is an average time in which a skilled technician should be able to make a repair. TEREX LIGHT CONSTRUCTION will reimburse not to exceed the predetermined number of hours for a particular repair.

TEREX LIGHT CONSTRUCTION does not reimburse for:

1. Travel, travel time, nor travel labor.
2. Mileage.
3. Excessive diagnostic time.
4. Repairs of defects, malfunctions, or failures resulting from accidents, abuse, misuse, modifications, alterations, improper servicing or lack of performance of required maintenance service.
5. Repairs where defective parts were not shipped back when requested by TEREX LIGHT CONSTRUCTION.
6. Regular maintenance such as parts or labor for oil changes, filter changes or filters.
7. Repairs where defective parts were not received by TEREX LIGHT CONSTRUCTION after TEREX LIGHT CONSTRUCTION issued a return authorization.

TEREX Light Construction P.O.Box 3147• Rock Hill, S.C. 29731 USA • Phone 803-324-3011 • Fax 803-366-1101

TEREX LIGHT CONSTRUCTION

P.O. Box 3147
Rock Hill, S.C. 29732

MANUFACTURER'S LIMITED WARRANTY

TEREX LIGHT CONSTRUCTION ("TLC") warrants to the original purchaser that such equipment, accessories, parts and other products manufactured by TLC will be free from defects in workmanship and material for a period of one (1) year after the date of first delivery or for one thousand (1,000) hours of use, whichever comes first; provided that Buyer sends TLC notice of such defect within thirty (30) days of its discovery. Should defects be discovered, the Buyer must clearly establish that (I) the equipment, parts, etc. have been properly installed and set up, maintained and operated within the limits of rated and normal usage and (II) the defect did not result in any manner from the intentional or negligent action or inaction of Buyer. Buyer must also return the defective item or items to TLC, Rock Hill, SC for inspection at TLC's request. If Buyer cannot establish that conditions (I) and (II) have been met, then this warranty shall not cover the alleged defect. Failure to give notice of defect within such period shall be a waiver of this Warranty and any assistance rendered thereafter shall not extend or revive it. **THIS WARRANTY IS LIMITED TO THE BUYER AND IS NOT ASSIGNABLE OR OTHERWISE TRANSFERABLE.**

TLC MAKES NO WARRANTY WITH RESPECT TO PARTS, COMPONENTS, EQUIPMENT AND ACCESSORIES NOT MANUFACTURED BY TLC SUCH AS FIXTURES, BALLASTS, ENGINES, HYDRAULIC PUMPS, FUEL PUMPS, ALTERNATORS, GENERATORS, WINCHES, TIRES AND ELECTRICAL COMPONENTS. Accessories, assemblies and components included in products of TLC, which are not manufactured by TLC, are subject only to the warranty of their respective manufacturers. TLC makes no other warranty, express or implied, and makes no warranty of merchantability or fitness for any particular purpose. This warranty shall not cover misuse, alteration, abuse, negligence, accident, acts of God, sabotage or any item in which serial numbers have been altered, defaced or removed, but shall be limited to repair or replacement of those parts which, upon inspection by TLC, appear to have been defective in material or workmanship.

TLC's liability and Buyer's sole and exclusive remedy for a failure of goods to perform as warranted and/or for any and all other claims arising out of the purchase and use of the goods, including negligence on the part of TLC, shall be limited to the repair or replacement of defective parts returned, transportation prepaid to TLC. TLC shall in no event be liable for incidental or consequential or other damages or losses resulting from a breach of warranty such as, but not by way of limitation, labor costs, loss of profits, loss of use of other than equipment, third party repairs, personal injury, emotional or mental distress, improper performance of work, penalties of any kind, loss of service of personnel, or any other damages or losses which may be experienced by the Buyer.

A product warranty certificate must be filled out in its entirety and returned to TLC in order to process any warranty claims submitted.

THIS WARRANTY IS EXPRESSLY IN LIEU OF AND EXCLUDES ALL OTHER WARRANTIES, EXPRESSED OR IMPLIED (INCLUDING ANY WARRANTY OF MERCHANTABILITY AND FITNESS OF ANY PRODUCT OR GOODS FOR A PARTICULAR PURPOSE) AND ALL OTHER OBLIGATIONS OR LIABILITIES ON TLC'S PART, AND TLC NEITHER ASSUMES NOR AUTHORIZES ANY OTHER PERSON TO ASSUME FOR TLC ANY OTHER LIABILITY IN CONNECTION WITH THE SALE OF TLC'S PRODUCTS. THERE ARE NO WARRANTIES WHICH EXTEND BEYOND THE DESCRIPTION ON THE FACE HEREOF.

TEREX LIGHT CONSTRUCTION
PORTABLE LIGHT TOWER
OPERATION AND SERVICE MANUAL

This Operation and Service Manual contains information pertaining to the operation and maintenance of your Terex Light Tower. We suggest that you read this manual carefully prior to operating the tower. This manual should be retained and referred to for operation, maintenance, and ordering parts. When ordering parts, **PLEASE INCLUDE THE MODEL AND SERIAL NUMBER** located on the nameplate of the tower.

For major repair and service or other information, contact your local Terex dealer or write to:

Terex Light Construction
P.O. Box 3147
590 Huey Road
Rock Hill, SC 29730
Telephone: (803) 324-3011
FAX: (803) 366-1101

When returning parts for credit please contact the factory for Return of Goods Authorization.

Terex Model Number _____	Serial Number _____
Engine Model Number _____	Serial Number _____
Generator Model Number _____	Serial Number _____
Sold to: _____ _____	Ship to: _____ _____
Options: _____ _____	Production Date: _____
_____	Work Order Number _____
_____	Shipping Date _____
_____	In Service Date _____

When this unit left the factory the engine was filled with engine oil grade _____

IMPORTANT

WHEN REQUESTING TECHNICAL HELP AND ORDERING REPLACEMENT PARTS THE MODEL AND SERIAL NUMBER ARE NECESSARY.

REFER TO THE TEREX SERIAL NUMBER TAG ON THE UNIT FOR CORRECT MODEL NUMBER AND SERIAL NUMBER.

MODEL NUMBER IDENTIFICATION

Sample:

Light Tower Product Line	RL4	060	D	4	MH	CE
Tower Series _____						
RL4000 (RL4) = 30 Foot Basic Tower with double winch						
AL5000 (AL5) = 30 Foot Basic Tower with in-cabinet light storage and door insulation						
LT7000 (LT7) = 30 Foot Deluxe Hydraulic Tower w/optional Acoustic Enclosure and Complete Instrumentation						
kW Rating _____ (060 is 6.0 kW)						
Diesel (D) _____						
Number of Lights _____						
Type of Lights _____ HPS = High Pressure Sodium MH = Metal Halide TH = Tungsten Halogen						
European Version (AL4000 Only) _____						

RECOMMENDED ENGINE OIL & FUEL

KUBOTA D905 DIESEL ENGINE

Engine oil should be MIL-L-2104C or have properties of API classification of CD grades or higher.

Change the type of engine oil according to the ambient operating temperature:

Above 77°F (25°C)	SAE 30
32°F to 77°F (0 to 25°C)	SAE 20
Below 32°F (0°)	SAE 10W SAE 10W-30

Use #2 diesel fuel.

NOTES:

1. The temperatures in the table are the ambient temperatures at the time when the engine is started. If the running ambient temperatures are much higher than the starting temperatures, a compromise must be struck and a higher viscosity oil used. Multi-grade oils overcome the problem, provided they possess a suitable specification.
2. MIL-L-2104B or MIL-L-2104C or API CD must also be used if the sulfur content of the fuel exceeds 0.5%.
3. Always use a reputable brand of diesel fuel. The sulfur content should be below 0.5% (higher sulfur content would require more frequent oil changes). Observe strict cleanliness when filling the fuel tank.
4. Check the engine oil level before starting the engine or more than five minutes after it has been stopped. Remove the dipstick, wipe clean, reinsert it, take it out again, and check the oil level. If the oil level is too low, remove the oil filler cap and add new oil until the FULL line on the dipstick is reached.

CRITERIA FOR REPLACEMENT OF WIRE ROPE – TEREX-AMIDA LIGHT TOWERS

The wire ropes used to raise and lower the masts on a TEREX Light Tower are probably some of the most important mechanical parts used in day-to-day operation of the machinery. It is therefore very important that the cables be inspected on a frequent basis (once a month) for wear and tear, and immediately in the event of possible damage due to operator error in using the winch, or possible damage from other equipment.

NORMAL WEAR AND TEAR

When used properly, the wire ropes should give years of trouble-free service, depending on how often the masts are raised and lowered. The rule of thumb at TEREX is that if the tower is raised and lowered an average of once per day, that the cables should be replaced every two years of service.

NORMAL INSPECTION

The wire ropes are constructed of 7 strands of 19 plow steel wires each twisted together, and then the assembly galvanized to resist corrosion. Using a wadded-up cloth or heavy leather gloves (to avoid being pricked by a broken wire), run a hand up and down a length of the cable. If any exterior wires are broken, they will lift up from main body of the cable and become visible. For any given 1 foot of cable length; if there are 4 or more wires each, on any 2 or more strands broken, the suspect rope should be replaced immediately.

OPERATOR ERROR – OTHER MACHINERY DAMAGE

One of the most common reasons for failure of a Light Tower wire rope is due to operator error in using the winch, or damage to the cable by tools or other machinery. The most common operator error happens when the mast is telescoping down. When the upper telescoping lock engages, the operator does not pull the lower pivot lock out (located on the tower base) and keeps on cranking the winch. This results in the cable becoming loose around the drum due to the tower not pivoting down. This can result in three problems: the loose cable can get trapped underneath itself, resulting in a sudden or partial “drop” of the mast when the loose section releases at a later time, thus damaging the cable; or the cable can jump off the winch drum and be damaged by the gears of the winch. The loose cable can also cause the drum to spin to take up the slack cable. If there is enough friction in the threaded parts of the winch, the drum can cause the crank handle to start spinning. This can cause the tower to “freefall” and the results can be catastrophic for anyone standing underneath the tower. A spinning crank handle can also break bones. Other reasons damage can occur are due to some outside force such as forklift blade nicking or crushing a cable when moving a unit, or an accidental blow or damage by a hand tool, etc.

DAMAGE INSPECTION

If any nicks (partial strand cut through), kinks (permanent bends), or weld spatter on the cable (from field service) are observed, the suspect wire rope should be changed immediately. If there is a crushed spot somewhere on the wire rope, it should be replaced only if the width of the crushed spot exceeds 1-1/4 times the nominal diameter of the cable (5/16” on a 1/4” cable, and 7/32” on a 3/16” cable), or if there are broken wires at the point of damage.

RL4000 CABLE ROUTING INSTRUCTIONS

These instructions deal with the assembly and routing of cable for the Terex RL4000 boom, and should aid in making this a smooth assembly. Each boom consists of three separate stages: referred to here as the tower (1), the second stage (2), and the upper (3) boom tubes (see Figure 1).

ASSEMBLY

1. Feed cable up through the hole on the bottom of the second stage boom tube with the crimped end at the bottom and lay the cable along the length of the tube as shown here.
2. Slide the second stage boom tube into the tower boom tube.
3. Run the cable over the upper pulley on the tower boom tube as shown here and in Figure 2.

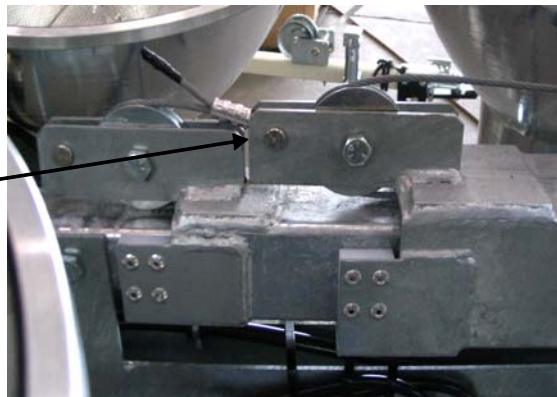

Clevis Pin

Figure 2. Cable Routed Through Pulley

3. Attach opposite end of cable to the winch on the tower boom tube (See Figure 3).
4. Repeat Steps 1 – 3 for the upper boom tube, and attach cable to the clevis pin on the second stage boom tube shown in Figure 2.

Figure 3. Winch

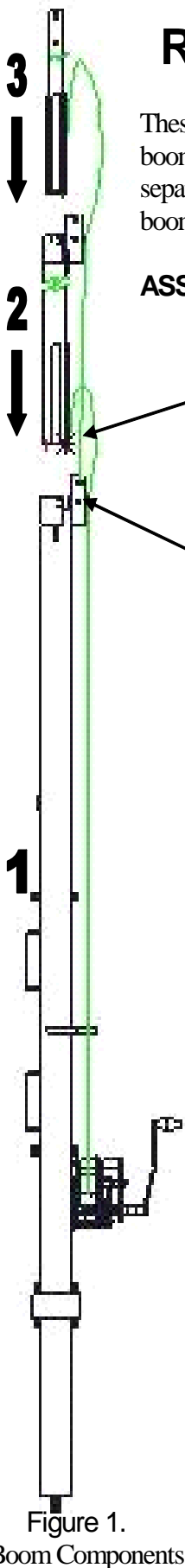

Figure 1.

Boom Components

GENERAL INFORMATION-PARTS MANUAL

INTRODUCTION

This manual contains parts ordering information for the Terex RL 4000 light tower.

IDENTIFICATION of PARTS

All parts are identified with a part number and brief description. If there are multiple quantities of the part required, the quantity required will be shown along with part number and description. If no quantity is given it is assumed that there is only one part required.

NOTES and DESIGNATIONS

This manual is compiled from information available and current at time of approval for printing. Terex reserves the right to improve its product without notice to follow its policy of constantly striving to manufacture a better product.

ILLUSTRATIONS

The illustrations in this manual are intended to show typical construction of the various parts. In some instances the shapes or details of the parts illustrated may not exactly represent their actual appearance. However, they will serve to show the servicing methods explained or help to identify parts performing the same function.

PARTS ORDERING INFORMATION

IMPORTANT

When a part fails and needs to be replaced, only use equivalent parts of equal performance and strength.

Contact your local Terex dealer for parts and service.

When ordering parts for a specific unit, follow the instructions listed below. By doing so, you will be assured of receiving the correct part in the shortest period of time.

1. Send your order to the nearest Terex distributor in your area.
2. Give the light tower model and serial number.
3. Write the quantity required, part number, and description of the parts wanted.
4. Give the specific shipping instructions, to whom and where parts are to be shipped, also whether shipment is to go parcel post, express freight, or truck, prepaid or collect. We want your order to reach you as quickly and as economically as possible.
5. Confirm all telephone orders in writing via main or fax confirmation.

PART NUMBERS AND PRICES ARE SUBJECT TO CHANGE WITHOUT NOTICE.



TEREX
LIGHT CONSTRUCTION

Model: RL4000 Light Tower
Title: Cabinet Decal Layout

TOP PANEL

109055
DECAL KIT

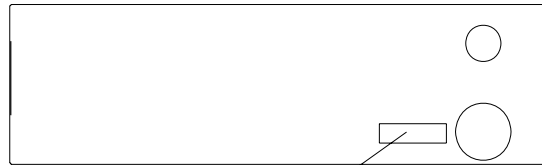

850150

FRONT PANEL

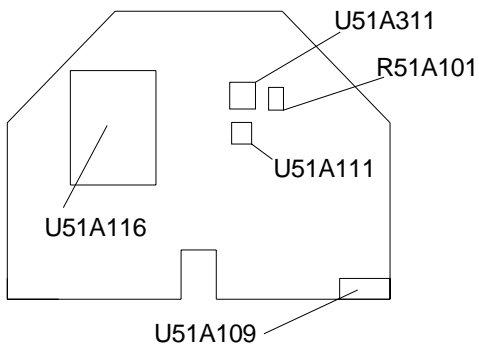

REAR PANEL

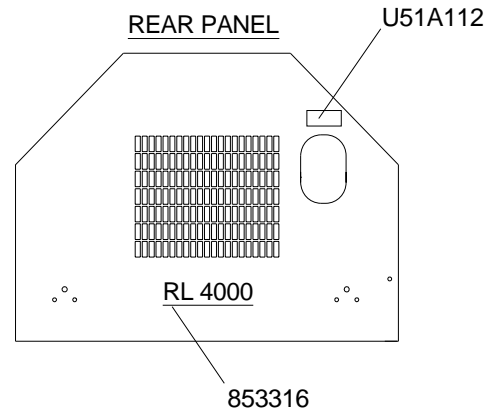

LEFT ACCESS DOOR

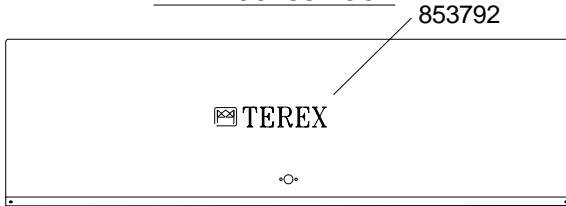

853736 AND 853737 INSIDE DOOR

RIGHT ACCESS DOOR

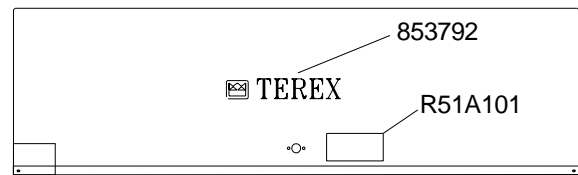

52100100 U51A102 INSIDE DOOR

LEFT UNDERDOOR PANEL

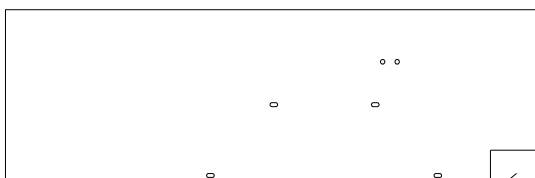

U51A105

RIGHT UNDERDOOR PANEL

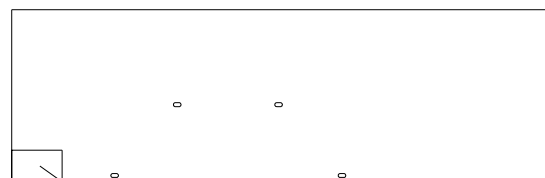

U51A105



TEREX
LIGHT CONSTRUCTION

Model:

RL4000 Light Tower

Title:

Frame Assembly

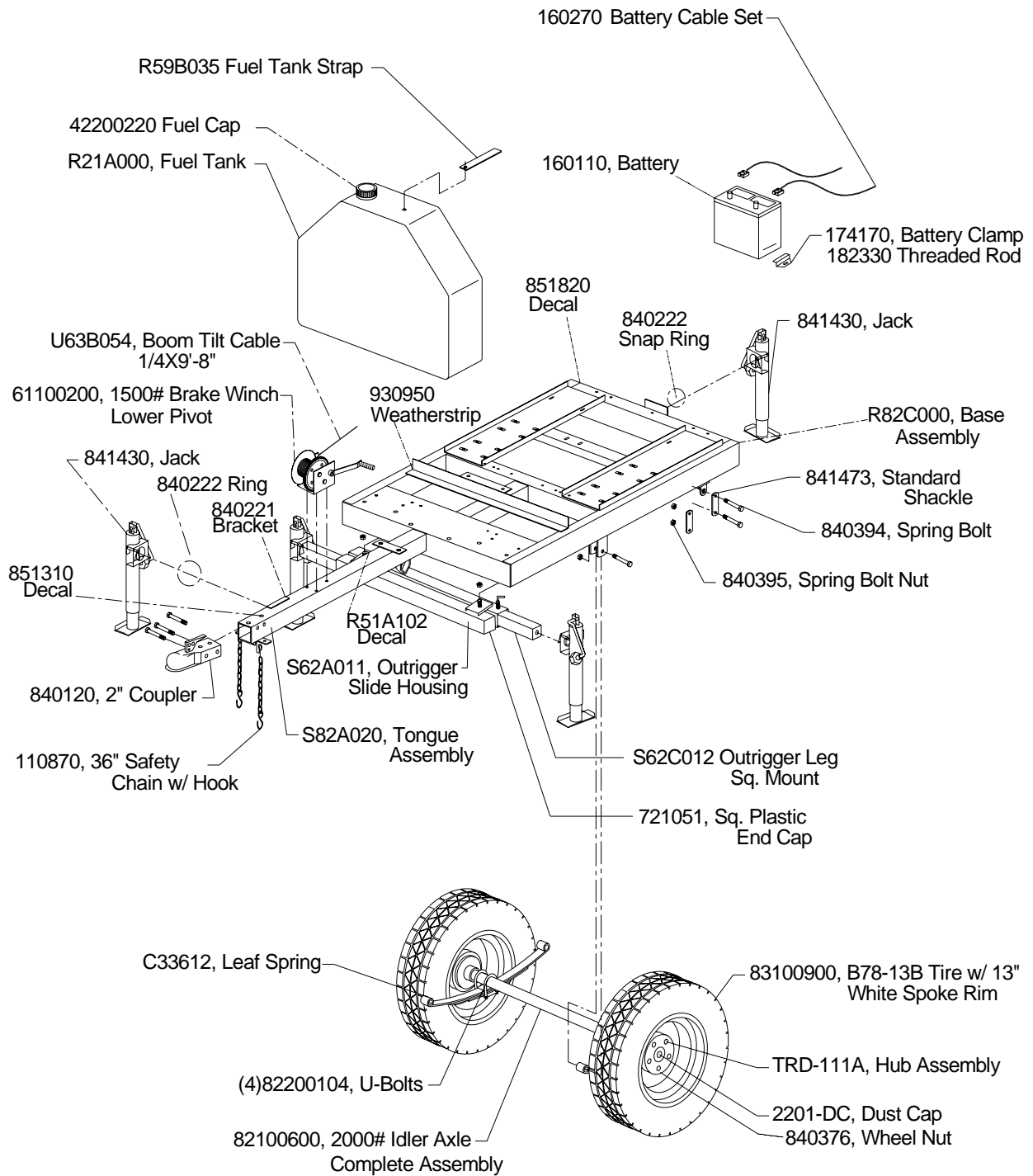



TEREX
LIGHT CONSTRUCTION

Model:	RL4000 Light Tower
Title:	Cabinet Assembly

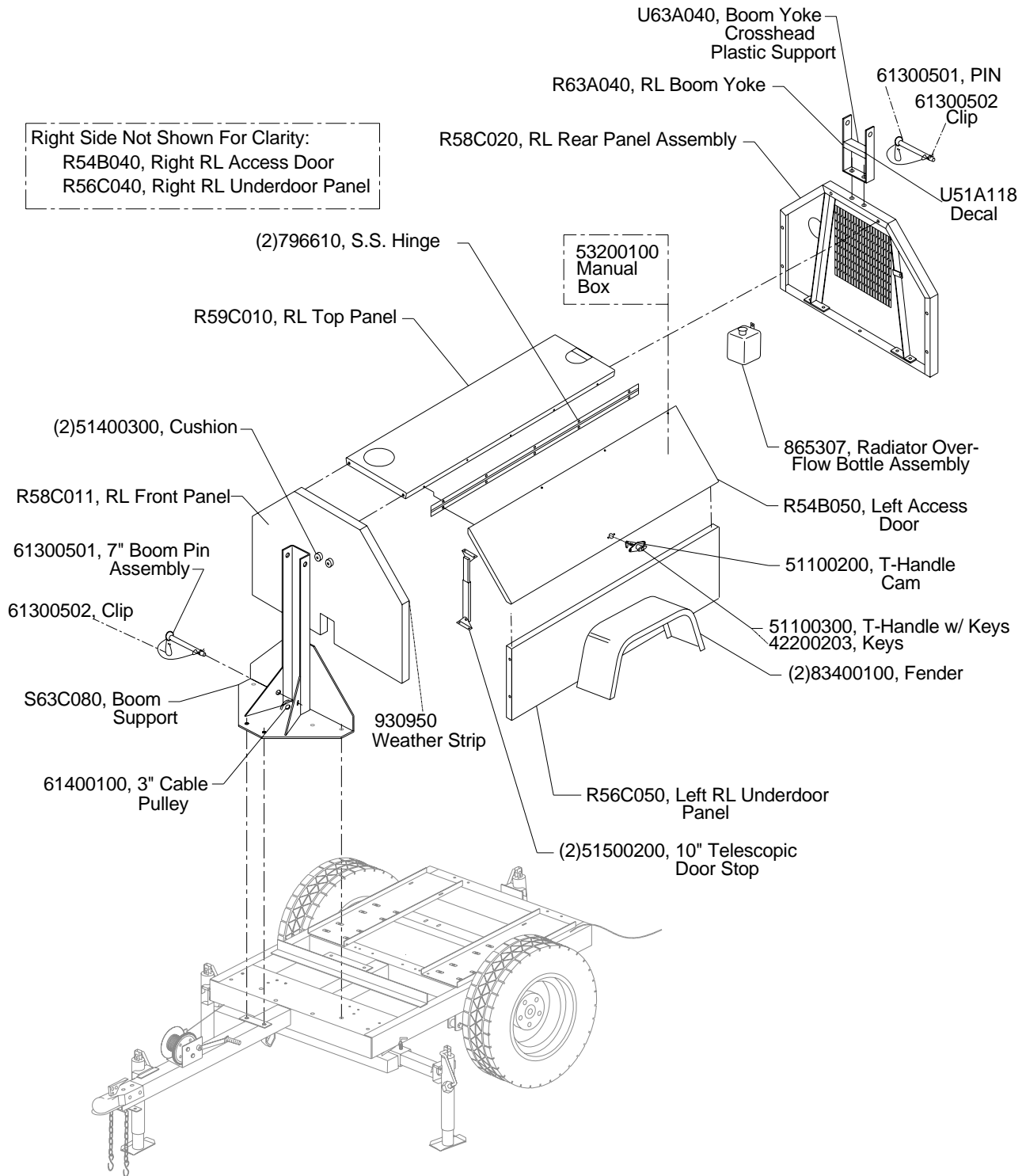



TEREX
LIGHT CONSTRUCTION

Model:

RL4000 Light Tower

Title:

Tower Assembly

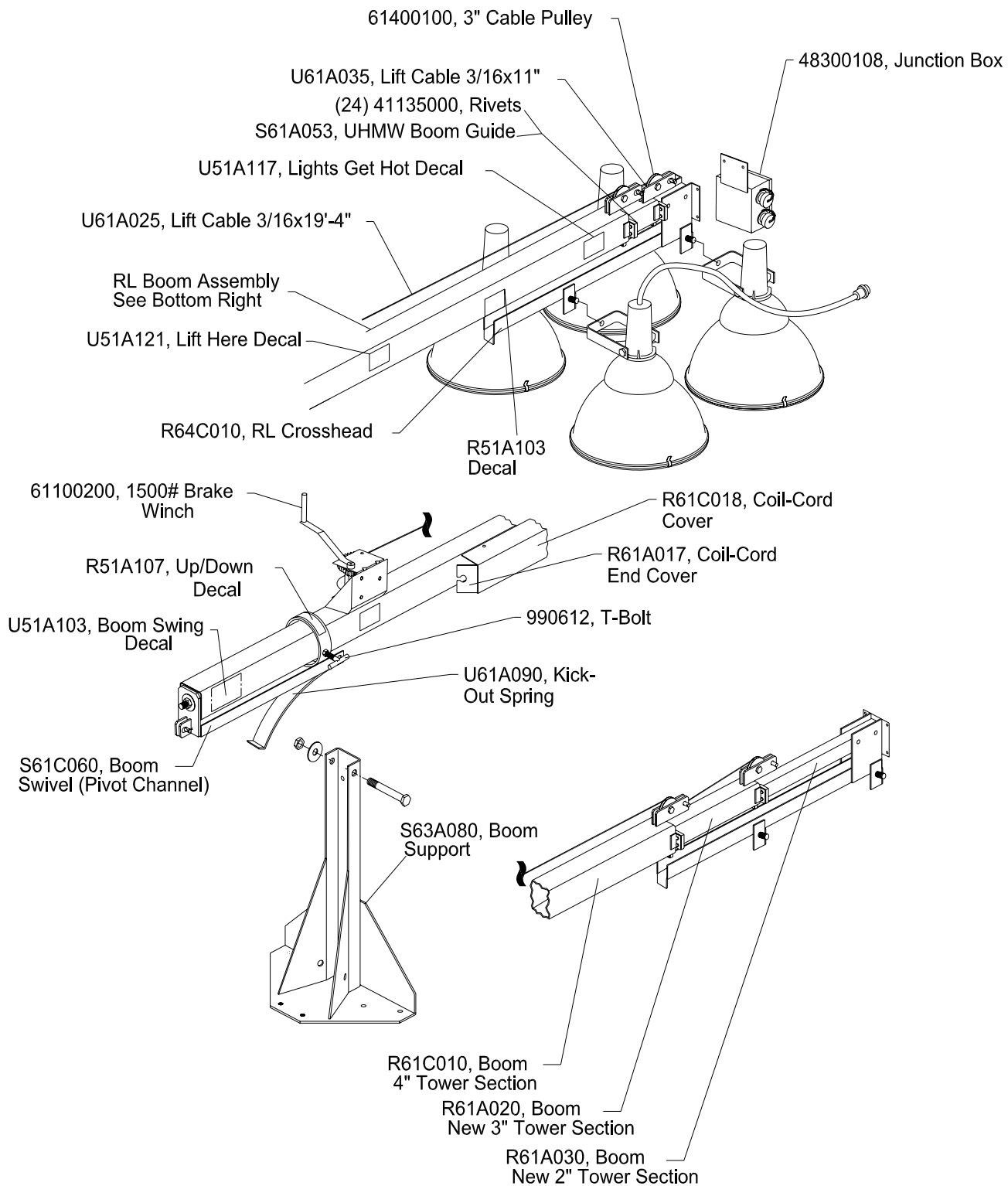



TEREX
LIGHT CONSTRUCTION

Model: RL4000 LIGHT TOWER

Title: Electrical Control Box

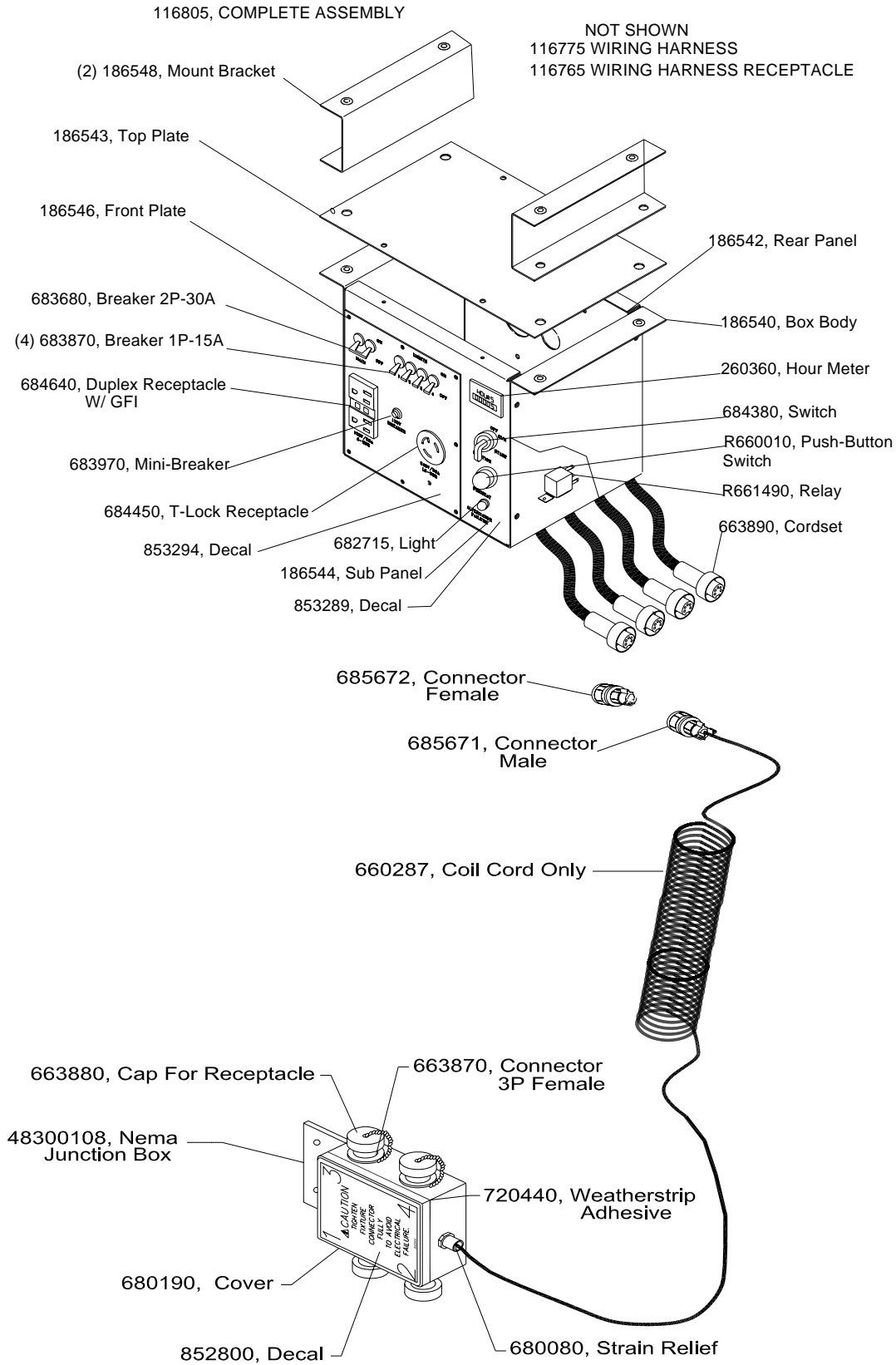



TEREX
LIGHT CONSTRUCTION

Model: RL4000 Light Tower

Title: Ballast Assembly

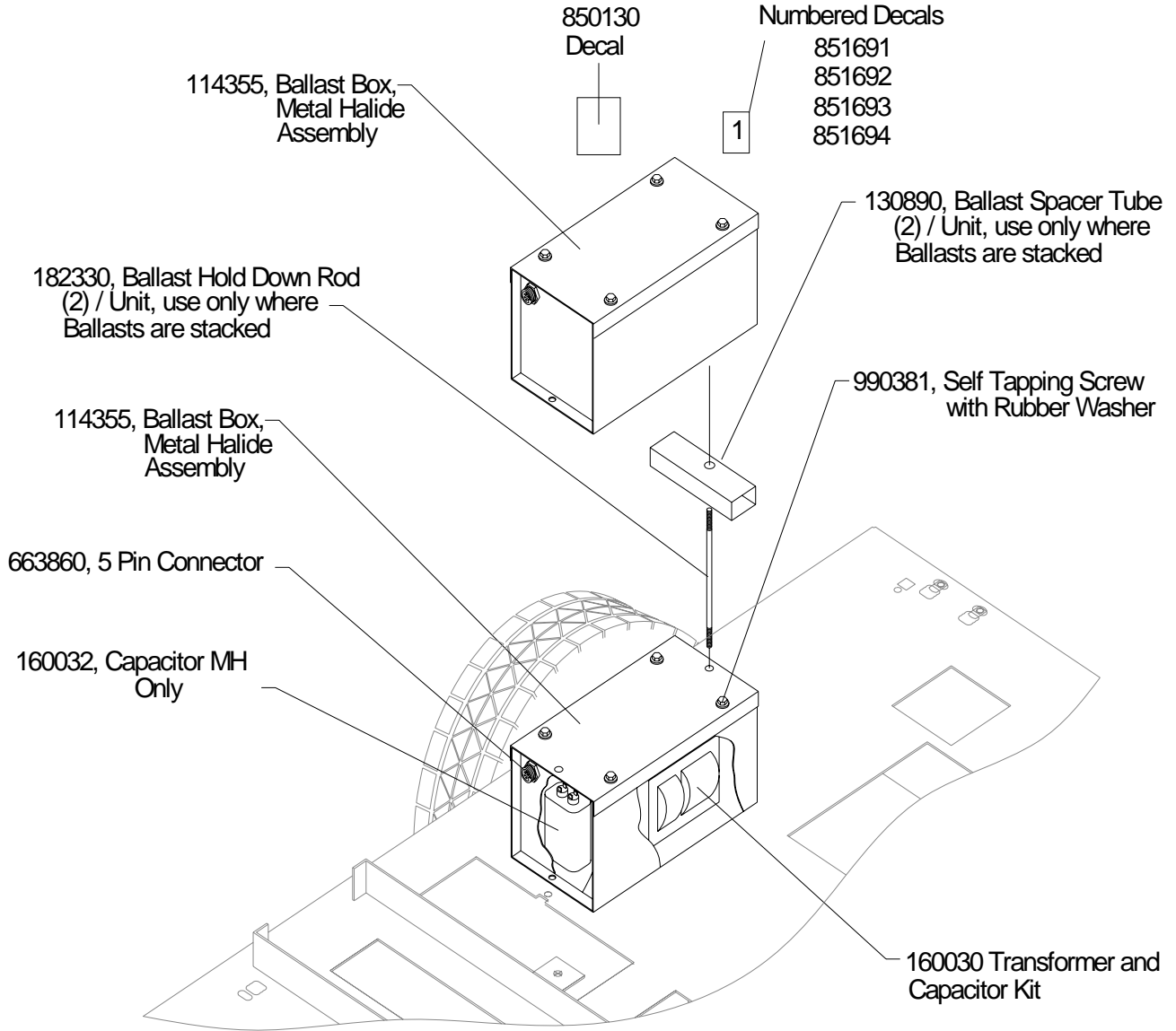



TEREX
LIGHT CONSTRUCTION

Model:

RL4000 Light Tower

Title:

Fixture Assembly

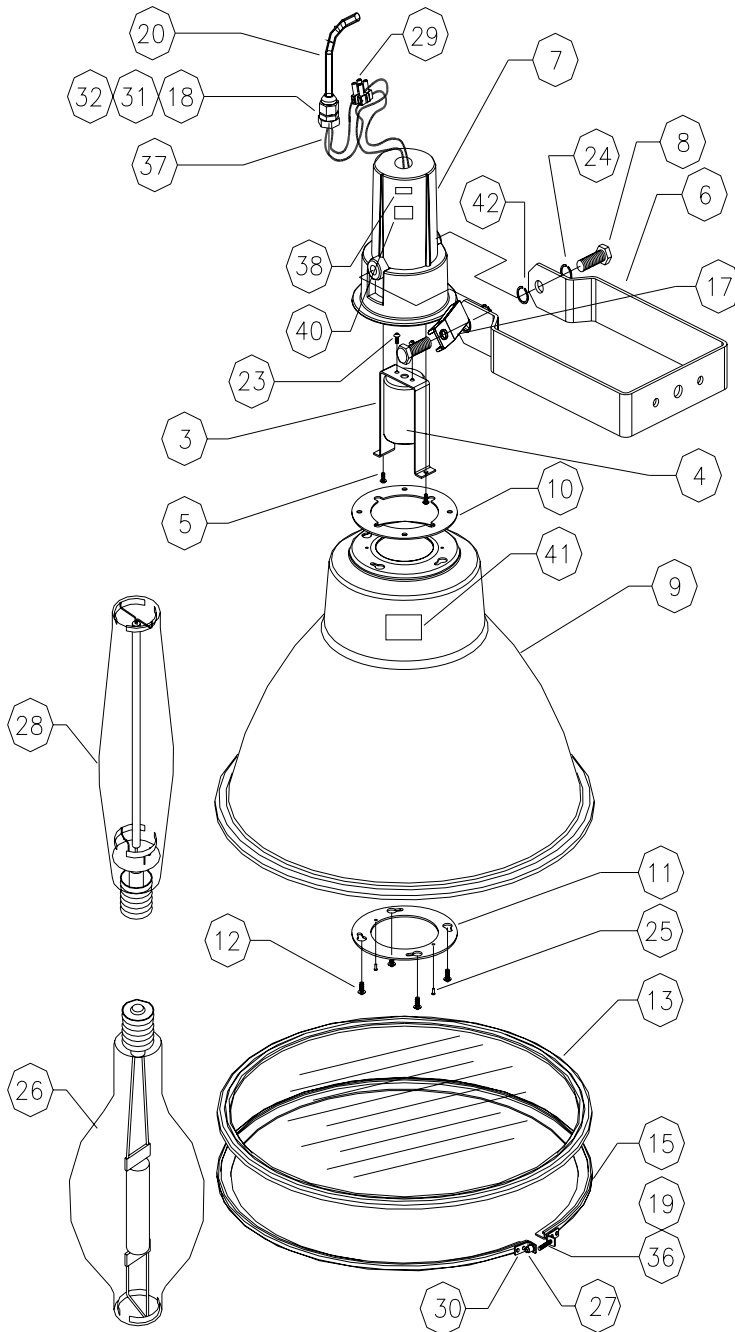

NOTE: FOR COMPLETE MH ASSEMBLY
ORDER PART# C41100720

TEREX PART#	#	DESCRIPTION	QTY.
833563	3	SOCKET BRACKET (T&B 057-05-80643)	1
833564	4	SOCKET MOGUL BASE W/ WIRES	1
833565	5	SCREW 8-32 x 3/8" PH PH TT ZC	2
833566	6	TRUNNION FOR GENERATOR	1
833567	7	HOUSING ALUM. CST. FOR GENERATOR	1
990810	8	BOLT 1/2-13 x 1-1/2" HH MS SS	2
833568	9	REFLECTOR 18" ALUM. PEENED	1
833569	10	GASKET HIF (T&B - B61178)	1
833570	11	REINFORCING RING (T&B - B60198)	1
833571	12	SCREW 10-24 x 5/8 HW SL TT	4
833524	13	VULCANIZED GASKET SILICONE - 1/8" LENS COMBINATION	1
833543	15	CLAMP BAND Ø19.5" ALUMINUM	1
833573	17	HANDLE FOR 1/2-13 BOLT (DWG) (OPTIONAL)	1
682470	18	STRAIN RELIEF #2521 T&B	1
833574	19	SCREW 8-32 X 1 HH SL MS SS	1
663850	20	CORD #16-3 SLOW 105°C + 2 TERM. RING	1
833577	23	SCREW 8-32 x 5/8" FH PH MS ZC	2
991650	24	SPLIT WASHER 1/2 SS	2
990675	25	RIVETS Ø1/8" ALUM. 3/16" LENGHT	2
160071	26	LAMP, 1000 WATT METAL HALIDE	1
833578	27	NUTSERT 8-32 X Ø1/4" X 13/32" LENGHT	1
160140	28	LAMP, 1000 WATT HP SODIUM (OPT.)	1
709034	29	EURO CONNECTOR TERMINAL STRIP	2
683950	31	SEAL RING .755" ID - EPDM	1
680020	32	LOCKNUT 1/2	1
833581	36	FIBER WASHER	1
833582	37	FIBERGLASS SLEEVE 2-1/2"	.5
833583	38	LBL WET LOCATION/EXTERIEUR	1
	39		
833584	40	LBL 105C SUPPLY COND.	1
833585	41	LBL FIXTURE CSA - NRTL/C	1
995970	42	WASHER 1/2 EXTER. TOOTH LOCK SS	2



TEREX
LIGHT CONSTRUCTION

Model:	RL4000 LIGHT TOWER
Title:	Genset, Kub-D905/L-S 6KW

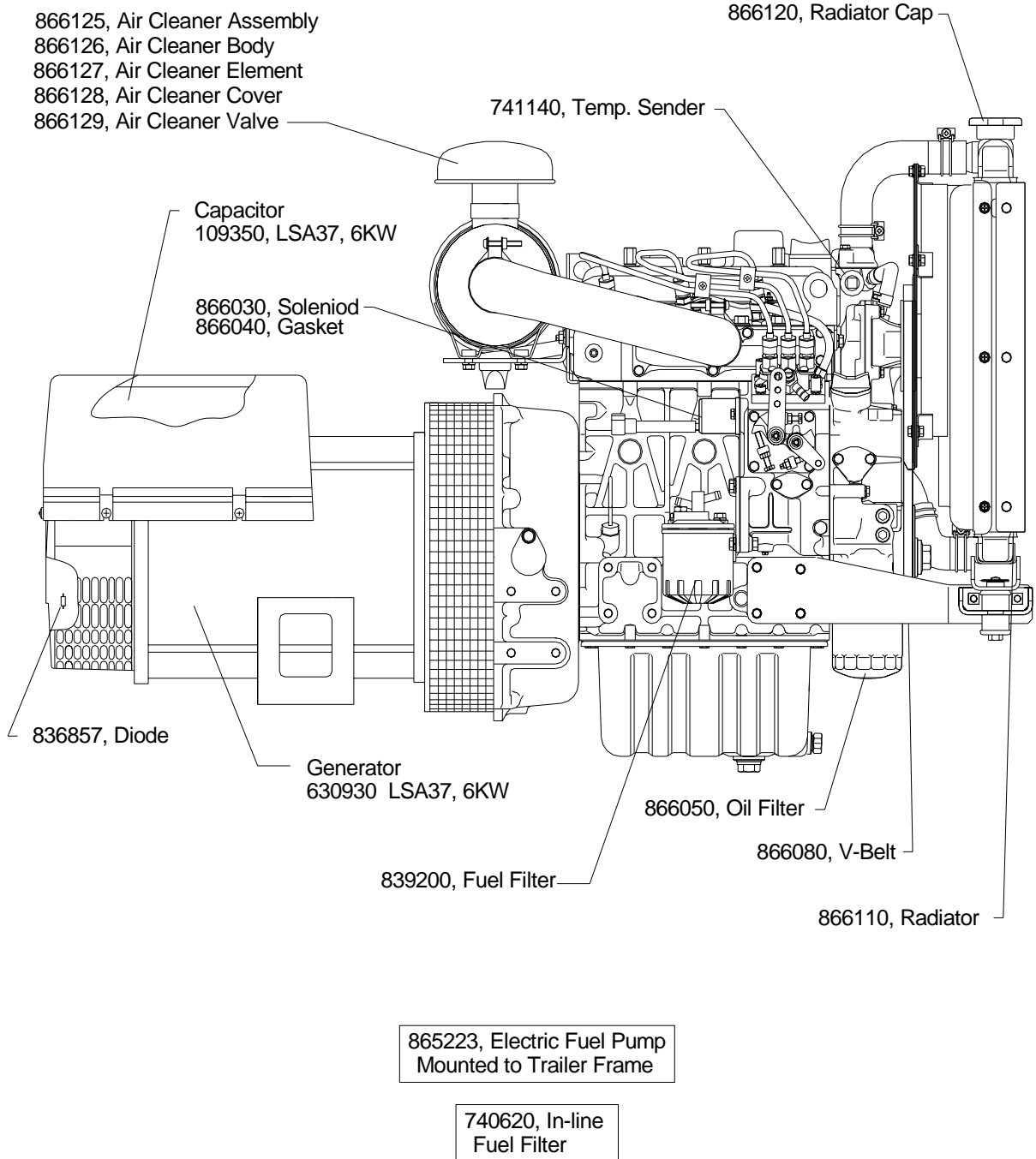



TEREX
LIGHT CONSTRUCTION

Model:

RL4000 Light Tower

Title:

Genset, Kub-D905/L-S 6KW

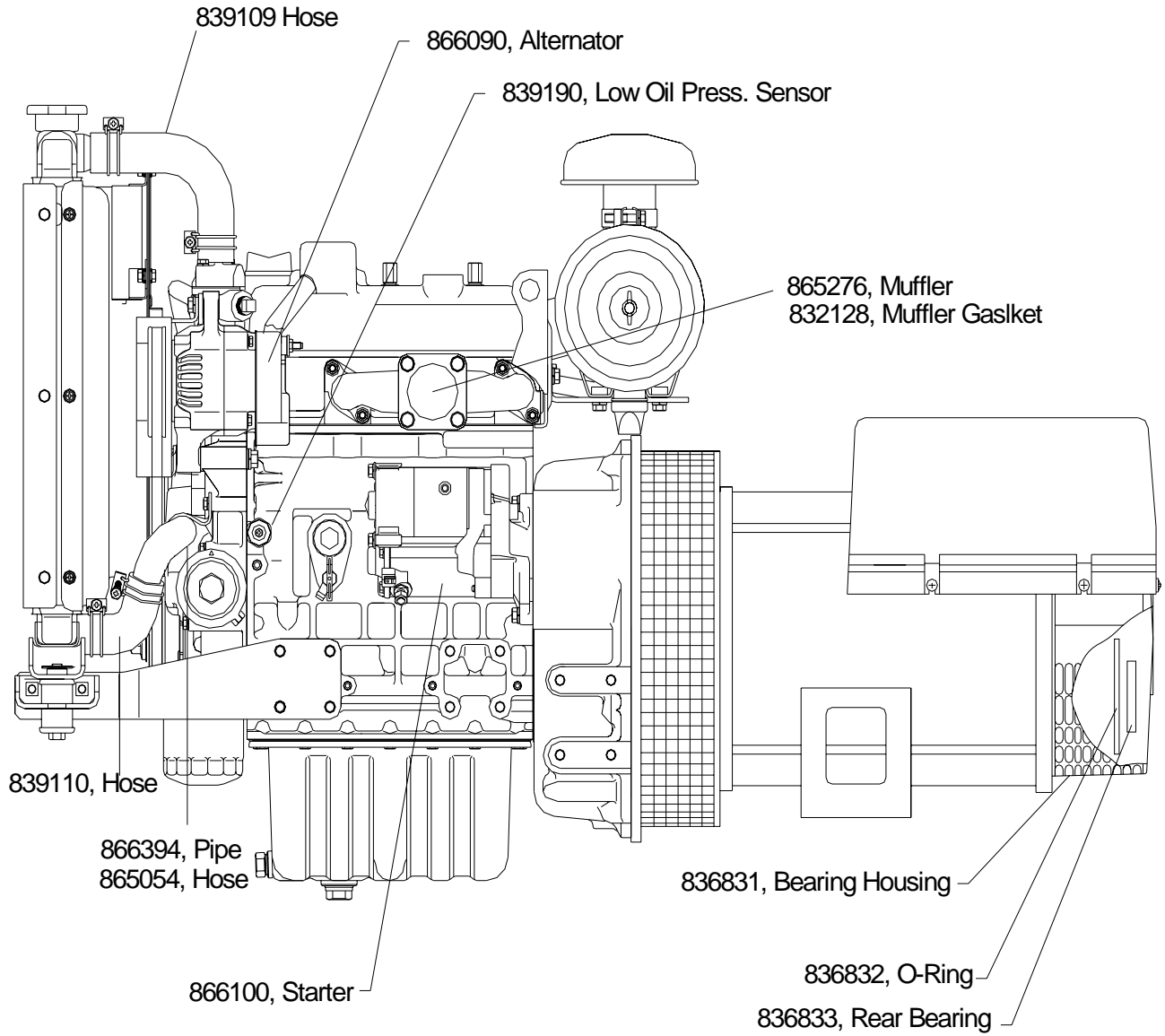



TEREX
LIGHT CONSTRUCTION

Model: RL4000 Light Tower

Title: Radiator

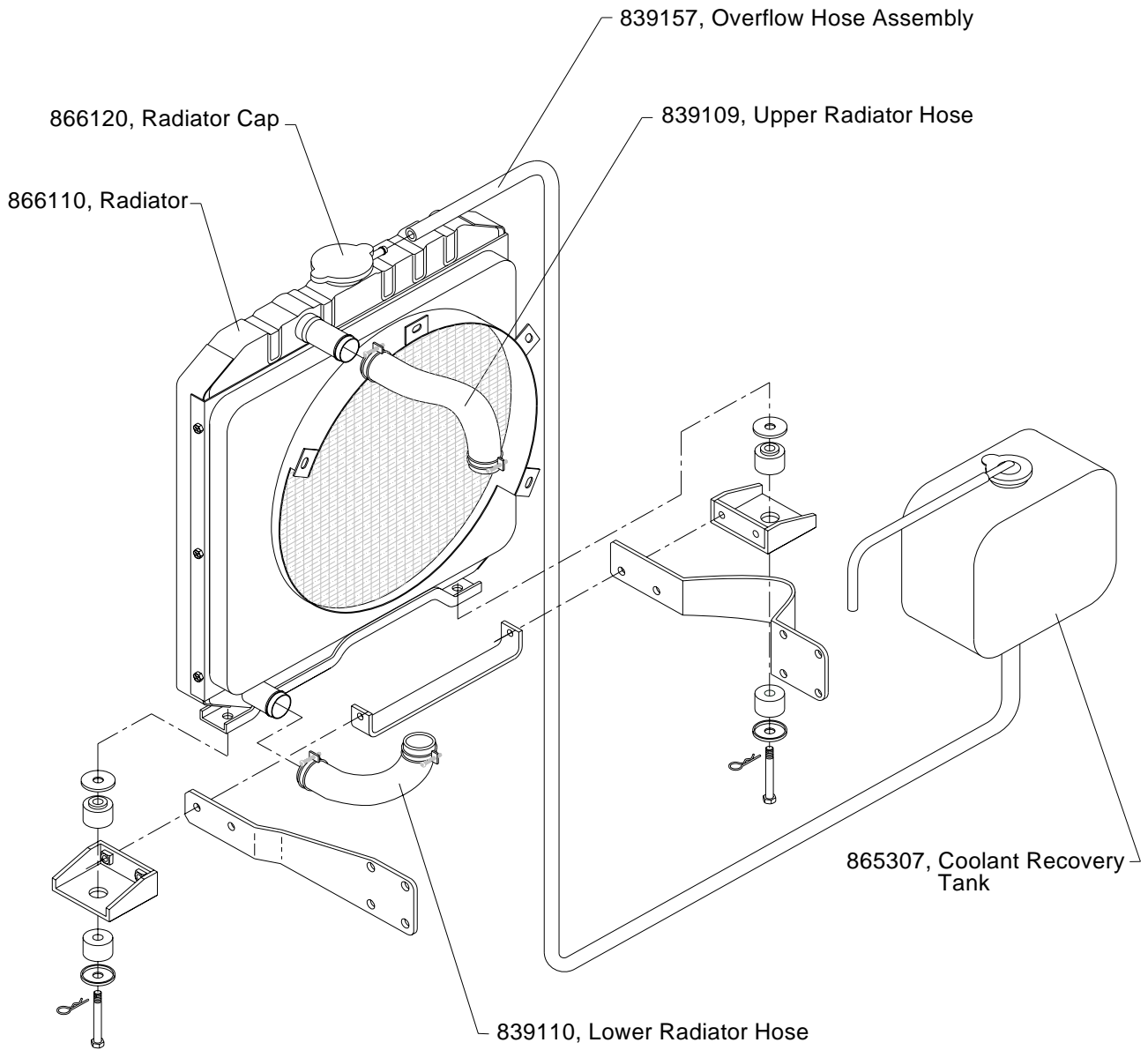



TEREX
LIGHT CONSTRUCTION

Model:	RL4000 Light Tower
Title:	Generator

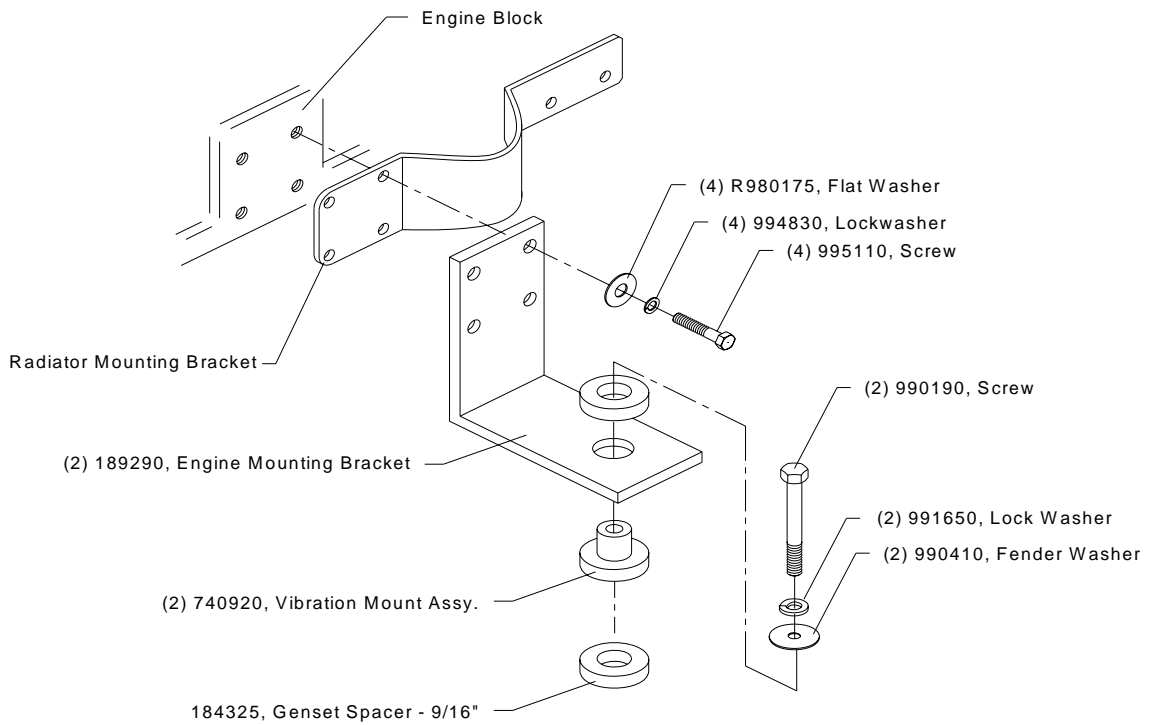
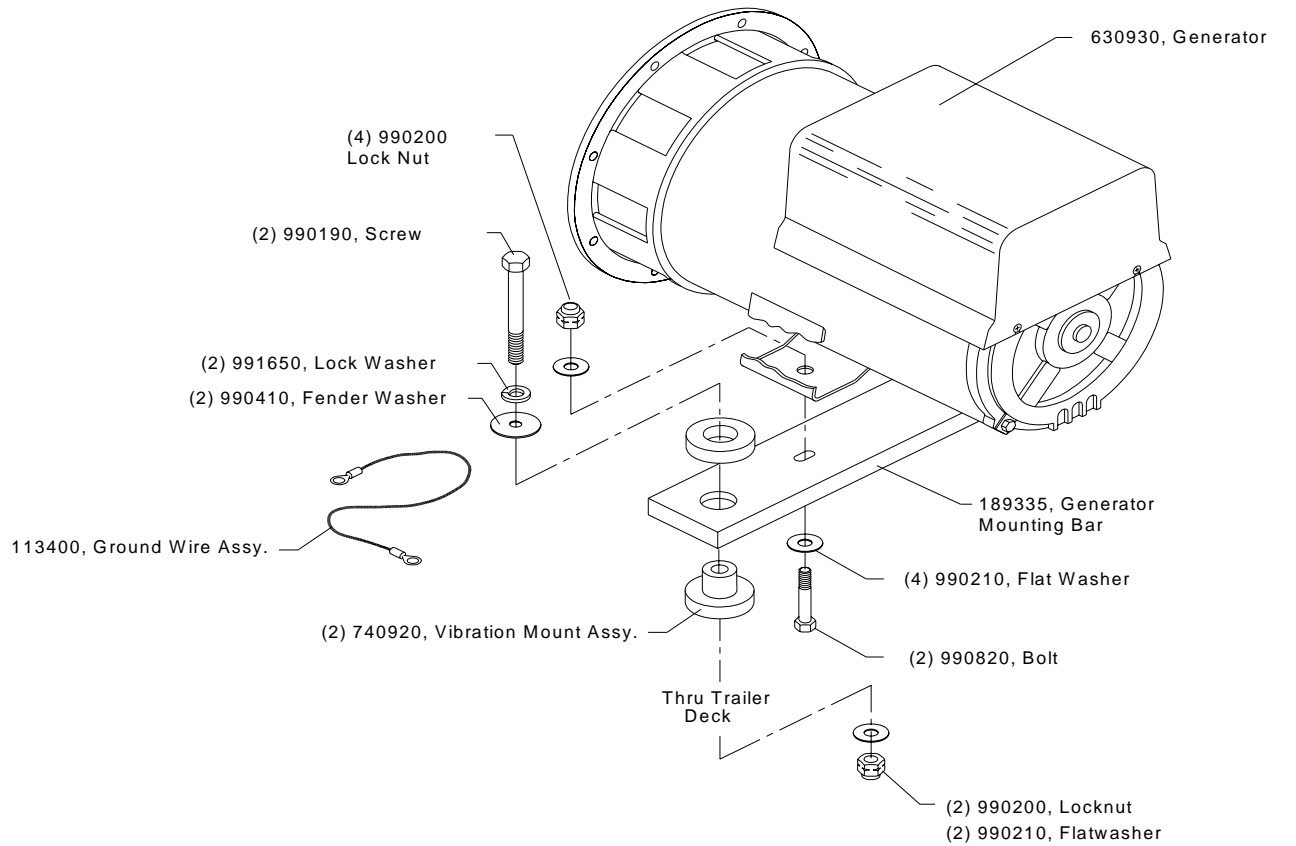



TEREX
LIGHT CONSTRUCTION

Model: RL4000 LIGHT TOWER

Title: Trailer Hitches

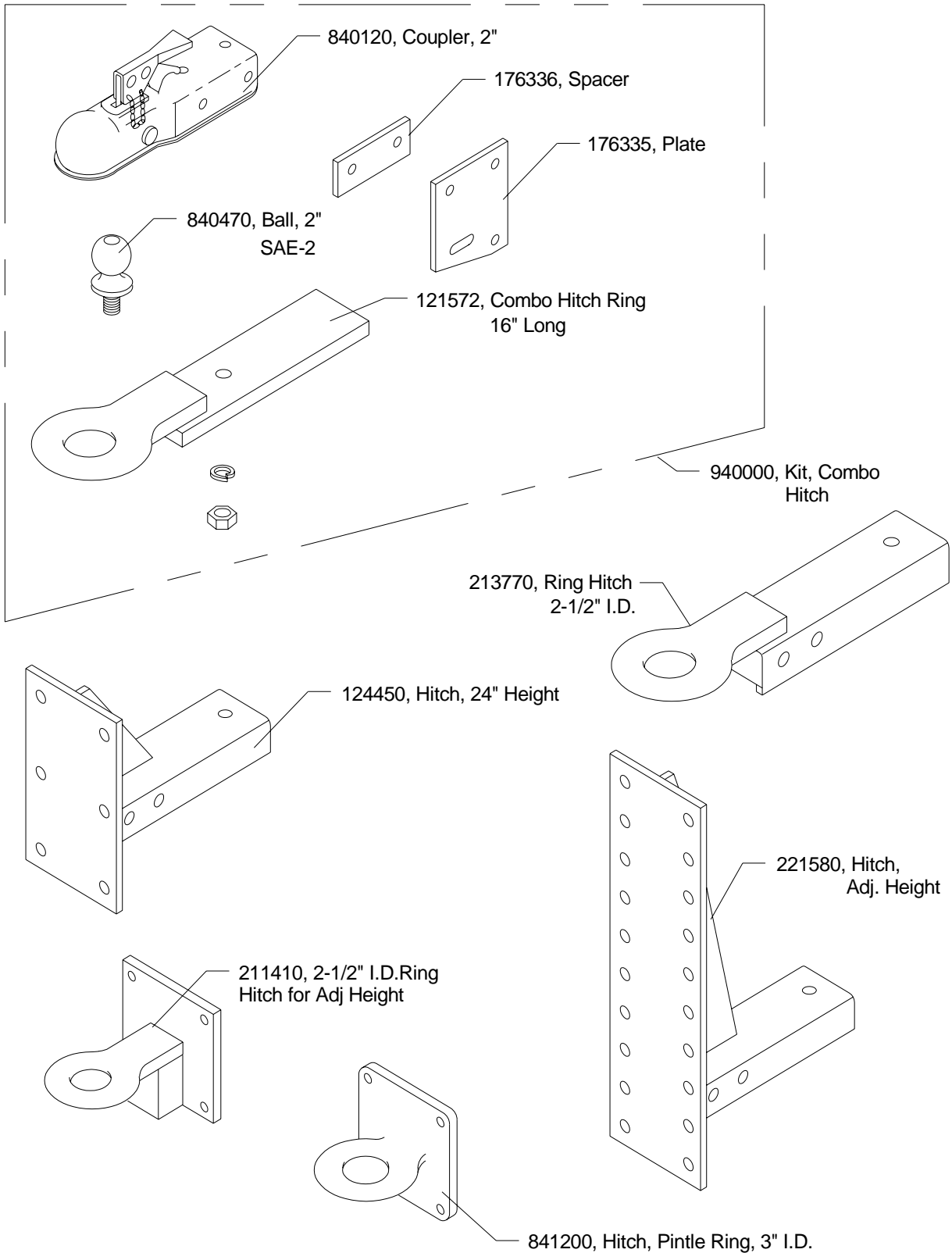





TEREX
LIGHT CONSTRUCTION

Model: RL4000 LIGHT TOWER

Title: TRAILER LIGHTS

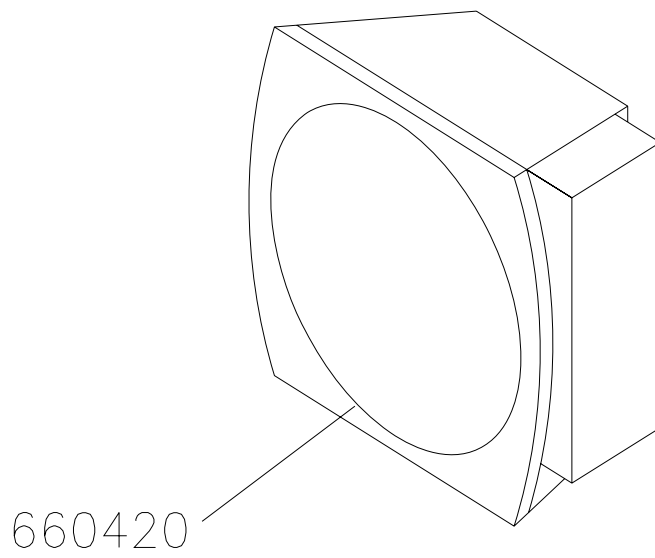
Option:
OLTX0083



 TEREX LIGHT CONSTRUCTION	Model: RL4000 LIGHT TOWER	Option: 0LTX0271
	Title: DOME LIGHT	

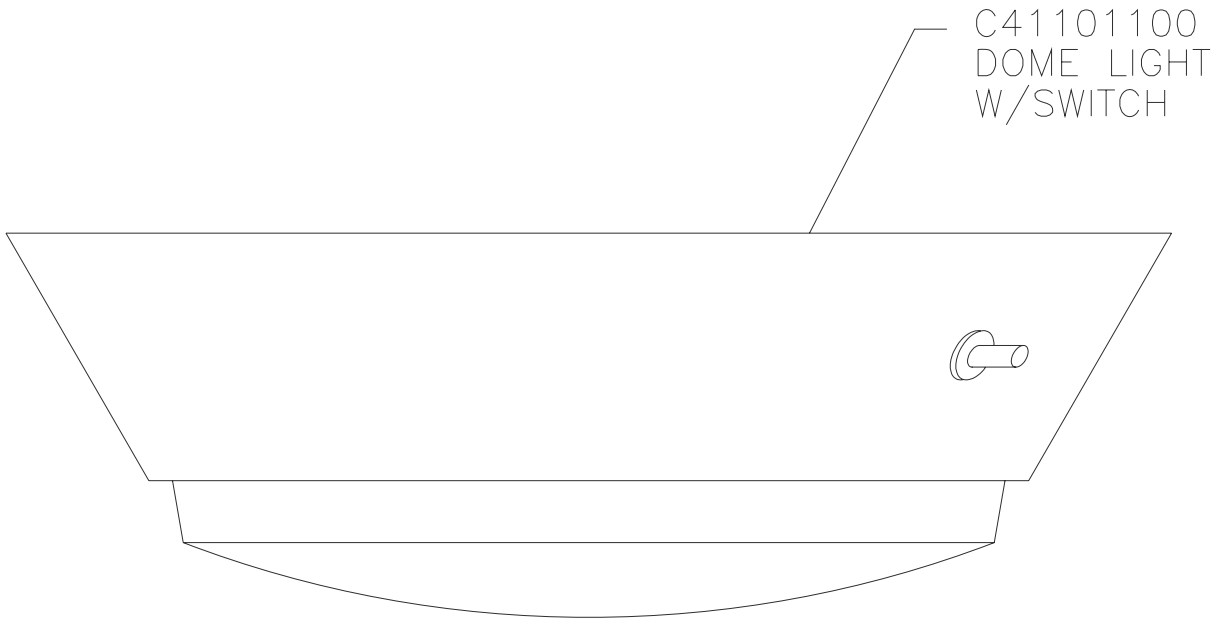



TEREX
LIGHT CONSTRUCTION

Model:

RL4000 LIGHT TOWER

Option:

OLTX0265

Title:

SPARE TIRE AND WHEEL

R82A150
MOUNT BRK'T

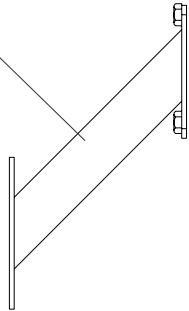

R82A160
MOUNT CLAMP

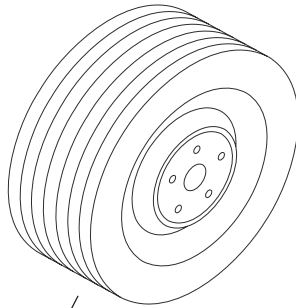
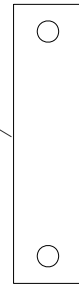

C83100900
TIRE & WHEEL MOUNTED B78-13B, WITH 13" BLACK RIM



TEREX
LIGHT CONSTRUCTION

Model: RL4000 LIGHT TOWER

Title: EXTRA GFI DUPLEX RECEPTACLE

Option:
0LTX0210

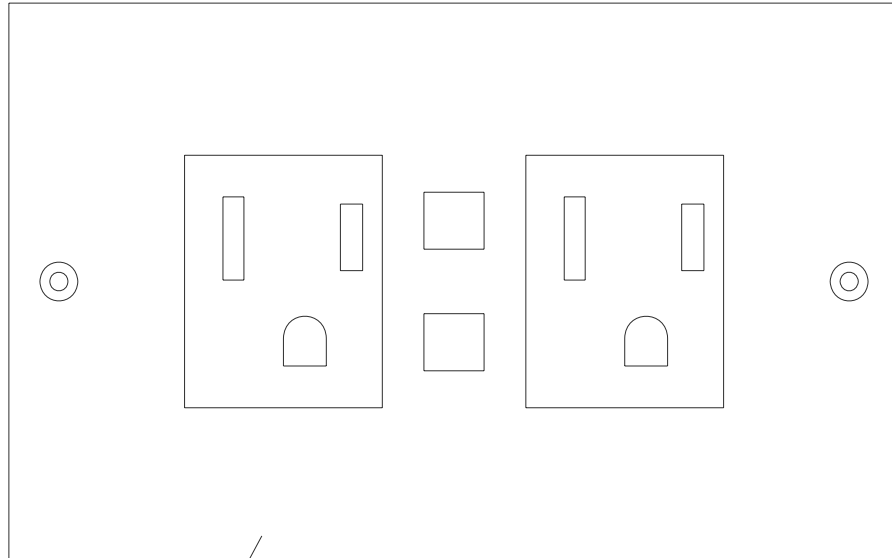

684640
RECEPTACLE, 20A, 120V DUPLEX W/ GFI

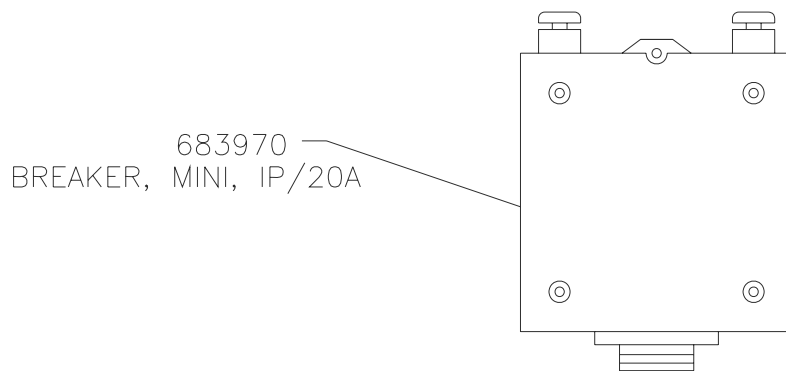

683970
BREAKER, MINI, IP/20A

 TEREX LIGHT CONSTRUCTION	Model: RL4000 LIGHT TOWER	Option: OLTY0319
	Title: ELECTRIC TRAILER BRAKES	

842084 COMPLETE
AXLE ASSEMBLY

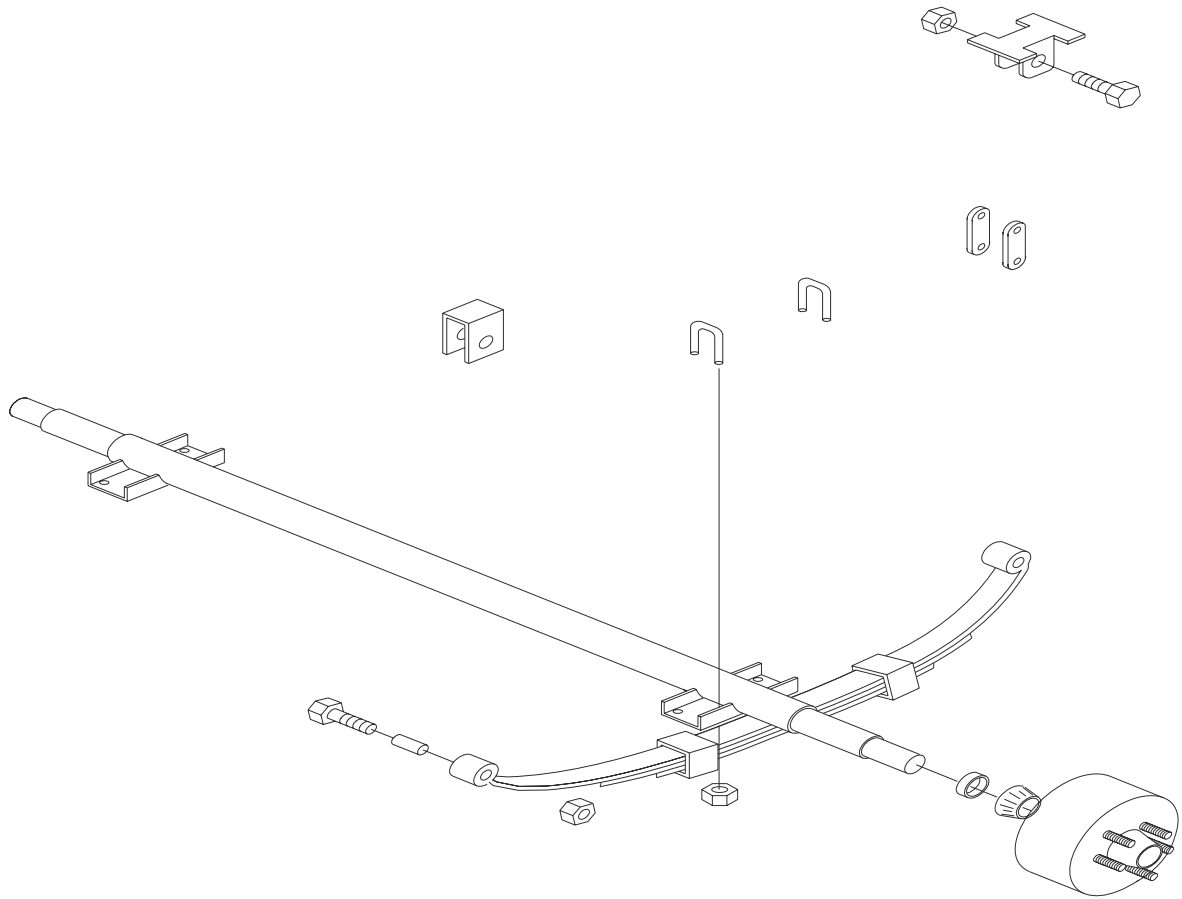



TEREX
LIGHT CONSTRUCTION

Model: RL4000 LIGHT TOWER

Title: BATTERY BLANKET

Option:
OLTX0130

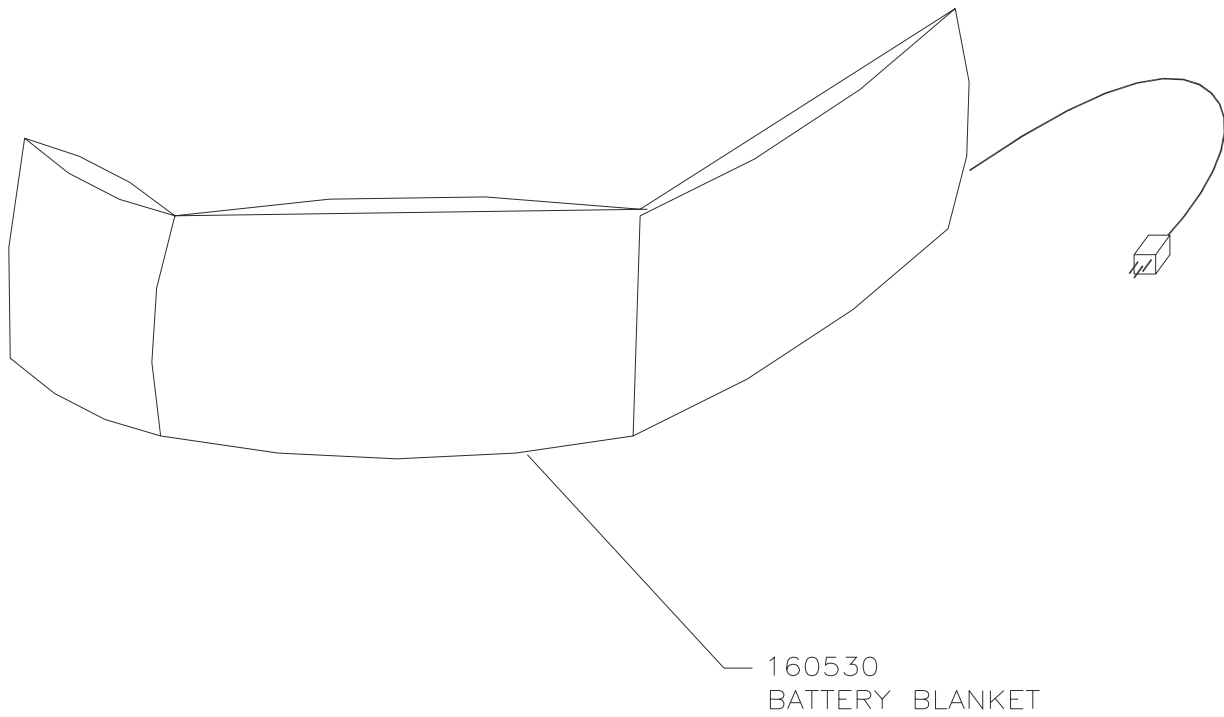

160530
BATTERY BLANKET



TEREX
LIGHT CONSTRUCTION

Model: RL4000 LIGHT TOWER

Title: BATTERY 700 AMP

Option:
0LTX0222

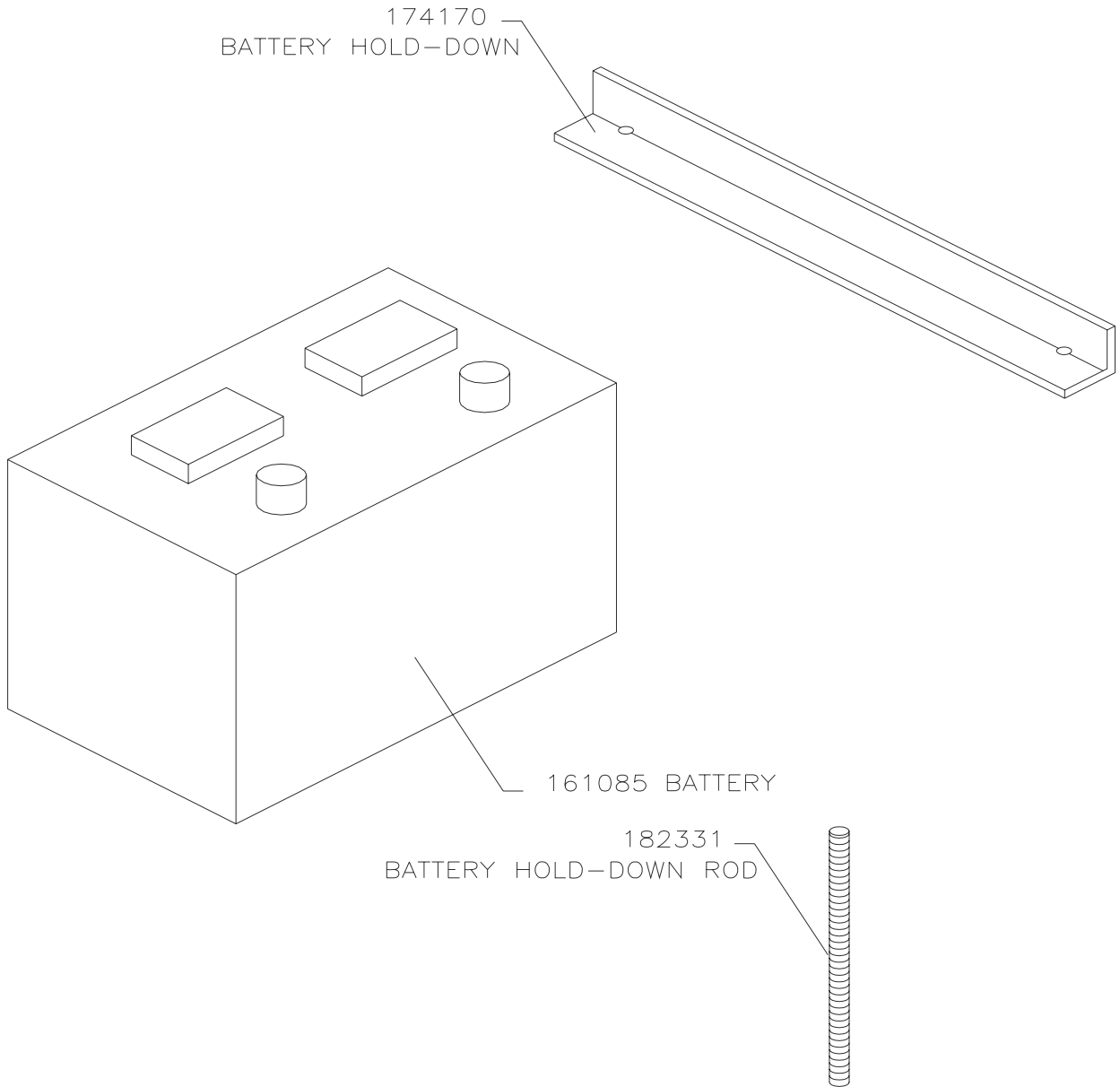



TEREX
LIGHT CONSTRUCTION

Model: RL4000 LIGHT TOWER

Title: FUEL LINE HEATER

Option:
OLTX0140

