



# COMMUNICATIONS SERVICE MONITOR 2944B



## Operating Manual

Document part no. 46892/744

Issue 1

20 March 2006

---

# COMMUNICATIONS SERVICE MONITOR 2944B

© Aeroflex International Ltd. 2006

*No part of this document may be reproduced or transmitted in any form or by any means, electronic or mechanical, including photocopying, or recorded by any information storage or retrieval system, without permission in writing by Aeroflex International Ltd. (hereafter referred to throughout the document as 'Aeroflex').*

Printed in the UK

Document part no. 46892/744 (PDF version)  
Based on Issue 1 of the printed manual.

20 March 2006

---

# About this manual

This manual explains how to use the Communications Service Monitor 2944B. It applies to instruments fitted with main software version 5.xx or later and cellular software version 5.xx.

## Intended audience

People who need to test mobile radio systems and associated equipment.

## Structure

### Chapter 1

General information and performance specification.

### Chapter 2

Gives installation instructions, including connection of peripheral equipment.

### Chapter 3

Operating instructions. Setting up and use.

### Chapter 4

Brief technical description.

### Chapter 5

Acceptance testing procedure for the Service Monitor.

## Document conventions

The following conventions apply throughout this manual:-

[Tx TEST]	Hard key titles are shown verbatim, using normal lettering in square brackets.
<i>[Tx freq]</i>	Soft key titles are shown verbatim using italic lettering in square brackets.
RF IN/OUT	Titles on the instrument panels are shown verbatim using capital letters.
	Text displayed on screen. See below <sup>†</sup>

<sup>†</sup> References to text displayed on the screen of the Service Monitor are given verbatim, using a font that resembles the displayed text. e.g. GEN FREQ: , Ref Level: , **Ref Level:**

## Associated publications

Other manuals that cover specific aspects of this service monitor are:-

- Programming Manual 46882/683 provides programming information for remote control of the Service Monitor using MI-BASIC and GPIB.
- Service Manual 46880/118, (comprising Operating Manual 46882/744 and Maintenance Manual 46882/745) provides servicing information for the Communications Service Monitor 2944B.

---

# Contents

<b>PRECAUTIONS .....</b>	<b>v</b>
<b>Chapter 1 GENERAL INFORMATION .....</b>	<b>1-1</b>
<b>Chapter 2 INSTALLATION.....</b>	<b>2-1</b>
<b>Chapter 3 LOCAL OPERATION .....</b>	<b>3-1</b>
<b>Chapter 4 TECHNICAL DESCRIPTION .....</b>	<b>4-1</b>
<b>Chapter 5 ACCEPTANCE TESTING.....</b>	<b>5-1</b>
<b>INDEX .....</b>	<b>Index-1</b>

---

# Precautions

**WARNING**

**CAUTION**

**Note**

These terms have specific meanings in this manual:

**WARNING**

information to prevent personal injury.

**CAUTION**





information to prevent damage to the equipment.

**Note**

important general information.

## Hazard symbols

The meaning of hazard symbols appearing on the equipment and in the documentation is as follows:

Symbol	Description
	Refer to the operating manual when this symbol is marked on the instrument. Familiarize yourself with the nature of the hazard and the actions that may have to be taken.
	Dangerous voltage
	Toxic hazard
	Hot surface

## General conditions of use

This product is designed and tested to comply with the requirements of IEC/EN61010-1: 2001 + C1 : 2002 + C2 : 2003 'Safety requirements for electrical equipment for measurement, control and laboratory use', for Class I portable equipment and is for use in a pollution degree 2 environment. The equipment is designed to operate from an installation category I or II supply.

Equipment should be protected from the ingress of liquids and precipitation such as rain, snow, etc. When moving the equipment from a cold to a hot environment, it is important to allow the temperature of the equipment to stabilise before it is connected to the supply to avoid condensation forming. The equipment must only be operated within the environmental conditions specified in Chapter 1 'Performance data', otherwise the protection provided by the equipment may be impaired.

This product is not approved for use in hazardous atmospheres or medical applications. If the equipment is to be used in a safety-related application, e.g. avionics or military applications, the suitability of the product must be assessed and approved for use by a competent person.

---

**WARNING****Electrical hazards (AC supply voltage)**

This equipment conforms with IEC Safety Class I, meaning that it is provided with a protective grounding lead. To maintain this protection the supply lead must always be connected to the source of supply via a socket with a grounded contact.

Be aware that the supply filter contains capacitors that may remain charged after the equipment is disconnected from the supply. Although the stored energy is within the approved safety requirements, a slight shock may be felt if the plug pins are touched immediately after removal.

Do not remove instrument covers as this may result in personal injury. There are no user-serviceable parts inside.

Refer all servicing to qualified personnel. See list of Service Centers at rear of manual.

**Fuses**

Note that the internal supply fuse is in series with the live conductor of the supply lead. If connection is made to a 2-pin unpolarized supply socket, it is possible for the fuse to become transposed to the neutral conductor, in which case, parts of the equipment could remain at supply potential even after the fuse has ruptured.

**WARNING****Fire hazard**

Make sure that only fuses of the correct rating and type are used for replacement.

If an integrally fused plug is used on the supply lead, ensure that the fuse rating is commensurate with the current requirements of this equipment. See under 'Performance Data' in Chapter 1 for power requirements.

**WARNING****Toxic hazards**

Some of the components used in this equipment may include resins and other materials which give off toxic fumes if incinerated. Take appropriate precautions, therefore, in the disposal of these items.

**WARNING****Lithium**

A Lithium battery (or a Lithium battery contained within an IC) is used in this equipment:

As Lithium is a toxic substance, the battery should in no circumstances be crushed, incinerated or disposed of in normal waste.

Do not attempt to recharge this type of battery. Do not short circuit or force discharge since this might cause the battery to vent, overheat or explode.

---

**WARNING****Beryllium copper**

Some mechanical components within this instrument are manufactured from beryllium copper. This is an alloy with a beryllium content of approximately 5%. It represents no risk in normal use. The material should not be machined, welded or subjected to any process where heat is involved. It must be disposed of as “special waste”. It must NOT be disposed of by incineration.

**WARNING****Nickel metal hydride**

A Nickel Metal Hydride (Ni-MH) battery pack is used in this equipment. Do not attempt to open, disassemble or mutilate the battery pack. The battery pack does not contain any user serviceable components and cannot be repaired. Under abnormal conditions, the battery pack can explode, leak or catch fire if exposed to high temperatures/fire, or if it is opened or disassembled. Do not short circuit the battery pack terminals.

This battery pack contains an absorbed CORROSIVE potassium hydroxide electrolyte which can cause burns to the eyes and skin, and nickel hydroxide which is HARMFUL if inhaled or if it comes into contact with the skin, resulting in possible sensitization of the affected area. In all cases, rinse the affected area with plenty of water and seek medical advice. Use protective gloves when handling a damaged battery.

If the battery has leaked or vented, it must be replaced immediately. Replace only with an identical battery from the same manufacturer or with a type recommended by Aeroflex. Remove the instrument power lead before removing the battery pack.

The battery pack contains a smart charge management system and must only be charged using the charging facilities in the equipment, or by using an approved battery charger.

European legislation (EC Directive 91/689/EEC) classifies Ni-MH batteries as hazardous waste due to the nickel content. Collect spent batteries separately for disposal, do not mix with other waste streams. Contact your local battery supplier for up-to-date information on the collection, disposal or recycling procedures for your country.

**WARNING****Hot Surfaces**

Take care when touching the RF Input Type N connector after the application of high levels of continuous power. If 50 W is exceeded for a prolonged period, the temperature of the connector can become excessive.

---

**WARNING****RF hazard**

When measuring high VSWR ratios, hazardous voltages may be present on the line due to standing waves. Under these conditions, it is dangerous to operate the equipment with the covers removed.

**WARNING****Tilt facility**

When the equipment is in the tilt position, it is advisable, for stability reasons, not to stack other equipment on top of it.

**CAUTION****Suitability for use**

This equipment has been designed and manufactured by Aeroflex to generate low-power RF signals for testing radio communications apparatus.

If the equipment is not used in a manner specified by Aeroflex, the protection provided by the equipment may be impaired.

Aeroflex has no control over the use of this equipment and cannot be held responsible for events arising from its use other than for its intended purpose.



---

# Precautions

**WARNING**

**CAUTION**

**Note**

Les termes suivants ont, dans ce manuel, des significations particulières:

**WARNING**

contient des informations pour éviter toute blessure au personnel.

**CAUTION**





contient des informations pour éviter les dommages aux équipements.

**Note**

contient d'importantes informations d'ordre général.

## Symboles signalant un risque

La signification des symboles de danger apparaissant sur l'équipement et dans la documentation est la suivante:

Symbole	Nature du risque
	Reportez-vous au manuel d'utilisation quand ce symbole apparaît sur l'instrument. Familiarisez-vous avec la nature du danger et la conduite à tenir.
	Tension dangereuse
	Danger produits toxiques
	Surfaces chaudes

## Conditions générales d'utilisation

Ce produit a été conçu et testé pour être conforme aux exigences des normes CEI/EN61010-1 :2001 + C1 : 2002 + C2 : 2003 « exigences de sécurité des équipements électriques pour la mesure, le contrôle et l'usage en laboratoire », pour des équipements Classe I portables et pour une utilisation dans un environnement de pollution de niveau 2. Cet équipement est conçu pour fonctionner à partir d'une alimentation de catégorie I ou II.

Cet équipement doit être protégé de l'introduction de liquides ainsi que des précipitations d'eau, de neige, etc... Lorsqu'on transporte cet équipement d'un environnement chaud vers un environnement froid, il est important de laisser l'équipement se stabiliser en température avant de le connecter à une alimentation afin d'éviter toute formation de condensation. L'appareil doit être utilisé uniquement dans le cadre des conditions d'environnement spécifiées au chapitre 1 "Performance data", toute autre utilisation peut endommager les systèmes de protection.

Ce produit n'est pas garanti pour fonctionner dans des atmosphères dangereuses ou pour un usage médical. Si l'équipement doit être utilisé pour des applications en relation avec la sécurité, par exemple des applications militaires ou aéronautiques, la compatibilité du produit doit être établie et approuvée par une personne compétente.

---

**WARNING**

## Sécurité électrique (tension d'alimentation alternative)

Cet appareil est protégé conformément à la norme CEI de sécurité Classe 1, c'est-à-dire que sa prise secteur comporte un fil de protection à la terre. Pour maintenir cette protection, le câble d'alimentation doit toujours être branché à la source d'alimentation par l'intermédiaire d'une prise comportant une borne de terre.

Notez que les filtres d'alimentation contiennent des condensateurs qui peuvent encore être chargés lorsque l'appareil est débranché. Bien que l'énergie contenue soit conforme aux exigences de sécurité, il est possible de ressentir un léger choc si l'on touche les bornes sitôt après débranchement.

Ne démontez pas le capot de l'instrument, car ceci peut provoquer des blessures. Il n'y a pas de pièces remplaçables par l'utilisateur à l'intérieur.

Faites effectuer toute réparation par du personnel qualifié. Contacter un des Centres de Maintenance Internationaux dans la liste jointe à la fin du manuel.

### Fusibles

Notez que le fusible d'alimentation interne est en série avec la phase du câble d'alimentation. Si la prise d'alimentation comporte deux bornes non polarisées, il est possible de connecter le fusible au neutre. Dans ce cas, certaines parties de l'appareil peuvent rester à un certain potentiel même après coupure du fusible.

**WARNING**

## Risque lié au feu

Lors du remplacement des fusibles vérifiez l'exactitude de leur type et de leur valeur.

Si le câble d'alimentation comporte une prise avec fusible intégré, assurez vous que sa valeur est compatible avec les besoins en courant de l'appareil. Pour la consommation, reportez-vous au Chapitre 1 "Spécifications".

**WARNING**

## Danger produits toxiques

Certains composants utilisés dans cet appareil peuvent contenir des résines et d'autres matières qui dégagent des fumées toxiques lors de leur incinération. Les précautions d'usages doivent donc être prises lorsqu'on se débarrasse de ce type de composant.

**WARNING**

## Lithium

Une pile au Lithium ou un CI contenant une pile au Lithium est utilisé dans cet équipement.

Le Lithium est une substance toxique; en conséquence on ne doit l'écraser, l'incinérer ou la jeter dans la "poubelle".

Ne pas essayer de la recharger, ne pas la court-circuiter, une forte décharge rapide risque de provoquer une surchauffe voire l'explosion de celle-ci.

---

**WARNING**

## Bronze au béryllium

Dans cet équipement, certaines pièces mécaniques sont à base de bronze au béryllium. Il s'agit d'un alliage dans lequel le pourcentage de béryllium ne dépasse pas 5%. Il ne présente aucun danger en utilisation normale.

Toutefois, cet alliage ne doit pas être travaillé, soudé ou soumis à un processus qui implique l'utilisation d'une source de chaleur.

En cas de destruction, il sera entreposé dans un container spécial. IL ne devra pas être détruit par incinération.



## Nickel Hydrure

Un pack batterie au Nickel Hydrure (Ni-MH) est utilisé dans cet équipement. Ne pas écraser, transpercer, ouvrir, démonter ou intervenir mécaniquement de quelque façon que ce soit. Le pack batterie ne contient pas de composants réparables. Sous des conditions anormales, le pack batterie peut exploser, fuir, ou prendre feu si on l'expose aux températures élevées ou au feu, ou si on l'ouvre ou le démonte. Ne pas court-circuiter les bornes.

Ce pack batterie contient un électrolyte hydroxyde de potassium qui est corrosif, pouvant causer des brûlures chimiques aux yeux et sur la peau, ainsi que de l'hydroxyde de nickel qui est nocif lorsqu'il est inhalé ou en contact avec la peau. En cas de contact avec la peau, laver immédiatement la surface touchée avec beaucoup d'eau et s'adresser à un service médical. Utiliser des gants de protection lorsque l'on touche une batterie endommagée.

Si la batterie a eu une fuite ou une ventilation, il faut la remplacer immédiatement. Utilisez seulement une batterie identique du même fabricant ou avec un modèle recommandé par Aeroflex. Débrancher le câble d'alimentation avant de remplacer le pack batterie.

Le pack batterie contient un système de régulation intelligent, donc il faut seulement utiliser le système de rechargement interne ou un chargeur agréé.

Les batteries du type Ni-MH, suivant les Normes Européennes (EC Directive 91/689/EEC), sont considérées comme des déchets dangereux parce qu'elles contiennent du nickel. Garder les batteries qui ne sont plus utilisables séparément; ne les jetez pas avec les déchets industriels ou domestiques. Contacter votre fournisseur local de batteries pour tout renseignement sur les procédures de rassemblement, enlèvement ou recyclage dans votre pays.

**WARNING**

## Surfaces chaudes

Faire attention ,lors de la manipulation d'un connecteur "N", après l'injection de haute puissance en continu sur l'entrée RF de ce connecteur: Si une puissance supérieure à 50 W est envoyée pendant une longue durée, la température du connecteur peut être très élevée.

**WARNING**

## Danger RF

Lors de la mesure de T.O.S. de valeur importante, des tensions dangereuses dues aux ondes stationnaires peuvent apparaître sur l'alimentation. Dans ces conditions il est dangereux de faire fonctionner l'appareil sans ses capots de protection.

---

**WARNING****Position inclinée**

Lorsque l'appareil est dans une position inclinée, il est recommandé, pour des raisons de stabilité, de ne pas y empiler d'autres appareils.

**CAUTION****Utilisation**

Cet équipement a été conçu et fabriqué par Aeroflex pour générer des signaux RF de faible puissance pour le test d'appareils de radio communications.

La protection de l'équipement peut être altérée s'il n'est pas utilisé dans les conditions spécifiées par Aeroflex.

Aeroflex n'a aucun contrôle sur l'usage de l'instrument, et ne pourra être tenu pour responsable en cas d'événement survenant suite à une utilisation différente de celle prévue.

---

# Vorsichtsmassnahmen

**WARNING**

**CAUTION**

**Note**

Diese Hinweise haben eine bestimmte Bedeutung in diesem Handbuch:

**WARNING**

dienen zur Vermeidung von Verletzungsrisiken.

**CAUTION**





dienen dem Schutz der Geräte.

**Note**

enthalten wichtige Informationen.

## Gefahrensymbole

Die Bedeutung der Gefahrensymbole auf den Geräten und in der Dokumentation ist wie folgt:

Symbol	Gefahrenart
	Beziehen Sie sich auf die Bedienungsanleitung wenn das Messgerät mit diesem Symbol markiert ist. Machen Sie sich mit der Art der Gefahr und den Aktionen die getroffen werden müssen bekannt.
	Gefährliche Spannung
	Warnung vor giftigen Substanzen
	Heiße Oberfläche

## Allgemeine Hinweise zur Verwendung

Dieses Produkt wurde entsprechend den Anforderungen von IEC/EN61010-1: 2001 + C1 : 2002 + C2 : 2003 "Sicherheitsanforderungen für elektrische Ausrüstung für Meßaufgaben, Steuerung und Laborbedarf", Klasse I transportabel zur Verwendung in einer Grad 2 verunreinigten Umgebung, entwickelt und getestet. Dieses Gerät ist für Netzversorgung Klasse I oder II zugelassen.

Das Gerät sollte vor dem Eindringen von Flüssigkeiten sowie vor Regen, Schnee etc. geschützt werden. Bei Standortänderung von kalter in wärmere Umgebung sollte das Gerät wegen der Kondensation erst nach Anpassung an die wärmere Umgebung mit dem Netz verbunden werden. Das Gerät darf nur in Umgebungsbedingungen wie in Kapitel 1 "Leistungsdaten (Performance data)" beschrieben, betrieben werden; ansonsten wird der vom Gerät vorgesehene Schutz des Anwenders beeinträchtigt.

Dieses Produkt ist nicht für den Einsatz in gefährlicher Umgebung (z.B. Ex-Bereich) und für medizinische Anwendungen geprüft. Sollte das Gerät für den Einsatz in sicherheitsrelevanten Anwendungen wie z.B. im Flugverkehr oder bei militärischen Anwendungen vorgesehen sein, so ist dieser von einer für diesen Bereich zuständigen Person zu beurteilen und genehmigen.

---

**WARNING**

## Elektrische Schläge (Wechselspannungsversorgung)

Das Gerät entspricht IEC Sicherheitsklasse 1 mit einem Schutzleiter nach Erde. Das Netzkabel muß stets an eine Steckdose mit Erdkontakt angeschlossen werden.

Filterkondensatoren in der internen Spannungsversorgung können auch nach Unterbrechung der Spannungszuführung noch geladen sein. Obwohl die darin gespeicherte Energie innerhalb der Sicherheitsmargen liegt, kann ein leichter Spannungsschlag bei Berührung kurz nach der Unterbrechung erfolgen.

Öffnen Sie niemals das Gehäuse der Geräte das dies zu ernsthaften Verletzungen führen kann. Es gibt keine vom Anwender austauschbare Teile in diesem Gerät.

Lassen Sie alle Reparaturen durch qualifiziertes Personal durchführen. Eine Liste der Servicestellen finden Sie auf der Rückseite des Handbuchs.

### Sicherungen

Die interne Sicherung in der Spannungszuführung ist in Reihe mit der spannungsführenden Zuleitung geschaltet. Bei Verbindung mit einer zweiadrigen, nicht gepolten Steckdose kann die Sicherung in der Masseleitung liegen, so daß auch bei geschmolzener Sicherung Geräteteile immer noch auf Spannungspotential sind.

**WARNING**

## Feuergefahr

Es dürfen nur Ersatzsicherungen vom gleichen Typ mit den korrekten Spezifikationen entsprechend der Stromaufnahme des Gerätes verwendet werden. Siehe hierzu die Leistungsdaten (Performance Data) in Kapitel 1.

**WARNING**

## Warnung vor giftigen Substanzen

In einigen Bauelementen dieses Geräts können Epoxyharze oder andere Materialien enthalten sein, die im Brandfall giftige Gase erzeugen. Bei der Entsorgung müssen deshalb entsprechende Vorsichtsmaßnahmen getroffen werden.

**WARNING**

## Lithium

Eine Lithium Batterie oder eine Lithium Batterie innerhalb eines IC ist in diesem Gerät eingebaut.

Da Lithium ein giftiges Material ist, sollte es als Sondermüll entsorgt werden.

Diese Batterie darf auf keinen Fall geladen werden. Nicht kurzschließen, da sie dabei überhitzt werden und explodieren kann.

---

**WARNING**

## Beryllium Kupfer

In diesem Gerät sind einige mechanische Komponenten aus Beryllium Kupfer gefertigt. Dies ist eine Verbindung welche aus einem Berylliumanteil von ca. 5 % besteht. Bei normaler Verwendung besteht kein Gesundheitsrisiko.

Das Metall darf nicht bearbeitet, geschweißt oder sonstiger Wärmebehandlung ausgesetzt werden. Es muß als Sondermüll entsorgt werden.

Es darf nicht durch Verbrennung entsorgt werden.

**WARNING**

## Nickel Metalhydride

In diesem Gerät wird ein Nickel-Metalhydrid (Ni-MH) Akkusatz verwendet. Versuchen Sie nicht diesen zu öffnen, auszubauen oder zu zerstören. Der Akkusatz beinhaltet keine vom Anwender auszutauschenden Teile und kann auch nicht repariert werden. Unter abnormalen Bedingungen kann der Akkusatz, falls ausgebaut oder geöffnet, explodieren, auslaufen oder bei hohen Temperaturen auch Feuer fangen. Schließen sie die Akkuanschlüsse niemals kurz.

Der Akkusatz enthält neben einem ätzenden Kalium-Hydroxid Elektrolyten welcher Verätzungen des Auges und der Haut hervorrufen kann auch Nickel-Hydroxid welches sich bei Einatmung zur Schädigungen führt oder Berührung mit der Haut eine Reizung des betroffenen Bereiches bewirkt. In allen Fällen ist die betroffene Stelle mit ausreichend Wasser zu berieseln und ärztliche Hilfe in Anspruch zu nehmen. Verwenden Sie bei der Handhabung von beschädigen Akkus Schutzhandschuhe.

Sollte der Akkusatz auslaufen oder eine mechanische Beschädigung aufweisen, so ist er umgehend zu entfernen. Ersetzen Sie diesen nur durch einen identischen Akkusatz des gleichen Herstellers oder mit einem Typ wie er von Aeroflex empfohlen wird. Stecken Sie vor dem Entfernen des Akkusatzes das Netzkabel aus.

Der Akkusatz enthält eine spezielles Ladeüberwachungsschaltung und darf nur mit der Ladeeinrichtung des zugehörigen Gerätes oder einem passenden Ladegerät geladen werden.

Die Europäische Gesetzgebung (EC Richtline 91/689/EEC) stuft Ni-MH Akkus wegen ihres Anteils an Nickel als gefährlichen Abfall ein. Sammeln Sie verbrauchte Akkus getrennt und mischen Sie diese nicht mit anderem Abfall. Fragen Sie den in Ihrem Land zuständigen Hersteller bezüglich Sammlung, Entsorgung und Wiederaufarbeitung von verbrauchten Akkus.

**WARNING**

## Heiße Oberfläche

Vorsicht bei Berührung der HF Eingangsbuchse Typ N nach Einspeisen hoher Dauerleistung. Falls über längere Zeit 50 Watt überschritten wird, kann die Temperatur der Buchse über Normal steigen.

**WARNING**

## Hochfrequenz

Bei Messung von hohen Stehwellenverhältnissen können sich auf der Leitung gefährliche Spannungen aufbauen. In solchen Fällen darf das Gerät nicht bei geöffnetem Gehäuse betrieben werden.

---

**WARNING****Schrägstellung**

Bei Schrägstellung des Geräts sollten aus Stabilitätsgründen keine anderen Geräte darauf gestellt werden.

**CAUTION****Eignung für Gebrauch**

Dieses Gerät wurde von Aeroflex entwickelt und hergestellt um HF Signale geringer Leistung zum Test von Kommunikationseinrichtungen zu erzeugen.

Sollte das Gerät nicht auf die von Aeroflex vorgesehene Art und Weise verwendet werden, kann die Schutzfunktion des Gerätes beeinträchtigt werden.

Aeroflex hat keinen Einfluß auf die Art der Verwendung und übernimmt keinerlei Verantwortung bei unsachgemässer Handhabung.



---

# Precauzioni

**WARNING**

**CAUTION**

**Note**

Questi termini vengono utilizzati in questo manuale con significati specifici:

**WARNING**

riportano informazioni atte ad evitare possibili pericoli alla persona.

**CAUTION**





riportano informazioni per evitare possibili pericoli all'apparecchiatura.

**Note**

riportano importanti informazioni di carattere generale.

## Simboli di pericolo

Il significato del simbolo di pericolo riportato sugli strumenti e nella documentazione è il seguente:

Simbolo	Tipo di pericolo
	Fare riferimento al manuale operativo quando questo simbolo è riportato sullo strumento. Rendervi conto della natura del pericolo e delle precauzioni che dovrete prendere.
	Tensione pericolosa
	Pericolo sostanze tossiche
	Superfici ad alta temperatura

## Condizioni generali d'uso.

Questo prodotto è stato progettato e collaudato per rispondere ai requisiti della direttiva IEC/EN61010-1: 2001 + C1 : 2002 + C2 : 2003 'Safety requirements for electrical equipment for measurement, control and laboratory use' per apparati di classe I portatili e per l'uso in un ambiente inquinato di grado 2. L'apparato è stato progettato per essere alimentato da un alimentatore di categoria I o II.

Lo strumento deve essere protetto dal possibile ingresso di liquidi quali, ad es., acqua, pioggia, neve, ecc. Qualora lo strumento venga portato da un ambiente freddo ad uno caldo, è importante lasciare che la temperatura all'interno dello strumento si stabilizzi prima di alimentarlo per evitare formazione di condense. Lo strumento deve essere utilizzato esclusivamente nelle condizioni ambientali descritte nel capitolo 1 'Performance data', in caso contrario le protezioni previste nello strumento potrebbero risultare non sufficienti.

Questo prodotto non è stato approvato per essere usato in ambienti pericolosi o applicazioni medicali. Se lo strumento deve essere usato per applicazioni particolari collegate alla sicurezza (per esempio applicazioni militari o avioniche), occorre che una persona o un istituto competente ne certifichi l'uso.

---

**WARNING****Pericoli da elettricità (alimentazione c.a.)**

Quest' apparato è provvisto del collegamento di protezione di terra e rispetta le norme di sicurezza IEC, classe 1. Per mantenere questa protezione è necessario che il cavo, la spina e la presa d'alimentazione siano tutti provvisti di terra.

Il circuito d'alimentazione contiene dei filtri i cui condensatori possono restare carichi anche dopo aver rimosso l'alimentazione. Sebbene l'energia immagazzinata è entro i limiti di sicurezza, purtuttavia una leggera scossa può essere avvertita toccando i capi della spina subito dopo averla rimossa.

Non rimuovete mai le coperture perché così potreste provocare danni a voi stessi. Non vi sono all'interno parti di interesse all'utilizzatore.

Tutte gli interventi sono di competenza del personale qualificato. Vedi elenco internazionale dei Centri di Assistenza in fondo al manuale.

**Fusibili**

Notare che un fusibile è posto sul filo caldo del cavo di alimentazione. Qualora l'alimentazione avvenga tramite due poli non polarizzati, è possibile che il fusibile vada a protezione del neutro per cui anche in caso di una sua rottura, l'apparato potrebbe restare sotto tensione.

**WARNING****Pericolo d'incendio**

Assicurarsi che, in caso di sostituzione, vengano utilizzati solo fusibili della portata e del tipo prescritti.

Se viene usata una spina con fusibili, assicurarsi che questi siano di portata adeguata coi requisiti di alimentazione richiesti dallo strumento. Tali requisiti sono riportati nel cap. 1 "Performance data".

**WARNING****Pericolo sostanze tossiche**

Alcuni dei componenti usati in questo strumento possono contenere resine o altri materiali che, se bruciati, possono emettere fumi tossici. Prendere quindi le opportune precauzioni nell'uso di tali parti.

**WARNING****Litio**

Quest'apparato incorpora una batteria al litio o un circuito integrato contenente una batteria al litio.

Poiché il litio è una sostanza tossica, la batteria non deve essere mai né rotta, né incenerita, né gettata tra i normali rifiuti.

Questo tipo di batteria non può essere sottoposto né a ricarica né a corto-circuito o scarica forzata. Queste azioni possono provocare surriscaldamento, fuoriuscita di gas o esplosione della batteria.

---

**WARNING****Rame berillio**

Alcuni componenti meccanici in questo strumento sono realizzati in rame berillio. Si tratta di una lega con contenuto di berillio di circa il 5%, che non presenta alcun rischio in usi normali.

Questo materiale non deve essere lavorato, saldato o subire qualsiasi processo che coinvolge alte temperature.

Deve essere eliminato come "rifiuto speciale". Non deve essere eliminato tramite "inceneritore".

**WARNING****Nickel-Metallo Idrido**

Quest'apparato contiene un pacco batterie al Nickel-Metallo Idrido (Ni-MH, Nickel Metal Hydride) che non deve essere aperto, disassemblato o mutilato di alcuna parte. Il pacco batterie non contiene parti riutilizzabili né può essere riparato. In particolari condizioni (anormali) esso può esplodere, può gocciolare o infiammarsi se esposto ad alte temperature o messo a contatto col fuoco o se aperto o disassemblato. Non corto-circuitare i poli.

Questo pacco batterie contiene idrossido di potassio, un elettrolito **CORROSIVO** che può causare bruciature agli occhi ed alla pelle e sensibilizzare l'area con cui viene a contatto. In ogni evenienza lavare l'area interessata con abbondante acqua corrente e rivolgersi ai consigli di un medico. Usare guanti protettivi quando si maneggia un pacco batterie danneggiato.

Se la batteria gocciola o è forata, va sostituita immediatamente. La sostituzione deve essere fatta solo con analoga batteria, dello stesso costruttore, o con un tipo raccomandato dalla Aeroflex. Prima di rimuovere la batteria, occorre scollegare il cavo di alimentazione elettrica esterna dell'apparato.

Il pacco batterie contiene un sistema intelligente di ricarica per cui esso va ricaricato solo tramite questo apparato o tramite un carica-batterie approvato.

La legislazione europea (direttiva CE n. 9/889/EEC) classifica le batterie Ni-MH tra i rifiuti pericolosi a causa del suo contenuto di nickel. Le batterie esaurite vanno pertanto raccolte negli appositi contenitori di rifiuti e non vanno mescolate ad altri rifiuti...Contattare il locale fornitore di batterie per le necessarie informazioni sulle procedure vigenti nel Vostro paese sulla raccolta di rifiuti e sull-immagazzinamento di questo tipo di batterie.

**WARNING****Superfici ad alta temperatura**

Fare attenzione nel toccare il connettore d'ingresso di tipo N dopo aver applicato una potenza elevata e continua. Una potenza superiore a 50 W per tempi prolungati può portare il connettore ad una temperatura molto elevata.

**WARNING****Rischio a RF**

Durante la misura di ROS di valori elevati, la presenza di onde stazionarie può causare tensioni pericolose. In queste condizioni è quindi rischioso usare lo strumento coi coperchi rimossi.

---

**WARNING****Posizionamento inclinato**

Quando lo strumento è in posizione inclinata è raccomandato, per motivi di stabilità, non sovrapporre altri strumenti.

**CAUTION****Caratteristiche d'uso**

Questo strumento è stato progettato e prodotto da Aeroflex generare segnali RF in bassa potenza per provare apparati di radio comunicazione.

Se lo strumento non è utilizzato nel modo specificato da Aeroflex, le protezioni previste sullo strumento potrebbero risultare inefficaci.

Aeroflex non può avere il controllo sull'uso di questo strumento e non può essere ritenuta responsabile per eventi risultanti da un uso diverso dallo scopo prefisso.

---

# Precauciones

**WARNING**

**CAUTION**

**Note**

Estos términos tienen significados específicos en este manual:

**WARNING**

contienen información referente a prevención de daños personales.

**CAUTION**





contienen información referente a prevención de daños en equipos.

**Note**

contienen información general importante.

## Símbolos de peligro

El significado de los símbolos de peligro en el equipo y en la documentación es el siguiente:

Símbolo	Naturaleza del peligro
	Vea el manual de funcionamiento cuando este símbolo aparezca en el instrumento. Familiarícese con la naturaleza del riesgo y con las acciones que deban de tomarse.
	Voltaje peligroso
	Aviso de toxicidad
	Superficies a altas temperaturas

## Condiciones generales de uso

Este producto ha sido diseñado y probado para cumplir los requerimientos de la normativa IEC/EN61010-1: 2001 + C1 : 2002 + C2 : 2003 "Requerimientos de la normativa para equipos eléctricos de medida, control y uso en laboratorio", para equipos clase I portátiles y para uso en un ambiente con un grado de contaminación 2. El equipo ha sido diseñado para funcionar sobre una instalación de alimentación de categorías I o II.

Debe protegerse el equipo de la entrada de líquidos y precipitaciones como nieve, lluvia, etc. Cuando se traslada el equipo de entorno frío a un entorno caliente, es importante aguardar la estabilización del equipo para evitar la condensación. Sólo debe utilizarse el aparato en las condiciones ambientales especificadas en el capítulo 1 "Especificaciones" o "Performance data", en caso contrario la propia protección del equipo puede resultar dañada.

No retire las cubiertas del chasis del instrumento, ya que pudiera resultar dañado personalmente. No existen partes que puedan ser reparadas en su interior.

Deje todas las tareas relativas a reparación a un servicio técnico cualificado. Vea la lista de Centros de Servicios Internacionales en la parte trasera del manual.

---

**WARNING**

## Nivel peligroso de electricidad (tensión de red)

Este equipo cumple las normas IEC Seguridad Clase 1, lo que significa que va provisto de un cable de protección de masa. Para mantener esta protección, el cable de alimentación de red debe de conectarse siempre a una clavija con terminal de masa.

Tenga en cuenta que el filtro de red contiene condensadores que pueden almacenar carga una vez desconectado el equipo. Aunque la energía almacenada está dentro de los requisitos de seguridad, pudiera sentirse una ligera descarga al tocar la clavija de alimentación inmediatamente después de su desconexión de red.

No quitar las tapas, en el interior no existen piezas reemplazables por el usuario. Vea la lista de Centros de Servicios Internacionales en la parte trasera del manual.

## Fusibles

Se hace notar que el fusible de alimentación interno está en serie con el activo del cable de alimentación a red. Si la clavija de alimentación de red cuenta con sólo dos terminales sin polaridad, el fusible puede pasar a estar en serie con el neutro, en cuyo caso existen partes del equipo que permanecerían a tensión de red incluso después de que el fusible haya fundido.

**WARNING**

## Peligro de incendio

Asegúrese de utilizar sólo fusibles del tipo y valores especificados como repuesto.

Si se utiliza una clavija con fusible incorporado, asegúrese de que los valores del fusible corresponden a los requeridos por el equipo. Ver sección de especificaciones del capítulo 1 para comprobar los requisitos de alimentación.

**WARNING**

## Aviso de toxicidad

Alguno de los componentes utilizados en este equipo pudieran incluir resinas u otro tipo de materiales que al arder produjeran sustancias tóxicas. Por tanto, tome las debidas precauciones en la manipulación de esas piezas.

**WARNING**

## Litio

En este equipo se utiliza una batería de litio (o contenida dentro de un CI).

Dada que el litio es una sustancia tóxica las baterías de este material no deben ser aplastadas, quemadas o arrojadas junto a basuras ordinarias.

No trate de recargar este tipo de baterías. No las cortocircuite o fuerce su descarga ya que puede dar lugar a que la esta emita gases, se recaliente o explote.

---

**WARNING****Berilio-cobre**

Algunos componentes mecánicos contenidos en este instrumento incorporan berilio-cobre en su proceso de fabricación. Se trata de una aleación con un contenido aproximado de berilio del 5%, lo que no representa ningún riesgo durante su uso normal.

El material no debe ser manipulado, soldado, ni sometido a ningún proceso que implique la aplicación de calor.

Para su eliminación debe tratarse como un "residuo especial". El material NO DEBE eliminarse mediante incineración.

**WARNING****Níquel Hidruro Metálico (Ni-MH).**

Este equipo utiliza un paquete de baterías híbrido Níquel Hidruro Metálico(Ni-MH). No intente abrir, desmantelar o mutilar el paquete de baterías. El paquete de baterías no contiene ningún componente reemplazable por el usuario y no puede ser reparado. Bajo circunstancias anormales, el paquete de baterías puede explotar, tener fugas o arder si es expuesto a altas temperaturas o fuego o si es abierto o desmontado. No cortocircuite los terminales del paquete de baterías.

Este paquete de baterías contiene un electrolito de hidróxido potásico absorbido corrosivo que puede causar quemaduras en los ojos y en la piel, así como hidróxido de Níquel, que es nocivo por inhalación o por contacto con la piel, produciendo como consecuencia una posible desensibilización del área afectada. En todos los casos, lave la zona afectada con abundante agua y busque consejo médico. Use guantes de protección cuando manipule una batería dañada.

Si el paquete de baterías ha sufrido pérdidas a fugas de gases, debe reemplazarse inmediatamente.

Reemplázela con una batería idéntica del mismo fabricante o con un tipo recomendado por Aeroflex. Desconecte el cable de alimentación del equipo antes de quitar el paquete de baterías.

**WARNING****Superficies a altas temperaturas**

Tenga cuidado al tocar el conector de entrada RF tipo N tras la aplicación continuada de altos niveles de potencia. La temperatura del conector puede llegar a ser excesiva si se sobrepasan 50 W durante un periodo prolongado de tiempo.

**WARNING****Riesgo de RF**

Cuando se miden valores elevados de ROE, pueden existir tensiones elevadas debido a ondas estacionarias. Bajo estas condiciones resulta peligroso operar con el equipo sin las tapas puestas.

**WARNING****Tener en cuenta con el equipo inclinado**

Si utiliza el equipo en posición inclinada, se recomienda, por razones de estabilidad, no apilar otros equipos encima de él.

---

**CAUTION****Idoneidad de uso**

Este equipo ha sido diseñado y fabricado por Aeroflex para generar señales de RF de bajo nivel para probar equipos de radiocomunicaciones.

Si el equipo fuese utilizado de forma diferente a la especificada por Aeroflex, la protección ofrecida por el equipo pudiera quedar reducida.

Aeroflex no tiene control sobre el uso de este equipo y no puede, por tanto, exigirsele responsabilidades derivadas de una utilización distinta de aquellas para las que ha sido diseñado.



---

# Chapter 1

## GENERAL INFORMATION

### Contents

Purpose and features .....	1-2
Transmitter testing .....	1-3
Receiver testing.....	1-4
Duplex testing.....	1-5
Spectrum analyzer.....	1-6
AF testing.....	1-6
<b>Performance data.....</b>	<b>1-7</b>
Receiver measurements .....	1-7
Audio analyzer.....	1-9
Transmitter measurements .....	1-11
RF spectrum analyzer .....	1-13
Audio generators.....	1-14
Frequency standard.....	1-14
General.....	1-15
Options and accessories.....	1-16

### List of figures

Fig. 1-1 Transmitter test setup .....	1-3
Fig. 1-2 Receiver test setup.....	1-4
Fig. 1-3 One port duplex test setup.....	1-5
Fig. 1-4 Two port duplex test setup .....	1-5
Fig. 1-5 AF test setup.....	1-6

## Purpose and features

2944B is a portable Communications Service Monitor for carrying out production, routine and maintenance testing on radio transmitters, receivers and two way radio communication equipment. The Service Monitor contains modules to provide facilities equivalent to the following instruments:

RF generator, two audio generators, specialized tones generator, RF power meter, modulation meter, RF counter, AF counter, AF voltmeter, distortion meter, large screen digital oscilloscope, spectrum analyzer and monitoring receiver.

Distortion measuring filters, AF post demodulation filters and IF passband filters are built in for inclusion in relevant measurement paths.

The signal obtained from the demodulators, when in Tx test mode, is fed to an AF amplifier and can be monitored on the built-in loudspeaker, on headphones connected to the accessory socket, or taken from the DEMOD OUT connector to other equipment.

The monitor has a wide range of test capabilities including base station, mobile and transponder commissioning and servicing, radio telephone system and radio pager testing, as well as production testing to all of the above.

The selection of a test mode configures the modules into set-ups ready for connection to the equipment to be tested and produces the appropriate set-up screen on the display. The set-up screen shows the settings of the active modules, records changes to settings as they are made and gives readouts of test results both digitally and on barcharts.

The modules of the monitor can each be used to perform as individual test instruments.

A hard copy of most screens can be made to a suitable printer using the screen capture feature. This is one of the functions accessed after pressing the [DISPLAY HOLD] key on the front panel. See Front panel layout, DISPLAY HOLD key, in Chapter 3.

A memory facility allows instrument settings and test results to be stored within the instrument.

The RS232 control facility permits operation of the instrument by remote or automatic control as an alternative or supplement to the conventional front panel local control.

IEEE 488.2 GPIB remote control is available as an option.

RS232 and GPIB control facilities are detailed fully in the Programming Manual supplied.

The test modes are outlined in the following descriptions, with interconnection diagrams showing the principles of the test procedures.

## Transmitter testing

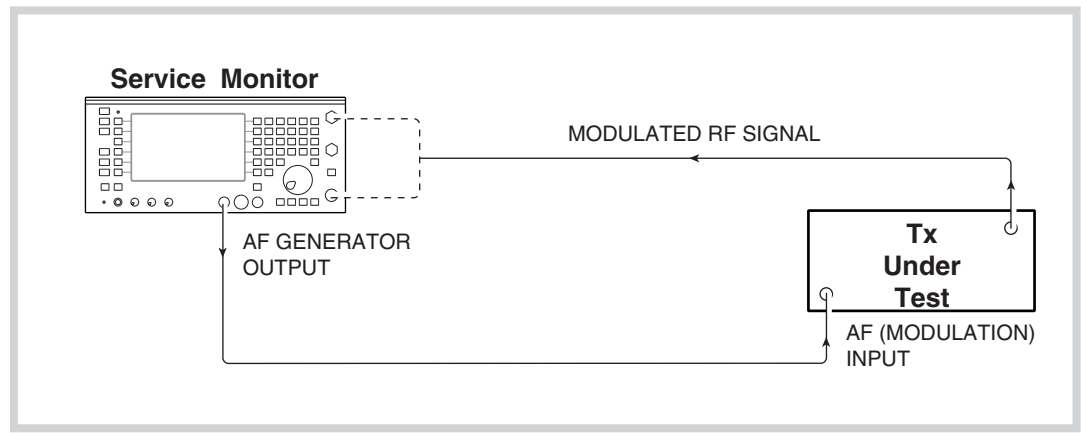

C6025

*Fig. 1-1 Transmitter test setup*

The transmitter test procedure uses:

The AF generators, to provide a source of modulation for the transmitter under test.

The RF power meter, to measure the mean output power level of the transmitter.

The RF counter, to obtain the mean RF frequency of the transmitter output.

The modulation meter, to measure the modulation depth or the deviation level and to provide a demodulated output signal. Single sideband transmissions can be demodulated when the SSB option is implemented.

The AF counter, to measure the frequency of the demodulated signal.

The distortion meter, to obtain the signal to noise level, the modulation distortion percentage or the modulation SINAD level of the transmitter.

The oscilloscope, to view the demodulated signal and to measure the modulation levels.

The tones generator, to modulate transmitters of systems using tone calling.

The tones decoder, to demodulate tones generated by the transmitter.

The AF amplifier and loudspeaker, to monitor the demodulated signal.

The spectrum analyzer facility, which is a separate operating mode (SPEC ANA), can be used to study the sidebands and any harmonics produced by the transmitter, either by direct connection or by off-air monitoring.

## Receiver testing

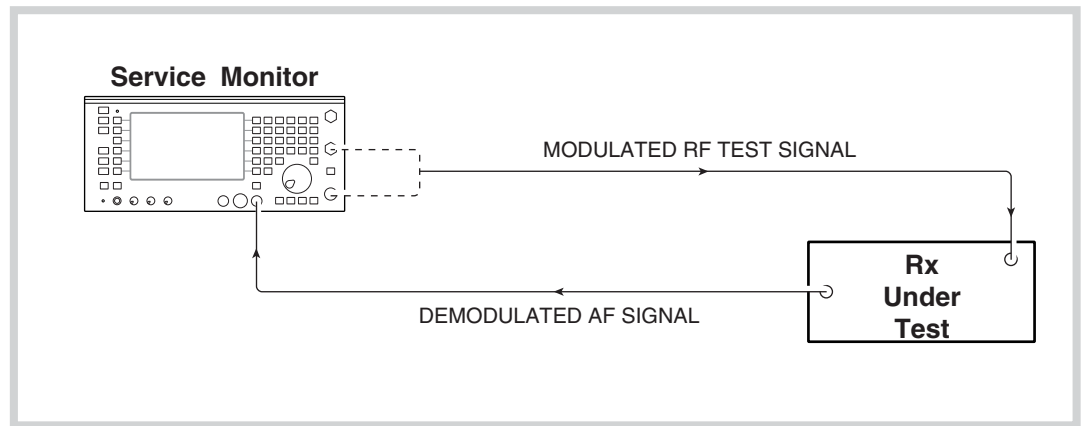

C6026

*Fig. 1-2 Receiver test setup*

The receiver test procedure uses:

- The RF generator and the AF generators, to produce a transmission with defined parameters.

- The AF voltmeter, to measure the level of the demodulated signal from the receiver.

- The distortion meter, to obtain signal-to-noise ratio, SINAD levels and distortion percentage figures.

- The tone generator and tone detector, to produce and decode specialized calling tones to test tone recognition circuits.

- The oscilloscope, to view and measure the demodulated signal or other waveforms.

The RF signal from the Service Monitor is coupled to the receiver and the demodulated signal from the receiver taken to the AF input of the Service Monitor. By measuring the levels of the AF signal from the receiver, the sensitivity of the receiver can be checked. The distortion levels introduced by the receiver can be measured.

During all of the above procedures, the RF levels, the distortion levels and modulation levels can be displayed on bar charts as well as being provided as a digital read-out. The AF waveforms can also be studied using the digital oscilloscope facility.

Duplex testing

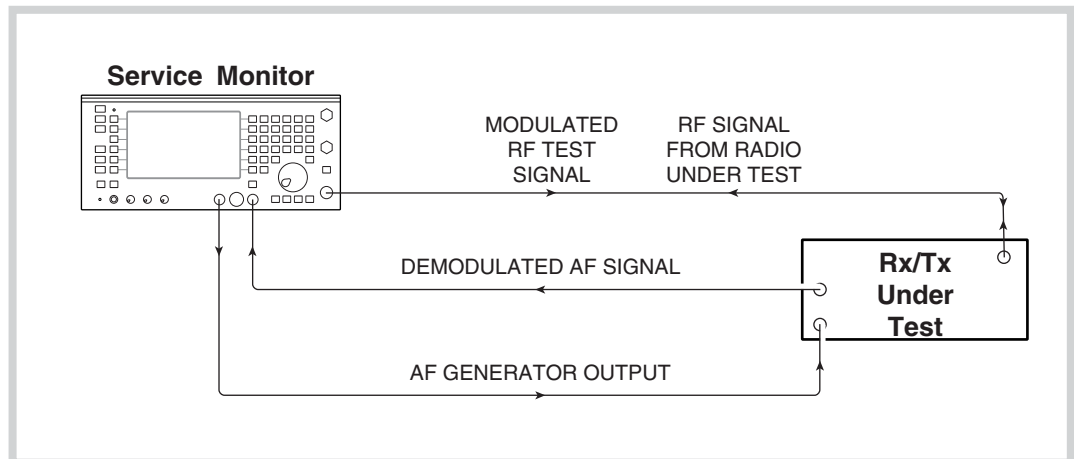

C6027

Fig. 1-3 One port duplex test setup

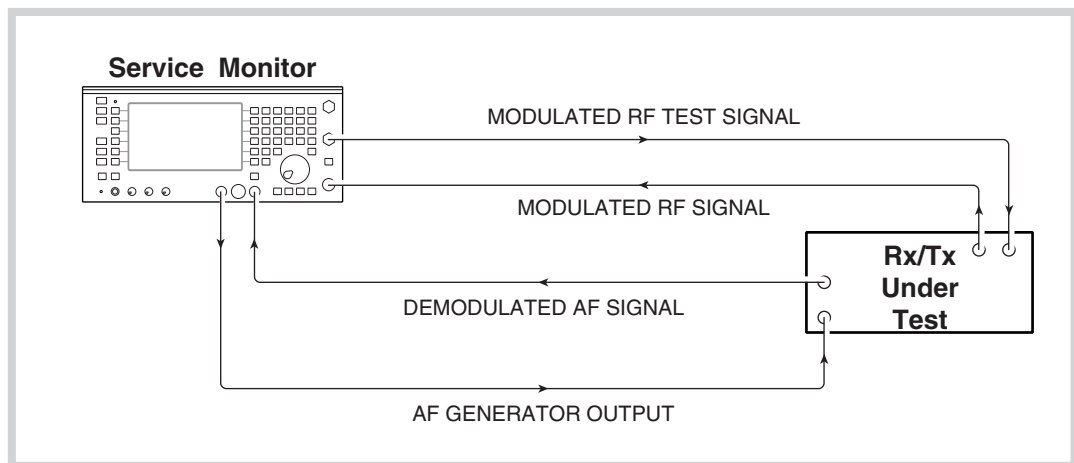

C6028

Fig. 1-4 Two port duplex test setup

Using the Duplex test facility, parameters for transmitter testing and receiver testing can be set up and displayed on one screen. This gives the capability to study the performance of duplex transceivers. Both one-port and two-port units can be tested.

## Spectrum analyzer

The SPEC ANA mode allows 'off air' and directly coupled RF signals to be studied and monitored.

Sideband spread, harmonic levels and RF interference can be examined.

The frequency range of the spectrum analyzer is from 100 kHz to 1.0 GHz with the start and stop frequencies of the sweep infinitely variable from within this range.

The tracking generator permits frequency response tests to be made to frequency dependent circuits and the frequency offset facility extends this capability into the area of frequency shifting circuits, such as mixers.

The 'Look and Listen' function gives the ability to demodulate a signal displayed on the spectrum analyzer and monitor the signal obtained on the built-in loudspeaker, on headphones or other data output equipment.

## AF testing

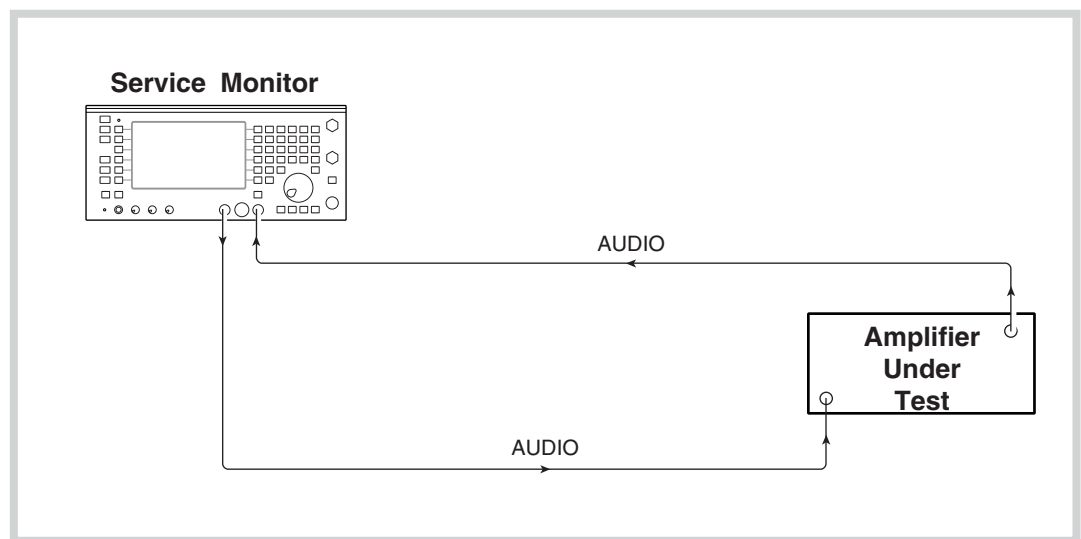

C6029

*Fig. 1-5 AF test setup*

The AF testing mode allows the dual AF generators and the tones generator to be used as a signal source. The AF voltmeter, distortion meter, bar chart displays and the AF counter can all be used to provide data relating to signals applied to the AF input connector. The digital oscilloscope is also available for studying AF waveforms.

## Performance data

### Receiver measurements

#### RF signal generator

##### Frequency

Range	400 kHz to 1.05 GHz
Resolution	10 Hz
Indication	10 digit display
Setting	Keyboard entry, delta increment / decrement function and rotary control
Accuracy	As frequency standard

##### Output Level

Range	N-Type socket: -141 dBm to -21 dBm BNC socket: -115 dBm to +5 dBm (usable to +7 dBm)
Resolution	0.1 dB
Indication	4 digits plus sign (dBm, dB $\mu$ V, $\mu$ V, mV, PD/EMF).
Accuracy	$\pm 2$ dB for level above -127 dBm on N-Type socket up to 1 GHz

##### Attenuator Hold Facility

Allows user to define start point for seamless generator operation across a range of up to 20 dB (guaranteed 10 dB minimum).

##### Reverse Power Protection

N-Type: 50 W for 10 minutes, normal operation. 150 W for 1 minute at 20°C (68°F).  
Overload indicated by audible and visual warning.  
BNC: 5 W Tripping indicated by audible and visual warning.

##### Output Impedance

Nominally 50  $\Omega$

VSWR N-Type	Better than 1.2:1 up to 500 MHz Better than 1.35:1 up to 1.05 GHz
VSWR BNC	Better than 2.2:1 up to 1.05 GHz

##### Spectral Purity

Residual FM	Less than 15 Hz RMS (0.3 to 3.4 kHz) up to 500 MHz. Less than 20 Hz RMS (0.3 to 3.4 kHz) up to 1000 MHz (with OCXO)
Harmonics	Better than -20 dBc
Spurious signals	Better than -30 dBc ( $\pm 10$ kHz to 1.5 MHz offset from carrier frequency or over range 600-700 MHz). Better than -40 dBc from 400 kHz to 1 GHz
SSB phase noise (20 kHz offset)	Better than -95 dBc/Hz up to 1 GHz
RF carrier leakage	Less than 0.5 $\mu$ V PD generated in a 50 $\Omega$ load by a 2-turn loop 25 mm from the case. Output level less than -40 dBm into a sealed 50 $\Omega$ load.

## GENERAL INFORMATION

---

### Amplitude Modulation - Internal

Frequency range	400 kHz to 1.05 GHz
AM depth range	0 to 99 %
Resolution	1 %
Indication	2 digits
Setting	Keyboard entry, delta increment / decrement function and rotary control
Accuracy	For carrier frequencies from 1.5 MHz to 400 MHz: $\pm 7\% \pm 1$ digit, for mod freq of 1 kHz, $\pm 10\% \pm 1$ digit for mod freq of 50 Hz to 5 kHz, $\pm 15\% \pm 1$ digit, for mod freq of 50 Hz to 15 kHz
Distortion	Less than 2% at 1 kHz for 30% AM, CCITT Weighted
Modulation Frequency Range	5 Hz to 33 kHz

### Amplitude Modulation - External

Input impedance	Nominally 10 k $\Omega$ in parallel with 40 pF
Frequency Range	As internal AM
Modulation Frequency Range	As internal AM
Sensitivity	1.0 V RMS for 0 to 100% AM

### Frequency Modulation - Internal

Frequency range	400 kHz to 1.05 GHz
Maximum deviation	0 to 75 kHz
Indication	3 digits
Setting	Keyboard entry, delta increment / decrement function and rotary control
Accuracy †	$\pm 5\% \pm 10$ Hz at 1 kHz modulating frequency $\pm 10\%$ at modulating frequencies from 50 Hz to 15 kHz.
Distortion	Less than 1% at 1 kHz for deviation of 5 kHz, CCITT Weighted.
Mod Frequency Range	5 Hz to 33 kHz
Resolution	25 Hz
Pre-emphasis	750 $\mu$ s selectable

### Frequency Modulation - External

Input impedance	Nominally 10 k $\Omega$ in parallel with 40 pF
Frequency Range	As internal FM
Modulation Frequency Range	DC to 100 kHz
Pre-emphasis	750 $\mu$ s selectable
Sensitivity	1 V RMS for 0 to 75 kHz deviation

### Microphone Input

Input Level	2 mV to 200 mV (AGC leveled)
Input Impedance	Nominally 150 $\Omega$
Press To Talk (PTT)	When using the optional microphone in Tx Test mode, the PTT will switch instrument to Rx Test.

† At low modulation levels the residual AM / FM may become significant



## GENERAL INFORMATION

---

### Audio analyzer

#### Audio Voltmeter

Input Impedance	Nominally 1 M $\Omega$ in parallel with 40 pF
Frequency Range	DC and 50 Hz to 50 kHz AC only 50 Hz to 50 kHz Polarized DC (below 1 Hz)
Level Ranges	0-100 mV to 0-30 V RMS in a 1,3,10 sequence Digital readout also in mW, dBm, dBV, dBr (user-selectable) External load R selectable compensation for 4, 8, 16, 75, 100, 150, 300, 600 ohm Peak hold facility.
Resolution	1 mV or 1% of reading
Indication	3 digits and bargraph
Accuracy	$\pm 3\% \pm 3 \text{ mV} \pm 1 \text{ digit}$

#### Audio Frequency Meter

Frequency Range	20 Hz to 20 kHz
Resolution	0.1 Hz at less than 10 kHz 1 Hz at 10 kHz and above
Indication	5 digits
Accuracy	As frequency standard $\pm 1 \text{ digit} \pm \text{resolution}$
Sensitivity	50 mV

#### Audio SINAD Meter

Frequency	1 kHz
Range	0 to 18 dB and 0 to 50 dB
Resolution	0.1 dB
Indication	3 digits and bargraphs
Accuracy	$\pm 1 \text{ dB}$
Sensitivity	50 mV (100 mV for 40 dB SINAD). Reading suppressed if audio voltage is less than 5 mV

#### Audio Distortion Meter

Frequency	1 kHz
Range	0 to 10 %, 0 to 30 % and 0 to 100 %
Resolution	0.1 % distortion
Indication	3 digits and bargraphs
Accuracy	$\pm 5 \%$ of reading $\pm 0.5 \%$ distortion
Sensitivity	50 mV (100 mV for 1 % distortion). Reading suppressed if audio voltage is less than 5 mV

#### Audio S/N Meter

Range	0 to 30 dB and 0 to 100 dB
Resolution	0.1 dB
Indication	3 digits and bargraph
Accuracy	$\pm 1 \text{ dB}$
Sensitivity	50 mV (100 mV for 40 dB S/N). Reading suppressed if audio voltage is less than 5 mV

## GENERAL INFORMATION

---

### Audio Oscilloscope

Operating Modes	Single with digital storage on screen or repetitive sweep
Frequency Range	DC to 50 kHz, 3 Hz to 50 kHz AC coupled
Voltage Range	10 mV to 20 V per division in a 1, 2, 5 sequence
Voltage Accuracy	$\pm 5$ % of full scale
FM Ranges	$\pm 75$ , 30, 15, 6, 3 and 1.5 kHz deviation full scale, $\pm 10$ % accuracy
AM Ranges	20, 10 and 5 % per division, $\pm 10$ % accuracy
Timebase	50 $\mu$ s/div to 5 s/div in a 1,2,5 sequence
Graticule	10 horizontal by 6 vertical divisions
Special features	Built in antialiasing circuitry and variable decode trigger level

### Audio Barcharts

Barchart Displays	AF Voltage, SINAD, Distortion, S/N
Vertical Resolution	2 % of full scale
Ranging	Autoranging, range hold or manual selection 1, 2, 5, sequence with hysteresis

### Audio and Modulation Filters

Lowpass Filters	Four independently configurable Lowpass filters LP1, LP2, LP3, LP4 that can be set to any frequency cut off point from 250 Hz to 20 000 Hz (excluding the band 1001 to 2999 Hz). 50 kHz Lowpass (no filters applied). 750 $\mu$ s de-emphasis.
Highpass Filters	50 Hz Highpass 300 Hz Highpass
Bandpass Filters	Any combination of LP1, LP2, LP3, LP4 and the Highpass filters.

### Audio Analyzer General Features

Tones mode	
------------	--

**Transmitter measurements**

**RF Frequency Meter**

Frequency Range	100 kHz to 1.05 GHz (manual tune) 10 MHz to 1 GHz (auto-tune)
Resolution	1 Hz or 10 Hz, up to 1050 MHz, selectable 0.1 Hz, 1 Hz, 10 Hz up to 999 MHz, selectable
Indication	Up to 10 digits
Accuracy	As frequency standard $\pm$ resolution
Acquisition Time	Less than 1 second (manual). Typically 3 seconds (autotune)
Sensitivity	Autotuned: 5 mW (N-Type) 0.05 mW BNC (antenna port) Manual Tuned: -34 dBm (N-Type), -60 dBm BNC (antenna port) Auto or manual control of input attenuator
VSWR	N Type <1.2:1 to 500 MHz <1.25:1 to 1.05 GHz BNC (antenna port) <3:1 to 1.05 GHz

**RF Power Meter (Broadband)**

Frequency Range	200 kHz to 1.05 GHz
Dynamic Range	5 mW to 150 W (N-Type) 0.05 mW to 250 mW BNC (antenna port)
Indication Units	W, dBm or dBW
Indication	3 digits or bargraph
Resolution	0.1 dB max, typically 1%
Accuracy (N-Type)	$\pm 10\%$ $\pm$ resolution up to 1 GHz (FM & CW)
Maximum Continuous Rating	N-Type: 50 W at 20°C (68°F) Antenna port: 1 W
Intermittent Rating	N-Type: 150 W for limited periods, typically 1 minute at 20°C (68°F). Overload indicated by audible and visual warning.

**Modulation Meter**

Sensitivity	Autotuned: 5 mW (N-Type) 0.05 mW BNC (antenna port) Manual Tuned: -34 dBm (N-Type) -60 dBm BNC (antenna port) Auto or manual control of input attenuator.
-------------	---

**Audio and Modulation Filters**

Lowpass Filters	Four independently configurable Lowpass filters LP1, LP2, LP3, LP4 that can be set to any frequency cut off point from 250 Hz to 20 000 Hz (excluding the band 1001 to 2999 Hz). 50 kHz Lowpass (No filters applied). 750 $\mu$ s de-emphasis.
Highpass Filters	50 Hz Highpass 300 Hz Highpass
Bandpass Filters	Any combination of LP1, LP2, LP3, LP4 and the Highpass filters.

**Amplitude Modulation**

Frequency Range	100 kHz to 1.05 GHz
Modulation Frequency Range	10 Hz to 15 kHz
AM Depth Range	0 to 99% (manually tuned) 0 to 90% below 100 MHz 0 to 80% from 100 to 400 MHz Peak hold facility

## GENERAL INFORMATION

---

Resolution	1% AM
Indication	2 digits and bargraph
Accuracy †	± 5% ±1 digit at 1 kHz ± 8.5% ±1 digit from 50 Hz to 10 kHz
Demodulation Distortion †	Less than 2 %, at 1 kHz & 30% AM, (CCITT Weighted)
Residual AM	Less than 1 % (300 Hz to 3.4 kHz)

### Frequency Modulation

Frequency Range	100 kHz to 1.05 GHz
Modulation Frequency Range	10 Hz to 15 kHz
Deviation Range	0 to 75 kHz
	Peak hold facility
Resolution	10 Hz below 2 kHz deviation, 1% above 2 kHz deviation
Indication	3 digits and bargraph
Accuracy †	± 5 % ±resolution at 1 kHz modulation frequency ± 7.5 % ±resolution for modulation frequencies 50 Hz to 10 kHz
Demodulation Distortion	Less than 2 % at 1 kHz and 5 kHz FM, (CCITT Weighted)
Residual FM	Less than 30 Hz (300 Hz to 3.4 kHz)
Demodulation Output Socket	200 mV peak to peak ±10 % per 1 kHz deviation

† At low modulation levels the residual AM / FM may become significant

## GENERAL INFORMATION

---

### RF spectrum analyzer

Frequency Range	100 kHz to 1.0 GHz		
Spans	Continuously variable, 1 kHz / division to 100 MHz / division. 1, 2, 5, 10 increments. Start / Stop facility allows selection of infinitely variable span width.		
Resolution Bandwidth	300 Hz, 3, 30, 300 kHz, 3 MHz		
Reference Level (top of screen)	-50 dBm to +52 dBm 0.7 mV to 71 V		
Displayed dynamic range	80 dB		
Noise floor	Typically 75 dB below top of screen		
On Screen Linearity	Typically $\pm 2$ dB $\pm$ resolution (10 dB/div) ( $>10$ dB above the noise floor)		
Vertical resolution	0.1 dB on 2 dB / division 0.5 dB on 10 dB / division		
Level Flatness	$\pm 1$ dB $\pm$ resolution over 50 MHz span		
Intermodulation Distortion	Better than 70 dB for two signals at -30 dBm into first mixer		
Sweep speeds	10 ms/div to 200 ms/div in a 1, 2, 5 sequence (optimum sweep speed and bandwidth selected according to span, or user-selectable)		
	<b>Span</b>	<b>Resolution B/W</b>	<b>Update (Sweeps/sec)</b>
	10 kHz	300 Hz	5
	100 kHz	3 kHz	9
	1 MHz	30 kHz	9
	10 MHz	300 kHz	9
	100 MHz	300 kHz	5
	1000 MHz	3 MHz	5
Marker Indication	Level and frequency or delta marker from center line of scan. Single marker for frequency and level display. Marker to center frequency. $\Delta$ marker.		
Sensitivity	2 $\mu$ V		
Tracking generator offset/frequency range	0 to 999 MHz/400 kHz to 1000 MHz		

## Audio generators

### Frequency

Frequency Range	5 Hz to 33 kHz
Setting	Keyboard entry, delta increment / decrement function and rotary control
Indication	5 digits
Resolution	0.1 Hz below 3.25 kHz 1 Hz above 3.25 kHz
Accuracy	0.01 Hz below 180 Hz 0.1 Hz above 180 Hz

### Level

Level Range	0.1 mV to 4 V RMS
Setting	Keyboard entry, delta increment / decrement function and rotary control
Indication	4 Digits
Resolution	0.1 mV below 409 mV 1 mV above 409 mV
Accuracy	±5% ±resolution 50 Hz to 15 kHz
Output impedance	Nominally 5 Ω (minimum load impedance 25 Ω)
Distortion	Less than 0.5 % at 1 kHz Less than 1 % from 50 Hz to 15 kHz

### Signaling Encoder / Decoder

Sequential Tones Functions	including revert
User Defined Tones	Encodes and decodes up to 40 tones, CCIR, ZVEI, DZVEI, EEA, EIA or user-defined. Any of the tones may be extended. Continuous, burst and single-step modes available. Up to two frequency plans may be defined and stored within the instrument for sequential tones. Any of the standard tone frequency plans may be copied to the user defined plans and modified. Tone length 20 ms to 20 s. Standard tone frequencies may be selected from a menu.
DTMF	Generation and decoding of DTMF tones.
DCS	Generation and decoding of Digitally Coded Squelch, DCS.
POCSAG	Generation of POCSAG code CCIR No. 1 Rec 584. Bit rates from 400 to 4800 bit/s. Inversion available.
Audio Monitor	Demodulated signals and audio signals may be monitored via the internal loudspeaker and via the accessory socket output on the front panel.

## Frequency standard

### Internal Frequency Standard (TCXO)

Frequency	10 MHz
Temperature stability	Better than 0.5 in 10 <sup>6</sup> , 0 to 40°C (32 to 104°F); 0.6 in 10 <sup>6</sup> , 0 to 50°C (32 to 122°F).
Ageing Rate	Better than 1 in 10 <sup>6</sup> per year
Warm up	1 minute to specified accuracy

### External Frequency Standard Input

Frequency	1, 2, 5 and 10 MHz
Input Level	Greater than 1 V peak to peak
Input Impedance	Nominally 1 kΩ

## GENERAL INFORMATION

---

### General

<b>Keyboard and Display</b>	Logical color coded keyboard with bright high resolution fast LCD	
Display size	160 x 85 mm	
<b>RS232C</b>	RS232C interface is provided for printing and remote instrument control.	
Connector	9 way male 'D' Type	
<b>Power Requirements</b>		
AC Supply Voltage	100 V to 240 V~ (Limit 90 to 264 V~)	108 V to 118 V~ (Limit 98 to 132 V~)
AC Supply Frequency	50 Hz to 60 Hz (Limit 45 to 66 Hz)	50 Hz to 400 Hz (Limit 45 to 440 Hz)
Maximum AC Power	190 VA	
DC Supply Voltage	11 to 32 V	
Maximum DC Power	100 W	
<b>Calibration Interval</b>	2 Years	
<b>Electro-Magnetic Compatibility</b>	Conforms with the protection requirements of the EEC Council Directive 89/336/EEC.  Conforms with the limits specified in the following standards: IEC/EN61326:1997 + A1 : 1998 + A2 : 2001 RF Emission Class A, Immunity Table 1, Performance Criterion A	
<b>Safety</b>	Conforms with the requirements of EEC Council Directive 73/23/EEC (as amended) and is designed to the product safety standard IEC/EN 61010-1 : 2001 + C1 : 2002 + C2 : 2003 for Class 1 portable equipment, for use in a Pollution Degree 2 environment. The instrument is designed to operate from an Installation Category 2 supply.	
<b>Environmental</b>		
Rated range of use	0°C to 50°C (32 to 122°F) and up to 95% relative humidity at 40°C (104°F)	
<b>Storage and transport</b>		
Temperature	-30°C to +70°C (-22 to +158°F)	
Altitude	Up to 2500 m (1.55 mile) (pressurized freight at 27 kPa (3.9 lb/in <sup>2</sup> ) differential)	
<b>Dimensions and Weight</b>		
Standard dimensions		
Height	185 mm (7.3 inches)	
Width	400 mm (15.7 inches)	
Depth	460 mm (18.1 inches) (including handle, feet and covers)	
Option 30 dimensions		
Height	185 mm (7.3 inches)	
Width	420 mm (16.5 inches)	
Depth	565 mm (22.2 inches) (including handle, feet and covers)	
Weight	Typically less than 11.4 kg, (less than 25 lb)  10.5 kg (23 lb), (no options), less than 13 kg (29 lb) (fully equipped)	

## Options and accessories

### Options

Option 1	600 $\Omega$ Matching Unit
Option 3	High Stability OCXO
Option 4	Parallel Interface
Option 5	GPIB Interface
Option 8	SSB Demodulator
Option 23	CCITT Filter
Option 24	CMESS Filter
Option 27	Look and Listen addition to Spectrum Analyzer
Option 30	Bail arm and front panel stowage cover
Option 32	Internal Battery

### 600 $\Omega$ Matching Unit (Option 1)

Features	Switchable 600 $\Omega$ balanced AF input and output Switchable 20 dB attenuator on AF generator output †
----------	--

#### Input circuit

Impedance:	600 $\Omega$
Return loss:	>21 dB at 1 kHz
Frequency response:	$\pm 0.5$ dB at 200 Hz to 5 kHz, $\pm 2$ dB at 100 Hz to 20 kHz
Accuracy of 1:1 input:output ratio:	$\pm 1\%$ at 1 kHz $\pm$ accuracy of 2944B
Maximum input:	5 V RMS maximum at 200 Hz to 5 kHz, 3 V RMS maximum at 100 Hz to 20 kHz

#### Output circuit

Impedance:	600 $\Omega$
Return loss:	>21 dB at 1 kHz
Frequency response:	$\pm 0.5$ dB at 200 Hz to 5 kHz, $\pm 2$ dB at 100 Hz to 20 kHz
Level accuracy:	$\pm 2\%$ at 1 kHz $\pm$ accuracy of 2944B
Output level:	1 mV to 2.5 V RMS across 600 $\Omega$ .

† The 20 dB attenuator facility reduces the AF output resolution to 0.01 mV up to 40 mV output level.  
The accuracy of the output level degrades by  $\pm 2\%$

### High Stability Internal Frequency (OCXO) Standard (Option 3)

Frequency	10 MHz
Temperature Stability	Better than 5 part in $10^8$ , 5 to 55°C (41 to 131°F)
Ageing Rate	Better than 1 part in $10^7$ per year, after 1 month continuous use.
Warm-up Time	Less than 10 minutes to within 2 parts in $10^7$ at 20°C (68°F).

### Parallel Interface (Option 4)

	Allows direct connection of a parallel printer. Additionally provides 4 software programmable output lines.
Printer port	
Connector	25 way female D-type.
Printers supported	75,100,150 dots per inch laser printers FX80, FX100 Epson format.
Accessory port	
Connector	9 way female D-type.
Outputs	4 independently programmable output lines, each one configurable as a logic line or as a relay contact closure. +5 V supply available.



## GENERAL INFORMATION

---

<b>GPIB (Option 5)</b>	For printing, remote instrument control or for programming of user-defined test sequences.
Capability	Complies with the following subsets defined by IEEE488: SH1, AH1, T6, L4, SR1, RL1, E1, DC1, DT0
<b>SSB Demodulator (Option 8)</b>	The SSB demodulator allows signals to be demodulated either via the internal loudspeaker or via the accessory socket. Provides demodulation of SSB signals (upper and lower sideband.)
Modulation Meter	
Frequency range	400 kHz to 1 GHz
AF demodulation range	10 Hz to 15 kHz
Distortion	Typically less than 3% at 1 kHz (300 Hz to 3.4 kHz)
Detection range	2 $\mu$ V to 150 W
Features	Automatic detection of USB or LSB. BFO can be used for tuning of carrier for AM and FM radios.
<b>CCITT Filter (Option 23)</b>	Allows a CCITT filter to be inserted into either the demodulated audio path or the audio input path.
<b>CMESS Filter (Option 24)</b>	Allows a CMESS filter to be inserted into either the demodulated audio path or the audio input path.
<b>Look and Listen (Option 27)</b>	Provides simultaneous spectrum display and demodulation of the center frequency for span widths of 100 kHz, 200 kHz, 500 kHz and 1 MHz. Sensitivity 2 $\mu$ V.
<b>Bail arm and front panel stowage cover (Option 30)</b>	Provides a bail arm carrying handle and front panel cover and storage area. The bail arm will also provide additional viewing angles when mounted on a bench.
<b>Internal Battery (Option 32)</b>	
Type	12 V Ni-mH
Normal capacity when new	Typically 60 minutes instrument operation
Weight	1.8 kg (4 lb)
Charge time from instrument	4 hrs
Temperature range	5–35°C (41 to 95°F) charge; 0–50°C (32 to 122°F) discharge
<b>Supplied Accessories</b>	AC Supply lead † 43138/755      DC Supply lead 46882/744      Operating Manual 46882/683      Programming Manual
	† The AC supply lead provided with the Service Monitor will depend on the destination country. See Power requirements, Power cords, in Chapter 2 of this manual

## GENERAL INFORMATION

---

### Optional Accessories

44991/145	Microphone with PTT
54431/023	20 dB AF attenuator (BNC)
46884/728	Rack Mounting Kit
54421/001	Antenna BNC
46662/779	Soft carrying case (suitable for all 294x except early units being used with external battery)
46662/571	Soft carrying/operational case
46662/616	Soft carrying/operational case for use with Option 30
46880/118	Service Manual (consists of Operating Manual plus Maintenance Manual)
46884/648	Serial cable 9 way female to 25 way male
46884/649	Serial cable 9 way female to 25 way female
46884/650	Serial cable 9 way female to 9 way female

---

# Chapter 2 INSTALLATION

## Contents

Introduction.....	2-2
Initial visual inspection of new instruments.....	2-2
Ventilation .....	2-2
Operational case (46662/571) shoulder strap.....	2-3
Bail arm option .....	2-3
Power requirements .....	2-3
Fuses .....	2-3
Class I power cords (3-core).....	2-4
Connecting to a DC supply and fitting batteries .....	2-6
RF and AF connections.....	2-6
Accessory socket connections.....	2-7
Remote control connections.....	2-9
RS232 .....	2-9
GPIB .....	2-10
Self tests and acceptance tests.....	2-11
Self tests.....	2-11
Using the Service Monitor .....	2-12
Routine maintenance.....	2-13
Ventilation fan and filter.....	2-13
Routine safety testing and inspection.....	2-14
1. Visual inspection .....	2-14
2. Earth bonding tests .....	2-14
3. Insulation tests .....	2-15
4. Rectification.....	2-15
Cleaning.....	2-15

## List of tables

Table 2-1 Accessory socket pin numbering, location and functions.....	2-7
Table 2-2 Accessory socket logic and applications .....	2-8

## List of figures

Fig. 2-1 Preventing strap buckle from slipping.....	2-3
Fig. 2-2 Accessory in/out socket pin numbers.....	2-7
Fig. 2-3 RS232 serial port connections.....	2-9
Fig. 2-4 Null modem connections.....	2-9
Fig. 2-5 IEEE488 parallel port connections.....	2-10

### Introduction

This chapter deals with preparing the Service Monitor for use for the first time and with the checks to be made when the Service Monitor may have been used under unknown conditions.

The latter situation could well apply where the Service Monitor is used by several users for differing tasks.

### Initial visual inspection of new instruments

After unpacking the Service Monitor and before making any connections to a power source, inspect for any signs of mechanical damage.

### Ventilation

The Service Monitor is force cooled by a fan located in the rear panel. The cooling air is drawn into the Service Monitor through the fan and expelled through ventilator grills located on the right and on the underside. An air filter over the fan inlet prevents the ingress of dust and other particles.

#### CAUTION

**The Service Monitor requires an unrestricted airflow to ensure that its performance meets the specification. Before switching the Service Monitor on, check that the air inlet on the rear panel is not restricted and that there is no loose material close by which could be sucked into the fan. Refer to *Routine Maintenance* later in this chapter for details of cleaning and replacing the air filter.**

**The optional operational case has ventilation apertures which align with those of the Service Monitor. Ensure that these are not obstructed.**

## Operational case (46662/571) shoulder strap

The shoulder strap supplied with the operational case should be attached to the front handles of the Service Monitor. When fitting the strap, always loop the tails of the strap through the buckles in the reverse direction. This will prevent the strap from slipping through the buckle. See *Fig. 2-1, Preventing strap buckle from slipping.*

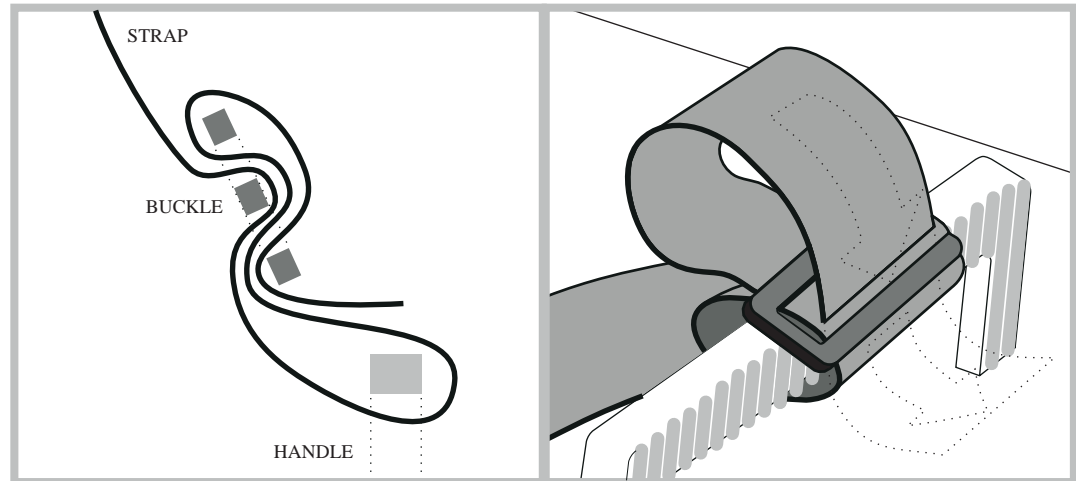

*Fig. 2-1 Preventing strap buckle from slipping.*

### Bail arm option

If the bail arm carrying handle is fitted, the Service Monitor will not fit into the optional Operational Case, 46662/571. Do not attempt to attach the shoulder strap supplied with this case to a Service Monitor fitted with a bail arm carrying handle.

Soft carrying/operational case part number 46662/616 is designed for use with a Service Monitor fitted with a bail arm carrying handle.

## Power requirements

The Service Monitor can be powered from a wide range of power sources, both AC and DC.

AC supplies must be within the range 100 V to 240 V, at a frequency of between 50 Hz and 60 Hz; or within the range 108 V to 118 V, at a frequency of between 50 Hz and 400 Hz

The maximum power consumption is 190 VA

Voltage selection is not necessary as the AC power supply module within the Service Monitor is designed to handle this wide spread of input variations.

For DC operation, the Service Monitor requires a supply within the range 11 V to 32 V. The maximum DC power requirement is 100 W.

## Fuses

The AC input circuit is fed through a single fuse fitted to the rear panel of the Service Monitor, within the AC input connector. This should be a T2AL250V fuse.

The DC input circuit is also fed through a single fuse. This is fitted within the fuseholder adjacent to the DC input connector. This should be a T10AH250V fuse.

## Class I power cords (3-core)

### Disconnecting device

The detachable power cord is the instrument's disconnecting device, but if the instrument is integrated into a rack or system, an external power switch or circuit breaker may be required. Whatever the disconnecting device, make sure that you can reach it easily and that it is accessible at all times.

### General

The instrument is a Safety Class 1 product and therefore must be earthed. Use the supplied power cord or an appropriate replacement. Make sure that the instrument is plugged into an outlet socket with a protective earth contact.

When the equipment has to be plugged into a Class II (ungrounded) 2-terminal socket outlet, the cable should either be fitted with a 3-pin Class I plug and used in conjunction with an adapter incorporating a ground wire, or be fitted with a Class II plug with an integral ground wire. The ground wire must be securely fastened to ground. Grounding one terminal on a 2-terminal socket will not provide adequate protection.

In the event that a molded plug has to be removed from a lead, it must be disposed of immediately. A plug with bare flexible cords is hazardous if engaged in a live socket outlet.

Power cords with the following terminations are available from Aeroflex Ltd. Please check with your local sales office for availability.

This equipment is provided with a 3-wire (grounded) cordset which includes a molded IEC 60320-1 connector for connection to the equipment. The cable must be fitted with an approved plug which, when plugged into an appropriate 3-terminal socket outlet, grounds the case of the equipment. Failure to ground the equipment may expose the operator to hazardous voltage levels. Depending upon the destination country, the color coding of the wires will differ:-

### British

Country	IEC 60320-1 plug	Aeroflex part number
United Kingdom	Straight through	23422/001
United Kingdom	Right angled	23422/002

The UK lead is fitted with an ASTA approved molded plug to BS 1363.

A replaceable 13 A fuse to BS 1362 is contained within the plug. This fuse is only designed to protect the lead assembly. Never use the plug with the detachable fuse cover omitted or if the cover is damaged.

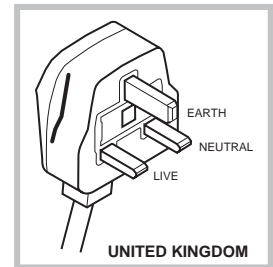

C3510

The fuse(s) or circuit breaker to protect the equipment is fitted at the back of the equipment.

### North American

Country	IEC 60320-1 plug	Aeroflex part number
North American	Straight through	23422/004
North American	Right angled	23422/005

The North American lead is fitted with a NEMA 5-15P (Canadian CS22.2 No 42) plug and carries approvals from UL and CSA for use in the USA and Canada.

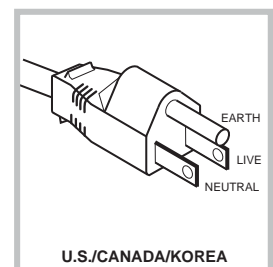

C3511

## Continental Europe

Country	IEC 60320-1 plug	Aeroflex part number
Europe	Straight through	23422/006
Europe	Right angled	23422/007

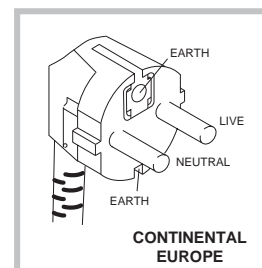

C3512

The Continental European lead is fitted with a right angle IEC83 standard C4 plug (CEE 7/7) which allows it to be used in sockets with either a male earth pin (standard C 3b) or side earth clips (standard C 2b) the latter is commonly called the German 'Schuko' plug. In common with other Schuko style plugs, the plug is not polarized when fitted into a Schuko socket. The lead carries approvals for use in Austria, Belgium, Finland, France, Germany, Holland, Italy, Norway and Sweden. Note that this plug will not fit Italian standard CEI 23-16 outlets. The lead should not be used in Denmark given that the earth connection will not be made.

## Français

Le câble d'alimentation d'Europe Continentale est muni d'un connecteur mâle à angle droit type CEI83, standard C4 (CEE 7/7), qui peut être utilisé dans une prise femelle à ergot de terre (standard C 3b) ou à clips latéraux (standard C 2b), cette dernière étant communément appelée prise "Schuko" allemande. De la même façon que les autres connecteurs de type Schuko, celui-ci n'est pas polarisé lorsqu'il s'adapte à une prise femelle Schuko. Ce câble d'alimentation est homologué en Allemagne, Autriche, Belgique, Finlande, France, Hollande, Italie, Norvège et Suède. À noter que ce connecteur n'est pas compatible avec les prises de courant italiennes au standard CEI 23-16. Ce câble ne doit pas être utilisé au Danemark à cause du défaut de connexion de masse.

## Deutsch

Das kontinentaleuropäische Netzkabel ist mit einem rechtwinkligen Stecker nach IEC83 C4 (CEE7/7) Standard versehen, welcher sowohl in Steckdosen mit Erde-Stift (Standard C 3b) oder seitlichen Erdeklemmen, im allgemeinen "Schukosteckdose" genannt, paßt. Üblicherweise ist der Schukostecker bei Verwendung in Schukosteckdosen nicht gepolt. Dieses Netzkabel besitzt Zulassung für Österreich, Belgien, Finnland, Frankreich, Deutschland, Holland, Italien, Norwegen und Schweden.

Hinweis: Dieser Schukostecker paßt nicht in die italienischen Standardsteckdosen nach CEI 23-16 Norm. Dieses Netzkabel sollte nicht in Dänemark verwendet werden, da hier keine Erdeverbindung hergestellt wird.

## Español

El cable de alimentación tipo Europeo Continental dispone de una clavija C4 normalizada IEC83 (CEE 7/7) que permite su utilización tanto en bases de enchufe con toma de tierra macho (tipo C 3b) o con toma de tierra mediante contactos laterales (tipo C 2b) que, en este último caso, suele denominarse "Schuko". Al igual que cualquier otra clavija tipo Schuko, las conexiones a red no están polarizadas cuando se conectan a una base tipo Schuko. El cable lleva autorización para su uso en Austria, Bélgica, Finlandia, Francia, Alemania, Holanda, Italia, Noruega y Suecia. Observe que este cable no se adapta a la norma italiana CEI 23-16. El cable no debe utilizarse en Dinamarca en el caso de no efectuarse conexión a tierra.

## Italiano

I cavi d'alimentazione per l'Europa continentale vengono forniti terminati con una spina ad angolo retto del tipo C4 secondo lo standard IEC83 (CEE 7/7) che può essere usato in prese in cui la terra può essere fornita o tramite connettore maschio (C 3b) o tramite clips laterali (C 2b), quest'ultima comunemente detta di tipo tedesca "Schuko". Questa spina, quando collegata ad una presa Schuko, non è polarizzata.

Il cavo può essere usato in Austria, Belgio, Finlandia, Francia, Germania, Olanda, Norvegia, Svezia ed Italia. E' da notare che per l'Italia questo non risponde allo standard CEI 23-16.

Questa spina non dovrebbe invece essere usata in Danimarca in quanto non realizza il collegamento di terra.

### Connecting to a DC supply and fitting batteries

If the Service Monitor is to be used from a DC voltage source it should be connected using the supplied DC connecting lead, part no. 43138/755. The polarity of the connections must be correct, RED to POSITIVE, BLACK to NEGATIVE, and the DC input voltage selector set to the appropriate range for the supply.

The negative connection of the DC supply is directly connected to the chassis of the Service Monitor and therefore to all screen connections of input and output connectors. Note however, that the AF ports are isolated under some operating conditions.

The Service Monitor will function from any supply with a voltage within the range given under [Power requirements](#) above, but must be capable of delivering a current in the order of 9 amps at the lowest voltage.

Ensure that the supply lead connections are sound and cannot short together.

If the Test Set has been supplied with a battery pack, this will have been fitted before shipping.

The battery pack should not require any attention over its expected life. If you do suspect a problem with the battery pack contact the nearest Aeroflex [regional office](#).

A fully charged battery pack will power the Service Monitor for approximately 60 minutes between charges. The Service Monitor will recharge the battery in approximately 4 hours if connected to a mains supply and the mains power switch put to the 'CHARGE' position.

Use only the battery pack specified by Aeroflex.

### RF and AF connections

All RF and AF connections should be made using good quality connectors correctly fitted to appropriate cable. All connectors should be locked to the Service Monitor using the bayonet or threaded locking rings. Do not use leads that have damaged connectors or cable as this can cause poor performance and might damage the Service Monitor.

RF leakage levels in a test set-up can be aggravated by the use of poor quality connector leads. A double screened lead, 1 meter in length and terminated with male BNC connectors, part no. 43137/052 and a 1 meter, 'N type' male to 'N type' male, connector lead 54311/095 are both available from Aeroflex sales offices.

#### **WARNING**

### Hot Surfaces

Take care when touching the RF Input Type N connector after the application of high levels of continuous power. If 50 W is exceeded for a prolonged period, the temperature of the connector can become excessive.



## Accessory socket connections

The accessory socket located on the front panel, is of the 7 pin DIN, 45° configuration. The function of each of the pins on this socket is shown in the following table. The pin numbering is shown in *Fig. 2-2 Accessory in/out socket pin numbers*, and is as viewed from the front of the Service Monitor.

**Table 2-1 Accessory socket pin numbering, location and functions.**

Din pin No	Function
6	Logic
1	Mic input/PTT-logic
4	Forward power
2	12 V DC at approx 100 mA
5	Reverse power
3	Logic
7	Loudspeaker output

The pin numbering of the Accessory socket, as seen from the front of the Service Monitor, is shown in *Fig. 2-2 Accessory in/out socket pin numbers*.

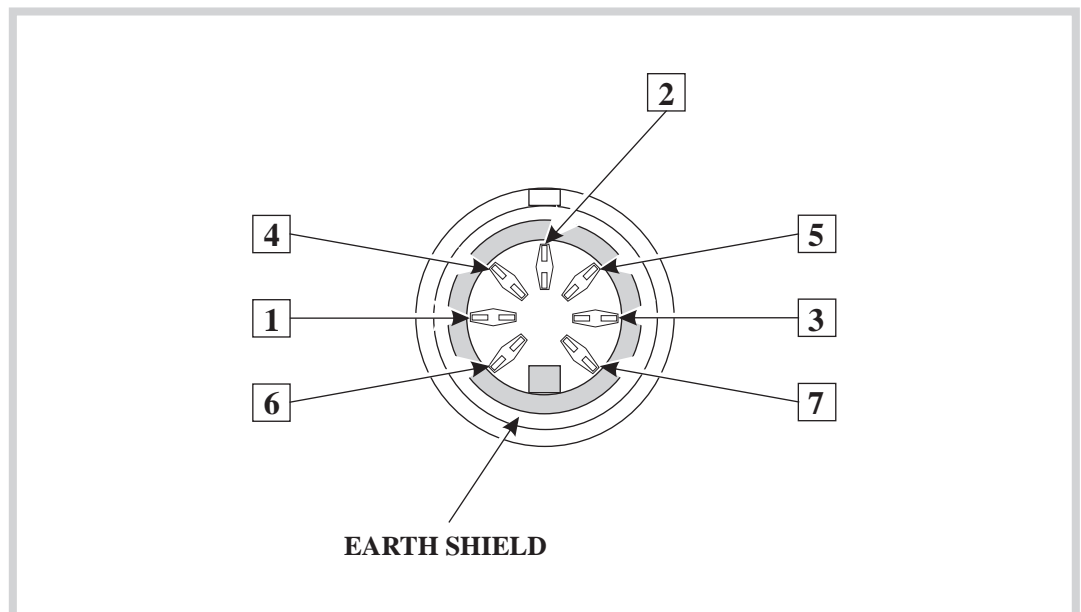

C1785

*Fig. 2-2 Accessory in/out socket pin numbers*

The socket is used for connecting dedicated accessories such as microphones with press to talk switching capabilities.

Selection logic [or data signals] on pins 1,3 and 6 enables the Service Monitor to recognize the connections of an external accessory. The appropriate pins are at TTL levels and are active low (L) as shown below:

## INSTALLATION

---

**Table 2-2 Accessory socket logic and applications**

<b>Accessory</b>	<b>Pin 1</b>	<b>Pin 3</b>	<b>Pin 6</b>
Nothing connected	High	High	High
Microphone (press to talk)	Low	High	High
External power: Auto zero	High	Low	Low
External power: Peak power	High	High	Low
External power: CW power	High	Low	High

Refer to Chapter 3, *Operation*, for details of using the socket.,

A 3.0 m lead assembly (part no. 43130/591) is available as an optional accessory.

## Remote control connections

### RS232

The serial port connection requires a 9 way female 'D' Type connector. This should be correctly fitted to appropriate cable and the locking screws should be used to prevent undue strain from being applied to the connector housing.

The pin connections are listed below and the pin locations shown in *Fig. 2-3 RS232 serial port connections (as seen facing panel)*.

Contact	Function	Contact	Function
1	Not connected	6	DSR
2	Rx data in	7	RTS
3	Tx data out	8	CTS
4	DTR	9	Not connected
5	Ground		

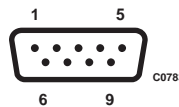

*Fig. 2-3 RS232 serial port connections (as seen facing panel)*

The use of a NULL MODEM cable assembly is required for connecting to control equipment such as PCs.

The connections for 9 way to 9 way and 9 way to 25 way versions is shown in *Fig. 2-4*.

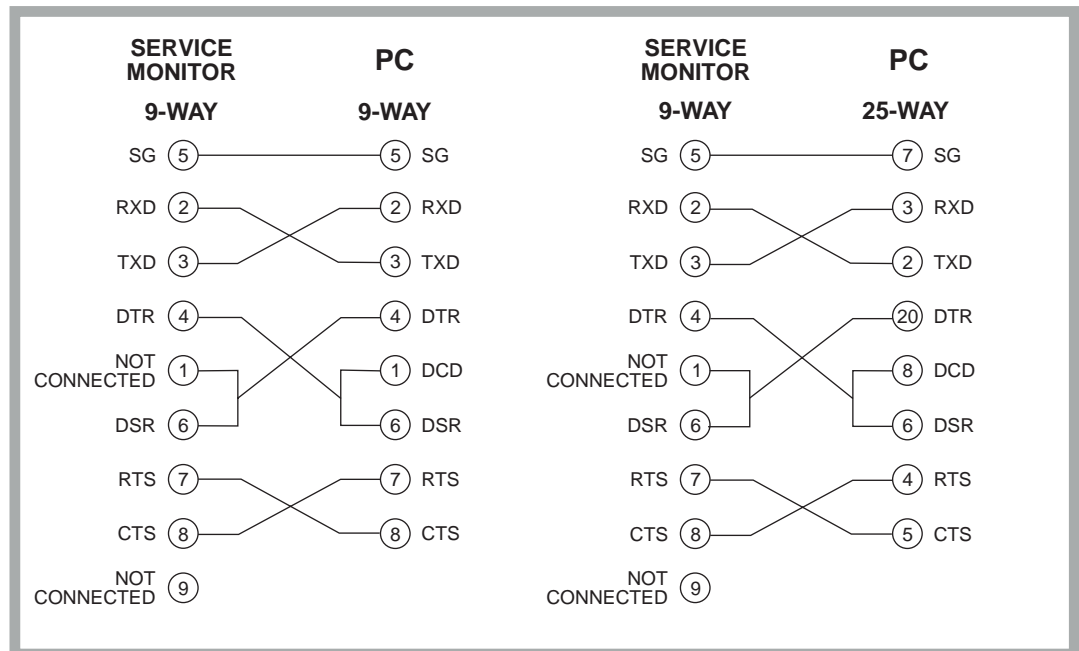

C3383

*Fig. 2-4 Null modem connections*

## INSTALLATION

### GPIB

When the optional GPIB interface unit has been fitted, connections are made to it using a 24-way IEEE 488 male connector. If a stackable connector is used in order to interconnect more than two pieces of equipment, ensure that no physical damage to the Service Monitor connector will result.

The pin connections are listed below and the pin locations shown in *Fig. 2-5 IEEE488 parallel port connections (as seen facing panel)*.

Contact	Function	Contact	Function
1	Data I/O 1	13	Data I/O 5
2	Data I/O 2	14	Data I/O 6
3	Data I/O 3	15	Data I/O 7
4	Data I/O 4	16	Data I/O 8
5	EOI	17	REN
6	DAV	18	Pair with 6
7	NRFD	19	Pair with 7
8	NDAC	20	Pair with 8
9	IFC	21	Pair with 9
10	SRQ	22	Pair with 10
11	ATN	23	Pair with 11
12	Ground shield	24	Logic ground

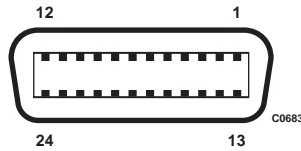

*Fig. 2-5 IEEE488 parallel port connections (as seen facing panel)*

## Self tests and acceptance tests

The service monitor incorporates a self test program which allows users to verify its condition at any time. This program is described below.

When it is necessary to prove that the performance of the Service Monitor meets the published performance data, the *Acceptance tests*, described in Chapter 5, should be carried out.

### Self tests

The built in Self Test program measures the output parameters of the RF generator using the transmitter test functions. The RF generator output is coupled internally and no external connections are required.

The self test program is accessed through the help/set-up menu and comprises 17 tests, which are listed on the display when the *[Self Test]* key is pressed.

Before running the program, the Service Monitor should be reset to the factory preset state. This is done by pressing the [MEM] key, to display the STORE/RECALL screen and menu. The message 'Recall Store No ' is shown. key in and enter the digits '01'. The Service Monitor will now be ready to run the self test program.

To run the program the *[GO]* key is pressed and the tests are carried out consecutively. The legend 'ACTIVE' is displayed against each test as it is carried out, which changes to 'PASS' or 'FAIL' as each test is completed. If a particular test fails, the reason is given alongside the 'FAIL' legend, together with the measurement.

The tests carried out, the related set-ups and the functions verified are listed below.

<b>Test No. 1</b>	Broadband power. 500 MHz
<b>Test No. 2</b>	Transmitter Frequency. 500 MHz
<b>Test No. 3</b>	Broadband power. 1 GHz
<b>Test No. 4</b>	Transmitter Frequency. 1 GHz
<b>Test No. 5</b>	Broadband power. 10 MHz
<b>Test No. 6</b>	Transmitter Frequency. 10 MHz

The above tests compare the generated power and frequency against the broadband power meter and the frequency meter at each of the frequencies specified.

Related set-up. Manual tune

The functions verified by the above tests are:

Signal generator frequency and level accuracy.

Power meter accuracy.

### Test No. 7 to 14

Narrow band power meter. Power level +10 dBm. (Test No. 7) to -60 dBm. (Test No. 14)

These tests compare the generated power levels against the narrowband power meter readings.

Related set-ups. Frequency, 10 MHz, IF Bandwidth, 30 kHz.

The functions verified by the above tests are:

Signal generator level accuracy.

Signal generator attenuators.

Spectrum analyzer level accuracy.

Receiver attenuators.

**Test No. 15** FM deviation. 50 kHz

This test checks the signal generator FM deviation against the modulation meter reading.

Related set-ups. Frequency 10 MHz, level -26 dBm, IF bandwidth 300 kHz, audio bandwidth 0.3 to 3.4 kHz, FM demodulation.

The functions verified by the above tests are:

Signal generator FM accuracy, modulation meter FM accuracy, modulation generator (audio generator) level accuracy

**Test No. 16** Modulation frequency. 1 kHz.

This test checks the modulation generator output frequency against the audio counter reading.

Related set-ups. Related set-ups. Frequency 10 MHz, level -26 dBm, IF bandwidth 300 kHz, audio bandwidth 0.3 to 3.4 kHz, FM demodulation.

The functions verified by the above tests are:-

modulation generator (audio generator) frequency accuracy

**Test No. 17** AM Depth. 50%

This test checks the signal generator AM against the modulation meter reading.

Related set-ups. Frequency 10 MHz, level -26 dBm, IF bandwidth 0.3 to 3.4 kHz, AM demodulation.

The functions verified by the above tests are:

Signal generator AM accuracy, modulation meter AM accuracy, audio generator frequency accuracy, audio generator level accuracy, audio filters, audio counter.

## Using the Service Monitor

The monitor can be used as a bench instrument, either flat standing or inclined using the elevating front feet. The monitor can also be used as a field service instrument while left in the operational case. It can be operated in any position convenient to the operator. See the **Caution** under *Ventilation*, earlier in this chapter.

Note: if the Service Monitor is supplied with the non-operational soft carrying case that has no ventilation apertures, then the Service Monitor must be removed from the case before operating.

## Routine maintenance

### Ventilation fan and filter

The ventilator fan on the rear of the Service Monitor is fitted with a filter to prevent the ingress of foreign matter into it. This should be inspected and cleaned at regular intervals. The procedure for this is as follows:

Disconnect the Service Monitor from the mains supply and from any DC supply.

Remove any other connections to the Service Monitor.

#### **WARNING**

**Failing to disconnect the power source before removing the filter could result in the fan becoming switched on accidentally.**

Stand the Service Monitor face down on a firm, non-scratch flat surface so that it is supported on the front handles.† The rear of the Service Monitor, with the fan housing, should be at a safe and accessible working height.

Remove the two M4 screws holding the fan filter to the rear of the Service Monitor and lift the filter away.

Take the filter to a suitably ventilated location and remove as much dust and other foreign matter as is practical. Do not wet or wash the filter.

Refit the filter to the Service Monitor, using the reverse procedure as appropriate.

If the filter is damaged or blocked, a replacement is available as part no. 35907/675.

† If the bail arm carrying handle has been fitted, this should be positioned over the top of the Service Monitor before standing the instrument face down, supported on the front bumpers.

### Routine safety testing and inspection

In the UK the 'Electricity at Work Regulations' (1989) section 4(2) places a requirement on the users of equipment to maintain it in a safe condition. The explanatory notes call for regular inspections and tests together with a need to keep records.

The following electrical tests and inspection information is provided for guidance purposes and involves the use of voltages and currents that can cause injury. It is important that these tests are only performed by competent personnel.

Prior to carrying out any inspection and tests the Service Monitor must be disconnected from the mains supply and all external signal connections removed. All tests should include the Service Monitor's own supply lead, all covers must be fitted and the supply switch must be in the 'ON' position.

The recommended inspection and tests fall into three categories and should be carried out in the following sequence:

1. Visual inspection
2. Earth Bonding Test (Class I equipment only)
3. Insulation Resistance test.

#### 1. Visual inspection

A visual inspection should be carried out on a periodic basis. This interval is dependent on the operating environment, maintenance and use, and should be assessed in accordance with guidelines issued by the Health and Safety Executive (HSE). As a guide, this Service Monitor, when used indoors in a relatively clean environment, would be classified as 'low risk' equipment and hence should be subject to safety inspections on an annual basis. If the use of the equipment is contrary to the conditions specified, you should review the safety re-test interval.

As a guide, the visual inspection should include the following where appropriate:

Check that the equipment has been installed in accordance with the instructions provided (e.g. that ventilation is adequate, supply isolators are accessible, supply wiring is adequate and properly routed).

The condition of the mains supply lead and supply connector(s).

Check that the mains supply switch isolates the Service Monitor from the supply.

The correct rating and type of supply fuses.

Security and condition of covers and handles.

Check the supply indicator functions (if fitted).

Check the presence and condition of all warning labels and markings and supplied safety information.

Check the wiring in re-wireable plugs and appliance connectors.

If any defect is noted this should be rectified before proceeding with the following electrical tests.

#### 2. Earth bonding tests

Earth bonding tests should be carried out using a 25 A (12 V maximum open circuit voltage) DC source. Tests should be limited to a maximum duration of 5 seconds and have a pass limit of 0.1  $\Omega$  after allowing for the resistance of the supply lead. Exceeding the test duration can cause damage to the equipment. The tests should be carried out between the supply earth and exposed case metalwork, no attempt should be made to perform the tests on functional earths (e.g. signal carrying connector shells or screen connections) as this will result in damage to the equipment.



### 3. Insulation tests

A 500 V DC test should be applied between the protective earth connection and combined live and neutral supply connections with the equipment supply switch in the 'on' position. It is advisable to make the live/neutral link on the appliance tester or its connector to avoid the possibility of returning the Service Monitor to the user with the live and neutral poles linked with an ad-hoc strap. The test voltage should be applied for five seconds before taking the measurement.

Aeroflex Ltd employs reinforced insulation in the construction of its products and hence a minimum pass limit of 7 M $\Omega$  should be achieved during this test.

Where a DC power adapter is provided with the Service Monitor the adapter must pass the 7 M $\Omega$  test limit.

We do not recommend dielectric flash testing during routine safety tests. Most portable appliance testers use AC for the dielectric strength test which can cause damage to the supply input filter capacitors.

### 4. Rectification

It is recommended that the results from the above tests are recorded and checked during each repeat test. Significant differences between the previous readings and measured values should be investigated.

If any failure is detected during the above visual inspection or tests, the Service Monitor should be disabled and the fault should be rectified by an experienced Service Engineer who is familiar with the hazards involved in carrying out such repairs.

Safety critical components should only be replaced with equivalent parts, using techniques and procedures recommended by Aeroflex Ltd.

The above information is provided for guidance only. Aeroflex Ltd designs and constructs its products in accordance with International Safety Standards such that in normal use they represent no hazard to the operator. Aeroflex Ltd reserves the right to amend the above information in the course of continuing its commitment to product safety.

### Cleaning

Before commencing any cleaning, switch off the Service Monitor and disconnect it from the supply. The exterior surface of the case may be cleaned using a soft cloth moistened in water. Do not use aerosol or liquid solvent cleaners.

---

## Chapter 3

# LOCAL OPERATION

### Contents

About this chapter .....	3-3
Front panel layout .....	3-4
Rear panel controls and connectors .....	3-8
Getting started .....	3-9
(Applying power and selecting test modes) .....	3-9
Test mode screens and menus .....	3-10
HELP/SETUP .....	3-11
Bar charts .....	3-19
Spectrum analyzer .....	3-19
Oscilloscope .....	3-19
<b>Using the test modes.....</b>	<b>3-21</b>
Brief descriptions .....	3-21
Tx test (transmitter testing) .....	3-23
Overview .....	3-23
Connections .....	3-24
Setting up .....	3-25
Making measurements .....	3-32
External attenuators .....	3-33
Rx test (receiver testing) .....	3-38
Overview .....	3-38
Connections .....	3-39
Setting up .....	3-40
AF input level measurement .....	3-44
Making measurements .....	3-47
Dx test (duplex testing) .....	3-53
Overview .....	3-53
Spectrum analyzer .....	3-55
Overview .....	3-56
Setting up .....	3-56
AF test (audio frequency testing) .....	3-63
Overview .....	3-63
Setting up .....	3-64
Input level measurement .....	3-64
Input filtering .....	3-64
Distortion measurement .....	3-65
Incremental adjustment keys .....	3-67
General .....	3-67
Assigning .....	3-68
Use within spectrum analyzer mode .....	3-68
Tones .....	3-69
Tones sub-mode .....	3-69
Observing tones signals in other test modes .....	3-69
Signal routing .....	3-70
RF input attenuators .....	3-70
Sequential tones .....	3-71
Overview .....	3-71
Testing sequential tone receivers .....	3-71
Testing sequential tone transmitters .....	3-74
CTCSS .....	3-76
Output level .....	3-76
Tone selection .....	3-76
Tone frequency shift .....	3-76

## LOCAL OPERATION

---

DCS.....	3-78
Overview.....	3-78
DCS receiver decoder testing .....	3-79
DCS transmitter encoder testing .....	3-80
DTMF .....	3-81
Overview.....	3-81
Tx test DTMF tones function.....	3-81
Rx test DTMF tones function .....	3-82
Dx test DTMF tones function .....	3-83
AF test DTMF tones function .....	3-83
POCSAG.....	3-85
Overview.....	3-85
Testing a radio pager .....	3-87
Oscilloscope.....	3-88
Setting up .....	3-88
Expanded display .....	3-89
Stores, settings/results.....	3-90
Overview.....	3-90
STORE/RECALL .....	3-90
Storing .....	3-91
DISPLAY HOLD STORE.....	3-91
Other memory functions .....	3-91
Titling store locations .....	3-92
Error messages.....	3-92
Printer.....	3-93
Parallel printer port option .....	3-93

### List of tables

Table 3-1 Parallel printer port connections .....	3-93
Table 3-2 Rear accessory port connections.....	3-95

## List of figures

Fig. 3-1 Front panel.....	3-4
Fig. 3-2 Typical displays.....	3-5
Fig. 3-3 Rear panel layout, (with optional GPIB fitted).....	3-8
Fig. 3-4 AF Filter HELP/SETUP page.....	3-12
Fig. 3-5 Relationship of measurement and number of samples.....	3-18
Fig. 3-6 Transmitter test connections.....	3-24
Fig. 3-7 Distortion level and signal to noise level measurements.....	3-36
Fig. 3-8 Receiver test connections.....	3-39
Fig. 3-9 Selectivity test setup.....	3-50
Fig. 3-10 Spurious response 'Image Frequency' location.....	3-51
Fig. 3-11 One port duplex test setup.....	3-53
Fig. 3-12 Alternative two port duplex setups.....	3-54
Fig. 3-13 Spectrum analyzer test setup.....	3-55
Fig. 3-14 Spectrum analyzer test setup using the tracking generator.....	3-55
Fig. 3-15 Spectrum Analyzer setup, Look and Listen function.....	3-60
Fig. 3-16 Audio test setup.....	3-63
Fig. 3-17 Tones selection screen and Tones mode receiver input level setting.....	3-69
Fig. 3-18 RF Sequential tones encoder display, main menu.....	3-72
Fig. 3-19 RF Sequential tones standard selection menu.....	3-72
Fig. 3-20 RF Sequential tones decoder screen.....	3-74
Fig. 3-21 RF CTCSS encoder screen and menu.....	3-76
Fig. 3-22 RF DCS ENCODER screen and menu.....	3-79
Fig. 3-23 RF DTMF DECODER screen and menu.....	3-81
Fig. 3-24 POCSAG radio pager test screen and menu.....	3-85
Fig. 3-25 Alternative address/warning messages.....	3-86
Fig. 3-26 Parallel printer port socket contacts.....	3-93
Fig. 3-27 Simplified diagram of rear accessory port switching.....	3-94
Fig. 3-28 Rear accessory port socket connections.....	3-94

## About this chapter

This chapter deals with using the Communications Service Monitor as a 'stand alone' instrument.

The front panel layout is described and a brief explanation of all controls and connections is given.

The connectors and occasional controls on the rear panel are identified.

An introduction to each of the test modes explains the principles behind tests that can be carried out and suggests some applications for the use of the monitor.

The power up and setup procedures are explained.

The operating sequences for each of the test modes is explained and the relevant menus outlined.

The internal setup and results memories are described and their use explained.

Producing hard copy of results on an external printer is described.

Before using the instrument, familiarize yourself with the power requirements and powering up procedure described in Chapter 2, *Installation*.

Front panel layout

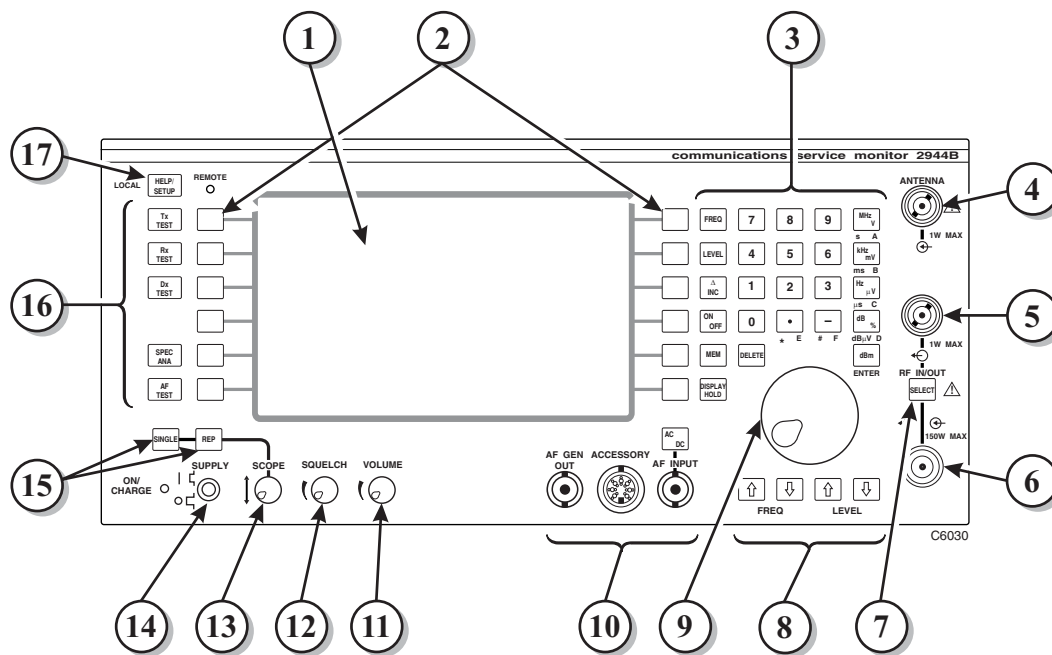

Fig. 3-1 Front panel.

- (1) **Display.** The dominant feature of the front panel is the display screen, used to give information about the operation of the instrument.

Information relating to the state of the instrument, the mode of operation and results of measurements and tests is all given visually on the display screen. See Fig. 3-2, *Typical displays*.

The screen is divided into four main areas. They are:

**The information display area**, which shows the parameters relating to the test, together with settings and results, including bar charts. When the oscilloscope function is called up, all bar charts are removed from the display and the standard or expanded oscilloscope screen displayed. When the SPEC ANA test mode is selected, the display changes to the SPECTRUM ANALYZER screen.

**The test title area**, where the current test description is displayed. LED indicators adjacent to each RF connector show the assignment of the connectors. This information is also shown in the test title area of the display when in Dx TEST mode.

**Soft key menus, left and right.** These areas each have menus of soft key labels designated to the adjacent soft keys. Some modes of operation only require one menu area of six selections. For example, the Tx TEST mode and the AF TEST mode both display and use only the right hand soft keys, the Rx TEST mode only the left hand soft keys. The Dx TEST mode uses the right hand soft keys for transmitter test functions and the left hand soft keys for receiver functions.

## LOCAL OPERATION

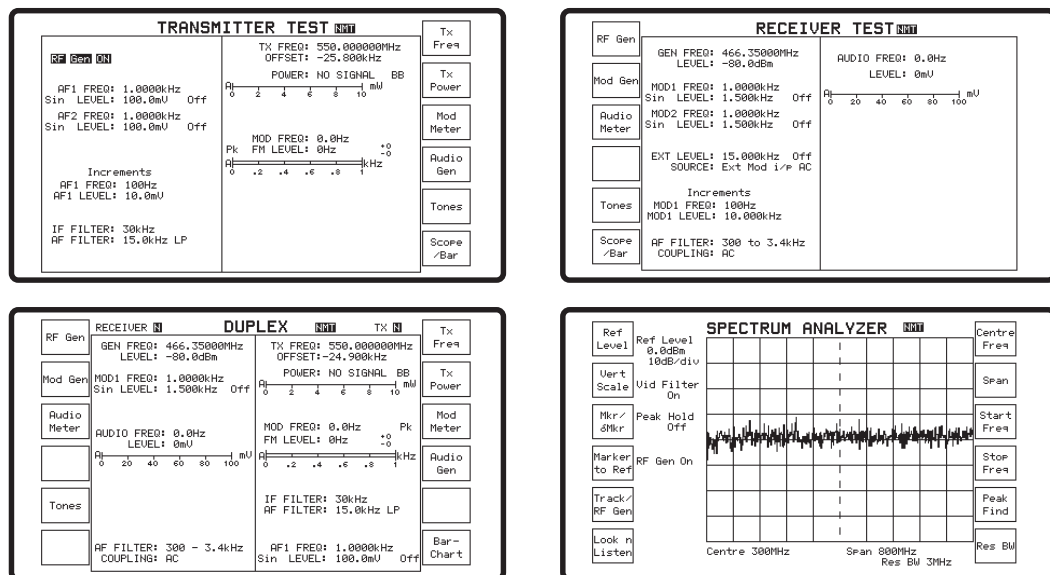

B6012

*Fig. 3-2 Typical displays*

The various keys on the front panel are grouped according to their use or located adjacent to associated items.

- (2) **Soft keys.** To each side of the display screen are six unmarked keys. These are the ‘Soft’ keys referred to in the display description above. The specific function of each of these keys is defined by the instrument software and is indicated by the legend on the label immediately adjacent to it on the display screen.
- (3) **Data Input keys.** The right hand area of the front panel contains the ‘Data Input’ keys. These keys are used to key in data for the various test parameters. They are arranged in three groups:

Function keys on the left of the group are colored orange. They are used to define the parameter to be addressed; frequency, level, increment change or memory store location; before any digits are entered. The [ON/OFF] function key acts directly on the selected function.

Digit keys are in the center of the group and include the minus sign and decimal point. These two keys have alternative symbols printed beneath them on the front panel, which can be entered as data where appropriate. No action other than a normal key press is required, as only one of the three options for each of these keys is relevant to the entry at any one time. The 'Delete' key back-spaces over figures entered on the display to correct any errors. Corrections cannot be made to an entry after a terminator key has been pressed for that entry. The original setting will be retained if an entry is not completed. The incomplete entry will be replaced on the display by the original setting when a key press is made that confirms to the program that the setting being made has been aborted.

Terminator keys used to conclude a parameter value are on the right of the group. They are colored orange.

When setting a modulation level, the entry is completed using the Hz, kHz, MHz or % key. The appropriate modulation type, FM or AM, is automatically selected.

### (4), (5) & (6) RF input and output connectors.

The three sockets at the right hand edge of the front panel are the RF input/output connectors. Refer to the [Performance data](#) section in Chapter 1 for measurement accuracy, maximum power input levels and reverse power limits. The nominal impedance of all RF input and output circuits is 50 Ω.

- (4) **ANTENNA connection.** This is a female BNC connector, for 'Off Air' measurements and monitoring, using a suitable antenna. This connector can also be used for direct input of low-level signals.
- (5) **BNC RF output connector.** This provides output from the RF signal generator.

- (6) **N type RF connector.** This is dual function, input and/or output. A 20 dB Delta attenuator is incorporated within the Service Monitor. This interconnects the 'N type' connector with the RF generator output and the measuring receiver input, through the input/output selector switching.

**WARNING**

**Hot surfaces**

**Take care when touching the RF Input N Type connector after the application of high levels of continuous power. If 50 W is exceeded for a prolonged period, the temperature of the connector can become excessive.**

- (7) **RF input select key.** The [SELECT] key switches through all the RF connector combinations available. The current selection is indicated by LEDs. The ◐ symbol shows the RF output connector and the ◑ symbol shows the RF input connector.

- (8) **Increment adjustment keys.** Under the variable control are the two pairs of increment adjustment keys, **FREQ** (frequency): [↑] and [↓], and **LEVEL**: [↑] and [↓].

These enable the frequency and level of the RF generator or a selected AF generator to be adjusted in pre-defined steps. The assignment and the value of the steps is shown on the display.

The **FREQ** [↑] and [↓] keys can be assigned to the Tx frequency value or either of the audio generators when in the Tx TEST mode, the RF generator or either of the modulation generators when in the Rx TEST mode, or either of the AF generators when the AF TEST mode is active.

The **LEVEL** [↑] and [↓] keys have the same options. The frequency keys and the level keys do not have to be assigned to the same generator.

The **FREQ** [↑] and [↓] keys can be assigned to the RF generator frequency or transmitter frequency as channel increments.

When operating in Dx TEST mode the increment keys are disabled.

The **SPEC ANA** mode uses the **FREQ** [↑] and [↓] keys for span range and center frequency adjustment. The **LEVEL** [↑] and [↓] keys are used for reference level adjustment. See page 3-68.

The span is ranged up or down in a 1, 2, 5 sequence, from 1.0 kHz to 1.0 GHz.

Adjustment to the span by these keys is linear about the center frequency and will not adjust below zero or above the top frequency limit.

The **LEVEL** [↑] and [↓] keys adjust the reference level range of the spectrum analyzer in either 2 dB or 10 dB steps depending on the setting of the reference level vertical range.

- (9) **Variable control.** The large rotary control under the data input keys is used to make adjustments to frequencies and levels that require a finite change such as when matching a test signal to an undefined signal, or assessing the squelch operating level of a receiver. It has no mechanical stops. This control is also used to select items or digits from displayed lists, in conjunction with the **TONES** modes.

- (10) **Audio connections.**

**AF GEN OUT socket.** The signal available at this BNC socket is the combined output from both or either of the AF generators and/or the tones generator.

**AF INPUT socket.** Signals fed into this BNC socket can be measured using the AF counter, the AF voltmeter and the distortion measuring circuits. It is also the input for the digital oscilloscope.

**ACCESSORY socket.** Used for connecting accessories, whose presence is automatically detected. Also used for direct connection of a headset, allowing modulation of the signal generator by a microphone and audio signal monitoring through headphones.

When using the accessory microphone with PTT switch, automatic switching between Tx and Rx modes using the PTT switch is possible.

**DISPLAY HOLD key.** To the left of the variable control is the [DISPLAY HOLD] key. Pressing this key at any time will freeze the display and prevent any adjustment to parameters displayed on the screen. The soft key menu changes to show two keys, *[Store]* and *[Print]*.

The *[Store]* key, gives access to the STORE/RECALL screen and menu. The use of this feature is explained on page 3-90

The *[Print]* key is used to start the Screen Print function. This causes a hard copy of the held screen to be printed onto a suitable printer.

The use of the Screen Print feature is explained under the heading 'Printer' on page 3-93.

**AC/DC. AF input coupling option key** Located above the AF input socket, this key toggles the AF input circuit between direct and capacitive coupling. The option selected is displayed on the screen.

- (11) **Volume.** This control varies the level of the AF signal fed to the loudspeaker.
- (12) **RF receiver squelch level control.** When monitoring the demodulated output through the loudspeaker or headphones, the RF level below which signals are isolated from the AF circuits can be controlled. Clockwise rotation of the squelch control raises this level and anti-clockwise rotation decreases it.
- (13) **Scope trace vertical position.** This adjusts the vertical position of the trace within the graticule.
- (14) **SUPPLY switch.** Pressing in this push-button powers up the instrument from either the AC or DC source. See *Getting started* on page 3-9.
- (15) **Oscilloscope sweep mode keys.** The [SINGLE] and [REP] keys, located above the scope vertical position control, select the oscilloscope sweep mode.
- (16) **Test mode select keys.** On the left of the front panel are five blue keys. These are the 'Test Mode Select' keys, used to put the instrument into one of the basic test modes. They are active whenever the instrument is powered up and under local control.
- (17) **HELP/SETUP key.** Above the test mode select keys is the '**HELP/SETUP**' key.

Pressing this key will cause the HELP/SETUP access screen to be displayed if the instrument is under local control. This does not interrupt any on-going function of the Service Monitor. See *HELP/SETUP* on page 3-11

When the instrument is under remote control, pressing this key will return control to LOCAL *unless* an instruction to prevent local operation has been sent from the remote control device.



## Rear panel controls and connectors

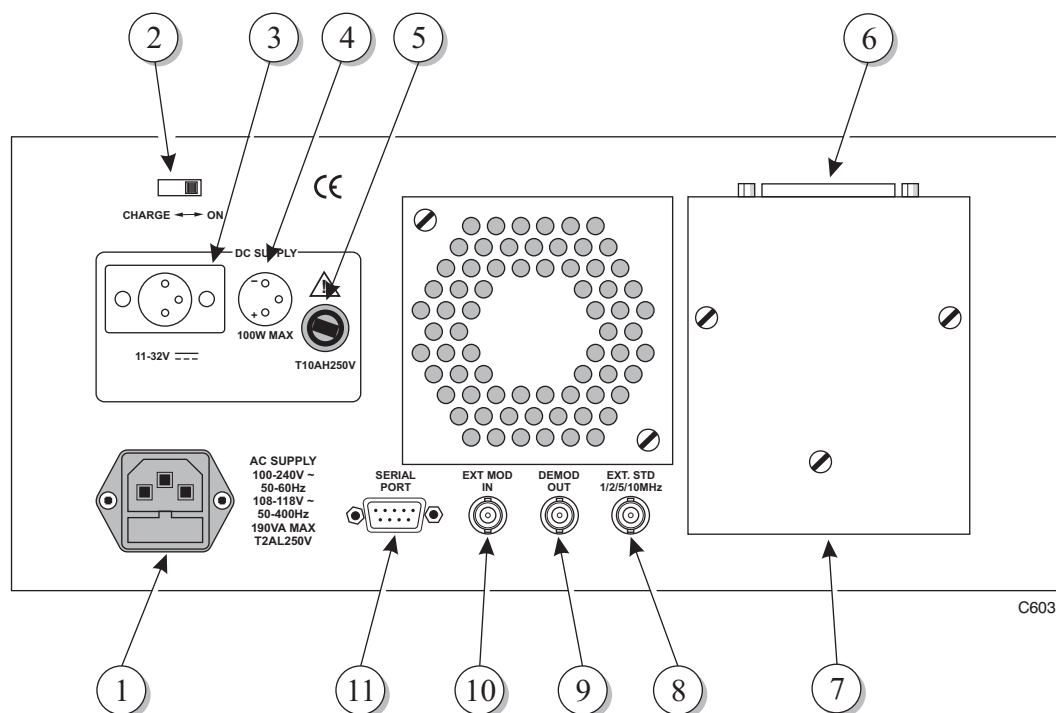

Fig. 3-3 Rear panel layout, (with optional GPIB fitted)

On the rear panel of the instrument are:

- (1) **AC power supply input** connector. One range for all mains voltages. See the *Performance data* section in Chapter 1. The AC supply fuse is contained within this connector.
- (2) **Power switch**. The power switch has two positions: ON or CHARGE. The ON position connects the output of the Service Monitor's power supply module to the instrument; the CHARGE position allows the power supply to recharge the internal battery (if fitted). See [Getting started](#), on Page 3-9.
- (3) **DC supply input voltage** connector. For powering the instrument from DC supplies. See [Performance data](#), in Chapter 1.
- (4) **DC supply pin connection diagram**. Shows the polarity of the DC power connector
- (5) **DC supply fuse**.
- (6) **GPIB interface connector**. This connector is only present when the GPIB interface option is fitted. Connection details are given in Chapter 2, under [Remote control connections, GPIB](#).
- (7) **GPIB interface unit**. Optional. See (6) above.
- (8) **External frequency standard input**. This can be 1, 2.5 or 10 MHz; the Service Monitor identifies the applied frequency. In the event of external standard failure, control reverts to the internal standard.
- (9) **Demodulated signal output**. The demodulated signal removed from the input RF signal is brought to this connector for feeding to external equipment.
- (10) **EXT MOD IN** (External modulation input). A signal applied to this connector can be used as a modulation source for the receiver test signal. The input level of the applied signal should be 1.00 V (RMS sinewave) in order to maintain the correlation with the modulation level calibration. The frequency of the signal should be within the range of the internal modulation source of 20 Hz to 20 kHz (AM), DC to 100 kHz (FM).
- (11) **Serial port**. The SERIAL PORT connector provides RS232 interface facilities for remote control. It is also used for the serial output to a printer. Connection details are given in Chapter 2, under [Remote control connections, RS232](#).

## Getting started

### (Applying power and selecting test modes)

In normal operation, the rear panel ON/CHARGE switch is set to the ON position.

When the front panel SUPPLY switch is pushed in, the instrument powers up from either an AC supply or a DC supply provided by the optional internal battery. If both AC and DC supplies are connected, the AC supply takes precedence. A small trickle charge is also supplied to the DC supply.

Moving the rear panel ON/CHARGE switch to the CHARGE position charges the internal battery, if fitted. Battery charging is indicated by the “on/charge” LED flashing. When the battery is fully charged the LED is illuminated continuously.

A discharged battery will be fully charged after 4 hours approximately. No charging takes place when the instrument is on.

NOTE: When new the Ni-mH battery pack may exhibit reduced capacity and incomplete charging. The pack should be given several charge/discharge cycles to realize full capacity.

With the instrument on and running from AC or DC supplies, if the supply disappears the battery will not take over. This is to prevent accidental discharge of the battery pack. To enable the battery the power switch must be returned to off, left for 10 seconds, and then turned on.

The center position is OFF.

With a power source connected, switching on the instrument causes the cooling fan to operate and one of the test mode menus to be displayed. Which screen is displayed depends on which store is selected as the 'Power Up From' store ([HELP/SETUP], [*Setup*], [*Power Up From*] key sequence).

The low battery warning is activated when the voltage at the DC terminals falls to approximately 11 V.

If you are unfamiliar with the instrument a few minutes spent exploring the setup menus and test modes is helpful.

The following explanation of keys and menus will assist in this.

## Test mode screens and menus

The five test modes are selected by pressing the appropriate MODE key. These are light blue, with dark blue lettering. (Item 16 in Fig. 3-1, *Front panel*). Select each in turn and observe the display presented.

Each area of six soft key labels forms a menu. Various menus are called up as a result of selecting a change of test mode or by pressing a soft key within a test mode.

There are fold-out diagrams at the end of this chapter that show the screens displayed when each of the mode keys is pressed. These also show branching to the second or third level screens and menus. A diagram of the screens accessed from the HELP/SETUP key is also included. These fold out diagrams are numbered to correlate with the associated key position as follows:

- (1.0) HELP/SETUP
- (2.0) Tx TEST
- (3.0) Rx TEST
- (4.0) Dx TEST
- (5.0) SPEC ANA
- (6.0) AF TEST

References in the manual to specific screens on the fold out diagrams is given as in the following example:

Fold out diagram (2-3-3). This is the screen shown after pressing the [Tx TEST] mode key, then the [*Mod Meter*] key (third key down), followed by the [*AF Filter*] key (third key down). Where there are keys on both sides of a screen, keys 1 to 6 are on the left, keys 7 to 12 on the right.

To move to the top level menu of any test mode, including the currently active mode, press the relevant 'MODE' key.

For detailed use of specific TEST MODES see the [section](#) later in this chapter relating to that test mode.

## HELP/SETUP

Pressing the [HELP/SETUP] key, at any time, will display the screen shown in fold out diagram (1-0), or a variation of it. Displaying the HELP/SETUP screen does not interrupt any ongoing operation or test.

The center panel of the screen lists the following information:

Serial number of the Service Monitor  
Software fitted, with the version codes and part numbers.

### Help

The help facility is accessed by using the [HELP] key. Each soft key in the help menu displays 'On Screen Help' relating to the blue system key to the left of it. The [Return] key removes the on screen help and displays the top-level screen of the mode from where HELP/SETUP was selected.

### Self Test

Pressing this key gives access to the SELF TEST function of the Service Monitor. Refer to *Self tests and acceptance tests* in Chapter 2, for details.

### Diagnostic

The DIAGNOSTIC screen can only be accessed by entering a protection code. When accessed, it allows a low level of software fault diagnosis to be undertaken. Certain areas of memory can also be reset from this screen. Details of access are given in the maintenance manual relating to this instrument.

### Calibrate

Access to the CALIBRATION screen is also code-protected. Details relating to access and use are given in the maintenance manual relating to this instrument.

### Backlight

This key is the ON / OFF control for the display backlight.

### Brightness

Selecting this key allows the illumination level of the display backlight to be varied using the variable control. The illumination level can also be adjusted by the entering a number between 0 and 255 using the data input keys.

### Options Fitted

Shows which options are fitted to the Service Monitor (except Option 3).

### Setup

#### RF Setup

Press this key to allow selection of RF generator facilities options: the description starts on page 3-15. RF setup is shown in fold-out diagram (1-10-2). The keys described may differ if some options are fitted. See the descriptions relating to those options for details.

#### AF Setup

Press this key to allow selection of AF level measurement units, GPIB address setting, remote control option selection and serial port setup: the description starts on page 3-17. AF setup is shown in fold-out diagram (1-10-3).

The keys described may differ if some options are fitted. See the descriptions relating to those options for details.

**AF Filters**

The AF Low pass and band pass filters available for the Rx TEST mode, for the AF TEST mode and for the modulation meter within the Tx TEST mode can be customized from the setup page accessed from this key.

The AF Filters setup page is shown below.

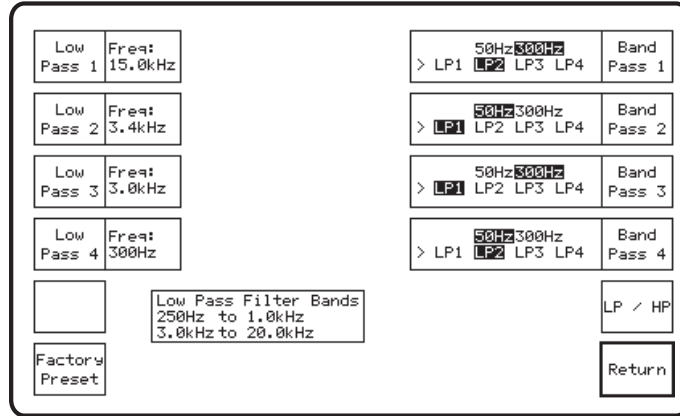

B5888

Fig. 3-4 AF Filter HELP/SETUP page

**Factory Default filter settings**

The [Factory Preset] soft key will reset all of the filters to their 'Factory Default' settings. The low pass filter settings are 15.0 kHz (LP1), 3.4 kHz (LP2), 3.0 kHz (LP3) and 300 Hz (LP4).

The 'Factory Default' band pass filter settings are as shown below:

Band pass 1	300 Hz high pass	3.4 kHz low pass (LP2)
Band pass 2	50 Hz high pass	15.0 kHz low pass (LP1)
Band pass 3	300 Hz high pass	15.0 kHz low pass (LP1)
Band pass 4	50 Hz high pass	3.4 kHz low pass (LP2)

**Low pass filters**

The four low pass preset filters can each be set to any frequency within the range 250 Hz to 1.0 kHz and 3.0 kHz to 20.0 kHz.

The soft keys associated with the low pass filters are on the left of the setup page.

To set the required frequency, first press the soft key relevant to the low pass filter to be set. The Freq: legend will become highlighted in reverse video. Use the Data Input keys to enter the required frequency and then press the appropriate termination key (Hz or kHz.).

This frequency will now be assigned to that low pass filter.

### Band pass filters

The four band pass filters can each be customized to your requirements by selecting low pass and high pass elements from the as required. The High pass element can be either 50 Hz or 300 Hz, the low pass element can be any of the four preset low pass filters.

To select the required high pass element, first press the *[LP / HP]* soft key once or twice to move the > indicator to the high pass elements on all four soft key settings boxes. Next, press the soft key relevant to the band pass filter to be set. The 50Hz or 300Hz settings will toggle. Repeat this to select the required filter element.

To select the required low pass element, first press the *[LP / HP]* soft key once or twice to move the > indicator to the low pass elements on all four soft key settings boxes.

Next, press the soft key relevant to the band pass filter to be set. Each press will select one of the LP1, LP2, LP3 and LP4 settings in sequence. Repeat until the required low pass filter element is selected.

This setup will now be assigned to that band pass filter irrespective of from what test mode it is accessed.

### Logic Lines

The optional Accessory Port on the rear panel allows the control of external devices by logic control from the instrument. The use of this facility, how to make connections to it and how to set up the switching is explained under *Accessory port (rear optional)* starting on page 3-94

The state of the logic lines are set from the Set-up page accessed by pressing the *[Logic Lines]* soft key.

### GPIB Address

Pressing the *[GPIB Addr]* key allows a new GPIB address to be entered; use the data input keys to enter the digits, followed by the ENTER terminator key. It may have a value between 1 and 30.

### Remote Control

The Service Monitor can be operated by remote control using either the RS232 (serial) port or the optional GPIB (IEEE 488) interface. The *[Remote Control]* key toggles between the two options. The active function is highlighted in inverse video.

### Serial Setup

The *[Serial Setup]* key gives access to the serial port setup menu. The parameters that must be set for compatibility with other equipment connected to the port are:

Baud Rate; Parity Bit; Character Length; Stop Bit; and Handshaking.

Setting up of the serial port is described in the Chapter 4 of the Programming manual (46882/683) under *Preparing the Service Monitor for remote operation*.

### Printer Setup

A menu of printer type options and printer port selection is accessed through this key. The options are:

Epson FX80 or FX100.

Laser Printer 75 dpi, 100 dpi, 150 dpi.

RS232 serial port or 'Centronics' parallel port. The selected port is highlighted in inverse video. If the parallel port option is not fitted, it is not shown on the menu, and the *[Printer Port]* key enables or disables the RS232 serial port as a printer port.

### Power Up From

Successive presses of this key will toggle through the options available for configuration of the Service Monitor at 'Power Up'.

#### Last Used Store 0

Store 0 is loaded with the current settings each time power is removed from the instrument. With this selection made, the instrument will power up to the same settings as when power was removed, whether this was by user action or through power failure.

#### Preset Store 1

Store 1 contains the factory preset settings. With this selection made, the instrument will power up to the Rx TEST mode with all settings, for every mode, to the factory preset settings and options.

#### User Store 2

Store 2 is the first user accessible store, which is loaded through the user memory function. With this selection made, the instrument will power up to the settings stored in user memory store 2 without having to access the memory as a separate function.

Access to the user memory is by pressing the orange [MEM] key. See [Stores, settings/results](#), later in this chapter, starting on page 3-90.

### Return

Returns to the last screen displayed prior to the pressing of the Help/Setup mode key.

### Return (on the HELP/SETUP screen)

Returns to the last used main mode.

## RF Setup page

### RF Counter Resolution:

The RF counter resolution can be set to 0.1 Hz, 1 Hz or 10 Hz. Selecting 1 Hz will slow the screen update rate by a factor of 10:1, selecting 0.1 Hz will slow it by a factor of 100:1. The choice is made by stepping through the three options using the soft key adjacent to the text.

**Note**

The speed of the autotune function is also related to the selected RF Counter Resolution

### RF Level Measured in:

The RF level from the transmitter being tested can be displayed in terms of Watts into a 50 ohm load, voltage across the 50 ohm load or dBm into 50 ohm. The choice would normally be made so as to match the specification parameter of the transmitter under test. The selection is made by pressing the soft key adjacent to the text. This will toggle through the three options.

### RF Input Level

Holds the receiver's input attenuator at a fixed level. The level is set manually by using these up/down soft keys. The displayed values indicate the maximum input level that should be applied to the receiver. A held input level is indicated on the Tx and Dx screens by a red inverse video 'H'.

### Auto Range

Sets the receiver input attenuator to autorange.

### Atten Hold:

The Attenuator Hold facility provides a 'seamless' range of RF Generator output that is not subject to switched attenuator action. The available range is up to 20 dB, with a guaranteed range of 10 dB.

### Atten Hold Level:

The value entered here sets the upper level of the 'seamless' range of RF Generator output. The value must be within specified output range of the RF Generator. There is no account taken of any RF Power External Attenuator settings entered in the Test Set, neither is the settable range restricted when the 'N' type Connector is selected.

### RF Power Ext Atten:

The value of any attenuator entered here is considered as part of the instrument and all power measurements will be as from the input to the attenuator, not to the instrument input. Similarly power output levels will be adjusted to take account of the external attenuator value entered.

To enter a value of attenuation, which must be in dB, press the adjacent soft key, key in the digits of the value using the data entry keys and then press the dB terminator key.

The entered value will be applicable to all RF connectors into and out of the monitor. When changing test setups or test modes this must be taken into account to prevent erroneous readings.

The indicator **A** is shown against any signal level which has been calculated to include the external attenuator.



### **Rx = Tx Offset Freq:**

A setup option within the Tx TEST mode (Rx=Tx) will set the signal generator used for receiver testing to the measured frequency of a transmitter being tested. An Rx=Tx offset frequency entered here will cause the signal generator frequency to differ from the measured transmitter frequency by the offset frequency. To enter an offset frequency, press the adjacent soft key, key in the appropriate digits, using the minus key and the decimal point key if necessary, then use the relevant terminator key, (MHz, kHz or Hz). A positive figure will set the signal generator frequency above the measured transmitter frequency, while a negative figure will set the signal generator to a lower frequency than the transmitter.

### **RF Level in:**

The selection is made by toggle action of the soft key. The PD or EMF flag is shown against output levels displayed as voltage or dB $\mu$ V.

With the EMF option selected, the displayed RF output level shows the open circuit voltage available at the RF output connector.

With the PD option selected the displayed RF output level shows the voltage that would be present across a 50  $\Omega$  load.

### **Return**

Returns to the Setup page.

### AF Setup page

This page allows the following optional settings to be selected:

#### **Audio Level Measured in:**

Repeated presses of the adjacent soft key will toggle through Volts, dBm, dBV or Watts and highlight the selection in inverse video.

The level of a signal applied to the AF input socket is measured in terms of the selected option. This will then apply to all subsequent measurements.

The indicated output level from the AF generators is not affected by this selection.

#### **Audio Input Impedance Match:**

The impedance selected by this key is used by the Service Monitor to calculate and display the measured voltage as a power (in dBm). Note that the impedance of the AF input remains high. To obtain an accurate measurement the necessary terminating impedance must be added externally.

#### **Audio Input Impedance:**

This key is only active if the 600  $\Omega$  interface option is fitted. Pressing it will toggle between the 600  $\Omega$  balanced input impedance or the standard high impedance. The AF input connector on the front panel is used in either case.

#### **Audio Output Impedance:**

This key is also only active if the 600  $\Omega$  interface option is fitted. Pressing it will toggle between the 600  $\Omega$  balanced output impedance or the standard low impedance. The AF generator output connector on the front panel is used in either case.

#### **20 dB audio attenuator:**

This key is also only active if the 600  $\Omega$  interface option is fitted. Repeated presses of it will insert or remove a 20 dB attenuator from the output circuit of the audio amplifiers. With the attenuator in circuit the maximum output is limited to 400 mV. The adjustment resolution is increased to 0.01 mV below 40 mV and to 0.1 mV from 40 mV to 400 mV.

**AF Distn, SINAD, S/N Averages:**

When distortion or SINAD tests are made to receivers using the Rx TEST mode or AF TEST mode, the results displayed are obtained by averaging the results of a number of measurements. This allows the user to balance the speed of testing against greater repeatability of measurement. The number of measurements made can be set within the range 1 to 20 by entering the required figure using the data input keys.

Each measurement is made using a certain number of noise samples; this variable can be changed, as follows.

**Noise Samples (X10):**

This allows the number of noise samples used in each noise and distortion measurement to be changed. Numbers of samples are displayed in tens, up to a maximum of 200 samples. More noise samples should be used when the signal measurement is stable but the residual is noisy; fewer samples should be used when the signal is less stable.

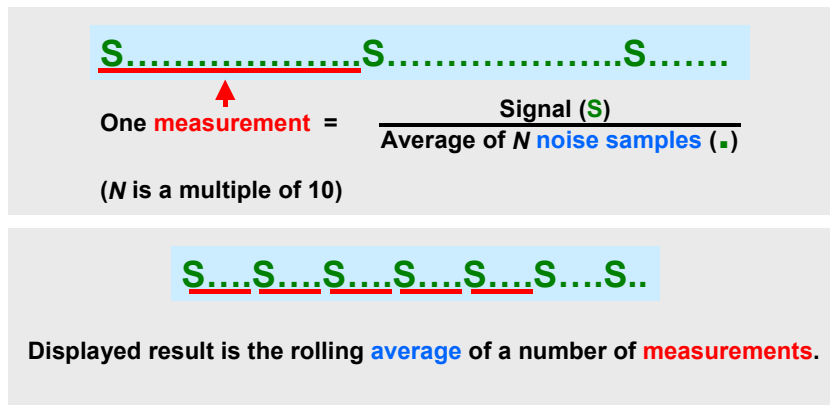

*Fig. 3-5 Relationship of measurement and number of samples*

**Return**

Returns to the Setup page.

## Bar charts

The bar charts used to indicate signal levels can be set to autorange or to user selected ranges. The current state of each bar chart is shown by either an **A** (for Autoranging) or **H** (for Held range) at the left of it. The top level screen of Tx TEST, Rx TEST, Dx TEST and AF TEST, all have a *[Scope/Bar]* key.

Pressing this key will change the soft keys to those shown below. The function of each key is explained.

<b>[Barchart Select]</b>	This key will select each visible bar chart in turn. The selected bar chart is indicated by a highlighted A or H at the left of it.
<b>[Auto range]</b>	This key will set the selected bar chart to autorange. If it is currently set to autorange, the key will have no effect.
<b>[▶◀]</b>	Each press will change the bar chart to the next <i>highest</i> range. If the selected bar chart is set to autorange, the first press will remove autoranging and hold the current range. The next press will change the range. When the highest range is set, subsequent presses will have no effect.
<b>[◀▶]</b>	Each press will change the bar chart to the next <i>lowest</i> range. If the selected bar chart is set to autorange, the first press will remove autoranging and hold the current range. The next press will change the range. When the lowest range is set, subsequent presses will have no effect.
<b>[Scope/Bar]</b>	Pressing this key once, will remove the bar charts from the display and cause the normal oscilloscope to be displayed. Subsequent presses will display the expanded oscilloscope, then the bar charts again.
<b>[Return]</b>	This key will display the top level screen of the selected test mode.

## Spectrum analyzer

The spectrum analyzer (SPEC ANA) mode presents a graphical display of Radio Frequency against RF level over a selected sweep of the RF spectrum.

Data relating to the setup and to measurements of the signals being analyzed is presented on the periphery of the display.

As well as the basic spectrum analyzer function, the monitor has a 'Look and Listen' function that allows the operator to listen to the demodulated signal extracted from the RF signal being examined.

## Oscilloscope

The digital oscilloscope function, available from the Tx, Rx and AF test modes, displays signal waveforms on part of the display screen. The operation of the oscilloscope function is described in detail later in this chapter under *Oscilloscope*, starting on page 3-88.

When reference to the oscilloscope facility is necessary when describing other functions, this is indicated by heading the reference, **\*OSCILLOSCOPE\***, **\*STANDARD OSCILLOSCOPE\*** or **\*EXPANDED OSCILLOSCOPE\*** as appropriate.

## Using the test modes

### Brief descriptions

As the Service Monitor is a duplex instrument, the RF signal generator and the receiver circuits are able to operate simultaneously. This allows mobile transceivers to be tested under their normal operating conditions, with both their receiver section and transmitter section functioning. By selecting a particular test mode on the Service Monitor, one or both sections of the transceiver can be studied. A brief description of the function of each test mode is given below. Detailed user instructions follow under the relevant headings.

#### Tx TEST

With Tx TEST selected, the **TRANSMITTER TEST** screen is displayed and access to all Tx TEST mode features is available. See fold out diagram (2-0) at the end of this chapter.

The AF voltmeter makes measurements to the signals from the Service Monitor demodulator and displays the results.

The RF signal generator is active, producing an RF signal at the frequency and level set in the Rx TEST mode. This signal will be modulated at the level and frequency set, if the modulation generator selection does not conflict with the requirements of the Rx TEST mode.

#### Rx TEST

With Rx TEST mode selected, the **RECEIVER TEST** screen is displayed and access to all Rx TEST mode features is available. See fold out diagram (3-0) at the end of this chapter.

The AF voltmeter makes measurements to the signal obtained from the demodulated output of the mobile transceiver and fed into the AF input socket on the front panel of the Service Monitor. The AF generators are active at the frequencies and levels set in the Tx TEST mode and their output routed to the AF GEN OUT socket, if the AF generator selection does not conflict with the requirements of the Tx TEST mode.

#### Dx TEST

With Dx TEST selected, the **DUPLEX TEST** screen is displayed and access to transmitter and receiver test features is available. See fold out diagram (4-0) at the end of this chapter. These features are not as comprehensive as those available from the **TRANSMITTER TEST** or **RECEIVER TEST** screens, but do allow measurements to be made to the major parameters. The Service Monitor has two AF generators, either or both of which can be used to modulate the transmitter being tested or the RF generator. However, each generator can only serve one function at the same time. There is only one AF measurement path, which is switched by the software between receiver test and transmitter test functions.

#### SPEC ANA

With SPEC ANA selected, the SPECTRUM ANALYZER screen is displayed and access to the spectrum analyzer features is available. See fold out diagram (5-0) at the end of this chapter. The RF signal generator is active, producing an RF signal at the frequency and level set in the Rx TEST mode, if the tracking generator feature is not selected. The spectrum analyzer tracking generator signal is provided by the RF generator.

The modulation generators will modulate the RF signal generator, with the same provisos as in Rx TEST mode. If the **LOOK AND LISTEN** screen is displayed, AF Gen 2 is used to provide the sweep signal, therefore it is not available to provide modulation.

#### AF TEST

With AF TEST selected, the **AUDIO TEST** screen is displayed and access to the AF TEST features is available. See fold out diagram (6-0) at the end of this chapter. The RF generator is disabled.

### Press To Talk facility

A mode switching capability is provided by the 'Microphone with PTT switch' optional accessory. See *Performance data, optional accessories*, in Chapter 1.

With 'microphone' selected as the external modulation source and the instrument operating in the Tx TEST mode, pressing the PTT switch causes the instrument to switch to the Rx TEST mode.

With the instrument set to the Rx TEST mode or Dx TEST mode, pressing the PTT switch allows voice modulation of the RF signal from the Service Monitor, but mode switching does not happen.

### Tones

A soft key designated [*Tones*] is included in the top level menus of the Tx TEST mode, Rx TEST mode, Dx TEST mode, and AF TEST mode.

Pressing this key will display the menu shown in fold out diagram (2-5), (3-5), (4-5) or (6-5), and give access to the 'TONES' test facility. This facility is used to provide modulation generators and demodulation decoders to simulate the various coded calling signals used on mobile radio systems for automatic selective calling of mobile transceivers.

### General

The instructions for transmitter testing assume that the Tx TEST mode has been selected, and for receiver testing assumes that the Rx TEST mode has been selected. However, these instructions apply equally to the Dx TEST mode. References are made to Dx TEST mode to clarify this, or to identify a difference in presentation. These references are headed \*DUPLEX\*.

The Dx TEST mode, the Oscilloscope function, and the TONES facility, each have a section of this chapter dedicated to their operation.

## Tx test (transmitter testing)

### Overview

The Communications Service Monitor has been designed to test the performance of mobile communication equipment. This section explains the use of the Tx TEST mode. Typical uses are:

- Performance checking following manufacture
- Routine quality assurance testing
- Workshop or field fault diagnosis etc.

The tests that need to be carried out will depend on the specification of the transmitter and the reason for testing, however a generalized list would be:

Transmitter power Transmitter frequency RF distortion Spurious outputs Modulation characteristics Modulation frequency response Companding/limiting Modulation distortion
--

This Service Monitor will perform all of the above tests.

With the Tx TEST mode selected, the screen and menu shown in fold out diagram (2-0) is displayed.

Using this screen and menu, the Service Monitor is set up for transmitter testing, and the test results displayed.

The sections of the monitor available for transmitter testing are:

The AF generators, used to provide a modulating signal for the transmitter.

The audio tones generator. Used to provide sequential tones for POCSAG and DCS systems.

The RF power meter.

The RF counter.

The modulation meter, to measure the depth of amplitude modulation or the deviation of frequency modulation and to recover the modulating signal for other tests. The demodulated output is fed to the audio amplifier, and can therefore be monitored on the loudspeaker or on a headset connected to the accessory socket. The SSB option allows Single Side Band modulation to be demodulated.

The oscilloscope, to examine the wave form of the demodulated signal.

As well as setting up the major sections of the Service Monitor, the following parameters are selected from the TRANSMITTER TEST screen:

The TRANSMITTER TEST screen allows setting of the following;

IF filter bandwidth.

AF filter pass-band.

De-emphasis filtering.

Distortion measurement methods.

Connections

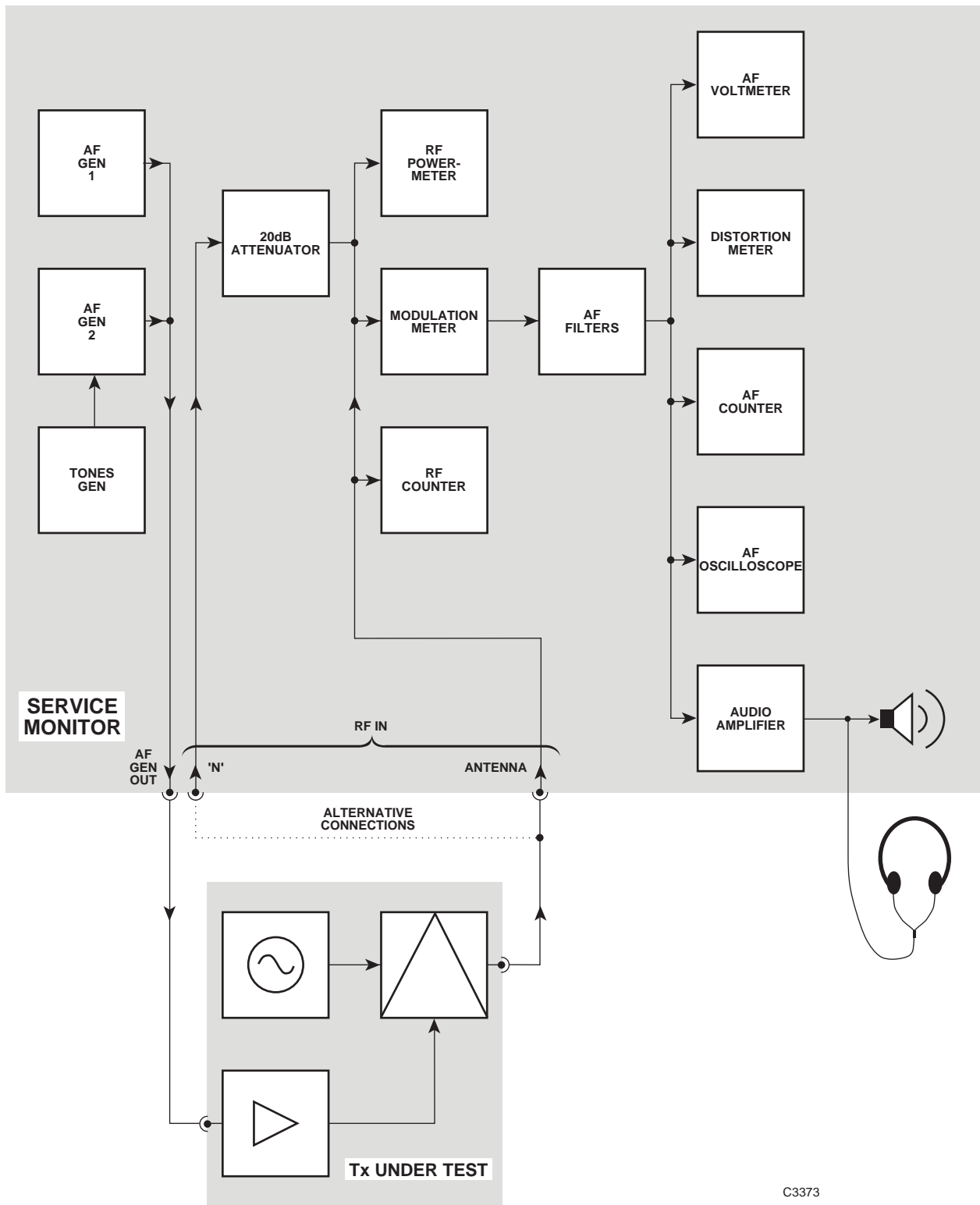

Fig. 3-6 Transmitter test connections

The transmitter and the Service Monitor are connected as shown in Fig. 3-6, *Transmitter test connections*. The block diagram of the Service Monitor shows the signal routing within it.



The Audio frequency input connection to the transmitter must be to the audio input, in place of the usual microphone input. This connection will vary for differing types of equipment. Points to note are:

- The microphone must be disconnected, as any input from it would affect the performance of the test.
- The microphone and its cable may complete the 'keying' circuit of the transmitter using a 'press to talk' switch, in which case an alternative arrangement must be provided.
- The RF output connection from the transmitter should be made using good quality RF cable with correctly fitted connectors. Worn connectors and damaged or kinked cable can give rise to high levels of reflected power. This can cause misleading results and possible damage to the transmitter.
- Consider the power output of the transmitter and connect to the appropriate input connector on the monitor. The maximum power to the BNC (Antenna) socket is 1 W and to the 'N-Type' connector 150 W. If the transmitter output power exceeds this level then a suitable power attenuator should be connected between the transmitter and the monitor or a calibrated 'sniffer' used to take a sample of the output, using a dummy load if necessary.
- The power source for the transmitter should be reliable and stable. The battery of a vehicle may discharge if supplying a transmitter during prolonged testing or the 'earth' common return connection may become open circuit if the transmitter is removed from its normal location.

The procedure for making each of the tests listed above follows. Some of the tests may require separate operations and others will only require a reading to be made.

### **WARNING**

#### **Hot surfaces**

**Take care when touching the RF Input Type N connector after the application of high levels of continuous power. If 50 W is exceeded for a prolonged period, the temperature of the connector can become excessive.**

#### **Setting up**

When all the required connections have been made, select the Tx TEST mode to display the screen and menu show in fold out diagram (2-0).

Set the parameters or options to suit the test requirements, from the TRANSMITTER TEST menus.

The complete setup can be stored by making use of the internal setup/results memories. This feature is described under *Stores, settings/results*, later in this chapter, starting on page 3-90.

#### **RF generator state**

This Service Monitor is a duplex instrument as mentioned earlier. (See *Using the test modes*, on page 3-21.) The state of the RF generator is shown on the TX TEST display by the legend **RF GEN ON** or **RF GEN OFF**. The state of the RF generator can be switched by pressing the top left soft key.

#### **Input attenuator**

The Service Monitor's input attenuator can be preset to suit the RF input level expected from the transmitter, or it can be set to auto-range. See page 3-15 for details.

#### **Tx frequency**

Press the *[Tx Freq]* key.

The soft key options change to those shown in fold out diagram (2-1).

The receiver circuits of the Service Monitor must be set to the RF output frequency of the transmitter under test. This can be set manually using the data input keys, or automatically by pressing the *[Auto Tune]* key.

### Manual frequency setting

Range; 100 kHz to 1.05 GHz

With the **FX** **FREQ** legend highlighted, data can be entered from the keyboard to the Tx FREQ parameter. As the entry can only be a frequency setting, it is not necessary to select the orange [FREQ] key. Enter the required frequency by using the digit keys and the decimal point key if relevant. The resolution of the RF FREQ entry is 1 Hz, but it is not necessary to enter every digit down to the least significant place if a ‘multiplier’ terminator key is used.

The entry is completed by pressing a terminator key. Using the [MHz], [kHz] or [Hz] key causes the entered frequency to be displayed according to normal convention. The following examples explain further.

Pressing:

[1] [2] [5] [MHz]	will display	125.000000 MHz
[1] [2] [5] [kHz]	" "	125.000 kHz
[1] [2] [5] [0] [kHz]	" "	1.250000 MHz
[1] [.] [2] [5] [MHz]	" "	1.250000 MHz
[1] [2] [5] [0] [0] [0] [1] [Hz]	" "	1.250001 MHz

### Variable control

With the **FX** **FREQ** legend highlighted, the Tx FREQ parameter can be adjusted by using the variable control.

### Frequency increment

The FREQ [ $\uparrow$ ] and [ $\downarrow$ ] keys can be assigned to transmitter frequency adjustment. Refer to the section on [incremental adjustments](#) that starts on page 3-67.

### Automatic frequency setting

Pressing the *[Auto Tune]* key causes the Service Monitor to sweep over the RF input range and lock onto the strongest signal present on the selected RF input socket. The mean frequency of the signal is displayed against the Tx FREQ legend, with Auto tune replacing OFFSET.

**Note**

**SSB (if fitted). The autotune function may not operate when attempting to tune to an SSB transmitter unless a steady tone is being used as a modulation source. The frequency to which the Service Monitor will tune will be the true RF frequency of the sideband and not that of the channel frequency.**

Pressing the *[Rx=Tx]* key causes the RF generator used for the Rx TEST mode to be set to the same frequency as the measured RF from the transmitter under test. A frequency offset facility can be set up which gives a set difference between the frequency of the measured transmitter RF and the set frequency of the receiver test generator. ( $Rx=Tx \pm \text{offset}$ ). See the option selections within the RF Setup page (page 3-15), for more information.

Pressing the *[Offset Hz/ppm]* key causes the Frequency Offset readout (error from the set frequency) to be displayed as a frequency or in parts per million of the set Tx frequency.

After setting the Tx FREQ and any associated adjustments, use the *[Return]* key to revert to the original TX TEST menu.

### Tx power

The *[Tx Power]* key gives access to RF power measurement functions or associated functions.

#### Broad Band or Narrow Band power

The *[Broad/Narrow]* key selects which of the RF power measurement methods is operative. The selected method is indicated on the display by the letters BB or NB to the right of the digital power reading. The use of this facility is explained under *Making measurements* later in this chapter. See page 3-32.

### Modulation meter, demodulation options setup

Set up the demodulation options to be compatible with the transmission from the unit under test. Press the *[Mod Meter]* key. The soft keys change to the demod soft keys shown in fold out diagram (2-3).

#### Modulation Type

The Service Monitor can demodulate AM and FM signals. The demodulated signal is made available at the 'DEMOD OUT' connector on the rear of the instrument. SSB signals can be demodulated if the SSB option is fitted.

The *[AM/FM]* key, or *[AM/FM/SSB]* key, is used to select the appropriate modulation type by sequential key presses. The MOD LEVEL indication within the main display becomes suffixed by % for AM; and by MHz or kHz for FM. When SSB has been selected, no modulation level is shown, either digitally or as a bar chart.

Selecting the modulation type for Tx TEST does not change the current modulation type set on the Service Monitor RF generator.

### SSB Input sensitivity

No RF carrier signal is produced by SSB transmitters. Therefore the automatic gain control circuits of the Service Monitor cannot respond to these signals.

When 'SSB' demodulation has been selected, the RF sensitivity of the Service Monitor can be controlled manually. Three sensitivity settings are given as soft key choices; high, medium and low. The approximate sensitivities of these are shown in the following table:

<i>[High Sens]</i>	-90 dBm to -30 dBm at 'N type' -110 dBm to -50 dBm at 'Antenna'
<i>[Med Sens]</i>	-30 dBm to +20 dBm at 'N Type' -50 dBm to 0 dBm at 'Antenna'
<i>[Low Sens]</i>	+20 dBm to +50 dBm at 'N Type' 0 dBm to +30 dBm at 'Antenna'

### WARNING

#### Hot surfaces

Take care when touching the RF Input Type N connector after the application of high levels of continuous power. If 50 W is applied for a prolonged period, the temperature of the connector can become excessive.

### IF bandwidth

The IF bandwidth of the Service Monitor receiver circuits can be selected from the following options:

300 Hz	3.0 kHz	30 kHz	300 kHz
--------	---------	--------	---------

Press the *[IF Filter]* key. The right hand soft keys change, to allow selection of IF bandwidth filters as shown above.

The selected filter is shown on the display. Press the *[Return]* key after selecting the required filter.

### Audio frequency filtering

The demodulated signal can be filtered using high pass, low pass or band pass audio filters and with weighting filters as required.

Press the *[AF Filter]* key. The right hand soft keys change, to allow selection of AF filters as shown below. Press the *[Return]* key after selecting the required filter.

High Pass	Low Pass	Band Pass	CCITT <sup>†</sup> or C-MESS <sup>‡</sup>	Deemph
-----------	----------	-----------	---	--------

<sup>†</sup> Only if option 23 (CCITT filter) is fitted.

<sup>‡</sup> Only if option 24 (C-MESS filter) is fitted.

The high pass filter options are 50 Hz or 300 Hz.

There are five low pass filter soft keys. The 50 kHz LP filter can be considered to be the 'unfiltered' selection as this represents the normal full bandwidth of the audio circuits.

The other four low pass preset filters can each be set to any cut-off frequency within the range 250 Hz to 1.0 kHz and 3.0 kHz to 20.0 kHz.

The band pass preset filters can be customized by selecting either of the high pass options in combination with any of the four preset low pass filters.

The preset filters are set from the HELP/SETUP facility. The AF Filter setup [explanation](#) starts on page 3-11.

### De-emph

De-emphasis filtering, ON/OFF, is toggled by alternate presses of the *[Deemph]* key. The de-emphasis filtering uses a 750 μs time constant to give a 6 dB/octave roll-off.

De-emph ON appears on the main display when appropriate. No indication is given to show that de-emphasis is not on.

Press *[More]* to return to the previous menu or *[Return]* to display the main Tx TEST menu.

### \*OSCILLOSCOPE\*

The input to the oscilloscope is taken from the demodulators through any selected AF filters. Therefore modulation measurements made using the oscilloscope will include the characteristics of the selected AF filter.

### Audio distortion measurement

The Service Monitor is able to measure signal noise and distortion against the following parameters:

Signal to noise ratio	SINAD level	Percentage distortion
-----------------------	-------------	-----------------------

Press the *[Dist S/N]* key. The right hand soft keys change, to allow selection of S/N, SINAD and distortion measurements.

#### Off

Disables any active distortion measuring function.

*Hint. By disabling this function, the time taken to measure the remainder of the measurement functions is shortened thereby reducing the update time.*

#### S/N

Selects signal to noise ratio as the measurement method. The Signal to Noise bar chart ranges available are 0 to 30 dB and 0 to 100 dB. Signal to noise ratio is displayed as a digital read-out above the bar chart. The TX TEST mode menu is recalled automatically after pressing this key.

#### SINAD

Selects SINAD as the measurement method. The soft key displays the measurement frequency.

**The AF1 generator will be set to 1 kHz by this action, regardless of any previous setting.**

The distortion bar chart ranges available are 0 to 18 dB and 0 to 50 dB. The SINAD level is displayed as a digital readout above the bar chart. The TX TEST mode menu is recalled automatically after pressing this key.

#### Dist'n

Selects distortion percentage as the measurement method. The soft key displays the measurement frequency.

**The AF1 generator will be set to 1 kHz by this action, regardless of any previous setting.**

The distortion bar chart ranges available are 0 to 10%, 0 to 30% and 0 to 100%. The distortion percentage level is displayed as a digital readout above the bar chart. The TX TEST mode menu is recalled automatically after pressing this key.

With all the required parameters set, power up the transmitter.

The power output of the transmitter is shown on the POWER LEVEL bar chart, with the power level given in digital form above it.

The level of modulation is displayed on the modulation level bar chart, with the FM DEVN or the AM DEPTH shown digitally. When the SSB demodulation function has been selected, no modulation bar chart is displayed. The legend 'SSB Trans' and the selected sensitivity are shown.

The FREQ OFFSET will indicate the difference between the mean (measured) frequency of the transmission and that entered as transmitter frequency.

**More (FM deviation pk/rms, Inst dBr, dBr Ref, Abs Meas)**

Press the *[More]* key. The right hand soft keys change, to allow selection of the FM deviation and AM modulation measurement modes.

**FM Dev Pk/rms**

Toggles between measuring FM modulation with RMS or with peak detectors. The measurement mode – Pk or rms – appears to the left of the FM deviation bar chart.

**Inst dBr**

Pressing the *[Inst dBr]* soft key captures the current modulation level reading and enters it as the dBr reference level.

**dBr Ref**

Pressing the *[dBr Ref]* soft key allows a modulation reference level to be set, so that the digital modulation reading is shown as dBr levels relative to the reference. The bargraph readout and the positive and negative readings continue to display the absolute values.

The reference level can be set using the Data input keys or captured from the current absolute measurement by pressing the *[Inst dBr]* soft key.

**Abs Meas**

Pressing the *[Abs Meas]* soft key cancels the current dBr reference level and restores the digital modulation reading to absolute levels.

**More (Mod Pk Hld)**

Press the *[More]* key. The right hand soft keys change, to allow selection of modulation peak hold mode, where the highest received level is displayed. An inverse video red 'P' is displayed near to power readings that are peak-held. This also applies when the instrument performs duplex testing.

Press *[More]* repeatedly to cycle through the three sub-menus, or *[Return]* to display the main Tx TEST menu.

### Audio generator setup

Freq. range	5 Hz to 33 kHz
Level range	0.1 mV to 4 V rms
Shape option	Sine or square

To set up the audio generators in order to modulate the transmitter, press the *[Audio Gen]* key. This will display the audio setup menu shown in fold out diagram (2-4).

Set up the audio generator(s) for the required frequency and output level by using the soft keys and data input keys:

*[Gen 1/Gen 2]* to select AF1, then, *[FREQ][n]...[n][kHz/Hz]*

*[LEVEL][n]...[n][V/mV/dBm]*

then *[Gen 1/Gen 2]* to select AF2 if required, ...*[.../dBm]*

The FREQ [ $\uparrow$ ] and [ $\downarrow$ ] and the LEVEL [ $\uparrow$ ] and [ $\downarrow$ ] keys can be assigned to AF generator frequency and level. See *Incremental adjustments*, which starts on page 3-67.

Either or both generators can be switched off to suit the test requirement. To disable a generator select it using the *[Gen 1/Gen 2]* key to toggle between them. When the title of the generator is highlighted on the display, press the orange *[ON/OFF]* function key. Repeated presses of this key will toggle the ON/OFF action.

The shape of each audio generator output waveform can be either sine or square wave. This is controlled by first selecting the audio generator as for *[ON/OFF]* control above, then pressing the *[Shape]* key to toggle between the options.

**Note** that the audio generators are also used as modulation generators for the receiver test signal generator. If both generators are set up as a modulation source in the Tx test mode, switching to Rx TEST mode will show both modulation generators in the OFF condition. Either or both generators can be set up and turned on within the Rx TEST mode. The frequency, level and shape settings of their last use in the Rx TEST mode will be retained within the Rx TEST mode setup. These settings will be effective when the generators are switched to the 'ON' condition in receiver test mode. Their use as audio generators in the Tx TEST mode will then be disabled.

Pressing the *[Lock]* key locks the output level of the two audio generators to the same level. The unselected generator locks to the level of the selected generator.

When the audio generators are set to the required settings press the *[Return]* key to restore the Tx TEST menu.

## Making measurements

This section describes the actions needed to make measurements of each parameter associated with transmitter testing. All tests are described individually as ‘one off’ tests, but in practice, once set up, all active parameters will be measured simultaneously with continuous updating and the results displayed using the selected measurement units.

The results obtained from tests can be stored for later analysis or transfer to hard copy by making use of the internal setup/results memories. Test mode screen settings can similarly be stored for future use.

All of these features are described under *Stores*, *Settings/results*, or *Printer*, later in the chapter.

## Transmitter power

### Broad Band and Narrow Band power measurements

The monitor has both Broad Band and Narrow Band power measurement facilities. The Broad Band power meter measures the total average power of all signals present at either RF input, while the Narrow Band power meter measures only the average power of the signal contained within the IF pass band selected for the Tx TEST mode.

The facilities of the Service Monitor allow the RF signal generator to remain active in the Tx TEST mode. Therefore the signal from this will be present at common points within the RF input/output circuits of the instrument and will contribute to measurements made by the power meters. When making measurements where this will make any significant difference to the measurement, disable the RF generator by selecting the RF Gen OFF condition from the Rx TEST mode or the Dx TEST mode.

Narrow band power measurements cannot be made when the frequency of a transmitter has been set using the *[Auto Tune]* key.

The maximum continuous power rating of the ‘N-Type’ connector is 50 W with a minimum indication of 5 mW. Lower levels of input signal are indicated as voltage levels, the first bar chart graduation being at 20  $\mu$ V. The maximum continuous power rating of the antenna BNC connector is 5 W.

### CAUTION

**A power overload condition is indicated by an audible and visual warning. Should this condition be indicated, immediately reduce the level of RF power from the transmitter into the Service Monitor.**

**Do not stop the warning by switching off the Service Monitor, as this will silence the warning but will leave the excessive RF power connected to the internal load.**

**Do not attempt to stop the warning by disconnecting the RF connector, as this can damage the transmitter and may cause electric shock or skin burns.**



**WARNING**

**Hot surfaces**

Take care when touching the RF Input Type N connector after the application of high levels of continuous power. If 50 W is applied for a prolonged period, the temperature of the connector can become excessive.

With the monitor in the Tx TEST mode, and the transmitter connected to the monitor as described above, key up the transmitter.

The RF power bar chart gives an analog representation of the active power meter reading. A digital read-out of the power is displayed above the bar chart.

The options available for the digital read-out from the power meter are dBm, Watts or Volts.

The bar chart can be auto-ranging or manually selected. See [Bar charts](#) on page 3-19.

External attenuators can be included in the input path to the Service Monitor. The value of any such attenuators can be entered into the RF Setup page (page 3-15), which will cause the power measurement software to calculate the power at the attenuator input. The result of this calculation is shown on the RF power bar chart and as the digital power reading.

Power readings that include an attenuation factor have an inverse video 'A' adjacent to them.

An inverse video 'H' indicates that the receiver input is in held mode.

The full-scale ranges of the RF power bar chart are:

10 mW to 100 kW in 15 steps of 1-3-10 sequence.

100 mV to 3 kV in 16 steps of 1-3-10 sequence.

**External attenuators**

Compensation for an external attenuator or test fixture included in the RF input path of the monitor can be programmed. The value, in dBs, of the attenuator should be entered in the RF Power Ext Atten: field of the RF Setup page (page 3-15). The value of the attenuator will then be included in power calculations and the power indicated by the power meter will be that at the input to the external attenuator.

This feature makes use of the extended ranges of the power meter.

The value of the attenuator will also be included in RF level calculations and readouts when in the Rx TEST mode and in Dx TEST mode.

'A' is shown against any signal level that has been calculated to include the external attenuator.

**\*OSCILLOSCOPE\***

With the oscilloscope facility selected, the POWER bar chart is removed from the display but the digital read-out of the power level is retained.

**\*DUPLEX\***

With the monitor in the Dx TEST mode the POWER bar chart and digital display remain in the same location and the indications are identical to those given in the Tx TEST mode.

### Transmitter frequency

The digits adjacent to the Tx Freq legend on the Tx TEST display refer to the frequency to which the Service Monitor receiver circuits are tuned.

If the frequency of the transmitter is known, this figure can be entered manually. This is done by firstly pressing the *[Tx Freq]* key in the Tx TEST mode menu and then entering the figure using the data input keys. Complete the entry by use of the appropriate terminator key.

The receiver circuits of the monitor will then be tuned to that frequency and any signal within the IF pass band will be examined. The frequency difference between the set frequency and the true frequency will be displayed as 'offset'.

*Hint. When testing a transmitter using sequential tones, it may be necessary to pre-tune the Service Monitor receiver circuits in this way in order to successfully decode the initial tones.*

If the transmitter frequency is unknown, or it is to be measured, key up the transmitter and use the key sequence *[Tx Freq], [Autotune]*.

The receiver circuits of the monitor will then carry out a sweep to locate the signal and tune to it. The frequency of the signal is displayed against the Tx FREQ legend.

### **\*DUPLEX\***

The same frequency measurement procedures are applicable when in the Dx TEST mode.

### **RF distortion, and**

#### **Spurious outputs**

Distortion of the transmission RF output may be deliberate (modulation is a form of deliberate distortion), it may be due to a fault or because of design limitations. Whatever the reason the distortion produces harmonics or other spurious outputs.

These can be located using the SPEC ANA mode of operation.

By viewing the output signals from the transmitter on a voltage vs frequency plot, any transmissions outside the transmitter's specified bandwidth can be identified.

The use of the [SPEC ANA](#) mode is explained fully under that heading.

## Modulation characteristics

### Modulation frequency response and

#### Companding/limiting

The requirements of individual users will vary but the principle of the tests will be the same.

A signal having a known level and frequency is applied to the AF input of the transmitter and the level of modulation produced is measured.

To test the modulation characteristics of a transmitter with any degree of accuracy requires that the signal used to provide the modulation is accurately defined.

The Service Monitor has two AF generators for this purpose. The setting up instructions for frequency, level and shape options of these is given under '[Setting Up, AF Generators](#)' above.

The output from the AF generators is available at the AF output connector on the front panel. This signal should be used to modulate the transmitter, by direct connection to the AF input of the transmitter under test.

With the modulation meter options set to correspond with the modulation characteristics of the transmitter, the signal can be examined.

Modulation measurement with the Service Monitor is made using a method that evaluates the positive value and negative value as separate readings. This allows the results of both to be given on the display. The bar chart is a dual display indicating the positive value on the top bar and the negative value on the lower bar. The digital read-out is given in three parts. The normal size legend displays the P-P/2 modulation level, while the individual levels are given in half size numerals.

By making changes to the level of the applied AF signal, the linearity of the modulating circuits can be checked, limiting circuits, companders and voice activated switching circuits can be tested and adjusted.

The dual - positive and negative - readings are particularly useful when checking and adjusting the symmetry of transmitters.

Similarly, by repeating the tests at differing frequencies, the frequency response of the modulating circuits and filters can be plotted and adjusted.

By using both AF generators at different frequencies, or by using square wave output, intermodulation distortion levels can be explored and transient response examined.

#### **\*STANDARD OSCILLOSCOPE\***

The digital oscilloscope facility can be used for modulation testing. When this facility is active within the Tx TEST mode, the Service Monitor demodulator output is applied to the input of the oscilloscope.

The input to the oscilloscope is taken from the demodulators through any selected AF filters. Therefore modulation measurements made using the oscilloscope will include the characteristics of the selected AF filter.

The Y ranges of the oscilloscope are directly calibrated in deviation frequency when FM demodulation is selected and in percent modulation when AM demodulation is selected. The ranges are from 200 Hz/ Div. to 10 kHz/Div. in a 1, 2, 5, sequence and 25 kHz/ Div. FM and 5%, 10% and 20%/ Div. AM.

The X ranges are from 50  $\mu$ s/Div to 5 s/Div. in a 1, 2, 5, sequence.

When the oscilloscope facility is selected, the modulation level bar chart is removed from the display. The digital read-out of modulation level, including the positive and negative readings, is retained. The Modulation frequency digital readout is also retained.

#### **\*EXPANDED OSCILLOSCOPE\***

When the expanded oscilloscope is selected, all of the above relating to the standard oscilloscope apply *except* that the positive and negative modulation readings are not displayed.

**\*DUPLEX\***

All of the above information relating to modulation characteristics and frequency response testing also applies to tests made using the Dx TEST mode. The oscilloscope facility is not available when in Dx TEST mode.

**Modulation distortion**

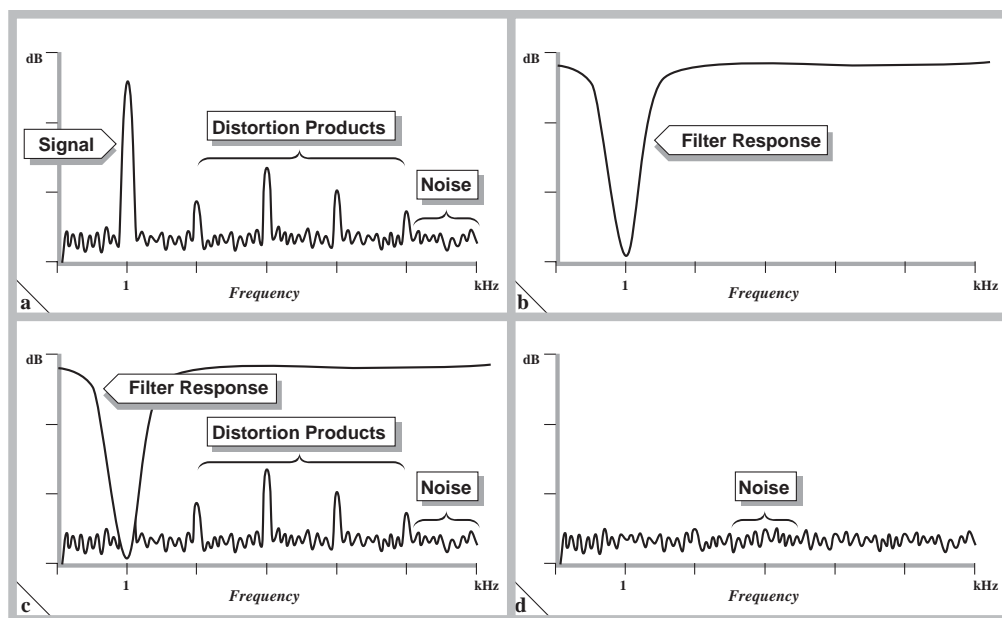

C1640

*Fig. 3-7 Distortion level and signal to noise level measurements*

The signal containing the information being communicated will become distorted during its progress through the system. This distortion may be very slight and almost unnoticeable to the ear or it may be so severe as to cause the information to become unintelligible.

The reasons for this distortion to the signal are the non-linearity of the amplifiers and modulators in the system, and noise within the circuits becoming attached to the signal.

By applying a sinewave signal of known purity to the input of the system and measuring the distortion and noise levels of the demodulated signal obtained at the output of the system, evaluation of the quality of the transmitter is possible.

The three measurements used for this evaluation are SINAD level; distortion percentage; and signal to noise ratio.

The procedures described below are carried out repeatedly under the instruction of the instrument software and the displayed results are continually updated.

To obtain the SINAD level of a signal at the output of a transmitter the output level is measured and noted.

The signal measured comprises the value of the fundamental signal, the values of any distortion products generated and the value of any noise present.

A notch filter tuned to the frequency of the input signal is then placed in the output signal path and the level again measured and noted. The second measurement comprises only the values of any distortion products generated and the value of any noise present. See page 3-36, Fig. 3-7 a, b, & c, *Distortion level and signal to noise level measurements*.

The SINAD level is then calculated according to the formula:

$$\begin{aligned} \text{SINAD} &= 20 \log \frac{V_1}{V_2} \text{ dB} \\ &= 20 \log \frac{(S + N + D)}{(N + D)} \text{ dB} \end{aligned}$$

To obtain the distortion factor of a signal at the output of a transmitter the output level is measured and noted as for SINAD level measurement.

A notch filter as used for SINAD measurement is used to make a second reading, which comprises the same values as for the second SINAD measurement.

The distortion factor is then calculated according to the formula:

$$\begin{aligned} \text{Distortion} &= 100 \frac{V_2}{V_1} \% \\ &= 100 \frac{(N + D)}{(S + N + D)} \% \end{aligned}$$

For signal to noise level measurements a reading is taken of the output level as for SINAD level and distortion factor measurements. The AF input signal is then disabled and a second level reading taken. A notch filter is not included in the signal output path. The second measurement only comprises the value of any noise present on the demodulated signal. See page 3-36, Fig. 3-7 a, & d, *Distortion level and signal to noise level measurements*.

The signal to noise level is then calculated according to the formula:

$$\begin{aligned} \text{S/N} &= 20 \log \frac{V_1}{V_2} \text{ dB} \\ &= 20 \log \frac{(S + N + D)}{N} \text{ dB} \end{aligned}$$

The distortion measuring system within the Service Monitor has the capability to make all three measurements. Pressing the *[Audio Meter]* key, to change the soft keys as shown in fold out diagram (3-3), then pressing the *[Dist/S-N]* soft key, accesses the distortion measurement menu shown in fold out diagram (3-3-2).

The action of selecting a measurement system returns the TRANSMITTER TEST main (top level) menu to the display.

The result of the selected measurement will be displayed on a bar chart within the transmitter test screen and a digital read-out given above it. When no distortion measurement system is selected, by pressing the *[Off]* key within the distortion measuring menu, the distortion bar chart and digital read-out are removed from the screen.

*Hint. By disabling this function, the time taken to measure the remainder of the measurement functions is shortened thereby reducing the update time.*

Measurements of SINAD and distortion percentage carried out by the monitor use a frequency of 1 kHz for the tests. When either of these test methods is selected, the system software sets the frequency of the modulation generator to this frequency to avoid erroneous results.

The input signal level influences the readings obtained by the distortion measuring system and is usually specified as part of the test specification.

**\*OSCILLOSCOPE\***

With the oscilloscope facility selected, the distortion level bar chart is removed from the display but the digital read-out is retained.

**\*DUPLEX\***

When in the Dx TEST mode, modulation distortion tests are not displayed.

## Rx test (receiver testing)

### Overview

The Communications Service Monitor has been designed to test the performance of mobile communication equipment. This section explains the use of the Rx TEST mode. Typical uses are:

- Performance checking following manufacture
- Routine quality assurance testing
- Workshop or field fault diagnosis etc.

The tests that need to be carried out will depend on the specification of the receiver and the reason for testing, however a generalized list would be:

Sensitivity
AF Bandwidth
AF Distortion
Selectivity
Blocking (or desensitization)
Spurious response
AGC response

With the Rx TEST mode selected, the screen and menu shown in fold out diagram (3-0) is displayed.

From this screen and menu, the setting up of the inbuilt devices for receiver testing, and the read out of results is carried out.

The sections of the monitor available for receiver testing are:

RF signal generator.

Audio modulation generators. Used to provide modulation of the RF generator.

Audio tone generator. Provides tones for CTCSS, Sequential, DTMF systems.

Audio distortion meter

Digital oscilloscope

As well as setting up the major sections of the Service Monitor, the selection of the following parameters are selected from the RECEIVER TEST screen:

Audio filters

Pre-emphasis filtering

Selection of distortion measuring methods.

Connections

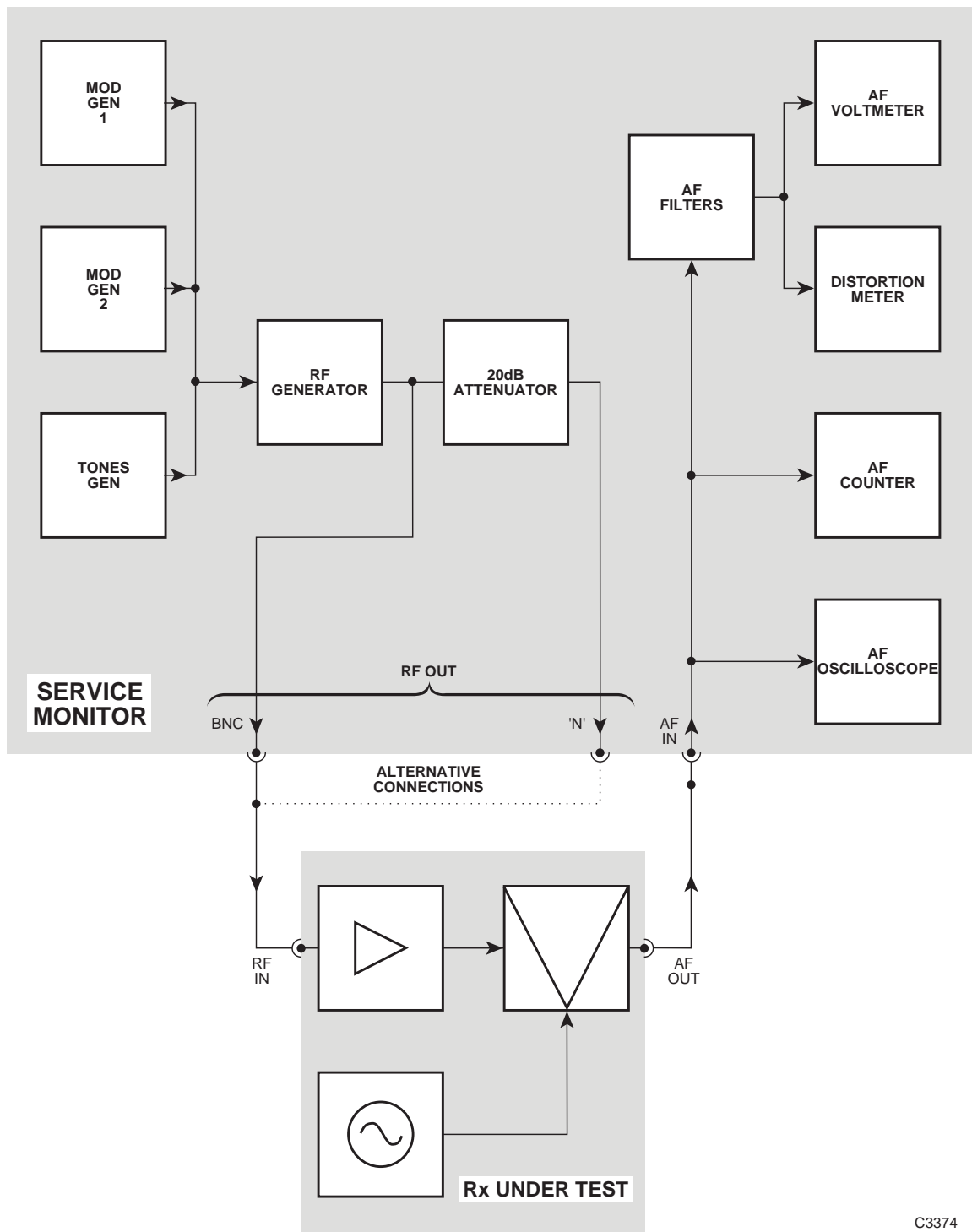

C3374

Fig. 3-8 Receiver test connections

Before making any connections between the Service Monitor and the receiver ensure that the RF generator of the Service Monitor is OFF. With the Rx TEST mode selected, press [RF Gen] key to highlight the GEN FREQ legend. Pressing the orange [ON/OFF] function key will change the state of the RF generator. OFF is shown adjacent to the indicated generator frequency when the RF generator is disabled.

The RF generator settings can be changed with the generator ON or OFF.

When testing the receiver section of a transceiver, ensure that the power output of the transmitter section will not exceed the power handling capability of the connector on the Service Monitor. Also ensure that the transceiver cannot be switched to 'TRANSMIT' inadvertently.

The receiver and the Service Monitor should be connected as shown in Fig. 3-8 *Receiver test connections*. The block diagram of the Service Monitor shows the signal routing within it.

Points to note are:

The power source for the receiver should be reliable and stable. The battery of a vehicle may discharge if supplying a mobile transceiver during prolonged testing or the earth connection may become open circuit if the transceiver is removed from its normal location.

When testing the receiver section of transceivers take precautions to prevent the inadvertent 'keying' of the transmitter.

The RF input connection to the receiver should be made using good quality RF cable with correctly fitted connectors. Worn connectors and damaged or kinked cable can produce reflections and losses in the system, which will give misleading results.

## Setting up

When all the required connections have been made, select the Rx TEST mode to display the screen shown in fold out diagram (3-0).

Set the parameters or options to suit the test requirements from the RECEIVER TEST menus.

### Rx frequency

Range	400 kHz to 1.05 GHz
-------	---------------------

Press the [RF Gen] key.

The GEN FREQ legend is highlighted as shown in fold out diagram (3-1).

If the Rx=Tx function has been set from the Tx TEST mode, the GEN FREQ will be set to the receiver frequency relevant to that test. If this is correct for the receiver under test, there is no need to re-enter the frequency.

### Manual frequency setting

With GEN FREQ legend highlighted, data may be entered from the keyboard to the GEN FREQ parameter. Enter the required frequency by using the digit keys and the decimal point key if relevant. The resolution of the RF generator frequency entry is 1 Hz, but it is not necessary to enter every digit down to the least significant place.

The entry is completed by pressing a terminator key. Using the [MHz], [kHz] or [Hz] key causes the entered frequency to be displayed according to normal convention. The following examples explain further.

Pressing:

[1] [2] [5] [MHz]	will display	125.000000 MHz
[1] [2] [5] [kHz]	" "	125.000 kHz
[1] [2] [5] [0] [kHz]	" "	1.250000 MHz
[1] [.] [2] [5] [MHz]	" "	1.250000 MHz
[1] [2] [5] [0] [0] [0] [1] [Hz]	" "	1.250001 MHz

### Variable control

With the GEN FREQ legend highlighted, the GEN FREQ parameter can be adjusted by using the variable control.

### Frequency increment

The FREQ [↑] and [↓] keys can be assigned to RF generator frequency adjustment. See *Incremental adjustments*, which starts on page 3-67.



## Output level setting

Range	
N-Type connector,	-135 dBm to -15 dBm; 0.04 mV to 40 mV pd
BNC connector,	-115 dBm to +5 dBm; 0.4 mV to 400 mV pd (with uncalibrated overrange to +7 dBm)

### WARNING

## Hot surfaces

Take care when touching the RF Input Type N connector after the application of high levels of continuous power. If 50 W is applied for a prolonged period, the temperature of the connector can become excessive.

The signal generator output level is set using the data keys. It can be defined in dBm with the [dBm] terminator key, by voltage level with the [V], [mV] or [ $\mu$ V] terminator key or in dB $\mu$ V with the [dB] key.

Voltage levels and dB $\mu$ V levels will be shown as PD or EMF, depending on the selection made on the RF Setup page (page 3-15). The output range from each connector is given in the *Performance data* section of Chapter 1.

The signal generator output level from the BNC connector is calibrated up to +5 dBm. The output level can be increased to approximately +7 dBm, uncalibrated.

Note that any external attenuator values entered on the RF Setup page will reflect in the level of indicated output. If an external attenuator value is currently set, output levels which have been modified to take account of the additional attenuation will be indicated on the display by  $\Delta$  against them. See *RF Power Ext Atten : dB*, on page 3-15.

To enter an output value press the [RF Gen] key, followed by the orange [LEVEL] function key. The GEN and LEVEL legends will be highlighted.

Enter the required value using the data entry numeric keys and the relevant terminator key. The level will be displayed in correct engineering convention.

## Variable control

With the GEN and LEVEL legends highlighted, the GEN LEVEL parameter can be adjusted by using the variable control.

## Level increment

The LEVEL [ $\uparrow$ ] and [ $\downarrow$ ] keys can be assigned to RF generator level adjustment. See *Incremental adjustments*, which starts on page 3-67.

## Attenuator hold

The Service Monitor has an attenuator hold facility that allows for a 'seamless' range of RF output level. This has a minimum range of 10 dB with a maximum range of 20 dB at certain selected points of the output range. The facility is enabled and set from the AF Setup page (page 3-17).

## Modulation

The RF signal generated for receiver testing can be modulated using either or both of the AF generators or by an external source.

## Modulation type

The modulation type is automatically set, to be appropriate to the level terminator key used (FM for Hz, kHz or MHz; AM for %).

### Modulation generators

Set up one or both of the modulation generators for the required frequency, level and shape by using the soft keys and data input keys. When these and the de-emphasis filter are set to the required settings press the *[Return]* key to restore the RECEIVER TEST menu.

### Modulation frequency and level

The frequency range and level must not exceed the following limits:

Modulating freq. range	20 Hz to 20 kHz.
AM depth range	0 to 99% total sum of active modulation sources.
FM deviation range	0 to 75 kHz total sum of active modulation sources.

To enable or set up the modulation generators press the *[Mod Gen]* key. The screen and menu shown in fold out diagram (4-2) will be displayed.

Set up the modulation generator(s) for the required frequency and output level by using the soft keys and data input keys:

*[Gen 1/Gen 2]* to select MOD1, then, [FREQ][n]...[n][kHz/Hz]  
 [LEVEL][n]...[n][kHz/Hz]  
 then *[Gen 1/Gen 2]* to select MOD2 if required,....[.../Hz]

### Frequency and level increment

The FREQ [ $\uparrow$ ] and [ $\downarrow$ ] and the LEVEL [ $\uparrow$ ] and [ $\downarrow$ ] keys can be assigned to the modulation generator frequency and level. See *Incremental adjustments*, which starts on page 3-67.

### Modulation generator state

Either or both generators can be switched off to suit the test requirement. To disable a generator, first select it using the *[Gen 1/Gen 2]* key. Repeated presses of the orange [ON/OFF] function key will disable or enable the selected generator.

**Note** that the modulation generators are also used as AF generators to provide a modulation source in the Tx TEST mode.

If both AF generators are set to ON in the Tx TEST mode, switching to Rx TEST mode will show both modulation generators to be OFF.

Either or both generators can be set up and turned on within the Rx TEST mode.

The frequency, level and shape settings of their last use in the Rx TEST mode will be retained within the Rx TEST mode setup. These settings will be effective when the generators are switched to ON in the Rx TEST mode. Their use as audio generators in the Tx TEST mode will then be disabled.

### Modulation generator shape

The shape of the output waveform from each modulation generator can be set to either sine or square wave. To change the output waveform from a generator, first select it using the *[Gen 1/Gen 2]* key. Repeated presses of the *[Shape]* key will toggle between sine or square wave.

### Modulation generator level locking

Pressing the *[Lock]* key locks the output level of the two modulation generators to the same level. The unselected generator locks to the level of the selected generator.

### Pre-emphasis filter

The pre-emphasis filter can be switched in or out of circuit after pressing the *[Mod Gen]* key.

Pressing the *[Pre-emph]* key will toggle the pre-emphasis filter into and out of circuit. The time constant of the filter is 750  $\mu$ s, giving an increase with frequency of 6 dB/octave.

The legend Pre-emph ON is displayed when the filtering is in circuit. No indication is given when the filtering is out of circuit.

### External Modulation

An external modulation source may be used to modulate the RF generator signal. Pressing the *[Ext Mod]* key will display the external modulation input selection menu.

The options available are:

[DC Ext]	Selects the 'EXT MOD IN' connector on the rear of the instrument, with DC coupling.
[AC Ext]	Selects the 'EXT MOD IN' connector on the rear of the instrument, with AC coupling .
[Mic]	Selects Microphone (connected to the ACCESSORY socket on the front panel) as the external modulation source.

The selection is shown on the display next to the Ext Level Source legend. The frequency range for each input option is specified in the *Performance data* section of Chapter 1.

The level of the external modulation signal should be 1.0 V rms. This retains correlation of the modulation level indicated on the display with that applied to the RF signal.

### Setting external modulation level

Press the *[Ext Mod]* key, which as well as displaying the menu mentioned above, will highlight the **EXT LEVEL** legend. Use the data input keys to set the required level, followed by the appropriate [Hz], [kHz] or [%] key.

*Hint. The modulation source level can be measured using the AF INPUT connector on the front panel and AF LEVEL bar chart, or by monitoring the modulation level of the RF generator using the Dx TEST mode.*

### Microphone input

A microphone suitable for connecting to the accessory socket, is available as an optional accessory. See *Options and accessories*, in the *Performance data* section of Chapter 1.

The microphone input circuit contains a limiter to prevent over-modulation, and the external modulation level setting remains effective when the microphone option is selected. This gives versatility of test options to suit the user's requirements.

The microphone input must be selected to make use of the PTT switching facility available in the Tx TEST mode.

The level of the modulation from the external source will add to the level of any internal modulation and will therefore be included in the total sum of modulation sources.

The state of the external modulation source can be changed by pressing the orange [ON/OFF] function key when the **EXT LEVEL** legend is highlighted. Off is displayed next to the external modulation parameters when the external modulation is disabled.

**Note** that only one type of modulation can be applied to the RF signal. For example:

If the [%] terminator key is used to complete a modulation setting when an FM deviation level is already set from another source, the latest selection will cause the previous setting to be cancelled.

## AF input level measurement

The measured level of signals applied to the AF INPUT connector can be displayed in volts, dBm, dBV or mW. The selection is made from the AF Setup page, as described under [Audio Level Measured in:](#) on page 3-17. When the input level is displayed in dBm or mW, the signal is assumed to be measured across 600 Ω.

The 600 Ω interface unit allows the Service Monitor to provide a 600 Ω termination. (See [Audio Input Impedance](#) on page 3-17.) With the input impedance set at 600 Ω, the indicated level is that of the input to the Service Monitor. With the input impedance set at High, the indicated level is that of the input to the Service Monitor with an assumed 600 Ω load.

## AF filters

The AF signal to the AF INPUT connector on the front panel can be filtered using high pass, low pass or band pass audio filters and with weighting filters as required.

Press the *[Audio Meter]* key, followed by the *[AF Filter]* key. The left hand soft keys change, to allow selection of AF filters as shown below. Press the *[Return]* key twice after selecting the required filter.

High Pass	Low Pass	Band Pass	CCITT <sup>†</sup> or C-MESS <sup>‡</sup>
-----------	----------	-----------	--

<sup>†</sup> Only if option 23 (CCITT filter) is fitted.

<sup>‡</sup> Only if option 24 (C-MESS filter) is fitted.

The high pass filter options are 50 Hz or 300 Hz.

There are five low pass filter soft keys. The 50 kHz LP filter can be considered to be the ‘unfiltered’ selection as this represents the normal full bandwidth of the audio circuits.

The other four low pass preset filters can each be set to any cut-off frequency within the range 250 Hz to 1.0 kHz and 3.0 kHz to 20.0 kHz.

The band pass preset filters can be customized by selecting either of the high pass options in combination with any of the four preset low pass filters.

The preset filters are set from the HELP/SETUP facility. The AF Filter setup [explanation](#) starts on page 3-11.

## \*OSCILLOSCOPE\*

The input to the oscilloscope is taken directly from the AF input connector on the front panel, not through any of the AF filters. Therefore measurements obtained on the AF voltmeter will show the effects of filtering, whereas those made using the oscilloscope will not.

## Audio distortion

The Service Monitor is able to measure signal noise and distortion against the following parameters:

Signal to noise ratio	SINAD level	Percentage distortion.
-----------------------	-------------	------------------------

Distortion levels introduced into the audio signal path can be measured using the distortion measuring module.

Pressing the *[Audio Meter]* key, to change the soft keys as shown in fold out diagram (3-3), then pressing the *[Dist/S-N]* soft key, accesses the distortion measurement menu shown in fold out diagram (3-3-2). The function of each soft key on this menu is as follows:

**Off**

Disables any active distortion measuring function and removes the distortion bar chart from the display.

*Hint. By disabling this function, the time taken to measure the remainder of the measurement functions is shortened thereby reducing the update time.*

**S/N**

Selects Signal to noise ratio as the measurement method. Compares the level of the demodulated signal together with the system noise, against the level of the system noise only, using the formula:

$$\begin{aligned} \text{S/N} &= 20 \log \frac{V_1}{V_2} \text{ dB} \\ &= 20 \log \frac{(S + N + D)}{N} \text{ dB} \end{aligned}$$

See Fig. 3-7 a, & d, *Distortion level and signal to noise level measurements*, on page 3-36. The distortion bar chart is graduated in dB and is also displayed as a digital read-out above the bar chart. The Rx test menu is recalled automatically after pressing this key.

**Sinad**

Selects SINAD as the measurement method. The modulation generator is set to 1 kHz. By filtering the demodulated signal with a 1 kHz notch filter and comparing the result with the unfiltered signal, the SINAD level is established using the formula:

$$\begin{aligned} \text{SINAD} &= 20 \log \frac{V_1}{V_2} \text{ dB} \\ &= 20 \log \frac{(S + N + D)}{(N + D)} \text{ dB} \end{aligned}$$

See Fig. 3-7 a, b, & c. *Distortion level and signal to noise level measurements*, on page 3-36. The distortion bar chart is graduated in dB and the SINAD level is displayed as a digital readout above the bar chart. The Rx test menu is recalled automatically after pressing this key.

**Dist'n**

Selects distortion percentage as the measurement method. The modulation generator is set to 1 kHz. By filtering the demodulated signal with a 1 kHz notch filter and comparing the result with the unfiltered signal, the distortion percentage level is established by the formula:

$$\begin{aligned} \text{Distortion} &= 100 \frac{V_2}{V_1} \% \\ &= 100 \frac{(N + D)}{(S + N + D)} \% \end{aligned}$$

See Fig. 3-7 a, b, & c. *Distortion level and signal to noise level measurements*, on page 3-36. The distortion bar chart is graduated in % and the distortion percentage level is displayed as a digital readout above the bar chart. The RX TEST menu is recalled automatically after pressing this key.

### **Audio peak hold**

Press the *[Audio Meter]* key, followed by the *[Audio Pk Hld]* key.

The highest transmitted audio level is held on the display. An inverse video red 'P' is displayed near to power readings that are peak-held, in receiver, duplex and audio screens.

### **Instrument dBr level, dBr ref**

Press the *[Audio Meter]* key, followed by the *[More]* key.

#### **Inst dBr**

Pressing the *[Inst dBr]* soft key establishes the current modulation level reading as the dBr reference level.

#### **dBr Ref**

Pressing the *[dBr Ref]* soft key allows a modulation reference level to be set, so that the digital modulation reading is shown as dBr levels relative to the reference. The bargraph readout and the positive and negative readings continue to display the absolute values.

The reference level can be set using the Data input keys or captured from the current absolute measurement by pressing the *[Inst dBr]* soft key.

#### **Abs Meas**

Pressing the *[Abs Meas]* soft key cancels the current dBr reference level and restores the digital modulation reading to absolute levels.

## Making measurements

(Examples of receiver tests).

The procedure for making each of the tests listed in the receiver testing overview, above, follows. Some of the tests may require separate operations and others will only require a reading to be made.

### Sensitivity

Receiver sensitivity is defined as the minimum RF level required at the antenna to produce an intelligible output of the modulated information.

The problem with the above definition is that of defining 'intelligible output'. As this is a subjective decision, sensitivity specifications require certain parameters to be set down. The nature of FM and phase transmissions makes sensitivity measurements less straightforward than with AM transmissions. A sensitivity test on an AM receiver can be stated as 'X watts audio output from Y  $\mu$ V RF input at Z% modulation'.

As there is no direct/linear relationship between RF signal level and audio output with FM receivers, most manufacturers normally quote receiver sensitivity in one of the following four ways:

12 dB SINAD sensitivity.

20 dB weighted SINAD sensitivity.

20 dB signal to noise sensitivity.

20 dB quieting sensitivity.

When defined as part of a specification, the sensitivity will be given in the form:

'Sensitivity (12 dB SINAD) 0.25  $\mu$ V'

or

'Sensitivity (20 dB SINAD) 1.0  $\mu$ V EMF'

or

'12 dB (minimum) SINAD for 0.31  $\mu$ V (pd) signal input (at 60% of maximum system deviation and 1 kHz modulation).'

The test method for each of the above sensitivity specifications varies, but the common features are that each requires a signal of accurately defined level, modulation frequency and modulation level to be injected into the receiver, the AF output level referenced, the modulation or a portion of it, to be removed and the audio level re-referenced.

To carry out each of these tests using Service Monitor proceed as follows:

#### 12 dB SINAD sensitivity

This test determines the level of the modulated RF signal at which the SINAD measurement is 12 dB. The level of modulation is given as part of the test specification. The standard modulation frequency is 1 kHz.

As the RF signal level is reduced, the 'noise' component of the AF output will become proportionally greater. This will result in the SINAD dB reading becoming closer to zero.

To use this Service Monitor to make a 12 dB SINAD sensitivity test, the Service Monitor is set up to make a SINAD distortion measurement and the RF level progressively reduced until the SINAD level reads 12 dB. The RF level of the signal generator will equal the 12 dB SINAD sensitivity level of the receiver.

For a GO/NO GO test the monitor is set up in the same manner as above. The RF level is set to the specified sensitivity level and the SINAD distortion level observed. A reading higher than 12 dB would indicate GO, while a reading of less than 12 dB (i.e. closer to zero) would indicate NO GO.

### 20 dB weighted SINAD sensitivity

This test is very similar to the 12 dB SINAD sensitivity test

The differences are firstly that the SINAD level specified is 20 dB and secondly that a psophometric weighting filter is included in the test path. This filter imposes a frequency response characteristic to the signal similar to that of the human ear response.

There are two specifications of filter in common use. One is the European standard CCITT and the other is the American C-MESS. The specification of the receiver will state the correct filter to select.

The Service Monitor can have a filter meeting one of these specifications fitted as an option.

The test procedure is identical to that for 12 dB SINAD sensitivity except that the SINAD distortion pass level is 20 dB.

### 20 dB signal to noise sensitivity

This test determines the level of RF carrier which, when unmodulated will produce an AF output level due only to receiver noise, 20 dB below the AF level produced when modulated at the specified level and at the specified frequency.

As the RF signal level is reduced, the 'noise' component of the AF signal will become proportionally greater. This will result in the Signal to Noise dB reading becoming closer to zero.

To use this Service Monitor to make a 20 dB S/N sensitivity test, it is set up to make signal to noise measurements through the distortion meter menu of the Rx TEST mode. The modulation frequency and level are set according to the receivers test specification requirements.

The RF level is adjusted until the S/N level indicated on the Service Monitor reads 20 dB. The RF level will then equal the 20 dB S/N sensitivity level.

For a GO/NO GO test the monitor is set up in the same manner as above. The RF level is set to the specified sensitivity setting and the S/N level observed. A reading higher than 20 dB would indicate GO, while a reading of less than 20 dB (i.e. closer to zero) would indicate NO GO.

### 20 dB quieting sensitivity

This test determines the level of unmodulated RF signal that will produce an AF output from the receiver that is 20 dB lower than the noise level from the receiver when no carrier is being received.

The reduction in AF output when a carrier is being received is due to the action of the automatic gain control circuits in the RF amplifiers of the receiver.

The gain of the receiver will reduce as the level of the RF signal increases. Therefore the noise level will decrease with an increase in RF signal level.

To use this Service Monitor to make a 20 dB quieting sensitivity test the unmodulated RF signal is applied to the receiver at the frequency called for in the test specification. If no frequency is specified, a convenient mid band frequency is selected.

Select *[RF Gen]* from the soft key options. Turn the RF signal off by use of the orange [ON/OFF] function key and note the indicated AF level.

Turn the RF signal ON and adjust the RF level until the indicated AF level is 20 dB less than the previously noted level. The indicated RF level is the 20 dB quieting sensitivity level of the receiver.

For a GO/NO GO test proceed as above until the AF level with no RF input is noted. Then turn the RF signal on and adjust the RF level to the figure specified as the 20 dB quieting sensitivity level. Now observe the AF level indication. A reading greater than 20 dB will indicate GO. A reading lower than 20 dB, (i.e. closer to zero), will indicate NO GO.



### Basic sensitivity test

To carry out a basic sensitivity test on an AM receiver:

Set the RF generator frequency to that required by the test program. This setting can be entered using the data input keys or set using the Rx=Tx facility discussed under Tx mode. The RF generator can be switched off during the setup operation if required, by pressing the orange [ON OFF] function key.

Select [*Mod Gen*] from the RECEIVER TEST screen.

Set the modulation frequency and level. It is usual to use a single sinewave tone when carrying out sensitivity tests and essential for SINAD tests.

Select the 'pre-emphasis' facility if required, by pressing the [*Pre-emph*] key.

Return to the RECEIVER TEST screen and select the 'AF filter' menu ([*Audio Meter*] key). Select the required AF filtering.

Return to the RECEIVER TEST screen and adjust the RF output level to that required by the test specification.

Switch the RF generator output ON by pressing the orange [ON OFF] function key.

The audio output from the receiver is measured and the level and frequency displayed.

For measuring sensitivity levels, rather than checking against settings, the various parameters on the monitor can be adjusted in steps using the LEVEL [ $\uparrow$ ] and [ $\downarrow$ ] keys, or by precision adjustment using the variable control.

### AF bandwidth

The audio bandwidth of a receiver should be complementary to that of the transmitter or transmitters associated with it.

The test for audio bandwidth is made by establishing a reference frequency, usually 1 kHz, and reference level, then varying the modulating frequency until the measured audio output level reduces by 3 dB. The 3 dB points above and below the reference frequency will be the limits of the AF bandwidth.

When carrying out audio bandwidth tests the monitor audio filtering should be set to the widest possible, i.e. 50 kHz.

Note that most FM transceivers apply pre-emphasis filtering to the transmitter modulation and de-emphasis filtering to the demodulated signal.

### AF distortion

The two methods used for quoting distortion within radio receivers are Distortion Factor and SINAD.

SINAD tests are usually made in conjunction with sensitivity testing (see above), while distortion test results are often quoted within the power output parameter. For example '3 Watts output with better than 10% THD' (total harmonic distortion).

The signal to noise level is also quoted but is a measure of receiver quality, not a true measure of distortion.

The AF distortion measuring facility performs continuous reading and display metering using the selected function, (SINAD or distortion factor). Therefore a distortion test can be carried out by ensuring that the RF generator is tuned to the correct frequency, select the distortion measuring function required and set the levels of the RF and AF generators. The distortion factor or SINAD level is then read from the screen.

To obtain sets of readings relating to differing levels of RF or AF, the levels are reset and the new reading made.

Selectivity

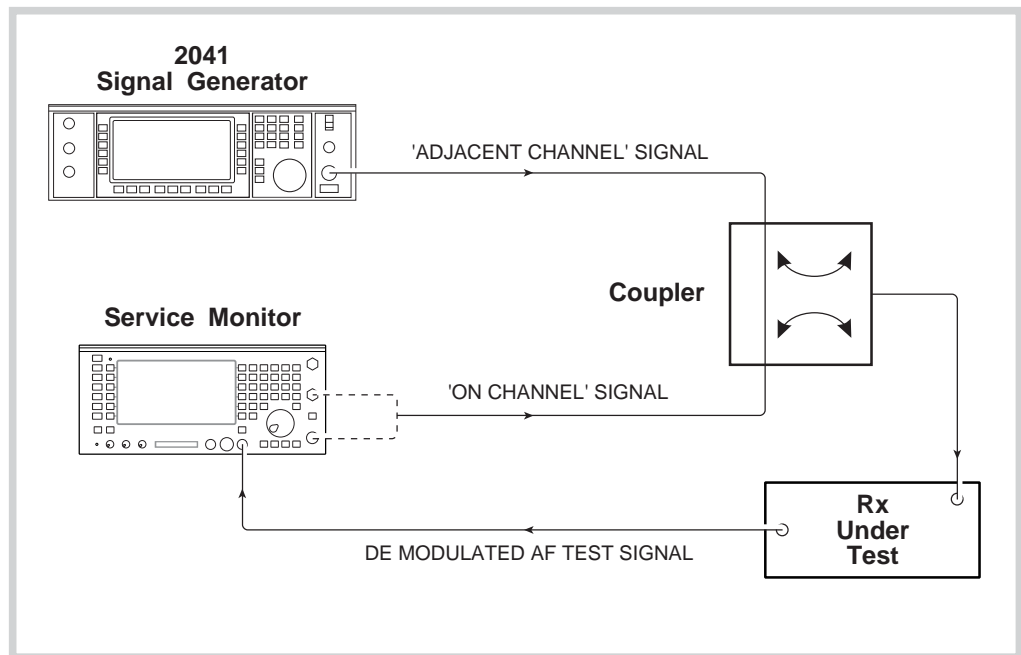

C3375

Fig. 3-9 Selectivity test setup

Selectivity tests are measurements of the capability of a receiver to differentiate between a wanted signal and an unwanted signal, usually that transmitted on an adjacent channel.

This test is carried using the Service Monitor as for previous tests but with a second RF signal generator simulating the adjacent channel transmitter. See Fig. 3-9, *Selectivity test setup*, on page 3-50.

A specification for receiver selectivity requires parameters to be set down to measure against. Within the specification of a typical mobile radio a typical adjacent channel selectivity figure might read: '12 dB adjacent channel selectivity; better than 80 dB', and the 20 dB weighted SINAD sensitivity is quoted as 'better than 1  $\mu$ V'.

To confirm this selectivity figure proceed as follows:

The equipment is connected as in Fig. 3-9, *Selectivity test setup*. The level of modulation for the 'wanted' signal is set to 60% of the maximum deviation for FM receivers or 30% modulation for AM receivers. The modulation frequency is 1 kHz unless specified differently.

The generator being used to provide the adjacent channel signal is set to the frequency of the adjacent channel with a modulation frequency of 400 Hz unless specified differently. The modulation level is set to 60% of the maximum deviation for FM receivers or 30% modulation for AM receivers. The carrier is switched off at the commencement of the test.

The level of the Service Monitor providing the 'wanted' signal is adjusted until a SINAD reading of 20 dB is obtained as for sensitivity testing. The RF output level of the generator should be noted. This should be the same level as that established in the 20 dB sensitivity test (above).

The carrier from the signal generator providing the 'adjacent channel' signal is switched on and the level of its output increased until the SINAD level is reduced to 12 dB. The RF output level should be noted.

The difference in output level of the two RF generators, expressed in dB, is the '12 dB Adjacent Channel Selectivity' level.

In the example above, with a 'wanted' signal level of -90 dB and a 'adjacent' signal level of -7 dB, the performance of the receiver would be satisfactory. If the 'adjacent' signal level was found to read -13 dB the performance of the receiver would be below specification.

### Blocking (or desensitization)

Blocking (or desensitization) is an undesirable response by a receiver to a signal whose frequency is spaced from the wanted signal by a frequency difference greater than the adjacent channel spacing. The interfering signal will enter the IF pass band of the receiver with sufficient strength to cause the automatic gain control to operate. This will reduce the gain of the receiver and ‘block out’ weak signals.

The test setup is the same as for selectivity testing.

The generator being used to provide the ‘wanted’ signal is set as for selectivity testing and the level adjusted to produce a SINAD level of 20 dB.

The generator providing the ‘interfering’ signal should be unmodulated and set to an RF level of between 80 and 90 dB above the level of the ‘wanted’ signal

The frequency of the ‘Interfering’ signal should be slowly swept over a range of 1 to 10 MHz either side of the ‘wanted’ signal frequency and the SINAD level observed for any significant variation. If any interaction is found, adjust the frequency of the ‘interfering’ signal for maximum reaction. Vary the level of the ‘interfering’ signal until the SINAD level is 14 dB and note the RF level. This is the blocking level of the receiver for the frequency concerned.

### Spurious response

The two types of spurious response measurements normally carried out on a receiver are image frequency rejection and IF rejection.

For a specific receiver type, the frequency of the image signal of a ‘wanted’ signal is twice the receiver intermediate frequency above the wanted frequency if the receiver local oscillator runs at a frequency above the wanted signal, or twice the receiver intermediate frequency below the wanted frequency if the receiver local oscillator runs at a frequency below the wanted signal. See Fig. 3–10, *Spurious response ‘Image Frequency’ location*.

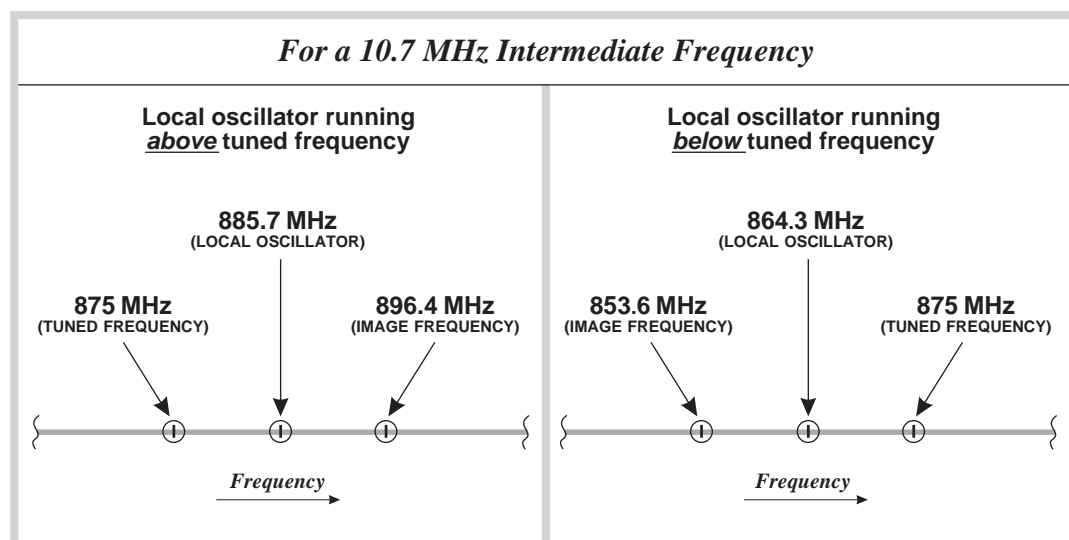

C1614

Fig. 3–10 Spurious response ‘Image Frequency’ location

With the receiver and Service Monitor set up as for sensitivity testing, establish a reference RF input level. Change the RF output frequency of the Service Monitor to the image frequency of receiver tuning point, without altering the receiver tuning. Increase the RF output level of the Service Monitor RF generator until the SINAD level reads 20 dB and note the RF level. The difference in the level of the RF generator readings for the two frequencies, expressed in dB, is the ‘image frequency rejection ratio’.

The procedure for measuring the IF rejection ratio is similar to that used to measure image frequency rejection and uses the same setup. The RF reference level is found at the RF frequency to which the receiver is tuned, then the RF generator is retuned to the IF frequency of the receiver under test. The RF output level is increased until a 20 dB SINAD level is obtained. The output level of the RF generator is noted. The difference in level of the RF generator readings, expressed in dB, is the 'IF rejection ratio' of the receiver.

### **AGC response**

Automatic Gain Control is used in AM receivers to stabilize the level of the audio output signal against changes in the level of RF input. This is necessary as the output voltage from the detector circuit with a constant % depth of modulation is proportional to the level of the RF signal applied to the detector.

To plot the AGC response of a receiver, set up the instrument and receiver as described for receiver audio frequency response tests. The test can be made at one RF frequency only or at various points throughout the receiver tuning range. This will depend on the reason for making the test and the specification of the receiver.

Set the RF generator frequency of the Service Monitor to the selected tuning point of the receiver with the modulation level set to 30% at 1 kHz. Increase the RF output level until an AF output is registered on the Service Monitor display, either bar chart or oscilloscope.

Reduce the RF output level until the AF output level of the receiver reaches the noise level.

Record the RF signal level and the AF output level.

Increase the RF generator level by suitable increments and record the level of AF output at each point.

Continue until the RF input to the receiver reaches the maximum allowed by the receiver specification or until the AF output level no longer increases, whichever occurs at the lowest RF level.

FM receivers incorporate limiting circuits which reduce the level of the RF signal by clipping the extremities of the signal rather than by compression which is necessary with AGC circuits for AM receivers.

## Dx test (duplex testing)

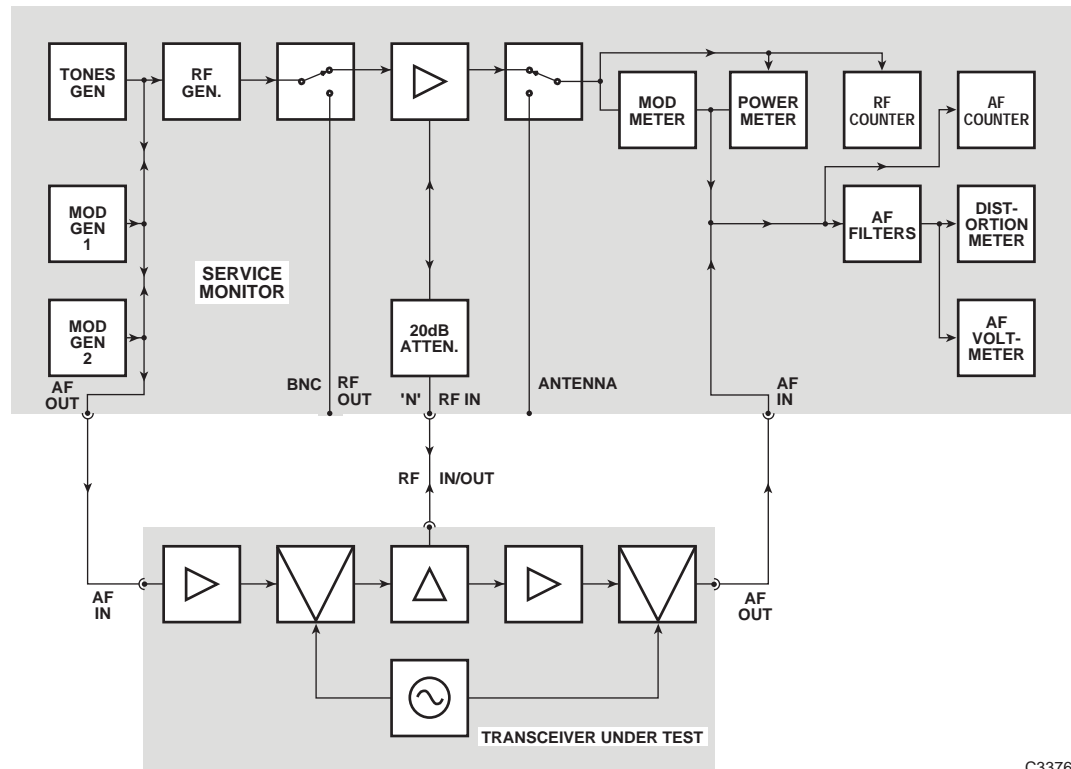

C3376

Fig. 3-11 One port duplex test setup

### Overview

With the Dx TEST mode selected, the screen and menu shown in fold out diagram (4-0) is displayed.

The Dx TEST mode is provided so that transmitter and receiver functions of transceiver operation can be studied simultaneously.

‘One port’ and ‘Two port’ transceivers can be tested. See Fig. 3-11, *One port duplex test setup*, and Fig. 3-12, *Alternative two port duplex setups*.

The Dx TEST mode display does not give all the information that is available from the individual Tx TEST mode and Rx TEST mode displays but these displays are available individually by selecting the appropriate test mode.

When interchanging between the Tx TEST mode, Rx TEST mode or Dx TEST mode, any active transmitter test and any active receiver test will remain functional.

There are two exceptions to this.

The first is with the modulation generators used for receiver tests and the audio generators used as a modulation source for transmitter tests. The two AF gen generators in the monitor serve both functions. Therefore, although both can be assigned to either function, if modulation is required on receiver and transmitter simultaneously, only single tones are possible.

The second exception is that the distortion measuring functions can be made only on the AF signal taken from the receiver under test and fed into the AF input connector of the monitor.

The output from the Tx TEST mode demodulator is fed to the AF amplifier as in Tx test mode. However, as the AF measuring circuits are continually switching functions when in Dx TEST mode, the output from the loudspeaker or headset is discontinuous.

# LOCAL OPERATION

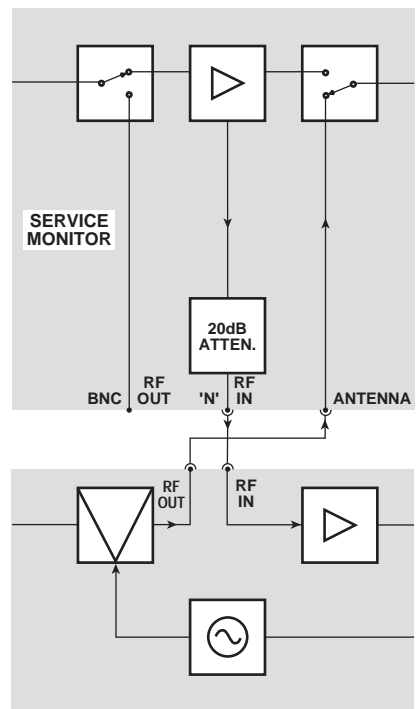
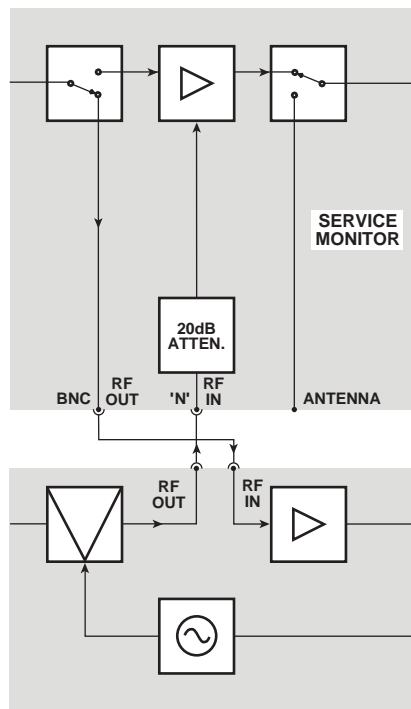
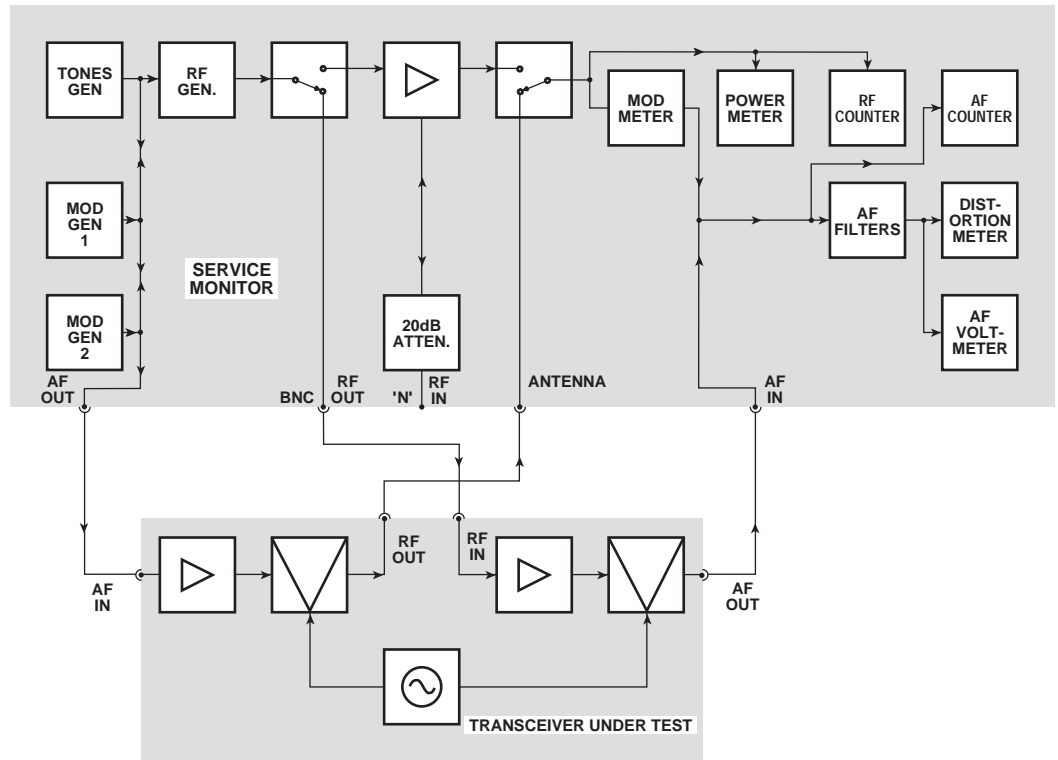

C3377

Fig. 3-12 Alternative two port duplex setups

## Spectrum analyzer

See Fig. 3-13, *Spectrum analyzer test setup*, and Fig. 3-14, *Spectrum analyzer test setup using the tracking generator*.

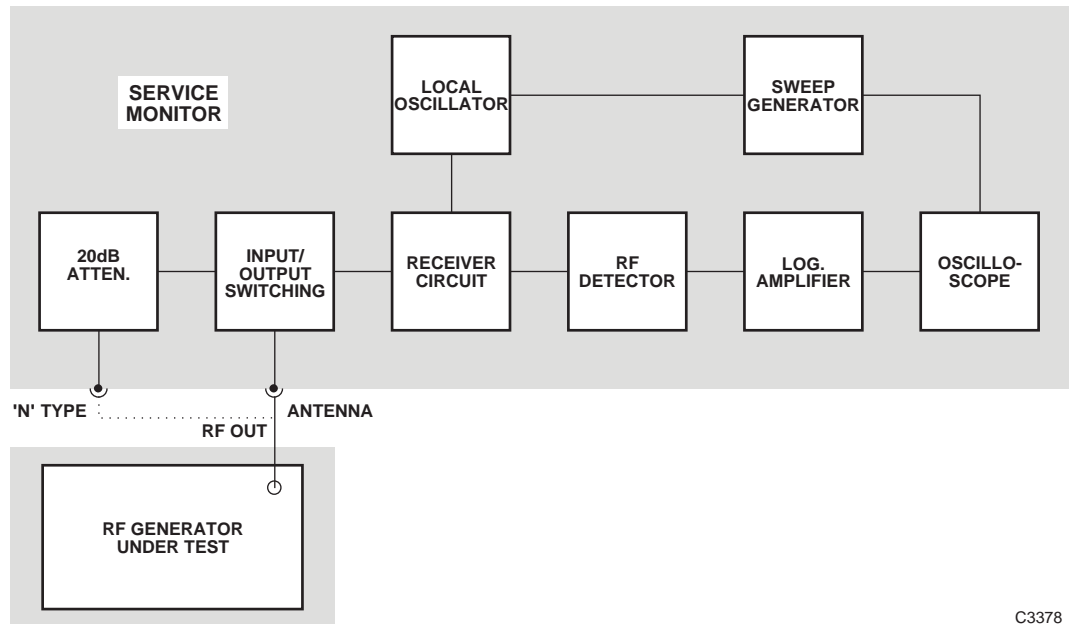

C3378

Fig. 3-13 *Spectrum analyzer test setup*

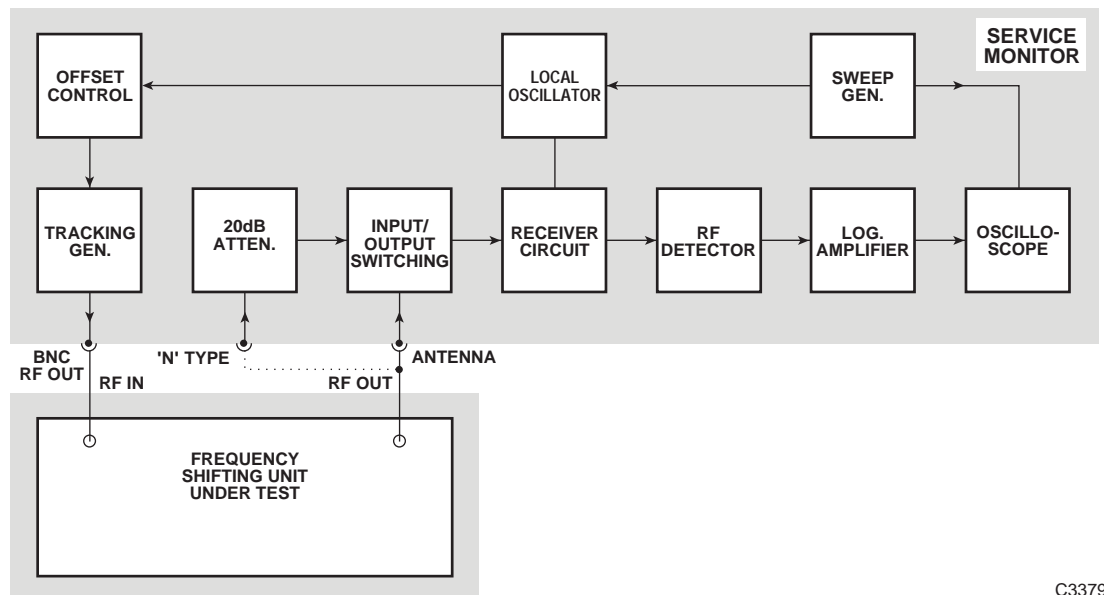

C3379

Fig. 3-14 *Spectrum analyzer test setup using the tracking generator*

## Overview

With the SPEC ANA mode selected, the screen and menu shown in fold out diagram (5-0) is displayed.

In the SPEC ANA mode, the sweep generator causes the acceptance frequency of the analyzer input circuits to repeatedly sweep over the selected frequency range.

The level of RF signal present at the active RF input connector is measured at regular points along the sweep and plotted progressively across the display, thus building up a graph of RF level against frequency.

The uses to which this facility can be put are varied. Within the radio communication field these can include examining the output of a transmitter for spurious radiations, for sideband response or noise levels.

The activity of nearby transmitters can be monitored as an aid to locating interference.

Using the tracking generator facility, the frequency response of filters can be checked and their pass bands plotted.

## Setting up

### Sweep range

The sweep range can be defined in two ways: either as a center frequency and a frequency span, or as a start frequency and a stop frequency.

The sweep range will depend on the signal or signals being examined and the harmonics and other spurious frequencies that are to be located.

The datum points are defined using the data input keys in the same manner as other frequency entries such as RF generator frequency or Tx frequency.

The datum point being defined is selected by pressing the relevant soft key, which will cause the datum to be highlighted under the spectrum analyzer graticule on the display. The corresponding datum will also be displayed. Thus START FREQ and STOP FREQ will appear together and SPAN and CENTRE FREQ will appear together.

### Center frequency

Pressing the [*Centre Freq*] key highlights the legend **Centre** under the graticule and allows the entry of any frequency within the spectrum analyzer RF range. This frequency will then be the center frequency on the graticule. If a figure is entered which would result in the lowest frequency of the span becoming a negative value, the span is reduced so as to set the span start to zero.

The variable control is active when the **Centre** legend is highlighted. It will not adjust the center frequency to a figure below half of the set span frequency range.

The FREQ [↑] and FREQ [↓] keys can be used to change the center frequency when the **Centre** legend is highlighted. Each press of one of these keys will increment the center frequency by the value last set up in the TxTEST mode.

### Span

Pressing the [*Span*] key highlights the legend **Span** under the graticule and allows the entry of any frequency within the spectrum analyzer RF range. This frequency will then be the frequency range covered by the frequency sweep. If the frequency entered conflicts with the center frequency, by requiring a bottom frequency below zero or an upper frequency that is outside the spectrum analyzer RF range, the span will be restricted.

The variable control is active when the **Span** legend is highlighted.

The FREQ [↑] and FREQ [↓] keys can be used to change the span setting when the **Span** legend is highlighted.

Each press of one of these keys will increase or decrease the span setting to the next point in the range 1 kHz, 2 kHz, 5 kHz,.....200 MHz, 500 MHz, 1.0 GHz. The span setting is restricted by the Center Frequency setting, as explained above.



### Start frequency

Pressing the *[Start Freq]* key allows the required start point to be entered using the data entry keys.

The variable control is active when the **Start** legend is highlighted.

**Note** that when using the variable control the span of the display remains constant. Therefore the stop frequency will follow any change to the start frequency. This is not the case when entering a start frequency by using the data keys.

### Stop frequency

The *[Stop Freq]* key highlights the **Stop** legend under the graticule and allows a frequency value to be entered from the data keys.

The variable control is active when the **Stop** legend is highlighted.

**Note** that when using the variable control, the span of the display remains constant. Therefore the start frequency will follow any change to the stop frequency. This is not the case when entering a stop frequency from the data keys.

### Peak find

Press the *[Peak Find]* key to set the marker to the highest level on the trace.

### Resolution bandwidth

The bandwidth of the spectrum analyzer acceptance circuits is selectable by the user.

The spectrum analyzer detector circuits will give an output corresponding to the mean level of signal within the acceptance passband. Therefore the choice of pass band, or resolution bandwidth, will depend upon the characteristics of the signal being examined.

The sweep speed is dependent on the resolution bandwidth. A high resolution analysis will take longer to process than a low resolution analysis.

The resolution bandwidth can be selected manually or set automatically.

To set the resolution bandwidth, first press the *[Res BW]* key. The menu shown in fold out diagram (5–12) will be displayed. The options then available are:

- Press the *[Auto Res BW]* key to set the resolution bandwidth to the optimum setting as determined by the Service Monitor software. The setting is then shown on the display. Use the return key as appropriate to resume setting up or testing.
- Press the *[Manual Res BW]* key to set the required resolution bandwidth by manual selection. The passbands available for selection are:

300 Hz	3 kHz	30 kHz	300 kHz	3 MHz
--------	-------	--------	---------	-------

The setting is then shown on the display. Use the return key as appropriate to resume setting up or testing.

- Press the *[Return]* key to exit the resolution bandwidth selection menu.

### Reference level

The top of the graticule represents the reference level that can be set between –50 dBm and +52 dBm

Pressing the *[REF LEVEL]* key will highlight the **Ref Level** legend and allow a level within the above range to be entered using the data entry keys. The entry must be terminated with the *[dBm]* terminator key.

### Vertical scale

The vertical scale can be displayed with a range of 10 dB/division or 2 dB/division. To select the vertical range, press the *[Vert Scale]* key, which will cause the menu shown in fold out diagram (5-2) to be displayed. Repeated presses of the *[10 dB/2 dB]* key will toggle the options, with the current choice being shown in the display.

The LEVEL [ $\uparrow$ ] and [ $\downarrow$ ] keys adjust the reference level in either 2 dB or 10 dB steps, depending on the setting of the reference level vertical range.

### Video filter

A video bandwidth filter can be switched into the display path to reduce the visible noise. To set the state of this, first press the *[Vert Scale]* key. Alternate presses of the *[Video Filter]* key will set the Video filter ON or OFF.

The filter frequency is selected automatically to provide optimum performance for the selected resolution bandwidth.

### Peak hold

The spectrum analyzer mode has a peak hold facility. When set ON, this facility displays the highest received signal level at each frequency point of the display. Signals of a lower level will not over-write the display, signals of a higher level will over-write previously recorded signals.

To set the state of the peak hold facility, first press the *[Vert Scale]* key. Alternate presses of the *[Peak Hold]* key will set the facility ON or OFF.

### Markers

#### Marker and $\delta$ Marker

The Marker and  $\delta$  Marker facility allows frequency and level measurements to be made to the signal displayed on the spectrum analyzer screen. The Marker or  $\delta$  Marker readout is shown at the lower left of the display. The RF level is given in dBm and the RF frequency in MHz, kHz or Hz.

Pressing the *[Mkr/ $\delta$ mkr]* key toggles through the following actions:

- Displays marker line and marker readout.
- Selects Marker function and allows adjustment using the variable control.
- Selects  $\delta$  Marker function and allows adjustment using the variable control.
- Removes marker line and marker readout from the display.

With Marker selected and the **Mkr** legend highlighted, adjusting the variable control will move the marker line across the display. The RF level and frequency of the signal at the intersection of the marker line and the displayed signal is shown by the marker readout.

With  $\delta$  Marker selected and the  **$\delta$ Mkr** legend highlighted, adjusting the variable control will move the marker line across the display. The marker readout shows *the difference* in RF level and frequency between the intersection of the *marker line* and the displayed signal *and* the intersection of the *display center line* and the displayed signal. A negative frequency value indicates that the marker line is at a frequency lower than the frequency of the display center line.

#### Marker to reference

Pressing the *[Marker to Ref]* key moves the marker line to the display center line.

- With the Marker function active, the marker readout will display the RF level and frequency of the signal at the intersection of the display center line and the displayed signal
- With the  $\delta$  Marker function active, the marker readout will display 0 dBm and 0 Hz until the marker line is repositioned.

### Tracking generator facility

The tracking generator facility uses the RF generator of the Service Monitor to provide a tracking signal source.

This allows the spectrum analyzer to show the frequency response of frequency dependent circuits such as filters.

The frequency response of any circuit connected between the tracking generator output and the spectrum analyzer input will be displayed.

**Note**

**When making calculations relating to frequency response results, take into account the impedance matching between the circuit and the Service Monitor. (See performance specification.)**

The frequency offset facility adds to the above capability by allowing tests to be made to frequency shifting circuits. The tracking generator's sweep may be positively or negatively offset with respect to the spectrum analyzer's output. The sum of the offset and the frequency analyzer span cannot produce a figure beyond the frequency range of the RF generator (see performance specification). Under these circumstances, the Service Monitor selects an appropriate span.

Because the RF generator is used as the tracking generator, control is required over both modes of its operation. The RF generator On/Off menu allows this to be enabled or disabled from the SPEC ANA mode.

### Setting the tracking generator

Control of the tracking generator parameters is carried out from the menu accessed by pressing the *[Track/RF Gen]* key. This key will either give direct access to the tracking generator parameters or to the RF generator On/Off menu, whichever was used last. If the RF generator On/Off menu is reached, pressing the *[Track Gen]* key will display the tracking generator parameter control menu shown in fold out diagram (5-5). This menu gives the following options:

**Tracking generator ON or OFF.**

Alternate presses of the *[T/Gen On/Off]* key will toggle the tracking generator output ON and OFF. When in the ON condition, the RF level and frequency offset will be shown on the display.

**Tracking generator level.**

Pressing the *[Level]* key will highlight the **Track Gen Level** legend and allow the level to be altered, either by the variable control or by entering a new value using the data entry keys.

**Locking tracking generator frequency to sweep frequency.**

Pressing the *[Freq Locked]* key will lock the Frequency of the tracking generator to the sweep oscillator of the spectrum analyzer. When locked, the legend Locked is shown under the Offset legend on the display. Repeated presses of this key will toggle between Locked, (zero offset), and the offset previously set (see below).

**Setting the value of the tracking generator frequency offset.**

A new value is entered by first pressing the *[Freq Offset]* key and then using the data entry keys.

Additionally, the RF generator may be disabled from the spectrum analyzer tracking generator menu. Pressing the *[RF Gen]* key will display the RF Generator On/Off menu. Repeated presses of the *[RF Gen On/Off]* key will display the RF Gen Off or the RF Gen On legend. This indicates the state of the RF generator when the tracking generator facility is off.

Look and Listen

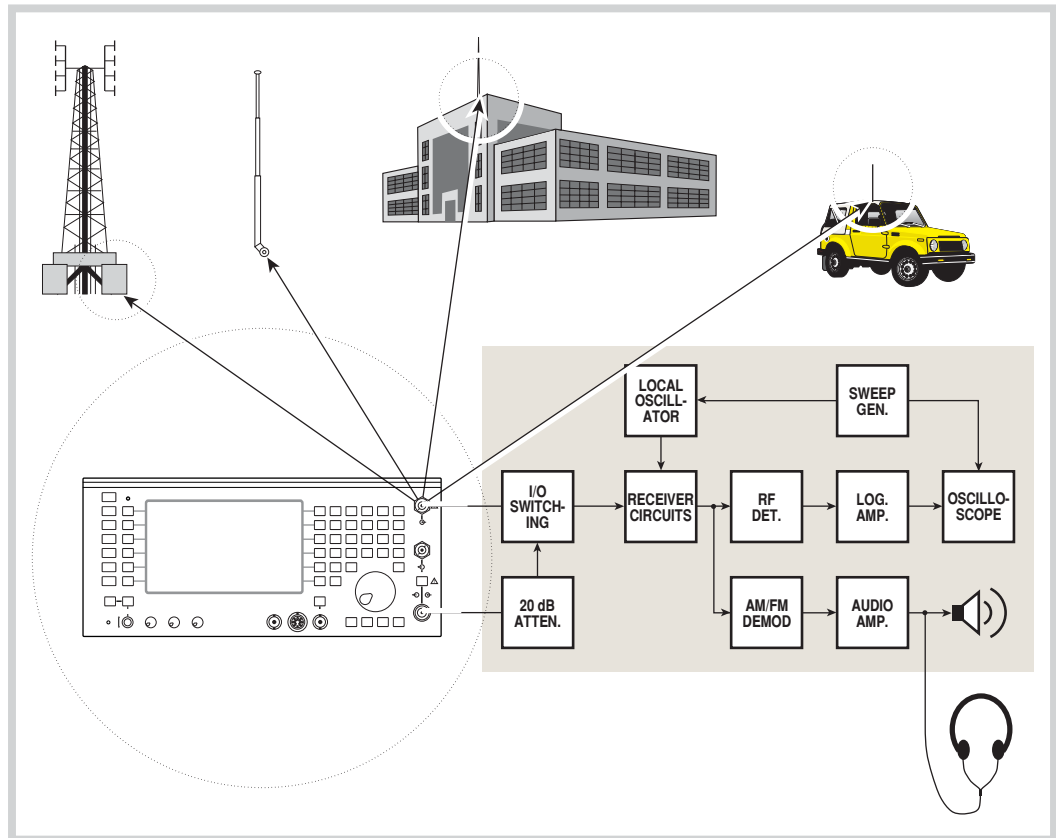

C6055

Fig. 3-15 Spectrum Analyzer setup, Look and Listen function

The optional Look and Listen facility allows the instrument to be used for 'OFF-AIR' monitoring of transmissions while examining the area of radio spectrum on which the transmission being monitored is centered. The width of RF spectrum scanned in the Look and Listen mode is adjustable in steps from a minimum of 100 kHz to 1 MHz.

The RF signal from a suitable antenna is coupled to the Service Monitor through either the antenna BNC connector or the 'N type' connector on the front panel. The signal is passed through the spectrum analyzer circuits to be displayed as a conventional spectrum analyzer display. The listen demodulator obtains its signal from a non-sweeping IF circuit and is tuned to the center frequency of the display. The output from it is routed through an AF amplifier to the internal loudspeaker, to the accessory socket and to the 'demod out' socket. See Fig. 3-15, *Spectrum Analyzer setup, Look and Listen function.*

### Setting up

Pressing the *[Look & Listen]* key from the SPECTRUM ANALYZER menu selects this option. The menu shown in fold out diagram (5-6) is displayed.

### Center Freq and Span setting

When operating in the 'Look & Listen' mode, the spectrum display is defined only by the Centre Freq and Span settings.

The center frequency is set by selecting the *[Centre Freq]* key to highlight the legend **Centre** at the bottom of the display and then entering a value using the data input keys. Fine adjustment can be made using the variable control when the **Centre** legend is displayed as above.

With an input signal displayed, adjusting the center frequency will allow the listen detector to be tuned to an observed signal.

The Span setting controls the sweep range covered by the spectrum analyzer. When in the Look and Listen mode the sweep span is selected from the Span menu accessible by pressing the *[Span]* key. Four span widths are available as listed below.

1 MHz	500 kHz	200 kHz	100 kHz
-------	---------	---------	---------

### Demod settings

The 'listen' demodulator and its associated circuits are set to extract the information from the signal tuned to the center frequency of the display. The following options are available through the *[Demod]* key.

<b>Modulation type</b>	AM	FM
<b>De-emphasis</b>	ON	OFF
<b>AF filter</b>	300 Hz to 3.4 kHz	15 kHz LP

Instruments can be set to 15 kHz or 300 kHz. This also is irrespective of the spectrum analyzer resolution bandwidth selected. The current setting is shown to the left of the display. To change the setting, first press the *[Listen IF BW]* key, which will display *[15 kHz]* and *[300 kHz]* keys. Press the appropriate key to select the required setting.

Switching to the Tx TEST mode after a signal has been located will allow the signal to be monitored with the IF bandwidth set to 300 Hz, 3.0 kHz, 30 kHz or 300 kHz.

**Resolution bandwidth selection**

The resolution bandwidth for the display can be selected from the following through the [Res BW] key:

Auto Res BW	3 kHz	30 kHz	300 kHz
----------------	-------	--------	---------

With automatic resolution bandwidth selected, the resolution bandwidth is dependent on the sweep span, as shown below:

Span Setting	Resolution Bandwidth
1 MHz	30 kHz
500 kHz	30 kHz
200 kHz	3 kHz.
100 kHz	3 kHz.

When operating in the Look and Listen mode, some functions or options of SPEC ANA mode will be available to the user. Reference to these is made on the display but their condition cannot be changed without returning to the main spectrum analyzer display. These are:

<b>Reference level dB/div</b>	2 dB	10 dB
<b>Video filter option</b>	OFF	ON
<b>Peak hold option</b>	OFF	ON

**Input sensitivity**

The input sensitivity of the Service Monitor in the Look and Listen mode is the same as for the normal spectrum analyzer input. The reference level can be set using the data input keys, or adjusted using the variable control. The LEVEL [↑] and [↓] keys adjust the reference level in either 2 dB or 10 dB steps depending on the setting of the reference level vertical range.

**Making measurements**

The monitor can be used to determine the frequency of a transmission and to identify the modulation type and content of asymmetric transmissions. When the transmission to be examined is visible on the display, adjust the center frequency line on the display to coincide with the peak of the signal. This will be the carrier frequency and will be shown as a digital readout. Progressively reduce the span and optimize the filtering and demodulation method while listening to the demodulated output. As the span is reduced the center frequency may need optimizing.

The peak level of the signal can be determined by reference to the RF level scale on the display.

The top of the graticule represents the reference set on the display. Each division of the graticule represents either 10 dB or 2 dB, as set in the vertical scale setup menu of the main SPEC ANA mode.

## AF test (audio frequency testing)

### Overview

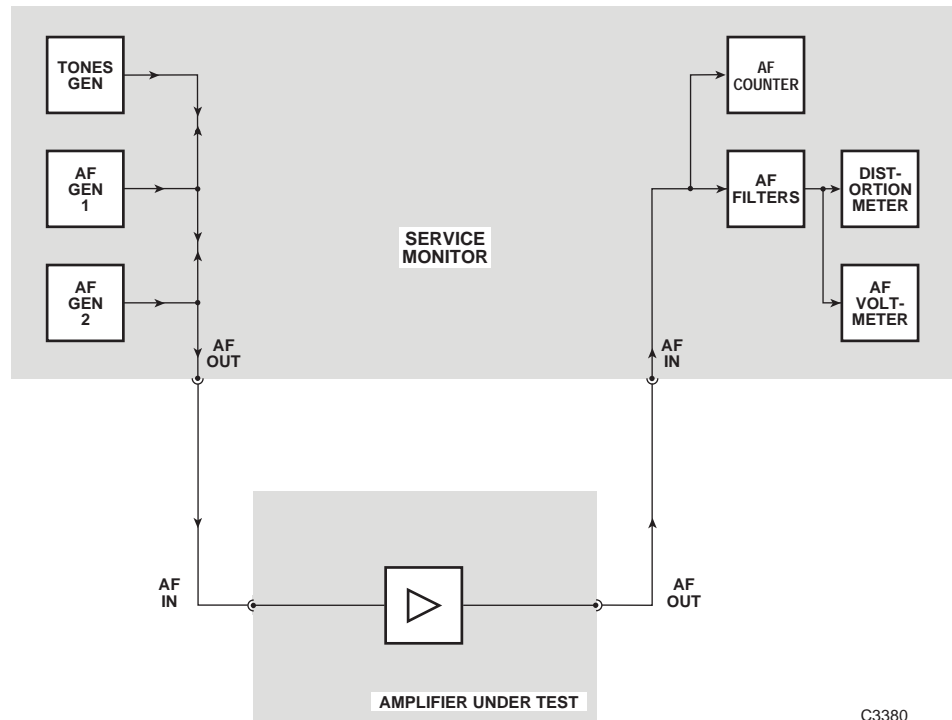

C3380

Fig. 3-16 Audio test setup

To enter the AF TEST mode press the blue [AF TEST] key. This will cause the screen and menu shown in fold out diagram (6-0) to be displayed.

When the AF TEST mode is selected, the combined output from the AF generators, plus the data generator facility, is available at the AF output connector. Signals fed to the AF input connector are routed to the AF signal analyzing circuits. See Fig. 3-16, *Audio test setup*.

The frequency, level and shape parameters of the audio generators can be set within the following limits:

<b>Freq. range</b>	5 Hz to 33 kHz
<b>Level range</b>	0.1 mV to 4 V rms
<b>Shape option</b>	Sine or square

By using the AF signal generators and the measuring functions of the Service Monitor, it can be used for performance testing of passive and active AF circuits such as filters and amplifiers.

Frequency, level, distortion level, SINAD level and signal to noise ratio measurements can be made. The oscilloscope facility is available to observe and measure waveforms. The tones receiver facility is available for the performance checking of features such as digitally coded squelch generators.

The AF output signal and the measuring facilities can each be used independently.

## Setting up

The audio generators are the signal sources for AF testing. Good practice is to disable the source until tests are set up. This is achieved by selecting each of the generators in turn and pressing the orange [ON/OFF] function key to display Off adjacent to each of the generator's output data on the display. The required generator or generators can be set up in the Off condition and enabled by the above procedure when all connections and setting are complete.

To select and set up the audio generators press the [Audio Gen] key. This will display the audio setup menu shown in fold out diagram (6-2).

Repeated presses of the [Gen1/Gen2] key will highlight the AF1 and AF2 legends in turn to indicate the selected generator.

Set up the audio generator(s) for the required frequency and output level by using the soft keys and data input keys:

[Gen 1/Gen 2] to select AF1, then, [FREQ][n]...[n][kHz/Hz]  
 [LEVEL][n]...[n][V/mV/dBm]  
 then [Gen 1/Gen 2] to select GEN2 if required,...[.../dBm]

The FREQ [↑] and [↓] and the LEVEL [↑] and [↓] keys can be assigned to AF generator frequency and level. See [Incremental adjustments](#), which starts on page 3-67.

The shape of each audio generator output waveform can be either sine or square wave. This is controlled by first selecting the audio generator as for On/Off control above, then pressing the [SHAPE] key to toggle between the options.

## Input level measurement

The measured level of signals applied to the AF INPUT connector can be displayed in volts, dBm, dBV or mW. The selection is made from the AF Setup page, as described under *Audio Level Measured in:* on page 3-17. When the input level is displayed in dBm or mW, the signal is assumed to be measured across the impedance selected on the Audio Input Impedance Match selection made from the AF Setup page. (See [Audio Input Impedance Match](#) on page 3-17.)

The 600 Ω interface unit allows the Service Monitor to provide a 600 Ω termination. (See [Audio Input Impedance](#) on page 3-17.) With the input impedance set at 600 Ω, the indicated level is that of the input to the Service Monitor. With the input impedance set at High, the indicated level is that of the input to the Service Monitor with an assumed 600 Ω load.

## Input filtering

The AF signal to the AF INPUT connector on the front panel can be filtered using high pass, low pass or band pass audio filters and with weighting filters as required.

Press the [AF Filter] key. The right hand soft keys change, to allow selection of AF filters as shown below. Press the [Return] key after selecting the required filter.

High Pass	Low Pass	Band Pass	CCITT <sup>†</sup> or C-MESS <sup>‡</sup>
-----------	----------	-----------	--

<sup>†</sup> Only if option 23 (CCITT filter) is fitted.

<sup>‡</sup> Only if option 24 (C-MESS filter) is fitted.

The high pass filter options are 50 Hz or 300 Hz.

There are five low pass filter soft keys. The 50 kHz LP filter can be considered to be the 'unfiltered' selection as this represents the normal full bandwidth of the audio circuits.

The other four low pass preset filters can each be set to any cut-off frequency within the range 250 Hz to 1.0 kHz and 3.0 kHz to 20.0 kHz.

The band pass preset filters can be customized by selecting either of the high pass options in combination with any of the four preset low pass filters.

The preset filters are set from the HELP/SETUP facility. The AF Filter setup [explanation](#) starts on page 3-11.



## Distortion measurement

The distortion measuring facilities of the monitor are available within the AF TEST mode. Pressing the *[Audio Meter]* key, to change the soft keys as shown in fold out diagram (6-3), then pressing the *[Dist/S-N]* soft key, accesses the distortion measurement menu shown in fold out diagram (6-3-2).

Pressing each of the soft keys will have the following effect:

### Off

Disables any active distortion measuring function.

*Hint. By disabling this function, the time taken to measure the remainder of the measurement functions is shortened thereby reducing the update time.*

### S/N

Selects signal to noise ratio as the measurement method. The AF generator is disabled and enabled alternately by the monitor software and the total output level from the circuit under test is measured by the AF voltmeter at each state. See Fig. 3-7 a, & d *Distortion level and signal to noise level measurements*, on page 3-36.

Calculations are performed by the software to calculate the signal to noise ratio using the formula:

$$\begin{aligned} \text{S/N} &= 20 \log \frac{V_1}{V_2} \text{ dB} \\ &= 20 \log \frac{(S + N + D)}{N} \text{ dB} \end{aligned}$$

The distortion bar chart ranges available are 0 to 30 dB and 0 to 100 dB. The signal to noise ratio is displayed as a digital read-out above the bar chart. The AF test menu is recalled automatically after pressing this key.

### SINAD

Selects SINAD as the measurement method. The AF generator is set to 1 kHz and the 1 kHz distortion notch filter is switched alternatively in and out of circuit, with the signal level being measured by the AF voltmeter in each state. See Fig. 3-7 a, b, & c, *Distortion level and signal to noise level measurements*, on page 3-36.

The monitor software calculates the SINAD level according to the formula:

$$\begin{aligned} \text{SINAD} &= 20 \log \frac{V_1}{V_2} \text{ dB} \\ &= 20 \log \frac{(S + N + D)}{(N + D)} \text{ dB} \end{aligned}$$

The distortion bar chart ranges available are 0 to 18 dB and 0 to 50 dB. The SINAD level is displayed as a digital readout above the bar chart. The AF test menu is recalled automatically after pressing this key.

### Dist'n

Selects distortion percentage as the measurement method. The AF generator is set to 1 kHz and the 1 kHz distortion notch filter is switched alternatively in and out of circuit, with the signal level being measured by the AF voltmeter in each state. See Fig. 3-7 a, b, & c, *Distortion level and signal to noise level measurements*, on page 3-36.

The monitor software calculates the distortion level according to the formula:

$$\begin{aligned}\text{Distortion} &= 100 \frac{V_2}{V_1} \% \\ &= 100 \frac{(N+D)}{(S+N+D)} \%\end{aligned}$$

The distortion bar chart ranges available are 0 to 10% and 0 to 30%. The distortion percentage level is displayed as a digital readout above the bar chart. The AF test menu is recalled automatically after pressing this key.

### \*Oscilloscope\*

The oscilloscope facility can be used from within the AF test mode to examine the signal present at the AF input socket. The sensitivity of the Y axis is adjustable from 10 mV/division to 20 V/division in a 1,2,5 sequence.

The input to the oscilloscope is taken directly from the AF input, and not through any of the AF filters. Therefore measurements obtained on the AF voltmeter will show the effects of filtering, whereas those made using the oscilloscope will not.

A section on the use of the [oscilloscope facility](#) starts on page 3-88.

## Incremental adjustment keys

### General

This section provides information on the use of the incremental adjustment keys. Other sections of this chapter have specific references to these keys; this section gives general information.

The incremental adjustment keys are located under the variable control, with one pair designated **FREQ**, [↑] and [↓], the other pair designated **LEVEL**, [↑] and [↓]. Each pair can be assigned to a selected parameter within a test mode, which then allows that parameter to be adjusted in steps.

**Note** that the **FREQ** [↑] and [↓] keys, and the **LEVEL** [↑] and [↓] keys, do not have to be assigned to the same generator.

The parameters that can be selected are:

Parameter	Test mode
Tx frequency	Tx test mode
AF generator 1 frequency	Tx test mode
AF generator 2 frequency	Tx test mode
AF generator 1 level	Tx test mode
AF generator 2 level	Tx test mode
RF generator frequency †	Rx test mode
RF generator level	Rx test mode
Modulation generator 1 frequency	Rx test mode
Modulation generator 2 frequency	Rx test mode
Modulation generator 1 level	Rx test mode
Modulation generator 2 level	Rx test mode
AF generator 1 frequency	AF test mode
AF generator 2 frequency	AF test mode
AF generator 1 level	AF test mode
AF generator 2 level	AF test mode
RF center frequency	Spec ana.
RF frequency span ‡	Spec ana.
RF level ‡ ‡	Spec ana.

† The RF generator can be made to step up or down through each channel of a mobile radio system type, by setting the  $\Delta$  frequency to the channel spacing frequency.

‡ The SPEC ANA mode SPAN adjustment using the **FREQ** [↑] and [↓] keys, sets the span to predetermined values. These are not adjustable by the user. See Setting up; SPAN on page 3-56.

‡ ‡ The SPEC ANA mode RF LEVEL adjustment using the **LEVEL** [↑] and [↓] keys, changes the RF reference level in steps of 1 display division. This can be either 2 dB/div or 10 dB/div, dependent on the value of dB/div set in the SPEC ANA mode.

## Assigning

The assignment of the incremental keys is shown in the display, along with the step value.

To assign a parameter to a pair of keys, first select the parameter as if to change the value using the data input keys, but rather than entering a new value press the orange [ALT Δ] key. Now enter the value of the step to be incremented at each key press, followed by the correct terminator key.

For example to assign the FREQ [↑] and [↓] keys to AF generator 1 in the Tx TEST mode and to step up or down by 500 Hz steps, follow this procedure:

From the Tx TEST display press the [Audio Gen] key.

Use the [Gen 1/Gen 2] key to select **AF1**

Press the orange [LEVEL] key.

The **LEVEL** legend following **AF1** will be highlighted.

Press the orange [Δ INC] key, followed by [5] [0] [0] and the [Hz] terminator key.

The display will show the legend

Increments  
AF1 FREQ: 500 Hz

Now each press of a FREQ [↑] or [↓] key will increase or decrease the output frequency of AF generator 1 by 500 Hz.

Points to note are:

Each press of a FREQ [↑] or [↓] key will be effective from the current point. Thus if the frequency of the generator in the above example has been incremented to **1,500 Hz** and *then adjusted* by use of the variable control (or the data entry keys) to **1,495 Hz**, the next incremental step down will produce a frequency of **995 Hz**.

The assignment and value of a incremental setting will be retained, with the mode setup, when a different mode is selected or the instrument is powered down. This is of particular note when assigned to the AF generators as they are also the modulation generators within the Rx TEST mode and the AF generators within the AF TEST mode.

The incremental keys cannot be used when in the Dx TEST mode.

## Use within spectrum analyzer mode

The SPEC ANA mode makes use of the FREQ [↑] and [↓] keys for span adjustment. The span is ranged up or down in a 1, 2, 5 sequence, from 1.0 kHz to 1.0 GHz.

Adjustment to the span by these keys is linear about the center frequency and will not adjust below zero or above the top frequency limit.

When the **Centre** legend is highlighted the FREQ [↑] and FREQ [↓] keys will increment the center frequency by the value last set up in the TxTEST mode.

The LEVEL [↑] and [↓] keys adjust the reference level of the spectrum analyzer in either 2 dB or 10 dB steps depending on the setting of the reference level vertical range.

## Tones

### Tones sub-mode

Audio tones and digital code signals are used for many purposes within radio communication systems. The Service Monitor has a TONES mode accessed from the Tx TEST, Rx TEST, Dx TEST and AF TEST modes.

This gives facilities for testing tone calling and control systems of the following types.

- Sequential Tones. A selective calling system using audio tones.
- CTCSS (Continuous Tone Coded Squelch System).
- DCS (Digitally Coded Squelch).
- DTMF (Dual Tone, Multi-Frequency).
- POCSAG (Post Office Code Standardization Advisory Group). A paging system using digital signaling.

The tone mode is entered from the top level screen of any main mode, other than SPEC ANA.

Pressing the *[Tones]* key will display the screen shown in Fig. 3-17, *Tones selection screen and Tones mode receiver input level setting*.

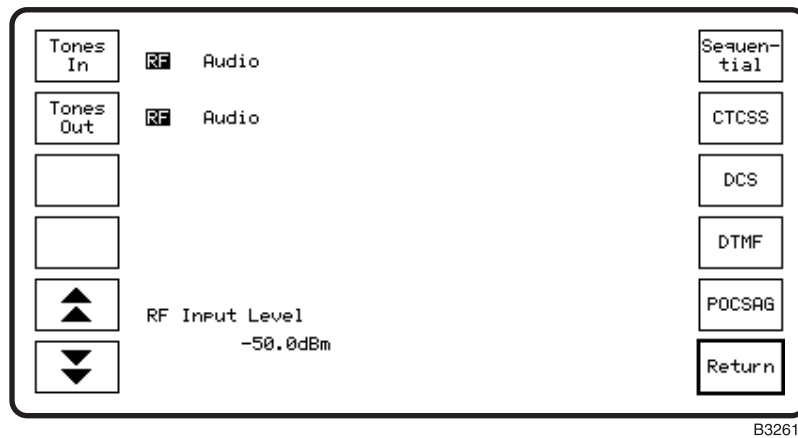

Fig. 3-17 Tones selection screen and Tones mode receiver input level setting

### Observing tones signals in other test modes

The effect of any tones signaling on transmitters or receivers under test can be studied using any test mode of the Service Monitor.

When a test mode is selected, (either by pressing the [Tx TEST] key, [Rx TEST] key etc. or by pressing the *[Return]* key), while any tones signal is running continuously (CTCSS or DCS Tones On; Sequential or DTMF continuous mode Sending), the tones will continue to be generated. See the Tones ON/OFF control section of each specific tones description.

## Signal routing

The tones sub-mode can be entered from either Tx TEST, Rx TEST, Dx TEST or AF TEST modes.

The encoded signal produced by the Service Monitor can be routed to the equipment under test in two ways:

- As a modulated RF signal from either of the RF output connectors.
- As an AF signal from the AF GEN OUT connector.

Similarly, an encoded signal produced by the equipment under test can be routed to the Service Monitor in two ways:

- As a modulated RF signal to either of the RF input connectors.
- As an AF signal to the AF INPUT connector.

The input and output routing settings are made from the TONES selection screen. Pressing the *[Tones In]* or *[Tones Out]* key alternates the setting between **RF** and **Audio**. The selected settings will be retained until reset, either manually or by recalling instrument settings. Any tone sequence or continuous tone that is running when an input or output routing setting is changed will be stopped.

## RF input attenuators

The RF input circuits of the Service Monitor are auto-ranging under most operating conditions. When operating in some of the tones modes this can be a disadvantage as the tones decoders need to receive the leading burst of any transmission. Therefore when TONES mode is selected, the auto-ranging function is disabled and the RF input sensitivity of the service monitor is set manually.

This is done by using the *[▲]* and *[▼]* keys on the TONES selection screen. For correct operation of the TONES decoders, the input signal level should *not exceed* the level set.

Each key press will switch the sensitivity of the service monitor up or down by 10 dBm. If the level of the applied signal is unknown, it can be measured using the Tx TEST mode. The Service Monitor RF Input Level can then be set *above* the measured level.

The following table shows the RF input level settings that are available for either of the RF input connectors.

RF N in		RF Antenna in		Audio
398 W	56.0 dBm	1.00 W	30.0 dBm	<40.0 V
39.8 W	46.0 dBm	100.0 mW	20.0 dBm	<20.0 V
3.98 W	36.0 dBm	10.0 mW	10.0 dBm	<10.0 V
398 mW	26.0 dBm	1.00 mW	00.0 dBm	<4.0 V
39.8 mW	16.0 dBm	100 μW	-10.0 dBm	<2.0 V
3.98 mW	6.0 dBm	10 μW	-20.0 dBm	<1.0 V
398 μW	-4.0 dBm	1 μW	-30.0 dBm	<400 mV
40 μW	-14.0 dBm		-40.0 dBm	<200 mV
4 μW	-24.0 dBm		-50.0 dBm	<100 mV

When using the AF INPUT connector for TONES operation, the *[▲]* and *[▼]* keys on the TONES selection screen set the AF input sensitivity. The column headed Audio, in the above table, lists the AF input settings. The AF input signal level should be less than that shown for the current setting.

## Sequential tones

### Overview

Sequential tones signaling systems use sequences of audio tones to control various functions of a radio system. There are many systems in operation world-wide, all using up to 15 tones labeled with the hexadecimal digits 0 to E with 'No Tone' as F. Some systems make use of extended tones for certain functions.

Each version has its own tone allocation tables for the 15 tones and its own timing for tone duration.

The versions for which tone allocation tables and tone duration values are included in the Service Monitor are:

CCIR	ZVEI	DZVEI	EEA	EIA	USER 1	USER 2
------	------	-------	-----	-----	--------	--------

The USER 1 and USER 2 tables allow tone frequencies and tone durations to be programmed by the user.

This Service Monitor has encoding facilities with variable parameters, which allow signals to be produced for testing systems using precise values and adverse values. The decoding facility will measure the frequency and duration of the received tones, match the results against the appropriate look-up table and list the results with the identification of each tone.

Observe notes relating to signal routing and RF input attenuators at beginning of this section. See page 3-70.

Continuous sequential tones can be produced at the same time as CTCSS or DCS tones.

### Using the decoder

The sequential tones decoder will function when the instrument is in the Rx TEST mode.

Press the *[Decoder]* key and the AF SEQUENTIAL DECODER screen will be displayed. A tone sequence fed into the AF input will be decoded and the results will be displayed.

## Testing sequential tone receivers

### Using the encoder

To test the operation of receivers using sequential tone signaling, proceed as follows:

#### Rx TEST settings

Select the receiver test mode by pressing the [Rx TEST] key.

Set the RF output frequency of the Service Monitor to that set on the receiver.

Ensure that the RF generator within the Service Monitor is in the OFF condition. This should remain OFF until the Service Monitor and the receiver under test are set up and properly interconnected.

Make a suitable RF connection between one of the Service Monitor RF output connectors and the RF input connector of the receiver.

Set the RF output level from the Service Monitor to an appropriate setting.

Select the 'RF SEQUENTIAL TONES' function by using the key sequence, *[Tones]*, *[Sequential]*. The screen and menu shown in Fig. 3-18, *RF Sequential tones encoder display, main menu*, will be displayed.

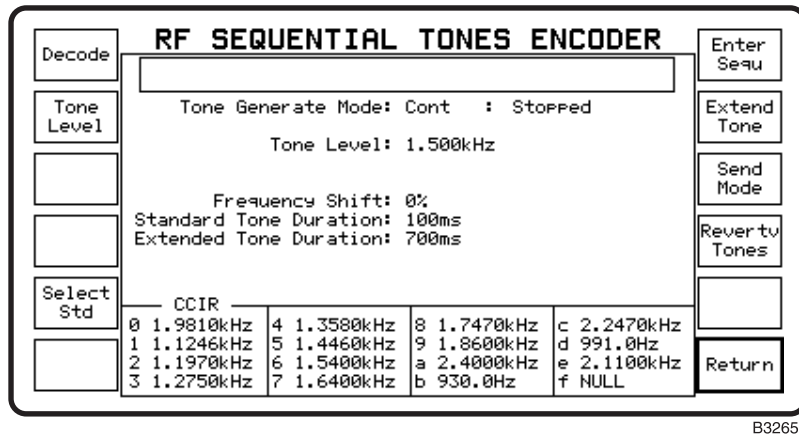

Fig. 3-18 RF Sequential tones encoder display, main menu

### Setting the Tones mode

The display is divided into three areas.

- At the bottom of the display is a table listing the frequencies allocated to the 15 tones, 0 to E. Above the table is shown the system type, i.e. CCIR, ZVEI etc.
- At the top of the display is a panel in which the tone sequence to be transmitted is assembled or edited.
- The center of the display shows information relating to the parameters of the system.

Check that the system type shown above the frequency table is the same as the system type on which the receiver to be tested operates. If this is not correct press the [Select Std] key to display the SELECT TONES STANDARD screen and menu as shown in Fig. 3-19, Sequential tones standard selection menu.

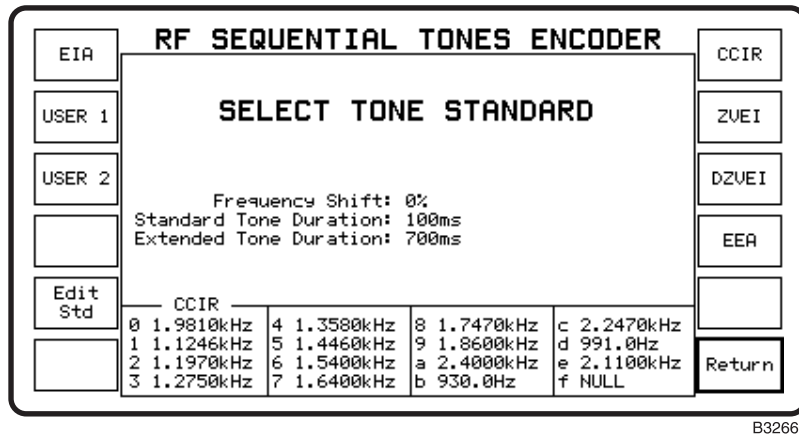

Fig. 3-19 RF Sequential tones standard selection menu

Select the correct system standard by pressing the appropriate key. The frequency allocation table will change to relate to the selected standard and the settings of the tone duration parameters will also change to the correct values for the system.

Return to the main sequential tones menu.

When the frequency allocation table is correct for the system, check that the other parameters are correctly set. The tone modulation level has a default setting of 1.5 kHz but can be set by the user to any level up to the instrument's maximum of 75 kHz.



### Creating the tone sequence

To create the required tone sequence, first press the *[Enter Sequ]* key to display the cursor in the tone sequence panel.

Enter the required sequence by using any of the data entry keys 1 to 9, zero and the Hex digits A to E. The *[Extend Tone]* key is used to convert a standard tone to an extended tone or an extended tone to a standard tone. With the cursor positioned over the tone to be changed, each press of the *[Extend Tone]* key will extend it or reduce it to standard. The cursor is moved by using the variable control.

### Editing a tone sequence

An existing tone sequence can be edited as required. Using the rotary control, move the cursor over the character to be changed. To delete the unwanted character and insert a new character in its place, press the data key corresponding to the new character. To delete an unwanted character and close up the sequence, press the [DELETE] key.

### Editing the tone standard

#### Tone frequency shifting

The frequency of all the tones in the table can be collectively altered by up to  $\pm 10\%$  for tolerance checking.

#### Tone duration

The duration times for standard and extended tones are set to the system standard when the system is selected. They can be altered by the user from the EDIT TONE STANDARD screen, which is accessed by pressing the *[Edit Std]* key on the SELECT TONE STANDARD screen.

Press the *[Tone Durat'n]* key or the *[Tone Ext Dur]* key as appropriate and enter the required duration using the data entry keys and the [ms] terminator key.

### Producing the sequential tone signal

The Service Monitor has four tone modes for producing sequential tone signals. These are selected after pressing the *[Send Mode]* key. This will display the soft keys shown below:

*[Cont Tones]* Generates the tone sequence repeatedly.

*[Tone Burst]* Generates one sequence of the tones then stops.

*[Step Tones]* Each initiation causes one tone of the sequence to be generated for the stated duration. Subsequent initiations step to the next tone in the sequence.

*[Single Tone]* Pressing any data entry key will cause the corresponding tone to be generated for the stated duration.

*[Return]* Returns to the main Sequential Tones menu.

The selected send mode, i.e. Cont, Burst, Step or Single, will be shown on the display against the legend Tone Generate Mode.

Before sending tones using the RF generator ensure that the RF generator is ON.

### Tone ON/OFF control

When the RF SEQUENTIAL ENCODER screen or the AF SEQUENTIAL ENCODER screen is displayed, the sequential tones are turned on or off by the orange [ON/OFF] function key.

If the sequential tones are ON and the Tx TEST, Rx TEST, Dx TEST or AF TEST mode selected, the tones will continue to be generated.

If the tones out routing has been set to give RF tones, this is provided by modulation generator 1. The legend ---Tones --- will be displayed against MOD1 FREQ on the RECEIVER TEST or DUPLEX screens. If **MOD1** is selected, the sequential tones can be controlled by repeated presses of the orange [ON/OFF] function key. If **MOD1 FREQ** is selected, the tones are still controlled by the orange [ON/OFF] function key, but if a frequency is entered using the data keys or if the variable control is adjusted, the tones will cease. They can then be re-started *only* when the RF SEQUENTIAL ENCODER screen or the AF SEQUENTIAL ENCODER screen is displayed.

If the tones out routing has been set to give AF tones, this is provided by audio generator 1. The legend --Tones-- will be displayed against AF1 FREQ on the TRANSMITTER TEST, DUPLEX or AF TEST screens. If **AF1** is selected, the tones can be controlled by repeated presses of the orange [ON/OFF] function key. If **AF1 FREQ** is selected, the tones are still controlled by the [ON/OFF] key, but if a frequency is entered using the data keys or if the variable control is adjusted, the tones will cease. It can then be re-started *only* when the RF SEQUENTIAL ENCODER screen or the AF SEQUENTIAL ENCODER screen is displayed.

### Testing sequential tone transmitters

To test the operation of transmitters sending sequential tones calling signals, proceed as follows:

Select the Tx TEST mode, then make all the required settings and RF connections for conventional transmitter testing. Refer to the Tx TEST section of this manual for the correct procedures. Set the frequency of the Service Monitor input to that of the transmitter output.

Key the transmitter and check that the Service Monitor is obtaining a signal from the transmitter.

Select TONES mode. The attenuators in the receive path of the Service Monitor will be held at their current setting. Press the *[Sequential]* key. The RF SEQUENTIAL TONES DECODER screen and menu is displayed. See Fig. 3-20, *Sequential tones decoder screen*. If the encoder screen is displayed, press the *[Decode]* key.

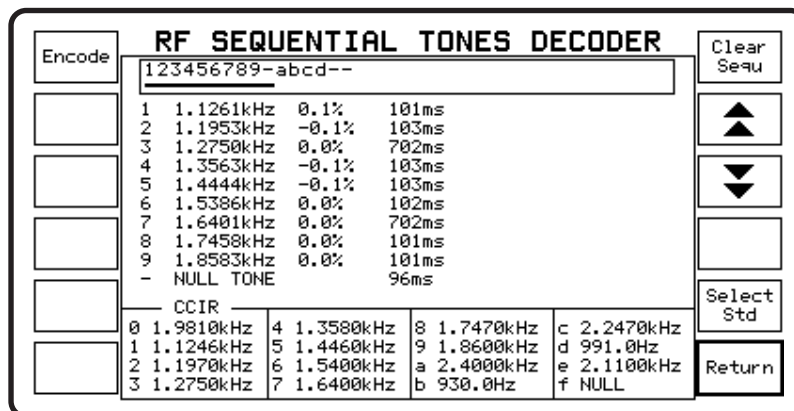

B3268

Fig. 3-20 RF Sequential tones decoder screen

Check that the tones standard shown above the tone number/frequency list corresponds to the system used by the transmitter. If this is not correct, select the correct standard from the menu accessed through the *[New Std]* key.

Key the transmitter to transmit a tone sequence. Within the Service Monitor the TONES decoder will decode the tones sequence obtained from the modulation meter.

The decoded sequence will appear in the panel at the top of the display, with the first 10 characters underlined. The sequence decoder store can hold up to 40 decoded characters. Any received in excess of this will be lost.

The underlined tones are listed in the center of the display with an analysis of the parameters of each tone as below:

- The measured frequency of each tone.
- The percentage error from the true tone frequency.
- The duration of each tone.

By using the [▲] or [▼] keys, the analysis of all tones in the decoded sequence can be shown.

The stored sequence can be cleared from the store by pressing the [*Clear Sequ*] key.

### Revertive tones

Revertive tones signaling takes various forms. The common factor is that a tone sequence received by a mobile transceiver or other receiver, will trigger a second sequence to be returned.

The second sequence may be a duplicate of the first or a different sequence. It can be used to modulate a signal on a reverse channel or on a different channel. For some applications either or both of the tone sequences may be used as an AF signal.

The routing of the original tone signal out of the Service Monitor, and the revertive tone signal into the Service Monitor, is dependent on the settings of the [*Tones In*] and [*Tones Out*] keys on the TONES selection screen. This allows the permutations shown in the following table.

Original tones out	Revertive tones in
RF	RF
RF	AF
AF	RF
AF	AF

The revertive tones operation is configured by pressing the [*Revertv Tones*] key. To send a tone burst, do one of the following:

- If TONE BURST has NOT already been selected as the send mode, press the [*Send Mode*] key to access the send mode menu, then press the [*Tone Burst*] key. The tone sequence will be generated, then after the last tone, the Service Monitor will change to decode mode ready to decode the revertive tones.
- If TONE BURST has already been selected as the send mode, press the orange [ON/OFF] function key. The tone sequence will be generated, then after the last tone, the Service Monitor will change to decode mode ready to decode the revertive tones.

The encoder screen can be displayed again by pressing the [*Encode*] key.

## CTCSS

The CTCSS tones system uses a continuous tone at a precise frequency, transmitted below the audio pass band, to un-squelch the receiver.

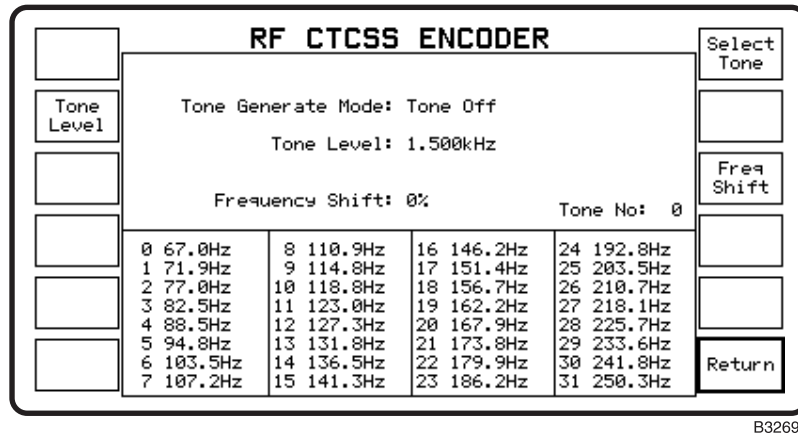

Fig. 3-21 RF CTCSS encoder screen and menu

Pressing the [CTCSS] key on the TONES selection screen will display the screen shown in Fig. 3-21, RF CTCSS encoder screen and menu.

The CTCSS function of the Service Monitor will generate a single AF tone, selected from those listed on the display.

## Output level

The required output level of the tone signal can be set using the data entry keys, after highlighting the legend **Tone Level** by pressing the [Tone Level] key.

The units used to specify the output level will relate to the selected output routing and, when RF output is selected, the modulation method. The modulation type is automatically set, to be appropriate to the level terminator key used (FM for Hz, kHz or MHz; AM for %).

The valid output range for each output option is shown in the following table.

Output type	Output range	Default
RF AM	0-99%	30%
RF FM	0-75 kHz	1.5 kHz
Audio	100 $\mu$ V-4 V	100 mV

## Tone selection

The required tone is selected from the table in the lower part of the display. Press the [Select Tone] key to highlight the legend **Tone No.** Use the data keys to enter the number of the required tone, then press the [ENTER] key.

## Tone frequency shift

The frequency of the selected tone can be shifted by up to  $\pm 10\%$ . Press the [Freq Shift] key to highlight the legend **Frequency Shift**. Use the data keys to enter the value of frequency shift required. Only whole numbers within the above range are valid. Complete the entry with the [%] key.

## Tone ON/OFF control

When the RF CTCSS ENCODER screen or the AF CTCSS ENCODER screen is displayed, the tone is turned on or off by the orange [ON/OFF] function key.

If the CTCSS tone is ON and the Tx TEST, Rx TEST, Dx TEST or AF TEST mode selected, the CTCSS tone will continue to be generated.

If the tones out routing has been set to give RF tones, this is provided by modulation generator 2. The legend --CTCSS-- will be displayed against MOD2 FREQ on the RECEIVER TEST or DUPLEX screens. If MOD2 is selected, the CTCSS tones can be controlled by repeated presses of the orange [ON/OFF] function key. If MOD2 FREQ is selected, the CTCSS tone is still controlled by the [ON/OFF] key, but if a frequency is entered using the data keys or if the variable control is adjusted, the CTCSS tone will cease. It can then be re-started only when the RF CTCSS ENCODER screen or the AF CTCSS ENCODER screen is displayed.

If the tones out routing has been set to give AF tones, this is provided by audio generator 2. The legend --CTCSS-- will be displayed against AF2 FREQ on the TRANSMITTER TEST, DUPLEX or AF TEST screens. If AF2 is selected, the CTCSS tones can be controlled by repeated presses of the orange [ON/OFF] function key. If AF2 FREQ is selected, the CTCSS tone is still controlled by the [ON/OFF] key, but if a frequency is entered using the data keys or if the variable control is adjusted, the CTCSS tone will cease. It can then be re-started only when the RF CTCSS ENCODER screen or the AF CTCSS ENCODER screen is displayed.

## DCS

### Overview

Digitally Coded Squelch signaling is a system for addressing mobile radio transceivers from their base station by transmitting a code unique to the addressed transceiver for the duration of the transmission. The principles and limitations of the system provide 104 uniquely identifiable codes for use on any one RF channel.

The coded signal consists of a repeating 23 bit word that has error correcting information and timing using 14 bits, leaving nine bits available to carry address code.

The digital signal is formatted as a simple non-return to zero (NRZ) signal, which is used to directly modulate the transmitter. On frequency shift modulating systems a '1' is usually made to increase the carrier frequency and a '0' to decrease the carrier frequency. An 'Invert' facility is included to reverse the polarity of the digital signal before it is applied to the modulator.

The most often used bit rate for generating the 23 bit code words and that which is specified in most standards is 134 bits/s. This allows the system to operate below the communications audio pass band.

See [Signal routing](#) and [RF input attenuators](#) starting on page 3-70.

## DCS receiver decoder testing

To test the DCS decoder function of a mobile transceiver, set up and connect the Service Monitor with the mobile as described in the Rx testing section earlier in this chapter.

Access the DCS facility within the RF tones mode by using the sequence, *[Tones]*, *[DCS]*. The RF DCS Encoder screen and menu is displayed as shown in Fig. 3-22, *RF DCS ENCODER screen and menu*.

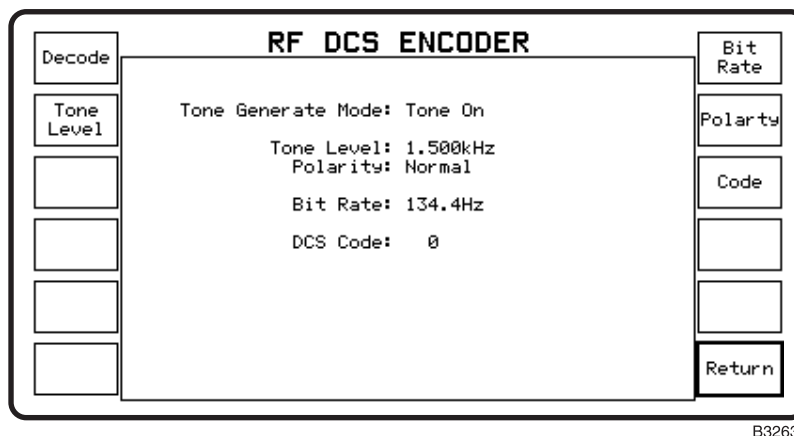

B3263

Fig. 3-22 RF DCS ENCODER screen and menu

Check that the bit rate is correct for the unit to be tested. If a different bit rate is required to that which is shown on the display, enter the required value as follows.

Press the *[Bit Rate]* key to highlight the **Bit Rate** legend on the display. Use the data entry keys to enter the correct value and press the Hz terminator key. *Note. The most common bit rate for DCS systems is 134 bits/s.*

Check that the tone (modulation) level is correct for the system specification. If a different level is required to that which is shown on the display, enter the required value as follows:

Press the *[Tone Level]* key to highlight the **TONE LEVEL** legend on the display. Use the data entry keys to enter the correct value and press the [kHz] or [Hz] terminator key as appropriate. *Note. The level of modulation for DCS signal modulation is usually within the range 10% to 20% of the system maximum level.*

Check the modulation polarity of the transceiver. For positive modulation the polarity should be set to **Normal** and for negative modulation, set to **Inverted**.

The *[Polarity]* key toggles between these two options.

To enter or change the DCS code for the transceiver to be tested, first press the *[Code]* key to highlight the legend **DCS Code**. Key in the code using the data entry keys. The Service Monitor will accept any octal sequence in the range 0 to 777.

Complete the entry by pressing the [Enter] key. Leading zeros will be suppressed.

Return to the Rx TEST mode and check that the RF generator is active, then return to the TONES, DCS mode. The DCS coded signal will be produced when the legend Tone On is displayed against Tone Generate Mode:. See *Tone ON/OFF control* below.

### Tone ON/OFF control

When the RF DCS ENCODER screen or the AF DCS ENCODER screen is displayed, the tone is turned on or off by the orange [ON/OFF] function key.

If the DCS tone is ON and the Tx TEST, Rx TEST, Dx TEST or AF TEST mode selected, the CTCSS tone will continue to be generated.

If the tones out routing has been set to give RF tones, this is provided by modulation generator 2. The legend ---DCS--- will be displayed against MOD2 FREQ on the RECEIVER TEST or DUPLEX screens. If MOD2 is selected, the DCS tones can be controlled by repeated presses of the orange [ON/OFF] function key. If MOD2 FREQ is selected, the DCS tone is still controlled by the [ON/OFF] key, but if a frequency is entered using the data keys or if the variable control is adjusted, the DCS tone will cease. It can then be re-started only when the RF DCS ENCODER screen or the AF DCS ENCODER screen is displayed.

If the tones out routing has been set to give AF tones, this is provided by audio generator 2. The legend --DCS-- will be displayed against AF2 FREQ on the TRANSMITTER TEST, DUPLEX or AF TEST screens. If AF2 is selected, the DCS tones can be controlled by repeated presses of the orange [ON/OFF] function key. If AF2 FREQ is selected, the DCS tone is still controlled by the [ON/OFF] key, but if a frequency is entered using the data keys or if the variable control is adjusted, the DCS tone will cease. It can then be re-started only when the RF DCS ENCODER screen or the AF DCS ENCODER screen is displayed.

### DCS transmitter encoder testing

The decoders within transceivers equipped with DCS signaling are usually programmed to generate their code for inclusion on the reverse channel.

The DCS RF decoder function of this Service Monitor is able to demodulate the DCS signal and display the digital data.

The DCS signal is fed into a comparator register and occurrences of bit patterns corresponding to the three 'fixed bits' 0 0 1, of the coded signal are flagged.

23 bit samples of the coded signal are placed in registers with the occurrences of the 0 0 1 sequence occupying the 12, 11 and 10 bit positions. The value of the data in bit positions 1 to 9 is decoded. This corresponds to the DCS code number.

The binary representations of all the decoded sequences are displayed, along with the DCS code. The oct values are compared with the system permitted codes in a look-up table and the true code indicated.

The user can select the decoder bit rate to match that of the system, within the range 100 bits/s to 200 bits/s. The modulation level of the data signal is shown on the display.



## DTMF

### Overview

Dual Tone, Multi-Frequency.

The DTMF tones function will generate and decode sequences, of up to 40 characters corresponding to the standard DTMF frequencies.

The encoder allows the user to create characters sequences, which are routed to the AF GEN OUTPUT connector or to the RF generator modulators.

The decoder will accept up to 40 tone pairs, either from the modulation meter output or as AF signals from the AF INPUT connector.

### Tx test DTMF tones function

In the Tx TEST mode, with *[Tones In]* set to , DTMF tones generated within the mobile under test, are recovered from the RF signal and routed to the DTMF decoder.

The RF frequency and modulation type of the transmitter under test is set up from the Tx TEST mode.

Pressing the *[Tones]* key will display the screen shown in fold out diagram (2-5). The *[DTMF]* key will then give access to the RF DTMF DECODER screen shown in Fig. 3-23, *RF DTMF DECODER screen and menu*.

The decoder measures the frequencies and duration of each tone pair, identifies the character, and calculates any frequency errors. The results of this are listed on the display as shown.

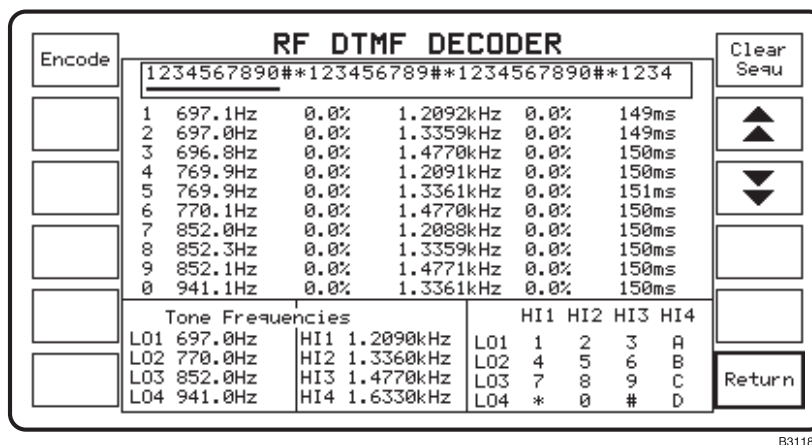

B3118

Fig. 3-23 RF DTMF DECODER screen and menu

The bottom of the screen contains two tables. The tone frequencies table on the left lists the eight frequencies, LO1 to LO4 and HI1 to HI4, used for DTMF signaling. The table on the right shows the 16 digit/character/symbol keypad with the LO tones and HI tones matrix.

The panel at the top of the display area shows the contents of the DTMF decoder memory. A maximum of 40 symbols can be stored, any additional symbols will not be accepted.

The central area of the display, which is blank when first accessed, lists the measured frequencies of ten of the received tones. The underscore in the decoded character panel of the display indicates which characters are listed. The left hand column shows the measured frequencies of the 'LO' tones with the percentage error, the center column the corresponding 'HI' tones with error, while the right hand column shows the duration of each tone.

To display the next 10 decoded results, press the *[↓]* key. To display the previous 10 decoded results, press the *[↑]* key.

The display can be printed.

To clear the contents of the decoder memory press the *[Clear Sequ]* key. **Once cleared, they cannot be retrieved.**

## Rx test DTMF tones function

In the Rx TEST mode, with *[Tones Out]* set to , the encoder output is fed to the RF generator and the tones used to modulate the RF signal. The DTMF decoder within the receiver under test can then be tested.

When setting up the Service Monitor to test the DTMF decoder of a receiver, commence as for normal Rx tests. When all settings are correct, disable the modulation generators by using the key sequence *[Mod Gen]*, *[Gen 1/Gen 2]*, *[OFF/ON]*, as appropriate, then the RF generator by using the *[RF GEN]*, *[LEVEL]*, *[ON/OFF]* key sequence.

Press the *[Tones]* key to display the screen shown in fold out diagram (3-5). The *[DTMF]* key will then give access to the RF DTMF ENCODER screen.

## Formatting a tone sequence

To create the required tone sequence, first press the *[Enter Sequ]* key to display the cursor in the tone sequence panel. If the tone sequence panel is not empty use the *[DELETE]* key to clear the sequence.

Enter the required sequence by using any of the 16 available characters of the DTMF keypad. Pressing the equivalent data key on the front panel will cause the character to be entered in the sequence panel. The cursor then moves to the next position and a second character can be entered.

Any number of Null Tones can be included in a tone sequence. A Null Tone is a silent period, and has a duration of one tone period. It is indicated in the tone sequence panel by a dash (—) To enter a Null Tone in a tone sequence, press the *[Null Tone]* key once.

A maximum of 40 characters can be included in a sequence, any further entries will over-write the existing sequence.

## Editing a tone sequence

An existing tone sequence can be edited as required. Using the rotary control, move the cursor over the character to be changed. To delete the unwanted character and insert a new character in its place, press the data key corresponding to the new character. To delete an unwanted character and close up the sequence, press the *[DELETE]* key.

### Tones modulation level

The modulation level produced by each tone of the tone pair can be set independently.

Pressing the *[Lo Tone Level]* key will highlight the legend **Lo Tone Level**. The modulation level can then be set using the data entry keys.

The modulation level produced by the tones is set using the *[Lo Tone Level]* or *[Hi tone Level]* key, followed by use of the data input keys. The modulation level limits are 25 Hz to 75 kHz FM or 1% to 99% AM. Attempted entries outside of the values will be ignored. The default level is 1.5 kHz.

The modulation level produced by each tone of the tone pair can be set independently. Levels of the two tones can be locked using the *[Lock Levels]* key. This key toggles between the locked and unlocked condition. When going from unlocked to locked, the latest level set will be taken by both tones.

The tone duration and the pause duration, (time between each tone) can each be set independently, from 20 ms to 1.0 s. The default values are 150 ms duration and 50 ms pause.

A tones frequency shift facility is provided for testing decoder circuits. To shift the frequency of the transmitted tones press the *[Freq Shift]* key to highlight the **Frequency Shift** legend on the display and enter the percentage value of the shift required using the data entry keys. Frequency increases or decreases are possible. Entering a negative value will cause the transmitted frequencies to be decreased from the stated frequency. The maximum frequency shift is 10%.

When the DTMF TONES functions are set, return to the Rx TEST mode and enable the RF generator. Return to the DTMF RF ENCODER function. Press the *[Send Mode]* key to display the Send Mode menu. The options available are:

*[Cont Tones]* Generates the tone sequence repeatedly until the orange [ON/OFF] function key is pressed.

*[Tone Burst]* Generates one sequence of the tones then stops.

*[Step Tones]* The first press causes the first tone of the sequence to be generated for the duration specified. When the *[Step Tones]* key is pressed again, the next tone in the sequence will be generated for the duration specified.

*[Single Tone]* After pressing this key, pressing any data entry key will cause the corresponding tone to be generated for the duration specified.

Using the appropriate keys to send the selected tones to the receiver, tests can be made to the DTMF decoder.

### Dx test DTMF tones function

When in Dx test mode the DTMF tones function can be accessed by pressing the *[Tones]* key. The user can select encode or decode. The encode function will produce tones for mobile receiver testing and decode will interpret tones produced by a mobile transmitter. The encoder and decoder cannot operate simultaneously.

### AF test DTMF tones function

The use of the DTMF tones function within the AF test mode allows the Service Monitor to produce DTMF tones for direct injection into the DTMF decode circuits of mobiles or other equipment.

The decoder will analyze DTMF tones produced within mobiles and other equipment.

The DTMF tones are obtained from the AF output connector on the front panel. The output levels and impedances are as for the AF generator output.

The input to the DTMF decoder within the Service Monitor is through the AF input connector. The decoder will respond to signal levels above approximately 150 mV rms.

## Tones ON/OFF control

When the RF DTMF ENCODER screen or the AF DTMF ENCODER screen is displayed, the tone is turned ON or OFF by the orange [ON/OFF] function key.

If the DTMF tone is ON and the Tx TEST, Rx TEST, Dx TEST or AF TEST mode selected, the DTMF tone will continue to be generated.

If the tones out routing has been set to give RF tones, these are provided by modulation generators 1 and 2. The legend --Tones-- will be displayed against both MOD1 FREQ and MOD2 FREQ on the RECEIVER TEST or DUPLEX screens. If **MOD1** or **MOD2** is selected, the DTMF tones can be controlled by repeated presses of the orange [ON/OFF] function key. If **MOD1 FREQ** or **MOD2 FREQ** is selected, the DTMF tones are still controlled by the [ON/OFF] key, but if a frequency is entered using the data keys or if the variable control is adjusted, the DTMF tones will cease. They can then be re-started only when the RF DTMF ENCODER screen or the AF DTMF ENCODER screen is displayed.

If the tones out routing has been set to give AF tones, this is provided by audio generators 1 and 2. The legend --Tones-- will be displayed against both AF1 FREQ and AF2 FREQ on the TRANSMITTER TEST, DUPLEX or AF TEST screens. If **AF1** or **AF2** is selected, the DTMF tones can be controlled by repeated presses of the orange [ON/OFF] function key. If **AF1 FREQ** or **AF2 FREQ** is selected, the DTMF tones are still controlled by the [ON/OFF] key, but if a frequency is entered using the data keys or if the variable control is adjusted, the DTMF tones will cease. They can then be re-started only when the RF DTMF ENCODER screen or the AF DTMF ENCODER screen is displayed.

## POCSAG

### Overview

The POCSAG system is an international standard for radio pager operation. The system operates by broadcasting digital messages on a common frequency, only alerting the addressed radio pager when the transmitted address matches that of the pager. The signal transmitted consists of two main elements, the address and the message.

The POCSAG test facility within the Service Monitor generates a paging signal containing all elements of a 'live' signal. This signal is transmitted using the RF generator output to feed a suitable test rig or TEM cell.

The decoder test facility allows a POCSAG type encoded signal to be decoded and displayed.

To access the POCSAG test facility use the following key sequence:

[Rx TEST], [Tones], [POCSAG].

The screen and menu shown in Fig. 3-24, *POCSAG radio pager test screen and menu*, will be displayed.

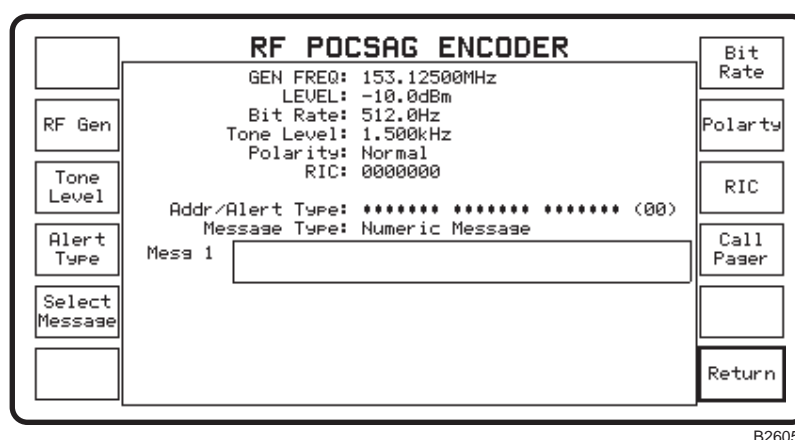

Fig. 3-24 *POCSAG radio pager test screen and menu*

The facilities offered by this Service Monitor for testing radio pagers are:

- The RF generator of the Service Monitor can be set to any frequency within the specified range of the Service Monitor. The default frequency is 153.125 MHz.
- The RF level can be set to any level within the normal operating level of the Service Monitor.
- The modulation level of the signal can be to any level within the normal operating level of the Service Monitor. The default level is 1.5 kHz.
- The Address and Alert warning type can be set to any of the four available. The alert message generated by radio pagers can be selected from four formats. The selection is controlled by two function bits within the transmitted address codeword. The Service Monitor displays a representation of the audible alert message, shows the relevant function bit combination, and describes the type of message that is transmitted after the particular alert message. See Fig. 3-25, *Alternative address/warning messages*.

The Service Monitor has 7 different inbuilt messages, which can be sent to the radio pager. These messages are selected by repeated presses of the [Select Message] key. The selected message is shown in a panel on the display with the legend MESS 1 (or Mess 2 etc.).

The bit rate of the transmitted test signal can be set by the user within the limits 400 Hz to 4.8 kHz. The default bit rate is the standard system bit rate of 512 Hz.

The generated data can be transmitted with normal or inverted polarity.

## LOCAL OPERATION

The radio identification code (RIC) of the radio pager is set by the user. This is entered into the Service Monitor as a seven digit decimal number corresponding to the 21 bit address code of the radio pager. The number is unique to the radio pager and will have a maximum decimal equivalent of 2097151.

**Note**

Leading zero can be omitted from the entry of RIC to save time.

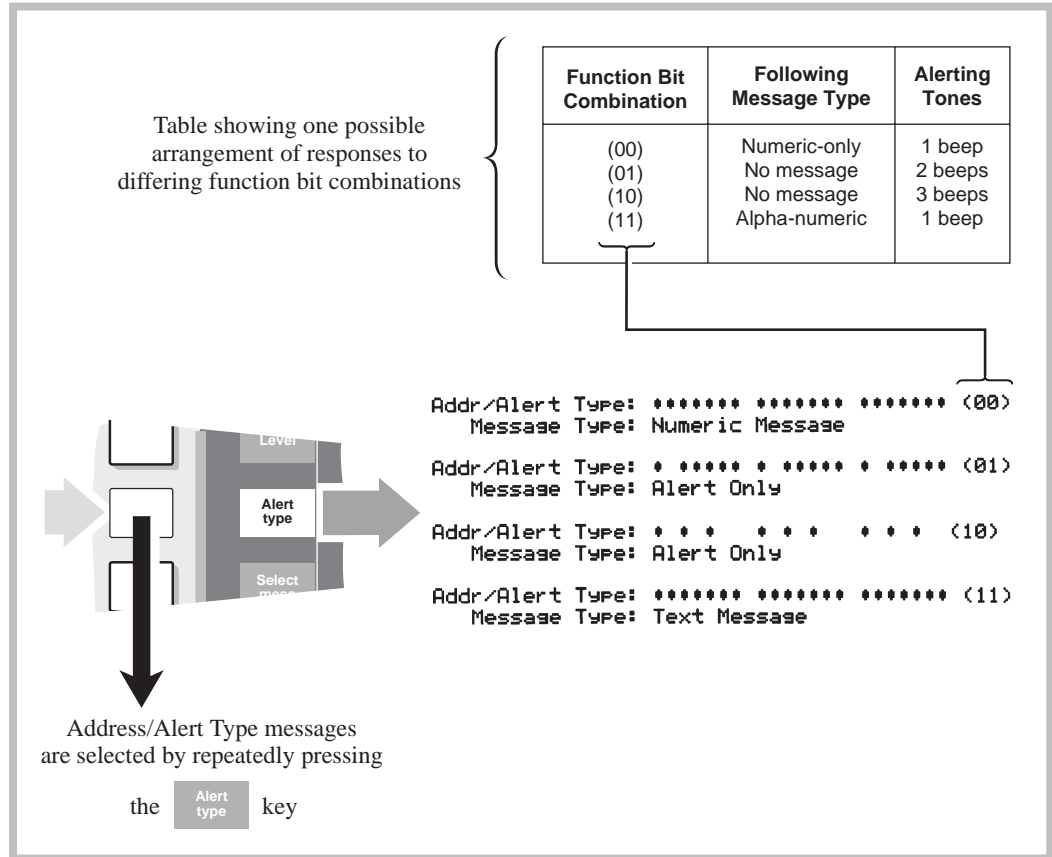

C1883

*Fig. 3-25 Alternative address/warning messages*

## Testing a radio pager

Radio pagers are self-contained units with no external antenna provision, therefore it is not possible to make a direct RF connection between the Service Monitor and the pager. The Service Monitor output can be taken from the BNC RF output connector using the telescopic antenna accessory (part no. 54421/001) or similar, where suitable screening is available. Alternatively, a TEM cell may be preferable.

To configure the Service Monitor to make operational tests to a radio pager proceed as follows:

- Select the POCSAG option from the Rx TEST mode, TONES function.
- Set the RF generator frequency to match the pager system operating frequency. Press the *[RF Gen]* key to highlight the GEN FREQ: legend on the display. Enter the required frequency using the data input keys.
- Set the RF output level to a suitable value by pressing the *[RF Gen]* key followed by the orange [LEVEL] key to highlight the GEN and LEVEL: legends on the display. Use the data input keys to enter the RF level.
- Set the modulation level to match the specification of the system to which the pager is assigned. Press the *[Tone Level]* key to highlight the **Tone Level:** legend on the display. Enter the required modulation level using the data input keys.
- Set the bit rate to match the specification of the system to which the pager is assigned. Press the *[Bit Rate]* key to highlight the **Bit Rate:** legend on the display. Enter the value of the required bit rate as a frequency using the data input keys, terminated by [Hz].
- If the system requires the transmitted data to have an inverted format, press the *[Invert]* key to make the legend beside the Polarity: legend on the display read Inverted. The *[invert]* key toggles the legend between Inverted and Normal.
- Set the RIC (Radio Identification Code), to match that of the pager. Press the *[RIC]* key to highlight the legend **RIC** on the display and enter the required number using the data entry keys, followed by [ENTER]. An attempt to enter a number that exceeds the range of the system maximum will not be accepted and the previously displayed **RIC** will be retained.

The Service Monitor is now configured to produce a signal compatible with the radio pager. With the radio pager powered up and located as mentioned above, press the *[Call Pager]* key. The radio pager will respond.

To test the differing response options of the radio pager the user can select the combination of function bits and the contents of the message transmitted.

The Function bits are changed by repeated presses of the *[Alert/Type]* key. See Fig. 3-24, *POCSAG radio pager test screen and menu*, above.

The message content of the signal can be selected from 7 options by repeated presses of the *[Select Message]* key. Message 1 contains no data and thus produces an alert only response from the radio pager.

The parameters of the test signal can be varied within the limits mentioned in *Facilities* above, to test the performance tolerances of the radio pager.

## Oscilloscope

The digital oscilloscope option is available from within the Tx TEST, Rx TEST and AF TEST modes. There are two display functions:

The standard display with a viewing area of approximately 38 × 65 mm.

The expanded display with a viewing area of approximately 63 × 90 mm.

The oscilloscope display may or may not be shown when the Tx TEST, Rx TEST or AF TEST modes are selected. This is dependent on the last use of the selected test mode, and the selection made using the *[Power Up From]* key on the Setup page ([HELP/SETUP] key followed by *[Setup]*).

To access the oscilloscope function from a bar chart display, press the *[Scope/bar]* key: the first press will show the standard display, the second press will show the expanded display, the third press will return to the bar chart display.

## Setting up

The Y sensitivity and the timebase ranges of the oscilloscope are set from the right hand soft keys. The current settings are shown above the oscilloscope display.

When in Rx TEST and AF TEST modes, the Y (vertical) input is by the AF input connector. The Y sensitivity is switchable in a 1, 2, 5 sequence, from 10 mV/division to 20 V/division. The [AC/DC] key selects AC or DC coupling into the oscilloscope.

When in Tx TEST mode, the Y input is taken directly from the modulation meter output. The Y axis is calibrated to display modulation level. FM ranges are from 0.5 kHz/division to 25 kHz/division. AM ranges are 5%/division, 10%/division and 20%/division.

The horizontal timebase has ranges of 100 μs/division to 5 s/division in a 1, 2, 5 sequence.

The soft keys have the following functions, (top to bottom):

<i>[▲]</i>	Increases Y Sensitivity by one range per key press.
<i>[◆]</i>	Decreases Y Sensitivity by one range per key press.
<i>[▶▶]</i>	Increases Time/Division by one range per key press.
<i>[◀◀]</i>	Decreases Time/Division by one range per key press.
<i>[Scope/Bar]</i>	Steps to Expanded display or Bar chart display
<i>[Return]</i> (Standard)	Returns display and menu to Tx TEST, Rx TEST or AF Test.
<i>[Persistence]</i> (Expanded)	Steps persistence setting through Off, Low Med High Inf.

The vertical position of the oscilloscope trace can be adjusted using the POSITION rotary control.

The horizontal sweep trigger can be set for repetitive or single sweep, set by the scope mode keys (Item 15 on Fig 3-1, *Front panel*).

With repetitive mode selected, the trace will free-run, re-triggering on the positive-going edge of the signal, at the end of each sweep. In the absence of a signal the trace will auto-trigger.

With single sweep selected, the first positive going signal will trigger a sweep. The [SINGLE] key must be pressed to re-arm the trigger circuit before another sweep can be triggered.



### Expanded display

With the expanded display selected, the area of the display available for digital readings is limited. The following table shows the data that can be displayed in each test mode.

Tx Test	Rx Test	AF Test
Tx FREQ OFFSET POWER MOD FREQ FM/AM LEVEL SINAD, S/N, DISTORTION	AUDIO FREQ LEVEL SINAD, S/N, DISTORTION	AUDIO FREQ LEVEL SINAD, S/N, DISTORTION

### Persistence

The persistence of the scope trace can be selected to suit the user's requirements. The expanded display has a [*Persistence*] key, which steps through the available persistence settings. The persistence setting is effective on both the expanded and standard oscilloscope displays but can only be set from the expanded display.

The following table shows the available settings and the approximate decay times.

Setting	Decay time (seconds)
Off	0
Low	1
Med	3
High	8
Inf	Infinite

## Stores, settings/results

### Overview

A section of the non-volatile RAM in the Service Monitor is designated as a user store for instrument settings and results. 'Power Down' and 'Factory Pre-set' settings are also held in this area of memory.

There are two routes through which the user memory can be accessed, depending on the action to be performed.

To recall data from memory or to store settings, press the orange [MEM] key. This will display the STORE/RECALL screen and menu.

To store test results or bit-maps of test screens, first press the [DISPLAY HOLD] key. The soft key menu will change to show a [Print] key and a [Store] key. Pressing the store key will display the DISPLAY HOLD STORE screen and menu.

### STORE/RECALL

To store settings or to recall data from memory proceed as follows:

Press the orange [MEM] key. The STORE/RECALL screen and menu is displayed. A message, '*Recall from Store No.*' is shown, flashing in inverse video.

A sub-heading 'INTERNAL STORE' is shown above a list of the store locations, with addresses from 00 to 09. A line of details relating to each store is shown against each address.

Store location 00 is followed by the information;

'P Settings Power Down Store'.

This location holds the settings of the Service Monitor when power was last switched off.

The 'P' shows that the data is protected, it cannot be over-written or deleted.

'Settings' shows that the data is a set of instrument settings.

'Power Down Store' is a title identifying the contents.

Similarly store location 01 contains the factory default settings.

### Recalling

To recall the contents of a store location, proceed as follows:

Press the [Recall] key to display the inverse video message, '*Recall Store No.*' if it is not already displayed.

Key in the two digit address of the location, using the data entry keys.

### Recalling Settings

Entering '00' or '01' will recall the settings described above.

When 'Settings' are recalled, the Service Monitor will set to the mode that was current when the settings were saved.

Take care after recalling 'settings', as selections such as RF IN/OUT [SELECT], incremental settings and bar chart ranges are included.

#### Note

**The addressing procedure of all memory functions is similar. The flashing, inverse video message describes the action that will happen when a location address is entered, and requests a two digit store address. The first digit entered appears beside the message, but the second digit of the address implements the action.**

### Recalling Results

When 'Results' are recalled, the RESULTS SCREEN is displayed. The test results are shown against each of the parameter headings. Results of tests made when in the Dx TEST mode are shown with the RECEIVER TEST results in the top half of the display and the TRANSMITTER TEST results in the bottom half.

## Storing

### Storing settings

To store settings, make sure that all the parameters, selections, bar chart ranges and other settings, relevant to the intended work, are set as required. Then proceed as follows:

Press the orange [MEM] key and the STORE/RECALL screen will be displayed. Ignore the flashing inverse video message.

Press the *[Store Setting]* key, which will cause the flashing inverse video message to change to, *'Store Settings To Store No.'*

Key in the two digit address of the required empty or unprotected location. Any data already contained in the location will be overwritten.

The location address list will show the contents of the location as 'Settings'.

A unique title can be attached to the store location. See ['Titling store locations'](#) later.

## DISPLAY HOLD STORE

### Storing results

Results obtained using the Tx, Rx, Dx, and AF test modes can be stored. For this, the memory is accessed using the [DISPLAY HOLD] key.

To store test results, make the required test, and when the display shows the results to be stored, proceed as follows:

Press the [DISPLAY HOLD] key. The current soft key menu will be replaced to show two keys, *[Print]* and *[Store]*.

Press the *[Store]* key, which will cause the DISPLAY HOLD STORE screen to be displayed, with a flashing inverse video message *'Store Results To Store No.'*

Key in the two digit address of the required empty or unprotected location. Any data already contained in the location will be overwritten.

The location address list will show the contents of the location as 'Results'.

A unique title can be attached to the store location. See ['Titling store locations'](#) later.

## Other memory functions

Other memory functions can be carried out from either the STORE/RECALL or DISPLAY HOLD STORE screen and menu.

### Protecting store contents

The contents of any store location can be protected from being over-written or deleted.

To protect a store location, Proceed as follows:

Press the *[Protect Store]* key. The inverse video message, *'Protect Store No.'* is displayed.

Key in the two digit address of the location to be protected, using the data entry keys. A 'P' will be shown against the location address in the list.

Any attempt to over-write or delete the contents of the location will cause the message *'\*\*\*ERROR Store protected \*\*\*'* to be displayed momentarily.

To remove the protection from a location, use the same procedure used to protect the location. The 'P' will be removed from the location address.

### Deleting store contents

To delete the contents of an unprotected store location, proceed as follows:

Press the *[Delete]* key. The inverse video message, 'Delete Store No.' will be displayed.

Key in the two digit address of the location to be deleted, using the data entry keys. The contents will be deleted as soon as the second digit is keyed and the location address list will show the location as 'Empty'.

Once deleted, the contents cannot be retrieved.

<b>Note</b>
-------------

**Store locations 00 and 01 which contain 'Last Power-down' and 'Factory Preset' settings respectively, cannot have their protection removed or be deleted.**

### Titling store locations

Store locations can be titled from either the STORE/RECALL screen and menu or the DISPLAY HOLD STORE screen and menu. Titles can be up to 20 characters long, including any spaces.

Press the *[Enter Title]* key. The inverse video message, 'Title Store No.' will be displayed. Key in the address of the store location to be titled. The soft key menu will change to show the following keys:

*[▲]*, *[▼]*, *[Enter Char]*, *[Title Complet]* and *[Return]*.

A line of letters, digits and symbols is shown at the bottom of the display. An inverse video cursor, which can be controlled using the variable control, highlights a selected character on the line. A similar cursor is shown in the title area of the location address.

The selected Character is entered into the title area of the location address list by pressing the *[Enter Char]* key. Subsequent characters are entered in the same way.

Errors can be corrected by using the *[←]* or *[→]* keys to place the cursor over the incorrect character and then inserting the correct character.

When the title is complete, press the *[Title Complet]* key. The normal STORE/RECALL screen or DISPLAY HOLD STORE screen will be displayed.

A title can be changed or corrected at any time using the titling procedure.

### Error messages

There are a number of error messages associated with the store facility, which will be displayed, for approximately 10 seconds, under certain conditions. These are listed below.

\*\*\* *ERROR Store Empty* \*\*\* The recalled store location is empty.

\*\*\* *ERROR Store Protected* \*\*\* The store addressed is protected and therefore cannot be overwritten or deleted.

\*\*\* *ERROR Cannot Print Store* \*\*\* The contents of the store cannot be printed. The addressed store location is an internal store.

## Printer

An RS232 printer can be driven by the Service Monitor when connected to the SERIAL PORT on the rear panel. Complete screen images and hard copy of stored test results can be printed.

The serial port must be set to the printer option through the [HELP/SETUP], [Setup] key sequence, followed by the [Remote Control] key. The port must be configured to match the requirements of the printer using the port configuration menu also accessible through the [HELP/SETUP], [Setup] key sequence, followed by the [Serial Setup] key.

To print screen images, make the required test, and when the display shows the data to be printed, proceed as follows:

Press the [DISPLAY HOLD] key. The current soft key menu will be replaced to show two keys, [Print] and [Store].

Press the [Print] key. The display will be reproduced by the printer.

Test results held in the Service Monitor memory stores can also be printed. The procedures for these operations are described earlier in this chapter. See *Stores, settings/results*, on page 3-90.

## Parallel printer port option

### Parallel output

The parallel printer port option provides an output suitable for direct connection to a parallel drive printer. Fig. 3-26, *Parallel printer port socket contacts*, shows the pin numbering of the socket and Table 3-1, *Parallel printer port connections*, shows the function of the socket connections.

### Pin connections



Fig. 3-26 *Parallel printer port socket contacts* (as seen facing panel)

**Table 3-1 Parallel printer port connections**

Contact Function	Contact	Function	
1	Strobe	10	ACK
2	Data 0	11	BUSY
3	Data 1	12	PE
4	Data 2	13	SLCT
5	Data 3	14	to +5 V via R
6	Data 4	15	ERROR
7	Data 5	16	to +5 V via R
8	Data 6	17	to 0 V via R
9	Data 7	18 to 25	Ground

**Accessory port (rear optional)**

As well as the parallel printer output, this option also provides an accessory port that allows the control of external devices by logic control from the instrument. Fig. 3-28, *Rear accessory port socket connections*, shows the pin numbering of the socket and Table 3-2, *Rear accessory port connections*, shows the function of the socket connections. Fig. 3-27, *Simplified diagram of rear accessory port switching* shows the switching associated with the port.

Switches 1(a) to 1(d) are parts of a multi-pole rocker switch, mounted on the printed circuit board within the option assembly. By setting these switches, the user has the option of logic level output on the appropriate pins or of closing contacts between pairs of pins.

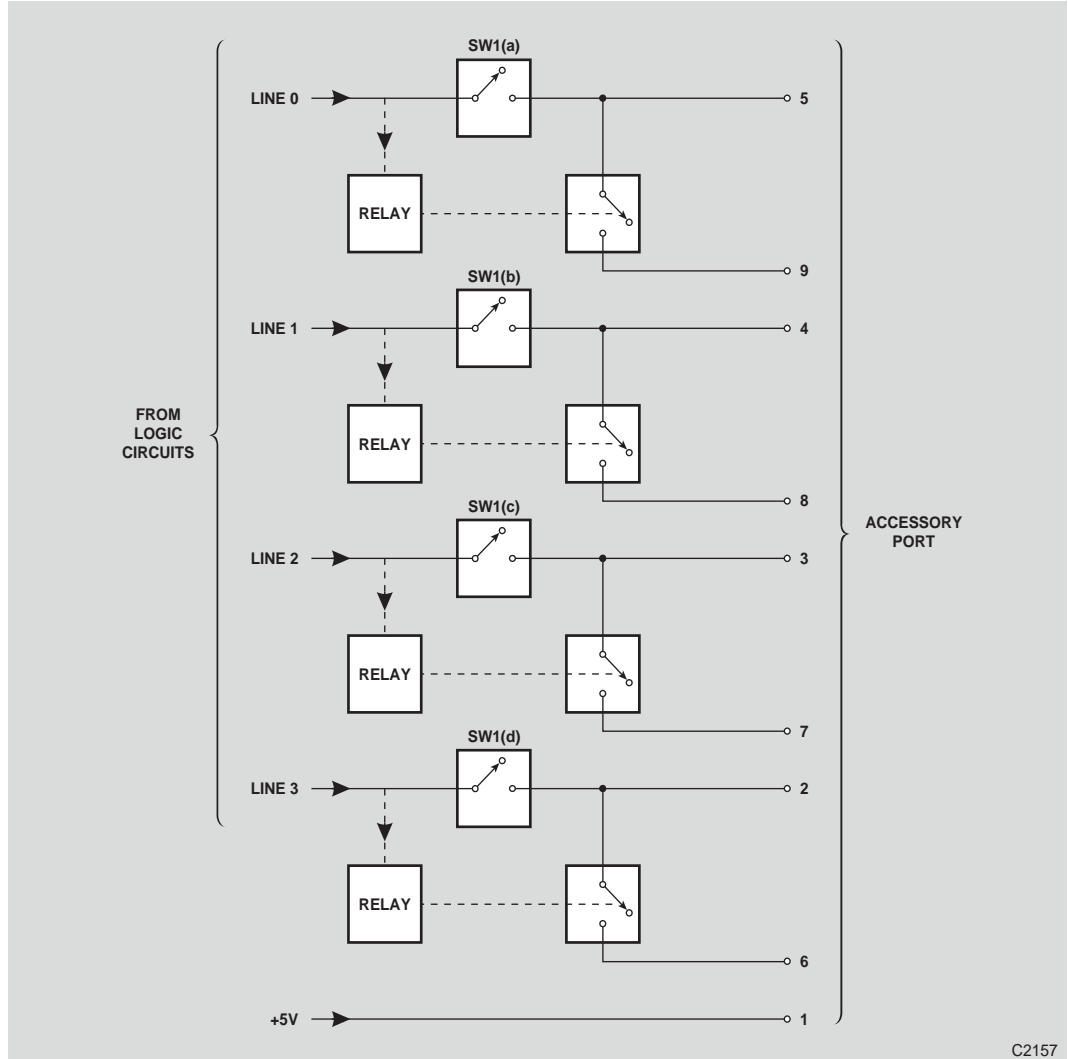

Fig. 3-27 Simplified diagram of rear accessory port switching

**Pin Connections**

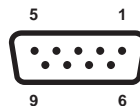

Fig. 3-28 Rear accessory port socket connections (as seen facing panel)

**Table 3-2 Rear accessory port connections**

Contact	Function
1	+5 V
2	Logic line 3 or logic contact 3(a)
3	Logic line 2 or logic contact 2(a)
4	Logic line 1 or logic contact 1(a)
5	Logic line 0 or logic contact 0(a)
6	logic contact 3(b)
7	Logic contact 2(b)
8	Logic contact 1(b)
9	Logic contact 0(b)

## Setting up

### Logic line state

The state of the logic lines outputs can be set from the logic lines setup menu, accessible by the key sequence, [HELP/SETUP], [Setup], [Logic Lines].

The top four soft keys on the right of the display control the normal state of the logic lines. Pressing these keys will set the options alternately.

If the appropriate section of S1 is closed, the output can be set to either logic high or logic low. If the appropriate section of S1 is open, the contacts between pin pairs can be set to opened or closed. Switch S1 is mounted within the option assembly, on the printed circuit board. The option assembly must be removed from the service monitor to have access to S1. Remove the power connection from the service monitor, and any connections from the option assembly before removing it from the service monitor. After making changes to S1, refit the option assembly to the service monitor before re-connecting the power lead. Each of the four lines can be set individually.

When any section of S1 is closed, and the connector output of that line (pins 2,3,4 or 5) is at a logic state high, the associated pin (6,7,8 or 9) will also be at logic state high.

When any section of S1 is open, and the connector output of that line (pins 2,3,4 or 5) is at a logic state low, the associated pin (6,7,8 or 9) will be open circuit.

### Logic line control

Additional control is provided to logic lines 0 and 1, from the two top soft keys on the left of the logic line setup menu.

When set to 'As setting', the output will be as set by the right-hand soft keys.

When the 'Line 0 Mode' is set to 'Close for Transmit', the state of this line will depend upon which operating mode the instrument is set to.

When the instrument is in the Rx TEST mode, line 0 will take up the 'Closed/Logic High' state, and the 'Open/Logic Low' state for all other test modes.

The 'Press To Talk' switch on the accessory microphone, if this accessory is fitted, will switch the instrument from Rx TEST mode to Tx TEST mode. Therefore line 0 will also change state when the 'Press To Talk' switch is operated.

When the 'Line 1 Mode' is set to 'Close on Squelch', line 1 will take up the 'Closed/Logic High' state when the instrument is in a squelched condition, and the 'Open/Logic Low' state when the instrument is not squelched.

LOCAL OPERATION

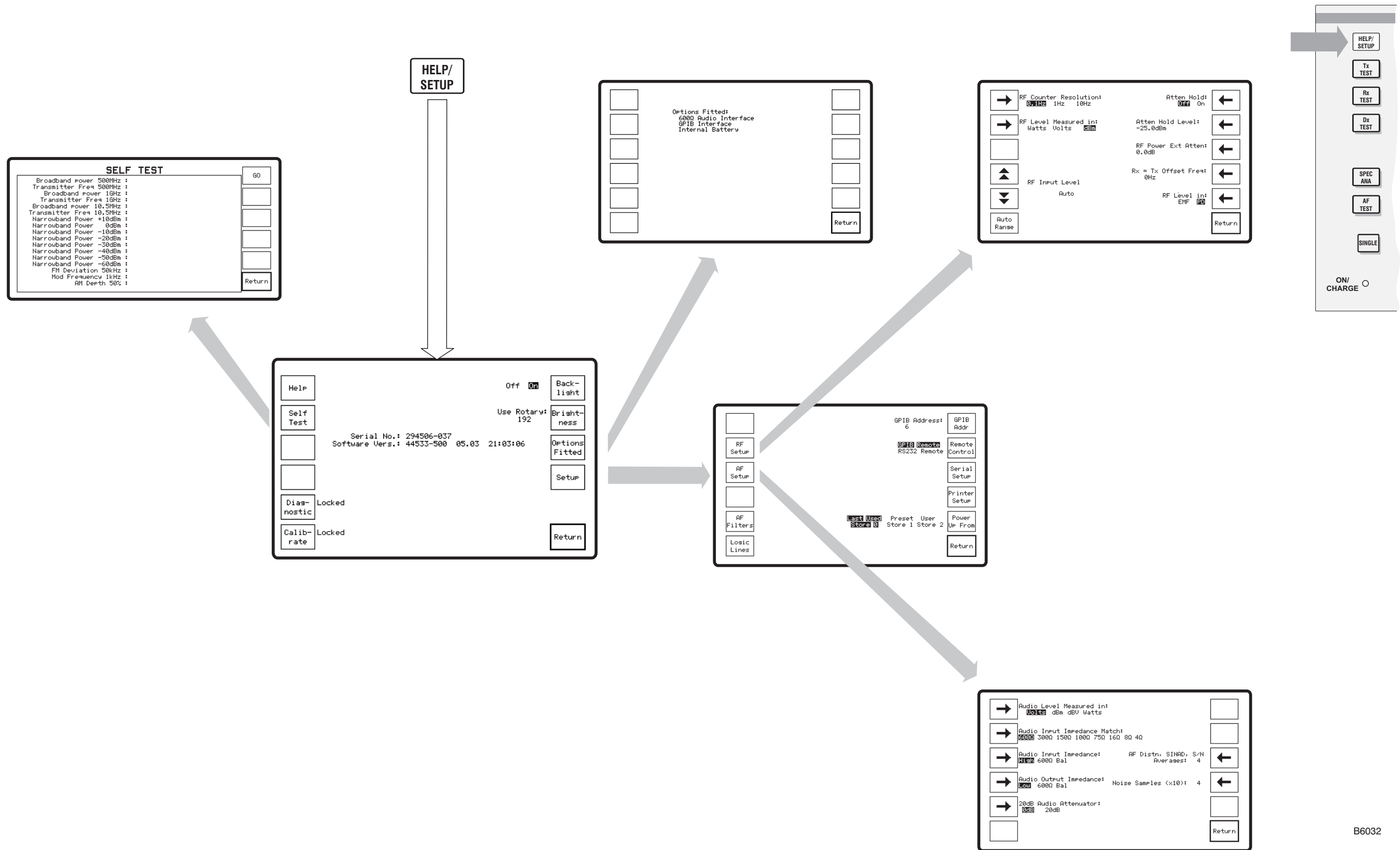

Test mode screen and menu (1.0). HELP/SETUP with lower levels.

B6032



LOCAL OPERATION

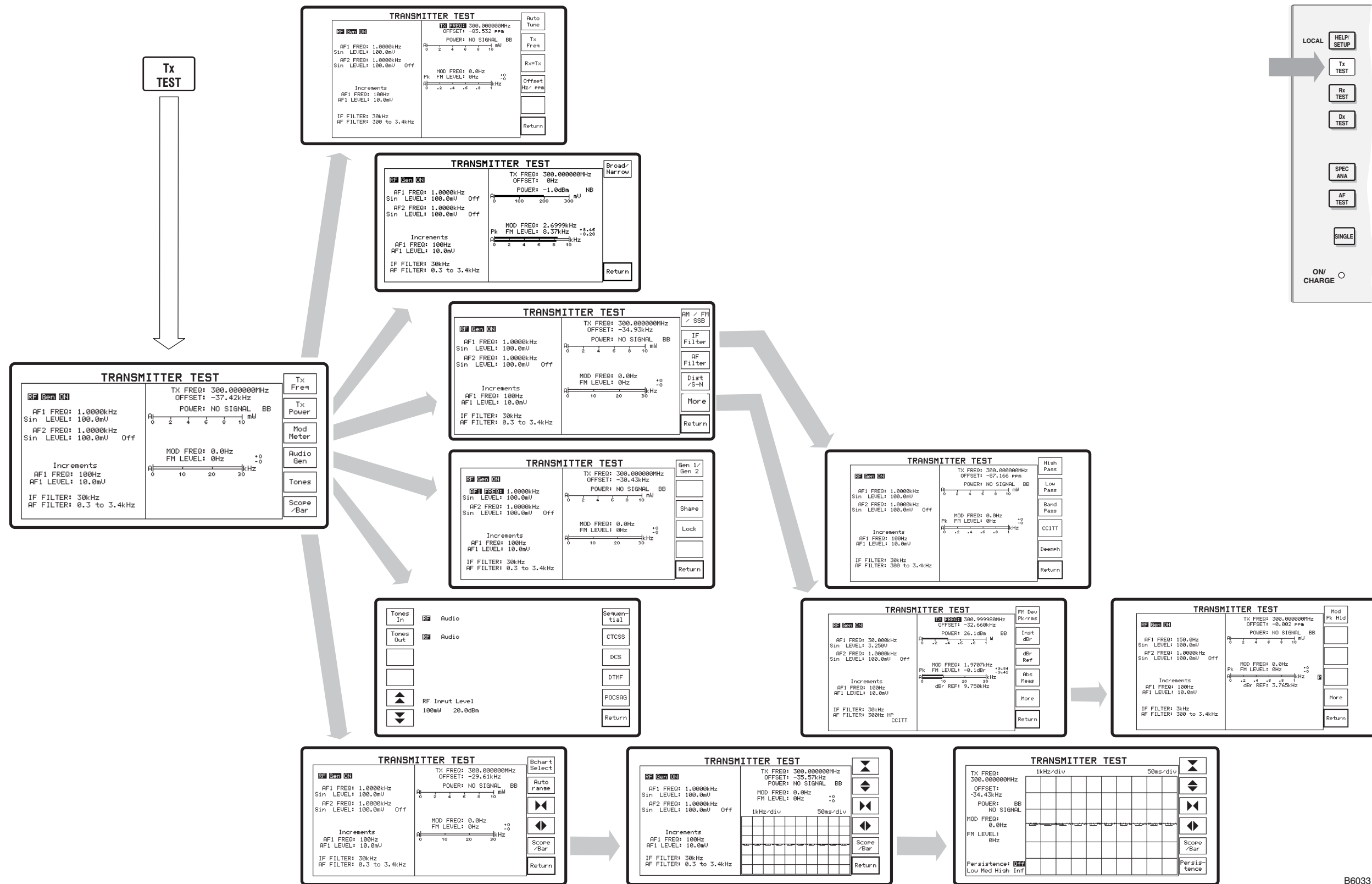

Test mode screen and menu (2.0). Tx TEST with next levels.

LOCAL OPERATION

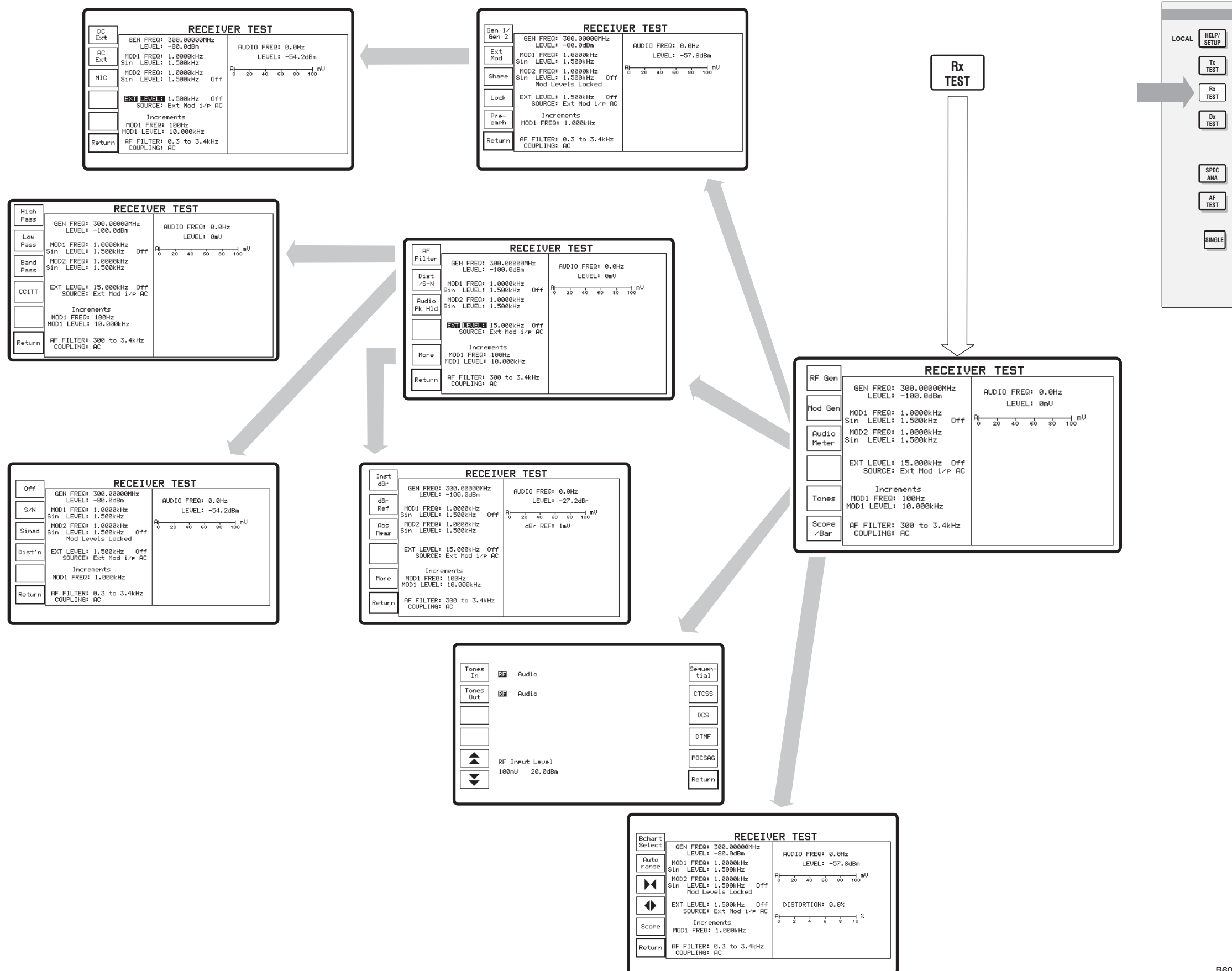

Test mode screen and menu (3.0). Rx TEST with next levels.

B6034

# LOCAL OPERATION

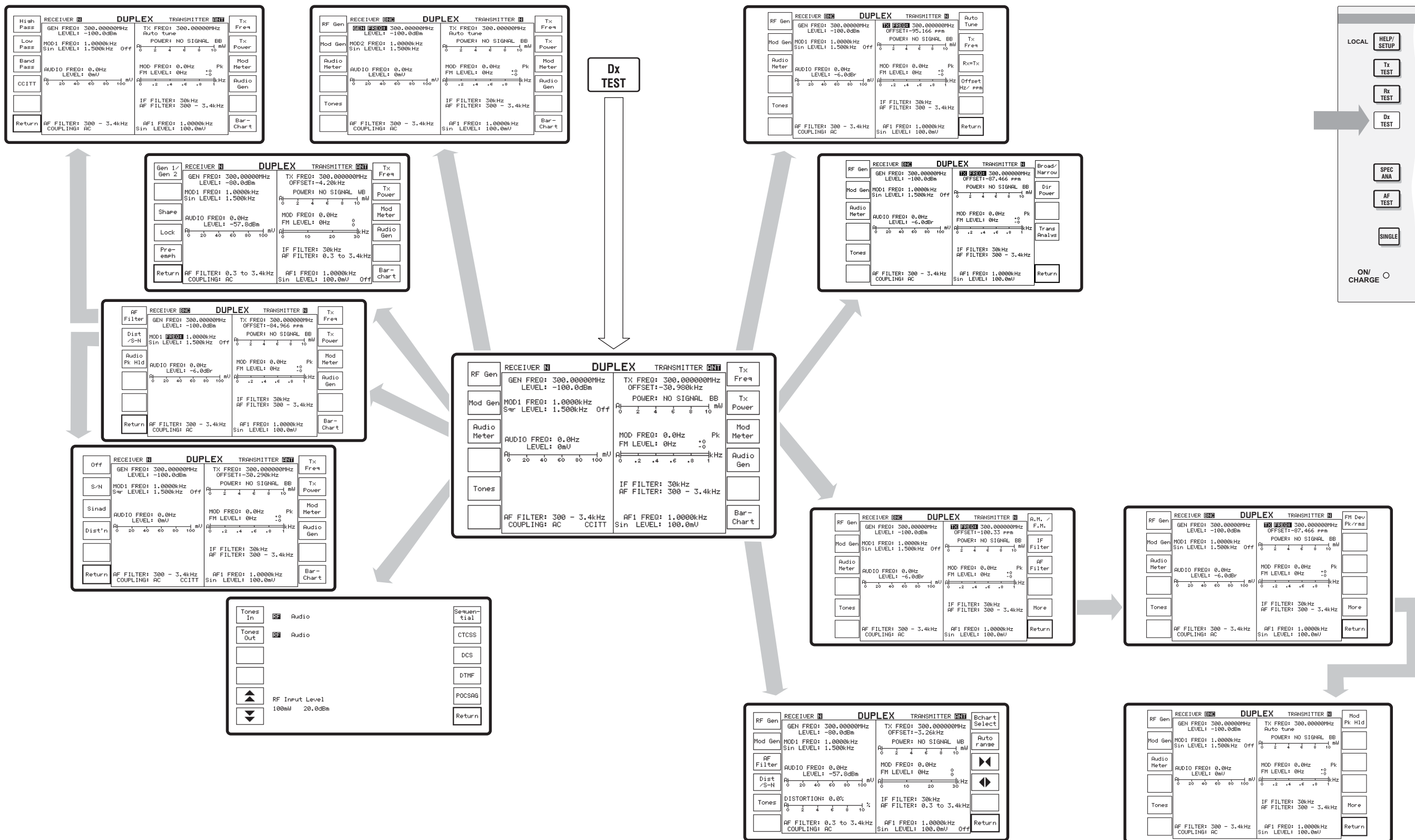

Test mode screen and menu (4.0). Dx TEST with next levels.

LOCAL OPERATION

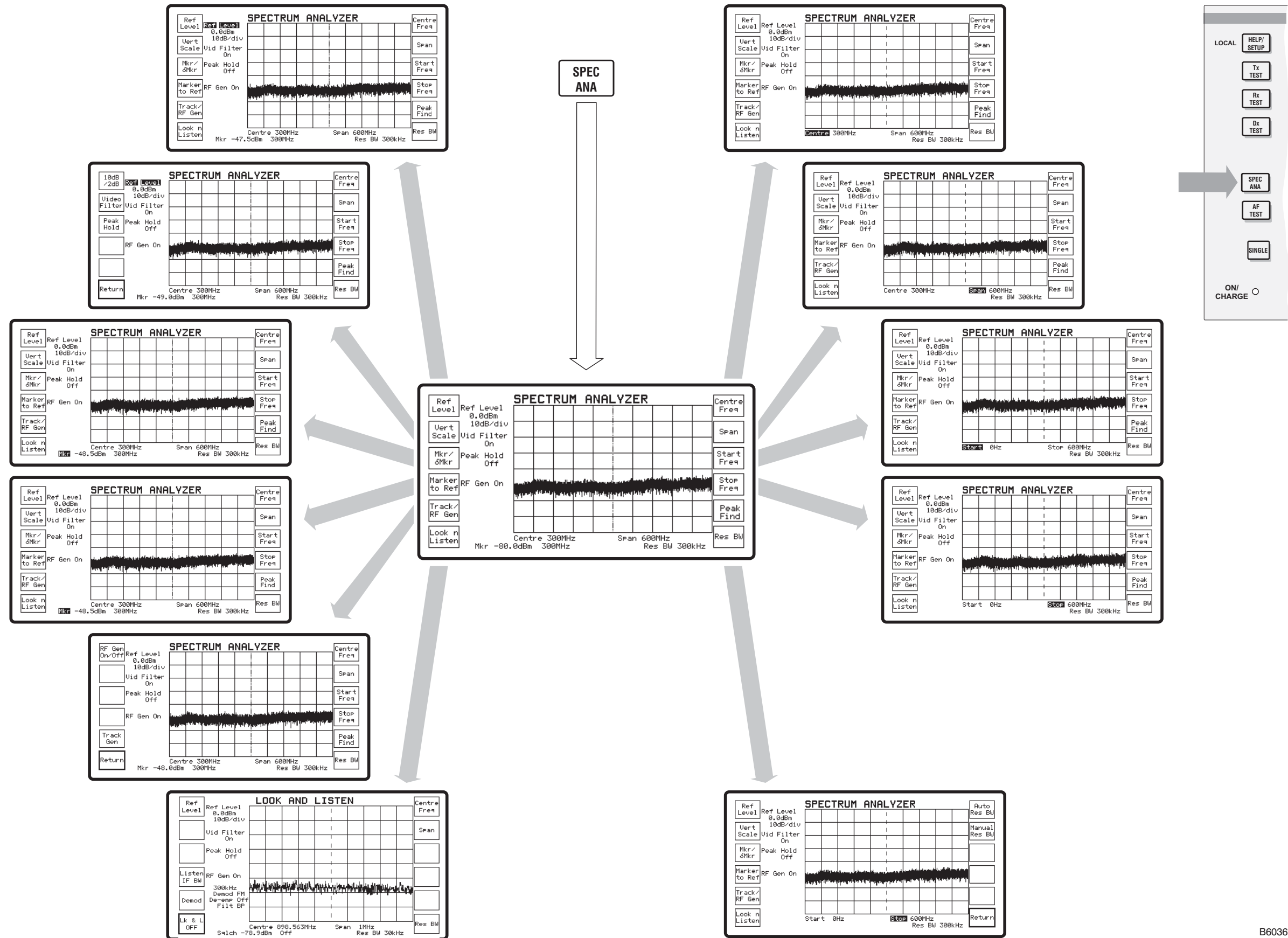

Test mode screen and menu (5.0). SPEC ANA with next levels.

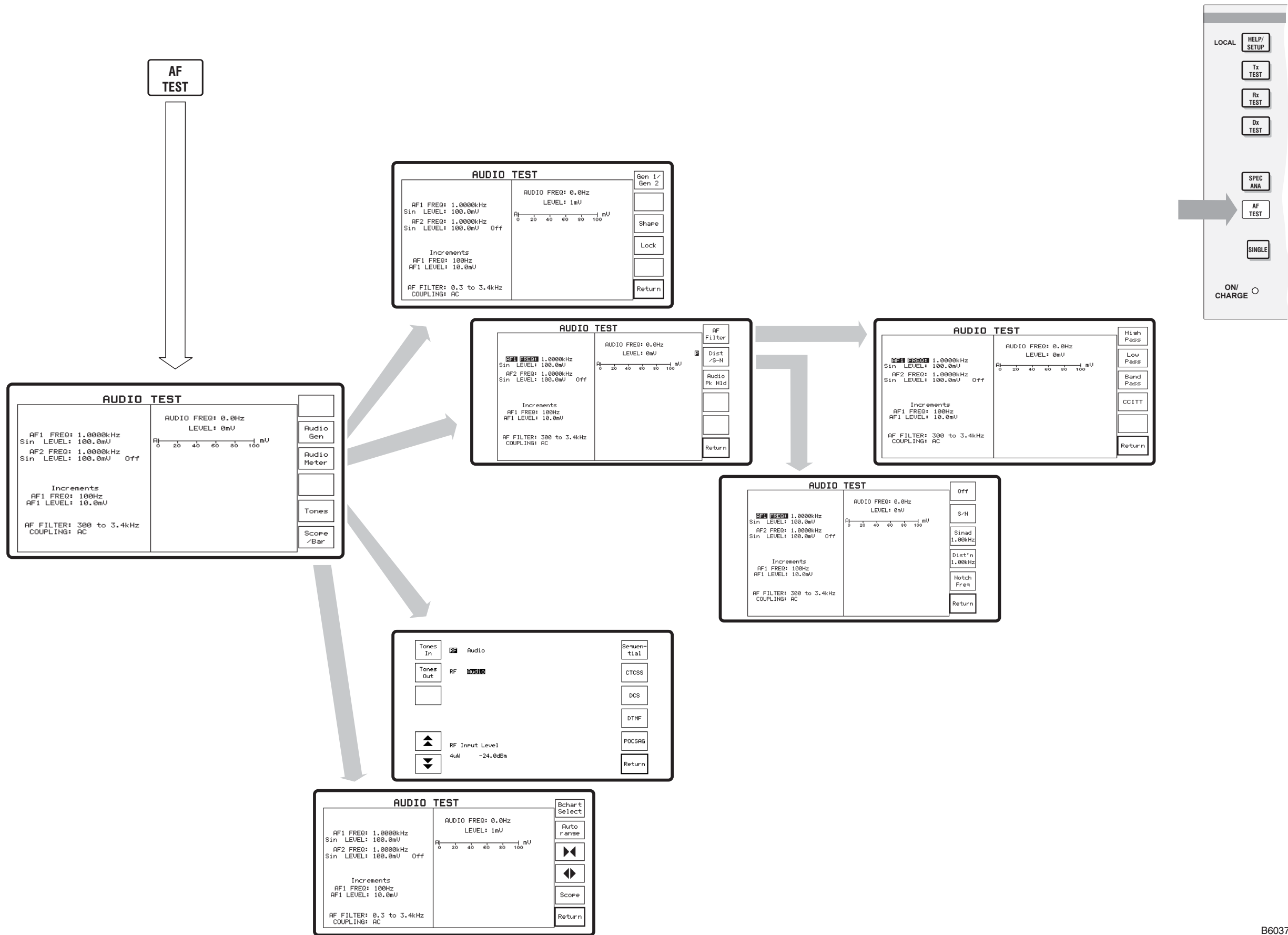

Test mode screen and menu (6.0). AF TEST with next levels.

---

# Chapter 4

## TECHNICAL DESCRIPTION

### Contents

Overview.....	4-2
Power supply .....	4-2
The display.....	4-3
Tx test mode.....	4-7
Modulation sources.....	4-7
Audio generators.....	4-7
Data generator.....	4-8
Receiver circuits .....	4-9
Input switching .....	4-9
Broad band power meter.....	4-9
Overload detection.....	4-10
Switched attenuator .....	4-10
IF circuits.....	4-10
First frequency changer/mixer .....	4-10
First local oscillator .....	4-10
Second frequency changer/mixer .....	4-10
Second local oscillator.....	4-11
Third frequency changer/mixer .....	4-11
Bandwidth filters .....	4-11
Demodulators.....	4-11
AM demodulator.....	4-11
FM demodulator .....	4-11
SSB demodulator (optional).....	4-12
De-emphasis filter.....	4-12
RF counter .....	4-12
Measurement ranging circuits.....	4-12
Distortion/SINAD filter .....	4-13
Oscilloscope function .....	4-13
Rx test mode .....	4-13
RF generator .....	4-13
Modulators.....	4-14
RF amplifier.....	4-14
Audio generators.....	4-14
Modulation control .....	4-14
Pre-emphasis filter .....	4-14
AF measuring circuits.....	4-14
Oscilloscope function .....	4-15
Dx test mode .....	4-15
Spectrum analyzer mode.....	4-15
Look and listen function (optional) .....	4-15
AF test mode.....	4-15

### List of figures

Fig. 4-1 Block diagram of power supply module .....	4-2
Fig. 4-2 Simplified block diagram .....	4-5
Fig. 4-3 AF generator detailed block diagram .....	4-7
Fig. 4-4 Input switching and broad band power meter block diagram .....	4-9

## Overview

This simple description is provided to give the user an insight into the working of the Service Monitor at the block diagram level. See Fig. 4-2 Simplified block diagram.

The power supply and display unit are described first. The functional circuit blocks of each test mode are then described in sequence.

The Service Monitor is of modular construction, comprising a number of printed circuit boards, (at least 15, depending on options included). These are housed in two sub-assemblies, along with input and output attenuators, power supply, front panel, rear panel and display unit modules. The Service Monitor is microprocessor controlled and software driven.

## Power supply

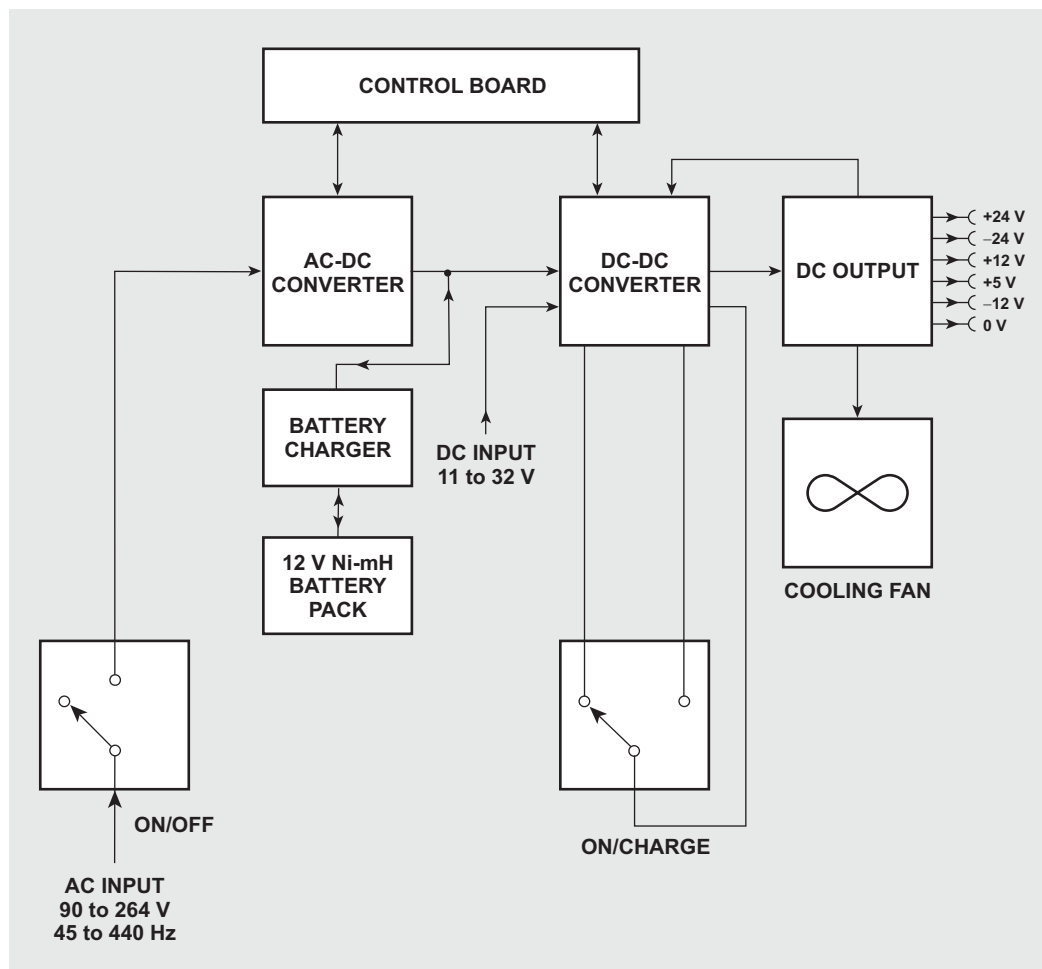

C6038

Fig. 4-1 Block diagram of power supply module

The power supply module is a switched mode design which will operate from an AC supply of 90 to 265 V, 45 Hz to 440 Hz or a DC supply of 11 to 32 V.

The circuits of the instrument require supplies of:

+5 V	3.0 A
+12 V	2.5 A
-12 V	1.2 A
36 V	100 mA output

The AC supply enters the instrument through a connector on the rear panel and passes through a fuse and supply on/off switch. The supply then enters the power supply module where it is fed to a bridge rectifier in the AC-DC converter to produce an unregulated DC supply. The voltage of this will depend on the supply voltage as the full range of AC input voltage is covered without range switching.

The second stage of the AC-DC converter produces semi-regulated DC supplies of 12 V or 24 V using a 60 kHz switched mode oscillator and transformer coupling. This transformer also provides the safety isolation barrier.

The DC external or the DC supply from the AC-DC converter is used to drive the DC-DC converter.

The DC output circuits producing the four output supplies are each fed from an individual winding on the DC-DC converter output transformer.

Regulation is applied to the DC-DC converter from the output current and voltage sensing circuits.

Current monitoring to provide regulation is obtained from the three common-return supplies and voltage monitoring from the +5 V supply.

The 36 V is generated by adding a 24 V floating supply onto the +12 V supply rail.

The floating 24 V supply has a voltage regulator configured within it.

A control circuit PCB contains the components for frequency control and regulation of both converters.

The on/charge switch routes the output from the power supply to either power the instrument or charge the battery.

### **The display**

The display device is a color transfective TFT liquid crystal display module with an active viewing area 143 mm x 80 mm. It comprises the display module, a driver board, and a cold cathode fluorescent tube (CCFT) backlight.

The viewing area is composed of a 1200 X 240 RGB dot matrix. Each pixel is sequentially addressed with a 6-bit data bus to determine its color and intensity. The display contrast is fixed, but the brightness can be adjusted over a small range by varying the backlight drive. This is achieved by generating a programmable voltage on the microprocessor board and feeding it to the backlight inverter, mounted on the rear of the display module. The inverter produces approximately 1500 V for the CCFT backlight. In high ambient light conditions the backlight can be switched off to conserve battery power.



TECHNICAL DESCRIPTION

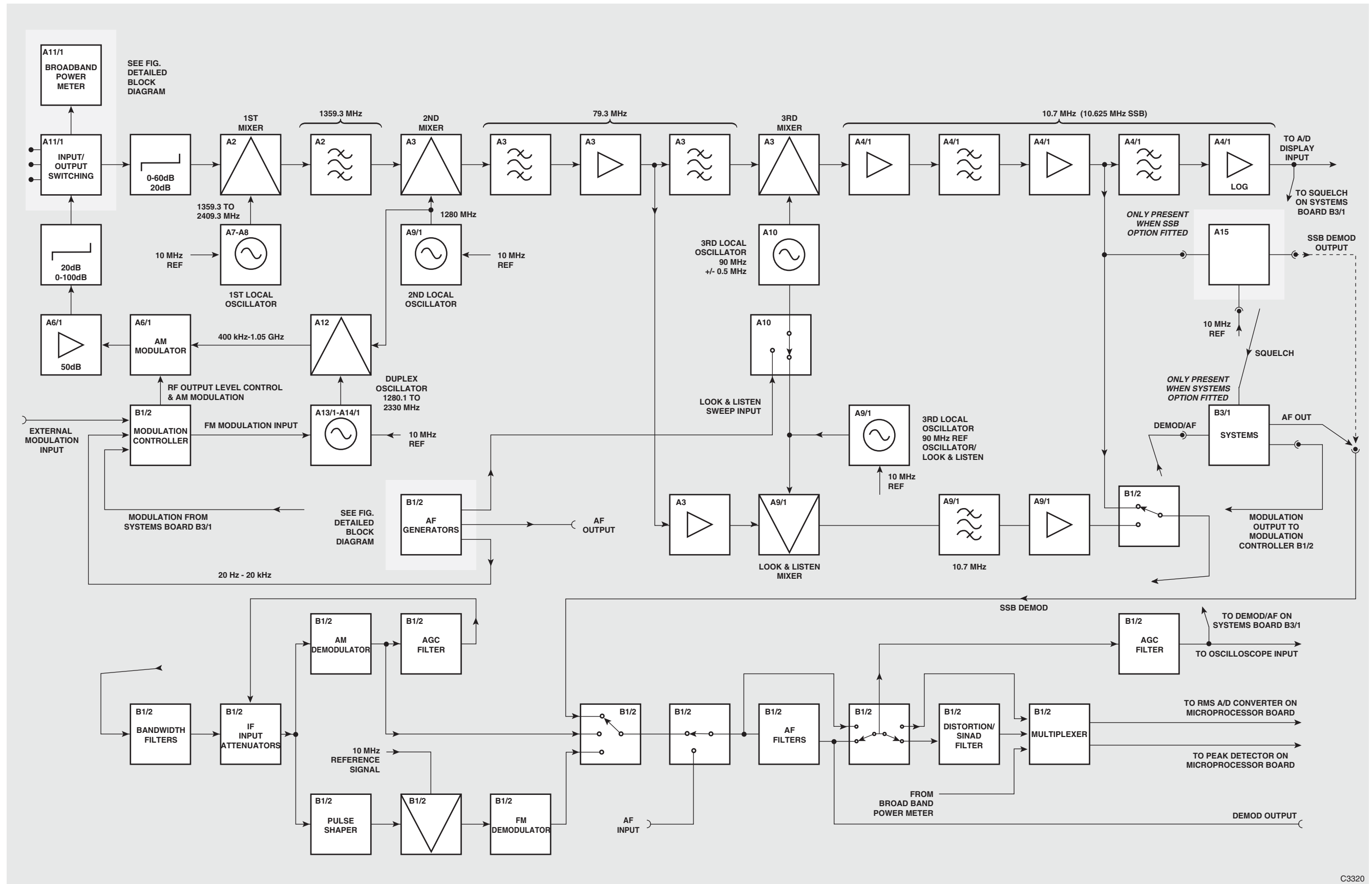

Fig. 4-2 Simplified block diagram

## Tx test mode

When operating in the Tx TEST mode the Service Monitor has to provide a source of modulation for the transmitter being tested and also analyze the RF output signal from the transmitter.

### Modulation sources

The modulating signal is provided by one or both of the audio generators or the data generator and is taken from the AF output connector on the front panel.

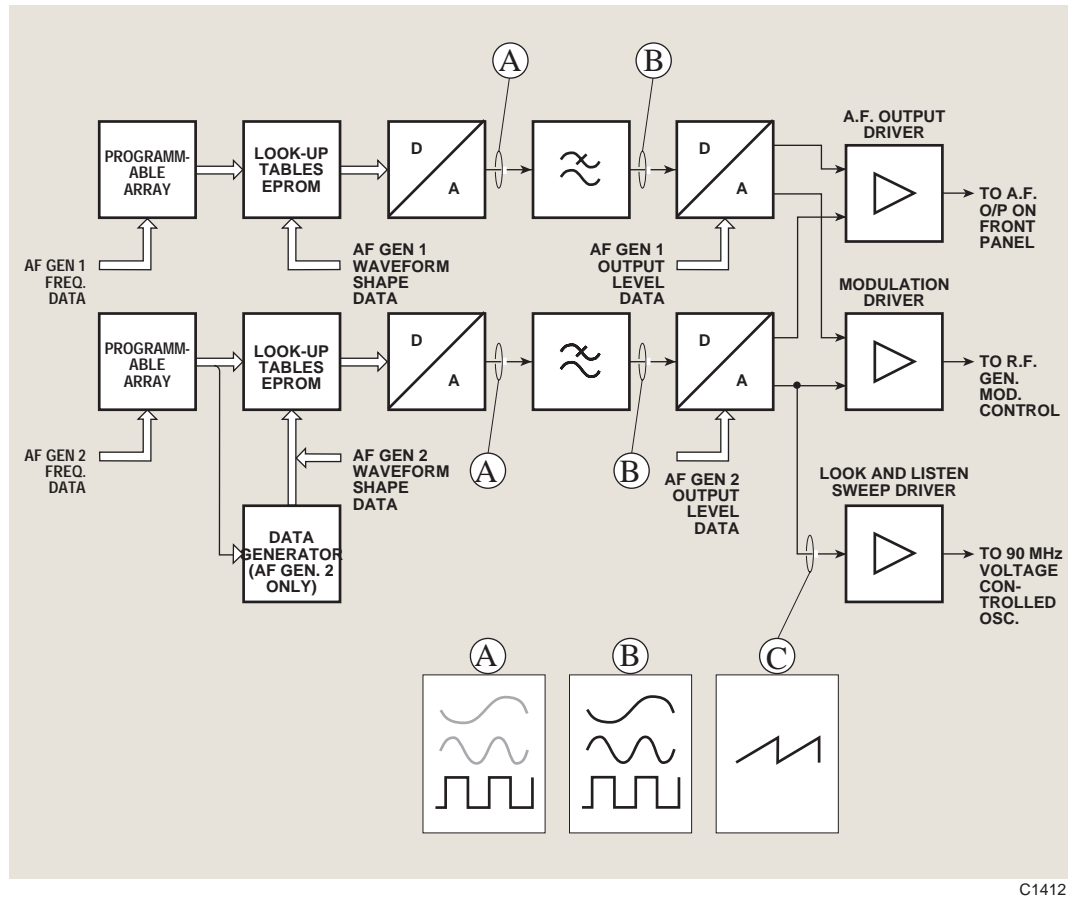

C1412

Fig. 4-3 AF generator detailed block diagram

### Audio generators

Included in the monitor are two audio generators, shown as 'AF generators' on the simplified block diagram. They are used as modulation sources for the Tx, Rx and Dx TEST modes and as audio test signal generators in the AF TEST mode. Fig. 4-3 is a detailed block diagram of the AF generators. They have a frequency range of 20 Hz to 20 kHz. The output waveform of either generator can be switched between sine wave or square wave. Both generators are of similar design, with minor variations. The generator designated 'GEN 2' is also used for other functions which do not conflict with its functions as an audio generator. These uses will be mentioned where relevant.

Each of the circuits function in the following manner:

Instruction as to the frequency of the required signal is latched into a programmable array device, which generates a repetitive digital output sequence recurring at the required frequency. The digital output from the programmable array is transferred as a stream of 13 bit parallel data into an EPROM. This holds look-up tables containing shape details of sine wave and square wave signals. Output from the EPROM is as 8 bit parallel information corresponding to the selected shape and at the repetition frequency instructed by the information latched into the programmable array device.

The EPROM output is applied to a digital to analogue converter which, by converting each digital value to the corresponding analogue level, produces the required signal. The mean output level from the digital to analogue converter is constant. The analogue output is filtered by a 50 kHz low-pass active filter, to remove any spikes created by the digital generation process. The output from the filter has a peak to peak level of 5.7 V.

Output level is controlled by a digital to analogue converter, configured as a digital level control circuit. The constant level AF signal is applied to the reference voltage level input, while the digital input register is supplied with the data relating to the level of output signal required. The output from the digital to analogue converter will be a replica of the signal at the reference voltage terminal but proportionally reduced, relative to the data values at the digital input terminals.

After buffering, the AF generator outputs are switched to the AF output drivers for impedance matching, prior to routing to the AF OUTPUT connector on the front panel. The output level available at the AF output connector is infinitely variable from 0.1 mV to 4.0 V RMS.

**Note:** The AF generators are also used as modulation sources for receiver testing. Therefore the options available to the user when carrying out duplex tests are :-

Both generators to modulate the transmitter under test, receiver test signal not modulated.

Both generators to modulate the receiver test signal, transmitter under test not modulated.

One generator to modulate the transmitter under test and one to modulate the receiver test signal.

### Data generator

The data generator is a 'D type' flip-flop, used to control AF generator 2 when pulsed tones are required as modulation, such as for Digitally Coded Squelch applications. The Q1 output of the data generator IC is used as the A13 address line on the lookup table EPROM. The data generator will thereby directly switch this line, which is arranged to cause full output or no output. The result is that data applied to the flip-flop D2 input, will appear as tone pulses at the output of AF generator 2.

When not required to produce data, the data generator is configured as a transparent flip-flop, with the A13 address line functioning normally.

Receiver circuits  
Input switching

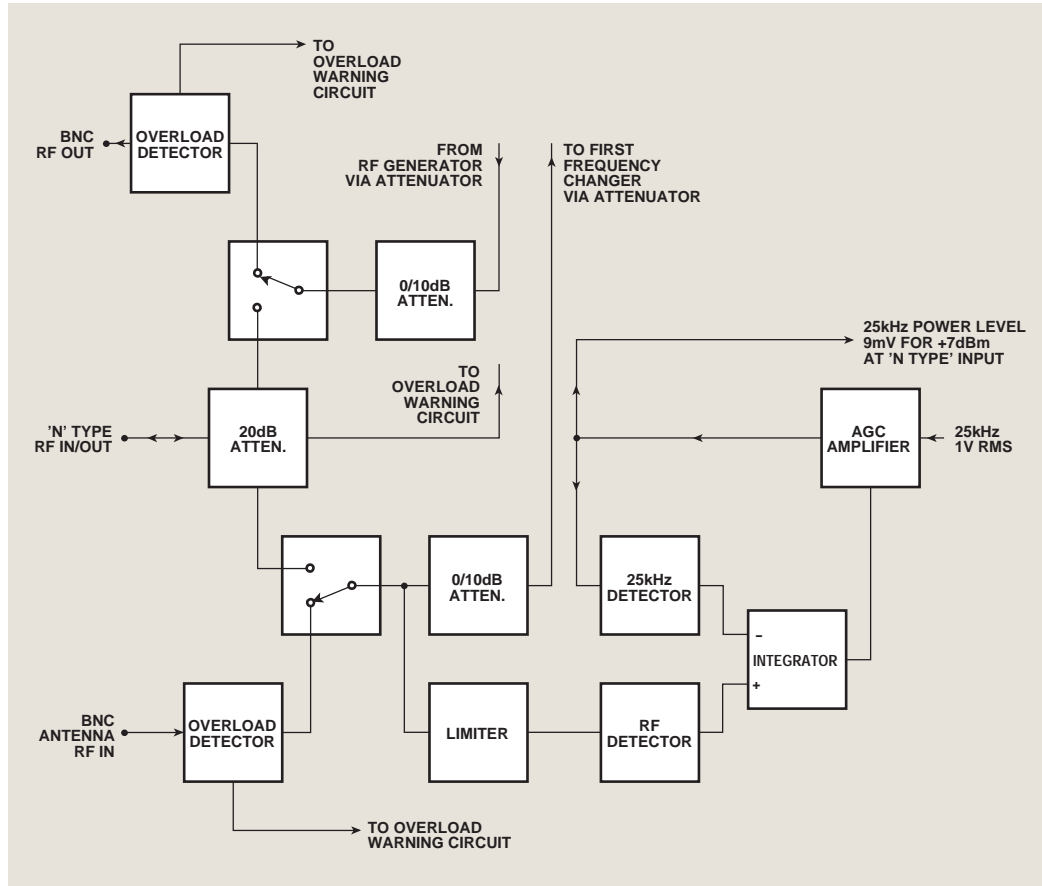

C1411

Fig. 4-4 Input switching and broad band power meter block diagram

The RF signal from the transmitter enters the monitor at either the BNC antenna input or the 'N Type' connector on the input/output switching board. A detailed block diagram of the input switching board is shown in Fig. 4-4 *Input switching and broad band power meter block diagram*.

The 'N type' connector, which is also used as an output for receiver testing, has a 20 dB power attenuator, 20 dB between it and the input/output switching circuits.

The RF signal, from the transmitter under test, can be within the frequency range of 100 kHz to 1.05 GHz. A 10 dB attenuator pad can be switched into the transmitter test RF path by the instrument software.

**Broad band power meter**

A proportion of the signal is fed directly to the broad band power meter circuits. The RF signal is passed through a diode detector and the resultant DC signal integrated with a similar signal derived from a 25 kHz signal from board B2. As the integration is carried out using the inverting and non-inverting inputs of an operational amplifier, a stable condition will result when the two inputs are of the same value.

The output from the integrator is used as a control signal for an AGC amplifier acting on the 25 kHz signal, with the output from the AGC amplifier supplying the integrator. The loop will therefore remain stable with the AGC amplifier output voltage exactly equaling the voltage of the RF input to the detector. This voltage is taken to the voltmeter ranging circuits on the AF Analyzer Board B1 and then to the AF voltmeter circuit on the microprocessor board.

### Overload detection

An overload detection circuit is activated if power in excess of 1.0 W is applied to the BNC antenna connector or to the BNC RF output connector. The overload detect lines are activated and trigger the overload warning message from the microprocessor. A temperature sensor, in physical contact with the 20 dB pad on the 'N type' connector, triggers the overload circuit in the event of excessive power being applied to that connector for a period long enough to cause an excessive temperature rise

### Switched attenuator

A switched attenuator with one 40 dB pad, one 20 dB pad or 0 dB attenuation, selectable in any combination and controlled by the instrument software, is situated between the input switching board A11/1 and the first frequency changer/mixer board A2.

## IF circuits

### First frequency changer/mixer

The RF signal from the switched attenuator, enters the first frequency changer/mixer board A2 and passes through an overload prevention circuit, which limits any input signal to approximately 0.7V peak. The signal then passes either directly, or through a 20 dB amplifier, to the 1st mixer.

### First local oscillator

The mixer is also supplied with a signal from the first local oscillator board A8/1. This oscillator is a fractional 'N' controlled oscillator, which can be made to run at any frequency between 1.36 and 2.36 GHz, in increments of 1 Hz. The actual frequency is determined by the control system of the monitor. If the transmitter test frequency is known and has been entered into the monitor as a 'Tx FREQ' using the data input keys, the oscillator will be made to run at a frequency 1.3593 GHz above this value.

By mixing this signal with that from the input circuits, the output from the mixer will contain a signal of 1.3593 GHz.

Where the required frequency of the monitor receiver circuits is to be established by the 'Auto Tune' function, the variable oscillator is made to sweep through its operating range by the instrument's software. When a signal is detected at the demodulators, the sweep rate is slowed and locked.

Filtering in the mixer output removes the upper frequency components of the mixing process.

### Second frequency changer/mixer

The signal from the first mixer is further reduced in frequency by a second frequency changing mixer which has an output of 79.3 MHz. This is on the second and third mixer board A3. The signal arriving at board A3 is first passed through a 1.3593 GHz band-pass filter and is then applied to the input of the second mixer.

### Second local oscillator

The local oscillator signal for the second mixer has a frequency of 1.280 GHz and is generated on the second and third oscillator board A9/1. This oscillator is a phase locked loop device, locked to the instrument's 10 MHz reference oscillator.

The output from the second mixer is passed through a 79.3 MHz band-pass filter, to remove the unwanted products of the mixing process, before being given 20 dB amplification.

The 79.3 MHz IF signal is split and fed to two independent mixers.

The secondary feed supplies the 90 MHz swept local oscillator board A10. This operates as a swept oscillator when the spectrum analyzer Look and Listen function, is active, as described later. It provides a locked 90 MHz signal for the third mixer at other times.

The primary path is through a band-pass filter with 5 MHz bandwidth, to the main 90 MHz 3rd mixer. This mixer is on the second and third mixer board A3.

### Third frequency changer/mixer

A third frequency change is made to the signal to achieve a final IF of 10.7 MHz.

The local oscillator signal for the third mixer is provided by the voltage controlled oscillator on A10. This oscillator runs at 90 MHz and for normal transmitter testing is locked to the output of a 90 MHz reference oscillator on the second and third oscillator board A9/1.

### Bandwidth filters

The 10.7 MHz output from the third mixer in the Tx TEST path, passes from the second and third mixer board A3 to the 10.7 MHz IF and Log amplifier board A4/1.

Filters on this board provides the bandwidth filtering for the signal path in the Tx TEST mode and also for the SPEC ANA mode. The bandwidths provided are 3 MHz, 300 kHz, 30 kHz, 3 kHz and 300 Hz, using crystal filters controlled by signals from the micro processor.

A direct, un-filtered path is also provided.

After filtering, the signal is passed to the demodulators on the audio processor board B1/2.

## Demodulators

### AM demodulator

The demodulators are located on the audio processor board B1/2. The IF signal from the IF and Log amplifier board A4/1, is fed to a phase splitter circuit which provides anti-phase outputs for the AM demodulator. The outputs from the phase splitter are taken to the positive and negative inputs of the balanced demodulator. The demodulator is also fed with balanced unmodulated inputs, obtained from the modulated 10.7 MHz signal, by way of a phase-splitting limiter.

The demodulator produces a balanced output equal to the difference between the two input signals. This will have an AF component equaling the modulation signal and a DC component relating to the level of the IF signal. The modulation is fed to the AF switching circuits while the DC component is used for automatic gain control.

### FM demodulator

FM demodulation is performed by a pulse width discriminator operating at 700 kHz. The signal for this is obtained by mixing the 10.7 MHz output from the limited signal fed to the AM demodulator, with the 10.0 MHz reference frequency and passing the resultant signal through a low-pass filter.

The 700 kHz signal containing the FM information is fed into a both halves of a dual monostable flip-flop. By putting this signal to A1 and B2 inputs, the Q-outputs from the monostables will be in anti-phase. By summing the two output signals the resultant signal will be a true representation of the modulation.

### SSB demodulator (optional)

The single sideband demodulator circuits are all contained on the SSB demodulator board A15.

When the SSB demodulation function is selected the first local oscillator of the Service Monitor is set to a frequency which will produce a final IF of 10.625 MHz (from an input frequency equal to the carrier frequency) rather than the 10.7 MHz IF produced for all other modes. The IF signal for the SSB board is obtained from the third mixer on A3, through a 10.7 MHz low-pass filter on A4/1.

It is applied to a variable gain circuit which is used to control the input level for the SSB demodulator circuits.

After leaving the gain control circuit the signal is then mixed in a double balanced mixer with a 10 MHz signal from the instrument reference oscillator. The output from the mixer will contain a 625 kHz component. This is passed through a 625 kHz low pass filter, to one input of another double balanced mixer. The second input is fed with a reference signal of 625 kHz derived from the 10 MHz reference through a 'divide by 16' circuit. The output from the double balanced mixer will be zero when no modulation is present on the input signal. When modulation is applied, the output signal will equal the difference in frequency between the original carrier frequency and the original sideband frequency. Either an upper sideband signal or lower sideband signal will produce an output. This will equal the frequency of the applied modulation. The demodulated signal is fed to the input of the audio routing circuits.

### De-emphasis filter

The output from the discriminator passes through a 163 kHz low-pass filter and then the 750  $\mu$ s de-emphasis filter before being routed by the demodulation selection switches. The de-emphasis filter can be by-passed as part of the test set-up.

### RF counter

A sample of the 10.7 MHz IF signal is taken from one output of the phase splitter/limiter and supplied to the IF counter circuit, also located on B1/2.

This counter measures the mean frequency of the IF signal and the result is written into memory. By making a calculation using the reading from the RF counter and the division ratios from the three local oscillator control loops, the instrument software can establish the mean frequency of the transmitter output.

### Measurement ranging circuits

The evaluation of RF level, modulation depth, modulation deviation, distorted levels etc. are all made using a metering circuit on the microprocessor board B2/1. Before the various levels can be measured, each must be conditioned so as to bring the minimum and maximum levels of each parameter within the range of the metering circuit. The signals to be measured are all brought to the analyzer ranging circuits on the audio processor board B1/2. Signals relating to RF power input to the instrument and power readings from an auxiliary power head are passed through various switched gain amplifiers before leaving the board to be measured.

Measurements to the demodulated AF signals are made after filtering to the selected AF filter pass band. The AF filters are located on the audio processor board and offer the choice of 300 Hz-3.4 kHz band-pass; 15 kHz low-pass; 300 Hz low-pass and the full bandwidth of 50 kHz.

The selected filters are switched into the AF circuit before the ranging amplifiers.

### **Distortion/SINAD filter**

The 1.0 kHz active notch filter, used to make distortion percentage and SINAD measurements, is also on the audio processor board B1/2. This filter is switched into circuit to make comparison measurements against the unfiltered path.

The additional distortion frequencies enabled by Option 29 are provided by an additional board that plugs into the audio processor board B1/2. It provides two additional notch filters and the necessary circuits to switch between them.

Each filter is very similar to the standard 1 kHz filter but with different component values required for the different notch frequencies.

### **Oscilloscope function**

The oscilloscope function when used within the Tx TEST mode displays the waveform of the demodulated signal. The signal for this is taken from the AF filter output and after passing through level converting amplifier circuits is fed to an analogue to digital converter located on the microprocessor board B2/1. The digital levels relating to the waveform are written into a digital signal processor which generates the oscilloscope display. The values are incorporated into the display and updated continually.

### **Rx test mode**

The Rx TEST mode uses the signal from the RF signal generator circuits, as an input signal for the receiver under test. The AF signal, produced by the demodulator within the receiver, is analyzed within the Service Monitor to produce results of the test.

Selecting the Rx TEST mode does not disable the functions of the Tx TEST mode. The receiver circuits remain active at their last settings. The AF generators will also continue operating at their last settings unless either is enabled as a modulation generator. Calling up one modulation generator will allow the other to function as an AF generator for the Tx TEST mode, but using both as modulation sources will remove both from Tx TEST use.

### **RF generator**

The RF signal is produced within the monitor by a fractional N controlled oscillator with a range of 1,280.1 MHz to 2,280.0 MHz. This is located on the RF generator oscillator board A13/1. The oscillator and its control system are of a complex design in order to meet strict requirements of frequency stability, low phase noise and very fast settling after a change of frequency. The output from this oscillator is fed to the RF generator mixer board A12/1, where it is combined with a signal taken from the output of the second local oscillator on A9/1.

The mixer output is filtered by a 1050 MHz low-pass filter to remove all unwanted frequencies, before passing to the RF output amplifier board and AM modulator board A6/1.



### Modulators

The Rx TEST signal can be either AM or FM modulated.

The selected modulation signal, from either or both of the AF generators, from the data generator or from an external source, is conditioned and level corrected within the modulation control circuits on the audio processor board B1/2.

Frequency modulation is applied by injection into the fractional N control loop, thereby influencing the generated frequency. When the signal is FM modulated, the AM modulator is held in a 0% modulation state.

AM modulation is applied to the signal using a pin diode modulator, located within the output amplifier circuits on A6. The output level of the Rx TEST signal is also controlled using the pin diode modulator.

The signal controlling the attenuation level of the pin diode modulator, is a composite signal containing the amplitude modulation component obtained from the modulation source and a DC component representing the required output level.

They are combined into one modulation signal using a digital to analogue converter on the audio processor board B1/2

### RF amplifier

The signal level from the AM modulator is increased by 50 dB by a three stage RF amplifier before passing through the output control attenuator to the RF switching unit and the RF output sockets.

### Audio generators

The audio generators on the B1/2 are used to provide AF Modulation to the RF test signal generated on the RF generator oscillator board A13/1. The operation of the generators is as described for the Tx TEST mode but rather than the output level being called up as an output voltage, this is specified as a modulation level. The necessary calculations are performed by the instrument software.

The DATA GENERATOR facility is available in the Rx TEST mode.

### Modulation control

The output from each generator is taken through selector switches to a summing amplifier at the input to the modulation control circuits. The signal from an external modulation source or from the modulation options circuits is also summed in at this point. An external modulation source can be connected to the EXTERNAL MOD IN connector on the rear panel and is passed through a level control circuit of the same type as that in the AF generator circuit, incorporating a digital to analogue converter, with the signal input to the voltage reference point and the level set by the value on the digital input.

The summed modulation signal is taken through a modulation correction level control circuit before being routed to either the FM attenuator digital to analogue converter or to the RF level digital to analogue converter. This device provides fine level control of the RF signal by applying a DC level to the AM modulator as described earlier.

### Pre-emphasis filter

A 750  $\mu$ s pre-emphasis filter is included on the audio processor board and is switched into the FM modulation path when selected as part of the Rx TEST set-up.

### AF measuring circuits

The AF output signal from the receiver under test is fed into the AF INPUT connector of the Service Monitor. This signal is directly fed to the audio processor board and applied to a switched divide by 2/divide by 20 circuit. It is then routed through two paths, one to the AF filtering and measuring path, the other to the oscilloscope input circuits.

## Oscilloscope function

When used in the Rx TEST mode, the oscilloscope displays the AF input signal fed to the AF input connector.. The signal is passed through a sensitivity control circuit for scope calibration before following the same path as used in the Tx TEST mode.

## Dx test mode

The Dx TEST mode uses all the circuit elements described in the proceeding sections. The technical description is valid for all three modes. The display presentation allows parameters applicable to transmitter testing and receiver testing to be seen simultaneously.

## Spectrum analyzer mode

Data to be presented as the active trace on the spectrum analyzer display is obtained through the following circuits:-

The input frequency of the Service Monitor is made to sweep through the frequency range selected on the display by sweeping the first local oscillator, located on A7/1. Any signals which fall within the sweep range will pass through the IF circuits of the Service Monitor.

The output from the third mixer is amplified and filtered on A4/1, then fed to a logarithmic amplifier. The 10.7 MHz signal is detected to produce a DC signal, the level of which is relative to the level of the RF signal input. The DC voltage is digitized by an analogue to digital converter on the Microprocessor board B2/1. The digital value obtained is stored in RAM at a memory location which is related to the sweep position and to the value.

Each time the display is refreshed, the contents of each display location address will provide the latest data, thus updating the display. The refresh rate is approx. 11 per second.

## Look and listen function (optional)

When the look and listen function of spectrum analyzer mode is selected, the operation is modified. In order to demodulate the center frequency of the span, the signal fed to the demodulator must be obtained from a fixed frequency point. As the frequency span in the look and listen function is limited to 2 MHz, the frequency sweep can be applied at the third mixer stage. A ramp voltage is generated within AF generator 2 on the AF board B1/2 and applied to the 90 MHz voltage controlled oscillator on A10. The 10.7 MHz IF signal will thus have swept over the selected range to produce a Frequency vs Signal Level display.

The signal fed to the modulator meter is obtained from the Look and Listen third mixer, located on the second and third local oscillator board A9/1. The demodulated AM or FM signal is amplified, to provide a low impedance output which is fed to the loudspeaker. It is also fed to the ACCESSORY connector on the front panel.

A 90 MHz reference oscillator on A9/1 provides the local oscillator signal for this mixer. It also provides a 90 MHz reference for the 90 MHz voltage controlled swept oscillator on A10.

## AF test mode

The AF TEST mode requires a signal source to apply to the circuit or equipment under test and a measuring facility to analyze the resultant output signal.

The signal source is provided by the audio generators as for the Tx TEST mode and the AF measuring circuits configured as for the Rx TEST mode. The RF generator and IF local oscillators are disabled. The power metering and modulation metering functions are also disabled.

---

## Chapter 5

# ACCEPTANCE TESTING

### Contents

Introduction.....	5-3
Results tables .....	5-3
Before starting .....	5-3
Test equipment.....	5-4
RF output tests .....	5-5
Carrier frequency accuracy.....	5-5
RF output level .....	5-7
ALC linearity .....	5-8
BNC output mode.....	5-8
Attenuator accuracy.....	5-8
Alternative attenuator functional check.....	5-9
Spectral purity.....	5-10
Harmonics, spurious, RF carrier leakage, residual FM. ....	5-10
Amplitude modulation .....	5-13
Frequency modulation .....	5-15
AF output tests .....	5-17
Audio generator output level .....	5-17
Audio generator distortion .....	5-18
Audio generator frequency .....	5-19
AF input tests .....	5-20
Audio frequency meter .....	5-20
Audio voltmeter .....	5-21
Audio oscilloscope.....	5-23
AF distortion & SINAD meter.....	5-24
RF input tests .....	5-25
Modulation analyzer - FM .....	5-25
Modulation analyzer - AM .....	5-28
RF frequency meter .....	5-30
RF spectrum analyzer .....	5-32
RF broad band power meter.....	5-34
<b>Acceptance Test Results Tables.....</b>	<b>5-36</b>

## List of figures

Fig. 5-1 Carrier frequency accuracy .....	5-5
Fig. 5-2 RF level set up.....	5-7
Fig. 5-3 Attenuator accuracy test set up.....	5-8
Fig. 5-4 Attenuator functional check .....	5-9
Fig. 5-5 Carrier harmonics & spurious check .....	5-10
Fig. 5-6 RF carrier leakage check .....	5-11
Fig. 5-7 Residual FM checks .....	5-12
Fig. 5-8 Internal AM accuracy checks .....	5-13
Fig. 5-9 Internal FM accuracy checks.....	5-15
Fig. 5-10 Audio generator level accuracy checks .....	5-17
Fig. 5-11 Audio generator signal purity checks .....	5-18
Fig. 5-12 Audio frequency meter check.....	5-20
Fig. 5-13 Audio voltmeter level accuracy checks .....	5-22
Fig. 5-14 Audio oscilloscope check.....	5-23
Fig. 5-15 Modulation meter FM .....	5-26
Fig. 5-16 Modulation analyzer — AM .....	5-28
Fig. 5-17 RF frequency meter .....	5-30
Fig. 5-18 RF spectrum analyzer checks .....	5-32
Fig. 5-19 RF broad band power meter checks .....	5-34

## Introduction

Test procedures described in this chapter may be simplified and of restricted range compared with those that relate to the generally more comprehensive factory test facilities which are necessary to demonstrate complete compliance with the specifications.

Performance limits quoted are for guidance and should not be taken as guaranteed performance specifications unless they are also quoted in the section *Performance data* in Chapter 1.

<b>Note</b>
-------------

**When making tests to verify that the instrument meets the stated performance limits, always allow for the uncertainty of the test equipment.**

## Results tables

A set of Results tables, each with a blank results column, is provided at the end of this chapter. It is suggested that these tables are copied, and the test results entered on the copies.

The Results table that is appropriate to each particular test or part of a test is referred to at the relevant point in the test procedure.

## Before starting

In line with best practice in electronic measurement, it is recommended that the Unit Under Test (UUT) is allowed to stabilize for thirty minutes after switch on to obtain optimum performance.

The key presses necessary to set UUT parameters may differ slightly from those stated in the text, depending on the version of software fitted.

To minimize the number of key presses that the user needs to make to obtain the correct instrument settings, each section assumes that the instrument is being configured from the instrument 'factory default power on state'. To ensure that this occurs, initially press the following keys: [HELP/SETUP], [*Setup*], [*Setup page 2*], toggle [*Power Up From*], until *Preset Store 1* is shown highlighted in inverse video. Each time the instrument is now powered up, it will enter its default power on state.

The instructions relating to test equipment operation assume that the test equipment used for each test is that suggested in the *Example* column of the following table (where there is more than one, the first item).

**ACCEPTANCE TESTING**

**Test equipment**

Description	Minimum specification	Example
Frequency counter	400 kHz to 1.05 GHz. 1 Hz resolution, external standard In/Out.	IFR* 2440 or EIP 25B
RF power meter	± 0.1 dB from 10 MHz to 1 GHz.	IFR* 6960/A/B + 6912 and 6920 sensor
Measuring receiver	-21 dBm to -127 dBm, 2.5 MHz to 1 GHz.	HP 8902A + 11772A sensor
Spectrum analyzer	400 kHz to 3 GHz, noise floor < -127 dBm.	IFR* 2383
50 Ω sealed load		
2-turn 25 mm loop		
Low-noise FM demodulator	Residual FM to be less than 2 Hz up to 1 GHz.	IFR* 2305 + IFR* 2041
Modulation meter	RF I/P 500 kHz to 1.05 GHz AM. Measurement accuracy up to 85% depth: ± 1% of reading at 1 kHz mod rate, ± 2.5% of reading for mod rates from 30 Hz to 50 kHz RF I/P 500 kHz to 1.05 GHz FM. Measurement accuracy ± 0.5% of reading ± 1 least significant changing digit at 1 kHz mod rate for deviation > 5 kHz	IFR* 2305
DVM	1 % accuracy AC measurement, 20 Hz to 50 kHz. DC measurement to 1 mV.	Solatron 7150+
Audio analyzer	Capable of measuring distortion from 1 kHz to 15 kHz down to 0.1% and AC measurement in a CCITT bandwidth.	IFR* 2965/ HP 8903B
LF generator	50 Hz to 50 kHz, external frequency standard In/Out, 30 mV to 5 V RMS.	IFR* 2965/ HP 3325
RF signal generator	100 kHz to 1.05 GHz, RF level accuracy ± 1 dB. AM depth 0 to 95%, deviation 0 to 75 kHz. Modulation rate 10 Hz to 15 kHz.	IFR* 2041
Power splitter	6 dB 50 Ω 500 kHz to 1 GHz.	Weinschel 1870A
DC PSU	0 to 50 V.	
Calibrated power source	Accuracy 3.5% up to 500 MHz, 8.5% up to 1 GHz.	See broad band power test.

The minimum specifications for the test equipment listed above cover *all* requirements for these tests. The minimum specifications for the test equipment listed at the start of each test description apply to that test only.

## RF output tests

### Carrier frequency accuracy

This check provides a conventional method of checking the signal generator frequency locking circuitry. It will confirm correct operation of phase lock loop and dividers. Overall accuracy is determined by the instrument's internal reference standard.

#### Specification

<b>Frequency range:</b>	400 kHz to 1.05 GHz
<b>Accuracy:</b>	As frequency standard $\pm 1$ count
<b>Resolution:</b>	10 Hz

#### Test equipment

Description	Minimum specification	Example
Frequency counter	400 kHz to 1.05 GHz , 1 Hz resolution, external standard In/Out	IFR 2440 or E.I.P.25B

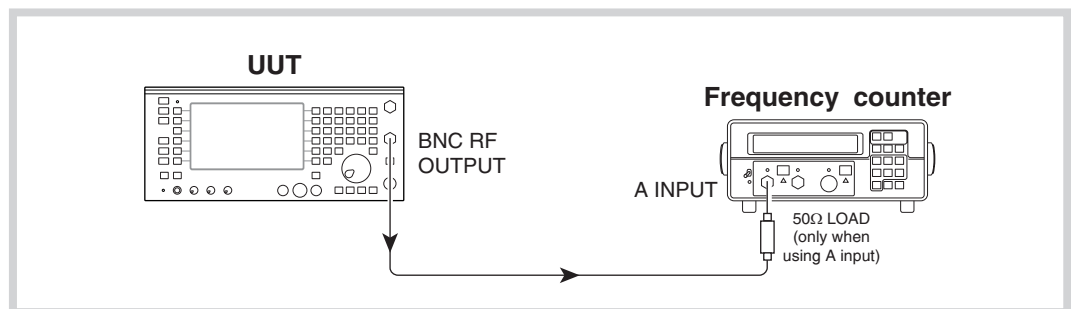

C6039

Fig. 5-1 Carrier frequency accuracy

- (1) Refer to Results table 5-1 on page 5-36. Connect the BNC RF output socket on the UUT to the A input on the counter (2440), as shown in Fig. 5-1. The connection to the A input should be made via a 50  $\Omega$  load, otherwise miscounting could occur.
- (2) Lock the reference standards of the instruments together.
- (3) Set the UUT to [Rx TEST], RF IN/OUT [SELECT] BNC output, [RF Gen], [LEVEL] 0 dBm, [FREQ] 400 kHz. All modulation and noise measurements should be switched OFF.
- (4) Set the counter to 1 Hz resolution.
- (5) Check that the counter reads between 399.999 and 400.001 kHz.
- (6) Repeat for the remaining frequencies shown in Table 5-1, checking that the counter displays the selected frequency  $\pm 1$  Hz. It will be necessary to disconnect the 50  $\Omega$  load and reconnect the UUT RF output to the A, B or C input of the counter where indicated.

**ACCEPTANCE TESTING**

---

**Table 5-1 Carrier frequencies**

Frequency	UUT area checked	2440 range
400.000 kHz 1050.00000 MHz 500.00000 MHz	Oscillator, bottom Oscillator, top Oscillator, middle	A C B
188.88888 MHz 177.77777 MHz 166.66666 MHz 155.55555 MHz 144.44444 MHz 133.33333 MHz 122.22222 MHz 111.11111 MHz	<div style="display: flex; align-items: center; justify-content: center;"> <span style="font-size: 3em; margin-right: 10px;">}</span> <span>Fractional N</span> <span style="font-size: 3em; margin-left: 10px;">}</span> </div>	B B B B B B B B



## RF output level

### Specification

**Level range:** -127 dBm to -21 dBm (N-type socket)

**Accuracy:**  $\pm 2$  dB up to 1 GHz

### Test equipment

Description	Minimum specification	Example
RF power meter	$\pm 0.1$ dB from 10 MHz to 1 GHz	IFR 6960/A/B + 6920 sensor
Measuring receiver	-21 dBm to -127 dBm, 2.5 MHz to 1 GHz	HP 8902A + 11772A sensor
Spectrum analyzer	Noise floor < -127 dBm	IFR 2383

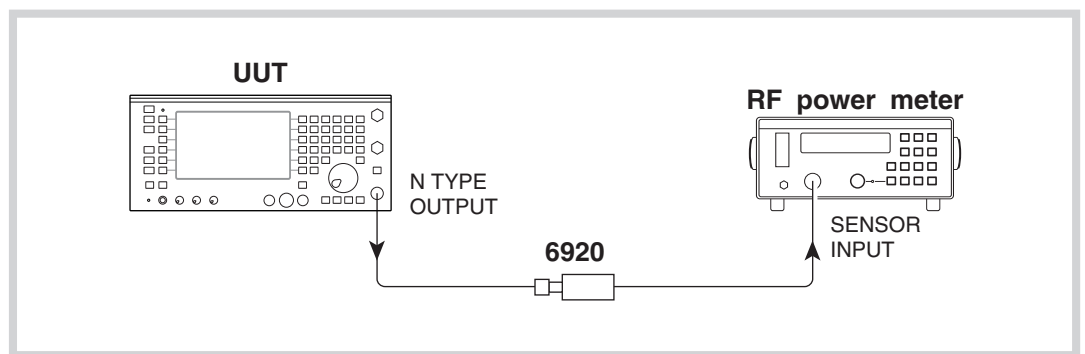

C6040

Fig. 5-2 RF level set up

- (1) Refer to Results table 5-2 on page 5-36. Connect the sensor to the UUT N-type output socket, as shown in Fig. 5-2.
- (2) Set the UUT to [Rx TEST], RF IN/OUT [SELECT] N-type output/antenna input mode, [RF Gen], [LEVEL] -21 dBm, [FREQ] 10 MHz. All modulation and noise measurements should be switched OFF.
- (3) Check that the power meter indicates  $-21 \text{ dBm} \pm 2 \text{ dB}$ .
- (4) Select N-type output/N-type input mode and check that the level measured is  $-21 \text{ dBm} \pm 2 \text{ dB}$ .
- (5) Press RF IN/OUT [SELECT] until the mode returns to N-type output/antenna input.
- (6) Repeat steps 3 to 5 for 100 MHz and then in 100 MHz steps up to and including 1000 MHz.

### ALC linearity

- (1) Refer to Results table 5-3 on page 5-37. Connect the sensor to the N-type output socket, as shown in Fig. 5-2.
- (2) Set the UUT to [RF Gen], [LEVEL] -21 dBm, [ $\Delta$  INC] 1 dB, [FREQ] 10 MHz.
- (3) Increment the RF output of the UUT in 1 dB steps down to -38 dBm, ensuring that the indication on the power meter is within  $\pm 2$  dB of each level set.
- (4) Return the UUT RF level to -21 dBm.
- (5) Set the UUT carrier frequency to 500 MHz and repeat step 3. Refer to Results table 5-4 on page 5-38.
- (6) Set the UUT carrier frequency to 1 GHz, return the level to -21 dBm and repeat step 3. Refer to Results table 5-5 on page 5-38.

### BNC output mode

No claim is made on the output level accuracy of the BNC socket. The following is a functional check to ensure correct internal operation.

- (1) Connect the 6920 sensor to the BNC output, as shown in Fig. 5-2.
- (2) Set the UUT to [Rx TEST], RF IN/OUT [SELECT] BNC output, [RF Gen], [LEVEL] -21 dBm, [FREQ] 10 MHz. All modulation and noise measurements should be switched OFF.
- (3) Check that the power meter indicates  $-21 \text{ dBm} \pm 4 \text{ dB}$ .
- (4) Repeat step 3 for 100 MHz and then in 100 MHz steps up to and including 1000 MHz.

### Attenuator accuracy

The following test will confirm that the attenuator performs to the published performance specification. In the event of the receiver not being available, an alternative method to functionally test the attenuator is also suggested.

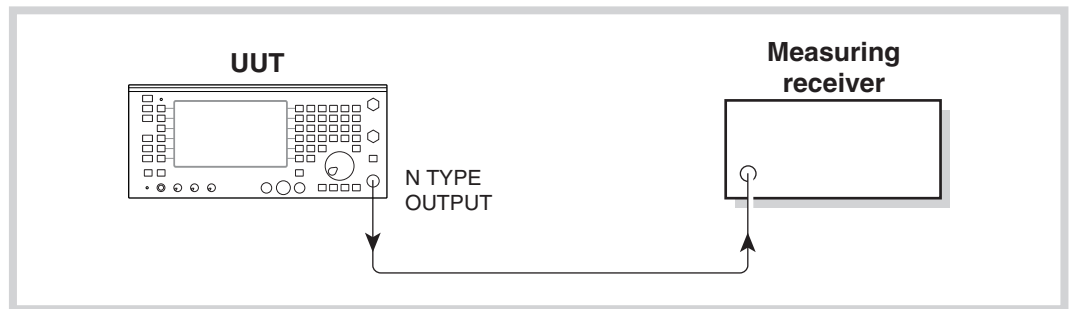

C6041

Fig. 5-3 Attenuator accuracy test set up

- (1) Connect the test equipment as shown in Fig. 5-3.
- (2) Set the UUT to [RF Gen], [LEVEL], -21 dBm, [FREQ] 2.5 MHz.
- (3) Tune the receiver to the frequency set on the UUT RF Generator and measure the RF level.
- (4) Decrement the output of the UUT in 10 dB steps down to an RF level of -121 dBm measuring the RF level at each step.
- (5) Repeat steps 2 to 4 for frequencies of 500 and 1000 MHz.

Alternative attenuator functional check

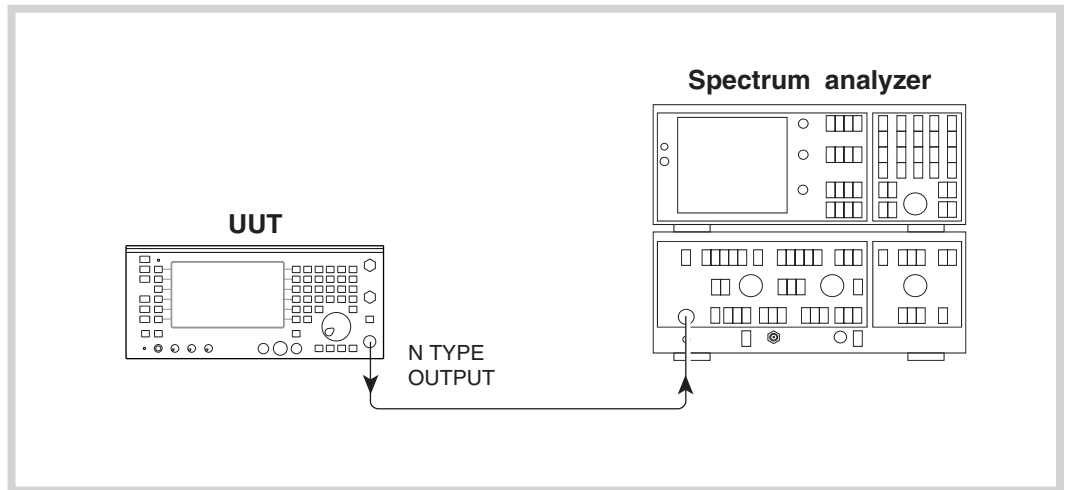

C6042

Fig. 5-4 Attenuator functional check

- (1) Connect the test equipment as shown in Fig. 5-4.
- (2) Set the UUT to [Rx TEST], RF IN/OUT [SELECT] N-type output, [RF Gen], [LEVEL] -27 dBm, [ $\Delta$  INC] 10 dB, [FREQ] 251 MHz. All modulation and noise measurements should be switched OFF.
- (3) Tune the Spectrum analyzer to the signal from the UUT. Using the UUT increment level down arrow key, reduce the level of the UUT output in 10 dB steps down to -127 dBm. At each 10 dB step ensure the level on the analyzer drops accordingly

## Spectral purity

### Harmonics, spurious, RF carrier leakage, residual FM.

#### Specification

<b>Carrier range:</b>	400 kHz to 1 GHz
<b>Harmonics:</b>	Better than $-20$ dBc.
<b>Spurious signals</b>	Better than $-30$ dBc ( $\pm 10$ kHz to 1.5 MHz offset from carrier frequency or over range 600 - 700 MHz). Better than $-40$ dBc elsewhere.
<b>Carrier leakage</b>	Less than $0.5 \mu\text{V}$ PD generated in a $50 \Omega$ load by a 2 turn 25 mm loop 25 mm from the case with output level less than $-40$ dBm and terminated in a sealed $50 \Omega$ load.
<b>Residual FM</b>	Less than 15 Hz RMS (0.3 to 3.4 kHz) up to 500 MHz Less than 20 Hz RMS (0.3 to 3.4 kHz) up to 1000 MHz (with OCXO)

#### Test equipment

Description	Minimum specification	Example
Spectrum analyzer	400 kHz to 3 GHz noise floor better than $-127$ dBm at 500 MHz	IFR 2383
$50 \Omega$ sealed load 2 turn 25 mm loop		
Low-noise FM demodulator	Residual FM to be less than 2 Hz up to 1 GHz	IFR 2305 + IFR 2041

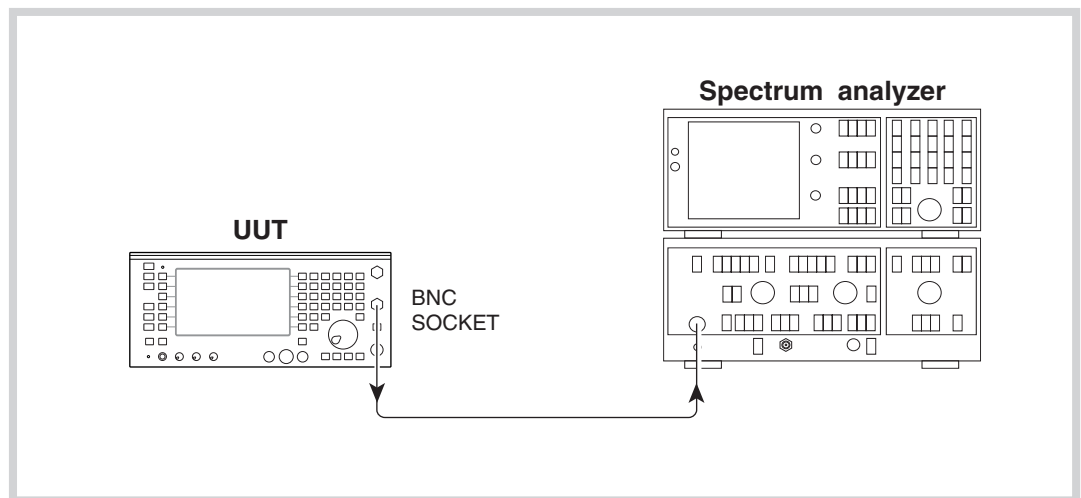

C6043

Fig. 5-5 Carrier harmonics & spurious check

- (1) Refer to Results table 5-6 on page 5-39. Connect the Spectrum analyzer to the BNC socket on the UUT, as shown in Fig. 5-5.
- (2) Set the UUT to [Rx TEST], RF IN/OUT [SELECT] BNC output, [RF Gen], [LEVEL] 0 dBm, [FREQ] 0.4 MHz. All modulation and noise measurements should be switched OFF.
- (3) Tune the Spectrum analyzer to view the harmonics shown in the second harmonic and third harmonic column of Results table 5-6, checking that they are within the above specification.
- (4) Repeat steps (2) and (3) for the remaining frequencies shown in the table.

- (5) Refer to Results table 5-7 on page 5-39. Set the UUT to [Rx TEST], RF IN/OUT [SELECT] BNC output, [RF Gen], [LEVEL] 0 dBm, [FREQ] 0.4 MHz.
- (6) Use the Spectrum analyzer to check that any spurious signals are  $< -40$  dBc. Repeat for UUT carrier frequencies of 500 MHz and 1000 MHz. Repeat for a UUT carrier frequency of 650 MHz checking that any spurious signals are  $< -30$  dBc.

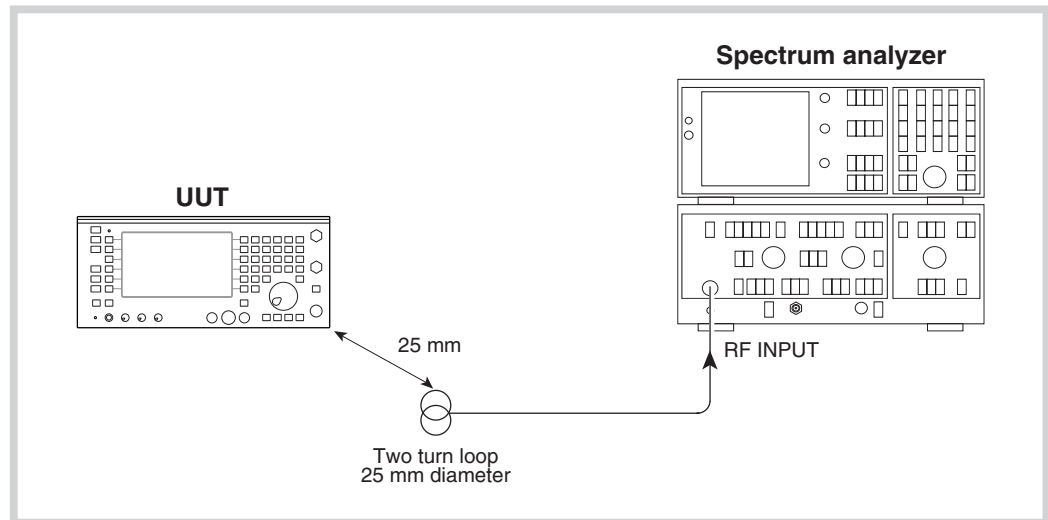

C6044

Fig. 5-6 RF carrier leakage check

- (7) Refer to Results table 5-8 on page 5-39. Connect the test equipment as shown in Fig. 5-6, with the 50  $\Omega$  load connected to the BNC socket of the UUT.
- (8) Set the UUT to [Rx TEST], RF IN/OUT [SELECT] BNC output, [RF Gen], [LEVEL]  $-40$  dBm, [FREQ] 501.9873 MHz.
- (9) Tune the Spectrum analyzer to monitor 501.9873 MHz. Set other Spectrum analyzer controls to allow the display of signals below  $-121$  dBm (if using the 2383, this can be set to meter mode).
- (10) Hold the loop 25 mm away from the UUT case and check that the level picked up on the Spectrum analyzer is less than  $0.5 \mu\text{V PD}$ .
- (11) To confirm the low residual FM of the UUT, the use of an extremely low-noise FM demodulator is necessary; this is achieved by using the IFR 2041 Low-noise signal generator as the local oscillator for the 2305. Connect the test equipment as shown in Fig. 5-7.

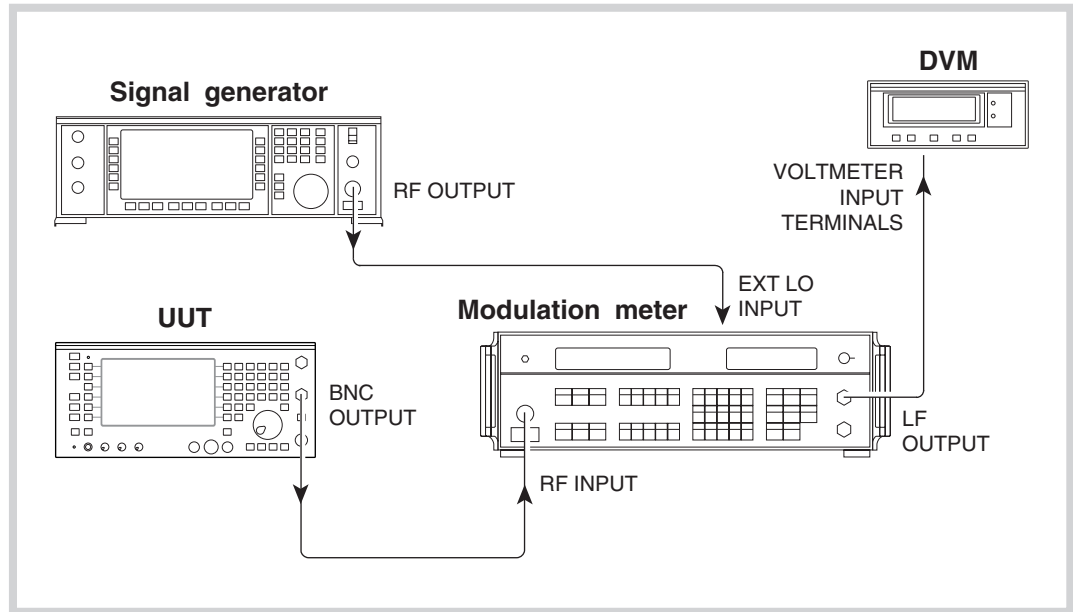

C6045

Fig. 5-7 Residual FM checks

- (12) Refer to Results table 5-9 on page 5-39. Set the UUT to [Rx TEST], RF IN/OUT [SELECT] BNC output, [RF Gen], [LEVEL] 0 dBm, [FREQ], 1000 MHz, [Mod Gen], [Gen1/Gen2], to select modulation generator 2, and then [LEVEL], 1 kHz. After this key sequence modulation generator 2 should be providing 1 kHz deviation at 1 kHz modulation rate. Modulation generator 1 should be OFF.
- (13) Set the signal generator into low noise mode 1 and to provide a signal of 55.63889 MHz at 0 dBm.
- (14) Set the Modulation meter to measure FM in a 300 Hz to 3.4 kHz bandwidth with noise averaging on. Select external LO by pressing FREQ TUNE, 0, ENTER. External LO should now appear in the top left of the modulation window display and the frequency window should display the IF frequency of 1.5 MHz  $\pm$  150 kHz. Note the DEVIATION LEVEL (Hz) displayed on the modulation meter. Set the LF LEVEL control on the front panel of the modulation meter to the horizontal mark and press HOLD ON/OFF.
- (15) Set the DVM to measure AC volts and make a note of the voltage displayed MOD VOLTAGE (V).
- (16) On the UUT press [ON/OFF] to switch modulation generator 2 OFF, then note the RESIDUAL VOLTAGE (V) displayed on the DVM.
- (17) The residual FM in HZ RMS. can now be calculated as follows:-

$$\text{RESIDUAL FM} = \frac{\text{RESIDUAL VOLTAGE} \times \frac{\text{DEVIATION LEVEL}}{\sqrt{2}}}{\text{MOD VOLTAGE}}$$

- (18) Set the UUT RF Generator and the local oscillator to the frequencies shown in Results table 5-9, confirming that the residual FM indicated on the Modulation meter is within the limits shown in the right hand column.

## Amplitude modulation

### Specification

<b>Carrier range:</b>	400 kHz to 1.05 GHz
<b>Resolution:</b>	1%
<b>Accuracy (up to 85% AM) Carrier frequency 1.5 to 400 MHz.</b>	±7% of setting ± 1 digit for modulation frequency 1 kHz. ±10% of setting ± 1 digit for modulation frequencies of 50 Hz to 5 kHz. ±15% of setting ±1 digit for modulation frequencies from 50 Hz to 15 kHz.
<b>Distortion:</b>	Less than 2% at 1 kHz for modulation depth 30% , CCITT weighted.

### Test equipment

Description	Minimum specification	Example
Modulation meter	RF I/P 500 kHz to 400 MHz AM Measurement accuracy up to 85% depth:- ±1% of reading at 1 kHz mod rate. ±2.5% of reading for mod rates from 50 Hz to 15 kHz	IFR 2305

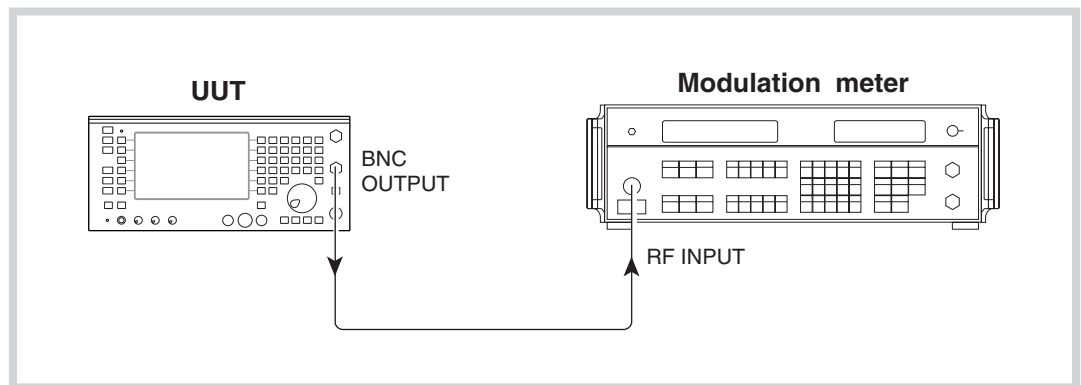

C6046

Fig. 5-8 Internal AM accuracy checks

- (1) Refer to Results table 5-10 on page 5-40. Connect the test equipment as shown in Fig. 5-8 (BNC output socket on UUT).
- (2) Set the UUT to [Rx TEST], RF IN/OUT [SELECT] BNC output, [RF Gen], [LEVEL] 0 dBm, [FREQ] 1.5 MHz, [Mod Gen], [Gen 2], [FREQ] 1 kHz, [LEVEL] 50%.
- (3) Set the Modulation meter to monitor AM in a 0.3 to 3.4 kHz bandwidth.
- (4) Check the Modulation meter for a reading within ±7% of setting ± 1 digit.
- (5) Repeat step 4, but with the UUT RF generator set to each of the remaining carrier frequencies shown in the Results table 5-10 on page 5-40.
- (6) Refer to Results table 5-11 on page 5-40. Set the UUT to [RF Gen], [FREQ] 100 MHz, [LEVEL] 5 dBm, [Δ INC] 1 dB, [Mod Gen], [Gen 2], [LEVEL] 70% and check the Modulation meter for a reading within ±7% of setting ±1 digit. Using the level decrement arrow key, decrement the RF level by 1 dB and repeat check. Repeat in 1 dB decrements down to -15 dBm.
- (7) Refer to Results table 5-12 on page 5-41. Set the UUT to [RF Gen], [LEVEL] 0 dBm, [Mod Gen], [Gen 2], [LEVEL] 5%.

## ACCEPTANCE TESTING

---

- (8) Check that the Modulation meter reads within  $\pm 7\%$  of setting  $\pm 1$  digit. Repeat for UUT AM depths of 10, 20, 30, 40, 50, 60, 70, and 85%.
- (9) *Refer to Results table 5-13 on page 5-41.* On the UUT, press [FREQ] 65 Hz to set Mod Gen 2 to 65 Hz.
- (10) Set the Modulation meter to monitor AM in a 30 Hz to 50 kHz flat bandwidth.
- (11) Check the Modulation meter for a reading within  $\pm 10\%$  of setting  $\pm 1$  digit.
- (12) Repeat step 11 with the UUT set to each of the following mod rates:- 140 Hz, 500 Hz, 2 kHz, and 5 kHz.
- (13) Set the UUT mod rate to 15 kHz and check the Modulation meter for a reading within  $\pm 15\%$  of setting  $\pm 1$  digit.
- (14) *Refer to Results table 5-14 on page 5-41.* Reset Mod Gen 2 frequency to 1 kHz and level to 30%.
- (15) Set the Modulation meter to monitor AM in a 0.3 to 3.4 kHz bandwidth.
- (16) Connect the LF output from the Modulation meter to the AF input on the UUT. Select the 0.3 to 3.4 kHz AF Filter on the UUT and select distortion measurement.
- (17) Check that the distortion indicated on the UUT display is less than 2 %.



## Frequency modulation

### Specification

<b>Carrier range</b>	400 kHz to 1.05 GHz
<b>Accuracy<sup>†</sup></b>	$\pm 5\% \pm 10$ Hz at 1 kHz modulating frequency. $\pm 10\%$ for modulating frequencies from 50 Hz to 15 kHz.
<b>Distortion</b>	Less than 1% at 1 kHz for deviation of 5 kHz, CCITT Weighted.

<sup>†</sup> At low modulation levels the residual AM/FM may become significant

### Test equipment

Description	Minimum specification	Example
Modulation meter	RF I/P 500 kHz to 1.05 GHz FM Measurement accuracy $\pm 0.5\%$ of reading $\pm 1$ least significant changing digit at 1 kHz mod rate for deviation >5 kHz	IFR 2305

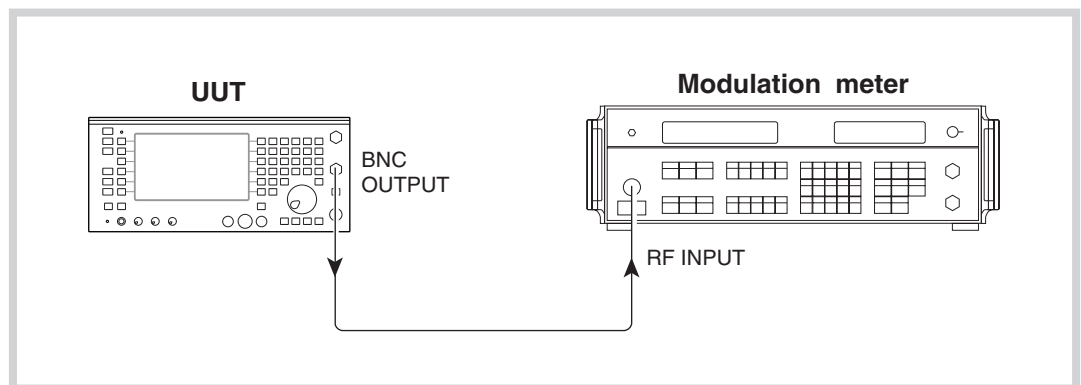

C6046

Fig. 5-9 Internal FM accuracy checks

- (1) Refer to Results table 5-15 on page 5-42. Connect the test equipment as shown in Fig. 5-9. (BNC output on UUT).
- (2) Set the UUT to [Rx TEST], RF IN/OUT [SELECT] BNC output, [RF Gen], [LEVEL] 0 dBm, [FREQ] 0.5 MHz, [Mod Gen], [Gen 2], [LEVEL] 10 kHz, [FREQ] 1 kHz. All other modulation generators and noise measurements should be switched OFF.
- (3) Set the Modulation meter to monitor FM in a 50 Hz to 15 kHz bandwidth, Noise averaging on.
- (4) Check the Modulation meter indicates a reading within  $\pm 5\% \pm 10$  Hz of the deviation set. Repeat with the UUT set to each of the remaining carrier frequencies shown in the Results table 5-15.
- (5) Refer to Results table 5-16 on page 5-42. Set the UUT to [RF Gen], [FREQ] 600 MHz, [Mod Gen], [Gen 2], [LEVEL] 75 kHz.
- (6) Check the modulation meter indicates a reading within  $\pm 5\% \pm 10$  Hz of the deviation set. Repeat with the UUT set to provide deviations of 50 kHz, 25 kHz and 5 kHz.
- (7) Refer to Results table 5-17 on page 5-42. With the deviation still set at 5 kHz, connect the LF output of the Modulation meter to the AF input of the UUT. (Set the LF [LEVEL] control to the brown marker on the Modulation meter.)
- (8) Select the 0.3 to 3.4 kHz AF Filter on the UUT and select distortion measurement.
- (9) Check that the distortion indicated on the UUT is less than 1%.
- (10) Switch distortion measurement off.

## ACCEPTANCE TESTING

---

- (11) *Refer to Results table 5-18 on page 5-42.* Set the UUT Mod Gen 2 to provide 10 kHz deviation level at a frequency of 50 Hz.
- (12) Select the 30 Hz to 50 kHz filter on the Modulation meter.
- (13) Check that the Modulation meter reads 10 kHz deviation  $\pm 10\% \pm 10$  Hz. Repeat for UUT modulation frequencies of 10 kHz and 15 kHz.

## AF output tests

### Audio generator output level

#### Specification

<b>Level range:</b>	0.1 mV to 4 V RMS
<b>Accuracy:</b>	$\pm 5\% \pm 1$ resolution 50 Hz to 15 kHz

#### Test equipment

Description	Minimum specification	Example
DVM	1 % accuracy 50 Hz to 15 kHz	Solatron 7150+

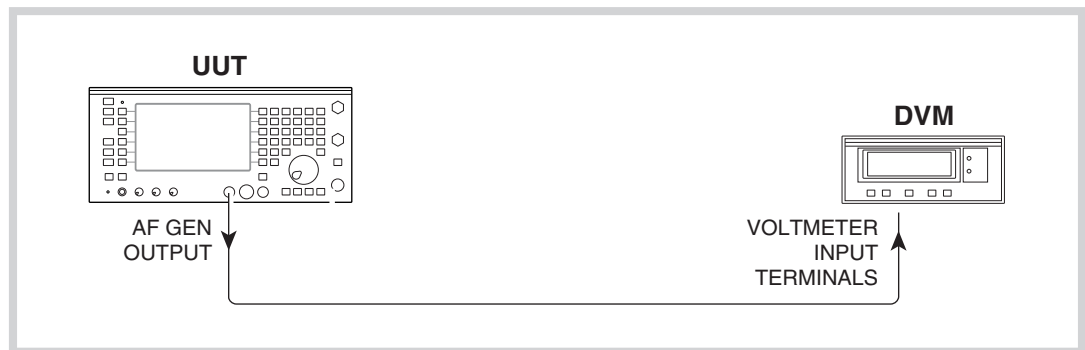

C6047

Fig. 5-10 Audio generator level accuracy checks

- (1) Refer to Results table 5-19 on page 5-43. Connect the test equipment as shown in Fig. 5-10, connecting the UUT AF Gen output socket to the DVM voltmeter input terminals.
- (2) Set the DVM to measure Volts AC RMS.
- (3) Set the UUT to [AF TEST], [Audio Gen] 1 [FREQ] 1 kHz, [LEVEL] 4 V. Audio Gen 1 should be set to Sinewave and Audio Gen 2 should be OFF. Check that the DVM reads the level set  $\pm 5\% \pm 1$  mV. Repeat with frequencies of 50 Hz, 150 Hz, 500 Hz, 2 kHz, 5 kHz, 10 kHz and 15 kHz in turn, checking that the DVM reads the level set  $\pm 5\% \pm 1$  mV.
- (4) Set the UUT to [AF Gen 1], [FREQ] 1 kHz, [LEVEL] 20.0 mV. Repeat with the level set to 400 mV. Check that for each level the DVM reads the level set  $\pm 5\% \pm 0.1$  mV. Repeat with the level set, in turn, to 1000 mV, 2000 mV and 3000 mV, and check that in each case the DVM reads the level set  $\pm 5\% \pm 1$  mV.
- (5) Refer to Results table 5-20 on page 5-43. Repeat the above checks for AF Gen 2 with AF Gen 1 switched OFF.

## Audio generator distortion

### Specification

<b>Distortion:</b>	Less than 0.5% at 1 kHz. Less than 1% from 50 Hz to 15 kHz .
--------------------	---

### Test equipment

Description	Minimum specification	Example
Distortion analyzer	Capable of measuring distortion from 1 kHz to 15 kHz down to 0.1%.	IFR 2965 or HP8903B

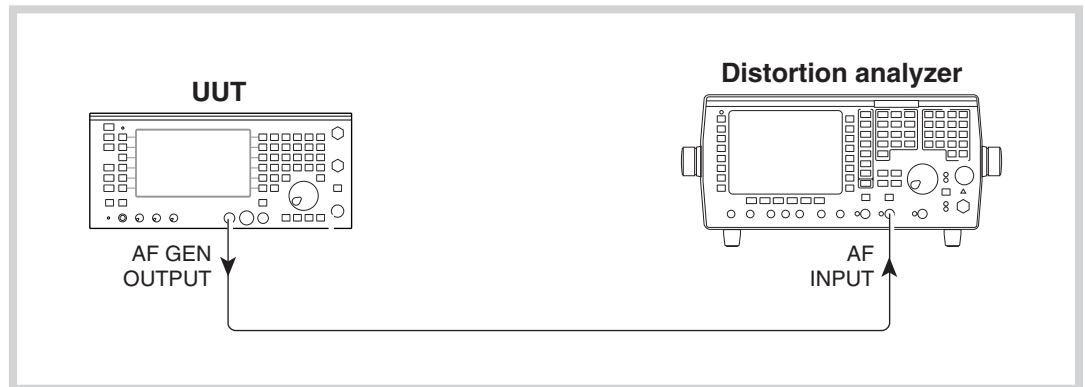

C6048

Fig. 5-11 Audio generator signal purity checks

- (1) Refer to Results table 5-21 on page 5-44. Connect the UUT AF GEN output to the AF input of the distortion meter, as shown in Fig. 5-11.
- (2) Set the UUT to [AF TEST], [Audio Gen], [FREQ] 1 kHz, [LEVEL] 4 V. Audio Gen 1 should be set to sinewave and Audio Gen 2 should be OFF.
- (3) Set the Distortion meter to measure distortion at 1 kHz in a 0.3 to 3.4 kHz bandwidth..
- (4) Check that the distortion indicated is less than 0.5%.
- (5) Repeat step (4) with AF Gen 1 level set to 100 mV.
- (6) Set the Distortion meter to measure distortion in a 20 kHz Low-pass bandwidth.
- (7) Set AF Gen 1 to provide 4 V at a frequency of 2 kHz. Check that the distortion indicated on the Distortion meter is less than 1%. (If a 2965 is being used, see the Operating Manual for instructions on setting distortion measurement to different frequencies.) Repeat at 5 kHz. Set the low-pass bandwidth on the distortion meter to NONE and repeat with AF Gen 1 set to provide 15 kHz.
- (8) Refer to Results table 5-22 on page 5-44. Repeat the above procedure, except this time with AF Gen 1 switched OFF and AF Gen 2 ON.

## Audio generator frequency

This is a functional check only. The Audio generator frequency is derived digitally and provided that the hardware is operational its accuracy will be maintained. The instrument's internal reference frequency is checked elsewhere. This check is listed at this point as it is one of the AF generator tests, but it should be carried out after the UUT audio frequency meter has been checked (see *AF input tests; AF frequency meter*).

### Specification

<b>Frequency accuracy:</b>	0.01 Hz $\pm$ frequency standard < 180 Hz
	0.1 Hz $\pm$ frequency standard >180 Hz

- (1) *Refer to Results table 5-23 on page 5-44.* Connect the UUT AF GEN OUT socket to the UUT AF INPUT socket.
- (2) Set the UUT to [AF TEST], [AF Filter], [50 kHz LP] to set the Audio Input filter to 50 kHz Low-pass.
- (3) Set [Audio Gen], [LEVEL] 1 V, [FREQ] 10 Hz. Audio generator 2 should be switched OFF. Check that the frequency indicated on the UUT audio counter is within the limits shown in *Results table 5-23*. Repeat with the remaining frequencies shown in the table.
- (4) *Refer to Results table 5-24 on page 5-45.* Repeat checks with AF GEN 2.

## AF input tests

### Audio frequency meter

This test confirms the accuracy of the audio counter hardware. Overall accuracy is governed by the instrument reference frequency. The reference is checked independently elsewhere. Note: If the LF generator is not available then the Audio generator frequency check will confirm that the audio frequency meter is functional.

### Specification

<b>Frequency range:</b>	20 Hz to 20 kHz
<b>Resolution:</b>	0.1 Hz, less than 10 kHz 1 Hz, at 10 kHz and above.
<b>Accuracy:</b>	As frequency standard $\pm$ digit $\pm$ resolution
<b>Sensitivity:</b>	50 mV

### Test equipment

Description	Minimum specification	Example
LF generator	20 Hz to 20 kHz frequency external standard In/Out	HP 3325B
DVM	1 % accuracy 20 Hz to 20 kHz	Solatron 7150+

- (1) Refer to Results table 5-25 on page 5-45. Connect the equipment as shown in Fig. 5-12 connecting to the UUT AF input socket. The frequency standards of the UUT and LF generator should be locked together. The 50  $\Omega$  load is in circuit because the LF generator used indicates level across 50  $\Omega$ .
- (2) Press [HELP/SETUP], [Setup], [AF Filters], [Factory Preset], [Return], [Return], [Return]. Set the UUT to [AF TEST]. Press [AF Filter], [50kHz LP] to set the Audio Input filter to 50 kHz Low-pass.
- (3) Set the DVM to monitor Volts AC.
- (4) Set the LF generator to the first frequency shown in the Results table 5-25, and adjust the level for an indication of 50 mV RMS on the DVM. Check that the frequency indicated on the UUT audio counter is within the limits shown. Repeat for the remaining frequencies in the table.

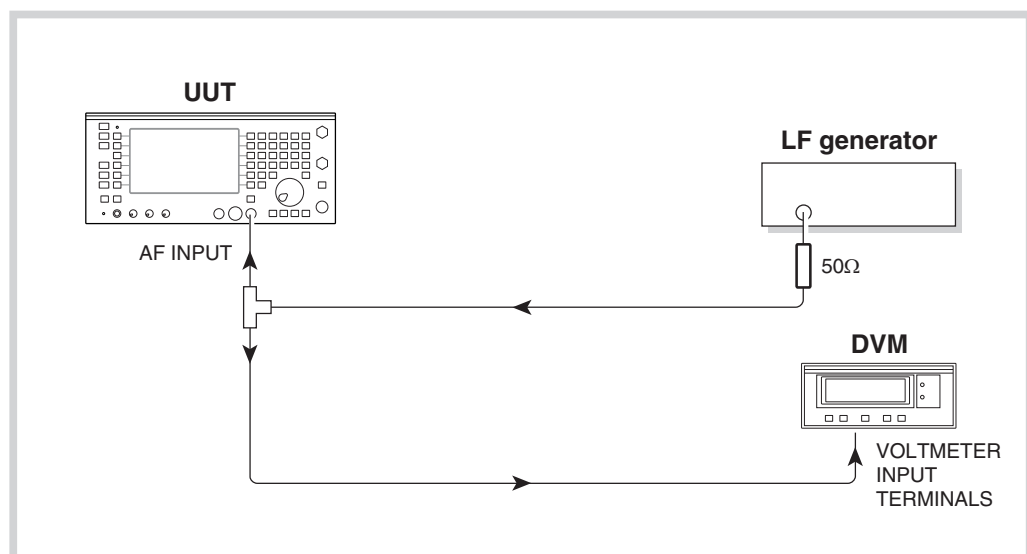

C6049

Fig. 5-12 Audio frequency meter check

## Audio voltmeter Specification

<b>Level accuracy:</b>	$\pm 3\% \pm 3 \text{ mV} \pm \text{resolution}$ 20 Hz to 50 kHz (DC and 20 Hz to 50 kHz when DC coupled)
<b>Resolution:</b>	1 mV or 1% of reading.

## Test equipment

Description	Minimum specification	Example
LF generator	50 Hz to 50 kHz 30 mV to 5 V RMS.	IFR 2965
DC power supply	0 to 50 V	
DVM	DC measurement and AC measurement 20 Hz to 50 kHz.	Solatron 7150+

- (1) Refer to Results table 5-26 on page 5-46. Connect the equipment as shown in Fig. 5-13, connecting the LF generator output to the UUT AF input and via a T-piece to a DVM.
- (2) Press [HELP/SETUP], [Setup], [AF Filters], [Factory Preset], [Return], [Return], [Return]. Set the UUT to [AF TEST] press [AF Filter], [50 kHz LP] to set the Audio Input filter to 50 kHz Low-pass. Press AC/DC coupling until AC coupled is displayed.
- (3) Set the DVM to measure Volts AC and the LF generator to frequency 1 kHz, level 30 mV RMS (adjust until the DVM indicates as close to 30 mV as possible). Check that the level indicated on the UUT voltmeter is within  $\pm 3\% \pm 3 \text{ mV} \pm \text{resolution}$  of the level indicated on the DVM.
- (4) Repeat step 3 with LF generator levels of 200 mV, 0.4 V, 0.8 V, 2 V, 4.5 V.
- (5) This step is a functional check only and confirms that the audio filters switch in correctly with minimal insertion loss. Press [HELP/SETUP], [Setup], [AF Filters], [Factory Preset], [Return], [Return], [Return].
  - Set the UUT AF filter to 15 kHz LP and check that the UUT voltmeter indicates within  $\pm 6\% \pm 3 \text{ mV} \pm \text{resolution}$  of the level measured with the 50 kHz LP.
  - Repeat with the 300 to 3.4 kHz BP filter.
  - Repeat with the 50 to 15.0 kHz BP filter.
  - Set the LF generator to 100 Hz and set the UUT filter back to 50 kHz LP. Note the reading and then set the UUT filter to 300 Hz LP. Check that the UUT voltmeter indicates within  $\pm 6\% \pm 3 \text{ mV} \pm \text{resolution}$  of the level measured with the 50 kHz LP.

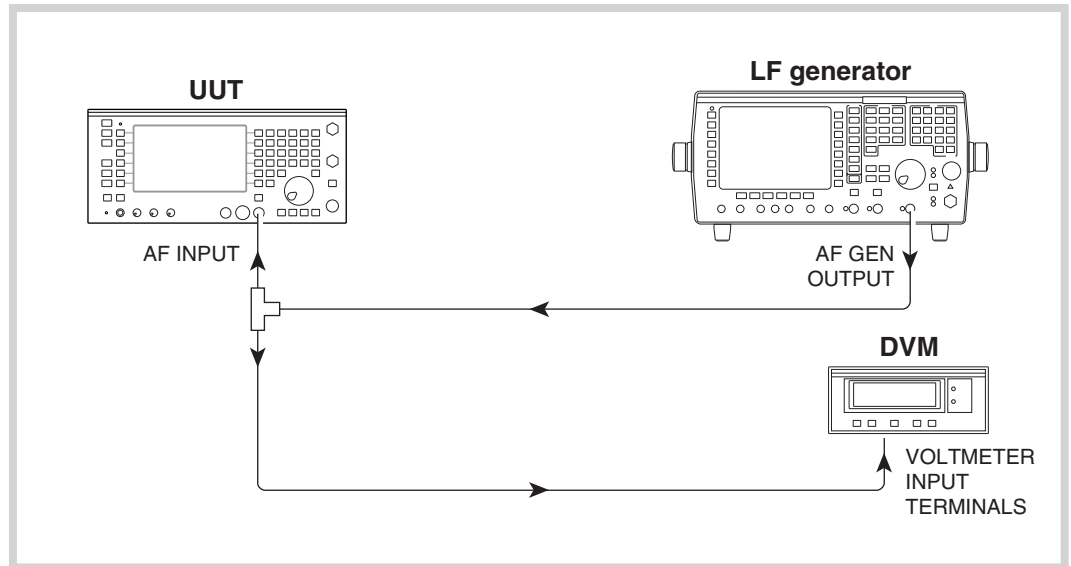

C6040

Fig. 5-13 Audio voltmeter level accuracy checks

- (6) Set the UUT AF filter to 50 kHz LP.
- (7) Set the LF generator to frequency 50 Hz level 1 V RMS (adjust until DVM indicates as close to 1 V as possible). Check that the level indicated on the UUT voltmeter is within  $\pm 3\%$   $\pm 3$  mV  $\pm$  resolution of the level indicated on the DVM.
- (8) Repeat step 7 with LF generator frequencies of 100 Hz, 500 Hz, 10 kHz, 30 kHz and 50 kHz.
- (9) Set the UUT AF input to DC coupled and substitute the LF generator with the DC power supply. Set the external DVM to monitor DC volts.
- (10) Set the DC supply to 25 V (adjust until DVM indicates as close to 25 V as possible). Check that the level indicated on the UUT voltmeter is within  $\pm 3\%$   $\pm 3$  mV  $\pm$  resolution of the level indicated on the DVM. Repeat this step with the DC supply set to 50 V.



## Audio oscilloscope

### Specification

<b>Voltage accuracy:</b>	±5% of full scale DC to 50 kHz (3 Hz to 50 kHz AC coupled).
<b>Ranges:</b>	10 mV/div to 20 V/div in a 1, 2, 5 sequence.
<b>Graticule:</b>	10 horizontal by 6 vertical.

### Test equipment

Description	Minimum specification	Example
LF generator	10 Hz to 20 kHz 10 mV to 12 V peak to peak.	IFR 2965
DVM	DC measurement and AC measurement 20 Hz to 20 kHz.	Solatron 7150+
DC PSU	0 to 30 V	

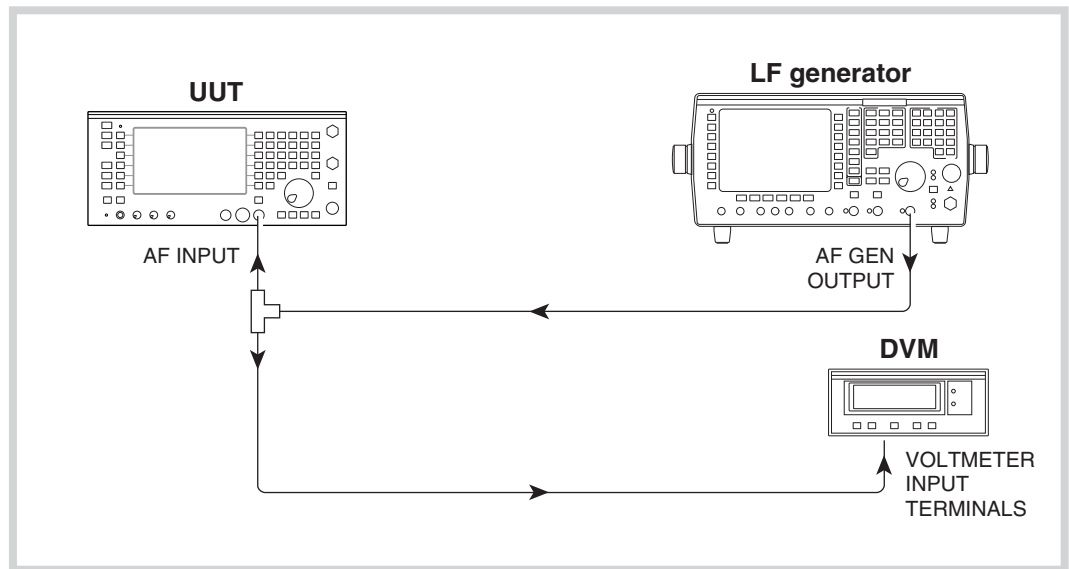

C6040

Fig. 5-14 Audio oscilloscope check

- (1) Refer to Results table 5-27 on page 5-46. Connect the equipment as shown in Fig. 5-14, connecting to the AF input of the UUT.
- (2) Set the UUT to [AF TEST], [Scope/Bar], [Scope], [AC DC] set to AC coupling. Set the Scope timebase to 200  $\mu$ s/div.
- (3) Set the LF generator to provide 1 kHz at each of the levels shown in Results table 5-27, at the same time selecting the relevant vertical scale on the UUT. In each case adjust the LF generator level until the trace occupies the full six divisions. Set the DVM to measure Volts AC. Note the level on the DVM and check that it lies within the limits shown in the table.
- (4) Disconnect the LF generator.
- (5) Set the UUT oscilloscope to 5 V/div and the AF input to DC coupled. With no signal applied use the front panel SCOPE position control to set the trace onto the bottom graticule line.
- (6) Set the DVM to measure DC volts.

- (7) Connect the DC supply in place of the LF generator and adjust its level until the oscilloscope trace sits on the graticule line two divisions down from the top of the display. Check that the DVM indicates a level within the limits shown in the above table.
- (8) Temporarily remove the DC PSU, set the UUT oscilloscope to 10 V/div and use the front panel SCOPE position control to set the trace onto the bottom graticule line. Reconnect the DC PSU and adjust its level until the oscilloscope trace sits on the graticule line two divisions up from the bottom of the display. Check that the DVM indicates a level within the limits shown in the above table. Repeat for the final range shown in the above table but this time adjusting the DC PSU level until the trace sits on the graticule line 1 division up from the bottom of the display.
- (9) Remove the DC PSU and reconnect the LF generator. Set the DVM to measure Volts AC.
- (10) *Refer to Results table 5-28 on page 5-47.* Set the UUT to 1 V/div, 50 ms/div.
- (11) Set the LF generator to the first frequency shown in Results table 5-28 at the same time selecting the relevant timebase on the UUT. Adjust the LF generator level until the trace occupies the full six divisions. Note the level on the DVM and check that it lies within the limits shown in the table.

## AF distortion & SINAD meter

### Specification

<b>Frequency range:</b>	1 kHz.
<b>Distortion meter accuracy</b>	$\pm 5\%$ of reading $\pm 0.5\%$ distortion.
<b>SINAD meter accuracy</b>	$\pm 1$ dB.

- (1) *Refer to Results table 5-29 on page 5-47.* Connect UUT AF INPUT to UUT AF GEN OUT.
- (2) Set the UUT to [AF TEST], [Audio Gen], [FREQ] 1 kHz, [LEVEL] 1 V. Press [Gen 1/Gen2] to select AF Gen 2, then [FREQ] 400 Hz, [LEVEL] 20 mV, [ON]. This should cause AF Gen 1 to be set to 1 kHz, 1 V, and AF Gen 2 to 400 Hz, 20 mV. If these values are not set, make the required adjustments to achieve them.
- (3) Press [Return], [Audio Meter], [DIST/S-N], [DIST'N] to switch the UUT distortion meter on.
- (4) Check that the distortion meter reads between 1.4 and 2.6% distortion, i.e. 2% distortion  $\pm 5\%$  of reading  $\pm 0.5\%$  distortion.
- (5) Set AF Gen 2 level to 250 mV.
- (6) Select AF Gen 1 level and adjust until the UUT voltmeter reads 1.00 V.
- (7) Check that the distortion meter reads between 23.2 and 26.8% distortion, i.e. 25% distortion  $\pm 5\%$  of reading  $\pm 0.5\%$  distortion.
- (8) Press [Return], [DIST/S-N], [Sinad] to switch the UUT SINAD meter on.
- (9) Check that the SINAD meter reads 12 dB  $\pm 1$  dB.

## RF input tests

### Modulation analyzer - FM

#### Specification

<b>Frequency range:</b>	100 kHz to 1.05 GHz.
<b>Modulation frequency range:</b>	10 Hz to 15 kHz.
<b>Deviation range:</b>	0 to 75 kHz.
<b>Resolution:</b>	10 Hz below 2 kHz deviation 1% above 2 kHz deviation
<b>Accuracy (see Note 1)</b>	$\pm 5\%$ $\pm$ resolution at 1 kHz modulation frequency. $\pm 7.5\%$ $\pm$ resolution for modulation frequencies from 50 Hz to 10 kHz.
<b>Demodulation distortion</b>	Less than 2% at 1 kHz and 5 kHz FM,
<b>Demodulation scope accuracy</b>	$\pm 10\%$
<b>Demodulation output socket</b>	200 mV peak to peak $\pm 10\%$ per 1 kHz deviation
<b>Demodulation filters</b>	300 Hz LP, 300 Hz HP, 3 kHz LP, 0.3 to 3.4 kHz BP, 15 kHz LP, 50 kHz LP, 750 $\mu$ s de-emphasis
<b>Residual FM:</b>	Less than 30 Hz (300 Hz to 3.4 kHz)

**Note 1:**

At low modulation levels, the residual AM/FM may become significant.

#### Test equipment

Description	Minimum specification	Example
RF signal generator	5.5 MHz to 1 GHz Deviation 0 to 75 kHz Modulation rate 10 Hz to 15 kHz.	IFR 2041
Modulation meter	RF I/P 5.5 MHz to 1 GHz FM Measurement accuracy $\pm 0.5\%$ of reading $\pm 1$ least significant changing digit at 1 kHz mod rate for deviation $> 5$ kHz.	IFR 2305
Power splitter	6 dB 50 $\Omega$ 5.5 MHz to 1 GHz.	WEINSCHEL 1870A
DVM	1 % accuracy 1 kHz	Solatron 7150+

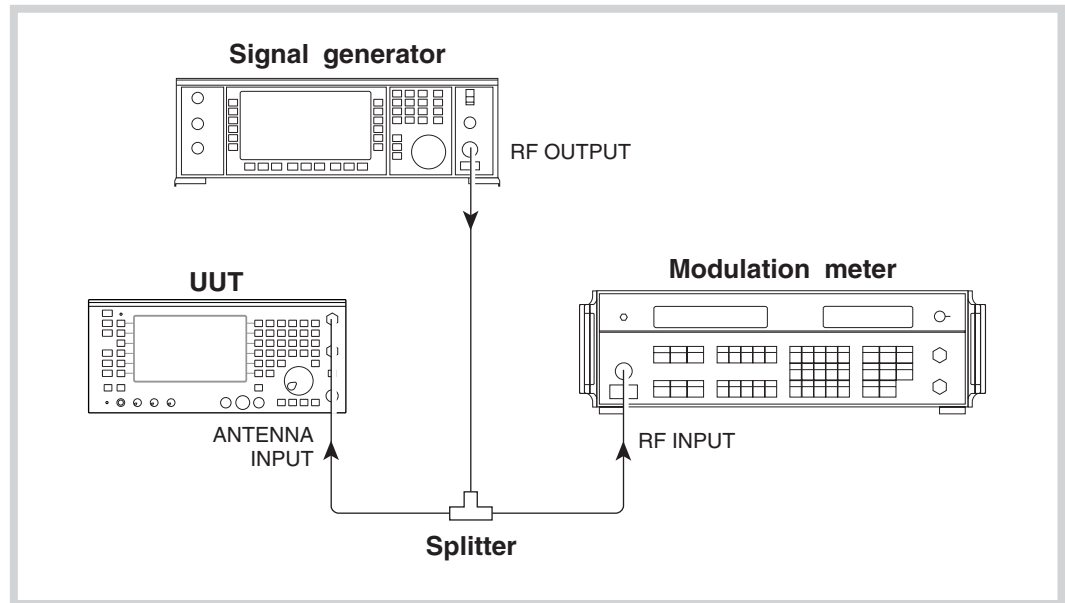

C6051

Fig. 5-15 Modulation meter FM

- (1) Refer to Results table 5-30 on page 5-47. Connect the equipment as shown in Fig. 5-15, connecting the incoming signal to the antenna input socket of the UUT.
- (2) Set the Modulation meter to monitor FM in a 50 Hz to 15 kHz bandwidth, noise averaging on.
- (3) Set the UUT to [Tx TEST], RF IN/OUT [SELECT] antenna BNC input socket. From the power up default, the instrument should already be set to demodulate FM with an IF filter of 30 kHz and AF filter of 0.3 to 3.4 kHz selected. Check that this is the case and select if necessary.
- (4) On the UUT, set [Tx Freq] 5.5 MHz. Set the RF signal generator to provide a signal of 5.5 MHz with 20 kHz deviation at 1 kHz modulation rate. Set the RF level to 6 dBm. (If a 2041 is being used then it should be set to normal noise mode.)
- (5) Check that the deviation level indicated on the UUT is within  $\pm 5\% \pm$  resolution of the deviation indicated on the external Modulation meter.
- (6) Repeat steps 4 and 5 for RF carrier frequencies of 500 MHz and 1000 MHz.
- (7) Manually tune the UUT to 300 MHz and set the RF signal generator to provide 300 MHz with 20 kHz deviation.
- (8) Select the 50 kHz low-pass filter by pressing [return], [Mod Meter], [AF Filter], [50kHz LP], and check the UUT still indicates 20 kHz deviation. (Functional check only.)
- (9) Select the 300 Hz high-pass filter by pressing [more], [300Hz HP], and check that the UUT still indicates 20 kHz deviation. (Functional check only.)
- (10) Select the 3 kHz low-pass filter and check that the UUT still indicates 20 kHz deviation. (Functional check only.)
- (11) Refer to Results table 5-31 on page 5-47. Select the 300 Hz low-pass filter by pressing [more], [300Hz LP].
- (12) Set the RF signal generator to provide a signal of 300 MHz with 20 kHz deviation at 50 Hz modulation rate. On the external Modulation meter select the 10 Hz to 300 kHz filter. Check that the deviation level indicated on the UUT is within  $\pm 7.5\% \pm$  UUT resolution of the deviation indicated on the modulation meter.
- (13) Set the RF signal generator modulation rate to 5 kHz and the UUT AF Filter to 15 kHz LP. Check that the deviation level indicated on the UUT is within  $\pm 7.5\% \pm$  UUT resolution of the deviation indicated on the Modulation meter.

## ACCEPTANCE TESTING

---

- (14) Set the RF signal generator modulation rate to 10 kHz and the UUT AF Filter to 50 kHz LP. Check that the deviation level indicated on the UUT is within  $\pm 7.5\% \pm$  UUT resolution of the deviation indicated on the Modulation meter.
- (15) Refer to Results table 5-32 on page 5-47. On the UUT select an AF filter of 0.3 to 3.4 kHz and an IF filter of 3 kHz.
- (16) Set the external Modulation meter bandwidth to 50 Hz to 15 kHz.
- (17) Set the RF signal generator modulation rate to 1 kHz and set 250 Hz deviation.
- (18) Check that the deviation level indicated on the UUT is within  $\pm 5\% \pm$  UUT resolution of the deviation indicated on the Modulation meter..
- (19) On the UUT select an IF filter of 30 kHz . Set the RF signal generator to provide a deviation of 10 kHz and check that the deviation level indicated on the UUT is within  $\pm 5\% \pm$  UUT resolution of the deviation indicated on the Modulation meter.
- (20) On the UUT select an IF filter of 300 kHz. Set the RF signal generator to provide a deviation of 50 kHz and check that the deviation level indicated on the UUT is within  $\pm 5\% \pm$  UUT resolution of the deviation indicated on the Modulation meter. Repeat at 75 kHz.
- (21) Refer to Results table 5-33 on page 5-48. Select the UUT demodulation oscilloscope by pressing [Return], [Scope/Bar], [Scope]. Using the oscilloscope horizontal and vertical soft keys select a vertical scale of 25 kHz/div and a horizontal scale of 200  $\mu$ s/div.
- (22) Adjust the deviation level from the RF signal generator until the 1 kHz trace on the oscilloscope occupies the full six deviations.
- (23) Check that the deviation indicated on the external Modulation meter is between 67.5 and 82.5 kHz.
- (24) Adjust the deviation level from the RF signal generator until the external Modulation meter reads 75.0 kHz deviation. Leave all settings unaltered while carrying out step 25.
- (25) Refer to Results table 5-34 on page 5-48. Connect the DEMOD OUT socket on the rear of the UUT to the DVM. Set the DVM to monitor Volts AC and check that the level indicated is between 4.77 V and 5.83 V.
- (26) Set the RF signal generator modulation rate to 2 kHz.
- (27) On the UUT press [Return], [Mod Meter], [Deemph] to switch de-emphasis on.
- (28) Check that the deviation reading on the UUT drops by approximately half, i.e. to 37.5 kHz. (functional check).
- (29) Press [Deemph] to switch the de-emphasis filter off and then [Return], [Scope/Bar], [Bar Chart], [Return], to switch the oscilloscope off.
- (30) Remove the splitter and Modulation meter and connect the RF signal generator directly to the UUT antenna input.
- (31) Refer to Results table 5-35 on page 5-48. Set the RF signal generator to provide a signal of 300 MHz at 6 dBm with 5 kHz deviation at 1 kHz modulation rate.
- (32) On the UUT select the 0.3 to 3.4 kHz AF filter and the 30 kHz IF filter.
- (33) On the UUT switch distortion measurement ON and check that the distortion reading indicates less than 2%.
- (34) Set the UUT to [Tx FREQ] 300 MHz and set the RF signal generator to provide a signal of 300 MHz with 5 kHz deviation at 1 kHz modulation rate. (The 2041 should be set to low noise mode.)
- (35) Note the voltage reading on the DVM connected to the DEMOD OUT socket of the UUT (Reading 1).
- (36) Switch the RF signal generator modulation off and note the reading on the DVM (Reading 2).
- (37) Calculate the residual FM as shown below and check that it indicates 35 Hz or less (functional check only).

$$(\text{Reading 2} \div \text{Reading 1}) \times 5000$$

## Modulation analyzer - AM

### Specification

<b>Frequency range:</b>	100 kHz to 1.05 GHz.
<b>Modulation frequency range:</b>	10 Hz to 15 kHz.
<b>AM depth range:</b>	0 to 99% (manually tuned) 0 to 90% below 100 MHz 0 to 80% from 100 to 400 MHz
<b>Resolution:</b>	1% AM
<b>Accuracy (see Note 1)</b>	±5% of reading ±1 digit at 1 kHz. ±8.5% of reading ±1 digit from 50 Hz to 10 kHz
<b>Demodulation distortion (1):</b>	Less than 2% at 1 kHz & 30% AM (CCITT weighted).
<b>Residual AM:</b>	Less than 1% (0.3 to 3.4 kHz)

**Note 1:**

(1) At low modulation levels, the residual AM/FM may become significant.

### Test equipment

Description	Minimum specification	Example
RF signal generator	500 kHz to 1 GHz AM depth 0 to 95% Modulation rate 30 Hz to 15 kHz.	IFR 2041
Modulation meter	RF I/P 500 kHz to 1 GHz AM Measurement accuracy ±1% of reading ±1 least significant changing digit at 1 kHz mod rate for depths up to 95%.	IFR 2305
Power splitter	6 dB 50 Ω 500 kHz to 1 GHz.	WEINSCHEL 1870A

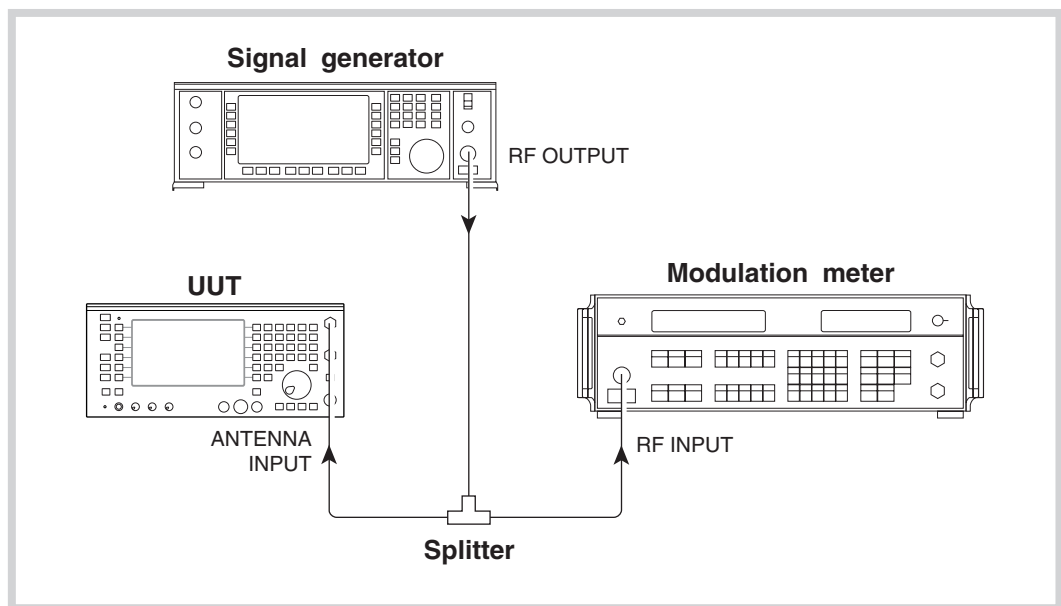

C6051

Fig. 5-16 Modulation analyzer — AM

## ACCEPTANCE TESTING

---

- (1) Refer to Results table 5-36 on page 5-48. Connect the equipment as shown in Fig. 5-16, connecting the incoming signal to the antenna input socket of the UUT.
- (2) Set the Modulation meter to monitor AM in a 50 Hz to 15 kHz bandwidth, Noise averaging on. Press [HELP/SETUP], [Setup], [AF Filters], [Factory Preset], [Return], [Return], [Return].
- (3) Set the UUT to [Tx TEST], RF IN/OUT [SELECT] antenna input socket, [Mod Meter]. Press the [AM/FM] soft key to set the UUT to demodulate AM. From the power up default, the instrument should already have an IF filter of 30 kHz and AF filter of 0.3 to 3.4 kHz selected. Check that this is the case and select if necessary.
- (4) Tune the UUT to 500 kHz by pressing [Return], [Tx Freq] 500 kHz. Set the RF signal generator to provide a signal of 500 kHz with 70% AM at 1 kHz modulation rate. Set the RF level to 6 dBm. (If a 2041 is being used, it should be set to normal noise mode.)
- (5) Check that the AM depth indicated on the UUT is within  $\pm 5\%$  of reading  $\pm 1$  digit of the depth indicated on the external Modulation meter.
- (6) Repeat steps 4 and 5 for RF carrier frequencies of 500 MHz and 1050 MHz.
- (7) Refer to Results table 5-37 on page 5-48. On the UUT, select the 300 Hz low-pass filter and TX FREQ 100 MHz.
- (8) Set the external modulation monitor bandwidth to 30 Hz to 50 kHz.
- (9) Set the RF signal generator to provide a signal of 100 MHz with 70% depth at 50 Hz modulation rate. Check that the modulation depth indicated on the UUT is within  $\pm 8.5\%$  of reading  $\pm 1$  digit of the depth indicated on the Modulation meter.
- (10) On the UUT select the 50 kHz low-pass AF filter and the 300 kHz IF filter. Change the modulation rate on the RF signal generator to 10 kHz and check that the modulation depth indicated on the UUT is within  $\pm 8.5\%$  of reading  $\pm 1$  digit, of the depth indicated on the Modulation meter.
- (11) Refer to Results table 5-38 on page 5-49. When finished, select the 0.3 to 3.4 kHz filter on both the UUT and the external Modulation meter. Select the 30 kHz IF filter on the UUT.
- (12) Set the RF signal generator modulation rate to 1 kHz and set 5% AM depth.
- (13) Check that the AM depth indicated on the UUT is within  $\pm 5\%$  of reading  $\pm 1$  digit of the depth indicated on the Modulation meter. Repeat with the RF signal generator set to provide depths of 20%, 50%, 80%, and 95%.
- (14) Refer to Results table 5-39 on page 5-49. Select the Oscilloscope on the UUT. Set a timebase of 500  $\mu\text{s}/\text{div}$  and a vertical scale of 10%/div.
- (15) Set the RF signal generator to provide 60% AM, adjusting this level until the demodulated signal on the display occupies the full six divisions. Check that the modulation indicated on the external Modulation meter is 60%  $\pm 10\%$ .
- (16) Remove the splitter and Modulation meter and connect the RF signal generator directly to the UUT BNC input.
- (17) Refer to Results table 5-40 on page 5-49. Set the RF signal generator to provide a signal of 100 MHz at 6 dBm with 30% depth at 1 kHz modulation rate.
- (18) On the UUT, switch the oscilloscope off by selecting bar chart then select distortion measurement ON.
- (19) Check that the distortion reading on the UUT indicates less than 2%

## RF frequency meter

### Specification

<b>Frequency range:</b>	100 kHz to 1.05 GHz
<b>Resolution:</b>	0.1 Hz, 1 Hz or 10 Hz selectable
<b>Accuracy</b>	As frequency standard $\pm$ resolution
<b>Sensitivity autotuned</b>	5 mW (N-type), 0.05 mW (antenna port)
<b>Sensitivity manual tuned</b>	-34 dBm (N-type), -60 dBm (antenna port)

### Test equipment

Description	Minimum specification	Example
RF signal generator	100 kHz to 1.05 GHz	IFR 2965 or IFR 2041
RF power meter	$\pm 0.1$ dB from 10 MHz to 1 GHz	IFR 6960/A/B + 6920 sensor

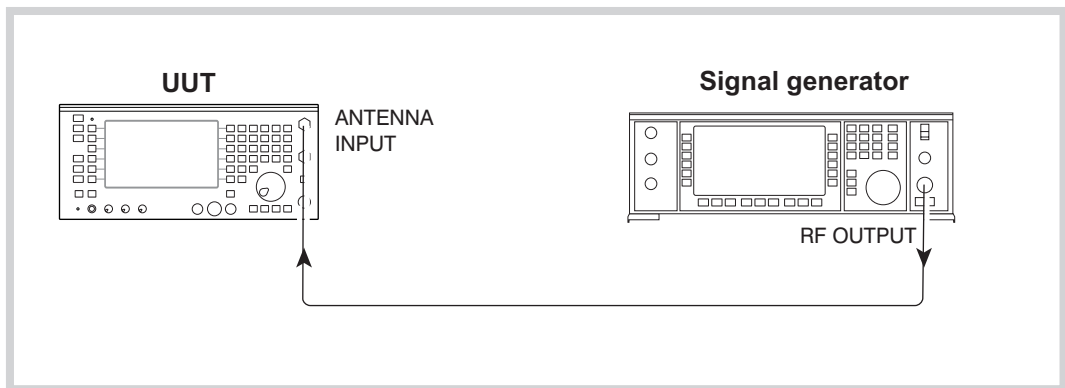

C6052

Fig. 5-17 RF frequency meter

- (1) Refer to Results table 5-41 on page 5-49. Connect the equipment as shown in Fig. 5-17, connecting the incoming signal to the antenna input socket of the UUT. Lock the Service Monitor external standard input to the external standard output of the signal generator.
- (2) Set the UUT to [Tx TEST], RF IN/OUT [SELECT] antenna BNC input socket. Press [HELP/SETUP], [Setup], and toggle RF counter resolution until 1 Hz is displayed in reverse field, then press [Return], [Return] to get back to the TX test display.
- (3) On the UUT, press [Tx Freq] 10 MHz. Set the RF signal generator to provide a signal of 10 MHz at an RF level of -60 dBm. Check this level by removing the RF test signal connection from the UUT and applying it to the RF power meter. Adjust the level if necessary, then reconnect the UUT.
- (4) Check that the offset indicated on the UUT is 0 Hz  $\pm$  1 Hz.
- (5) Repeat steps 3 & 4 for frequencies of 500 MHz and 1.05 GHz.
- (6) Refer to Results table 5-42 on page 5-50. Press the [Auto Tune] key on the UUT.
- (7) Set the RF signal generator to provide a signal of 1000 MHz at a level of -13 dBm (check and set this level on the power meter). Check that the UUT autotunes to the incoming frequency and the Frequency counter indicates the frequency  $\pm$  1 Hz. Repeat at 500 MHz and 10 MHz.
- (8) Disconnect the external reference from the UUT and connect an external reference with an accuracy of 1 part in  $10^9$  or better to the RF signal generator.



## ACCEPTANCE TESTING

---

- (9) *Refer to Results table 5-43 on page 5-50.* Set the RF signal generator to provide a frequency of 1000 MHz at a level of 0 dBm.
- (10) Check that the UUT indicates a frequency between 999.999500 MHz and 1000.000500 MHz. If the instrument is fitted with option 3, the high stability (OCXO) internal frequency standard, check that the reading falls between the limits 999.999750 and 1000.000250. The test limits in this step are for guidance and assume that the internal frequency standard has been recently adjusted. Ageing and stability have to be considered when establishing the *real* test limits.

## RF spectrum analyzer

### Specification

<b>Frequency range:</b>	100 kHz to 1.0 GHz.
<b>Resolution bandwidth</b>	300 Hz, 3, 30, 300 kHz, 3 MHz.
<b>Display dynamic range:</b>	80 dB.
Noise floor	Typically 75 dB below top of screen
<b>On screen linearity:</b>	Typically $\pm 2$ dB $\pm$ resolution (10 dB/div) (10 dB above the noise floor)
<b>Resolution:</b>	0.1 dB on 2 dB/ division 0.5 dB on 10 dB/ division
<b>Level flatness</b>	$\pm 1$ dB $\pm$ resolution over 50 MHz span.

### Test equipment

Description	Minimum specification	Example
RF signal generator	100 kHz to 1 GHz. Level accuracy $\pm 0.85$ dB	IFR 2041
RF power meter	$\pm 0.1$ dB from 10 MHz to 1 GHz	IFR 6960/A/B + 6912 sensor

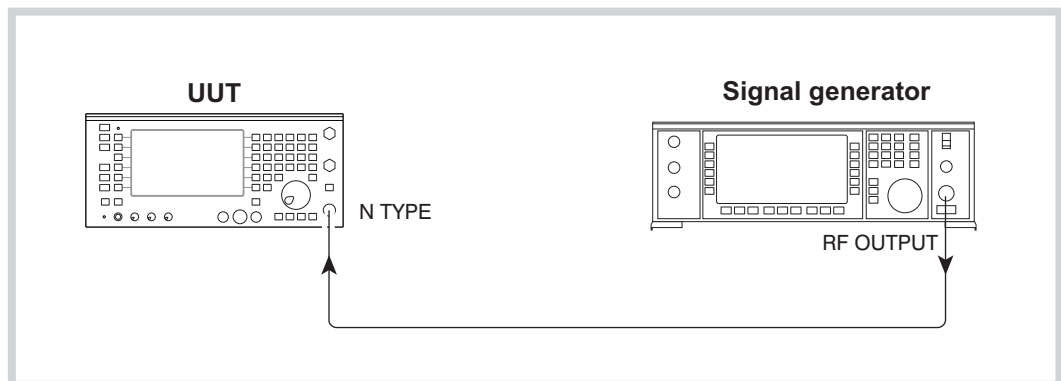

C6053

Fig. 5-18 RF spectrum analyzer checks

- (1) Refer to Results table 5-44 on page 5-50. Set the UUT to [SPEC ANA], Vid Filter ON, 10 dB/div, Res BW 300 Hz, and Peak Hold OFF, [Centre Freq] 101 MHz, [Span] 1 kHz, BNC antenna input socket, [Ref Level] -30.0 dBm.
- (2) With nothing connected to the UUT, check that the noise floor is within the bottom 10 dB graticule division of the display. (Between 70 and 80 dBm dynamic range.)
- (3) Connect the equipment as shown in Fig. 5-18, connecting the incoming signal to the N-type input socket of the UUT. Set the UUT to N-type input.
- (4) On the UUT, select [Res BW] [Manual Res BW], [30 kHz], [Ref Level] to 0 dBm.
- (5) Set the RF signal generator to provide a signal at 101 MHz at a level of 0 dBm with no modulation. Adjust the RF signal generator level until the trace sits at the top of the screen. Check that the level set on the RF signal generator is 0 dBm  $\pm$  4 dB (Functional test only). Note this reading (reading 1).
- (6) Reduce the RF signal generator RF level until the trace sits on the graticule line 1 division down from the top line. Check that the level set on the RF signal generator is 10 dB down from reading 1  $\pm$  3 dB (functional test only).

## ACCEPTANCE TESTING

---

- (7) Reduce the RF signal generator RF level until the trace sits on the graticule line 2 divisions down from the top line. Check that the level set on the RF signal generator is 20 dB down from reading  $1 \pm 3$  dB (functional test only).
- (8) Reduce the RF signal generator RF level until the trace sits on the graticule line 3 divisions down from the top line. Check that the level set on the RF signal generator is 30 dB down from reading  $1 \pm 3$  dB (functional test only).
- (9) Reduce the RF signal generator RF level until the trace sits on the graticule line 4 divisions down from the top line. Check that the level set on the RF signal generator is 40 dB down from reading  $1 \pm 3$  dB (functional test only).
- (10) Reduce the RF signal generator RF level until the trace sits on the graticule line 5 divisions down from the top line. Check that the level set on the RF signal generator is 50 dB down from reading  $1 \pm 3$  dB (functional test only).
- (11) On the UUT press *[Return]*, *[Return]*,*[Centre Freq]*, 100 MHz, *[Span]*, 52 MHz, *[Res BW]*, *[Manual Res BW]*, *[3 MHz]*, *[Vert Scale]* toggle *[10/2 dB/DIV]* until 2 dB per division is displayed.
- (12) Set the RF signal generator to 100 MHz and  $-6.0$  dBm. Check and set this level on the power meter and then connect to the UUT.
- (13) Make a note of how many divisions down from the top of screen that the peak of the signal appears.
- (14) Repeat steps 12 and 13 for RF signal generator frequencies of 75 MHz, 88 MHz, 112 MHz and 125 MHz.
- (15) Check that the difference between the highest and the lowest point noted is less than 1.1 divisions.
- (16) To functionally test the look/listen facility first set the following on the UUT. Select the *[Return]* , soft key at the bottom right hand corner of the display and then *[Return]* , *[Centre Freq]*, 300 MHz, *[Return]*, *[Vert Scale]*, toggle *[10/2DB /DIV]* until 10 dB per division is displayed, *[Span]*, 100 kHz, *[Res BW]*, *[Auto Res BW]*.
- (17) Set the RF signal generator to provide a signal of 300 MHz at a level of  $-10$  dBm. A signal should now appear at the center of the UUT display and be on or close to 1 division down from the top of the display.
- (18) On the UUT select look and listen mode by pressing the *[Return]* soft key at the bottom left hand corner of the display and then the *[Look n Listen]* soft key.
- (19) Check that the signal is still at the center of the display and on or close to 1 division down from the top of the display.
- (20) Set the RF signal generator to provide 10 kHz deviation at 1 kHz modulation rate on the 300 MHz signal.
- (21) Check that the UUT display now shows an FM modulated signal. Turn the front panel volume control up and check that a 1 kHz tone can be heard. This verifies the operation of the look/listen mode of the Spectrum analyzer. The tracking generator is in reality the instrument signal generator and is therefore tested when the signal generator is checked.

## RF broad band power meter

### Specification

<b>Frequency range:</b>	200 kHz to 1.05 GHz.
<b>Accuracy:</b>	± 10% ± resolution.
<b>Resolution:</b>	0.1 dB

### Test equipment

Description	Minimum specification	Example
Calibrated RF power source consisting of:-	Accuracy better than 2.1%..	See below.
RF signal generator	11 MHz to 1 GHz frequency range, RF level 13 dBm	IFR 2041
Power splitter	6 dB 50 Ω 11 MHz to 1 GHz.	Weinschel 1870A
RF Amplifier	3W 40 dB gain 11 MHz to 1000 MHz	IFR 2177 or AR5W1000 MHz
Attenuator pads	Values dependent upon amplifier used.	
RF power meter	±0.1 dB from 11 MHz to 1 GHz	IFR 6960/A/B + 6912 sensor

- (1) Refer to Results table 5-45 on page 5-51. Set the UUT to [Tx TEST], [SELECT] N-type input socket (i.e. only the ⊕ LED on). From power up, the instrument should already be set to Autotune mode with wide band power meter (WB) selected.
- (2) Connect the equipment as shown in Fig 5-19, connecting to the N-type input socket on the UUT.
- (3) Set the calibrated power source to provide a signal at 11 MHz and 100 mW(+20 dBm) to the UUT input. Note the level on the UUT broad band power meter and check that it is within the stated specification. Repeat at 100 MHz and then in 100 MHz steps up to and including 1000 MHz.

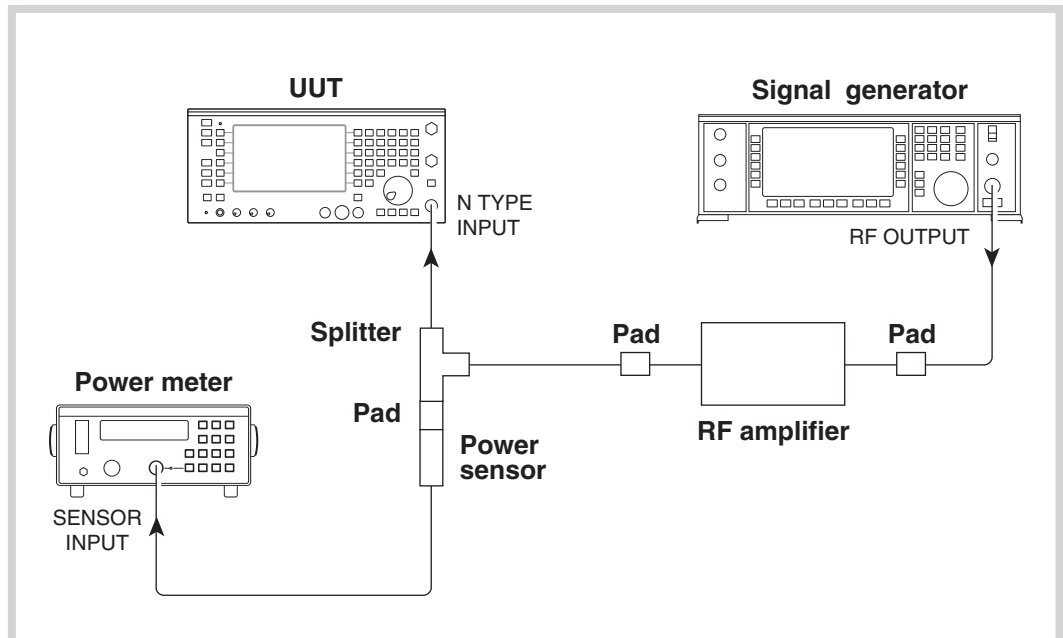

C6054

Fig. 5-19 RF broad band power meter checks

## ACCEPTANCE TESTING

---

- (1) Set the calibrated power source to provide 100 MHz and 100 mW. Press [SELECT] on the UUT to select N-type input/output, i.e. both LEDs above the N-type socket on. Note the level on the UUT broad band power meter and check that it is within the stated specification.
- (2) Set the calibrated power source to provide 5 mW(+7 dBm). Note the level on the UUT broad band power meter and check that it is within the stated specification.
- (3) Press [SELECT] on the UUT to select N-type input, i.e. only the  $\oplus$  LED on. Note the level on the UUT broad band power meter and check that it is within the stated specification.
- (4) Press [SELECT] on the UUT to select the antenna input socket and connect the calibrated power source to this. Note the level on the UUT broad band power meter and check that it is within 15% (functional check only).

<b>Notes</b>
--------------

- (1) **The power meter/sensor , splitter and two pads associated with these items form the calibrated part of the source.**
- (2) **The attenuator pad values are dependent upon the gain of the amplifier used. They should be chosen so that when the signal generator is set to its maximum output level the power arriving at the sensor is below +25 dBm i.e. not enough to damage the sensor.**
- (3) **If a calibrated power source is not available, the UUT power measurement can be functionally checked using an RF signal generator and power meter by checking the signal generator level before applying it to the UUT. It should be noted that no guarantees can be given of the mismatch uncertainties that may be introduced if this method is used.**

## Acceptance Test Results Tables

For 2944B, serial number \_\_\_\_\_ / \_\_\_\_\_

Results table 5-1 Carrier frequency accuracy

Frequency	Lower limit	Upper limit	Result
400.000 kHz	399.999	400.001	_____
1050.00000 MHz	1049.999999	1050.000001	_____
500.00000 MHz	499.999999	500.000001	_____
188.88888 MHz	188.888879	188.888881	_____
177.77777 MHz	177.777769	177.777771	_____
166.66666 MHz	166.666659	166.666661	_____
155.55555 MHz	155.555549	155.555551	_____
144.44444 MHz	144.444439	144.444441	_____
133.33333 MHz	133.333329	133.333331	_____
122.22222 MHz	122.222219	122.222221	_____
111.11111 MHz	111.111109	111.111111	_____

Results table 5-2 Signal generator level (-21 dBm) versus frequency (MHz)

Frequency	Lower limit (dBm)	Upper limit (dBm)	Result N-type out/ Antenna in	Result N-type out/ N-type in
10 MHz	-23	-19	_____	_____
100 MHz	-23	-19	_____	_____
200 MHz	-23	-19	_____	_____
300 MHz	-23	-19	_____	_____
400 MHz	-23	-19	_____	_____
500 MHz	-23	-19	_____	_____
600 MHz	-23	-19	_____	_____
700 MHz	-23	-19	_____	_____
800 MHz	-23	-19	_____	_____
900 MHz	-23	-19	_____	_____
1000 MHz	-23	-19	_____	_____

ACCEPTANCE TESTING

---

Results table 5-3 ALC linearity at 10 MHz

Level (dBm)	Lower limit	Upper limit	Result
-21	-23.0	-19.0	_____
-22	-24.0	-20.0	_____
-23	-25.0	-21.0	_____
-24	-26.0	-22.0	_____
-25	-27.0	-23.0	_____
-26	-28.0	-24.0	_____
-27	-29.0	-25.0	_____
-28	-30.0	-26.0	_____
-29	-31.0	-27.0	_____
-30	-32.0	-28.0	_____
-31	-33.0	-29.0	_____
-32	-34.0	-30.0	_____
-33	-35.0	-31.0	_____
-34	-36.0	-32.0	_____
-35	-37.0	-33.0	_____
-36	-38.0	-34.0	_____
-37	-39.0	-35.0	_____
-38	-40.0	-36.0	_____

**ACCEPTANCE TESTING**

---

**Results table 5-4 ALC linearity at 500 MHz**

<b>Level (dBm)</b>	<b>Lower limit</b>	<b>Upper limit</b>	<b>Result</b>
-21	-23.0	-19.0	_____
-22	-24.0	-20.0	_____
-23	-25.0	-21.0	_____
-24	-26.0	-22.0	_____
-25	-27.0	-23.0	_____
-26	-28.0	-24.0	_____
-27	-29.0	-25.0	_____
-28	-30.0	-26.0	_____
-29	-31.0	-27.0	_____
-30	-32.0	-28.0	_____
-31	-33.0	-29.0	_____
-32	-34.0	-30.0	_____
-33	-35.0	-31.0	_____
-34	-36.0	-32.0	_____
-35	-37.0	-33.0	_____
-36	-38.0	-34.0	_____
-37	-39.0	-35.0	_____
-38	-40.0	-36.0	_____

**Results table 5-5 ALC linearity at 1000 MHz**

<b>Level (dBm)</b>	<b>Lower limit</b>	<b>Upper limit</b>	<b>Result</b>
-21	-23.0	-19.0	_____
-22	-24.0	-20.0	_____
-23	-25.0	-21.0	_____
-24	-26.0	-22.0	_____
-25	-27.0	-23.0	_____
-26	-28.0	-24.0	_____
-27	-29.0	-25.0	_____
-28	-30.0	-26.0	_____
-29	-31.0	-27.0	_____
-30	-32.0	-28.0	_____
-31	-33.0	-29.0	_____
-32	-34.0	-30.0	_____
-33	-35.0	-31.0	_____
-34	-36.0	-32.0	_____
-35	-37.0	-33.0	_____
-36	-38.0	-34.0	_____
-37	-39.0	-35.0	_____
-38	-40.0	-36.0	_____



**ACCEPTANCE TESTING**

**Results table 5-6 Carrier harmonic test points at 0 dBm**

Frequency (MHz)	Second harmonic (MHz)	Result	Third harmonic (MHz)	Result	Upper limit (dBc)
0.4	0.8	_____	1.2	_____	-20
100.0	200.0	_____	300.0	_____	-20
300.0	600.0	_____	900.0	_____	-20
500.0	1000.0	_____	1500.0	_____	-20
700.0	1400.0	_____	2100.0	_____	-20
900.0	1800.0	_____	2700.0	_____	-20
1000.0	2000.0	_____	3000.0	_____	-20

**Results table 5-7 Spurious signals (carrier at 0 dBm)**

Carrier frequency (MHz)	Spurious measured	Upper limit (dBc)
0.4	_____	-40
500	_____	-40
1000	_____	-40
650	_____	-30

**Results table 5-8 RF carrier leakage (carrier at 501.9873 MHz)**

Carrier frequency (MHz)	Upper limit	Leakage detected
501.9873	0.5 $\mu$ V PD	_____

**Results table 5-9 Residual FM test points**

UUT RF generator frequency (MHz)	Local oscillator frequency (MHz)	Limits (Hz)	Result
1000	55.63889	20	_____
400	50.18750	15	_____
100	50.75000	15	_____

**ACCEPTANCE TESTING**

**Results table 5-10 AM versus carrier frequency (50% depth at 1 kHz rate)**

Carrier frequency (MHz)	Lower limit (%)	Upper limit (%)	Result (%)
1.5	45.5	54.5	_____
50	45.5	54.5	_____
100	45.5	54.5	_____
150	45.5	54.5	_____
200	45.5	54.5	_____
250	45.5	54.5	_____
300	45.5	54.5	_____
350	45.5	54.5	_____
400	45.5	54.5	_____

**Results table 5-11 AM versus carrier level (100 MHz, 70% depth at 1 kHz rate)**

Carrier level (dBm)	Lower limit (%)	Upper limit (%)	Result (%)
5	64.1	75.9	_____
4	64.1	75.9	_____
3	64.1	75.9	_____
2	64.1	75.9	_____
1	64.1	75.9	_____
0	64.1	75.9	_____
-1	64.1	75.9	_____
-2	64.1	75.9	_____
-3	64.1	75.9	_____
-4	64.1	75.9	_____
-5	64.1	75.9	_____
-6	64.1	75.9	_____
-7	64.1	75.9	_____
-8	64.1	75.9	_____
-9	64.1	75.9	_____
-10	64.1	75.9	_____
-11	64.1	75.9	_____
-12	64.1	75.9	_____
-13	64.1	75.9	_____
-14	64.1	75.9	_____
-15	64.1	75.9	_____

**ACCEPTANCE TESTING**

---

**Results table 5-12 AM linearity (100 MHz, 0 dBm at 1 kHz rate)**

<b>Am depth set (%)</b>	<b>Lower limit (%)</b>	<b>Upper limit (%)</b>	<b>Result (%)</b>
5	3.65	6.35	_____
10	8.3	11.7	_____
20	17.6	22.4	_____
30	26.9	33.1	_____
40	36.2	43.8	_____
50	45.5	54.5	_____
60	54.8	65.2	_____
70	64.1	75.9	_____
85	79.1	91.95	_____

**Results table 5-13 AM versus modulation frequency (100 MHz, 85% depth)**

<b>AM frequency (kHz)</b>	<b>Lower limit (%)</b>	<b>Upper limit (%)</b>	<b>Result (%)</b>
0.065	75.5	94.5	_____
0.140	75.5	94.5	_____
0.500	75.5	94.5	_____
2	75.5	94.5	_____
5	75.5	94.5	_____
15	71.25	98.75	_____

**Results table 5-14 AM demodulation distortion (100 MHz, 30% depth)**

<b>Distortion upper limit (%)</b>	<b>Result (%)</b>
2	_____

**ACCEPTANCE TESTING**

**Results table 5-15 FM versus carrier frequency (at 10 kHz deviation 1 kHz rate)**

Carrier frequency (MHz)	Lower limit (kHz)	Upper limit (kHz)	Result
0.5	9.490	10.510	_____
10	9.490	10.510	_____
100	9.490	10.510	_____
200	9.490	10.510	_____
300	9.490	10.510	_____
400	9.490	10.510	_____
500	9.490	10.510	_____
600	9.490	10.510	_____
700	9.490	10.510	_____
800	9.490	10.510	_____
900	9.490	10.510	_____
925	9.490	10.510	_____
975	9.490	10.510	_____
1050	9.490	10.510	_____

**Results table 5-16 FM linearity checks (at 600 MHz carrier frequency 1 kHz rate)**

Deviation frequency (kHz)	Lower limit (kHz)	Upper limit (kHz)	Result
75	71.24	78.76	_____
50	47.49	52.51	_____
25	23.74	26.26	_____
5	4.74	5.26	_____

**Results table 5-17 FM distortion**

Modulation frequency (kHz)	Distortion upper limit (%)	Result
1	1	_____

**Results table 5-18 FM versus modulation frequency (at 600 MHz carrier frequency, 10 kHz deviation)**

Modulation frequency	Lower limit (kHz)	Upper limit (kHz)	Result
50 Hz	8.99	11.01	_____
10 kHz	8.99	11.01	_____
15 kHz	8.99	11.01	_____

**ACCEPTANCE TESTING**

**Results table 5-19 Audio generator 1 output level**

<b>AF generator 1 frequency (Hz)</b>	<b>Level (mV)</b>	<b>Lower limit (mV)</b>	<b>Upper limit (mV)</b>	<b>Result</b>
1000	4000	3799	4201	_____
50	4000	3799	4201	_____
150	4000	3799	4201	_____
500	4000	3799	4201	_____
2000	4000	3799	4201	_____
5000	4000	3799	4201	_____
10000	4000	3799	4201	_____
15000	4000	3799	4201	_____
1000	20.0	18.9	21.1	_____
1000	400.0	379.9	420.1	_____
1000	1000	949	1051	_____
1000	2000	1899	2101	_____
1000	3000	2849	3151	_____

**Results table 5-20 Audio generator 2 output level**

<b>AF generator 2 frequency (Hz)</b>	<b>Level (mV)</b>	<b>Lower limit (mV)</b>	<b>Upper limit (mV)</b>	<b>Result</b>
1000	4000	3799	4201	_____
50	4000	3799	4201	_____
150	4000	3799	4201	_____
500	4000	3799	4201	_____
2000	4000	3799	4201	_____
5000	4000	3799	4201	_____
10000	4000	3799	4201	_____
15000	4000	3799	4201	_____
1000	20.0	18.9	21.1	_____
1000	400.0	379.9	420.1	_____
1000	1000	949	1051	_____
1000	2000	1899	2101	_____
1000	3000	2849	3151	_____

**ACCEPTANCE TESTING**

---

**Results table 5-21 Audio generator 1 distortion**

AF generator 1 frequency (Hz)	Level (mV)	Distortion upper limit (%)	Result
1000	4000	0.5	_____
1000	100.0	0.5	_____
2000	4000	1.0	_____
5000	4000	1.0	_____
15000	4000	1.0	_____

**Results table 5-22 Audio generator 2 distortion**

AF generator 2 frequency (Hz)	Level (mV)	Distortion upper limit (%)	Result
1000	4000	0.5	_____
1000	100.0	0.5	_____
2000	4000	1.0	_____
5000	4000	1.0	_____
15000	4000	1.0	_____

**Results table 5-23 Audio generator 1 frequency (functional)**

AF generator 1 setting	Lower limit	Upper limit	Result
10 Hz	9.9 Hz	10.1 Hz	_____
500 Hz	499.9 Hz	500.1 Hz	_____
1.0000 kHz	999.9 Hz	1000.1 Hz	_____
1.1111 kHz	1.1110 kHz	1.1112 kHz	_____
2.2222 kHz	2.2221 kHz	2.2223 kHz	_____
3.333 kHz	3.3328 kHz	3.3332 kHz	_____
4.444 kHz	4.4438 kHz	4.4442 kHz	_____
5.555 kHz	5.5548 kHz	5.5552 kHz	_____
6.666 kHz	6.6658 kHz	6.6662 kHz	_____
7.777 kHz	7.7768 kHz	7.7772 kHz	_____
8.888 kHz	8.8878 kHz	8.8882 kHz	_____
9.999 kHz	9.9988 kHz	10.0010 kHz	_____
15.000 kHz	14.999 kHz	15.0010 kHz	_____
20.000 kHz	19.9989 kHz	20.0011 kHz	_____

**ACCEPTANCE TESTING**

---

**Results table 5-24 Audio generator 2 frequency (functional)**

<b>AF generator 2 setting</b>	<b>Lower limit</b>	<b>Upper limit</b>	<b>Result</b>
10 Hz	9.9 Hz	10.1 Hz	_____
500 Hz	499.9 Hz	500.1 Hz	_____
1.0000 kHz	999.9 Hz	1000.1 Hz	_____
1.1111 kHz	1.1110 kHz	1.1112 kHz	_____
2.2222 kHz	2.2221 kHz	2.2223 kHz	_____
3.333 kHz	3.3328 kHz	3.3332 kHz	_____
4.444 kHz	4.4438 kHz	4.4442 kHz	_____
5.555 kHz	5.5548 kHz	5.5552 kHz	_____
6.666 kHz	6.6658 kHz	6.6662 kHz	_____
7.777 kHz	7.7768 kHz	7.7772 kHz	_____
8.888 kHz	8.8878 kHz	8.8882 kHz	_____
9.999 kHz	9.9988 kHz	10.0010 kHz	_____
15.000 kHz	14.999 kHz	15.0010 kHz	_____
20.000 kHz	19.9989 kHz	20.0011 kHz	_____

**Results table 5-25 Audio frequency meter**

<b>LF generator frequency</b>	<b>Level (mV)</b>	<b>Lower limit</b>	<b>Upper limit</b>	<b>Result</b>
20 Hz	50	19.8 Hz	20.2 Hz	_____
1 kHz	50	999.8 Hz	1000.2 Hz	_____
20 kHz	50	19.9989 kHz	20.0011 kHz	_____

**ACCEPTANCE TESTING**

**Results table 5-26 Audio voltmeter accuracy**

Frequency	DVM reading (mV)	UUT coupling	UUT lower limit* (mV) ‡	UUT upper limit* (mV) †	Result
1 kHz	30	AC	25.1	34.9	_____
1 kHz	200	AC	189	211	_____
1 kHz	400	AC	381	419	_____
1 kHz	800	AC	765	835	_____
1 kHz	2000	AC	1917	2083	_____
1 kHz	4500	AC	3317	4683	_____
50 Hz	1000	AC	957	1043	_____
100 Hz	1000	AC	957	1043	_____
500 Hz	1000	AC	957	1043	_____
10 kHz	1000	AC	957	1043	_____
30 kHz	1000	AC	957	1043	_____
50 kHz	1000	AC	957	1043	_____
DC	25000	DC	23997	26003	_____
DC	50000	DC	47997	52003	_____

† The upper and lower limits in the above table are calculated on the assumption that it was possible to set the exact level. If it is not possible to achieve this, the limits will need to be calculated for the DVM reading obtained.

**Results table 5-27 Oscilloscope accuracy**

LF generator level (mV RMS)	UUT (Volts/div)	DVM lower limit	DVM upper limit	Result
21.2	10 mV/div	20.15	22.27	_____
42.4	20 mV/div	40.3	44.54	_____
106	50 mV/div	100.7	111.4	_____
212	100 mV/div	201.5	222.7	_____
424	200 mV/div	403.0	445.4	_____
1061	500 mV/div	1007.5	1113.5	_____
2121	1 V/div	2.015	2.227	_____
4242	2 V/div	4.030	4.454	_____
<b>DC supply</b>				
20 V	5 V/div	18.5 V	21.5 V	_____
20 V	10 V/div	17 V	23 V	_____
20 V	20 V/div	14 V	26 V	_____



**ACCEPTANCE TESTING**

**Results table 5-28 Oscilloscope**

LF generator frequency	UUT timebase	DVM lower limit	DVM upper limit	Result
10 Hz	50 ms/div	2.015 V	2.227 V	_____
10 kHz	50 μs/div	2.015 V	2.227 V	_____
20 kHz	50 μs/div	2.015 V	2.227 V	_____

**Results table 5-29 Distortion & SINAD meter**

Distortion/SINAD set	Lower limit	Upper limit	Result
2%	1.4%	2.6 %	_____
25%	23.2%	26.8 %	_____
12 dB	11.0 dB	13.0 dB	_____

**Results table 5-30 FM measurement versus carrier frequency (1 kHz rate)**

Carrier frequency (MHz)	Deviation (kHz)	IF filter (kHz)	AF filter	Lower limit (kHz) †	Upper limit (kHz) †	Result
5.5	20	30	0.3 to 3.4	18.8	21.2	_____
500	20	30	0.3 to 3.4	18.8	21.2	_____
1000	20	30	0.3 to 3.4	18.8	21.2	_____

**Results table 5-31 FM measurement versus modulation rate**

Modulation rate	AF filter	Deviation (kHz)	Lower limit (kHz) †	Upper limit (kHz) †	Result
50 Hz	300 Hz LP	20	18.4	21.6	_____
5 kHz	15 kHz LP	20	18.4	21.6	_____
10 kHz	50 kHz LP	20	18.4	21.6	_____

**Results table 5-32 FM measurement versus deviation level (1 kHz rate)**

Deviation level	IF bandwidth	Lower limit (kHz) †	Upper limit (kHz) †	Result
250 Hz ‡	3 kHz	0.200	0.2725	_____
10 kHz	30 kHz	9.4	10.6	_____
50 kHz	300 kHz	47	53	_____
75 kHz	300 kHz	70.5	79.5	_____

† The upper and lower limits in Results table 5-30, Results table 5-31, and Results table 5-32 are calculated on the assumption that it was possible to set the exact level on the external Modulation meter. If it is not possible to achieve this, the limits will need to be calculated for the readings obtained.

‡ For the lower deviation in Results table 5-32, subtract the residual FM reading from the measured result.

**ACCEPTANCE TESTING**

**Results table 5-33 FM demodulation oscilloscope**

Carrier frequency (MHz)	Deviation (kHz)	Lower limit (kHz)	Upper limit (kHz)	Result
300	75	67.5	82.5	_____

**Results table 5-34 FM demodulation output socket**

Carrier frequency (MHz)	Deviation (kHz)	Lower limit	Upper limit	Result
300	75	4.77 V	5.83 V	_____

**Results table 5-35 FM demodulation distortion (1 kHz rate)**

Carrier frequency (MHz)	Deviation (kHz)	Upper limit	Result
300	5	2%	_____

**Results table 5-36 AM measurement versus carrier frequency (1 kHz rate)**

Carrier frequency (MHz)	Depth (%)	Lower limit (%) †	Upper limit (%) †	Result
0.5	70	65.5	74.5	_____
500	70	65.5	74.5	_____
1050	70	65.5	74.5	_____

**Results table 5-37 AM measurement versus modulation rate**

Modulation rate	Depth (%)	Lower limit (%) †	Upper limit (%) †	Result
50 Hz	70	63	77	_____
10 kHz	70	63	77	_____

**ACCEPTANCE TESTING**

**Results table 5-38 AM measurement versus AM depth (1 kHz rate)**

Depth (%)	Lower limit (%) †	Upper limit (%) †	Result
5	3.75	6.25	_____
20	18	22	_____
50	46.5	53.5	_____
80	75	85	_____
95	89	100	_____

**Results table 5-39 AM demodulation oscilloscope**

Carrier frequency (MHz)	Depth (%)	Lower limit (%) †	Upper limit (%) †	Result
100	60	54	66	_____

† The upper and lower limits in Results table 5-36, Results table 5-37, Results table 5-38, and Results table 5-39 are calculated on the assumption that it was possible to set the exact level on the external Modulation meter. If it is not possible to achieve this, the limits will need to be calculated for the DVM readings obtained.

**Results table 5-40 AM demodulation distortion (1 kHz rate)**

Carrier frequency (MHz)	Depth (%)	Upper limit (%)	Result
100	30	2	_____

**Results table 5-41 RF frequency meter (at -60 dBm antenna input, manual tuned)**

Carrier frequency (MHz)	Offset lower limit (Hz)	Offset upper limit (Hz)	Result
10	-1	1	_____
500	-1	1	_____
1050	-1	1	_____

**ACCEPTANCE TESTING**

---

**Results table 5-42 RF frequency meter (at -13 dBm (0.05 mW) antenna input autotuned)**

Carrier frequency (MHz)	Lower limit (MHz)	Upper limit (MHz)	Result
1000	999.999999	1000.000001	_____
500	499.999999	500.000001	_____
10	9.999999	10.000001	_____

**Results table 5-43 Internal frequency standard**

Carrier frequency (MHz)	Lower limit (MHz)	Upper limit (MHz)	Result
<b>Standard (TCXO)</b> 1000	999.999500	100.000500	_____
<b>Option 3 (OCXO)</b> 1000	999.999750	100.000250	_____

**Results table 5-44 Spectrum analyzer**

Parameter	Limits	Result
Dynamic range	≥70 dB	_____
Level flatness	2.2 dB	_____

**ACCEPTANCE TESTING**

**Results table 5-45 RF broad band power meter (N-type input)**

Frequency (MHz)	Input level (dBm)	Lower limit (dBm)	Upper limit (dBm)	Result
<b>N-input</b>				
11	20	19.4	20.5	_____
100	20	19.4	20.5	_____
200	20	19.4	20.5	_____
300	20	19.4	20.5	_____
400	20	19.4	20.5	_____
500	20	19.4	20.5	_____
600	20	19.4	20.5	_____
700	20	19.4	20.5	_____
800	20	19.4	20.5	_____
900	20	19.4	20.5	_____
1000	20	19.4	20.5	_____
<b>N in / N out</b>				
100	20	19.4	20.5	_____
100	7	6.4	7.5	_____
<b>N input</b>				
100	7	6.4	7.5	_____

The upper and lower limits in the table above are calculated on the assumption that it was possible to set the exact input level required. If it is not possible to achieve this, the limits will need to be calculated in proportion to the power applied.

---

# Index

## A

AC power supply input ..... 3-8  
AC supply ..... 4-2  
Acceptance test results tables ..... 5-36  
Acceptance testing ..... 5-1  
Acceptance tests ..... 5-3  
Accessory connector, front panel ..... 3-6  
Accessory port, rear optional ..... 3-94  
Accessory socket connections ..... 2-7  
Accessory socket logic ..... 2-8  
AF GEN OUT, connector ..... 3-6  
AF input coupling option ..... 3-7  
AF measuring circuits ..... 4-14  
AF TEST mode ..... 3-63  
AF testing ..... 1-6  
Airflow ..... 2-2  
Antenna input ..... 4-9  
Attenuator, switched ..... 4-10  
Attenuators, external ..... 3-33  
Audio distortion measurement, Rx test ..... 3-65  
Audio generator set-up ..... 3-30  
Audio generators ..... 4-7, 4-14  
Audio level ..... 3-17  
Autotune ..... 3-25, 3-26

## B

Bandwidth filters ..... 4-11  
Battery pack, endurance ..... 2-6  
Battery pack, recharge ..... 2-6  
Block diagram ..... 4-2  
Bridge rectifier ..... 4-3  
Broadband power meter ..... 4-9

## C

Connections, DC supply ..... 2-6  
Connections, remote control ..... 2-9  
Connections, RF and AF ..... 2-6  
Connections, RS232 ..... 2-9  
Connectors, rear panel ..... 3-8  
Connectors, RF input and output ..... 3-5  
Controls, rear panel ..... 3-8  
Conventions for key labelling ..... ii  
Cooling fan ..... 3-9

## D

Data generator ..... 4-8  
DC supply ..... 4-2  
DC supply input ..... 3-8  
DC supply, external ..... 4-3  
De-emphasis filter ..... 4-12  
Demodulated signal output ..... 3-8  
Demodulation options set-up ..... 3-27  
Demodulation settings, look and listen ..... 3-61  
Demodulator, AM ..... 4-11  
Demodulator, FM ..... 4-11  
Disconnecting device ..... 2-4

Display ..... 4-3  
Display hold ..... 3-7  
Display screen ..... 3-4  
Distortion measurement, transmitter audio ..... 3-29  
Distortion/SINAD filter ..... 4-13  
DUPLEX ..... 3-22  
Duplex testing ..... 1-5, 3-53  
Dx TEST mode ..... 4-15

## E

Electrical Hazards ..... v  
External attenuators ..... 3-33  
*External attenuators, RF power* ..... 3-41

## F

Facilities ..... 1-2  
Filter, distortion/SINAD ..... 4-13  
Filters, fan ..... 2-2  
Fire Hazards ..... v  
Fitting batteries ..... 2-6  
Frequency changer/mixer, first ..... 4-10  
Frequency changer/mixer, second ..... 4-10  
Frequency changer/mixer, third ..... 4-11  
Frequency setting, automatic ..... 3-26  
Frequency standard, external ..... 3-8  
Front panel layout ..... 3-4  
Fuses ..... 2-3

## G

General information ..... 1-1  
Getting started ..... 3-9  
GPIB address ..... 3-13  
GPIB connections ..... 2-10  
GPIB remote control ..... 1-2

## H

Hard copy ..... 3-93  
Hold display ..... 3-7

## I

IF circuits ..... 4-10  
Incremental adjustments ..... 3-67  
Incremental adjustments, spectrum analyzer ..... 3-68  
Incremental keys, duplex test mode ..... 3-6  
Incremental keys, spectrum analyzer mode ..... 3-6  
Input power, maximum ..... 3-25  
Input switching ..... 4-9  
Input/output switching board ..... 4-9  
Installation ..... 2-1

## K

Key AF input coupling ..... 3-7  
Key, HELP/SETUP ..... 3-7  
Key, SELECT, RF input ..... 3-6  
Keys, blue ..... 3-7, 3-10  
Keys, data input ..... 3-5  
Keys, function ..... 3-5

Keys, increment adjustment .....	3-6
keys, orange.....	3-5
Keys, orange.....	3-5
Keys, oscilloscope sweep mode .....	3-7
Keys, soft.....	3-5
keys, terminator .....	3-5
Keys, test mode .....	3-10
Keys, test mode select .....	3-7

## L

Lithium batteries.....	v
Local operation, returning to .....	3-7
Local oscillator, first.....	4-10
Local oscillator, second .....	4-11
Logic lines, setting up.....	3-95
Look and listen .....	3-60
Look and Listen.....	1-6, 3-19
Look And Listen function .....	4-15
Loudspeaker .....	4-15

## M

Memories, settings/results .....	3-90
Memories, set-up/results.....	3-25
Menus, test modes .....	3-10
Microphone, 'press to talk'.....	3-25
Modulation control .....	4-14
Modulation distortion .....	3-36
Modulation input, external .....	3-8
Modulation sources .....	3-41
Modulation Sources.....	4-7
Modulators.....	4-14

## N

N Type connector .....	4-9
Naming conventions .....	ii

## O

Oscilloscope .....	3-19
Oscilloscope display .....	4-13
Oscilloscope, using.....	3-88
Overload detection.....	4-10
Overload warning message.....	4-10

## P

Parallel printer port option, using .....	3-93
Positioning for use .....	2-12
Power attenuator, 20dB .....	4-9
Power consumption .....	2-3
Power overload.....	3-32
Power requirements .....	2-3
Power switch .....	3-8
Power, excessive.....	4-10
Pre-emphasis filter.....	4-14
Preparing, for use .....	2-2
Printer .....	3-93

## R

Ranging circuits, measurements .....	4-12
Receiver circuits .....	4-9

Receiver test measurements .....	3-47
Receiver testing.....	1-4, 3-38
Reference level, spectrum analyzer.....	3-6
Remote control connections .....	2-9
Results tables acceptance tests .....	5-36
RF amplifier .....	4-14
RF counter.....	4-12
RF generator.....	4-13
RF input attenuators, tones mode.....	3-70
RF level .....	3-16
<i>RF power external atten</i> .....	3-41
RIC .....	3-86, 3-87
Routine maintenance .....	2-13
RS232 control.....	1-2
Rx frequency setting .....	3-40
Rx TEST mode.....	4-13

## S

Safety testing (routine) .....	2-14
Self tests .....	2-11
Setup.....	3-11
Setup menu pages.....	3-11
Signal routing, tones mode.....	3-70
spectrum analyzer.....	1-3
Spectrum analyzer .....	1-6, 3-19, 3-55
Mode .....	4-15
Setting up .....	3-56
Span adjustment .....	3-6
SSB input sensitivity .....	3-27
SSB transmitter frequency .....	3-34
Stores, settings/results .....	3-90
Supply, 36 V .....	4-3

## T

Technical description .....	4-1
Terminator keys.....	3-5
Test capabilities.....	1-2
Test equipment for Acceptance tests.....	5-4
Test mode screens .....	3-10
Test modes, using .....	3-21
Testing, AF mode.....	3-63
Tilt warning.....	vii
Tones .....	3-22
CTCSS .....	3-76
DCS.....	3-78
DTMF .....	3-81
POCSAG.....	3-85
Sequential.....	3-71
Tones mode .....	3-69
Tones mode RF input attenuators.....	3-70
Tones mode signal routing .....	3-70
Tracking generator .....	1-6
Tracking generator, spectrum analyzer .....	3-59
Transmitter power measurement .....	3-32
Transmitter test measurements .....	3-32
Transmitter testing.....	1-3, 3-23
Tx power measurement .....	3-27
Tx TEST mode.....	4-7

---

**V**  
Ventilation .....2-2  
Ventilation fan and filter .....2-13

Visual inspection, new instruments ..... 2-2  
**W**  
Warning, audible and visual..... 3-32



---

# AEROFLEX INTERNATIONAL LTD. SOFTWARE LICENCE AND WARRANTY

This document is an Agreement between the user of this Licensed Software, the Licensee, and Aeroflex International Limited, the Licensor. By opening this Software package or commencing to use the software you accept the terms of this Agreement. If you do not agree to the terms of this Agreement please return the Software package unopened to Aeroflex International Limited or do not use the software.

## 1. DEFINITIONS

The following expressions will have the meanings set out below for the purposes of this Agreement:

Add-In Application Software	Licensed Software that may be loaded separately from time to time into the Equipment to improve or modify its functionality
Computer Application Software	Licensed Software supplied to run on a standard PC or workstation
Designated Equipment	the single piece of Equipment upon which the licensed software is installed
Downloaded Software	any software downloaded from an Aeroflex web site
Embedded Software	Licensed Software that forms part of the Equipment supplied by Aeroflex and without which the Equipment cannot function
Licence Fee	the consideration ruling at the date of this Agreement for the use of one copy of the Licensed Software on the Designated Equipment
Licensed Software	All and any programs, listings, flow charts and instructions in whole or in part including Add-in, Computer Application, Downloaded and Embedded Software supplied to work with Designated Equipment

## 2. LICENCE FEE

The Licensee shall pay the Licence Fee to Aeroflex in accordance with the terms of the contract between the Licensee and Aeroflex.

## 3. TERM

This Agreement shall be effective from the date hereof and shall continue in force until terminated under the provisions of Clause 9.

## 4. LICENCE

- 4.1 Unless and until terminated, this Licence confers upon the Licensee the non-transferable and non-exclusive right to use the Licensed Software on the Designated Equipment.
- 4.2 The Licensee may not use the Licensed Software on other than the Designated Equipment, unless written permission is first obtained from Aeroflex and until the appropriate additional Licence Fee has been paid to Aeroflex.
- 4.3 The Licensee may not amend or alter the Licensed Software and shall have no right or licence other than that stipulated herein.
- 4.4 The Licensee may make not more than two copies of the Licensed Software (but not the Authoring and Language Manuals) in machine-readable form for operational security and shall ensure that all such copies include Aeroflex's copyright notice, together with any features which disclose the name of the Licensed Software and the Licensee. Furthermore, the Licensee shall not permit the Licensed Software or any part to be disclosed in any form to any third party and shall maintain the Licensed Software in secure premises to prevent any unauthorised disclosure. The Licensee shall notify Aeroflex immediately if the Licensee has knowledge that any unlicensed party possesses the Licensed Software. The Licensee's obligation to maintain confidentiality shall cease when the Licensed Software and all copies have been destroyed or returned. The copyright in the Licensed Software shall remain with Aeroflex. The Licensee will permit Aeroflex at all reasonable times to audit the use of the Licensed Software.
- 4.5 The Licensee will not disassemble or reverse engineer the Licensed Software, nor sub-licence, lease, rent or part with possession or otherwise transfer the whole or any part of the Licensed Software.

## 5. WARRANTY

- 5.1 Aeroflex certifies that the Licensed Software supplied by Aeroflex will at the time of delivery function substantially in accordance with the applicable Software Product Descriptions, Data Sheets or Product Specifications published by Aeroflex.
  - 5.2 The warranty period (unless an extended warranty for Embedded Software has been purchased) from date of delivery in respect of each type of Licensed Software is:

Embedded Software	12 months
Add-In Application Software	90 days
Computer Application Software	90 days
Downloaded Software	No warranty
  - 5.3 If during the appropriate Warranty Period the Licensed Software does not conform substantially to the Software Product Descriptions, Data Sheets or Product Specifications Aeroflex will provide:
    - 5.3.1 In the case of Embedded Software and at Aeroflex's discretion either a fix for the problem or an effective and efficient work-around.
    - 5.3.2 In the case of Add-In Application Software and Computer Application Software and at Aeroflex's discretion replacement of the software or a fix for the problem or an effective and efficient work-around.
  - 5.4 Aeroflex does not warrant that the operation of any software will be uninterrupted or error free.
-

6 The above Warranty does not apply to:

- 6.1 Defects resulting from software not supplied by Aeroflex, from unauthorised modification or misuse or from operation outside of the specification.
- 6.2 Third party produced Proprietary Software which Aeroflex may deliver with its products, in such case the third party Software Licence Agreement including its warranty terms shall apply.
- 7 The remedies offered above are sole and exclusive remedies and to the extent permitted by applicable law are in lieu of any implied conditions, guarantees or warranties whatsoever and whether statutory or otherwise as to the software all of which are hereby expressly excluded.

#### **8. INDEMNITY**

- 8.1 Aeroflex shall defend, at its expense, any action brought against the Licensee alleging that the Licensed Software infringes any patent, registered design, trademark or copyright, and shall pay all Licensor's costs and damages finally awarded up to an aggregate equivalent to the Licence fee provided the Licensee shall not have done or permitted to be done anything which may have been or become any such infringement and shall have exercised reasonable care in protecting the same failing which the Licensee shall indemnify Aeroflex against all claims costs and damages incurred and that Aeroflex is given prompt written notice of such claim and given information, reasonable assistance and sole authority to defend or settle such claim on behalf of the Licensee. In the defence or settlement of any such claim, Aeroflex may obtain for the Licensee the right to continue using the Licensed Software or replace it or modify it so that it becomes non-infringing.
- 8.2 Aeroflex shall not be liable if the alleged infringement:
  - 8.2.1 is based upon the use of the Licensed Software in combination with other software not furnished by Aeroflex, or
  - 8.2.2 is based upon the use of the Licensed Software alone or in combination with other software in equipment not functionally identical to the Designated Equipment, or
  - 8.2.3 arises as a result of Aeroflex having followed a properly authorised design or instruction of the Licensee, or
  - 8.2.4 arises out of the use of the Licensed Software in a country other than the one disclosed to Aeroflex as the intended country of use of the Licensed Software at the commencement of this Agreement.
- 8.3 Aeroflex shall not be liable to the Licensee for any loss of use or for loss of profits or of contracts arising directly or indirectly out of any such infringement of patent, registered design, trademark or copyright.

#### **9. TERMINATION**

- 9.1 Notwithstanding anything herein to the contrary, this Licence shall forthwith determine if the Licensee:
  - 9.1.1 As an individual has a Receiving Order made against him or is adjudicated bankrupt or compounds with creditors or as a corporate body, compounds with creditors or has a winding-up order made against it or
  - 9.1.2 Parts with possession of the Designated Equipment.
- 9.2 This Licence may be terminated by notice in writing to the Licensee if the Licensee shall be in breach of any of its obligations hereunder and continue in such breach for a period of 21 days after notice thereof has been served on the Licensee.
- 9.3 On termination of this Agreement for any reason, Aeroflex may require the Licensee to return to Aeroflex all copies of the Licensed Software in the custody of the Licensee and the Licensee shall, at its own cost and expense, comply with such requirement within 14 days and shall, at the same time, certify to Aeroflex in writing that all copies of the Licensed Software in whatever form have been obliterated from the Designated Equipment.

#### **10. THIRD PARTY LICENCES**

The software or part thereof may be the proprietary property of third party licensors. In such an event such third party licensors (as referenced on the package or the Order Acknowledgement) and/or Aeroflex may directly enforce the terms of this Agreement and may terminate the Agreement if the Licensee is in breach of the conditions contained herein.

#### **11. EXPORT REGULATIONS**

The Licensee undertakes that where necessary the Licensee will conform with all relevant export regulations imposed by the Governments of the United Kingdom and/or the United State of America.

#### **12. NOTICES**

Any notice to be given by the Licensee to Aeroflex shall be addressed to:

Aeroflex International Limited, Longacres House, Six Hills Way, Stevenage, SG1 2AN, UK.

#### **13. LAW AND JURISDICTION**

This Agreement shall be governed by the laws of England and shall be subject to the exclusive jurisdiction of the English courts. This agreement constitutes the whole Contract between the parties and may be changed only by memorandum signed by both parties.

© AEROFLEX INTERNATIONAL LTD 2004

**CHINA Beijing**

Tel: [+86] (10) 6539 1166  
Fax: [+86] (10) 6539 1778

**CHINA Shanghai**

Tel: [+86] (21) 5109 5128  
Fax: [+86] (21) 5150 6112

**FINLAND**

Tel: [+358] (9) 2709 5541  
Fax: [+358] (9) 804 2441

**FRANCE**

Tel: [+33] 1 60 79 96 00  
Fax: [+33] 1 60 77 69 22

**GERMANY**

Tel: [+49] 8131 2926-0  
Fax: [+49] 8131 2926-130

**HONG KONG**

Tel: [+852] 2832 7988  
Fax: [+852] 2834 5364

**INDIA**

Tel: [+91] 80 5115 4501  
Fax: [+91] 80 5115 4502

**KOREA**

Tel: [+82] (2) 3424 2719  
Fax: [+82] (2) 3424 8620

**SCANDINAVIA**

Tel: [+45] 9614 0045  
Fax: [+45] 9614 0047

**SPAIN**

Tel: [+34] (91) 640 11 34  
Fax: [+34] (91) 640 06 40

**UK Burnham**

Tel: [+44] (0) 1628 604455  
Fax: [+44] (0) 1628 662017

**UK Stevenage**

Tel: [+44] (0) 1438 742200  
Fax: [+44] (0) 1438 727601  
Freephone: 0800 282388

**USA**

Tel: [+1] (316) 522 4981  
Fax: [+1] (316) 522 1360  
Toll Free: (800) 835 2352

*As we are always seeking to improve our products, the information in this document gives only a general indication of the product capacity, performance and suitability, none of which shall form part of any contract. We reserve the right to make design changes without notice.*

web [www.aeroflex.com](http://www.aeroflex.com)

Email [info-test@aeroflex.com](mailto:info-test@aeroflex.com)

November 2005