



SIDEWINDER

PULL AND ASSIST CAPSTAN WINCH

OPERATION & MAINTENANCE



70605 – USA

SIDEWINDER

Copyright 2009 by General Machine Products Co., Inc

QC Final Inspection by: _____

Date: _____

Unit Serial Number: _____

Build Date: _____

All rights reserved. No part of this publication may be copied, reproduced or transmitted in any form whatsoever without the written permission of General Machine Products Co., Inc.



GMP • 3111 Old Lincoln Hwy • Treose, PA 19053 • USA
TEL: +1-215-357-5500 • FAX: +1-215-357-6216 • EMAIL: info@gmptools.com

March 29 2010 USA Ver 4
Manual P/N 27918

REVISION HISTORY:

Rev No.	Date	Details	Author
01	03-2006	Original issue	A Miller
02	05-2007	US Version	A Konschak
03	09-2009	Update manual to be consistent with others	A Konschak
04	03-2010	Added figure 8 instruction and illustrations	A Konschak

CONTENTS

- 1.0** Introduction
- 2.0** Safety Instructions
- 3.0** General Description
- 4.0** Specification
- 5.0** Operating Procedure
- 6.0** Maintenance and Servicing
- 7.0** Towing Instructions
- 8.0** Equipment Layout
- 9.0** Spare Parts

APPENDICES

- Appendix 1 Hydraulic Circuit Drawing

1.0 INTRODUCTION



Founded by engineer George M. Pfundt in 1936, GMP started operations in a downtown Philadelphia building as a specialty machine shop doing work for the local Bell Telephone company and for the electric utility company. GMP expanded to a production shop after landing a contract with Western Electric Com-

pany and, subsequently, forming a close relationship with Bell Telephone Laboratories in Murray Hill, N.J., which enabled it to manufacture prototypes of products for experimental use within the Bell System.



Having outgrown the original factory building, the company built a 100,000 square foot plant in Trevoose, PA (a Philadelphia suburb) and moved there in 1957. Today GMP is recognized as a premier worldwide supplier of specialty tools and equipment for the outside plant marketplace. The company's products are known for their robust design and durability to withstand many years of frequent use.



2.0 SAFETY INSTRUCTIONS

THIS EQUIPMENT MUST ONLY BE USED BY AUTHORIZED PERSONNEL, WHO HAVE BEEN SUITABLY TRAINED AND COMPETENT TO DO SO.



THESE INSTRUCTIONS ARE TO BE MADE AVAILABLE TO OPERATORS OF THIS EQUIPMENT AT ALL TIMES, FAILURE TO OBSERVE THESE SAFETY INSTRUCTIONS COULD RESULT IN SERIOUS PERSONAL INJURY AND / OR PROPERTY DAMAGE.

1. Read and understand the operation and maintenance manual supplied with this equipment. Keep it in a convenient place for future reference.
2. Keep children and untrained personnel away from this equipment while in operation.
3. Keep all guards and safety devices in place. Do not operate this equipment with guards removed or damaged.
4. Keep hands, feet and loose clothing away from moving parts.
5. Always stop the machine to carry out lubrication or servicing.
6. Check machine before starting for worn or damaged parts. Check that all nuts and bolts are tight.
7. If machine is left unattended, ensure that unauthorized use is prevented.
8. Never leave the machine unattended while in use.
9. Consider the use of safety barriers, especially when used in public places.
10. Beware of pinch points involved with rotating components, e.g. rope/cable drums, capstans, bullwheels, shafts and chain drives.
11. Beware of hot surfaces, especially around the engine, engine exhaust pipe and hydraulic oil tank.
12. Some component and assembly parts are in excess of 55lb (25kg) . When lifting care must be taken, ensure sufficient man power/lifting gear is available, to prevent personal injury and damage to the machine.
13. Beware of exposed electrical contacts especially around the engine. Do not touch, or allow metal objects to come into contact.
14. Waste engine and hydraulic oils are to be disposed of via an environmentally acceptable method – e.g. passed on for recycling.
15. Wear ear protection when engine is running to prevent ear damage.
16. Machine may cause additional fire hazard if involved in an existing fire due to gasoline, diesel, oil and hydraulic oils involved.
17. No personnel are to be in manholes or ducts when the winch is being operated.
18. The machine must be operated on firm ground.
19. Stay clear of cables or lines under tension.
20. Only use the machine for its intended purpose.
21. Do not tamper with pressure relief valves or pressure reducing valves.
22. Rear stabilizing props must be down and on solid surface before use.

3.0 GENERAL DESCRIPTION



The GMP SideWinder is a trailer mounted pull and assist capstan winch, mounted on a sturdy all-steel fabricated chassis. It is equipped with torsional suspension axles, stabilizing prop legs, a front telescopic jockey wheel and a tow bar with a Lunette Ring. The unit is easily pulled by a standard pickup truck.

The power source is a gasoline engine which drives the fixed displacement tandem mounted hydraulic pumps. The hydraulic pump is attached to the engine via a bell housing and flexible coupling. One pump powers a hydraulic motor, through an in-line planetary gearbox, to the capstan. The second pump drives the rope take-up drum again through a hydraulic motor. The hydraulic oil tank is fitted with double filtration protection, sight glass and filler/breather.

Controls are operator friendly and very simple to use. A spring centered lever controls the direction of rotation of the capstan, while a detented lever engages the take-up drum drive. A control knob is used to limit the rope/cable tension using the panel mounted tension indicator.

The rope take-up drum is removable and can be split to enable removal of rope. The capstan can be rotated through 90° on a swivel bracket from the inline working position to the transverse transit position when in tow. When the winch is in the working mode the rear props are extended out of the chassis to provide greater stability.

4.0 SPECIFICATION

Max. Pulling Capacity	1100 lbs	(500 kg)
Rope Speed Max.	200 ft/min	(60 m/min)
Capstan Diameter	32"	(813 mm)
Dimensions:	Length:	123" (3124 mm)
	Overall Width:	69" (1753 mm)
	Height:	57" (1450 mm)
	Weight:	1400 lbs. (635 kg)
	Track:	60" (1676 mm)
	Tire Size:	F78-14 205/75D14
	Coupling: Lunette Ring (Pintle hook)	
	Lighting Adapter: 7-Way (others available by request)	
Power Supply:	Honda GX390 13 HP, Recoil Start, Overhead Valve, Cast Iron Cylinder Sleeve, 1.5 Gallon tank	
Load Indication:	Calibrated gauge bezel	
Main Drive:	Fixed displacement tandem pumps to fixed displacement high torque motors.	
Gear Box:	In-line planetary gearbox (capstan drive)	
Gear Oil Grades:	MobileLube HD Plus 85W-140	
	Refer to the instruction manual supplied with the gearbox for alternative oil types and grades	
Controls: (see section 8)	<ul style="list-style-type: none"> (a) Pay-in / pay-out spring centered control valve. (b) Detented take-up drum drive control valve. (c) Tension control knob (d) Tension indicator 	
Hydraulic Circuit:	Closed circuit system with full filtration and overload protection	
Hydraulic Oil Tank Capacity:	16.5 Gal. (63 Liters)	
Hydraulic Oil Grade:	Tellus T-32	

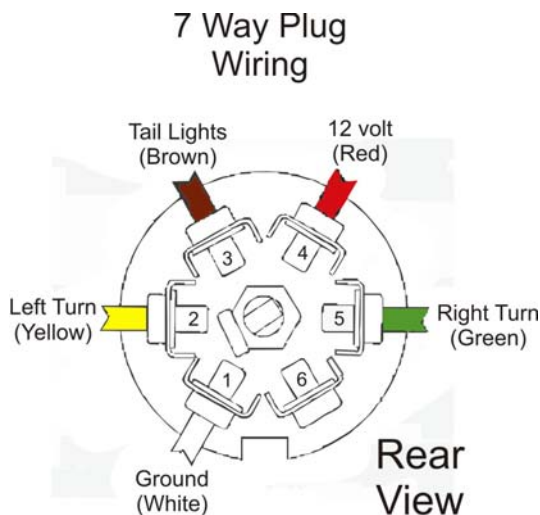

5.0 OPERATING PROCEDURE

IT IS IMPERATIVE THAT ALL PERSONS USING, OPERATING OR MAINTAINING THIS WINCH BE FULLY TRAINED AND COMPETENT TO DO SO, AND HAVE READ THE ENTIRE OPERATING MANUAL.

GMP CANNOT BE HELD RESPONSIBLE FOR MIS-USE OF THIS EQUIPMENT.

5.1 CONTROLS

The operator controls have been designed to be safe and simple to use, with regard to ergonomic considerations. The operators control station is complete with the following: (see section 8)

- (a) Control lever for winching in and paying out. This provides bi-directional selection of capstan rotation. The valve spool has a soft start facility allowing for a limited creep and inching movement.
- (b) Control lever for operation of the rear take-up drum. This lever should be in its operating position before operating the capstan. If the winch is not being used, this lever should be returned to its non-operating position, thus saving on fuel and preventing the hydraulic oil from overheating.
- (c) Tension control knob. This can be used to limit the actual pulling tension applied to the capstan.
- (d) Pressure gauge which is also an indication of the pulling tension.

5.2 PRE-WINCHING PROCEDURE

Prior to using the winch for any hauling application, it is important to ensure that the rear prop legs are extended and lowered in order to level the winch, and that the front jockey wheel is also lowered to a position where the winch is firm and stable. The winch should be securely anchored to either a suitable vehicle, ground anchors or other substantial holding point. The winch should be in line with the direction of pull.

Refer to the pre-winch maintenance checks in section 6.1.

The capstan must be rotated from the "Transverse" transit position to the In-Line working position. Ensure that the retaining pin and hair-pin are correctly replaced.

It may be necessary to remove the lighting board. This is accomplished by first un-plugging the connector from the rear jack on the trailer, and then pulling the spring loaded release pins. The complete lighting board can then be removed and stored safely.

5.3 PAYING OUT ROPE

The rope take-up drum should be de-clutched by removing the lynch pin at the end of the drum shaft, grasping the drum flange, pulling and then rotating. Once the drum is free from its drive clutch, it is free to rotate on the shaft and the rope can be pulled manually from the drum.

5.4 STARTING THE ENGINE

The engine manufacturer's operating and service manual form an integral part of this manual. It is recommended that these instructions are read and fully understood by all operating personnel before starting the engine.

Before starting the engine, check the fuel level, engine oil level and oil level in hydraulic tank.

5.5 PULLING IN

5.5.1 The rope should be wrapped around the capstan such that:

- (a) The rope to take-up drum comes off the **top of the capstan** and is furthest away from the operator.
- (b) The rope to the fiber cable (load side) comes off the **top of the capstan**, and nearest to the operator and gearbox. Approximately four to five complete turns are required.

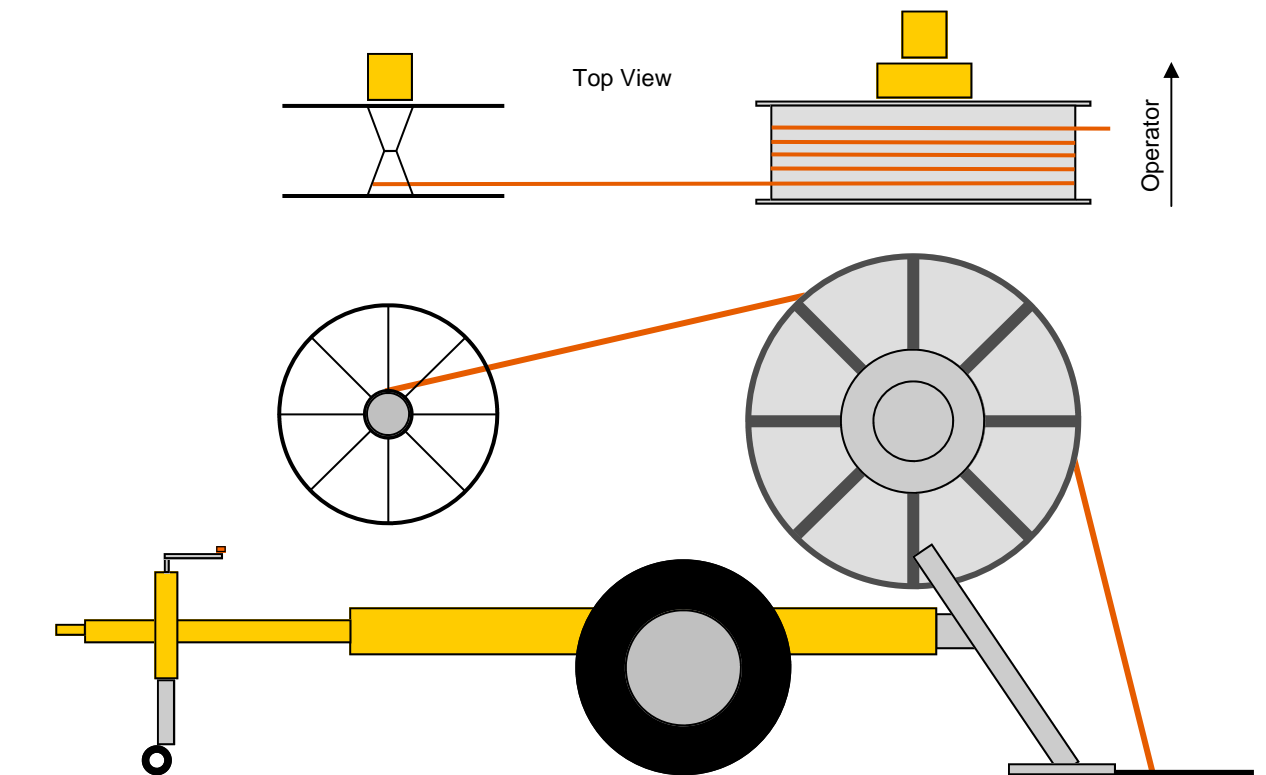

5.5.2 Operate the drum control lever to engage the drum drive. This should be left in its operating position at all times that the winch is working. At all other times it is advantageous to return the drum control lever to its non-operating position.

5.5.3 Operate the winch control lever by pulling gently towards the operator. The rope will now be pulled in and be wound onto the rope take-up drum. The speed of pulling can be increased or decreased by adjusting the engine speed control. The specific maximum pulling tension is adjusted by the operator by turning the tension control knob to suit the application.

When winching is completed, move the take-drum operating lever to the “off” position.

5.5.4 When being used as an assist winch, the drum drive is not required and therefore the operator should ensure that the lever is in the off position. Capstan wrapping of the cable should ensure that the high tension side should be nearest to the gearbox and hydraulic motor.

5.6.0 The winch is capable of being used to “figure 8” fiber cable. The capstan should be rotated to 45° and locked in place by the supplied bolt and nut as shown in photo below.

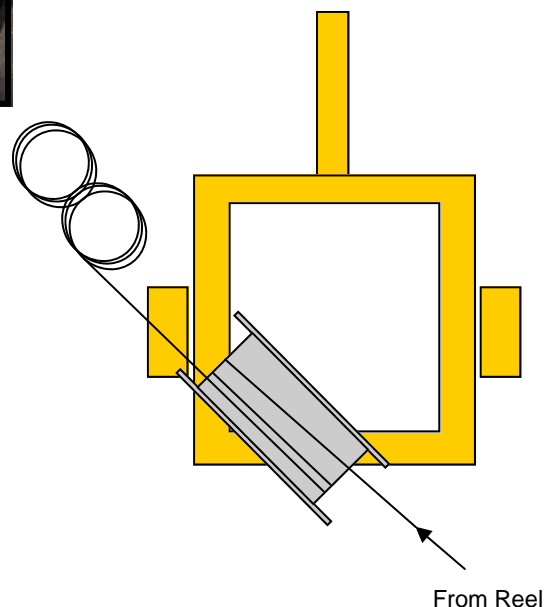

5.6 REMOVING ROPE FROM SPLIT DRUMS

The split drum has been designed to enable removal of the rope in a complete coil. In order to achieve this, ensure that the drum is fully engaged in its clutch and untie the rope from the drum.

It is often advantageous at this stage to tie a few wraps of waste string, tie wraps or tape around the rope coils, ensuring that the string does not pass around one of the drum spokes. This will help to keep the rope in a nice tight coil when released from the drum.

To remove the rope from the drum, first remove the retaining pin on the drum's drive shaft. Remove the locking bolt from the drum flange-retaining nut. The ears on the nut can now be used to release the nut by rotating counter-clockwise. Because of the tightness of the rope on the drum, a soft-faced hammer may be used on the retaining nut's ears to help with the initial movement. The nut and outer drum flange may then be removed. The rope coil may now be removed. Re-assemble the drum.

5.7 ON COMPLETION OF THE WINCHING OPERATION

The machine should be wiped down and cleaned.

The capstan should be returned and fixed in the transverse transit position.

The lighting board should be re-fitted and the light operation checked.

The winch should be preferably stored in a dry place e.g. garage or workshop.

6.0 MAINTENANCE AND SERVICING

It is recommended that this winch is serviced every 12 months, regardless of its condition or the number of operating hours used. This will help to ensure reliable, trouble free service. It is imperative that any maintenance work is carried out by personnel suitably trained and qualified to do so.

6.1 PRE-WINCHING MAINTENANCE CHECK

This should be carried out each day prior to the start of winching.

6.1.1

Check the hydraulic oil level. Oil should be visible within the black lines marked on the hydraulic oil level sight gauge. Replenish if necessary with the correct grade of hydraulic oil to suit the climatic conditions. (Refer to the section 4 for grades of hydraulic oil required).

6.1.2

Check the engine oil level as indicated in the engine manufacturers manual. Replenish if necessary.

6.1.3

Check that there is enough fuel in the tank to complete the planned winching schedule.

6.1.4

Check the condition of the hydraulic hoses, replace if damaged.

6.1.5

Check the condition of the pulling rope, particularly where it joins the drum. Only use a good condition rope of suitable pulling capacity

6.1.6

Check that all screw fasteners are tight.

6.1.7

Check the hydraulic oil system for leaks, rectify before proceeding.

6.1.8

Clean any dirt or debris from the take-up drum shaft and capstan face.

6.2 MONTHLY MAINTENANCE

This should be carried out at intervals not exceeding 4 weeks. These intervals will depend upon the degree of use of the winch.

6.2.1

Carry out all the pre-winchng checks as detailed in 6.1

6.2.2

Check the function of all the lighting equipment, this should be more frequent if regular problems arise.

6.2.3

Check and adjust the tire pressures.

6.2.4

With the engine and drum shaft running, check the return filter condition indicator. This is a red/green indicator mounted on the hydraulic oil tank return line filter. If the indicator is well over into the red area, replace the filter.

6.2.6

Grease all bearings and grease fittings.

6.2.7

Oil all moving parts to prevent corrosion.

6.2.8

Apply oil to all oilite bushes.

6.2.9

Check the condition of the towing breakaway chain. If damaged, replace immediately.

6.3 ANNUAL SERVICING

This should be carried out at approximately 12 monthly intervals by a qualified and experienced workshop team.

6.3.1

Carry out all the work as specified above in section 6.2

6.3.2

Drain the hydraulic circuit of oil. Clean the filler/breather and replace. Renew the suction filter element and return line filter element. Refill with fresh oil. Check and reset all relief valves, (Refer to section 6.4 for further information). Refer to section 4 for grades of hydraulic oil.

6.5.3

Service the engine as per the engine manufacturers manual supplied with the winch.

6.5.4

Check the condition of the tires, and running gear. Adjust and reset if necessary.

6.5.5

In-line planetary gearbox (capstan drive):

Change the gearbox oil, (refer to section 4 for gear oil grades) refer to the instruction manual supplied with the gearbox for further details on maintenance and servicing.

6.4 RELIEF VALVE SETTING

Reference should be made to the hydraulic circuit diagram on page 19 of this manual. There are four relief valves in the circuit and with the exception of item 10, all have been factory pre-set and should not be adjusted. Item 10 is adjusted by the operator to set a maximum pulling tension.

If it is necessary to replace or adjust any of the relief valves, the following guidance should assist.

Item 7 This is a Capstan directional control valve. The relief valve is mounted in the body of this control valve and is the main system relief valve. With a Dynamometer in the rope load line, and with 4 complete turns around the capstan, this relief valve should be set to relieve at 1200 lbs. (550 kg), approx. 1880 psi (130 Bar). Note: Relief valve adjustment is hidden by a protective cap and sealing washer.

Item 8 This relief valve is situated on the drum directional control valve. This controls the rope tension between Capstan 10 and Drum when pulling in. The valve should be set to relieve when the rope tension measures approx. 85-110 lbs. (40-50 kg). This measurement and adjustment should be made when the rope drum is almost empty. Note: Relief valve adjustment is hidden by a protective cap and sealing washer.

Item 2 This relief valve is mounted in an aluminum body connected to the drum hydraulic motor. This valve prevents drum overrun when paying out under power. With the rope drum almost empty, the relief valve can be set so that a rope tension of approx. 85 lbs. (40 kg) will cause the drum to rotate.

Item 10 This relief valve is mounted in an aluminum body connected to the capstan hydraulic motor. It is intended that the site supervisor will set this relief valve to give maximum rope tension to suit specific operating conditions. There are two adjustments, limiting forward and reverse.

Control Panel Rear

Control Panel Front



Item 8

Item 10
(Forward Capstan)

Item 7



Item 10
(Reverse Capstan)

Item 2

7.0 TOWING INSTRUCTIONS

BEFORE TOWING

- A. Check the load is distributed to give a positive hitch weight to ensure stable towing. Also ensure the hitch weight is within limit of the vehicle.
- B. Ensure that the Pintle hook is locked and the safety chains are securely attached to the tow vehicle.
- C. Make sure that the Jockey wheel is rotated up in the driving position and that the rear prop legs are securely retracted and locked.
- D. Make sure all trailer lights are working properly.
- E. Check tires for proper inflation.

8.0 EQUIPMENT LAYOUT

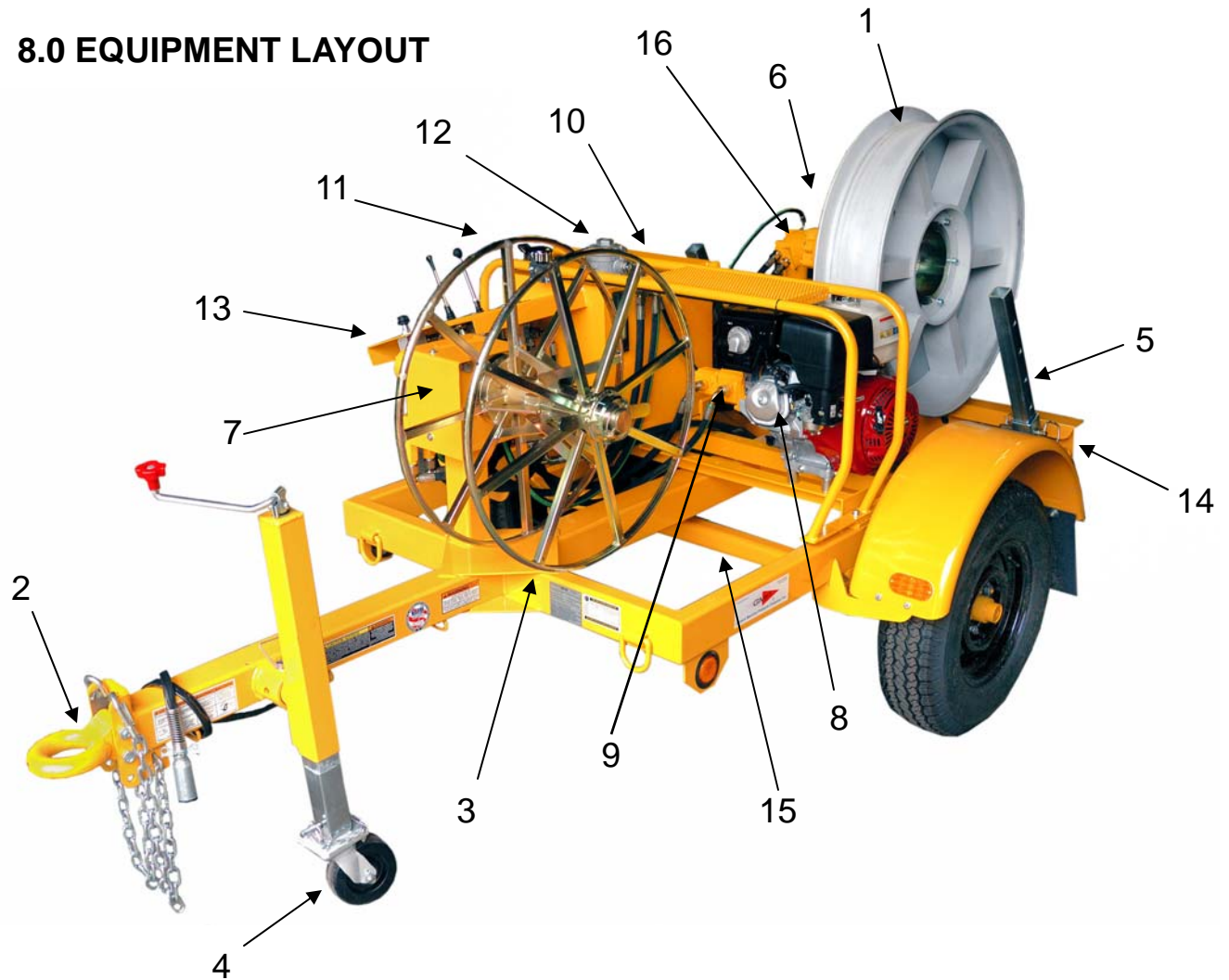

- 1 CAPSTAN
- 2 TOW BAR
- 3 ROPE TAKE-UP DRUM
- 4 JOCKEY WHEEL
- 5 REAR PROP LEG
- 6 CAPSTAN DRIVE GEARBOX
- 7 ROPE TAKE-UP DRUM HYDRAULIC MOTOR
- 8 ENGINE
- 9 HYDRAULIC PUMPS
- 10 HYDRAULIC OIL TANK
- 11 HYDRAULIC OIL TANK FILLER / BREATHER
- 12 RETURN LINE FILTER
- 13 CONTROL PANEL
- 14 REAR LIGHTING BOARD
- 15 AXLE AND WHEELS
- 16 CAPSTAN HYDRAULIC MOTOR

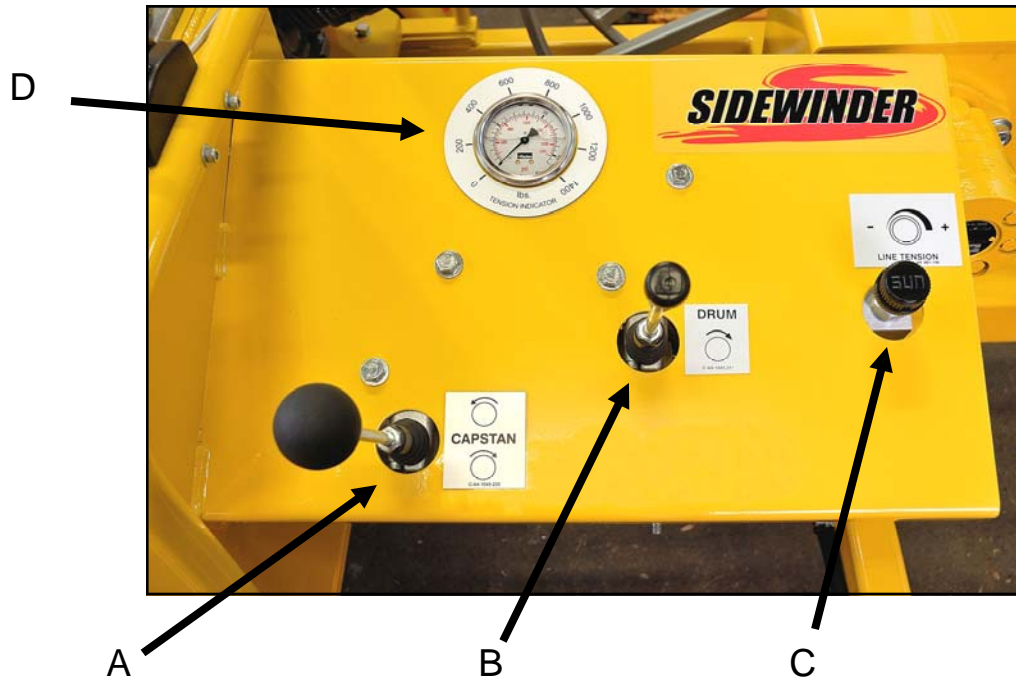

CAPSTAN WINCH CONTROL PANEL

- A. WINCH IN / PAYING OUT CONTROL LEVER
- B. ROPE TAKE-UP DRUM OPERATION CONTROL LEVER
- C. TENSION CONTROL KNOB
- D. PRESSURE GAUGE / TENSION INDICATOR

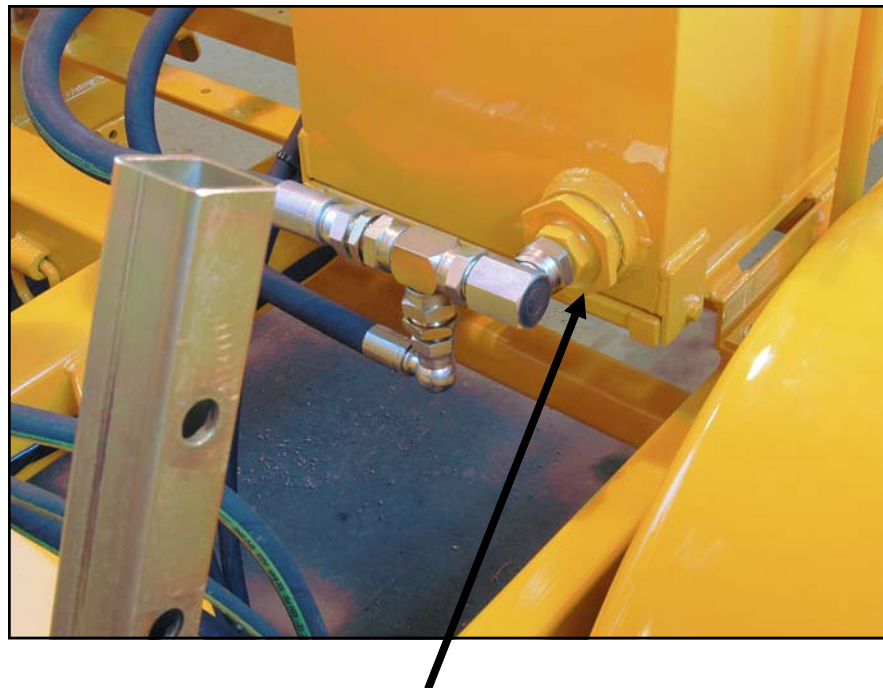

HYDRAULIC OIL TANK SUCTION FILTER

9.0 USER REPLACEABLE PARTS

Return Line Filter Replacement

Replace the Return Line Filter when the filter gauge is in the red (indicating higher return pressure - i.e., clogged filter). The gauge is found on the side of the filter housing and is green when filter is good.



1. Unscrew the return line filter top cap with a 42mm wrench or socket and remove.

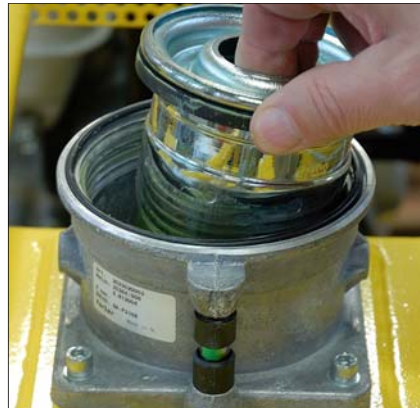

2. Remove old filter and replace with the new one.



3. Replace the top cap making sure not to cross the thread. Check for leaks after tightening.

Typical User Replaceable Parts:

Part Number:

Oil Tank Filler Breather	32073
Oil Tank Suction Filter	32134
Return Line Filter	34421
Sight Level Gauge	32053

For spare parts, call:

General Machine Products Co. 3111 Old Lincoln Highway Trevose, PA 19053
Tel: +1.215.357.5500 Fax: +1.215.357.6216 Email: info@GMPtools.com

Hydraulic Circuit Drawing

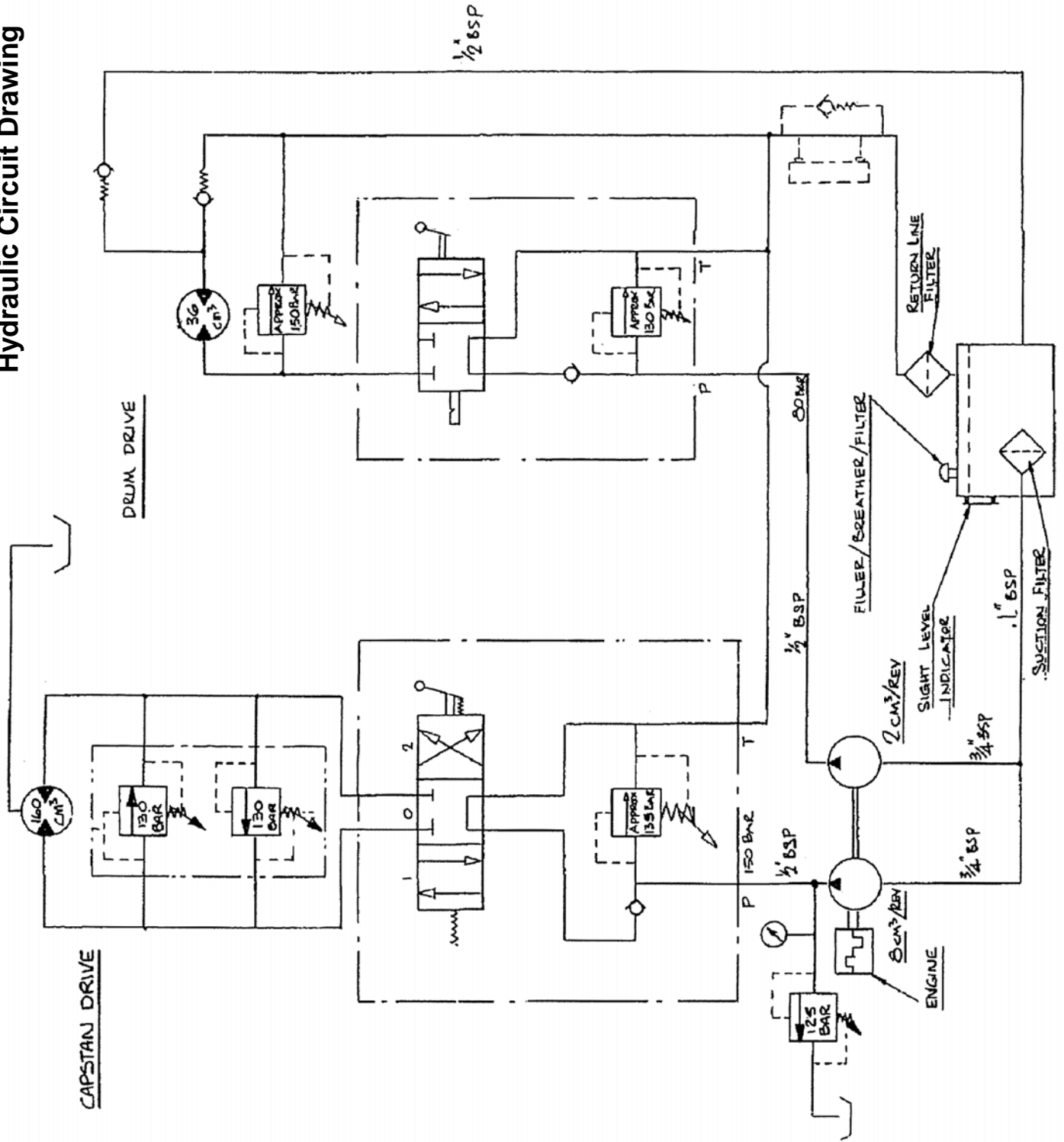

GMP LIMITED WARRANTY

1a. General Machine Products Co., Inc. ("GMP") warrants to the purchaser and/or end user:

(1) that a new product sold and manufactured by GMP will be free from original defects in material and workmanship for one year from the date the product was delivered to the purchaser and/or end user, or for the lifetime of the Modular Plug Presser;

(2) that a new product sold and not manufactured by GMP will be covered exclusively by the manufacturer's warranty. However, if that warranty coverage shall provide less coverage than the GMP Warranty for its manufactured products, then the warranty set forth in Paragraph 1(a) above shall apply instead;

(3) that a reconditioned used GMP product sold by GMP, or a non-owned product repaired by GMP, or a new part sold by GMP, will be free from original defects in material and workmanship for ninety days from the date the product was delivered to the purchaser and/or end user.

1b. The above warranties are contingent upon and subject to the condition that: (1) the end user substantiates the date it purchased and received delivery of the product or part, and (2) the product or part shall have been installed, maintained and used in accordance with GMP's or the manufacturer's written instructions.

2. The end user shall determine the suitability of GMP's product or part for intended use, and the end user assumes all risk and liability whatsoever in connection therewith except to the extent set forth in this Limited Warranty.

3a. GMP reserves the right to request that the product or part be returned to us for examination and cannot be responsible for user charges incurred in the replacement of any product. GMP's agreement to repair or replace is also subject to its inspection of the product and verification of the defect.

3b. Subject to immediate written notification of a defect or malfunction, GMP will repair or replace that product or part, at GMP's option, returned freight prepaid to Trevoze, PA.

3c. To obtain repair or replacement service under the Limited Warranty, the purchaser must contact the factory for a Return Material Authorization (RMA). Once obtained, send the RMA along with the defective part or product, transportation prepaid to:

General Machine Products Co., Inc.

3111 Old Lincoln Highway
Trevoze, PA 19053 USA
Tel: 215.357.5500

3d. The field labor and material charges incurred by an authorized GMP dealer or an end user to disassemble, inspect, repair and reassemble our product or part at their respective prime locations will not be reimbursed unless GMP has first reviewed and approved those charges.

3e. Incidental repair charges incurred by an authorized dealer or an end user for items such as



labor, transportation, tolls, lodging and meals at a location remote from its prime facility, or to demount our product or part from its remote location and forward to its prime facility, are not the responsibility of GMP, and are not covered by this Warranty.

3f. Incidental repair charges incurred by an authorized GMP dealer or end user to remove construction hardware, modify a vehicle or otherwise gain access to GMP's product or part, is a condition beyond GMP's control, and is not covered by this Warranty.

4a. GMP products or parts which become part of a total assembly which has been designated and/or manufactured by others, are not covered by this Warranty unless GMP reviews the total assembly and expressly extends its warranty.

4b. Design, material and workmanship furnished by others to install or operate a GMP product or part are not covered by this Warranty with respect to GMP's products or parts which are used in that particular assembly.

4c. Hydraulic, pneumatic, electrical or mechanical control equipment which is not manufactured by GMP and which becomes a part of a GMP assembly, is not covered by this Warranty.

4d. This warranty does not cover a GMP product or part which others have subjected to abuse, improper installation, improper operation, alteration or negligence in storage or handling.

5a. THE ABOVE WARRANTIES ARE EXCLUSIVE AND ARE IN LIEU OF ALL WARRANTIES OF MERCHANTABILITY, FITNESS FOR PURPOSE OR OTHER WARRANTIES OR GUARANTEES OF ANY KIND OR DESCRIPTION, EXPRESS OR IMPLIED.

5b. GMP ASSUMES NO LIABILITY WHATSOEVER, INCLUDING WITHOUT LIMITATION, ANY INJURY, LOSS OR DAMAGE, IN CONNECTION WITH THE INSTALLATION OR USE OF THIS PRODUCT OR PART, EXCEPT AS STATED IN THIS LIMITED WARRANTY. GMP WILL IN NO EVENT BE LIABLE FOR DIRECT, INDIRECT, SPECIAL, INCIDENTAL OR CONSEQUENTIAL DAMAGES ARISING OUT OF THE USE OR INABILITY TO USE THE PRODUCT OR PART.

5c. GMP'S SOLE LIABILITY AND THE PURCHASER'S SOLE REMEDY FOR A FAILURE OF A PRODUCT OR PART UNDER THIS LIMITED WARRANTY, AND FOR ANY AND ALL CLAIMS ARISING OUT OF THE PURCHASE AND USE OF THE PRODUCT OR PART SHALL BE LIMITED TO THE REPAIR OR REPLACEMENT OF THE PRODUCT OR PART THAT DOES NOT CONFORM TO THIS WARRANTY.

6. GMP reserves the right, without notice, to make changes in equipment design or components as progress in engineering or manufacturing methods may warrant.

7. This Warranty shall be construed in accordance with the laws of the State of Pennsylvania, of The United States of America.

8. This Limited Warranty may not be modified, in whole or in part, except by writing signed by an authorized officer of GMP.



GMP • 3111 Old Lincoln Hwy • Trevose, PA 19053 • USA
TEL: +1-215-357-5500 • FAX: +1-215-357-6216 • EMAIL: info@gmptools.com

