

***Minuteman***<sup>®</sup>  
***Parker***<sup>®</sup>

LV02675B  
LV02675BF  
LV0265H  
LV0265HF

**ALL PURPOSE VACUUM**

**OPERATION ■ SERVICE ■ PARTS ■ CARE**





DECLARATION OF CONFORMITY

**MANUFACTURER'S NAME:** Minuteman International Inc.

**MANUFACTURER'S ADDRESS:** 111 South Rohlwing Road  
Addison, IL. 60101

**EQUIPMENT DESCRIPTION:** APV

**EQUIPMENT MODEL DESIGNATION:** LV02675B, LV02675BF

Application of Council Directives: 89/392/EC, 2000/14/EC, 91/368/EC, 98/37/EC

Harmonized EN standards complied with: EN 292

Additional Standards: ISO 3744, ISO 11094

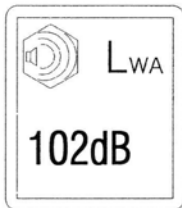

I, the undersigned, hereby declare that the equipment specified above conforms to the above Directive(s) and Standard(s).

**SIGNATURE:**

**DATE:** May 4, 2004

**PRINTED NAME:**

**Jeffrey Pollack**

**TITLE:**

**Standards Engineer**

## TABLE OF CONTENTS

<b>IMPORTANT SAFETY INSTRUCTIONS .....</b>	<b>4</b>
<b>TRAINING.....</b>	<b>4</b>
<b>WARNING .....</b>	<b>4</b>
<b>SAFE OPERATION .....</b>	<b>6</b>
<b>MAINTENANCE AND STORAGE .....</b>	<b>6</b>
<b>FUEL SAFETY .....</b>	<b>7</b>
<b>MACHINE OPERATION INSTRUCTIONS.....</b>	<b>8</b>
<b>WAND OPERATION .....</b>	<b>10</b>
<b>SAFETY DECALS .....</b>	<b>11</b>
<b>BASE ASSEMBLY .....</b>	<b>12</b>
<b>BASE ASSEMBLY BOM.....</b>	<b>13</b>
<b>HANDLE ASSEMBLY.....</b>	<b>14</b>
<b>HANDLE ASSEMBLY BOM .....</b>	<b>15</b>
<b>ENGINE ASSEMBLY – BRIGGS .....</b>	<b>16</b>
<b>ENGINE ASSEMBLY – HONDA.....</b>	<b>17</b>
<b>DELUXE ASSEMBLIES .....</b>	<b>18</b>
WAND ASSEMBLY .....	19
WAND DIVERTER ASSEMBLY.....	20
WAND DIVERTER ASSEMBLY BOM.....	21
WAND DIVERTER CONTROL LEVER ASSY .....	22
<b>LIMITED WARRANTY .....</b>	<b>23</b>

# **IMPORTANT SAFETY INSTRUCTIONS READ ALL INSTRUCTIONS BEFORE USING**

## **Training**

- 1. Read instructions carefully. Be familiar with the controls and the proper use of the equipment.**
- 2. Never allow children or people unfamiliar with these instructions to use this outdoor equipment.**
- 3. Never operate while people, especially children, or pets are nearby. Keep bystanders at least 25 feet away from the area of operation**
- 4. Keep in mind that the operator or user is responsible for accidents or hazards occurring to other people or their property.**

## **Warning**

1. Under California, and under laws of several other states, you are not permitted to operation internal combustion's engine using hydrocarbon fuels on any forest covered, brush covered, or grass covered land, or on land with grain, hay, or other flammable agricultural crop, without an engine spark arrester in continuous effective working order. The engine on your power equipment, like most outdoor power equipment, is an internal combustion engine that burns gasoline, a hydrocarbon fuel. Therefore, your power equipment must be equipped with a spark arrester muffler in continuous effective working order. The spark arrester must be attached to the engine exhaust system in such a manner that flames or heat from the system will not ignite flammable material. Failure of the owner/operator of the equipment to comply with this regulation is a misdemeanor under California law, and may also be a violation of other state and/or federal regulations, laws, ordinances, or codes. Contact your local fire marshal or forest service for specific information about what regulations apply in your area.

2. Wear approved safety glasses when operating this equipment. The operation of any powered machine can result in foreign objects being thrown by high-speed rotating parts. Visually inspect the area to be cleaned to remove any objects that may be a hazard when thrown.

3. Wear work gloves, sturdy footwear, long trousers and hearing protection when operating this equipment. Do not use machine while barefoot or with open toed sandals.

4. Remove hearing protection and watch for traffic when operating near, or when crossing roadways.

5. Do not operate this equipment on a paved, gravel or hard surface unless the collection bag is installed. Discharged material may bounce from a hard surface.
6. Before inspecting or servicing any part of equipment, shut off engine, disconnect spark plug wire from spark plug, and make sure that all moving parts have come to a complete stop. Be aware that rotating blades slow down gradually after engine is shut off.
7. Before using, always inspect to see that the fan blades and fan mounting hardware are not worn or damaged. Replace any worn or damaged parts to keep machine safe and with good balance.
8. Never leave equipment unattended when engine is running. Shut off engine and disconnect spark plug wire from spark plug before leaving equipment.
9. Do not vacuum any burning or smoldering materials such as cigars, cigarettes, ashes or cinders.
10. Do not vacuum areas that have been recently treated with fertilizers, pesticides or herbicides. Follow chemical manufacturer's safety instructions regarding contact with treated areas.
11. Do not vacuum flammable liquids such as gasoline, kerosene, diesel fuel, paint thinner, etc.
12. Do not allow hands or any other part of the body or clothing inside the vacuum inlet.
13. Before removing or installing collection bag, shut off engine, disconnect spark plug wire from spark plug, and allow all moving parts to come to a complete stop.
14. If equipment jams or becomes clogged, immediately shut off engine, disconnect spark plug, and allow all moving parts to come to a complete stop. Use only a wooden stick to clear away debris.
15. Do not start engine or operate this equipment with any safety guards or housing removed.
16. Do not operate on terrain greater than a 20 degree grade.

## Safe Operation

- Operate machine only in the daylight or in good artificial light.
- Do not run engine in an enclosed area. Engine exhaust contains carbon monoxide gas is a deadly poison that is odorless, colorless, and tasteless. Do not operate this equipment near buildings, windows, or air conditioners.
- Exercise extreme caution on slopes and avoid excessively steep slopes.
- Always walk, never run.
- Use extreme caution when reversing or pulling the machine towards you.
- Do not change the engine governor or over run the engine.
- Do not tilt the equipment when starting the engine or switching on the motor.
- Do not start the engine when standing in front of the discharge chute.
- Never pick up or carry machine while engine is running.
- Stop the engine:
  - Whenever you leave the equipment
  - Before refueling

## Maintenance and Storage

- Keep all nuts and bolts and screws tight to be sure the equipment is in safe working condition.
- Never store the equipment with fuel in the tank inside a building where fumes may reach an open flame or spark.
- Allow engine to cool before storing in any enclosure.
- To reduce the risk of fire, keep the engine and fuel storage area clean and free of any grease or clumps of grass and leaves.
- Check the discharge area frequently for wear or deterioration.
- Replace worn or damaged parts for safety.
- If the fuel tank has to be drained, this should be done outdoors.

## **Fuel safety**

**Gasoline is highly flammable and its vapors are explosive. To prevent personal injury or property damage:**

- Do not add fuel if engine is running or still hot from recent operation. Allow engine to cool for at least three minutes.
- Store fuel in containers specifically designed for this purpose.
- Do not fill fuel tank indoors. After filling, wipe up any spills and move away from gasoline fumes before starting engine.
- Do not allow open flame, matches, or smoking in area.
- Fill fuel tank with fresh, clean unleaded regular automotive gasoline, (leaded regular and unleaded or leaded premium grades of gasoline are acceptable substitutes).
- Do not mix oil with gasoline.
- Clean the area around the fuel fill cap and remove the cap from the fuel tank. Insert a clean funnel into the fuel tank.
- Fill the tank to 1/2 inch below the bottom of the filter neck to provide space for any fuel expansion.
- Reinstall the fuel fill cap securely and wipe up any spilled gasoline.

**SAVE THESE INSTRUCTIONS**

# Machine Operation Instructions

Read operating instructions before operating equipment

**CAUTION:** The engine contains *no oil*. Before starting the engine, make sure the crankcase is filled with the proper amount and type of oil. Refer to the engine operations manual for proper lubrication of the engine. Read the engine manual carefully before operating the unit.

## Material handling

**DANGER:** Improper use of this equipment may result in serious injury.

- Heavy concentration of sand and gravel should be avoided. These materials are extremely abrasive, and while the APV is designed to handle moderate amounts of these materials it was not designed for heavy applications. Because these materials are extremely heavy, only small amounts should be allowed to collect in the bag because large amounts can cause poor handling and difficulty in pushing.
- The APV will handle most common types of debris found around industrial plants, commercial buildings, homes and farms. Acid contaminated materials, magnesium, dust and other DANGEROUS DEBRIS that is considered hazardous should not be handled with the APV unless approved by a regulating authority considered to be an expert in the handling of such materials.

## Height adjustment

Simply loosen the lower 4 sided knob on the left side of the handle weldment and then move the adjustment bracket until you achieve the proper height that is desired. Then tighten 4-sided knob to fix the bracket into position.

## Maintenance instructions

Warning: do not work on the APV with the engine running or idling. Bring machine and any rotating parts to a complete stop. Remove spark plug wire before attempting to service.

1. For servicing and operating instructions for engine refer to Engine Manufacturer's Service Manual. Careful attention to care of air cleaner and crankcase lubrication instructions will ensure longer engine life. KEEP ENGINE CLEAN
2. Clean the engine air cleaner every 10 hours of operation. More often under dusty conditions. Replace air cleaner if it is torn, punctured or uncleanable.



3. Be sure to keep oil at the proper level in the engine. Check the oil level each time you fill the fuel tank.
  
4. To drain the oil:
  - a. **Briggs and Stratton:** Twist the black body of the drain plug extension clockwise and pull out, remove the yellow cap and let the oil drain.
  - b. **Honda:** Remove the dipstick and tilt the machine on its side until the oil is completely drained.
  
5. Dust bag care:
  - a. Keep bag clean at all times.
  - b. Clean bag by turning inside out, attaching the bag to the machine, turn machine on and let the moving air clean the bag. Lightly tap on the bag to help free the trapped dust and debris.
  - c. Do not wash the bag; this will shrink the fabric, thus reducing the airflow.
  - d. Debris left inside of bag may cause spontaneous combustion, resulting in an explosion or fire.

# Wand Operation

(LV02675BF & LV0265HF models only)

Wand safety pointers:

1. Follow the operating instructions of the unit for engine speed, etc.
2. Care should be taken not to plug the hose by forcing too much debris into it at one time.
3. Stiff debris such as sticks and tree trimmings should not be picked up with the hose, as they may plug the hose.
4. If the hose becomes plugged, the engine must be shut off.
5. Remove hose from blower housing, remove all blockage from the hose and replace to blower housing before restarting engine.

Wand operating

1. Remove Wand end and hose from its storage position on the vacuum.
2. Making sure the engine is either off or at an idle, shift the handle on the Door control to the forward position. See picture 1
3. Pick up the Wand and use the vacuum to clean up following the Wand Safety Pointers above.
4. If the hose becomes plugged, first straighten out the hose to allow debris to travel down easier.
5. If the plugging situation still persists, shut off the engine and remove the hose from the blower housing by unscrewing the lock on the hose end adapter and removing the hose. Shake out the debris from the hose or use a stick to remove the debris.
6. Reinstall the hose end adapter, restart the engine and start using the Wand again.
7. To replace the Wand and hose on the vacuum, first turn the engine off or at idle. Move the Door control handle to its rearward position until it catches.
8. Replace the hose in its carry position on the vacuum with the Wand end installed as in picture

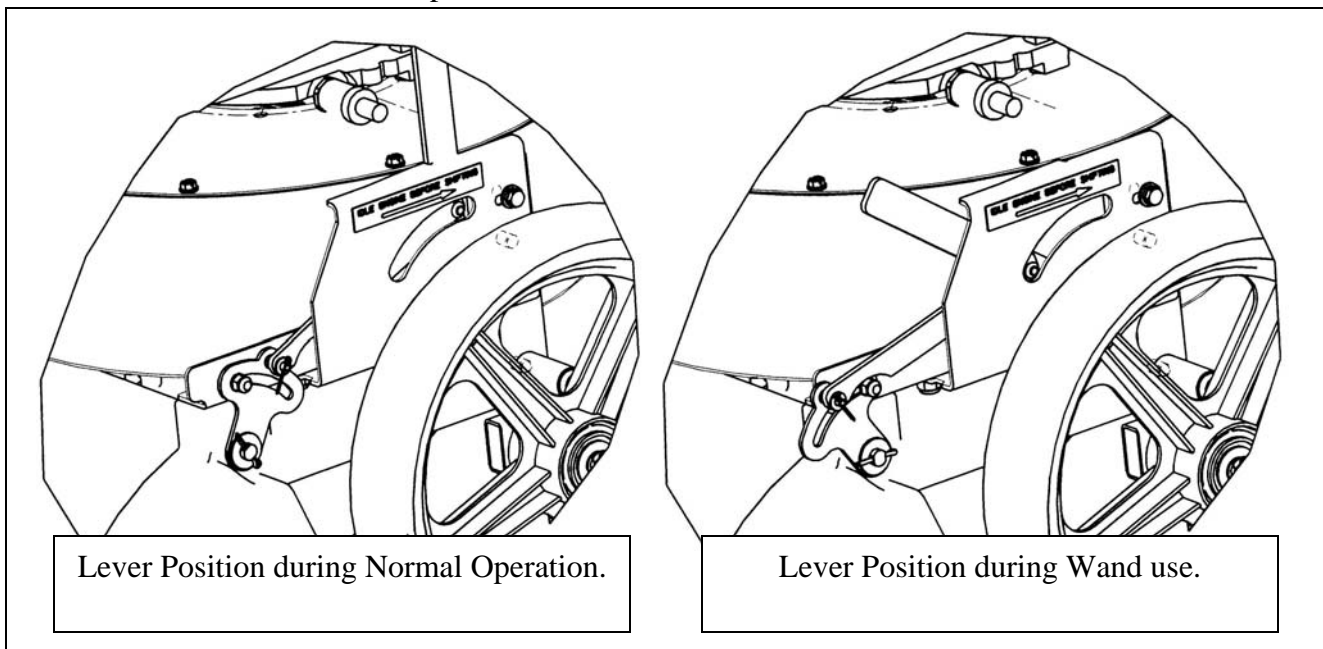

# Safety Decals

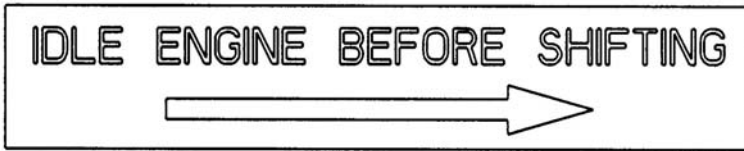

(USED ON LV02675BF & LV0265HF  
MODELS ONLY)

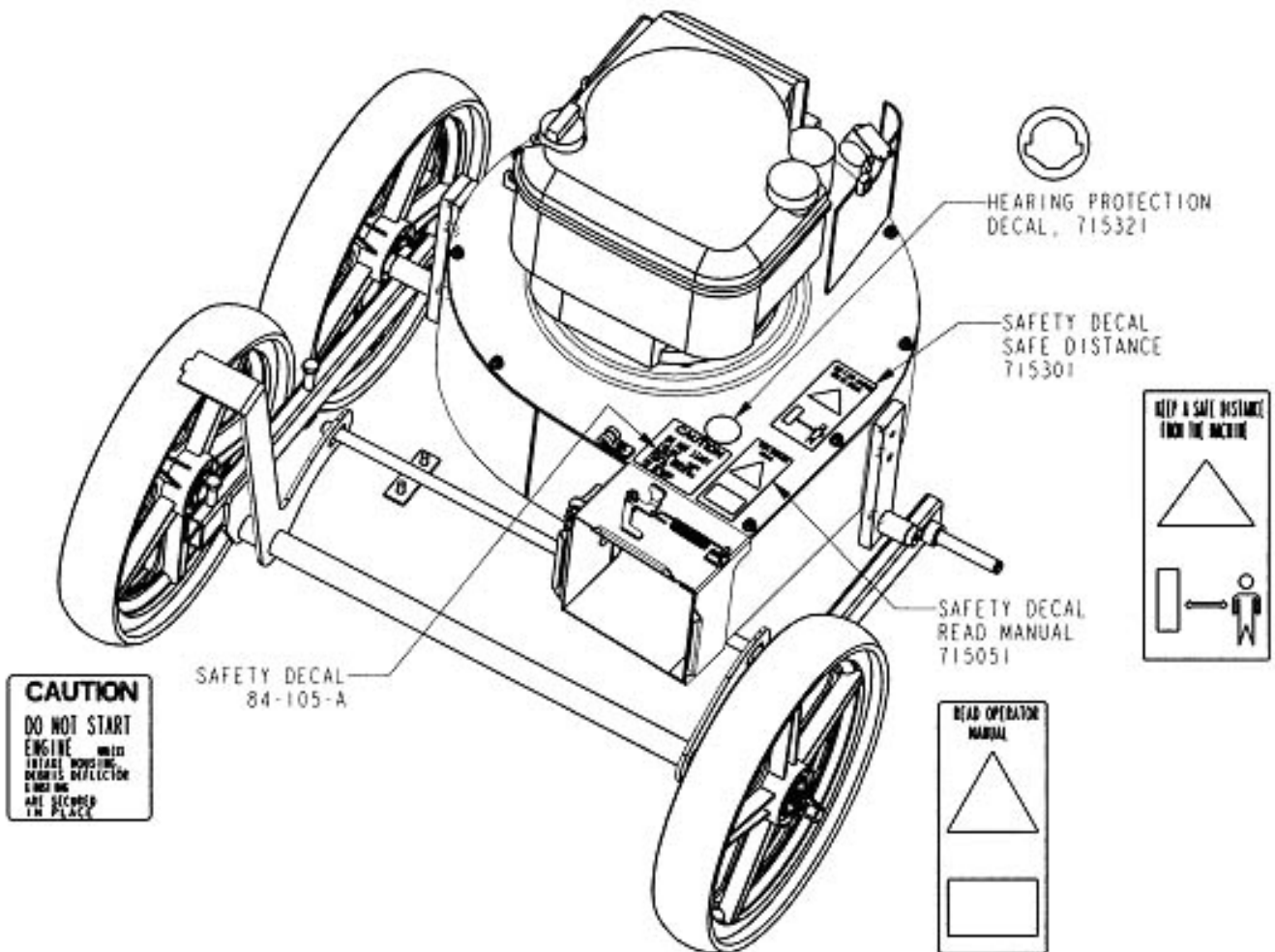

# Base Assembly

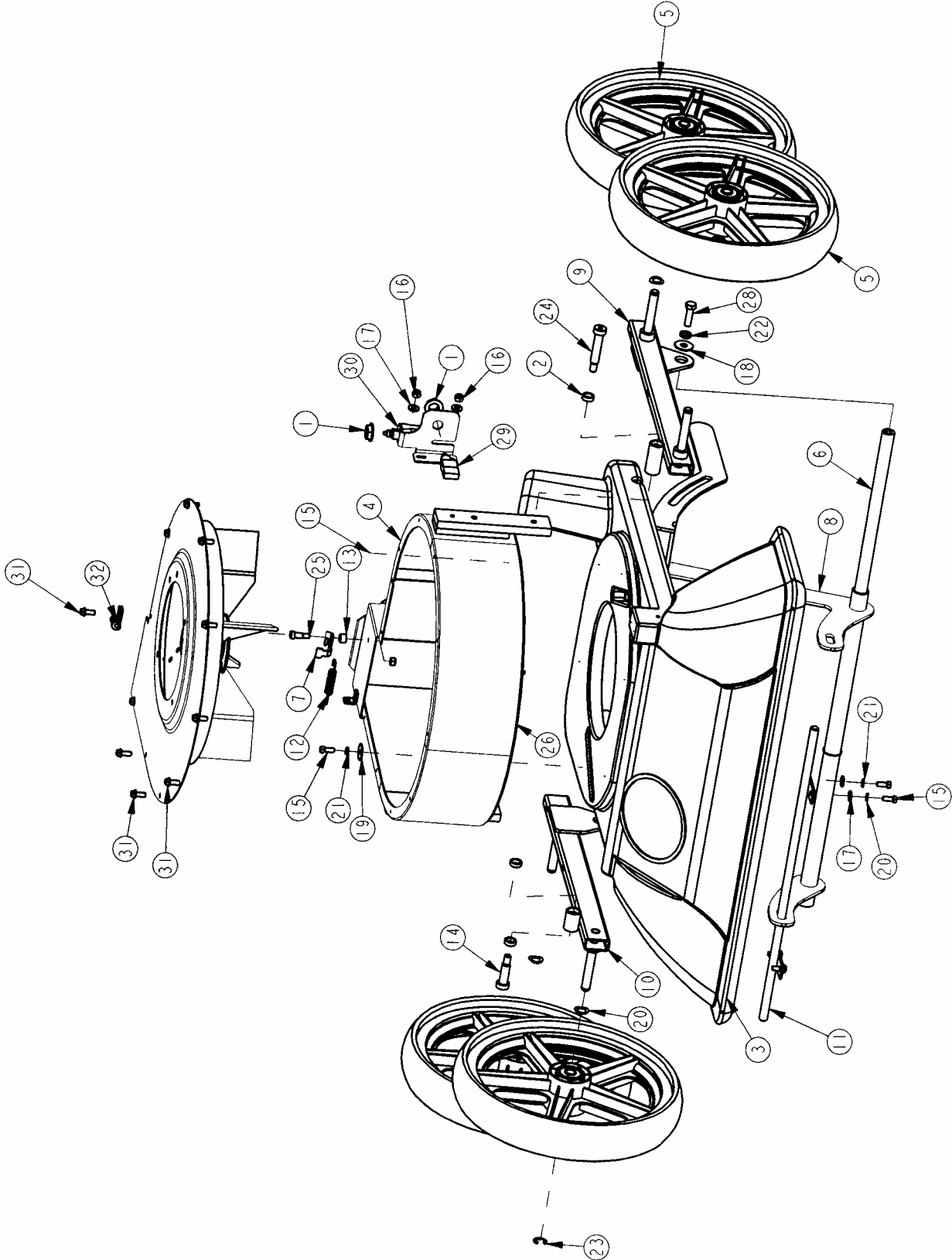

## Base Assembly BOM

<i>BILL OF MATERIAL</i>			
<i>ITEM</i>	<i>PART NO.</i>	<i>REQ'D</i>	<i>DESCRIPTION</i>
1	350135	2	SWITCH NUT
2	361103	4	OILITE BUSHING-.5IDX.25
3	410001A	1	MAIN HOUSING
4	410010	1	FAN HOUSING WMT ASSY
5	410051	4	WHEEL, SPARTECH 14"
6	410054	1	BAR, HEIGHT ADJUST LEVER
7	410061	1	PIVOT LEVER
8	410065	1	HEIGHT ADJUSTMENT LEVER WMT ASSY
9	410071	1	SIDE RAIL WMT ASSY
10	410076	1	SIDE RAIL WMT ASSY
11	410077	1	HEIGHT ADJUSTMENT HANDLE ASSEMBLY
12	430051	1	RETURN SPRING-3.00"
13	670626	1	SPACER, ROLLER
14	710992	1	BLT- SHLDR 1/2 X 1.25 STPL
15	711203	10	BLT-HH 1/4-20 X 0.62 STPL
16	711373	3	NUT-NYLOC 1/4-20
17	711505	6	WSR-FLAT 1/4
18	711507	2	WSR-FLAT .37 X 1.12 X .06
19	711519	6	WSR- FLAT .25 X 1.01 X .06
20	711524	4	WSR-WAVE .52 X .87 X .01
21	711544	10	WSR-HELICAL 1/4
22	711546	2	WSR-HELICAL 3/8
23	711713	4	RETAINING RING - "E" TYPE EXT .500
24	712120	1	BLT- SHLDR 1/2 X 2
25	712130	1	BLT-SHLDR 1/4-20 X .31 SH. DIA. X .50 SH. LEN.
26	713030	1	BLT-HH 5/16-18 X 1 3/4 #5
27	713034	1	BLT-HH 5/16-18 X 2.75#5
28	713043	2	BLT-HH 3/8-18 X 1 1/4 #5
29	740546	2	SAFETY SWITCH ASSY, APV
30	410060-1	1	SWITCH BRACKET, APV
31	72-416-10	10	BLT ST 1/4 X 5/8
32	78-120-A	1	P CLAMP (METAL & RUBBER)

# Handle Assembly

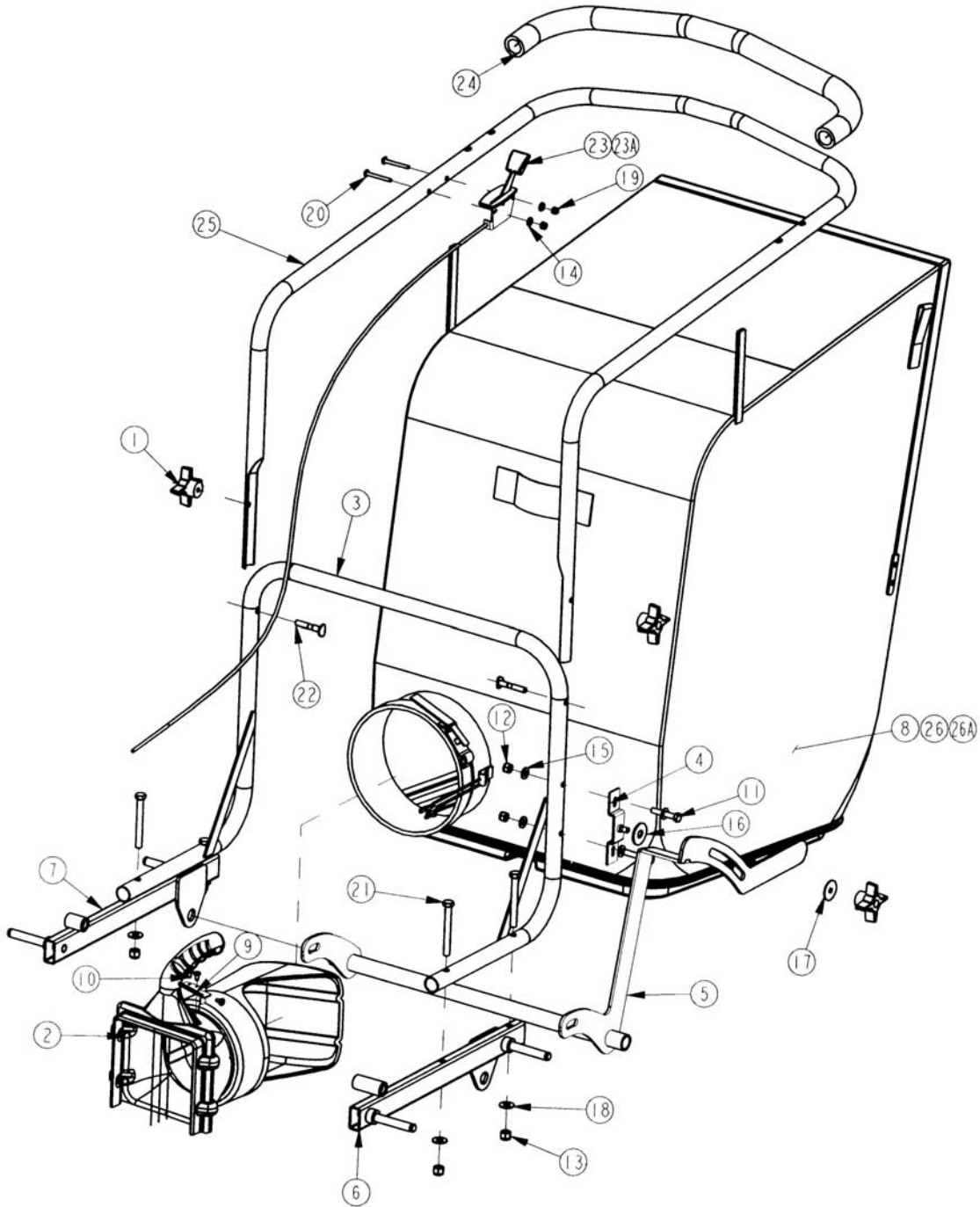

## Handle Assembly BOM

<i>BILL OF MATERIAL - HANDLE ASSEMBLY</i>			
<i>ITEM</i>	<i>PART NO.</i>	<i>REQ'D</i>	<i>DESCRIPTION</i>
1	350139	3	KNOB, 4 ARM 5/16-18
2	410004	1	BAG DISCHARGE CHUTE
3	410052	1	LOWER HANDLE WMT
4	410056	1	HEIGHT ADJUST PIN ASSY
5	410065	1	HEIGHT ADJUSTMENT LEVER WMT ASSY
6	410071	1	SIDE RAIL WMT ASSY
7	410076	1	SIDE RAIL WMT ASSY
8	410095	1	DISCHARGE BAG ASSY
9	410105	1	SWITCH DEPRESSION BRKT
10	711124	3	PAN HEAD ST #10 X .37 NI
11	711233	2	BLT-HH 5/16-18X1.75 ST PL
12	711374	2	NUT-NYLOC 5/16-18
13	711380	4	NUT-NYLOC 3/8-16 NUT
14	711503	2	WSR, FLAT#10
15	711506	4	WSR-FLT .344 X .690 X .062 STL ZINC
16	711510	1	WSR FLAT .5 X 1.37 X .100
17	711516	1	WSR- FLAT .31 X 1.25 X .05
18	712301	4	WSR-FLAT .87 X .38 X .06
19	712638	2	NUT, HEX 10-24 SS NYLOC
20	712815	2	SCR-MC 10-24X1.75 STPL
21	713050	4	BLT-HH 3/8-16 X 3 1/4 #5
22	69-516-32	2	BLT CONT HD 5/16 X 2
23	83-25-B-49	1	THROTTLE CABLE ASSY(BRIGGS ONLY)
23A	410115	1	THROTTLE CABLE ASSY (HONDA ONLY)
24	360108	1	SLEEVE, HANDLE
25	410081	1	HANDLE, APV W/THROTTLE
26	410116	1	BAG, DISCHARGE ASSY. APV POLY
26A	410117	1	BAG, DISCHARGE ASSY. APV CANVAS

# Engine Assembly – Briggs

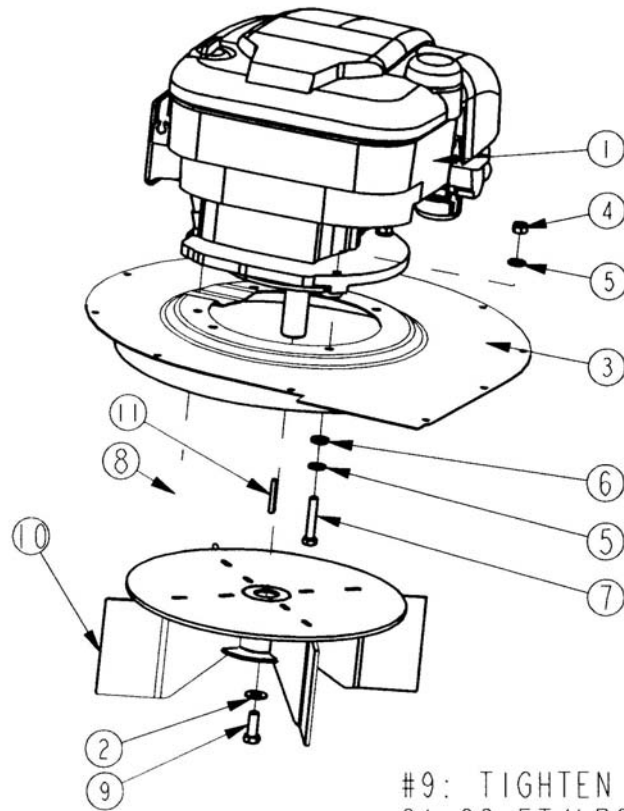

#9: TIGHTEN TO  
31-33 FT/LBS OF TORQUE

BILL OF MATERIAL			
ITEM	PART NO.	REQ'D	DESCRIPTION
1	350605	1	ENGINE, 6.75 HP B/S INTEK
2	360154	1	BELLEVILLE WASHER 3/8
3	410027	1	ENGINE MOUNT WMT
4	711374	3	NUT-NYLOC 5/16-18
5	711506	6	WSR-FLT .344 X .690 X .062 STL ZINC
6	711568	3	WSR-FLAT .344 X .688 X .125
7	713030	2	BLT-HH 5/16-18 X 1 3/4 #5
8	713034	1	BLT-HH 5/16-18 X 2.75#5
9	713039	1	BLT-HH 3/8-24 X 1.5 #5
10	410020BAL	1	FAN WELDMENT, APV - BALANCED
11	74-83-A	1	KEY, ENGINE SHAFT SV, APV



# Engine Assembly – Honda

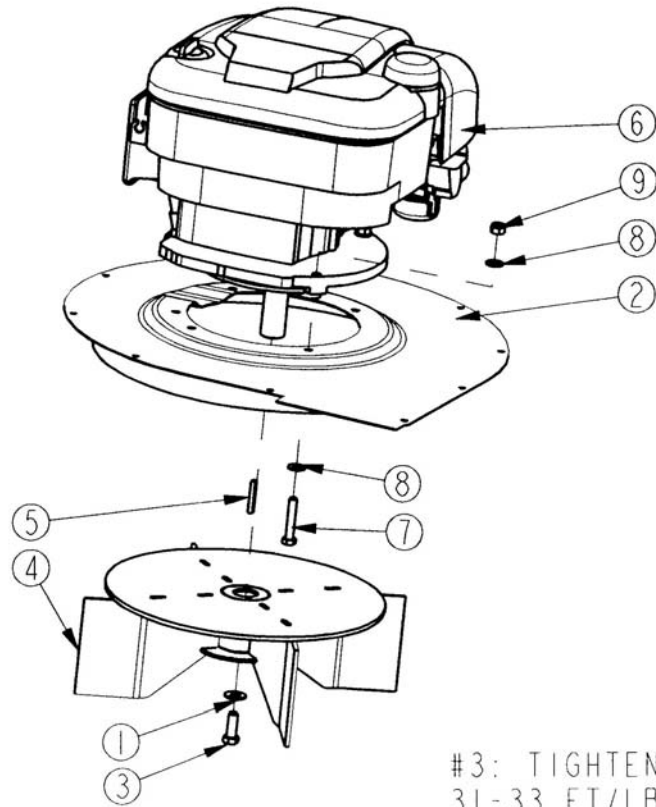

BILL OF MATERIAL			
ITEM	PART NO.	REQ'D	DESCRIPTION
1	360154	1	BELLEVILLE WASHER 3/8
2	410027	1	ENGINE MOUNT WMT
3	713039	1	BLT-HH 3/8-24 X 1.5 #5
4	410020BAL	1	FAN WELDMENT, APV - BALANCED
5	74-83-A	1	KEY, ENGINE SHAFT SV, APV
6	350607	1	ENGINE, 6.5 HP HONDA
7	711232	4	BLT-HH 5/16-18 X 1.50
8	711506	8	WSR-FLT 5/16 (NARROW) ST PL
9	711374	4	NUT-NYLOC 5/16-18

# Deluxe Assemblies

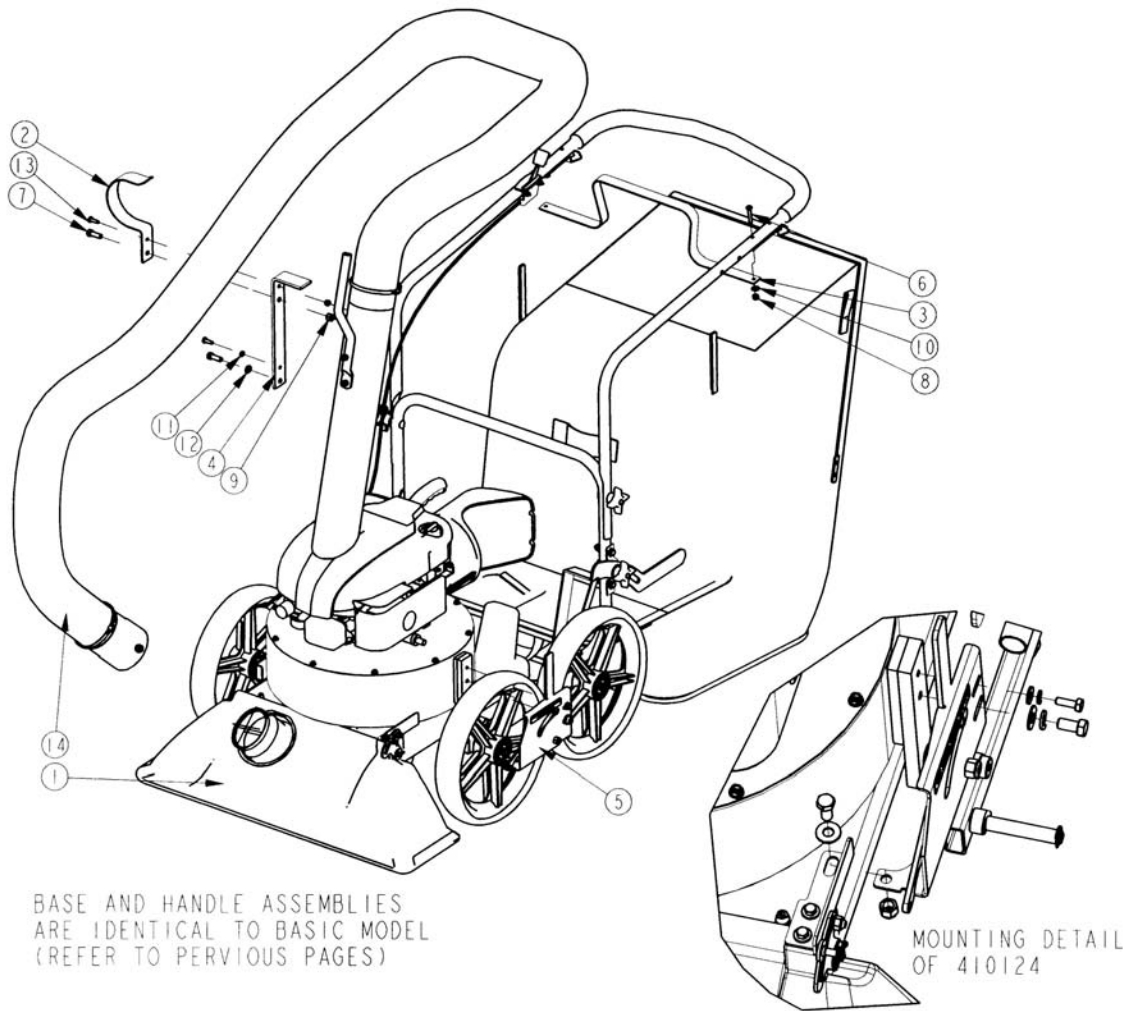

BILL OF MATERIAL			
ITEM	PART NO.	REQ'D	DESCRIPTION
1	410030	1	FLAP WITH VACFORM PARTS
2	410106	1	HOSE SUPPORT OUTER
3	410108	1	HOSE SUPPORT - BAR
4	410119	1	STAND, HOSE BRKT
5	410124	1	DOOR CONTROL GP
6	710600	1	SCR-MC 1/4-20X1.625 ZINC
7	711242	2	BLT-HEX 3/8 -16X1.00 ZP
8	711373	5	NUT-NYLOC 1/4-20
9	711380	5	NUT-NYLOC 3/8-16 NUT
10	711505	10	WSR-FLAT 1/4
11	711544	11	WSR-HELICAL 1/4
12	711546	3	WSR-HELICAL 3/8
13	713002	2	BLT-HH 1/4-20 UNC-2A X 3/4 STL#5
14	410063	1	HOSE ASSY, APV

# Wand Assembly

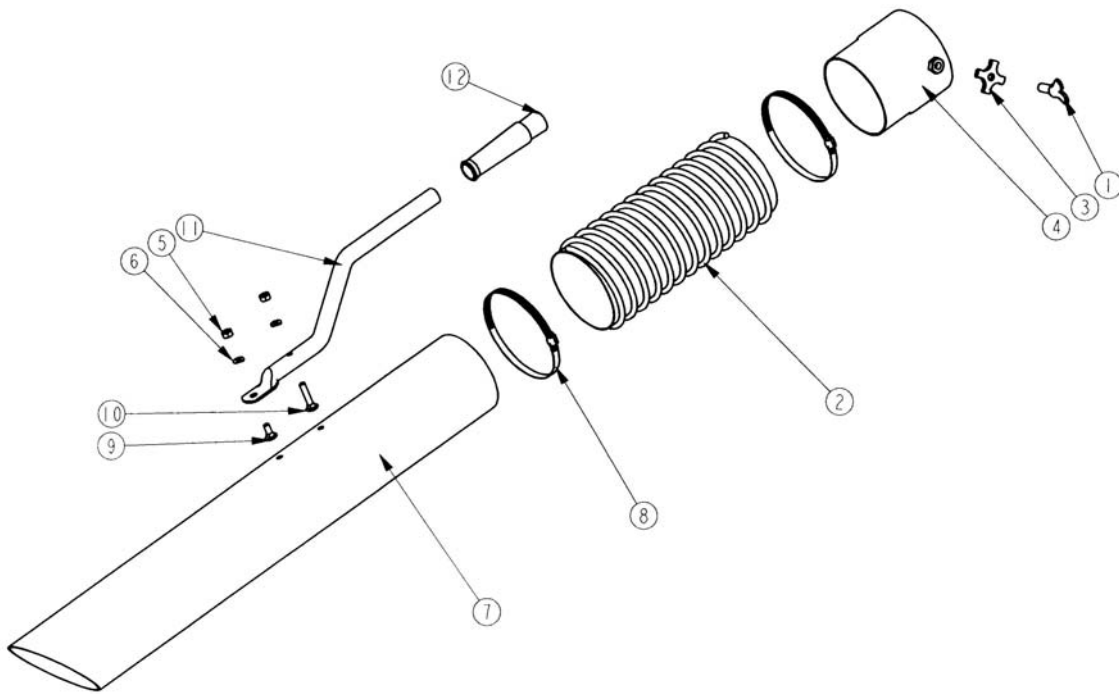

BILL OF MATERIAL - 410063			
ITEM	PART NO.	REQ'D	DESCRIPTION
1	260206	1	WING BOLT 3/8-16 X 1.00 ST PL
2	410103	1	HOSE-CLEAR/ BLACK REIN X 10'
3	410127	1	PLATE, 3/8-16 FINGER
4	410130	1	ADAPTER, TUBE
5	711316	2	NUT-HEX 1/4-20 ST PL
6	711544	2	WSR-HELICAL 1/4
7	410100-1	1	HOSE EXTENSION, BLACK TUBE
8	64-36-A	2	HOSE CLAMP 4 1/2
9	70-416-10	1	BLT-CARR 1/4-20 X .62
10	70-416-20	1	BLT-CARR 1/4-20 X 1.25
11	78-62-B	1	HANDLE, SNAPON HOSE KIT
12	78-71-A	1	HANDLE GRIP

# Wand Diverter Assembly

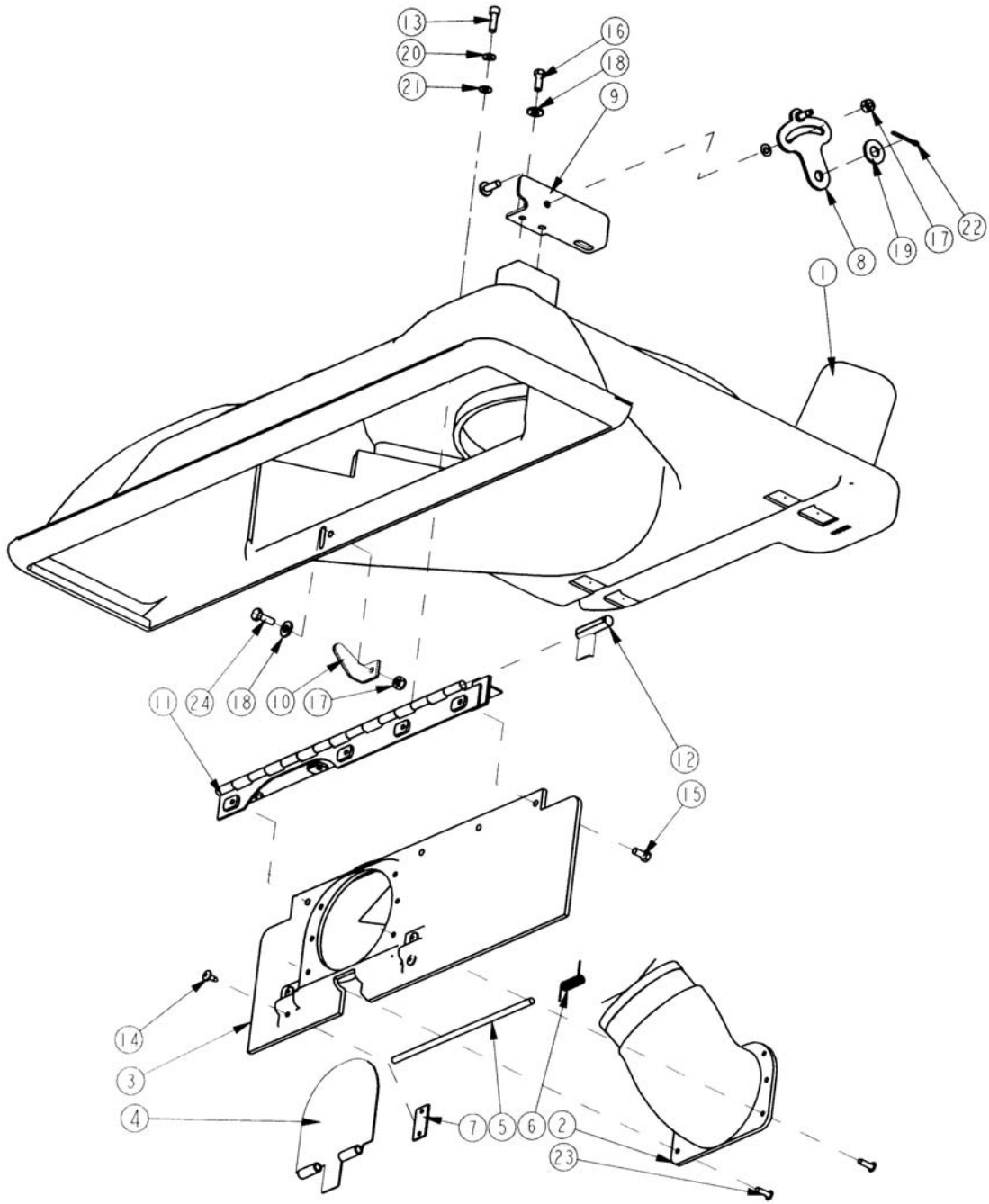

## Wand Diverter Assembly BOM

<i>BILL OF MATERIAL - 410030</i>			
<i>ITEM</i>	<i>PART NO.</i>	<i>REQ'D</i>	<i>DESCRIPTION</i>
1	410001	1	MAIN HOUSING
2	410006	1	ADAPTER FLANGE, HOSE
3	410031	1	MAIN-FLAP
4	410032	1	SECONDARY FLAP WMT
5	410034	1	HINGE PIN - SECONDARY FLAP
6	410035	2	SPRING, HOSE DOOR
7	410036	2	RETAINING BRKT - SECONDARY FLAP
8	410037	1	ENGAGEMENT LEVER - PRIMARY FLAP WMT
9	410040	1	ENGAGEMENT LEVER BRACKET ASSY
10	410041	1	ACTIVATOR - SECONDARY FLAP
11	410084	1	HINGE ASSY, MAIN FLAP
12	410111	1	FLAP ACTUATOR WELDM'T
13	710825	4	SCR-SC 1/4-20 X .75 ST PL
14	711144	4	SCR-ST-F 10-24 X .5
15	711202	4	BLT-HH 1/4-20 X 0.50 STPL
16	711203	2	BLT-HH 1/4-20 X 0.62 STPL
17	711373	2	NUT-NYLOC 1/4-20
18	711505	3	WSR-FLAT 1/4
19	711508	1	WSR-FLAT .44X 1.0X.08)
20	711544	8	WSR-HELICAL 1/4
21	711566	5	WSR-FLAT .259 X .500 X .07
22	711809	1	COTTER PIN, 1/8 X 1.0
23	711909	6	RIVET-POP .19 X .44 AL
24	712562	1	BOLT-HH 1/4-20X3/4 SS

## Wand Diverter Control Lever Assy

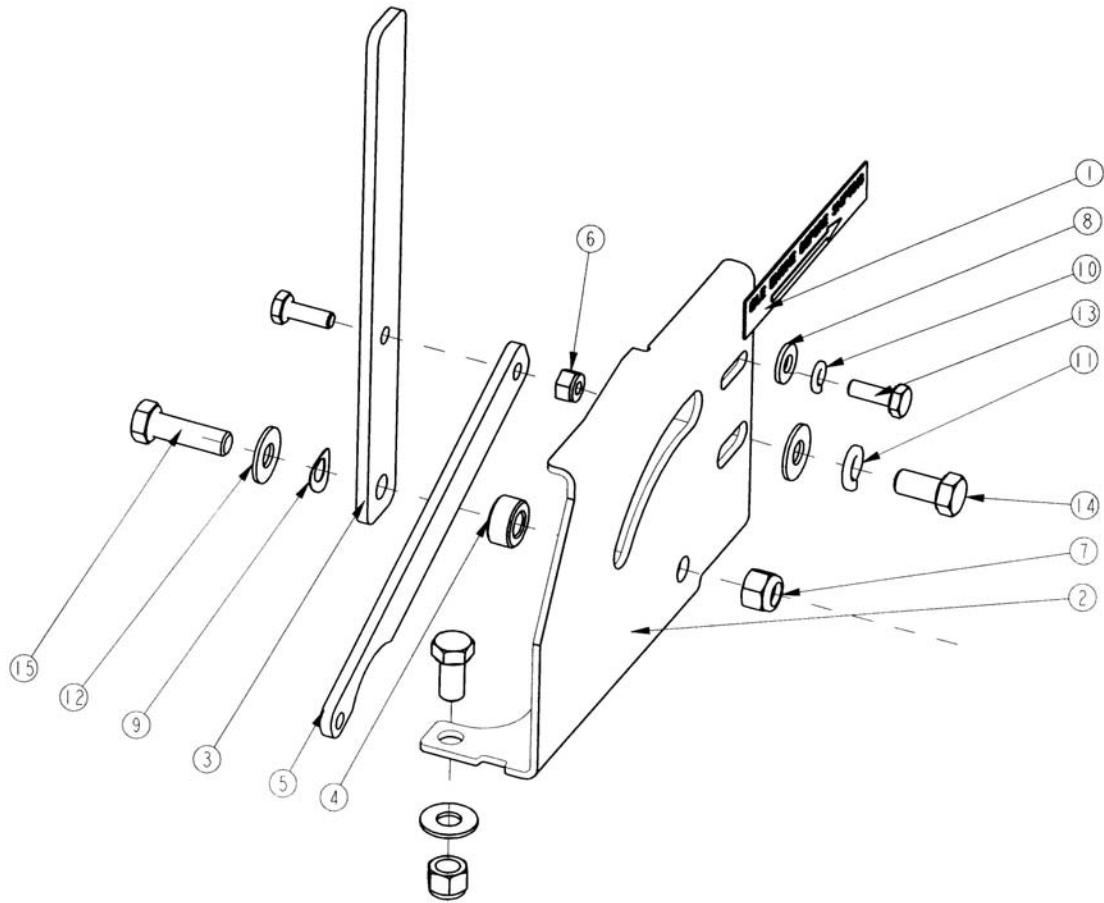

BILL OF MATERIAL - 410124			
ITEM	PART NO.	REQ'D	DESCRIPTION
1	410118	1	DECAL, DOOR
2	410120	1	LEVER PLATE
3	410121	1	BAR, DOOR CONTROL
4	410122	1	TUBE SPACER 3/8
5	410123	1	BAR, DOOR LINK
6	711373	1	NUT-NYLOC 1/4-20
7	711380	2	NUT-NYLOC 3/8-16 NUT
8	711505	1	WSR-FLAT 1/4
9	711523	1	WSR-WAVE .37X .68 X .08
10	711544	1	WSR-HELICAL 1/4
11	711546	1	WSR-HELICAL 3/8
12	712301	3	WSR-FLAT .87 X .38 X .06
13	713002	2	BLT-HH 1/4-20 UNC-2A X 3/4 STL#5
14	713041	2	BLT-HH 3/8-16 X 3/4 #5
15	713043	1	BLT-HH 3/8-16 X 1 1/4 #5

# LIMITED WARRANTY

The Parker Sweeper Company warrants to the original purchaser/user that this product is free from defects in workmanship and materials under normal use and service for a period of two years from date of purchase. In addition, Parker Sweeper Company will, at its option, honor labor warranty claims for the first 12 months from date of sale, provided such claims are submitted through and approved by factory authorized repair stations. Parker Sweeper Company will, at its option, repair or replace without charge, except for transportation costs, parts that fail under normal use and service when operated and maintained in accordance with the applicable operation and instruction manuals.

This warranty does not apply to normal wear, or to items whose life is dependent on their use and care, such as belts, cords, switches, hoses, rubber parts, electrical motor components or adjustments. Parts not manufactured by Parker Sweeper Company such as engines, batteries, battery chargers, hydraulic pumps, and tires are covered by and subject to the warranties and/or guarantees of their manufacturers. Please contact Minuteman International, Inc. for procedures in warranty claims against these manufacturers.

**Special warning to purchaser** — Use of replacement filters and/or prefilters not manufactured by Parker Sweeper Company or its designated licensees, will void all warranties expressed or implied.

A potential health hazard exists without exact original equipment replacement.

All warranted items become the sole property of Parker Sweeper Company or its original manufacturer, whichever the case may be.

Parker Sweeper Company disclaims any implied warranty, including the warranty of merchantability and the warranty of fitness for a particular purpose. Parker Sweeper Company assumes no responsibility for any special, incidental or consequential damages.

This limited warranty is applicable only in the U.S.A. and Canada, and is extended only to the original user/purchaser of this product. Customers outside the U.S.A. and Canada should contact their local distributor for export warranty policies. Parker Sweeper Company is not responsible for costs or repairs performed by persons other than those specifically authorized by Parker Sweeper Company. This warranty does not apply to damage from transportation, alterations by unauthorized persons, misuse or abuse of the equipment, use of non-compatible chemicals, or damage to property, or loss of income due to malfunctions of the product.

If a difficulty develops with this machine, you should contact the dealer from whom it was purchased.

This warranty gives you specific legal rights, and you may have other rights, which vary from state to state. Some states do not allow the exclusion or limitation of special, incidental or consequential damages, or limitations on how long an implied warranty lasts, so the above exclusions and limitations may not apply to you.



*A Minuteman International Company*

**World Headquarters**

Minuteman International, Inc.  
111 South Rohlwing Road  
Addison, Illinois 60101

Minuteman Canada, Inc.  
2210 Drew Road  
Mississauga, Ontario  
L5S 1B1

(630) 627-6900

(905) 673-3222

FAX (630) 627-1130      FAX (905) 673-5161

988235

Printed in U.S.A.

**02/05 REV A**