



INSTRUCTIONS

-J04480

REV. 2015-04-23

SCREAMIN' EAGLE "HEAVY BREATHER" PERFORMANCE AIR CLEANER KIT

GENERAL

Kit Numbers

29264-08, 29080-09

Models

For model fitment information, see the P&A Retail Catalog or the Parts and Accessories section of www.harley-davidson.com (English only).

NOTE

These kits are intended for High Performance applications only. Engine-related performance parts are intended FOR THE EXPERIENCED RIDER ONLY.

Additional Parts Required

LOCTITE® 243 (Blue) Threadlocker and Sealant is needed for proper installation of this kit. A 0.5 mL pack of Loctite 243 is included with this kit. A 6.0 mL tube (99642-97) is available from a Harley-Davidson dealer.

Air filter oil is also needed for proper installation of this kit. K&N® Air Filter Oil is available from a Harley-Davidson dealer, either alone (12.25 oz/347 gram aerosol can, 99882-88T) or in a 6.5 oz/184 gram aerosol can as part of the Filter Care Service Kit (99850-92T).

Proper installation of this kit requires breather screws (3565), which are OE equipped on 2004 and later XL models. If the motorcycle is not equipped with these breather screws, separate purchase is required.

WARNING

The rider's safety depends upon the correct installation of this kit. Use the appropriate service manual procedures. If the procedure is not within your capabilities or you do not have the correct tools, have a Harley-Davidson dealer perform the installation. Improper installation of this kit could result in death or serious injury. (00333a)

NOTES

This instruction sheet references service manual information. A service manual for your model motorcycle is required for this installation and is available from a Harley-Davidson dealer.

The following caution and note apply to EFI models only.

NOTICE

You must recalibrate the ECM when installing this kit. Failure to properly recalibrate the ECM can result in severe engine damage. (00399b)

NOTE

See a Harley-Davidson dealer for ECM (Electronic Control Module) calibration.

Kit Contents

See Figure 1 and Table 1.

INSTALLATION

WARNING

To prevent accidental vehicle start-up, which could cause death or serious injury, disconnect battery cables (negative (-) cable first) before proceeding. (00307a)

WARNING

Disconnect negative (-) battery cable first. If positive (+) cable should contact ground with negative (-) cable connected, the resulting sparks can cause a battery explosion, which could result in death or serious injury. (00049a)

1. Refer to the service manual and follow the instructions given to remove the seat and disconnect the battery cables, negative (-) cable first. Save all seat mounting hardware.

WARNING

When servicing the fuel system, do not smoke or allow open flame or sparks in the vicinity. Gasoline is extremely flammable and highly explosive, which could result in death or serious injury. (00330a)

Original Equipment (OE) Air Cleaner Removal

For carbureted models: Refer to the service manual and check the warm-slow idle speed adjustment before removing the OE air cleaner backplate.

For EFI (fuel-injected) models: Have a Harley-Davidson dealer recalibrate the ECM prior to air cleaner installation.

2. Remove the air cleaner backplate following the instructions in the service manual. Retain the two breather screws (A) removed from the backplate (see Figure 1). The remaining parts can be discarded.
3. See Figure 1. Remove and discard induction module bracket (B).

"Heavy Breather" Air Cleaner Installation

NOTE

When servicing the air cleaner, apply Loctite 243 (blue) to all threaded fasteners (both male and female threads).

4. See Figure 1. Install the **new** O-rings (4) in the grooves around the breather screw holes on the carburetor or induction module side of the backplate (1 or 2).
5. Remove the backing from the adhesive side of the backplate gasket (3). Carefully align the holes and install the gasket on the carburetor or induction module side of the backplate.
6. Insert the breather screws (removed in Step 2) through the backplate. Apply a small amount of Loctite (9) to the breather screw threads and the mating tapped holes in the cylinder head, then install the screws into the cylinder head. **DO NOT** tighten completely at this time.
7. Obtain the three backplate mounting screws (5) from the kit, and apply a small amount of Loctite to the screw threads. Install the screws all the way through the backplate and gasket until the screw threads are captured in the carburetor or induction module. **DO NOT** tighten completely at this time.
8. Alternately tighten the two breather screws to 120-144 **in-lbs** (13.6-16.3 Nm).
9. Lubricate the O-rings (6) with clean engine oil or white lithium grease.
Install the O-rings onto the breather plugs (10). Press the breather plugs into the breather screw cavities.
10. Tighten the three backplate mounting screws to 55-60 **in-lbs** (6.2-6.8 Nm).

Air Filter Element and Air Tube Installation

NOTE

This air filter is PRE-OILED and ready to install.

11. With the countersunk holes facing outward, slide the mounting ring (13) all the way onto the intake tube (12), up to the flange.
12. Place the gasket (7) against the opposite side of the flange.
13. Align the holes in the gasket with the mounting ring holes and notches in the intake tube flange.
14. Apply a small amount of Loctite to the threads of the three flat head screws (8).
15. Secure the intake tube, mounting ring and gasket to the air cleaner backplate, and tighten the screws to 55-60 **in-lbs** (6.2-6.8 Nm).
16. Remove the backing from one side of the adhesive ring (17), center the ring on the inner surface of the band clamp cover (16) and press the ring evenly and firmly into place.

17. Remove the air filter element (19) and band clamp (15) from the package. Loosen the band clamp as needed to allow removal or repositioning.

NOTES

For proper adhesion, degrease the area on the backside of the filter element where the adhesive ring will be mounted.

Note the Screamin' Eagle® logo on the chrome filter element end cap. For best appearance, install the band clamp and chrome band clamp cover onto the filter element flange so the screw slot will be accessible but the screw mechanism hidden from view when the filter is installed to the intake tube with the logo upright.

18. Remove the backing from the remaining side of the adhesive ring and press the chrome band clamp cover onto the large end of the air filter element.
Position the band clamp onto the filter element flange, inside the chrome cover flange with the band clamp screw mechanism in the cover flange cutout.
19. Install the air filter element onto the intake tube approximately 5/8 inch (16 mm). Check that the filter element end cap logo is upright, and the band clamp screw mechanism is hidden from view, yet the screw slot is accessible for tightening.
Tighten the clamp around the filter element flange to 30-40 **in-lbs** (3.4-4.5 Nm).
20. Install the rain sock (19) over the air filter element.

WARNING

Connect positive (+) battery cable first. If positive (+) cable should contact ground with negative (-) cable connected, the resulting sparks can cause a battery explosion, which could result in death or serious injury. (00068a)

21. Refer to the service manual and follow the instructions given to connect the battery cables, positive (+) cable first, and install the seat.

WARNING

After installing seat, pull upward on seat to be sure it is locked in position. While riding, a loose seat can shift causing loss of control, which could result in death or serious injury. (00070b)

NOTES

Riding a motorcycle equipped with an exposed oiled air filter under rainy conditions IS NOT RECOMMENDED.

Install the rain sock (19) over the air filter element under these circumstances.

AIR FILTER ELEMENT MAINTENANCE

NOTES

Riding a motorcycle equipped with an exposed oiled air filter under rainy conditions IS NOT RECOMMENDED.

Install the rain sock (19) over the air filter element under these circumstances.

1. Inspect the air filter element every 5000 miles (8000 km), or more often under dusty conditions.

NOTES

The use of cleaning, drying or oiling methods or products other than those shown will damage the filter and void the manufacturer's warranty.

K&N® Air Filter Cleaner is available from a Harley-Davidson dealer, either alone (1 qt./0.95 L sprayer bottle, 99883-88T) or a 12 fl oz/0.35 L sprayer bottle as part of the Filter Care Service Kit (99850-92T).

K&N Air Filter Oil is also available from a Harley-Davidson dealer, either alone (12.25 oz/ 347 gram aerosol can, 99882-88T) or a 6.5 oz/ 184 gram aerosol can as part of the Filter Care Service Kit.

DO NOT OVER-OIL THE AIR FILTER. Over-oiling may interfere with the proper performance of the engine and/or certain engine components. If oil is still draining or dripping from the filter media twenty minutes after oiling, clean and oil the filter element again.

2. To clean the element:
 - a. Loosen the hose clamp retaining the air filter element assembly to the air tube. Separate the element from the air tube.
 - b. Tap the element to dislodge any loose dirt, then gently brush with a soft bristle brush.
 - c. Spray air filter cleaner liberally onto the cotton filter media and let soak for ten minutes, OR roll or soak the cotton filter media in a shallow pan of air filter cleaner. Remove immediately, and let soak for ten minutes.
 - d. Rinse off the filter media (flowing from the **clean** side to the dirty side), with low-pressure tap water.
 - e. After rinsing, shake off all excess water, and let the filter media air dry. DO NOT use compressed air or a heat gun to speed drying.
 - f. After the filter media is **completely** dry, EITHER spray air filter oil along each pleat, once only, holding the spray nozzle approximately 3 inches (76 mm) away from the media, OR carefully use a squeeze bottle to deposit oil along each pleat, once only.
Let the oil absorb into the filter media for twenty minutes before proceeding.
After twenty minutes, inspect the filter media, and carefully apply oil to any remaining visible white spots on the filter media, and allow to absorb.
3. Install the air filter element onto the intake tube approximately 5/8 inch (16 mm). Check that the filter element end cap logo is upright.
Tighten the clamp around the filter element flange to 30-40 **in-lbs** (3.4-4.5 Nm).

SERVICE PARTS

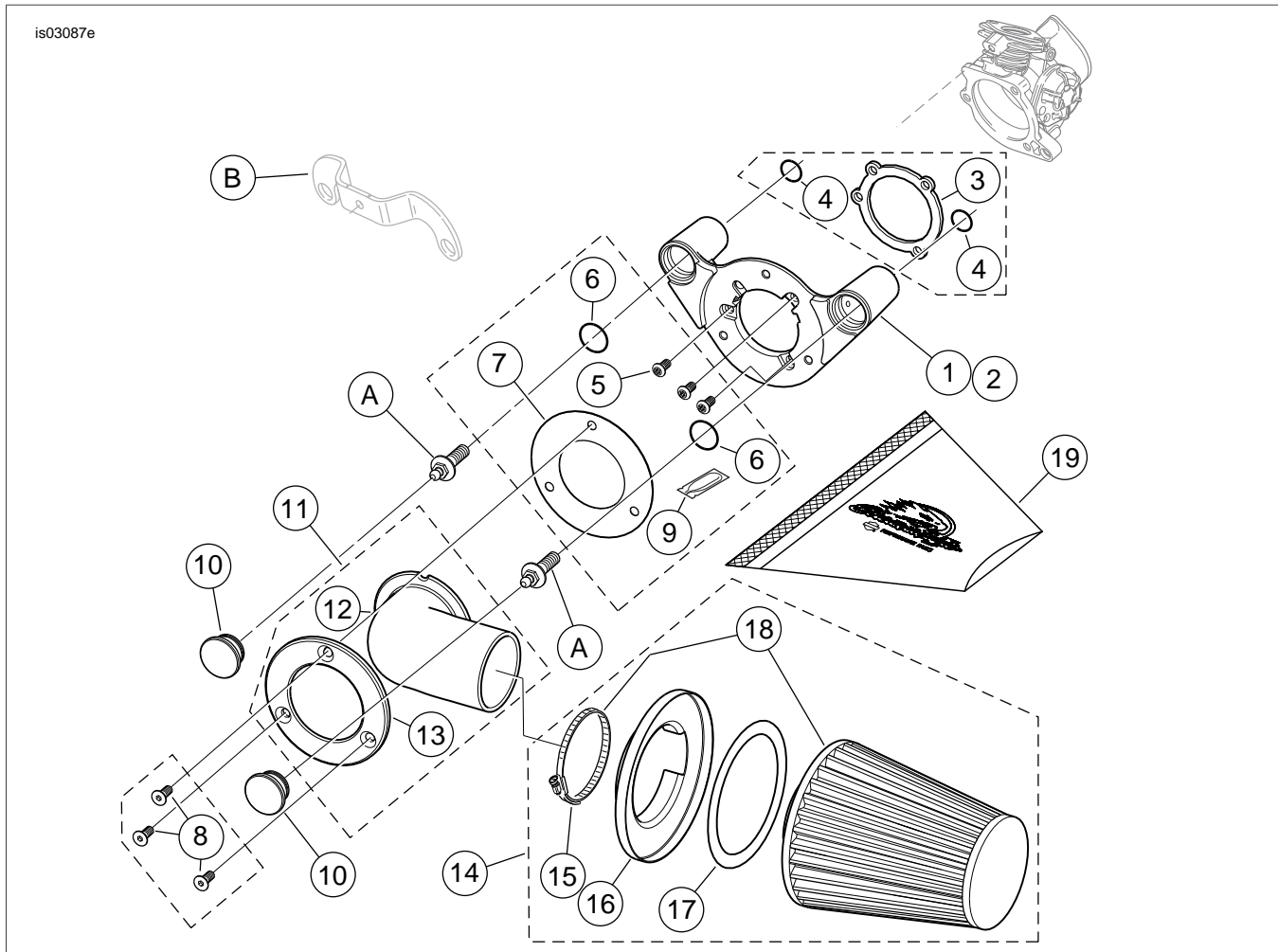

Figure 1. Service Parts: Air Cleaner Kit

Table 1. Service Parts Table

Item	Description (Quantity)	Part Number
1	Backplate, air cleaner , chrome	29760-05
2	Backplate, air cleaner , black	28888-09
3	Gasket, backplate to carburetor or induction module	29059-88A
4	O-ring, backplate (2)	11292
5	Screw, backplate mounting (3)	926
6	O-ring, breather plug (4)	10925
7	Gasket, intake tube to backplate	29593-05A
8	Screw, flat head (3)	2986
9	Loctite 243 (blue) Threadlocker and Sealant (0.5 mL tube)	94635-98
10	Plug, breather (2)	29830-05A
11	Intake tube and mounting ring service kit, chrome only (includes items 12 and 13)	29571-08
12	• Intake tube, chrome	Not sold separately
	Intake tube, black	28817-09
13	• Mounting ring, chrome	Not sold separately
	Mounting ring, black	29070-09
14	Air cleaner filter kit (includes items 15 through 19)	29424-05A

Table 1. Service Parts Table

Item	Description (Quantity)	Part Number
15	• Band clamp	Not sold separately
16	• Cover, band clamp (chrome)	Not sold separately
17	• Adhesive ring	Not sold separately
18	• Element, air filter (includes item 15)	Not sold separately
19	Rain sock, air filter	29493-05
Items mentioned in text, but not included in kit:		
A	Original equipment breather screw (2)	
B	Induction module bracket (remove and discard)	