



MOOSE RACING

EXPEDITION LUGGAGE ADVENTURE PANNIER MOUNT SET



INCLUDES EVERYTHING YOU NEED TO ADD MOUNTS TO YOUR MOTORCYCLE
3501-0910 BMW R1100/1150GS: 1999 - 2005

FEATURES OF THE EXPEDITION LUGGAGE - ADVENTURE PANNIER MOUNT SET:

- Rugged 18mm steel tube mounting hoops and arms rigidity secure the luggage to your motorcycle
- Precision machined brackets ensure proper fit and durability
- Deep, complete welds make sure the mounts can handle the rigors of Adventure Touring
- Thick, black-matte powder-coating looks as good as it is tough
- Includes high-quality, cad-plated hardware with flange-style bolt heads and flange-style locking nuts
- Designed to work perfectly with MOOSE Expedition Aluminum Panniers
- No motorcycle modification required, simple installation - Designed and built in the U.S.A.

⚠ WARNING

READ THESE INSTRUCTIONS THOROUGHLY BEFORE INSTALLATION!

Because of the variety of motorcycle configurations, other accessories, and the features and intended use of this MOOSE accessory, there are many different mounting options. You are responsible for the proper installation of this accessory on your motorcycle. Download the required instructions for your accessory mount set and motorcycle from www.MOOSERACING.com. Your attention to the installation instructions and recommendations will permit safe and proper use of this accessory. You must mount this accessory properly and securely before riding your motorcycle. If you lack the ability to safely and properly install this accessory, seek out a qualified motorcycle technician for assistance. During installation, support the motorcycle with a suitable stand or lift so it will not tip over and injure you, or damage the vehicle. Using or mounting this accessory improperly could result in a loss of control of the motorcycle which could result in damage to your motorcycle or other personal property, the property of third parties, and/or personal injury to yourself or others, up to and including death.

BE SURE TO THOROUGHLY READ AND CLOSELY FOLLOW THE MOUNTING INSTRUCTIONS THAT ARE INCLUDED WITH THIS ACCESSORY:

- The pannier mounts must be installed and securely fastened to the motorcycle's frame.
- Install the mounts securely so they will not shift or move while riding. Make sure the mounts and all related brackets and hardware will not contact the wheels, suspension or any other moving parts of the motorcycle.
- If you do not understand these instructions DO NOT install the mounts. Remove any components you may have already installed on your motorcycle.
- Thoroughly inspect your motorcycle's luggage mounts and panniers before every ride.
- Do not use the panniers if the mounts have been modified, or if they have deteriorated, loosened, cracked, or are beginning to fail in any way. Do not use the panniers or mounts if your motorcycle's frame is damaged, or if the sub-frame is damaged or is loose on the main chassis.
- Check the security of the mounts at each stop as you ride. Mounting hardware can loosen during operation, so be sure to check it frequently.
- Do not use this accessory mount set if you have any doubts as to whether it is properly mounted to your motorcycle.
- Do not exceed 25 pounds (11.3 kg) of cargo in each pannier bag you attach to your mounts - 50 pounds total (22.6 kg total).
- When using this accessory, do not exceed your vehicle's Maximum Gross Vehicle Weight as listed on your motorcycle or in its Owner's Manual.
- Be aware the panniers and cargo will affect your vehicle's performance and handling characteristics. Use caution when riding your motorcycle.
- Balance your cargo evenly between each pannier and arrange its placement so it does not shift during riding.
- When riding with panniers mounted to your motorcycle, be aware the width of your luggage may exceed the width of your handlebars. Use extra care when maneuvering in traffic or around other obstacles so you do not impact other objects with your luggage.
- If you strike another object, or tip over your motorcycle, immediately inspect the panniers, their mounts and your vehicle for damage.
- If your panniers or mounts are ever damaged, do not use them until they have been inspected by your local professional motorcycle dealer. Replace these parts immediately if they have damage that will prevent them from being properly secured to your motorcycle or able to securely hold cargo.

DO NOT ATTEMPT TO USE THIS ACCESSORY IF:

- You do not understand these installation and use instructions,
- You do not understand any part of the accessory mounting system,
- You have any doubts as to the security of the mounting system.

If you have any concerns or questions, contact your authorized MOOSE retailer.

Remember: Motorcycling can be a dangerous activity. Installation of any accessory can increase your risk if it is not installed properly. You are responsible to install this accessory so it will not contact any portion of the drive train, suspension or steering, and so that it will in no way interfere with the operation of your motorcycle.

RECOMMENDED TOOLS & MATERIALS:

| | | |
|--|--|---------------------------------------|
| 12mm wrench or socket (may need two) | 13mm wrench or socket (may need two) | 10mm wrench or socket (may need two) |
| Allen wrench or driver tool set (various sizes required) | Torx-driver tool set (various sizes required for BMW hardware) | #3 Phillips screwdriver |
| Power drill (up to 1/2" chuck) | 5/16" & 1/4" drill bits | Center punch |
| Deburring tool (or 1/2" drill bit) | Masking tape & pen | Shop vacuum |
| Required: Vinyl electrical tape | Required: Thread Locking Agent | Suggested: Double-sided adhesive tape |

NOTE: Other tools may be required, depending upon your vehicle, previously installed accessories, and how you will mount this accessory.

Continued on next page...



WWW. MOOSERACING.COM 1 / 8

ITEMS INCLUDED WITH YOUR EXPEDITION PANNIER MOUNTS:

| Mount parts | Qty. | Pannier attachment hardware | Qty. | Pannier attachment hardware | Qty. |
|---|------|-----------------------------------|------|-------------------------------------|------|
| Left-hand pannier mount | 1 | Buffer/drill templates | 2 | Support discs (3" dia) | 4 |
| Right-hand pannier mount | 1 | Mounting lip | 2 | Washers (1.5" dia) | 4 |
| Back support bar | 1 | Mounting lip buffer strips | 2 | Washers (1.25" dia) | 4 |
| Spacer plate (with two 7mm holes) | 2 | Button-head bolt (6 x 16mm) | 8 | Rubber washer (1.5" dia) | 4 |
| Spacer (8mm ID, 5mm L) | 2 | Nylock flange nut (6mm) | 8 | Instruction sheet (not shown) | 1 |
| Spacer (8mm ID, 12mm L) | 3 | Flange bolt (8 x 30mm) | 4 | | |
| Flange bolt (8 x 30mm) | 5 | Nylock flange nut (8mm) | 4 | | |
| Flange bolt (8 x 25mm) | 4 | | | | |
| Flange bolt (8 x 20mm) | 1 | | | | |
| Flange bolt (6 x 20mm) | 4 | | | | |
| Button-head Allen bolt (6 x 22mm) | 2 | | | | |
| Lock nut (6mm) | 4 | | | | |

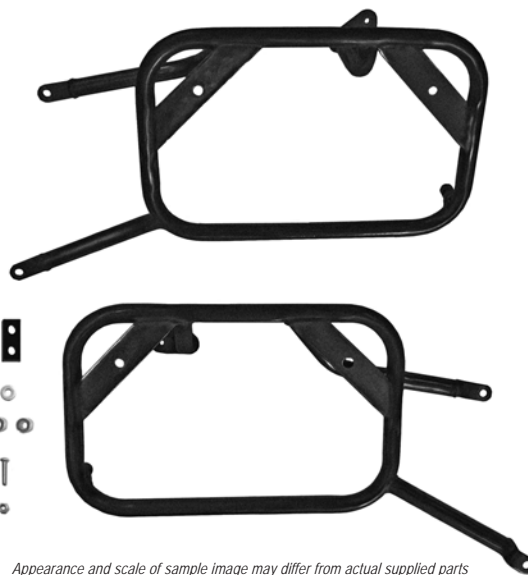
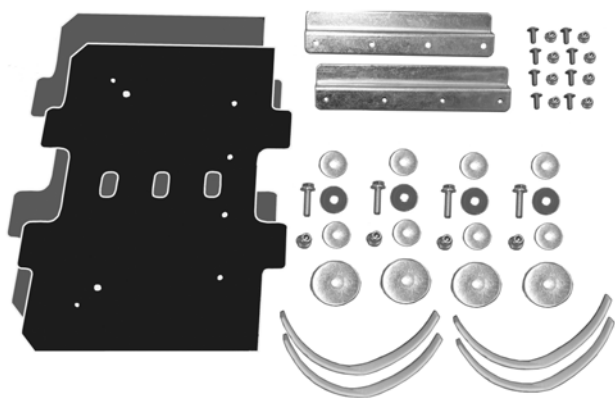

Appearance and scale of sample image may differ from actual supplied parts

INSTALLATION INSTRUCTIONS:

Your MOOSE pannier mounts were developed to mount easily to BMW R1100GS or R1150GS motorcycles in stock trim. Before beginning, have your motorcycle's Owner's Manual and Service Manual handy in case you need to reference a procedure.

STEP 1 - WARNING: Place the motorcycle ① on it's center-stand, or a secure service stand, so it will not tip over and injure you, or cause damage to the vehicle itself. Perform the work on a cool motorcycle to prevent burns. Enlist the aid of a helper when installing the mounts as some steps require holding components while a fastener is being installed. If you lack the technical understanding or ability to install the pannier mounts, seek out the assistance of a qualified motorcycle technician.

NOTE: Save any removed hardware so you can return the motorcycle to its original configuration if you decide to remove the pannier mounts. If your motorcycle is equipped with other aftermarket pannier mounts, that hardware may need to be removed.

Remove the seats (refer to the procedure in your owner's manual). Remove the left and right passenger peg assemblies ② from the hoops on the sub-frame. Set the peg assemblies aside as they will be reinstalled in STEPS 5 & 6. Move to STEP 3.

STEP 2: Hold the left pannier mount to the motorcycle and insert two of the supplied 6 x 20mm flange bolts ③ through the top, rear mounting tab holes ④, through the supplied twin-hole spacer plate ⑤ and hand thread the bolts into the threaded holes in the sub-frame ⑥. Repeat this procedure with the right mount on the other side of the motorcycle.

WARNING: Always apply a thread-locking agent to the threads of the bolts and nuts as you install the hardware. Do this to the new hardware and original fasteners you reinstall as part of the mount installation procedure. See page 8 of this instruction set for the type of recommended thread locking agent.

CAUTION: Do not tighten any mounting hardware fully until all of the mount set components are loosely assembled together on the motorcycle.

Move to STEP 3.

STEP 1



STEP 2

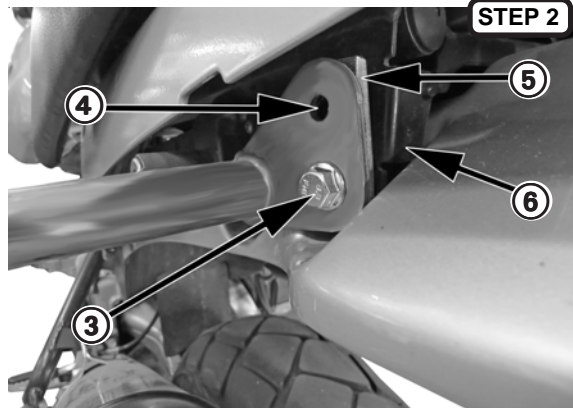

Continued on next page...

INSTALLATION INSTRUCTIONS *(continued)*:

STEP 3: Insert the supplied 8 x 20mm flange bolt ① through the top, left pannier mount tab ② and into the threaded hole in the sub-frame. Turn the bolt in about halfway, do not tighten it fully.

CAUTION: As you will be working near the exhaust system, you can apply a protective medium (such as protective tape) to the silencer's surface. If you apply any protective material to the exhaust, be sure to remove it before operating the engine.

WARNING: Do not touch or apply any tape to exhaust system components unless the motorcycle is cool (the engine has not been run for a hour or more).

REMINDER: Do not tighten any mounting hardware fully until all of the mount set components are loosely assembled together on the motorcycle. This will ensure all of the components mesh together and further permits you to make aesthetic adjustments. Always use care during installation so you don't cross thread fasteners.

Move to STEP 4.

STEP 4: Insert one of the supplied 8 x 30mm flange bolts ③ through the top, right pannier mount tab ④ through one of the supplied 12mm thick spacers ⑤ and into the threaded hole in the sub-frame. Turn the bolt in about halfway, do not tighten it fully.

REMINDER: Always apply a thread-locking agent to the threads of the bolts and nuts as you install the hardware. See page 8 of this instruction set for the type of recommended thread locking agent.

Move to STEP 5.

STEP 5: Your MOOSE pannier mount kit is supplied with a variety of spacers and bolts to connect the pannier mounts between the hoops on the sub-frame ⑥ and the passenger peg assemblies removed in STEP 1. Using the spacers and longer bolts is required to provide clearance between the passenger peg assembly and the pannier mount arm.

Most R1100/1150GS motorcycles require one of the supplied 12mm thick spacers ⑦ to be put in place at the front threaded tab of the hoop. The pannier mount arm ⑧ and one of the supplied 5mm thick spacers will be put in place at the rear mounting hole. Use two of the supplied 8 x 30mm flange bolts to reattach the passenger peg assembly outside of the pacers and the mount arm, and then into the mounting hoop. Turn the bolts in about halfway, do not tighten them fully.

Repeat this procedure on the other side of the motorcycle.

Move to STEP 6.

STEP 6: Some R1100GS motorcycles require a different amount of spacing. Hold the passenger peg assembly up to the mounting hoop ⑨ to see if less clearance is required.

If less clearance is required, place one of the supplied 5mm thick spacers ⑩ at the front threaded tab of the hoop. The pannier mount arm ⑪ without a spacer will be put in place at the rear mounting hole. Use two of the supplied 8 x 25mm flange bolts to reattach the passenger peg assembly outside of the spacer and mount arm and then to the mounting hoop. Turn the bolts in about halfway, do not tighten them fully.

Repeat this procedure on the other side of the motorcycle.

Move to STEP 7.

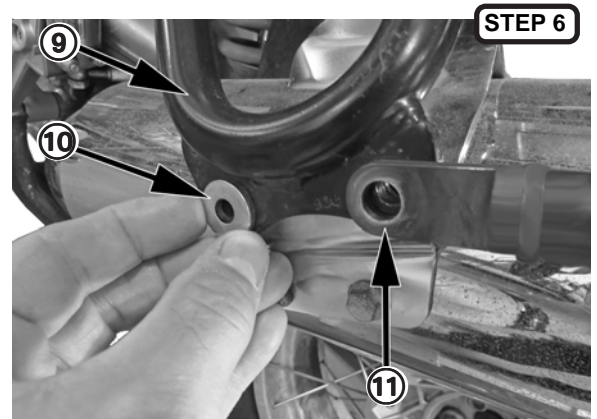
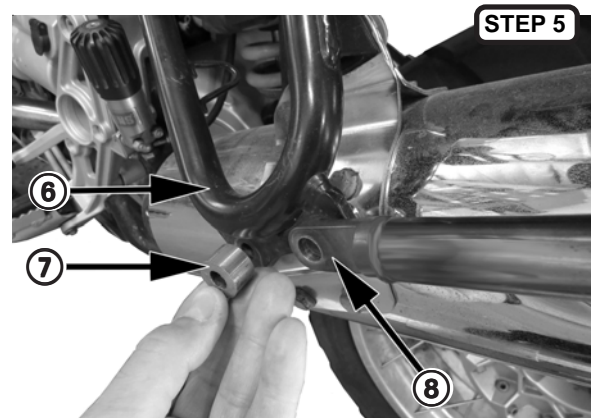
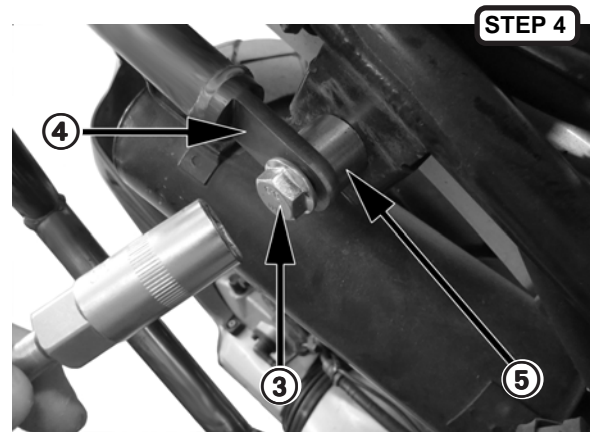
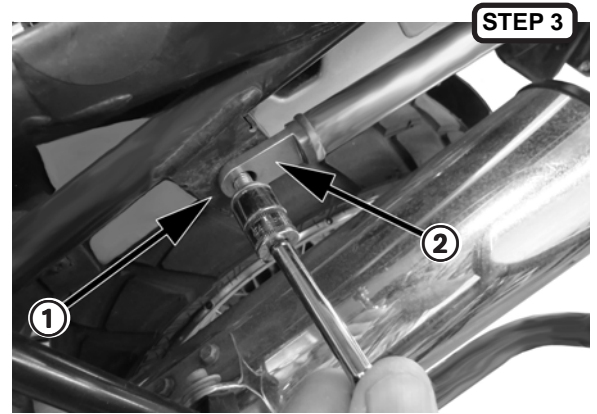

Continued on next page...

INSTALLATION INSTRUCTIONS (continued):

STEP 7: With the left and right mounts loosely in place, install the back support bar ① onto the machined nipples on each mount ②. Insert the supplied 6 x 22mm button-head Allen bolts and 6mm locking nuts through the holes in the bar and the nipples on the mounts. Rotate the bar so the holes ③ align. Orient the hardware so the bolt heads face outward. Prepare to tighten ALL of the hardware fully.

NOTE: If the back support bar will not easily connect to the nipples, remove one side of the pannier mount, slip the bar on both mounts and reinstall the mount.

IMPORTANT ASSEMBLY NOTE: Verify that all of the mounting hardware is installed on the mounts and the motorcycle's chassis. Make sure all of the fasteners are threaded properly into their respective nuts or mounting points and thread lock has been applied. Check to make sure the mounts are aligned properly on the motorcycle and then begin to tighten all of the hardware to the torque specifications listed in the *Hardware Torque Value* table on page 8 of this instruction set.

REMINDER: Remove any protective tape from the exhaust silencer. Reinstall the seats per the procedure outlined in your motorcycle's Owner's Manual.

You will now need to prepare your panniers for attachment to the mounts. Move to STEP 8.

STEP 8: Supplied with your pannier mounts are a pair of plastic buffer/drill template sheets. These sheets have been engineered to mate perfectly with the outer wall contours of the MOOSE Expedition Panniers. You will use the sheets to mark the location of the holes you will need to drill in the panniers to install the mounting hardware supplied in this kit. After the holes are drilled and cleaned, the plastic sheets are then attached to the panniers to help protect the luggage and the mounts from abrasive wear.

NOTE: The beveled corners ④ indicate the TOP of the buffer/drill templates.

DRILL BIT SIZES REQUIRED: Refer to the template illustration at right and sizes listed below to select the proper size drill bits required to place holes in your panniers for the mounting kit hardware.

- ⑤ This hole is not used for these mounts **DO NOT DRILL**
 - ⑥ Use a 5/16" drill bit for the upper 8mm mounting hardware
 - ⑦ Use a 1/4" drill bit for the 6mm hardware that retains the lower mounting lip
- NOTE:** Use a 1/2" drill bit or a formal tool to deburr holes after they have been drilled

Move to STEP 9.

STEP 9: Set your pannier box down on a protected surface (with the lid removed) and place the buffer/drill template on the side that will face the motorcycle's chassis. This is the side of the pannier that has the riveted joint. The buffer/drill template's shape determines its placement on the pannier. The angular edges ⑧ indicates the top of the buffer/template. The buffer/template's other shapes fit with the pannier's bumpers ⑨ and there is clearance for the protruding rivet heads ⑩.

NOTE: You can use other band panniers with your MOOSE pannier mounts. While the buffer/drill template shapes will not exactly match another brand pannier, the hole relationships will allow you to attach the mounting hardware so the luggage can attach to the pannier mounts. Use care when selecting the mounting methods for non-MOOSE panniers on the mounts.

Move to STEP 10.

STEP 10: Position the buffer/template so it aligns with the contours and edges of the pannier. Use some masking tape ⑪ to temporarily hold the buffer/template in place for marking the drill hole locations.

Move to STEP 11.

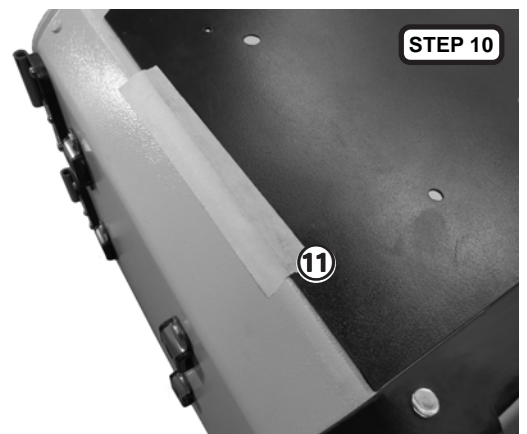
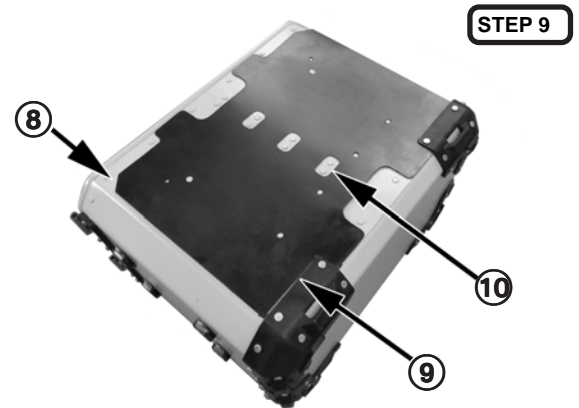
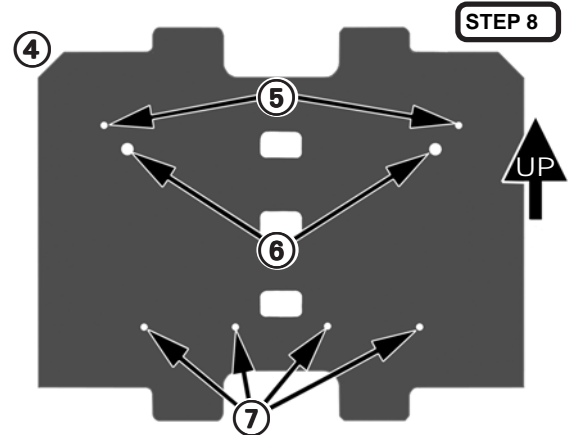
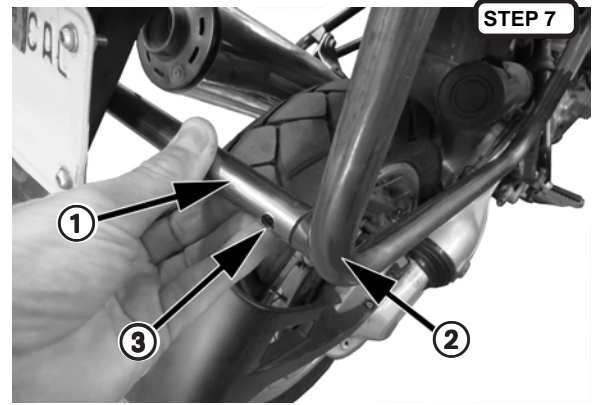

Continued on next page...

STEP 11: Use a pencil to mark the center of the mounting holes in the pannier.

TIP: Avoid using a permanent marker or paint pen to mark the drill locations. This is so you can clean off a mark if needed. For dark color panniers, you can use a white grease pencil.

Move to STEP 12.

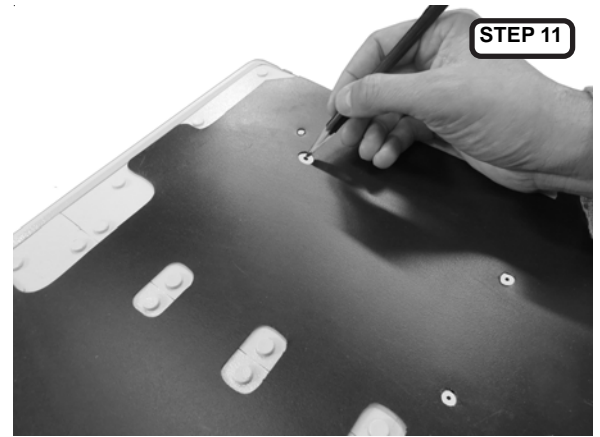

STEP 12: Remove the buffer/template from the pannier and use a center punch tool to create a pilot dent in the surface of the aluminum.

CAUTION: Use a spring-loaded center punch tool to create the indentation. Avoid using a solid punch with a hammer or another method which could cause you to dent or scratch the surface of the pannier.

Move to STEP 13.

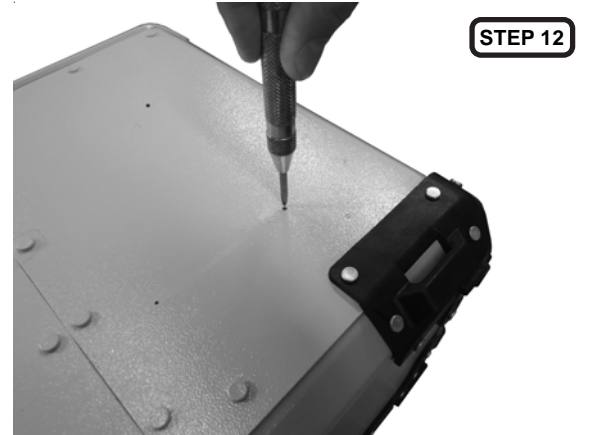

STEP 13: Using the proper size drill bit, carefully drill each of the required holes.

REMINDER: Refer to the drill bit/hole size list on page 4 (STEP 8) of this instruction set.

Move to STEP 14.



STEP 14: Hand-turn a large drill bit (1/2") or use a formal deburring tool to remove any burrs or loose material from the drilled holes.

CAUTION: Deburr the exterior of the holes and the inside of the holes. Use a shop vacuum to clean up the drilling debris from the inside of the pannier. Take care to keep your work area clean of aluminum chips or other debris that could damage the pannier's finish.

After the holes are deburred, and the debris cleaned off the pannier, re-tape the buffer/template back into place.

Move to STEP 15.

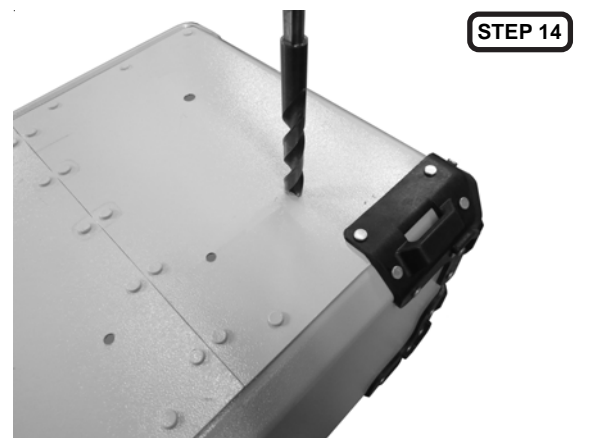

Continued on next page...

STEP 15: Prep the two mounting lips included with your pannier mounts by installing the 1/8" thick buffer strips on each lip as show ①. Once you peel the protective backing off, carefully place the strips on each lip and press firmly so they will stick in place.

TIP: You may need to trim the supplied buffer strips, so verify the length before removing the protective backing from the strip.

The majority of the water resistance designed into your pannier mounting components is from the plastic buffer/drill template and the Nylock-style nuts that hold the mounting lip in place on each pannier. For additional sealing apply some silicone sealant to the threads ② and underside of the head ③ of the eight 6mm button-head screws supplied with your mounts.

NOTE: The sealant will not compromise the fastening capability of your hardware.

Move to STEP 16.

STEP 16: Place the mounting lip on the bottom of the pannier so it's four mounting holes align with the line of four holes you drilled into the pannier. Make sure the lip is oriented so its opening is facing down ④.

Insert the 6mm button head screw through the holes inside the pannier. Use a 10mm wrench ⑤ or socket to tighten the nuts ⑥ as you hold the screws ⑦ with a #3 Phillips screwdriver ⑧. Repeat on the other pannier.

CAUTION: Tighten all of the hardware evenly. After the initial tightening of the hardware, refer to the table on page 8 for final torque specification.

Move to STEP 17.

STEP 17:

TIP: If you will be removing and reinstalling your panniers frequently, install some double sided tape at the indicated locations ⑨ between the outer wall of the bag and the plastic protector. This will ease mounting as it will prevent the protector from flaring away from the pannier.

NOTE: Obtain the double-sided adhesive tape from your local hardware store.

Move to STEP 18.

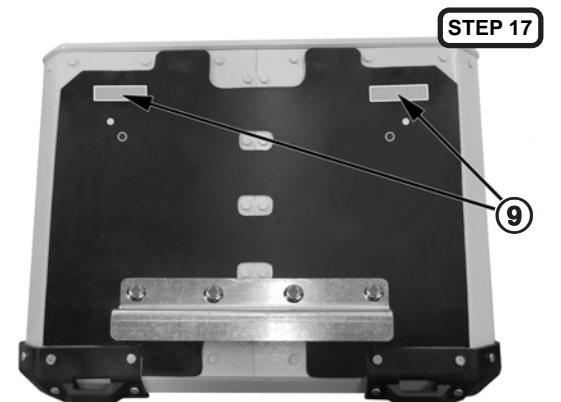
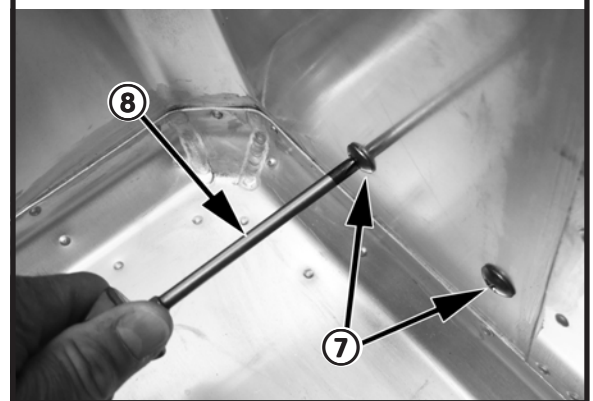
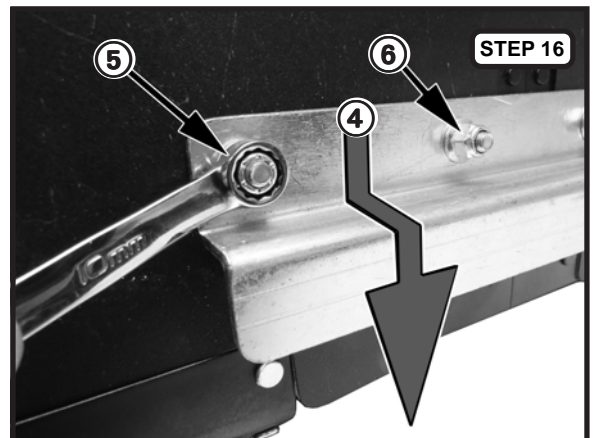
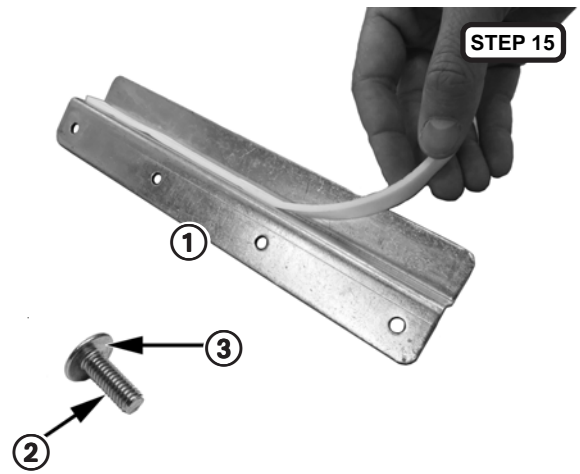

Continued on next page...

STEP 18: Each pannier is secured to the mount assembly via the bottom mounting lip and the hardware that connects it to the brackets in the top corners of the mount's rectangular hoop. Familiarize yourself with the hardware and lay it out in the order that is used to attach the pannier to the mount:

| <i>Item</i> | <i>Description</i> | <i>Qty. (per pannier)</i> |
|-------------|--------------------------|---------------------------|
| ① | Flange bolt (8 x 30mm) | 2 |
| ② | Washer (1.5" dia) | 2 |
| ③ | Rubber washer (1.5" dia) | 2 |
| ④ | Support disc (3" dia) | 2 |
| ⑤ | Pannier/protector | - |
| ⑥ | Mount bracket | - |
| ⑦ | Washer (1.25" dia) | 2 |
| ⑧ | Nylock flange nut (8mm) | 2 |

TIPS: Enlist the aid of another person when mounting the panniers. Once you are familiar with the mounting process you can easily do it by yourself. Pre-install the washers (in the proper order) that go on the flange bolts before attempting to mount the pannier.

With the lid off of the pannier, carefully lift it up and position it so the mounting lip slips over the bottom porting of the mount's rectangular hoop. Adjust the pannier's position so you can insert the bolt through the washers, then through the hole in the pannier's wall and the mount bracket. Slip the washer onto the protruding end of the bolt and hand thread the Nylock nut onto the bolt. Hand install the hardware in the other corner of the pannier/mount.

Using the proper wrench and/or socket, tighten both bolts ① and nuts ⑧ in each pannier. Repeat for the other pannier.

CAUTION: Tighten all of the hardware evenly. After the initial tightening of the hardware, refer to the table on page 8 for final torque specification.

Move to STEP 19.

STEP 19:

OPTIONAL ITEMS AVAILABLE: You can obtain a pannier attachment kit which includes hardware that permits pannier removal and installation without tools. See your MOOSE dealer to order part number 3501-0995.

CAUTION: Be sure to follow the instructions included with the optional quick-release kit. You must use hardware from your main mounting kit in addition with the threaded knob and clips supplied in the kit. When riding over rough paved roads, or unimproved terrain, or with a heavy cargo load you should always use the supplied, standard mounting bolts and locking nuts. This hardware will properly secure your panniers to the mounts during this type of use.

Move to STEP 20.

STEP 20:

Visually inspect the panniers to verify they are mounted evenly and away from any other components on the motorcycle. Before riding do a complete review of the installation. Do not load the panniers with cargo during an initial test ride. Install the pannier lids and latch them securely. After your test ride, double check the installation.

WARNING: Review all of the information on page 8 of the instruction set. It is imperative that you continually verify the security and integrity of your accessory and its mounting on your motorcycle. Adventure and Dual Sport motorcycles are very capable vehicles and they can operate in environments that will tax any mechanical device. Your safety and that of others is dependent on your attention to this continual inspection of your vehicle and it's accessories.

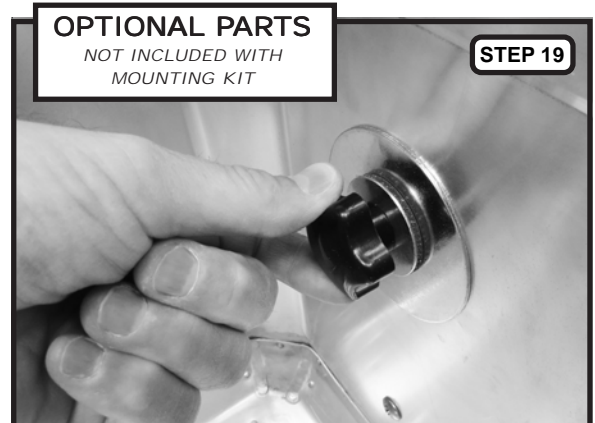
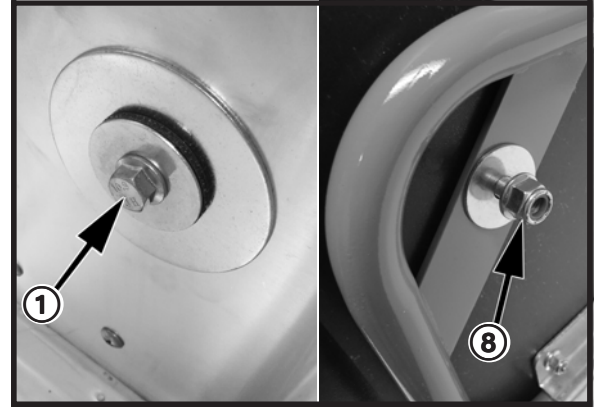
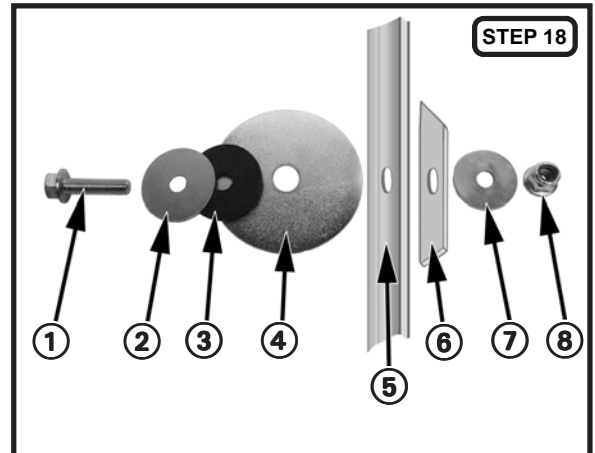

Continued on next page...

HARDWARE TORQUE VALUES:

As the final step of the pannier mount installation process, you must tighten all of the new hardware and any other related hardware on your motorcycle.

These fasteners should be tightened to the torque values specified in your vehicle's Owner's Manual and Service Manual. For fasteners not listed in those manuals, refer to the torque table below. Threads should be treated with a thread locking agent before installation.

| | | |
|------------------------------|---------------|-------------------|
| 5mm screw | 3 - 4 ft-lb | (0.35 - 0.5 kg-m) |
| 5mm bolt & nut | 3 - 4 ft-lb | (0.35 - 0.5 kg-m) |
| 6mm screw | 5 - 8 ft-lb | (0.7 - 1.1 kg-m) |
| 6mm bolt & nut | 6 - 9 ft-lb | (0.8 - 1.2 kg-m) |
| 6mm flange bolt & nut | 7 - 10 ft-lb | (1.0 - 1.4 kg-m) |
| 8mm bolt & nut | 13 - 18 ft-lb | (1.8 - 2.5 kg-m) |
| 8mm flange bolt & nut | 14 - 21 ft-lb | (2.0 - 3.0 kg-m) |
| 10mm bolt & nut | 22 - 29 ft-lb | (3.0 - 4.0 kg-m) |
| 10mm flange bolt & nut | 22 - 29 ft-lb | (3.0 - 4.0 kg-m) |
| 12mm bolt & nut | 36 - 43 ft-lb | (5.0 - 6.0 kg-m) |

Most of the supplied fasteners are flange-type; please pay attention to the different torque specifications this hardware. The majority of the nuts supplied with your mount set are self-locking type. However it is still recommend to use a locking agent on all bolt and nut threads. **Suggest the use of Three Bond Hi-Strength Thread Lock (obtain #TB-1303 or an equivalent from your MOOSE dealer).**



Round out your Adventure luggage with a MOOSE Top Case and Mounts. See your PARTS UNLIMITED dealer or check out the products on www.mooseracing.com.

MAXIMUM LOAD CAPACITY: 25 lbs (11.33 kg) per mount side/pannier

While your pannier mount set has been designed to tolerate the rigors of touring use, care must be taken to not overload your luggage system and your vehicle. Include the weight of the mounts and panniers when calculating the amount of cargo you will be carrying on your motorcycle. Do not exceed your vehicle's Maximum Gross Vehicle Weight as listed on your motorcycle or in its Owner's Manual.

IMPORTANT:

Failure to install this accessory properly may allow portions of the mounts, mounting hardware or panniers to come into contact with the motorcycles's moving parts or controls. It is vital that you verify that neither the accessory, nor any of its parts can touch, or interfere with, other motorcycle components while the steering or suspension moves through its entire range of motion. Make sure that neither your panniers, their mounts or any related hardware can come into contact with the exhaust or any other component of the motorcycle, as other vehicle components may be damaged by contact with this accessory.

It is your responsibility to make sure the installation of this accessory does not create an unsafe or illegal condition.

Check to be sure that all lights and safety reflectors are visible once the mounts and panniers are in place. If the panniers of the mounts block any side reflectors, place reflectors on the exterior sides of the panniers (reflectors with self-adhesive backing are available from motorcycle or automobile supply stores).

After 50 miles (80 kilometers) of riding, recheck the panniers and mounts to make sure that they are still tight and secure. Inspect the accessories more often if you are riding your motorcycle in wet or rough conditions (such as a dirt road). Inspect the accessory and related hardware before and during each ride. Loose accessory and/or mounting hardware can interfere with the vehicle's operation and cause an unsafe riding condition.

CARE OF YOUR MOOSE EXPEDITION PANNIER MOUNTS:

Check the attachment and assembly hardware often; tighten these fasteners as recommended in this instruction set and as listed in your vehicle's owner's manual. Your MOOSE mounts require almost no cosmetic maintenance, other than periodic cleaning with mild soap and water. It is normal for some scuffing of the mounts finish to occur, especially if you operate your motorcycle in dusty, wet or dirty conditions. This type of wear is normal and is not considered a defect, so repair or replacement of parts due to this type of surface wear is not covered under the product's limited warranty. You can use paint to cover such wear so the metal does not rust or corrode.

MOOSE LIMITED ONE-YEAR WARRANTY

MOOSE warrants this product for defects in materials, design or workmanship for a period of one year after retail purchase. Items that are defective will be repaired or replaced by MOOSE at its sole discretion. Damage caused by improper use or improper installation is not a defect; therefore repair or replacement of a damaged accessory will not be covered under this warranty. This warranty contains other provisions and conditions, so please visit www.mooseracing.com for additional information. Thank you for purchasing your MOOSE Expedition Pannier Mounts. You can count on MOOSE's quality, innovation, service and style. We want you to be completely satisfied. If you have any comments, or are not satisfied with the performance of your accessory, please contact your MOOSE retailer directly.