

QUADRA-FIRE®

CB1200-I PELLET INSERT

Owner's Manual Installation and Operation

Model:
CB1200I-B

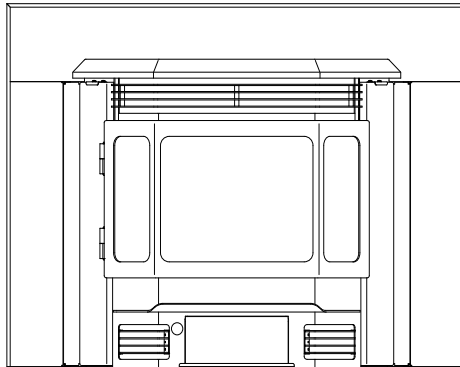

Tested and Listed by **OTL** Beaverton Oregon USA
C **UL** US
OMNI-Test Laboratories, Inc.



CAUTION



DO NOT DISCARD THIS MANUAL

- Important operating and maintenance instructions included.
- Read, understand and follow these instructions for safe installation and operation.
- Leave this manual with party responsible for use and operation.



WARNING



Please read this entire manual before installation and use of this pellet fuel-burning room heater. Failure to follow these instructions could result in property damage, bodily injury or even death.

- Do not store or use gasoline or other flammable vapors and liquids in the vicinity of this or any other appliance.
- Do not overfire - If any external part starts to glow, you are overfiring. Reduce feed rate. Overfiring will void your warranty.
- Comply with all minimum clearances to combustibles as specified. Failure to comply may cause house fire.

WARNING



HOT! DO NOT TOUCH. SEVERE BURNS MAY RESULT. CLOTHING IGNITION MAY RESULT.

Glass and other surfaces are hot during operation and cool down.

- Keep children away.
- CAREFULLY SUPERVISE children in same room as appliance.
- Alert children and adults to hazards of high temperatures.
- Do NOT operate with protective barriers open or removed.
- Keep clothing, furniture, draperies and other combustibles away.

CAUTION

Tested and approved for wood pellets and shelled field corn fuel only. Burning of any other type of fuel voids your warranty.

CAUTION

- Check building codes prior to installation.
- Installation MUST comply with local, regional, state and national codes and regulations.
 - Consult local building, fire officials or authorities having jurisdiction about restrictions, installation inspection, and permits.

Congratulations

and Welcome to the Quadra-Fire Family!

Hearth & Home Technologies welcomes you to our tradition of excellence! In choosing a Quadra-Fire appliance, you have our assurance of commitment to quality, durability, and performance.

This commitment begins with our research of the market, including 'Voice of the Customer' contacts, ensuring we make products that will satisfy your needs. Our Research and Development facility then employs the world's most advanced technology to achieve the optimum operation of our stoves, inserts and fireplaces. And yet we are old-fashioned when it comes to craftsmanship. Each unit is

meticulously fabricated and gold and nickel surfaces are hand-finished for lasting beauty and enjoyment. Our pledge to quality is completed as each model undergoes a quality control inspection. From design, to fabrication, to shipping: Our guarantee of quality is more than a word, it's Quadra-Fire tradition, and we proudly back this tradition with a Limited Lifetime Warranty.

We wish you and your family many years of enjoyment in the warmth and comfort of your hearth appliance. Thank you for choosing Quadra-Fire.

With warm regards,

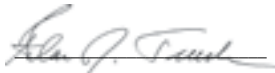

Alan Trusler
Vice President
Dealer Channel

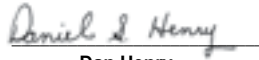

Dan Henry
Vice President
Advanced Technologies



Jason Olmstead
Vice President &
General Manager



Steve Tate
Quadra-Fire
Brand Manager

CLEARANCE TO COMBUSTIBLES LABEL LOCATED INSIDE HOPPER LID
SERIAL NUMBER & MANUFACTURE DATE LABEL LOCATED UNDER TOP ON INSIDE OF HOPPER BODY



CAUTION: HOT WHILE IN OPERATION DO NOT TOUCH. KEEP CHILDREN, CLOTHING AND FURNITURE AWAY. CONTACT MAY CAUSE SKIN BURNS. SEE NAMEPLATE AND INSTRUCTIONS. Operate this unit with fuel hopper lid closed. Failure to do so may result in emissions products' combustion from the hopper under certain conditions. Maintain hopper seal in good condition. Do not over fill the hopper.

ATTENTION: CHAUD LORS DE L'OPÉRATION. NE PAS TOUCHER. GARDEZ LES ENFANTS ET LES VÊTEMENTS LOIN DE L'ESPACE DESIGNÉ DE L'INSTALLATION. LE CONTACT PEUT CAUSER DES BRÛLURES À LA PEAU. VOIR L'ÉTIQUETTE ET LES INSTRUCTIONS. Opérez cet appareil avec le couvercle de la trémie fermé. Le défaut de ne pas suivre les instructions peut résulter, sous certaines conditions, en une combustion des émissions des produits venant de la trémie. Ne pas remplir la trémie trop pleine.

Safety and clearance section located on inside of hopper lid./Serial Number section located under top on inside of hopper body.
La section se réfère aux distances de sécurité est située à l'intérieur du couvercle de la trémie à la boîte à feu. La section du numéro de série est située en dessous du couvercle à l'intérieur de la trémie.

Test Lab & Report No.



QUADRA-FIRE

1200-I Pellet Insert



1445 Highway North, Colville, WA 99114
www.quadrafire.com

Listed Solid Fuel Room Heater/Pellet Type Insert. Also suitable for Mobile Home Installation. This appliance has been tested and listed for use in Manufactured Homes in accordance with OAR 814-23-9000 through 814-23-909.

Tested to: ASTM E 1509, UL127, ULC S610, ULC C1482-M1990 Room Heating Pellet Burning Type, APFI (UM) 84-HUD FOR USE ONLY WITH PELLETIZED WOOD OR SHELLED FIELD CORN FUEL.

Input Rating Maximum 5.5 lb fuel/hr.

Electrical Rating: 115 VAC, 60 Hz, Start 4.1 Amps, Run 1.1 AMPS.

Route power cord away from unit. Do not route cord under or in front of appliance.

DANGER: Risk of electrical shock. Disconnect power supply before servicing. Replace glass only with 5mm ceramic available from your dealer.

To start, set thermostat above room temperature, the stove will light automatically. To shutdown, set thermostat to below room temperature. For further instruction refer to owner's manual. Keep viewing and ash removal doors tightly closed during operation.

Model Name

Appareil de chauffage inséré de combustible solide type de bouillottes. Accepté dans l'installation dans les maisons mobiles. Cet appareil a été testé et enregistré pour l'usage dans les Maisons Mobiles en accord avec OAR 814-23-9000 jusqu'à 814-23-909.

Testé à: ASTM E 1509, UL127, ULC S610, ULC C1482-M1990 Room Heating Pellet Burning Type, APFI (UM) 84-HUD POUR USAGE AVEC LES BOULETTES DE BOIS OU DE COMBUSTIBLE DE MAIS ÉCOSSÉES DES CHAMPS.

Consommation maximale à l'entrée (sans pertes) 2,5 kg/h.

Puissance Électrique: 115 VAC, 60 Hz, Début 4,1 Amps, Courir 1,1 Amps.

Éloignez le fil électrique de l'appareil. Ne pas faire passer le fil électrique au dessus ou en dessous de l'appareil.

DANGER: Il y a un risque de choc électrique. Déconnectez le fil électrique de la prise de contact avant le service.

Remplacez votre verrement avec une vitre céramique de 5 mm disponible chez votre fournisseur.

Pour commencer, régler la température du thermostat au dessus de la température de la pièce, le poêle s'allumera automatiquement. Pour éteindre, descendre la température du thermostat en dessous de la température de la pièce. Pour des instructions supplémentaires, référez vous au manuel du propriétaire. Gardez la porte d'ouverture et la porte des cendres fermées hermétiquement durant l'opération.

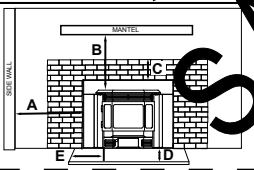

Manufacturer of *Zero Clearance Minimum Clearances to Combustible*
Fabricateur ou zéro distance foyer distances minimales à tout matériel combustible.

A	Openings to combustible wall	6" (152mm)	A	Lucarne au mur combustible	152mm
B	Insert top to mantel	12" (305mm)	B	Dessus de l'insert à la tablette de cheminée	305mm
C	Front Facing	3" (76mm)	C	Revêtement facial	76mm
D	Hearth Extension - Front	6" (152mm)	D	Protection de sol - frontal	152mm
E	Hearth Extension - Side	8" (203mm)	E	Protection de sol - côté	203mm

*See hearth protection note above. *Voir les notes sur la protection de sol ci-dessus.

U.S. ENVIRONMENTAL PROTECTION AGENCY OMNI Test Laboratories, Inc., Beaverton, Or Report/Rapport 061-S-12-2
This model is exempt from EPA certification under 40 CFR 60.531 by definition [Wood Heater (A) "Air-to-Fuel Ratio"].

QUADRA-FIRE

1200-I PELLET INSERT

SERIAL NO. / NUMÉRO DU

007C

Manufactured Date

DO NOT REMOVE THIS LABEL / NE PAS ENLEVER L'ÉTIQUETTE

DO NOT REMOVE THIS LABEL / NE PAS ENLEVER L'ÉTIQUETTE

250-4594

2006 2007 2008 JAN FEB MAR APR MAY JUNE JULY AUG SEPT OCT NOV DEC

DO NOT REMOVE THIS LABEL / NE PAS ENLEVER L'ÉTIQUETTE

Made in China/Fait Aux Chine

250-4594

TABLE OF CONTENTS

Section 1: Listing and Code Approvals

- A. Appliance Certifications4
- B. Mobile Home Approved4
- C. Glass Specifications.....4
- D. Electrical Rating4
- E. BTU & Efficiency Specifications4

Section 2: Getting Started

- A. Design, Installation & Location Considerations.....5
- B. Fire Safety5
- C. Tools & Supplies Needed6
- D. Measuring Standards.....6
- E. Inspect Appliance, Components and Pre-Check List6

Section 3: Dimensions & Clearances

- A. Appliance Dimensions7
- B. Clearances to Combustibles As A Built-In, UL and ULC8
- C. Clearances to Combustibles, Masonry & Zero Clearance.....9
- D. Minimum Opening for Factory Built Fireplace9
- E. Masonry Minimum Opening.....10
- F. Floor Protection10
- G. Calculating Alternate Floor Protection Material.....10
- H. Removing Floor of Factory Built Fireplace11

Section 4: Vent Information

- A. Chimney & Exhaust Connections12
- B. Venting Termination Requirements12
- C. Equivalent Feet of Pipe.....13
- D. Pipe Selection Chart.....13

Section 5: Venting Systems

- A. Direct Connect with Outside Air14
- B. Direct Connect without Outside Air14
- C. Full Reline with Outside Air.....15

Section 6: Mobile Home16

Section 7: Appliance Set-Up

- A. Rear Shroud Installation17-18
- B. Outside Air Kit.....19
- C. Adjustable Hopper Option.....19
- D. Grille Installation19
- E. Adjustable Hearth Support.....20
- F. Panel & Trim21-22
- G. Log Set Placement.....23
- H. Thermostat Installation.....23

Section 8: Operating Instructions

- A. Fuel Size & Material24
- B. General Operation Information24
- C. Before Your First Fire25
- D. Fuel Adjustment Control Rod.....25
- E. Starting Your First Fire.....25
- F. Fire Characteristics.....25
- G. Feed Rate Adjustment25
- H. Ignition Cycles25
- I. Frequently Asked Questions.....26

Section 9: Troubleshooting27-29

Section 10: Maintaining & Servicing Appliance

- A. Proper Shutdown Procedure.....30
- B. General Maintenance & Cleaning30-32
- C. High Ash Content Maintenance32-33
- D. Igniter Replacement.....33
- E. Glass Replacement.....34
- F. Baffle Removal.....34

Section 12: Reference Material

- A. Component Functions.....35-36
- B. Component Locations.....37
- C. Exploded Drawings.....37-38
- D. Service Parts & Accessories.....39-41
- E. Service & Maintenance Log.....42
- F. Warranty Policy.....43
- G. Contact Information44

1

Listing and Code Approvals

A. Appliance Certification

MODEL:	1200-I Pellet Insert
LABORATORY:	OMNI Test Laboratories, Inc
REPORT NO.	061-S-13-2
TYPE:	Solid Fuel Room Heater/Pellet Type Insert
STANDARD:	ASTM E1509, ULC S628 and ULC/ORD-C1482 Room Heater Pellet Fuel Burning Type and (UM) 84-HUD, Mobile Home Approved

B. Mobile Home Approved

This appliance is approved for mobile home installations when not installed in a sleeping room and when an outside combustion air inlet is provided. The structural integrity of the mobile home floor, ceiling, and walls must be maintained. The appliance must be properly grounded to the frame of the mobile home and use only listed pellet vent, Class "L" or "PL" connector pipe. A Quadra-Fire Outside Air Kit must be installed in a mobile home installation.

C. Glass Specifications

This appliance is equipped with 5mm ceramic glass. Replace glass only with 5mm ceramic glass. Please contact your dealer for replacement glass.

NOTE: This installation must conform with local codes. In the absence of local codes you must comply with the **ASTM E1509, (UM) 84-HUD, ULC/ORD-C-1482**

D. Electrical Rating

115 VAC, 60 Hz, Start 4.1 Amps, Run 1.1 Amps

E. BTU & Efficiency Specifications

Emissions Rating:	.9 grams/hr
*BTU Output:	14,000 - 40,000 / hr
Heating Capacity:	up to 2,500 sq. ft.
Hopper Capacity:	60-75 lbs
Fuel:	Wood Pellets or Shelled Corn
Shipping Weight:	243 lbs

*BTU output will vary, depending on the brand of fuel you use in your appliance. Consult your Quadra-Fire dealer for best results.

NOTE: Hearth & Home Technologies, manufacturer of this appliance, reserves the right to alter its products, their specifications and/or price without notice.

2

Getting Started

A. Design, Installation & Location Considerations

1. Appliance Location

Consideration must be given to safety, convenience, traffic flow, and the fact that the appliance will need a chimney and chimney connector. It is a good idea to plan your installation on paper, using exact measurements for clearances and floor protection, before actually beginning the installation. If you are not using an existing chimney, place the appliance where there will be a clear passage for a factory-built listed chimney through the outside wall or ceiling and roof.

Check with your local building code agency before you begin your installation. Be sure local building codes do not supersede UL specifications and always obtain a building permit so that insurance protection benefits cannot be unexpectedly cancelled. If any assistance is required during installation, please contact your local dealer.

We recommend that a qualified building inspector and your insurance company representative review your plans before and after installation.

2. Thermostat Location

The thermostat's location will have some effect on the appliance's operation. When the thermostat is located close to the appliance, it may require a slightly higher temperature setting to keep the rest of the house comfortable. If the thermostat location is in an adjacent room or on a different floor level, you will notice higher temperatures near the appliance.

B. Fire Safety

Maintain the designated clearances to combustibles. Insulation must not touch the chimney. You must maintain the designated air space clearance around the chimney. This space around a chimney is necessary to allow natural heat removal from the area. Insulation in this space will cause a heat buildup, which may ignite wood framing. **NOTE: Clearances may only be reduced by means approved by the regulatory authority having jurisdiction.**



To provide reasonable fire safety, the following should be given serious consideration:

1. Install at least one smoke detector on each floor of your home to ensure your safety. They should be located away from the heating appliance and close to the sleeping areas. Follow the smoke detector manufacturer's placement and installation instructions, and be sure to maintain regularly.
2. A conveniently located Class A fire extinguisher to contend with small fires resulting from burning embers.
3. A practiced evacuation plan, consisting of at least 2 escape routes.
4. A plan to deal with a hopper fire as follows:

In the event of a hopper fire:

- a. Notify fire department.
- b. Prepare occupants for immediate evacuation.
- c. Close all openings into the appliance.
- d. Unplug appliance.
- e. While awaiting fire department, watch for ignition of adjacent combustibles from overheated vent pipe, hot embers or sparks from the chimney.
- f. Pour a bucket of water into the appliance hopper.

	CAUTION
<ul style="list-style-type: none"> • Do NOT connect this unit to a chimney flue servicing another appliance. • Do NOT connect to any air distribution duct or system. 	

	WARNING
	<p>Fire Risk.</p> <ul style="list-style-type: none"> • Do not operate appliance before reading and understanding operating instructions. • Failure to operate appliance properly may cause a house fire.
	

C. Tools And Supplies Needed

Tools and building supplies normally required for installation, unless installing into an existing masonry fireplace:

- | | |
|---------------------------|------------------------------|
| Reciprocating Saw | Safety Glasses |
| Hammer | Framing Square |
| Phillips Screw driver | Electric Drill & Bits (1/4") |
| Tape Measure | 1/4" Self-Tapping Screws |
| Plumb Line | |
| Level | <u>May also need:</u> |
| Framing Material | Vent Support Straps |
| Hi-temp Caulking Material | Venting Paint |
| Gloves | |

D. Measuring Standards

1. Pipe measurements are from center line to center line.
2. Vertical terminations are measured to top of pipe.

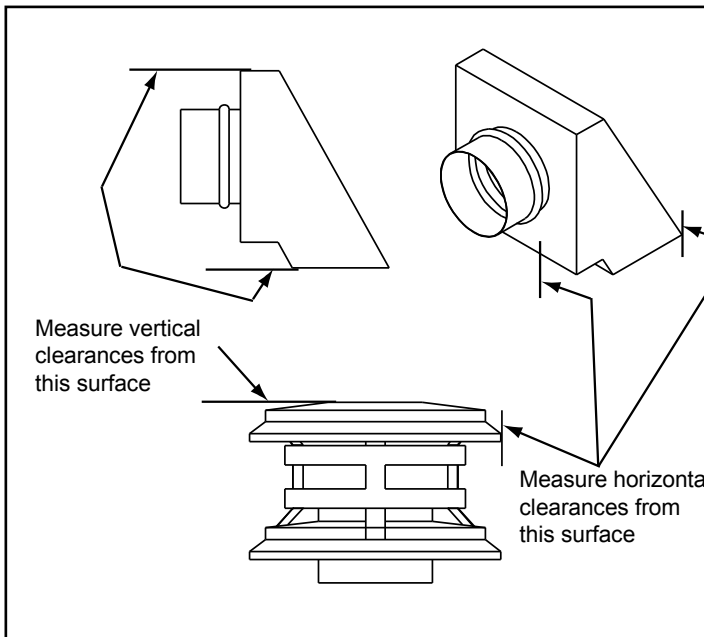





Figure 6.1

	 WARNING
<p>Inspect appliance and components for damage. Damaged parts may impair safe operation.</p> <ul style="list-style-type: none"> • Do NOT install damaged components. • Do NOT install incomplete components. • Do NOT install substitute components. <p>Report damaged parts to dealer.</p>	

E. Inspect Appliance & Components and Pre-Use Check List

1.		Place the appliance in a location near the final installation area and follow the procedures below:
2.		Open the appliance and remove all the parts and articles packed inside the Component Pack. Inspect all the parts and glass for shipping damage. Contact your dealer if any irregularities are noticed.
3.		All safety warnings have been read and followed.
4.		This Owner's Manual has been read.
5.		Floor protection requirements have been met.
6.		Venting is properly installed.
7.		The proper clearances from the appliance and chimney to combustible materials have been met.
8.		The masonry chimney is inspected by a professional and is clean, or the factory built metal chimney is installed according to the manufacturer's instructions and clearances.
9.		The chimney meets the required minimum height.
10.		All labels have been removed from the glass door.
11.		Plated surfaces have been wiped clean, if applicable.
12.		Thermostat or remote has been installed.
13.		A power outlet is available nearby.

	 WARNING
<p>Fire Risk. Hearth & Home Technologies disclaims any responsibility for, and the warranty will be voided by, the following actions:</p> <ul style="list-style-type: none"> • Installation and use of any damaged appliance. • Modification of the appliance. • Installation other than as instructed by Hearth & Home Technologies. • Installation and/or use of any component part not approved by Hearth & Home Technologies. • Operating appliance without fully assembling all components. • Do NOT Overfire. <p>Or any such action that may cause a fire hazard.</p>	

3 Dimensions and Clearances

A. Appliance Dimensions

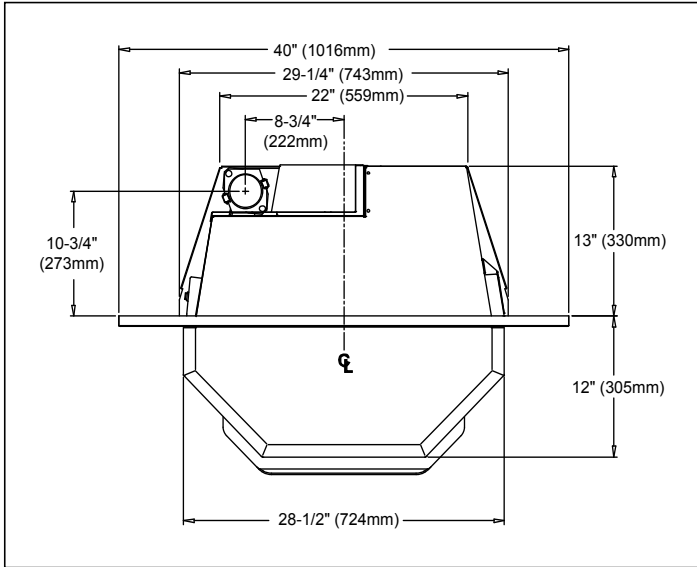

Figure 7.1 - Top View

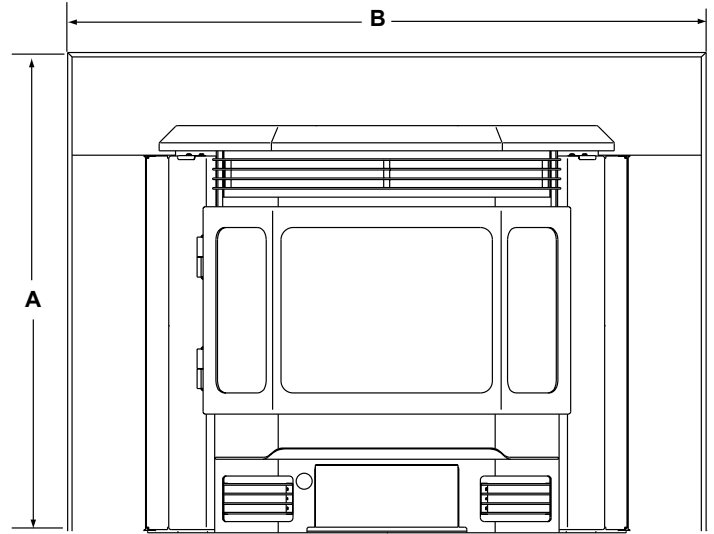

Figure 7.2 - Front View

Panel	A	B
Standard	30 inches (762mm)	40 inches (1016mm)
Large	33 inches (838mm)	50 inches (1270mm)

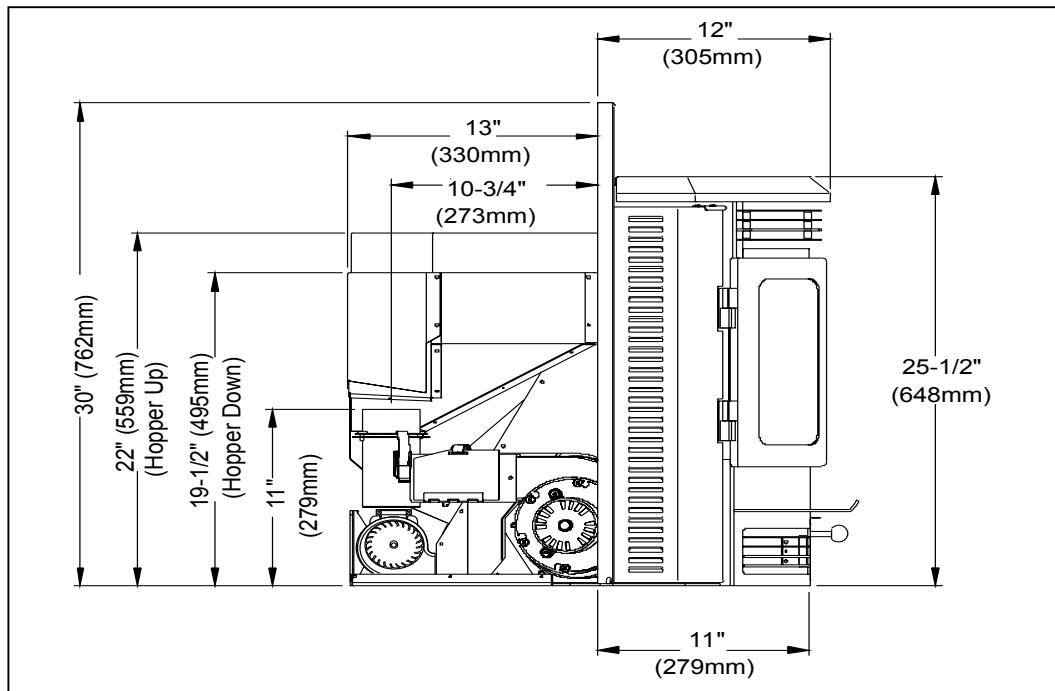

Figure 7.3 - Side View

B. Clearance To Combustibles, UL and ULC

AS A BUILT-IN

**Rear Shroud Kit, Part 811-0680 is Required for Built-In Installation
(see pages 17-18 for installation instructions)**

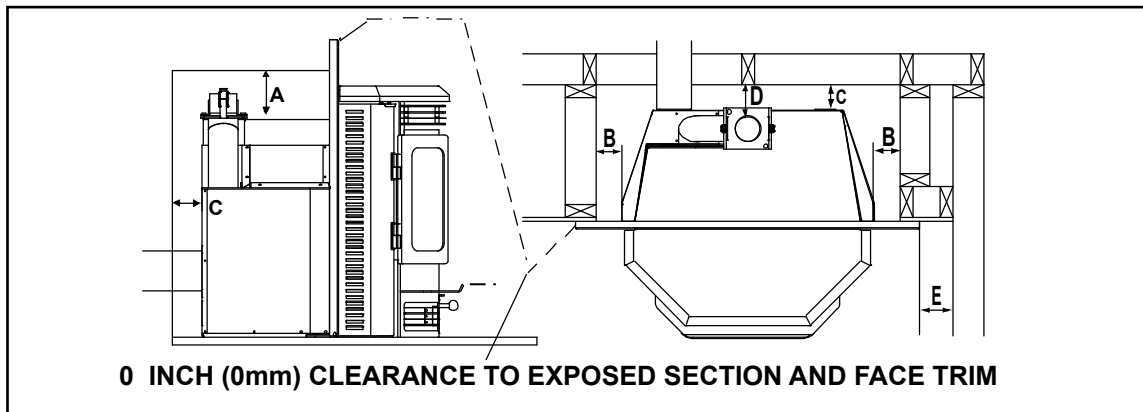

Figure 8.1

		Inches	Millimeters	
A	Top of Shroud	Top Vent	3.0	76
		Rear Vent	0	0
B	Sides of Inside Shroud	Top or Rear Vent	0	0
C	Back of Inside Shroud	Top Vent	2.5	64
		Rear Vent	0	0
D	Vent Pipe to Combustible	Top or Rear Vent	3.0	76
E	From Outside Edge of Panel Set to Combustibles		0	0

**INSTALLED AS A BUILT-IN UNIT
Shown with Rear Vent and Optional Outside Air**

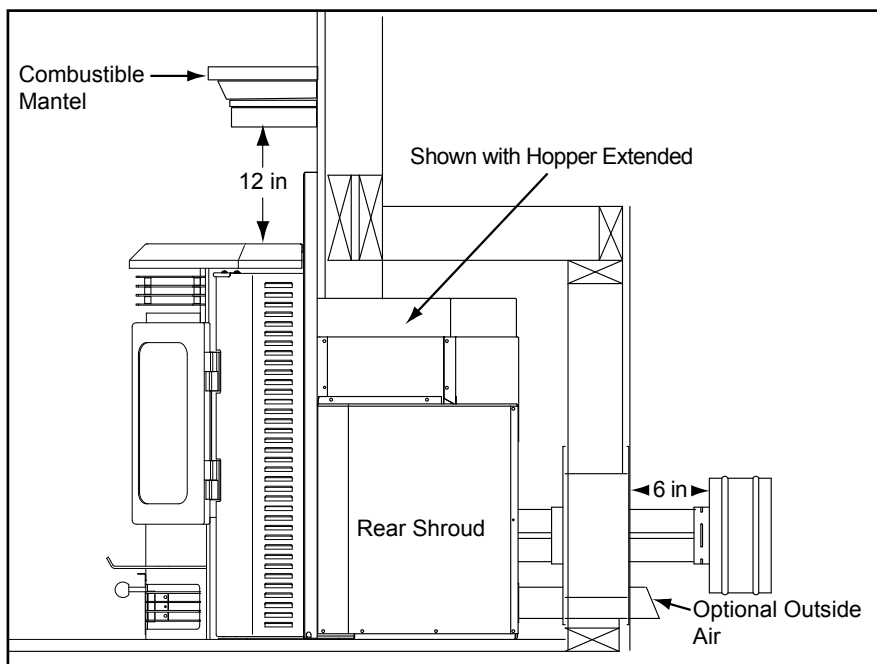



Figure 8.2



WARNING

Fire Risk.
Comply with all minimum clearances to combustibles as specified.

Failure to comply may cause house fire.

NOTE:

- Illustrations reflect typical installations and are FOR DESIGN PURPOSES ONLY.
- Illustrations/diagrams are not drawn to scale.
- Actual installation may vary due to individual design preference.

C. Minimum Clearances To Combustibles for Masonry and Zero Clearance Fireplaces

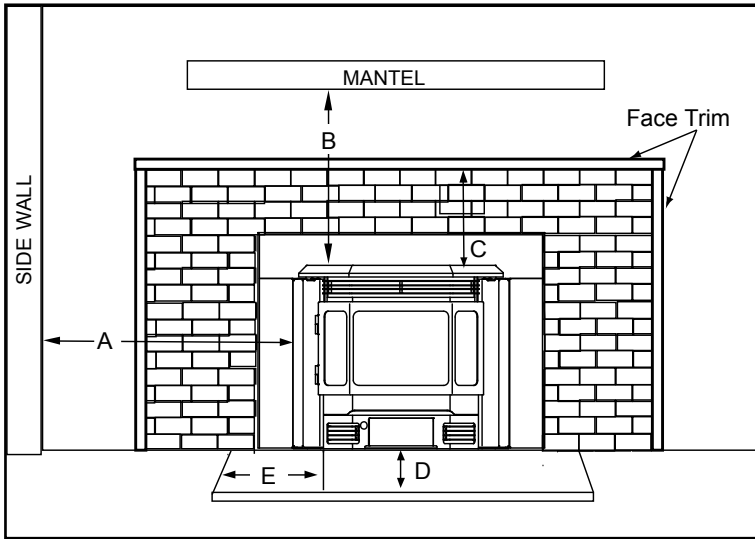

		Inches	Millimeters
A	Louvers to combustible side wall	6	153
B	Insert top to mantel	12	305
C	Front Facing	3	76
D	Hearth Extension - Front	6	153
E	Hearth Extension - Sides	8	203

Figure 9.1

D. Minimum Opening for Masonry and Zero Clearance Fireplaces for Built-In Using Rear Shroud

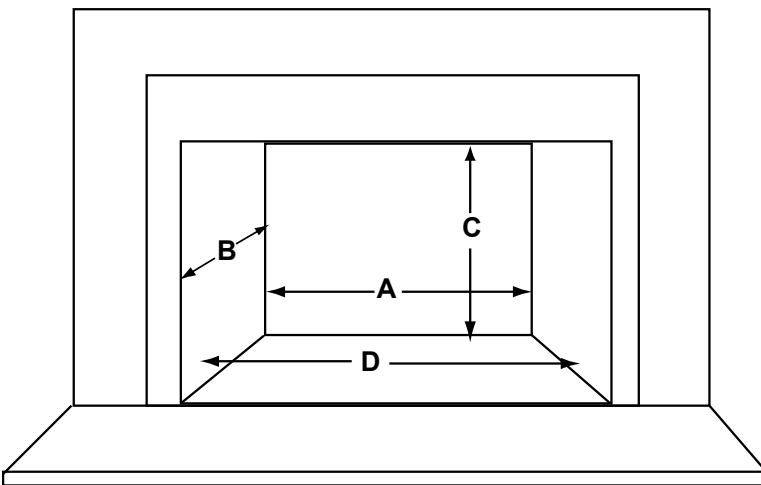

Figure 9.2

NOTE: A Quadra-Fire floor protector (Part 811-0730) is available through your dealer to be used as a floor protector for the section under the insert body only. Floor protection to front and sides of insert unit must be supplied in addition to this part.

		Inches	Millimeters
A	Rear Width	22	558
B	Depth	15-1/2	393
C*	Height - Top Vent	25-1/2	647
	Height - Rear Vent	22-1/2	571
D	Front Width	29-1/4	743

*The size of your floor protector choice must be added to this dimension. If using Quadra-Fire floor protector, Part 811-0730, allow 1-1/2" (38mm).

E. Masonry Minimum Opening

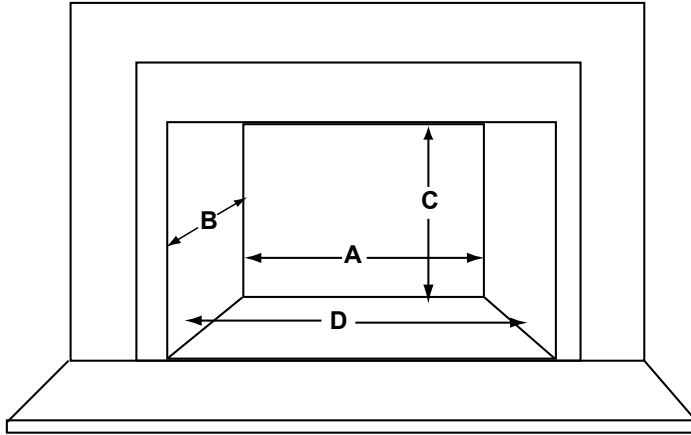

	Location	Inches	Millimeters
A	Rear Width	22	558
B	Depth	13	330
C	Height - Top Vent	19-1/2	495
D	Front Width	29-1/4	743

F. Floor Protection

1. Zero Clearance Installations*

It is necessary to install a floor protection of non-combustible material with a R value of 3.0 (1 inch [25mm] minimum thickness with a “k” value of 0.58) or a 1 inch (25mm) air space between insert base and hearth.

2. Non-Zero Clearance Installations*

A non-combustible floor protector is required with a minimum R value of 3.0 (1 inch [25mm] minimum thickness with a “k” value of 0.58) extending 6 inches (153mm) in front of the insert and 8 inches (203mm) to each side of the door opening.

* See alternate floor protection worksheet.

G. Calculating Alternate Floor Protection Material

Thermal Conductivity: k value

The k value indicates the amount of heat (in BTU's) that will flow in 1 hour through 1 square foot of a uniform material 1 inch thick for each degree (F) of temperature difference from one side of the material to the other. The LOWER the k factor means less heat is being conducted through the non-combustible material to the combustible material beneath it. The k value of a material must be equal or smaller then the required k value to be acceptable.

$$\frac{\text{(BTU) (inch)}}{\text{(foot}^2 \text{ (hour) (}^\circ\text{F)}}$$

Thermal Resistance: R value

The R value is a measure of a material's resistance to heat transfer. R value is convenient when more than one material is used since you can add the R values together, whereas you can not do this for k value. The HIGHER the R factor means less heat is being conducted through the non-combustible material to the combustible material beneath it. The R value of a material must be equal or larger then the required R value to be acceptable.

Converting k to R:

Divide 1 by k and multiply the results times the thickness in inches of the material.

$$R = 1/k \times \text{inches of thickness}$$

Converting R to k:

Divide the inches of thickness by R.

$$k = \text{inches of thickness}/R$$

Calculations:

Example: Floor protection requires k value of 0.84 and 3/4 inch thick.

Alternative material has a k value of 0.6 and is 3/4 inch thick.

Divide 0.6 by .75 = k value of 0.80. This k value is smaller than 0.84 and therefore is acceptable.

H. Removing Metal Floor of Factory-Built Firebox

- The firebrick (refractory), glass doors, screen rails, screen mesh and log grates can be removed from a factory-built firebox in order to gain minimum insert opening requirements.
- Any smoke shelves, shields and baffles may be removed from a factory-built firebox if attached with mechanical fasteners.
- The metal floor of the factory-built firebox may be removed to facilitate the installation of the insert only when a 1 inch (25mm) airspace is provided between the insert and the floor of outer wrap.
- If the floor is made of thin metal, we recommend using a Quarda-Fire floor protector, Part 811-0730, which is available through your dealer.

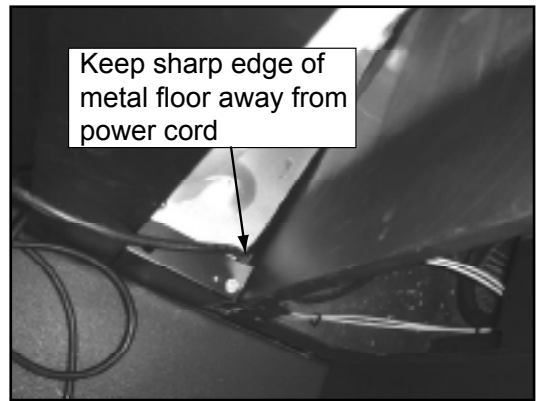

Figure 11.3. Place the insert into the factory-built firebox. Ensure that the power cord can not be damaged by the sharp metal edge. You may need to cut out a notch to accommodate the cord.

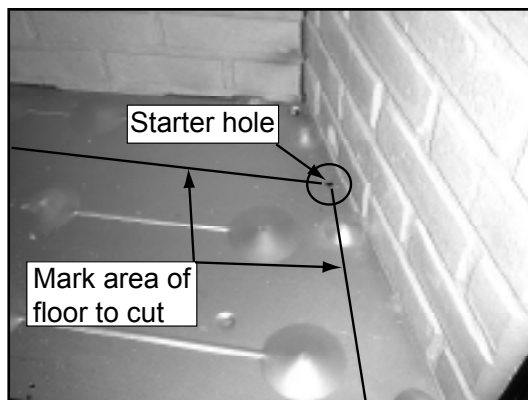

Figure 11.1. Measure and mark the metal floor for cutting. With a drill, make a starter hole in each corner.



Figure 11.2. Using a saws-all, cut out the floor.

4 Vent Information

A. Chimney and Exhaust Connection

1. **Chimney & Connector:** Use 3 or 4 inch (76-102mm) diameter type "L" or "PL" venting system. It can be vented vertically or horizontally.
2. **Mobile Home:** Approved for all listed pellet vent. Use listed double wall flue connector. A Quadra-Fire Outside Air Kit must be used with manufactured home installations.
3. **Residential:** Use 24 gauge single wall flue connector or listed double wall flue connector to Class A listed metal chimneys, or masonry chimneys meeting national and/or local codes for solid fuel appliances.
4. **INSTALL VENT AT CLEARANCES SPECIFIED BY THE VENT MANUFACTURER.**
5. Secure exhaust venting system to the appliance with at least 3 screws. Also secure all connector pipe joints with at least 3 screws through each joint.

NOTE: All pipe must be welded seam pipe whenever possible. Seal pipe joints with high temperature silicone (500°F [260°C] minimum rated only).

NOTE: If burning shelled field corn, you must use approved venting specifically designed for corn. Follow the instructions from the venting manufacturer.

B. Venting Termination Requirements

CAUTION

Do not terminate vent in any enclosed or semi-enclosed area such as a carport, garage, attic, crawl space, under a sun deck or porch, narrow walkway or closely fenced area, or any location that can build up a concentration of fumes such as a stairwell, covered breezeway, etc.

1. Termination must exhaust above air inlet elevation. It is recommended that at least 60 inches (1524mm) of vertical pipe be installed when appliance is vented directly through a wall. This will create a natural draft, which will help prevent the possibility of smoke or odor venting into the home during a power outage. It will also keep exhaust from causing a nuisance or hazard by exposing people or shrubs to high temperatures. The safest and preferred venting method is to extend the vent vertically through the roof.
2. Distance from doors and opening windows, or gravity or ventilation air inlets into building:
 - a. Not less than 48 inches (1219mm) below;
 - b. Not less than 48 inches (1219mm) horizontally from;
 - c. Not less than 12 inches (305mm) above.
3. Distance from permanently closed windows:
 - a. Not less than 12 inches (305mm) below, horizontally from or above.
4. Distance between bottom of termination and grade should be 12 inches (305mm) minimum. This is conditional upon plants in the area, and nature of grade surface. The grade surface must be a non-combustible material (i.e., rock, dirt). The grade surface must not be lawn. Distance between bottom of termination and public walkway should be 84 inches (2134mm) minimum.
5. Distance to combustible materials must be 24 inches (610mm) minimum. This includes adjacent buildings, fences, protruding parts of the structure, roof overhang, plants and shrubs, etc.
6. Termination Cap Location (Home Electrical Service)
 - Side-to-side clearance is to be the same as minimum clearance to vinyl inside corners.
 - Clearance of a termination cap below electrical service shall be the same as minimum clearance to vinyl soffits.
 - Clearance of a termination cap above electrical service will be 12 inches (305mm) minimum.
 - Location of the vent termination must not obstruct or interfere with access to the electrical service.

	WARNING
	<p>Fire Risk.</p> <ul style="list-style-type: none"> • Only LISTED venting components may be used. • NO OTHER vent components may be used. Substitute or damaged vent components may impair safe operation.

	WARNING
	<p>Vent surfaces get HOT, can cause burns if touched. Non-combustible shielding or guards may be required</p>

C. Equivalent Feet of Pipe

The table below can help you calculate the equivalent feet of pipe which is a method used to determine pellet vent size. **See Figure 13.1**

WARNING

Improper installation, adjustment, alteration, service or maintenance can cause injury or property damage. Refer to the owner's information manual provided with this appliance. For assistance or additional information consult a qualified installer, service agency or your dealer.

Example of 3 Elbow-Rear Vent Termination Calculation

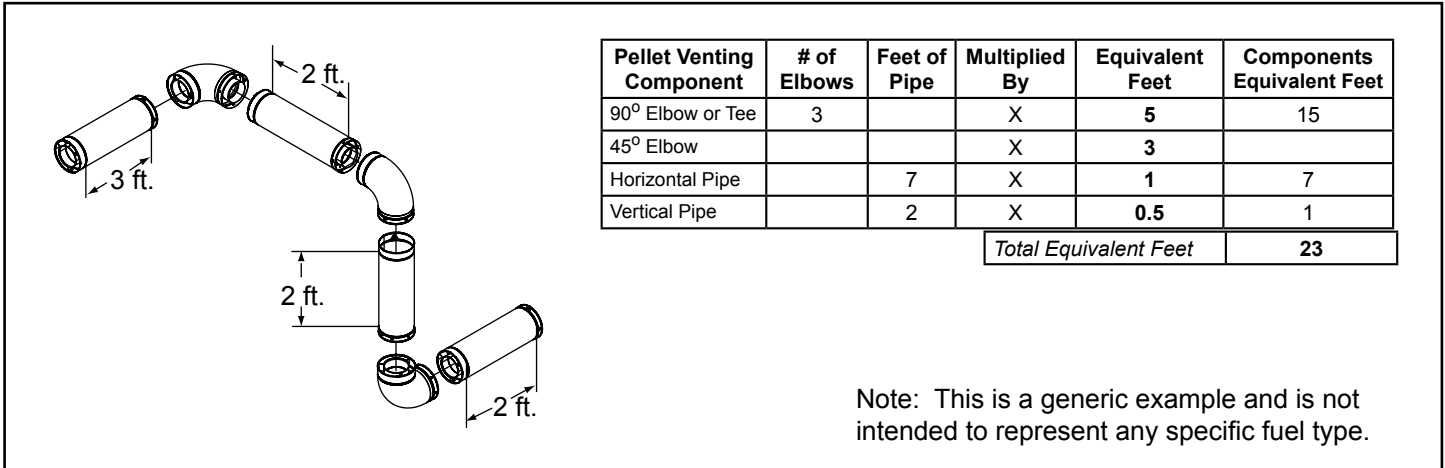

Note: This is a generic example and is not intended to represent any specific fuel type.

Figure 13.1

D. Pipe Selection Chart

The chart will help you in determining proper venting size according to the equivalent feet of pipe calculated above and the altitude above sea level of this installation. **See Figure 13.2.**

Locate the calculated equivalent feet of pipe on the vertical left side of the chart. Move to the right horizontally on the chart until you reach your altitude above sea level.

If you fall below the diagonal line, 3 or 4 inch (76 to 102mm) pipe may be used. If it is anywhere above the diagonal line, a 4 inch (102mm) diameter pipe is required.

The chart reveals that a 90° elbow is 5 times as restrictive to the flow of exhaust gases under positive pressure as 1 foot of horizontal pipe, and a foot of horizontal pipe is twice as restrictive as a foot of vertical pipe.

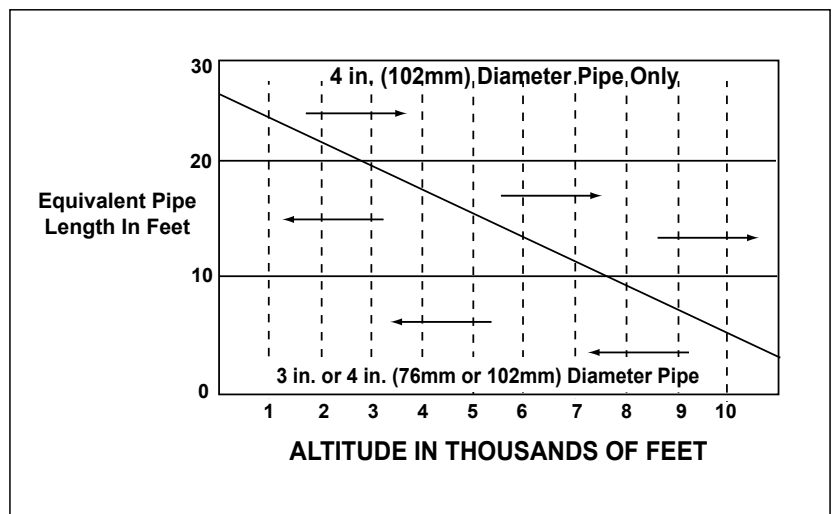

Figure 13.2

5 Venting Systems

A. Direct Connect With Outside Air

B. Direct Connect Without Outside Air

NOTE: In Canada, only a full reline is allowed per ULC S-628, ORD ULC C1482.

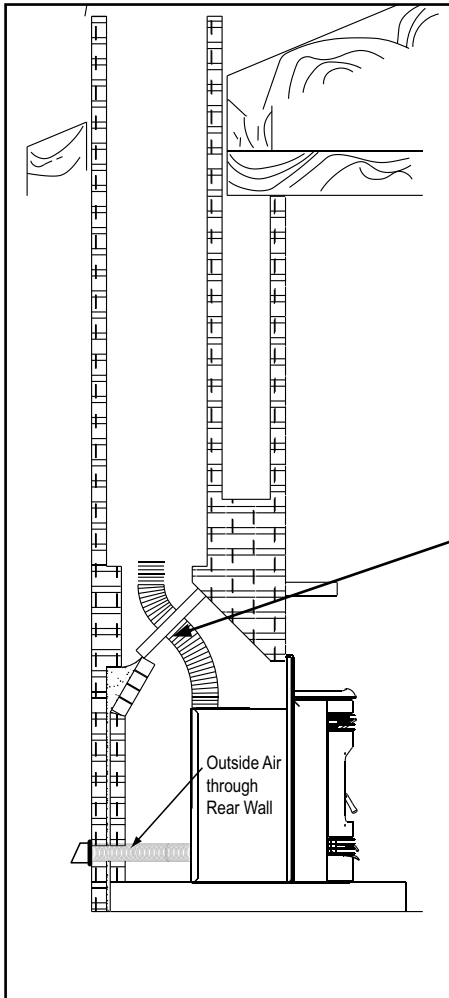

Figure 14.1

NOTE; Use metal plate around exhaust vent pipe and seal all edges with non-flammable insulation such as fiberglass, mineral wool or ceramic material.

Do not use high temperature caulking materials to seal any edge to prevent future serviceability.

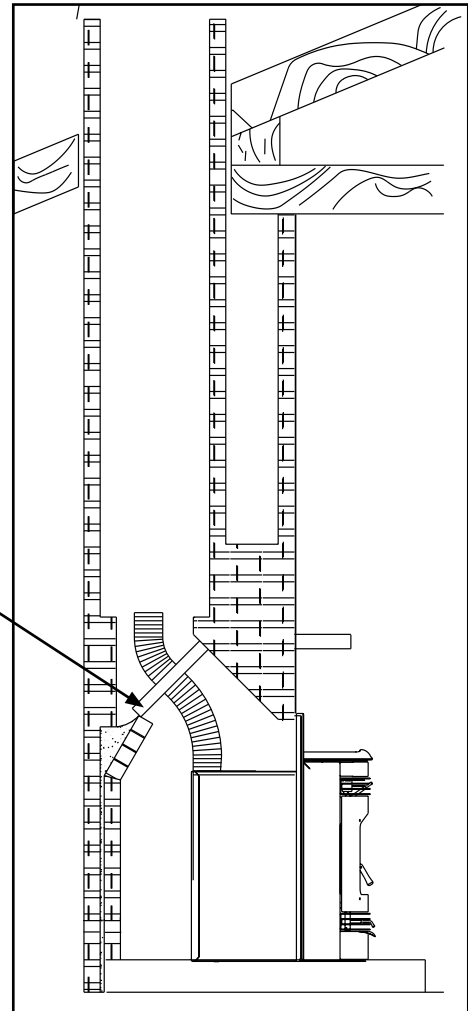

Figure 14.2

NOTE:

- Illustrations reflect typical installations and are FOR DESIGN PURPOSES ONLY.
- Illustrations/diagrams are not drawn to scale.
- Actual installation may vary due to individual design preference.

CAUTION

- Never draw outside combustion air from:
- Wall, floor or ceiling cavity
 - Enclosed space such as an attic or garage



WARNING



- Fire Risk.
Inspection of Chimney:
- Masonry chimney must be in good condition.
 - Meets minimum standard of NFPA 211
 - Factory-built chimney must be 6 inch (152mm) UL103 HT.

NOTE:

In Canada, where passage through a wall or partition of combustible construction is desired, the installation shall conform to CAN/CSA-B365.

C. Full Reline With Outside Air

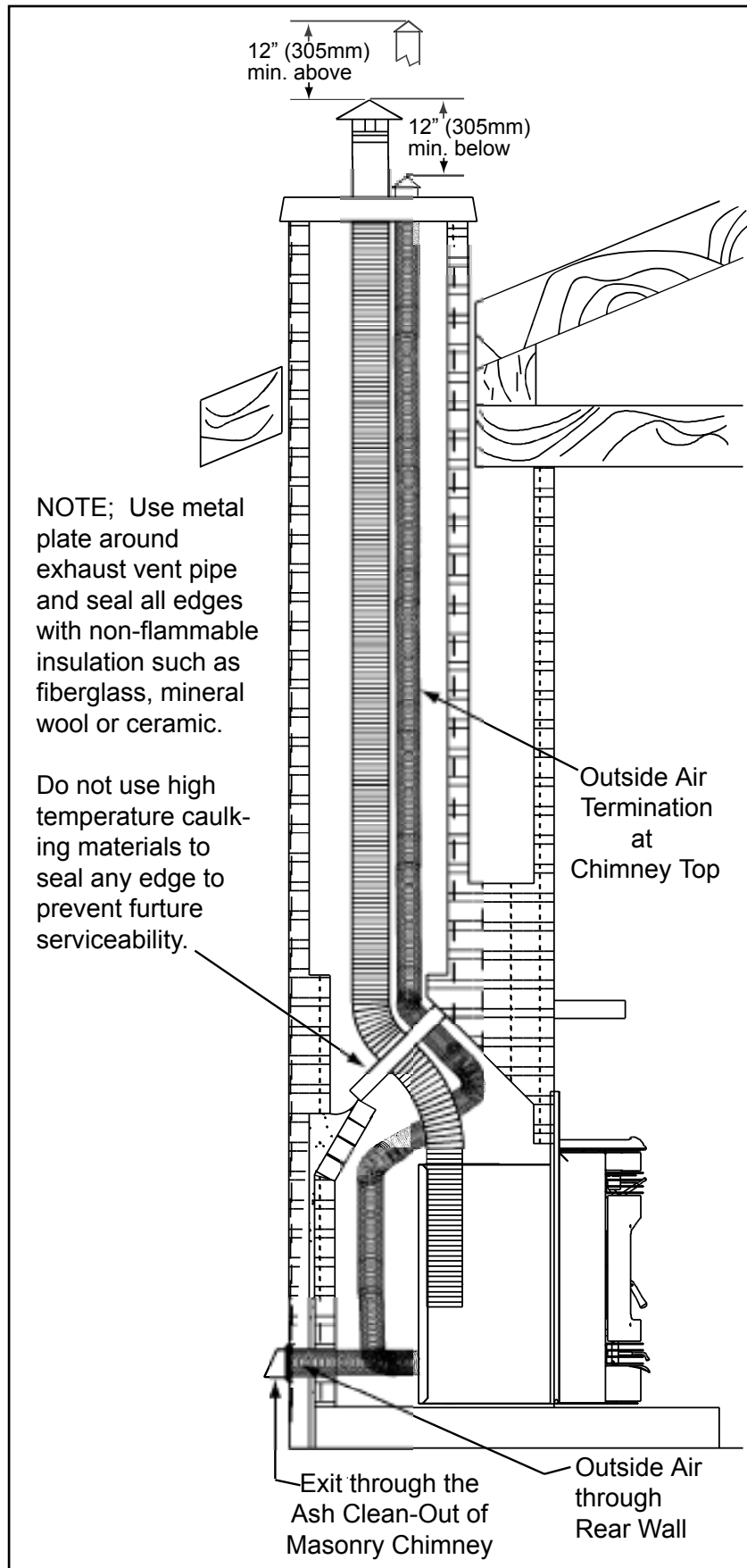

NOTE; Use metal plate around exhaust vent pipe and seal all edges with non-flammable insulation such as fiberglass, mineral wool or ceramic.

Do not use high temperature caulking materials to seal any edge to prevent future serviceability.

NOTE: Check clearances carefully for this type of installation to ensure adequate room for outside air venting.

NOTE: In Canada, only a full reline is allowed per ULC S-628, ORD ULC C1482.

CAUTION

- Check building codes prior to installation.
- Installation **MUST** comply with local, regional, state and national codes and regulations.
 - Consult local building, fire officials or authorities having jurisdiction about restrictions, installation inspection, and permits.

Figure 15.1

6 Mobile Home

A. Mobile Home Installation

You must use a Quadra-Fire Outside Air Kit for installation in a mobile home.

1. An outside air inlet must be provided for the combustion air and must remain clear of leaves, debris, ice and/or snow. It must be unrestricted while the appliance is in use to prevent room air starvation which causes smoke spillage. Smoke spillage can also set off smoke alarms.
2. The combustion air duct system must be made of metal. It must permit zero clearance to combustible construction and prevent material from dropping into the inlet or into the area beneath the dwelling and contain a rodent screen.
3. The appliance must be secured to the mobile home structure by bolting it to the floor (using lag bolts). Use the same holes that secured the appliance to the shipping pallet.
4. The appliance must be grounded with #8 solid copper grounding wire or equivalent, terminated at each end with an NEC approved grounding device.
5. Refer to Clearances to Combustibles and floor protection requirements on **pages 8 & 9** for listings to combustibles and appropriate chimney systems.
6. Use silicone to create an effective vapor barrier at the location where the chimney or other component penetrates to the exterior of the structure.
7. Follow the chimney manufacturer's instructions when installing the vent system for use in a mobile home.
8. Installation shall be in accordance with the Manufacturers Home & Safety Standard (HUD) CFR 3280, Part 24.

CAUTION
Maintain structural integrity of mobile home: <ul style="list-style-type: none"> • Floor, wall, ceiling and/or roof. Do NOT cut through: <ul style="list-style-type: none"> • Floor joist, wall studs or ceiling trusses. • Any supporting material that would affect the structural integrity.

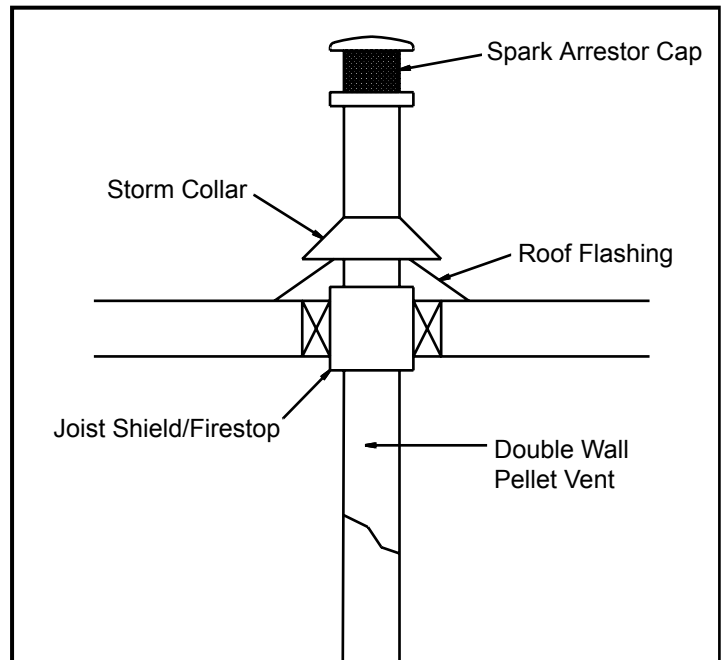



Figure 16.1

 WARNING
Installation must comply with Manufactured Home and Safety Standard (HUD), CFR 3280, Part 24.

 WARNING
Never install in a sleeping room.

7 Appliance Set-Up

A. Rear Shroud Installation

1. Top Vent Installations

Parts Required:

Part 811-0680, Rear Shroud Kit.

Includes: Six galvanized steel shroud pieces, two cover plates and fastener package.

Part 811-0650, Rear Shroud Top Vent

Includes: Vent pipe and two 1/4 - 20 x 3/4" bolts with nuts.

Part 811-0660, 3" Top Vent Adapter or Part 811-0670, 4" Top Vent Adapter

2. Rear vent installations

Parts Required:

Part 811-0680, Rear Shroud Kit.

Part 811-0690, Rear Vent Kit

Includes: Rear Vent Adapter and fastener package.

Tools Required:

Electric drill, 1/8" drill bit, Phillips screw driver, 3/8" wrench & 7/16" wrench, (7/16" socket wrench & high temperature silicone adhesive are also required for rear vent installations).

Complete the following procedures, based on your venting installation, prior to installing the rear shroud kit. (Note: All photos depict top vent installation).

Top Vent Installation Preparation

1. Remove the top vent adapter from the vertical exhaust transition pipe. **Figures 17.2 and 17.5.**
2. Use 2 screws to attach left corner filler piece of rear shroud to the insert hopper. **Figures 17.1 and 17.2.**
3. Use (2) 1/4 - 20 x 3/4" bolts with nuts to install rear shroud top vent to the exhaust transition. See boxed area in **Figure 17.3.** (Circled area, top vent adapter, will be installed later).
4. Install the left shroud panel corner at 3 points, 2 screws into back of hopper and 1 down into the filler piece). **Figure 17.4**

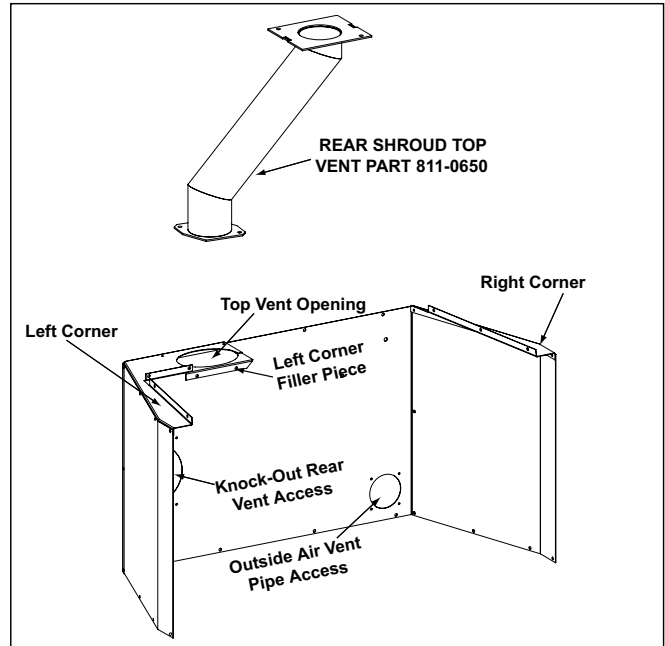

Figure 17.1

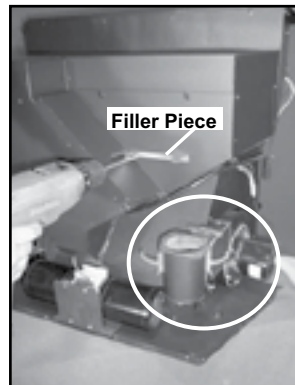

Figure 17.2

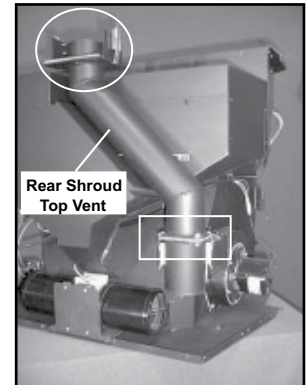

Figure 17.3

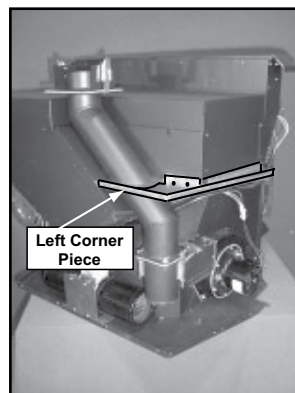

Figure 17.4

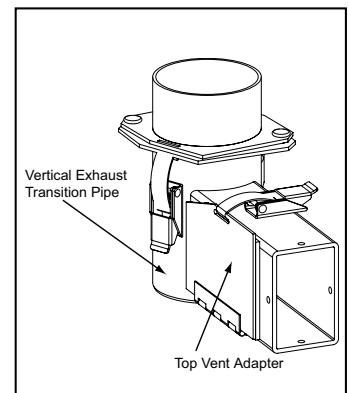

Figure 17.5

Rear Vent Installation Preparation:

1. Remove the ENTIRE exhaust blower housing by removing the 4 nuts using a 7/16" socket wrench. Set the nuts aside for later use.
2. Remove the 4 screws and remove the vertical exhaust transition pipe exhaust blower housing.
3. Remove any silicone sealant remaining on the blower housing.
4. Attach the rear vent adapter to the exhaust blower housing with 4 screws. **Figure 18.2.**
5. Apply a bead of high temperature silicone adhesive around the juncture of the blower housing and rear vent adapter, smoothing it around the joint to ensure that a good seal is made.
6. Re-install the exhaust blower housing (now with rear vent adapter attached) with the 4 nuts previously removed in Step 1.
7. Use 2 screws to attach left corner filler piece of rear shroud to the insert hopper. **Figures 17.1 & 17.2** on page 17.
8. Install the left shroud corner with 2 screws into the hopper body and 1 down into filler piece. **Figure 18.1.**
9. Install cover plate over top vent opening using 4 screws.

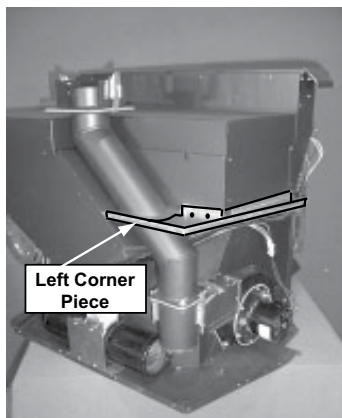

Figure 18.1

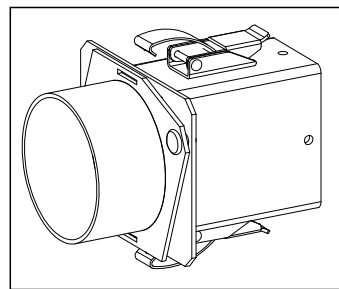

Figure 18.2

Installing Rear Shroud

Top Vent Applications: Leave knock-out plate in place. **Figure 18.3**

Rear Vent Applications: Clip corners of knock-out plate, remove and discard, prior to assembling rear shroud kit.

1. Install rear panel using 4 screws along bottom and 2 screws into the left shroud corner piece at the top. **Figure 18.3.**
2. If your installation does not include an outside air kit, attach cover plate with 4 screws.
3. Attach left shroud panel using seven screws, 3 on top and bottom and 1 along the side. **Figure 18.3.**

4. Assemble the right corner and right panel pieces using 4 screws prior to attaching to insert. **Figure 18.4.**
5. After assembly, attach the right shroud panel/corner piece assembly to the insert with 3 screws across the bottom and 1 on the side. **Figure 18.4.**

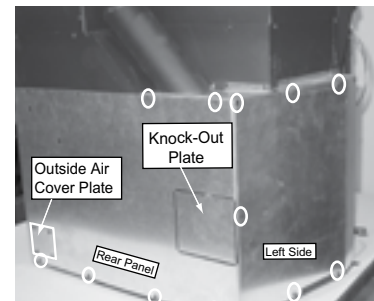

Figure 18.3

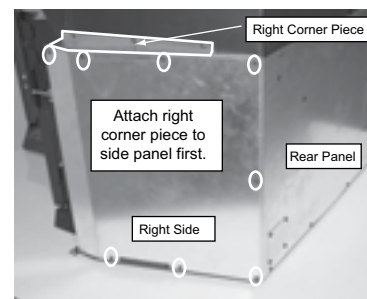

Figure 18.4

Attaching Shroud to Hopper Body:

6. Beginning at the right shroud panel drill into hopper body through the 3 pre-drilled openings and the 2 pre-drilled openings on the rear shroud panel. **Figure 18.5.** Continue around to left shroud corner panel at the 2 pre-drilled openings. **Figure 18.6.** Secure with screws to insert.
7. **For Top Vent Installation:** Install 3 inch or 4 inch (76 or 102mm) top vent adapter. See circled area in **Figure 17.3** on page 17. **NOTE:** This adapter may be attached to outside venting prior to latching it on to the top vent pipe.

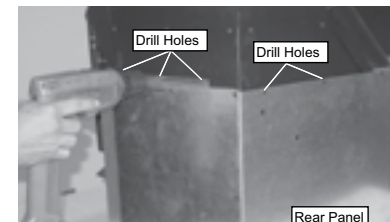

Figure 18.5



Figure 18.6

B. Outside Air Kit Instructions

Parts Included in Kit: 1 piece of 2 inch x 3 ft. flex hose, 1 hose clamp and 1 rodent screen.

Tools Needed: Phillips head screw driver; wire cutters; hole saw or jig saw.

1. Measure distance from floor to air vent opening in appliance and mark location on wall.
2. Use saw to cut opening in wall. Cut a 2-1/2 to 3 inches (64-76mm) opening on inside wall and a 3 to 3-1/2 inch (76-89mm) opening on outside of house.
3. Use hose clamp to secure flex pipe to collar assembly.
4. Slide trim ring over flex pipe and run pipe through wall.
5. Attach hose to outside termination cap with second hose clamp.
6. Secure termination cap to outside surface.
7. Secure trim ring to interior wall.

CAUTION
Never draw outside combustion air from: <ul style="list-style-type: none"> • Wall, floor or ceiling cavity • Enclosed space such as an attic or garage

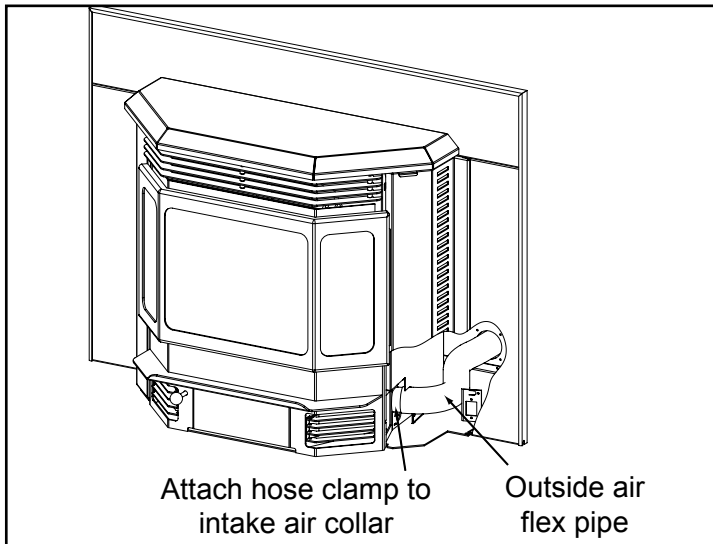

Figure 19.1

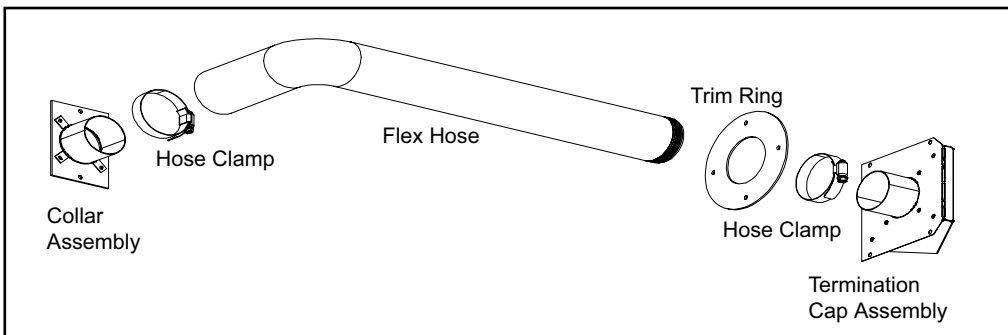

Figure 19.2

C. Adjustable Hopper Options

Depending on your installation, the hopper can be vertically adjusted up to a maximum of 3-1/2 inches (89mm) and will hold an additional 15 lbs of fuel.

To adjust hopper:

1. Using a Phillips head screw drive, remove all the screws from the top of the hopper securing the top hopper piece to the bottom hopper piece and insert body.
2. Adjust upward a maximum of 3-1/2 inches (89mm).
3. Mark location for new holes and drill new holes.
4. Secure hopper pieces together using screws removed in step one.
5. See drawing on **page 7, Figure 7.3.**

D. Optional Grille Installation

1. Remove grille from packaging.
2. Lift top up.
3. Align the 3 holes in the insert with the holes in the grille.
4. Use a Phillips screw driver to secure in place. It will be necessary to go through the hole in the bag support shelf to gain access to the screw. **Figure 19.3.**
5. Lower the top into position.

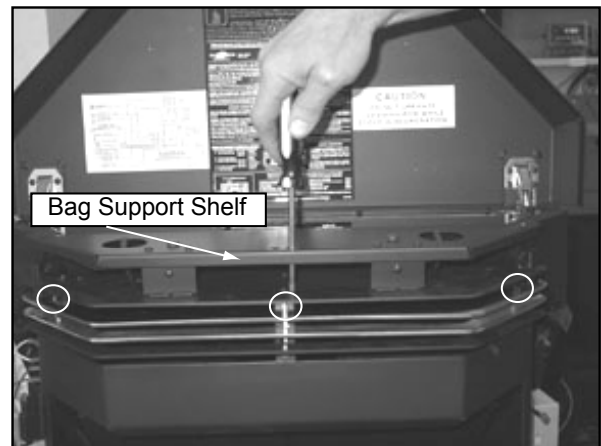

Figure 19.3

E. Adjustable Hearth Support

Size: 9”d x 45”w, 2” to 10” Height Adjustment

Included in Kit: (1) trim top, (1) trim front, (2) trim sides, double-sided tape (already installed)

Tools Needed: Phillips head screw driver, sheet metal shears, measuring tape, gloves

1. The 10 screws on each set of scissors will already be loose when shipped. **Figure 20.1.**
2. Expand scissors to desired height. Tighten screws to hold in place using Phillips head screw driver. **Figure 20.2.**
3. Measure front and side trims to required height to cover scissors and mark pieces for cutting. Cut excess material from **top** of trim’s edge, not bottom. This edge will be sharp; wear gloves to prevent injury to your hands. **Figure 20.3.**
4. Using sheet metal shears, cut trim along the marked edge. The cut edge fits under lip of top trim, so it allows for some variance in your straight edge.
5. The double-sided tape that holds front and side trims to scissors has a powerful bonding adhesive. Adjustments are extremely difficult once trim has adhered to tape. Do a dry run first without removing paper from tape.
6. Place cut edge of trim under top lip and into position on scissors. Place side pieces on first and then front piece. The front piece overlaps side pieces.
7. Once you are satisfied with the positioning, remove trim and set aside.
8. Remove the paper from double-sided tape that is to accept trim side. Align side and then press hard against tape to secure side piece. Repeat for other side. Install front trim piece last.
9. There are 3 holes in the back flange of the top to secure it to the wall if necessary. Use the appropriate fastener for the type of wall material, i.e., brick, sheetrock, etc.

NOTE: 3/8 inch (9.5mm) thick tile or like material can be cut to size and fit under lip of top trim edge for a decorative touch. **Figure 20.3.**

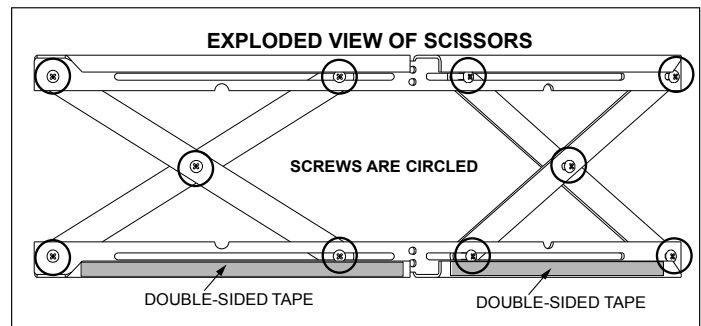

Figure 20.1

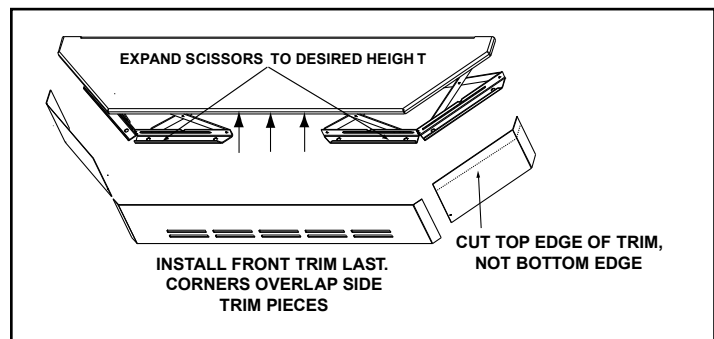

Figure 20.2

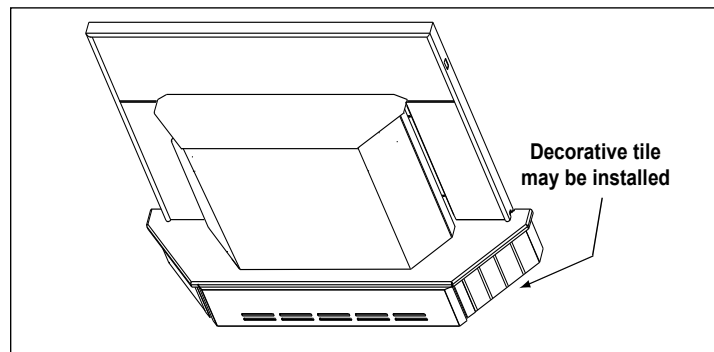



Figure 20.3

	 <p>WARNING</p>
<p>Sheet metal trim edges will be sharp. For safety purposes wear gloves. Injury can occur.</p>	

F. Panel and Trim Set

Standard Size: 30”H x 40” W (762mm x 1016mm)

Large Size: 33” H x 50” W (838mm x 1270mm)

Included in Kit: 2 side panels, 1 top panel, 2 side trim, 1 top trim, 2 corner brackets and fastener package.

Tools Needed: Phillips and flat head screw drivers.

1. Unpack and lay out parts face down (flanges up) on a non-abrasive surface as shown in **Figure 21.1**. Install (1) 8-32 x 3/8” screw into bottom tab of side panel.
2. Set the large hole at bottom of side curtain over screw installed in **Figure 21.2**. Stand assembly on end and attach and install (1) 8-32 x 3/8” screw through tab in side panel and curtain. Lay face down as shown in **Figure 21.3**
3. Align top panel to side panel setting clearance hole over screw head in side panel/curtain assembly.
4. Install (2) 8-32 x 3/8” screws through holes in side panel into top panel. Complete for both sides.

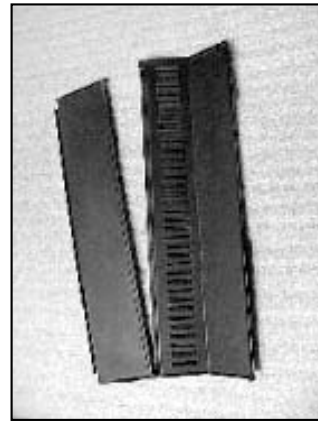

Figure 21.3

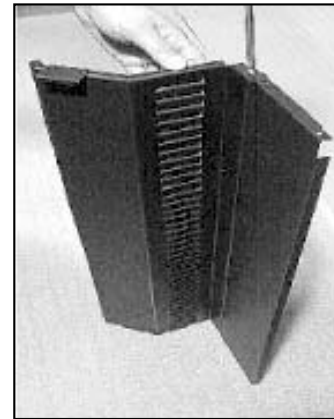

Figure 21.4

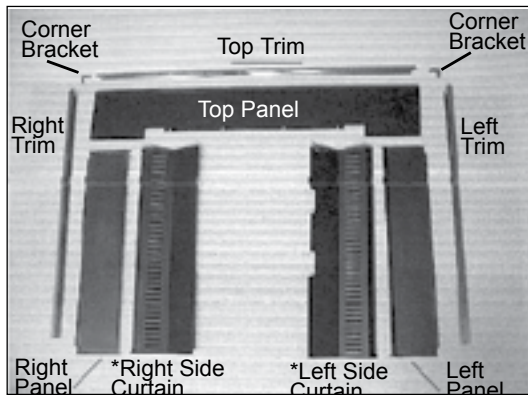

Figure 21.1 *Right and left side curtains are shipped with the insert.

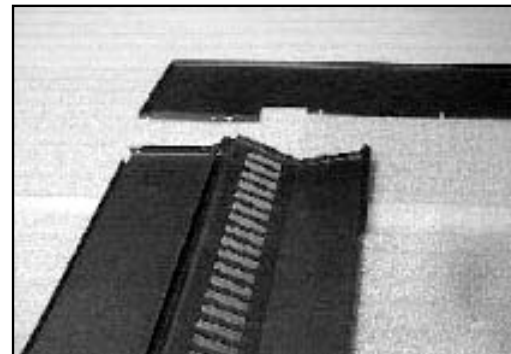

Figure 21.5

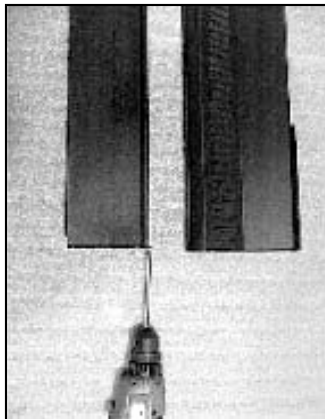

Figure 21.2



Figure 21.6

F. Panel and Trim Set (Cont'd)

7. Hold side curtains in open position and lower panel set over insert setting lower edge of top panel in slot between hopper lid and panel support as shown in **Figure 22.1**. Place existing screw head (installed in **Figure 21.2**) into locator hole in floor of insert. **See Figure 22.2**.
8. Lift hopper lid and press down on panel top while installing (4) 8-32 x 3/8" screws into holes in panel support. (If screws have been factory installed, tighten to secure panel to panel support.) Return hopper lid to closed position.
9. Install a corner bracket on each side trim piece. Slide brackets into top trim from each side and secure with flathead screwdriver. Attach trim assembly to panel set as follows:
 - a. Ensure that brackets face towards the back.
 - b. Align trim assembly to panel set sides and slide down.

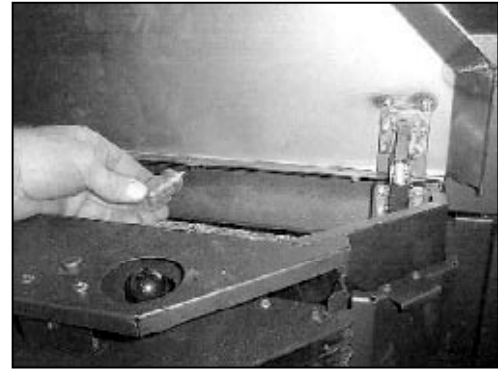

Figure 22.3



Figure 22.1

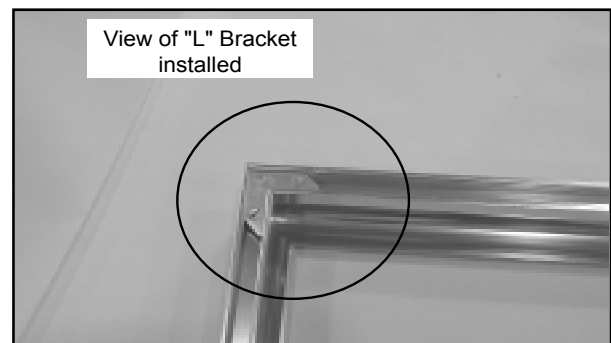

Figure 22.4



Figure 22.2



Figure 22.5- Completed View

G. Optional Log Set Placement Instructions

CAUTION

Logs are FRAGILE. Use extreme care when handling or cleaning logs.

1. Place the front log in first as shown in **Figure 23.1**. Place log between firepot and face of appliance with charred area surrounding firepot.
2. Set the left and right twigs onto the log, placing the holes in the base of twigs over the locating pins in log. See **Figure 23.2**. Ensure that the charred ends are facing the firepot.

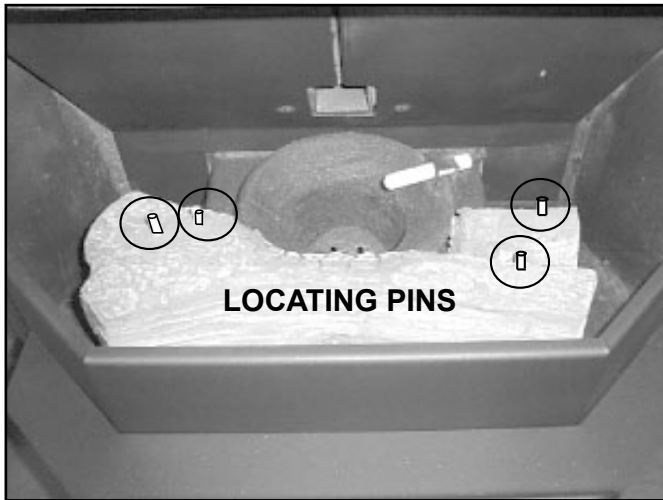

Figure 23.1

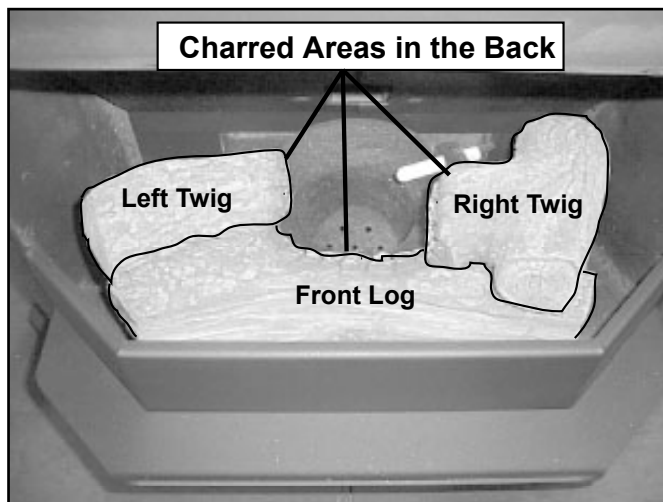

Figure 23.2

NOTE:

Due to the abrasive nature of a pellet appliance fire, the logs are not covered under warranty. Any placement variation other than shown here can cause excessive heat and shall void the appliance warranty.

H. Thermostat Installation

1. A 12 volt AC thermostat is required to operate this pellet appliance. You may use the included wall mount thermostat or purchase an optional programmable thermostat or remote control. The included thermostat is equipped with an adjustable heat anticipator. The current rating is .05 amps. The anticipator needs to be adjusted to the lowest setting available.
2. When mounting a thermostat on a wall, be sure to follow your thermostat installation instructions carefully.

NOTE: Thermostat must be mounted level for accurate readings. The thermostat should be mounted on an inside wall and not in direct line with the appliance convection air. Remove any packaging from inside the thermostat before using.

NOTE: If the thermostat is located too close to the appliance, you may need to set the temperature setting slightly higher to maintain the desired temperature in your home.

3. Open right side plane to access a 4 screw terminal block located on the bottom right hand side next to the power cord inlet. The center 2 screws are for the thermostat wires. The outer 2 are the mounting screws for the terminal block. **Figure 23.1**.



CAUTION

Shock hazard.

- Do NOT remove grounding prong from plug.
- Plug directly into properly grounded 3 prong receptacle.
- Route cord away from appliance.
- Do NOT route cord under or in front of appliance.

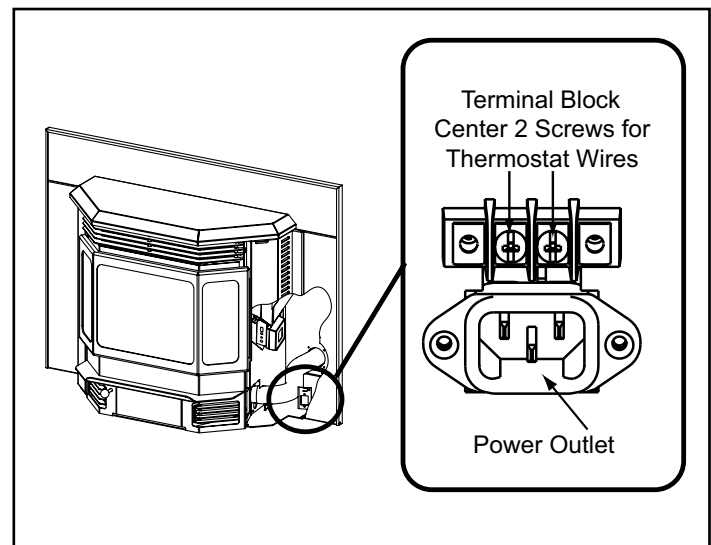

Figure 23.3

8

Operating Instructions

A. Fuel Size And Material

1. Wood Pellets

Fuel pellets are made from sawdust or wood by-products. If the source material is hardwood, they can have a higher mineral content, creating more ash. Fuels containing bark will also have higher ash content. Minerals and other noncombustible materials such as sand will turn into a hard, glass-like substance called a clinker when heated to the extreme temperatures our firepot reaches. This is what forms clinkers in the bottom of the firepot. Trees from different areas will vary in mineral content. That is why some fuels produce more clinkers than others. Pellets are manufactured in either 1/4 inch or 5/16 inch (6-8mm) diameter and should be **no more than 1-1/2 inches (38mm) in length**. Pellet lengths may even vary by lot from the same manufacturer which is why the feed rate may need to be adjusted occasionally. **If you burn pellets longer than 1-1/2 inches (38mm) you may have an inconsistent fuel feed rate and/or missed ignitions.**

Pellet fuel quality can greatly fluctuate. We recommend using premium grade fuel with ash content less than 1%. Even in some fuel labeled "premium" ash content can vary from bag to bag and possibly exceed 1%. High ash fuel, or lack of maintenance, can cause the firepot to fill up and thus create a potential for smoking, sooting and possible hopper fires.

Always burn dry fuel. Burning fuel with high moisture content takes heat from the fuel and tends to cool the appliance, robbing heat from your home. Damp pellet fuel can clog the feed system.

We recommend that you buy fuel in multi-ton lots whenever possible. Buying large quantities of fuel at once will greatly reduce the number of times the feed adjustments will need to be made. However, we do recommend trying various brands before purchasing multi-ton lots to ensure your satisfaction.

WARNING

Fire Risk.

- High ash fuels, or lack of maintenance, can cause the firepot to fill with ash and clinker. If the firepot fills to the top, immediately shut down the unit and clean.
- Failure to do so could result in smoking, sooting and possible hopper fires.

2. Shelled Field Corn

Shelled field corn can be an efficient and economical fuel. We recommend using a 50-50 blend of corn and wood pellets. The only change in operation; 1) the feed rate may require a slight adjustment and 2) firepot will require more frequent cleanings. The BTU output varies slightly compared to pellets, depending on the quality of the corn used. In cases where it is acceptable for the appliance to run full time, 100% corn will work after the fire has been started using wood pellets.

B. General Operating Information

1. Thermostat Calls For Heat

The appliance is like most modern furnaces; when the thermostat calls for heat, your appliance will automatically light and deliver heat. When the room is up to temperature and the thermostat is satisfied, the red call light will shut off and the appliance will shut down. **Figure 24.1.**

2. Heat Output Controls

This appliance is equipped with a heat output control switch that has three settings or burn rates; low, medium and high. The appliance will turn on and off as the thermostat demands. When the thermostat calls for heat, the appliance will always start up on High. After burning approximately 4 minutes, the appliance will then burn at the rate at which it was originally set. If the appliance is set at one of the lower settings, it will run quieter but takes longer to heat up an area than if it were set at a higher burn rate. Regardless of the burn rate, when the area is warm enough to satisfy the thermostat, the appliance will shut off.

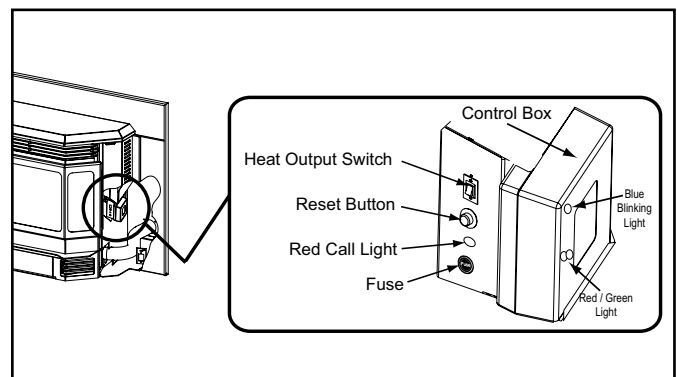

Figure 24.1

WARNING

Fire Risk.

Keep combustible materials, gasoline and other flammable vapors and liquids clear of appliance.

- Do NOT store flammable materials in the appliance's vicinity.
- Do NOT use gasoline, lantern fuel, kerosene, charcoal lighter fluid or similar liquids to start or "freshen up" a fire in this heater.
- Keep all such liquids well away from the heater while it is in use.
- Combustible materials may ignite.

C. Before Your First Fire

1. First, make sure your appliance has been properly installed and that all safety requirements have been met. Pay particular attention to the fire protection, venting and thermostat installation instructions.
2. Double check that the ash pan and firebox are empty!
3. Check the position of the thermocouple, located above the firepot, and make sure that it protrudes approximately 3/4 inch (19mm) into the firepot.
4. Close the front door.

CAUTION
<p>Tip of thermocouple must be in contact with the inside end of the thermocouple cover.</p> <p>Missed ignitions can occur.</p>

D. Fuel Adjustment Control Rod

The set screw is located at the bottom of the hopper and set loose at the factory so the fuel adjustment control rod will slide by only loosening the wing nut. Do not re-tighten bottom set screw.

E. Starting Your First Fire

1. A thermostat is required for proper operation of this appliance, except for corn. At this time, fill the hopper with pellets, set the thermostat to its lowest setting. Plug the power cord into nearby outlet.
2. The exhaust blower will stay on for approximately 10 minutes even though the thermostat is not calling for heat. This is normal.
3. Locate the heat output control switch on the right side behind the right side panel. Set to the HIGH setting and then adjust the thermostat to its highest setting. The red call light will be on which is located on the right side behind the right side panel. This indicates the thermostat is calling for heat. **See Figure 24.1 on page 24.**
4. The fuel feed system and the igniter should now be on.
5. For your first fire it will be necessary to press the reset button approximately 2 minutes after start-up and again at 4 minutes. This will fill the feed system and allow the appliance to begin dropping pellets. Continue pushing the reset button until you detect that pellets are being delivered into the firepot. The appliance will continue to run as long as the thermostat is calling for heat.
6. Once the appliance has ignited, let it burn for approximately 15 minutes, then set the thermostat to the desired room temperature. Adjust the heat output control switch to the desired setting.

F. Fire Characteristics

A properly adjusted fire with the heat output control switch set on "HIGH" has a short active flame pattern that extends out of the firepot approximately 4 to 6 inches (102-105mm). If the fire has tall flames with black tails and seems somewhat lazy, the feed rate will need to be reduced. If the fire is not 4 inches to 6 inches (102-105mm) tall, increase the feed rate. A medium and low setting will give a shorter flame. The flame will rise and fall somewhat. This is normal.

G. Feed Rate Adjustment Instructions



The feed adjustment control rod is factory set, and should be adequate for most fuels. However, if the flame height is too high or too low, you will need to adjust the feed rate. Wait until the appliance has been burning for 15 minutes before making your adjustments and allow 15 minutes for feed adjustment to take effect.

1. Open the hopper lid and locate the fuel adjustment control rod.
2. Loosen the wing nut on the rod.
3. Adjust the fuel adjustment control rod towards the "+" symbol to increase the feed rate and flame height or towards the "-" symbol, to decrease the feed rate and flame height. Make approximately 1/2 inch (13mm) movements of rod at a time.
4. Re-tighten the wing nut.

H. Ignition Cycles

1. During each ignition cycle, it is normal to see some smoke in the firebox. The smoke will stop once the fire starts.
2. The convection blower will automatically turn on after your appliance has reached the set temperature. This blower transfers heat from your appliance into the room, and will continue to run after the thermostat has stopped calling for heat until the appliance has cooled down.
3. Occasionally the appliance may run out of fuel and shut itself down. When this happens, the red call light will be on. To restart it, fill the hopper and press the reset button. When you press the reset button the red call light will go out. Release the button and the light will come back on. You should see a fire shortly. If not, follow the instructions "Starting Your First Fire" on this page.

CAUTION
<p>Odors and vapors released during initial operation.</p> <ul style="list-style-type: none"> • Curing of high temperature paint. • Open windows for air circulation. <p>Odors may be irritating to sensitive individuals.</p>

	<p>WARNING</p>
	<p>Fire Risk Do NOT operate appliance:</p> <ul style="list-style-type: none"> • With appliance door open. • Firepot floor open. • Cleaning slide plates open. <p>Do NOT store fuel:</p> <ul style="list-style-type: none"> • Closer than required clearances to combustibles to appliance • Within space required for loading or ash removal.

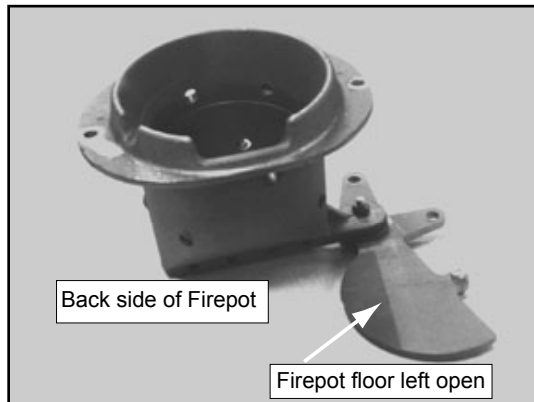

Figure 25.1 - DO NOT LEAVE FIREPOT FLOOR OPEN

I. Frequently Asked Questions

ISSUES	SOLUTIONS
1. Metallic noise.	1. Noise is caused by metal expanding and contracting as it heats up and cools down, similar to the sound produced by a furnace or heating duct. This noise does not affect the operation or longevity of your appliance.
2. Ash buildup on glass.	2. This is normal. Clean the glass.
3. Glass has turned dirty.	3. Excessive build up of ash. The lower burn settings will produce more ash, the higher burn settings produce less. The more it burns on low the more frequent cleaning of the glass is required.
4. Fire has tall flames with black tails and is lazy.	4. The feed rate needs to be reduced or the firepot needs cleaning. Heat exchanger or exhaust blower needs cleaning.
5. Smokey start-up or puffs of smoke from the airwash.	5. Either the firepot is dirty or there is too much fuel at start-up and not enough air. Close down feed rate 1/4 inch (6mm) at a time until this no longer happens.
6. Large flame at start-up.	6. This is normal. Flame will settle down once the fire is established.

9 Troubleshooting

With proper installation, operation, and maintenance your appliance will provide years of trouble-free service. If you do experience a problem, this troubleshooting guide will assist a qualified service person in the diagnosis of a problem and the corrective action to be taken. This troubleshooting guide can only be used by a qualified service technician.

Symptom	Possible Cause	Corrective Action
Plug in appliance - No response.	No current to outlet. .7 amp fuse defective. #3 snap disc tripped or defective. Control box defective.	Check circuit breaker at service panel. Replace fuse. Reset or replace snap disc. Replace control box.
Call light on. No fire. No fuel in firepot.	Out of fuel. #2 snap disc may be defective. Vacuum switch not closing, no vacuum. Control box defective.	Check hopper. Fill with fuel. Replace snap disc. Check exhaust blower is plugged in and operating. Check vacuum switch is plugged in. Check vacuum hose is in good condition, clear and connected at both ends. Check thermocouple is in good condition and plugged in properly. Make sure venting system is clean. Make sure front door is closed. Replace control box.
Call light on. No fire. Partially burned fuel in firepot.	Firepot clean-out plate not closed. Firepot is dirty (missed ignition).	Check that firepot clean-out plate is fully closed. Clean firepot. Make sure there is no clinker in the firepot. Clinkers may have to be broken up with firepot scraper tool or other means.
Call light on. No fire. Unburned pellets in firepot.	Firepot clean-out plate not closed. Firepot is dirty. Ignition hole blocked. Igniter not working. Control box defective.	Check that firepot clean-out plate is fully closed. Clean firepot. Make sure there is not a clinker in the firepot. Clinkers may have to be pushed out of firepot with firepot scraper tool or other means. Scrape with solid piece of wire. Remove ash pan to see if igniter is glowing red on start-up. Check igniter wires for good connection. Replace igniter using 1/4 inch male /female spade connectors. Replace control box.
Slow or smoky start-up.	Firepot clean-out plate not closed. Firepot is dirty. Excessive amount of fuel at start-up.	Check that firepot clean-out is fully closed. Clean firepot. Make sure there is not a clinker in the firepot. Clinkers may have to be pushed out of firepot with firepot scraper tool or other means. Reduce feed rate using feed rate adjustment control rod located inside hopper.

Symptom	Possible Cause	Corrective Action
Slow or smoky start-up (Cont'd)	Dirty exhaust and/or venting system.	Check for ash build up in appliance, including behind rear panels, firebox, heat exchanger, exhaust blower and venting.
Feed system fails to start.	<p>Out of fuel.</p> <p>#2 snap disc may be defective.</p> <p>Vacuum switch not closing. No vacuum.</p> <p>Feed system jammed or blocked.</p> <p>Feed spring not turning with feed motor.</p> <p>Feed motor defective or not plugged in.</p>	<p>Check hopper, fill with fuel.</p> <p>Replace snap disc. Firebox door must be closed securely.</p> <p>Check exhaust blower is plugged in and operating.</p> <p>Check vacuum switch is plugged in.</p> <p>Check vacuum hose is in good condition, clear and connected at both ends.</p> <p>Check thermocouple is in good condition and plugged in properly.</p> <p>Make sure venting system is clean.</p> <p>NOTE: High winds blowing into the venting system can pressurize the firebox causing loss of vacuum.</p> <p>Empty hopper of fuel. Use a wet/dry vacuum cleaner to remove remaining fuel, from hopper, including feed tube.</p> <p>Check feed chute for obstructions.</p> <p>Loosen 2 screws and jiggle feed assembly.</p> <p>Check that set screw is tight on feed spring shaft at end of feed motor.</p> <p>Check connections on feed motor, replace if defective.</p>
No call light. Appliance does not begin start sequence.	<p>Thermostat not set to a high enough temperature.</p> <p>Snap Disc #3 tripped.</p> <p>No power.</p> <p>Fuse blown.</p> <p>Connections at thermostat and/or appliance not making proper contact.</p> <p>Defective thermostat or thermostat wiring.</p> <p>Control box defective.</p>	<p>Adjust thermostat above room temperature.</p> <p>Reset snap disc.</p> <p>Connect to power.</p> <p>Replace fuse.</p> <p>Check connections at thermostat and appliance.</p> <p>Replace thermostat or wiring.</p> <p>NOTE: To test thermostat and wiring, use a jumper wire at the thermostat block on the appliance to by-pass thermostat and wiring.</p> <p>Replace control box.</p>
Appliance fails to shut off.	Call light on.	<p>Turn thermostat off.</p> <p>If call light does not go out, disconnect thermostat wires from appliance. If call light does go out, thermostat or wires are defective.</p>

Symptom	Possible Cause	Corrective Action
Convection blower fails to start.	No call light. #1 snap disc defective. Blower not plugged in. Blower is defective. Control box is defective.	Defective control box. Replace snap disc. Check that blower is plugged into wire harness. Replace blower. Replace control box.
Exhaust blower fails to start or does not shut off.	Blower not plugged in. Blower is clogged with ash. Blower is defective. Control box is defective.	Check that blower is plugged into wire harness. Clean exhaust system. Replace blower. Replace control box.
Large, lazy flame, orange color. Black ash on glass.	Dirty appliance. Poor fuel quality, high ash content. Firepot clean-out plate not completely closed. Excessive amount of fuel.	Clean appliance, including firepot, heat exchangers and venting system. Remove stainless steel baffle from firebox to clean ash from on top of baffle. Clean behind rear brick panels. Change fuel brand to premium. Check that firepot clean-out plate is fully closed. Reduce feed rate using feed rate adjustment control rod located inside hopper.
Nuisance shutdowns.	Low flame. Sawdust buildup in hopper. Feed motor is reversing. Defective thermocouple. Defective control box. Firepot more than 1/2 full	Increase feed by opening feed rate adjustment control rod located inside hopper. Clean hopper, see page 32 . Check for good connections between feed motor and wire harness. Replace thermocouple. Replace control box. See pages 32 & 33 for detailed instructions for "High Ash Fuel Content Maintenance".
Appliance calls for heat. Call light illuminates. Exhaust blower starts. No feed or igniter.	Thermocouple is defective or not properly plugged in. Defective control box	Check connections on thermocouple or replace if defective. A flashing yellow light on the control box indicates a problem with the thermocouple. Replace control box.

10 Maintaining & Servicing Your Appliance

A. Proper Shutdown Procedure



CAUTION

Shock and Smoke Hazard

- Turn down thermostat, let appliance completely cool and exhaust blower must be off. Now you can unplug appliance before servicing.
- Smoke spillage into room can occur if appliance is not cool before unplugging.
- Risk of shock if appliance not unplugged before servicing appliance.

B. General Maintenance

1. Types of Fuel

Depending on the type of fuel you are burning will dictate how often you have to clean your firepot. If the fuel you are burning has a high dirt or ash content or you are burning shelled field corn, it may be necessary to clean the firepot more than once a day. Dirty fuel will cause clinkers to form in the firepot. A clinker is formed when dirt, ash or a non-burnable substance is heated to 2000°F (1093°C) and becomes glass-like. See “C” in this section for more details on fuels with high ash content.

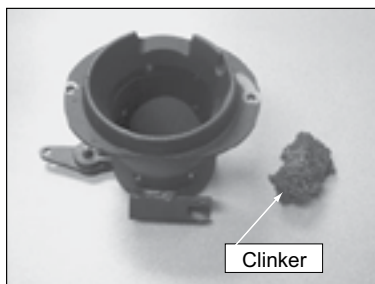

Figure 30.1 - Clinker

2. Cleaning Firepot with Cleaning Rod & Firepot Scraper

- **Frequency:** Daily or more often as needed
- **By:** Homeowner
- **Task:**
 - a. The appliance must be in complete shutdown and cool and the exhaust blower off. If you are just cleaning the firepot, there is no need to unplug the appliance.

- b. Pull firepot cleaning rod OUT and IN a couple of times to help shake debris loose. If rod is hard to pull, it may be necessary to use your firepot scraper to chip away material that has built up on the bottom plate of the firepot and to push out any clinkers. Larger clinkers may have to be removed from the top of the firepot. Corn clinkers can be especially difficult to break up.
- c. The firepot floor plate must be fully closed when finished.

3. Cleaning Ash Pan

- **Frequency:** As needed
- **By:** Homeowner
- **Task:**

Locate the ash pan underneath the firepot and using a slight pull up and out remove the ash pan. Empty into a non-combustible container and re-install ash pan. **See Disposal of Ashes on page 31.**

4. Ash Removal from Firebox

- **Frequency:** Weekly or as needed
- **By:** Homeowner
- **Task:**
 - a. There must not be any hot ashes in the firebox during cleaning so allow the appliance to completely cool. Frequent cleaning of the ash in the firebox will help slow down the build-up of ash in the exhaust blower and vent system.
 - b. Plug in your appliance, if unplugged, and turn the thermostat on and immediately shut it off to start the exhaust blower on its cycle time. It will pull fly ash out the exhaust instead of into the room.
 - c. Open door. Remove ash with an ash vacuum or whisk broom and small dust pan.
 - d. This ash is deposited in the same ash pan as the firepot debris. The ash pan should be emptied every time you clean the firebox. Remember to place the ash and debris into a metal or non-combustible container. **See Disposal of Ashes on page 31.**



WARNING

Fire Risk.

- NEVER pull firepot cleaning rods or cleaning slide plates when appliance is operating. Hot pellets may fall into ashpan and may start a fire or have mis-starts due to lack of vacuum.



WARNING

Disposal of Ashes

- Ashes should be placed in metal container with tight fitting lid.
- Ashes should be retained in closed container until all cinders have thoroughly cooled.

6. Disposal of Ashes

- **Frequency:** As needed
- **By:** Homeowner
- **Task:**

Ashes should be placed in a metal container with a tight-fitting lid. The closed container of ashes should be placed on a non-combustible floor or on the ground, well away from all combustible materials, pending final disposal. If the ashes are disposed of by burial in soil or otherwise locally dispersed, they should be retained in the closed container until all cinders have been thoroughly cooled.

8. Cleaning Beneath Heat Exchanger

- **Frequency:** Monthly or after burning 1 ton of fuel
- **By:** Homeowner
- **Task:**



A more thorough cleaning is needed to remove the excess ash that is left behind from the use of the cleaning rods for the heat exchanger tubes. The ash will be resting on the back of the baffle. This will require removing the baffle. Please refer to **page 34** for instructions on removing the baffles.

9. Cleaning Exhaust Path

- **Frequency:** Yearly or as needed
- **By:** Homeowner
- **Task:**
 - a. Appliance must be completely cool before cleaning glass.
 - b. Open the hinged access door on the left of the insert.
 - c. Reach in and unlatch the trap door that is connected to the rear of exhaust blower.
 - d. Use a small vacuum hose attachment to clean area.
 - e. Re-latch and close trap door.

NOTE: There are heavy duty vacuum cleaners specifically designed for solid fuel appliance cleaning.

 **WARNING**

Heat exchanger cleaning rods may be warm to the touch. For safety purposes wear gloves.

Do not pull heat exchanger cleaning rods while appliance is operating.

Push cleaning rods IN when done, DO NOT leave cleaning rods OUT. Injury can occur.

7. Cleaning Heat Exchanger Chambers

- **Frequency:** Weekly or as needed
- **By:** Homeowner
- **Task:**

The amount of ash buildup in the firepot will be a good guide to determine how often you should clean the heat exchangers.

- a. Allow the appliance to completely cool down before pulling the cleaning rods. Turn the thermostat on and then immediately off to start the exhaust blower on its cycle time. It will pull fly ash out the exhaust instead of into the room.
- b. To access the cleaning rods lift the hopper lid. Both black bent handle pull rods are located close to the face of the appliance to the left and right side.
- c. To clean, pull the rods straight out until it stops, approximately 20 inches (508mm). Slide the rods OUT and IN a couple of times.

10. Cleaning the Glass

- **Frequency:** As needed
- **By:** Homeowner
- **Task:**
 - a. Appliance must be completely cool before cleaning glass.
 - b. Use a damp paper towel or any nonabrasive glass cleaner. Wipe off with dry towel.

 **CAUTION**

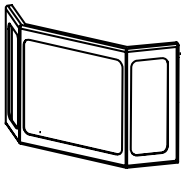

Handle glass assembly with care.

When cleaning glass:

- Avoid striking, scratching or slamming glass.
- Do NOT clean glass when hot.
- Do NOT use abrasive cleaners.
- Use a hard water deposit glass cleaner on white film.
- Refer to maintenance instructions.

 **WARNING**

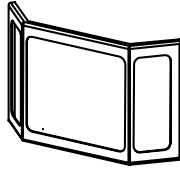

Handle glass with care.

- Inspect the gasket to ensure it is undamaged.
- Do NOT strike, slam or scratch glass.
- Do NOT operate appliance with glass assembly removed.

Do NOT operate with glass cracked, broken or scratched.

11. Door Latch Inspection

- **Frequency:** Periodically
- **By:** Homeowner
- **Task:**

To adjust, open the latch and pivot the holding rod out. Loosen the jam nut on the rod. With a Phillips head screw driver, turn the rod clockwise to tighten. The latch handle should snap securely in place when adjusted properly. After adjusting the latch, be sure to tighten the jam nut on the rod to hold the adjustment.

12. Door Gasket Inspection

- **Frequency:** Periodically
- **By:** Homeowner
- **Task:**

To inspect the door rope (gasket), open the door and see that the door rope extends approximately 1/8" (3mm) to 3/16" (9.5mm) from the door rope channel. It should show signs of compaction all the way around the door where the rope contacts the face of the insert. Confirm there are no air leaks.

13. Cleaning the Hopper

- **Frequency:** Monthly or after burning 1 ton of fuel
- **By:** Homeowner
- **Task:**

After burning approximately 1 ton of fuel you will need to clean the hopper to prevent sawdust build-up. A combination of sawdust and pellets on the auger reduces the amount of fuel supply to the firepot. This can result in nuisance shutdowns and mis-starts.

- The appliance must be in complete shutdown. Allow the appliance to completely cool down.
- Empty the hopper of any remaining pellets.
- Vacuum the hopper and feed tube.

14. Cleaning Exhaust Blower - Requires No Lubrication

- **Frequency:** Yearly or as needed
- **By:** Quality Service Technician/Homeowner
- **Task:** **Contact your local dealer.**

15. Cleaning Convection Blower - Requires No Lubrication

- **Frequency:** Yearly or as needed
- **By:** Qualified Service Technician
- **Task:** **Contact your local dealer.**

16. Soot and Fly Ash: Formation & Need for Removal in Exhaust Venting System.

- **Frequency:** Yearly or as needed
- **By:** Qualified Service Technician/Homeowner
- **Task:**

The products of combustion will contain small particles of fly ash. The fly ash will collect in the exhaust venting system and restrict the flow of the flue gases. At start-up if there is incomplete combustion, or if there is a shutdown or incorrect operation of the appliance it will lead to some soot formation. This will collect in the exhaust venting system.

The venting system may need to be cleaned at least once a year or more often depending upon the quality of your fuel or if there is a lot of horizontal pipe sections. Ash will build up more quickly in the horizontal sections.

C. High Ash Fuel Content Maintenance

- **Frequency:** As needed
- **By:** Homeowner
- **Task:**

Poor quality pellet fuel, or lack of maintenance, can create conditions that make the firepot fill quickly with ashes and clinkers. This condition makes the appliance susceptible to overflowing the firepot with pellets which may result in smoking, sooting and possible hopper fires. **Figure 33.1** shows an example where the firepot overfills, pellets back up into the feed tube and ash has accumulated in the firebox. On page 33 **Figure 33.2** illustrates an inefficient and non-economical method of burning of fuel caused by poor quality pellet fuel. **Figure 33.3** is showing the correct flame size when good quality, premium pellet fuel is burned.

If the ash buildup exceeds the half way point in the firepot **IMMEDIATE ATTENTION AND CLEANING IS REQUIRED.**

Follow the detailed instructions found in this section for each step listed below.

- Shut down the unit by turning down the thermostat and allow unit to completely cool down. (Do not unplug the unit, it can cause smoke spillage in the room).
- Pull the heat exchanger cleaning rods. **Section 10.7**
- Empty the firepot. **Section 10.2**
- Clean the firebox. **Section 10.4**
- Empty the ash pan **Section 10.3**
- Dispose of the ashes. **Section 10.6**
- Restart the appliance with premium grade fuel.

D. Igniter Replacement

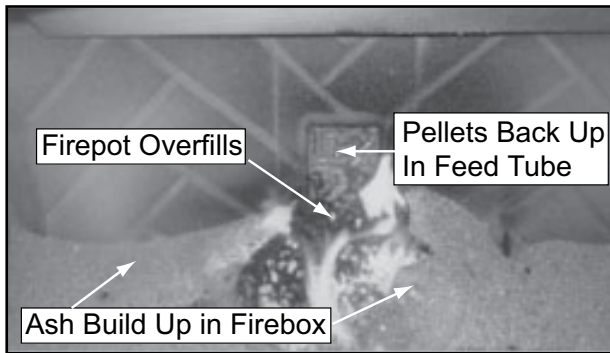

Figure 33.1

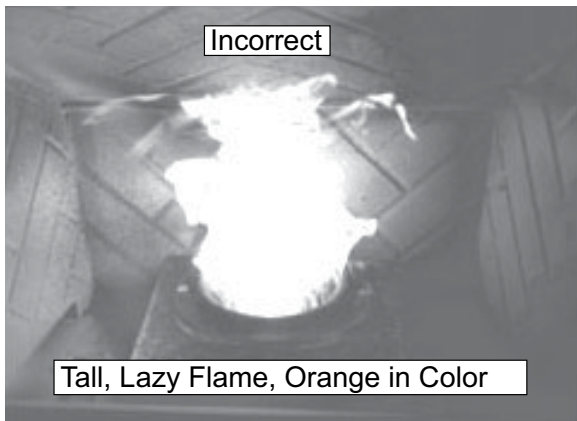

Figure 33.2

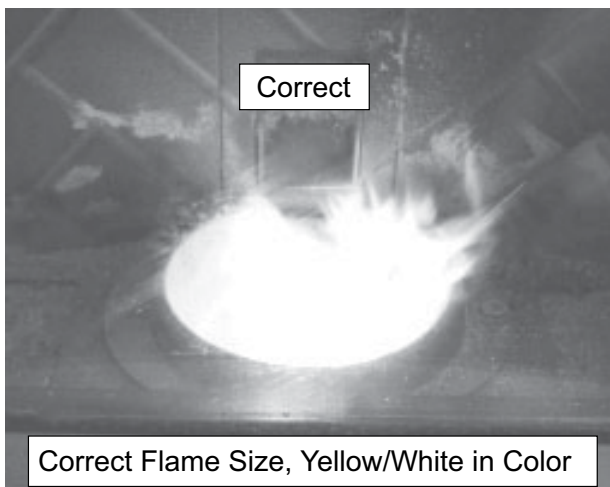

Figure 33.3

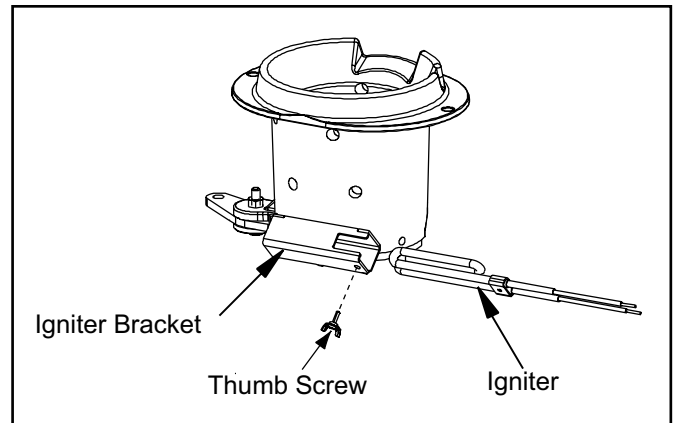

Figure 33.4

- a. Shut down the appliance by turning down the thermostat and let the appliance completely cool down. After the appliance has cooled down, unplug it and remove the ash pan.
- b. The wire leads to the igniter are connected to the wire harness with 1/4 inch male / female spade connectors. These wires will pull forward approximately 4 to 5 inches (102mm to 127mm). Disconnect the spade connections and remove the igniter from the chamber. Loosen the thumb screw and slide igniter out.
- c. Install new igniter into the chamber and tighten the thumb screw. Re-connect the wires to the 2 leads with the spade connectors.
- d. Push excess wire leads to take-up the 4 to 5 inches (102mm to 107mm) previously pulled out. This will keep the wires out of the way of the ash pan. Double check that the igniter wires are clear of any movement, i.e. ash pan, firepot cleaning rod, etc.
- f. Re-install the ash pan and re-connect the power.

	WARNING
	<p>Fire Risk.</p> <ul style="list-style-type: none"> • High ash fuels, or lack of maintenance, can cause the firepot to fill with ash and clinker. If the firepot fills to the top, immediately shut down the unit and clean. • Failure to do so could result in smoking, sooting and possible hopper fires.

E. Glass Replacement

 WARNING
 <ul style="list-style-type: none"> • Glass is 5mm thick high temperature heat-resistant ceramic glass. • DO NOT REPLACE with any other material. • Alternate material may shatter and cause injury

- Remove door from appliance and place face down on a protected surface to avoid scratching the door.
- Remove all door rope.

Replacing Center Glass

NOTE: DO NOT LET Air Wash Spacers fall down from top frame when removing and replacing center glass.

1. Using a nut driver remove the (5) bottom nuts and remove the bottom glass frame. **Figure 34.2.**
2. Slightly bend up and out of the way the 2 center posts and slide the glass out the bottom.
3. Slide new glass in, reposition the 2 center posts and re-install bottom glass frame.
4. Re-rope the door.

Replacing Side Glass

NOTE: When removing the side glass with the door latch, you must remove the door latch first before removing the side frame. Use a powered Phillips head screw driver to remove the 4 screws.

1. Remove side glass frame.
2. Loosen the top and bottom frame and slightly bend up and out of the way.
3. Slide glass out the side and slide new glass in.
4. Re-install the side glass frame and tighten the top and bottom frames.
5. Re-install the door latch, if applicable, and re-rope the door.

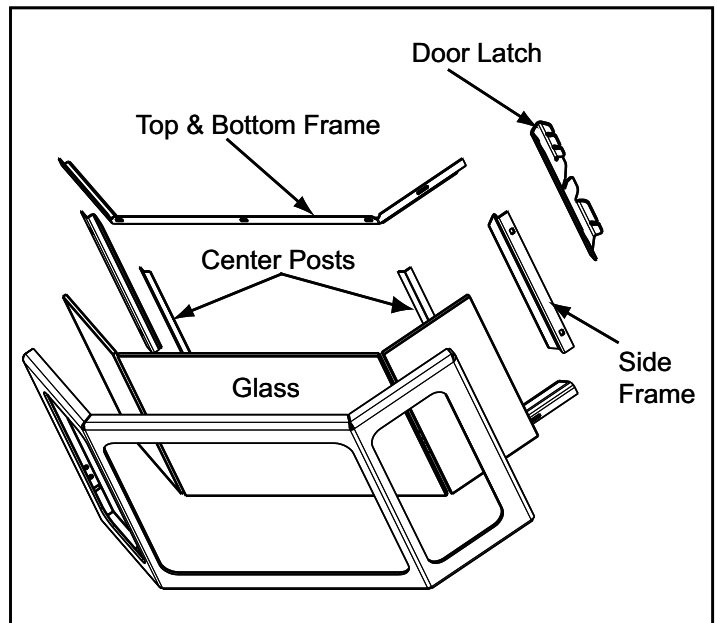

Figure 34.1

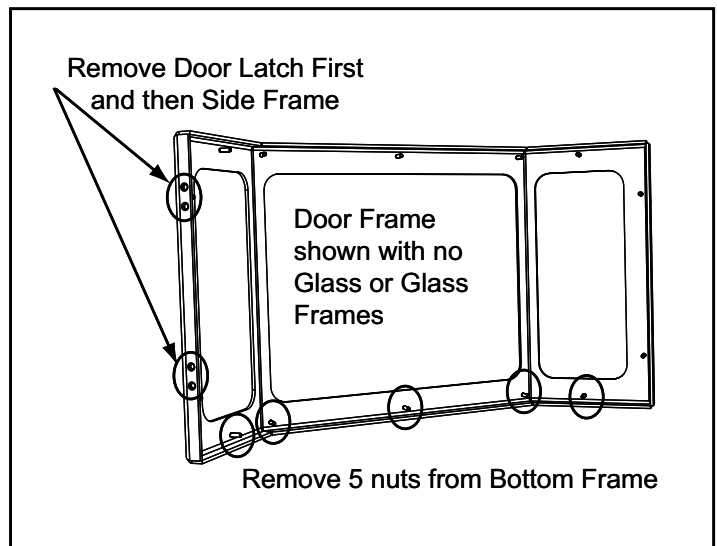

Figure 34.2

F. Baffle Removal

1. Allow appliance to cool completely.
2. Open glass door.
3. Grab the bottom of the baffles and pull up to dislodge from hook attachment.
4. Use a standard screw driver to unlatch the covers beneath the baffles of each side.
5. Re-install in reverse order.

11

Reference Materials



When describing the location of a component part it is always AS YOU FACE THE FRONT OF THE APPLIANCE.

A. Component Function

1. Control Box

- a. The control box is located on right side of appliance, behind the right side panel.
- b. There is a light located inside of the control box. The internal light will turn green when the appliance has reached a temperature of 200°F (93°C) in the firepot. and will turn red when it reaches 600°F (315°C).
- c. There is also an internal blue light located in the upper left corner of the control box. When you plug in the appliance the blue light will automatically start blinking 1 blink every 10 seconds for 60 seconds and then will stop.

NOTE:

Do **NOT** open the control box. This will void the warranty. If you need to plug in or remove the control box you must first **unplug the appliance.**

2. Convection Blower

The convection blower is mounted at the bottom rear of the appliance. There are 2 impellers, one on each side of the motor. The convection blower pushes heated air through the heat exchange system into the room.

3. Exhaust Blower

The exhaust blower is mounted on the left side of the appliance behind the left side panel. It is accessible either when the insert is pulled out onto the hearth or from both hinged side openings. The exhaust blower is designed to pull the exhaust from the appliance and push it out through the venting system.

4. Feed System

The feed system is located behind the firebox and can be removed as an entire assembly. The assembly includes the feed motor, mounting bracket, bearing and feed spring (auger). The hollow feed spring (auger) pulls pellets up the feed tube from the hopper area and drops them down the feed chute into the firepot.

5. Firepot

The firepot is made of high quality ductile iron and has a cleaning pull-out rod. The floor of the firepot opens for cleaning when you pull out the rod. Be sure that the floor returns to a completely closed position or your appliance will not operate properly.

6. Fuse

The fuse is located on the right side of the appliance behind the side panel. The fuse will blow should a short occur and shut off power to the appliance.

7. Heat Exchangers

The heat exchangers transfer heat from the exhaust system into convection air. There are 2 clean out rods located under the heat exchangers.

8. Heat Output Switch

The heat output switch is located on the right side of firebox, behind right side panel. The function of the heat output switch is to regulate the burn rates; low, medium and high settings.

9. Igniter

The igniter is mounted on the base of the firepot. Combustion air travels over the red hot igniter creating super heated air that ignites the pellets.

10. Junction Box And Wiring Harness

The junction box is located on the right side of the appliance, behind the right front access panel. The junction box and wiring harness are replaced as one component.

11. Power Supply

The power outlet is located on the right side of the appliance. Check the wall receptacle for 120 volt, 60 Hz (standard current). Make sure the outlet is grounded and has the correct polarity. A good surge protector is recommended. When operating with a generator you need at least 600 watts of power, or with an inverter at least 800 watts of power, available for the appliance during the start cycle.

12. Red Call Light

The red call light is on the right side behind the right side panel. The function of the red call light is to indicate that the thermostat is calling for heat.

13. Reset Button

The reset button is located on the right side of firebox behind right side panel. The function of the reset button is to momentarily open the thermostat circuit, which restarts the system.

14. Thermocouple

The thermocouple is located on top of the firepot inside the thermocouple cover (ceramic protection tube). The thermocouple sends a millivolt signal to the control box indicating the preset temperatures of the green and red lights have been obtained.

15. Thermostat

The appliance is designed to run on a 12 volt AC thermostat. The heat anticipator, if present, should be set on the lowest setting available.

16. Snap Disc #1 (Convection Blower) 125°F

Snap disc #1 is located on the right side of the firebox. There are 2 purple wires connected to it. This snap disc turns the convection blower on and off as needed. Power is always present at snap disc #1.

17. Snap Disc #2 (Fuel Delivery Interrupt) 200°F

Snap disc #2 is located on the back side of the feed drop tube. There is 1 orange wire and 1 black wire connected to it. This snap disc will turn off the feed system, which will turn off the appliance if an overfire condition should occur or if the convection blower should fail to operate. If this occurs the snap disc will automatically reset itself.

18. Snap Disc #3 (Burn Back Protector) 250°F

Snap disc #3 is mounted on the right side of the auger tube just below feed motor and has a reset button. To access it remove the right side panel. If the fire tries to burn back into the feed system or push exhaust up the feed tube, this snap disc will shut the entire system off. This disc must be manually reset.

19. Vacuum Switch

The vacuum switch is located at the rear of the appliance. This switch turns the feed system on when vacuum is present in the firebox. The vacuum switch is a safety device to shut off the feed motor if the exhaust or the heat exchanger system is dirty or plugged or if the firebox door is open.

20. Wiring Harness

See Figure 36.1 below

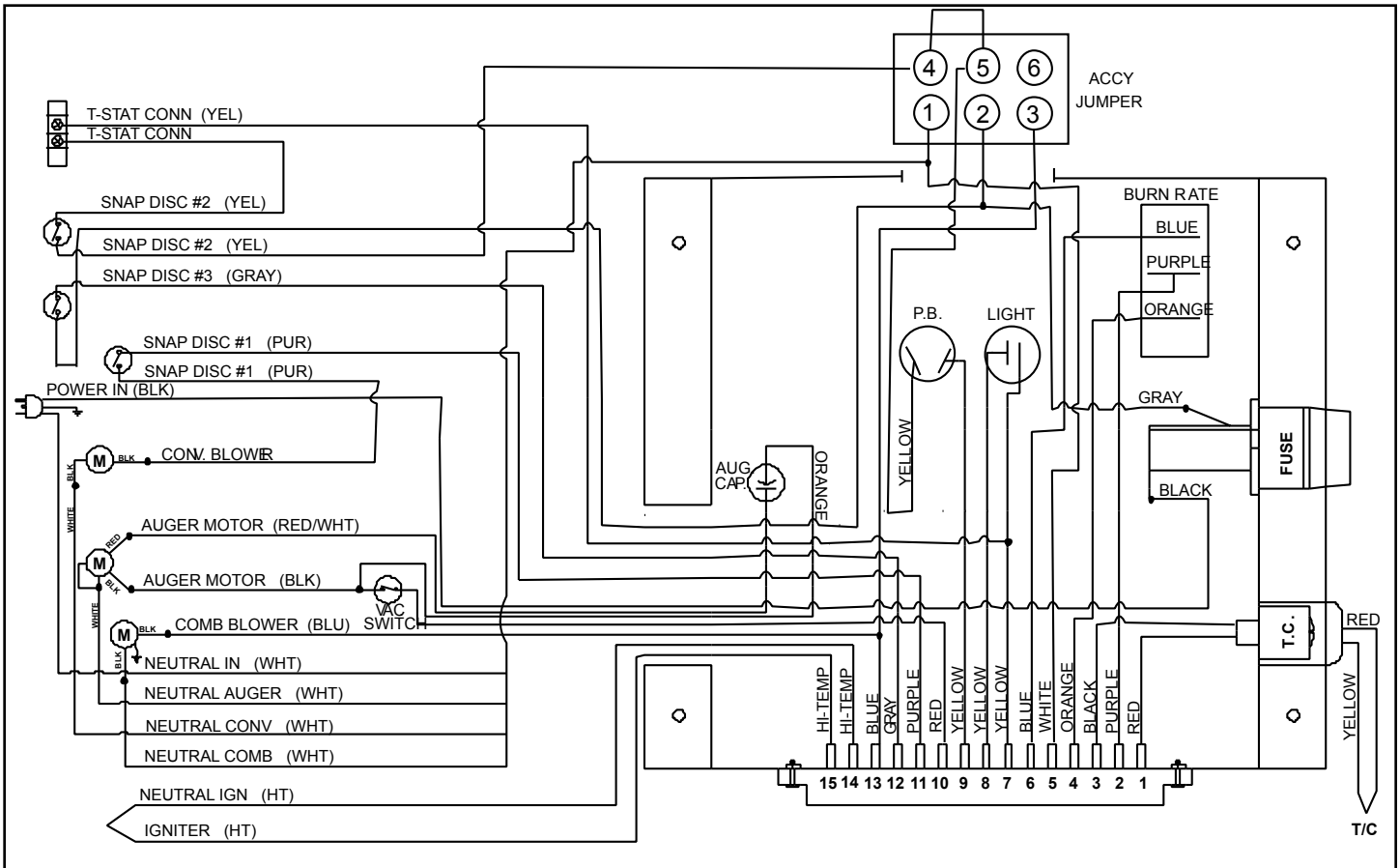

Figure 36.1

B. Component Locations

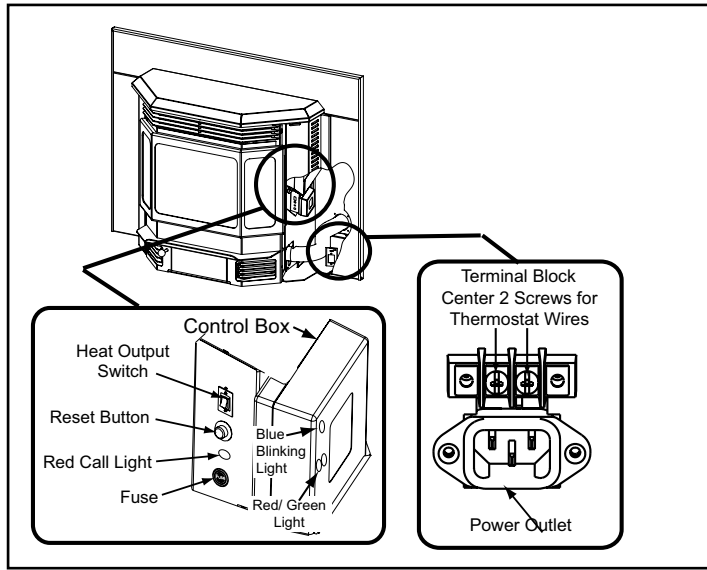

Figure 37.1

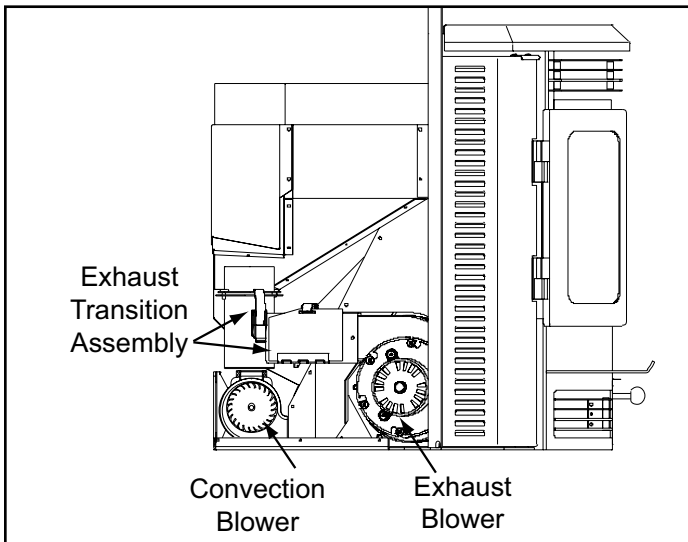

Figure 37.2

C. Exploded Views

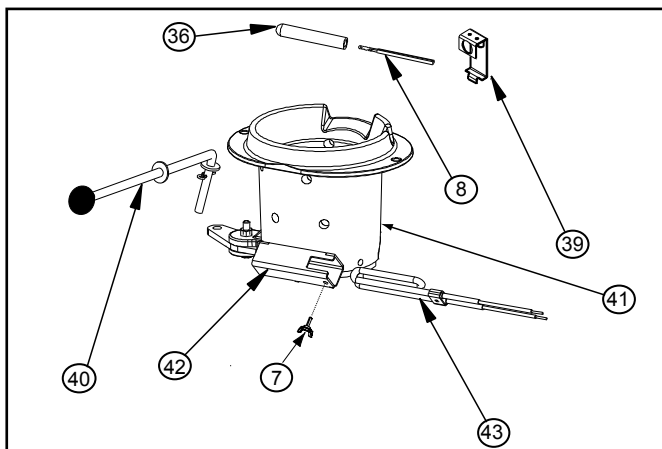

Figure 37.3 - Firepot Assembly

Beginning Manufacture Date: April 8, 1999

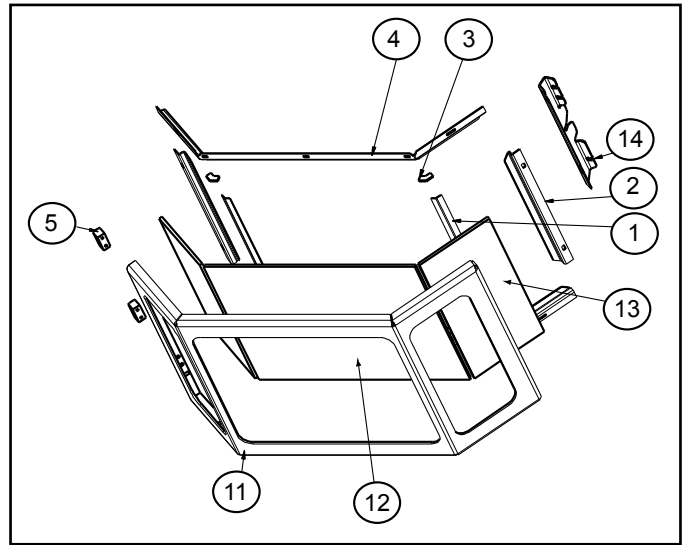

Figure 37.4 - Door, Face, Glass, & Latch Assembly

Nbr	Description	Part Number
11	Door Frame	MBK: 410-6300 Gold: 410-5530 Nickel: 510-5530
12	Glass Assembly, Center	510-5400
13	Glass Assembly, Sides	510-5410
1	Glass Frame Post	410-6240
2	Glass Frame Side	410-4740
14	Door Latch Bracket	410-4912
3	Glass Frame Spacer	410-6250
4	Glass Frame, Top & Bottom	410-4730
5	Hinge, Female	450-2910

Glass Size Center: 13-7/8" wide x 11" high
Glass Size Sides: 5-1/8" wide x 11" high

Nbr	Description	Part Number
40	Firepot Pull Rod (Linkage)	812-4140
42	Igniter Bracket	Not Replaceable
7	Thumb Screw	7000-223
43	Igniter (Heating Element)	7000-226
41	Firepot, EZ Clean	812-3351
39	Thermocouple Holder	812-3171
8	Thermocouple	812-0210
36	Thermocouple Cover	812-1322

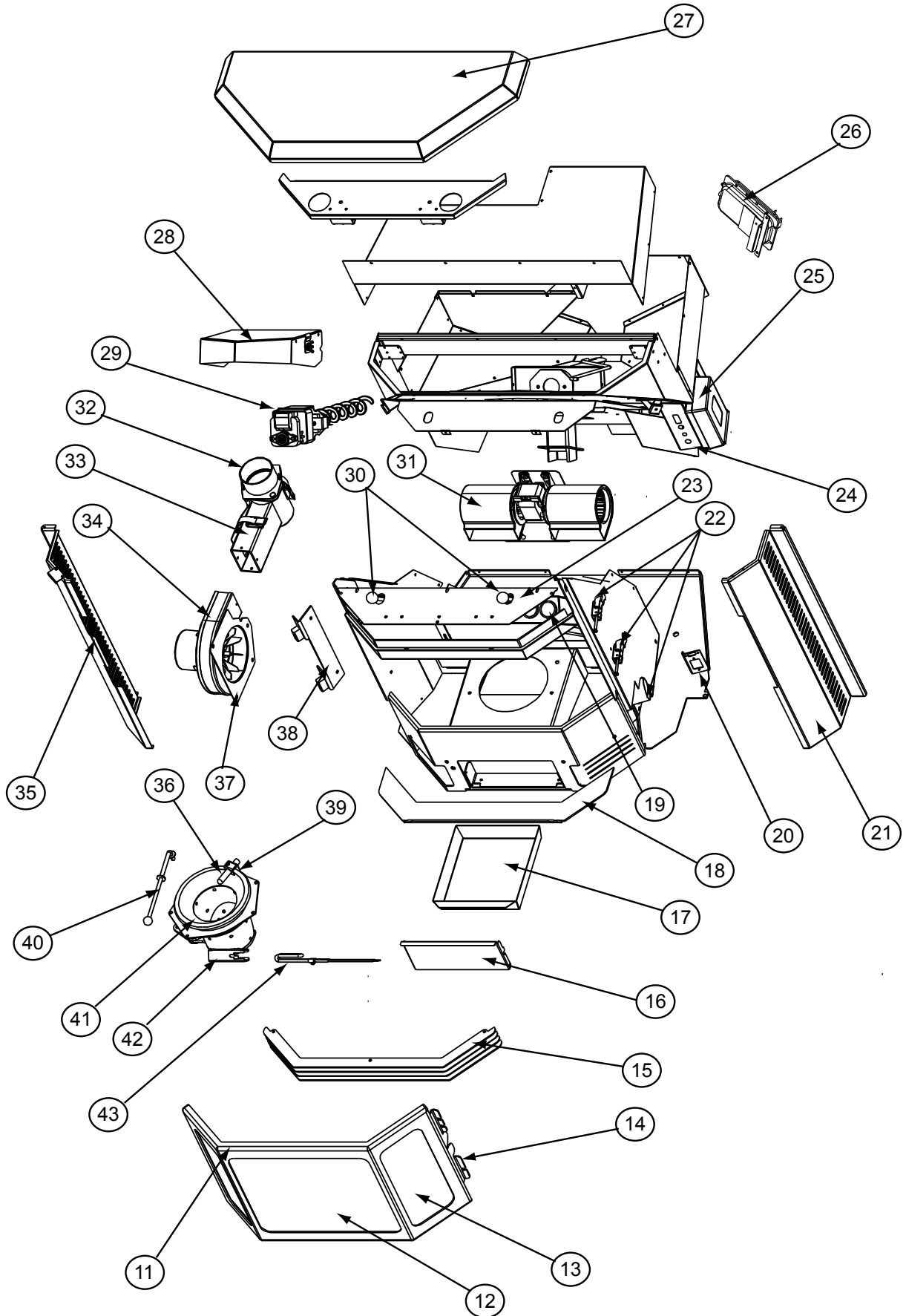

Figure 38.1

D. Service Parts and Accessories

IMPORTANT: This is dated information. The most current information is located on the quadra-fire web site at www.Quadrafire.Com. When ordering, supply serial and model numbers to ensure correct part.

SCHEMATIC LIST

Nbr	Description
11	Door Frame (Black, Gold or Nickel)
12	Glass, Center
13	Glass, Side
14	Door Latch
15	Grille, Louver, Top (Black, Gold or Nickel)
16	Ashpan Door (Panel, Front Access)
17	Ashpan
18	Ash Catcher (Ash Lip)
19	Heat Exchanger Tubes
20	Power Outlet & Thermostat Block
21	Curtain, Side, Right
22	Latch, Draw (3)
23	Heat Shield Extension, Top
24	Junction Box
25	Control Box
26	Vacuum Switch
27	Hopper, Top

Nbr	Description
28	Feed Motor Cover
29	Feed Motor & Spring Assembly
30	Heat Exchanger Cleaning Rods
31	Blower, Convection
32	Exhaust Adapter Assembly
33	Exhaust Transition Assembly
34	Blower, Exhaust
35	Curtain, Side, Left
36	Thermocouple Cover
37	Gasket, Blower, Exhaust
38	Mount, Door Hinget
39	Thermocouple Holder
40	Firepot Pull Rod Assembly
41	Firepot, EZ Clean
42	Igniter Bracket
43	Igniter (Heating Element)

SERVICE PARTS

Item #	Part Description, Alphabetical Order	SKU
18	Ash Catcher (Ash Lip)	410-7830
17	Ash Pan	812-4130
16	Ash Pan Door (Panel, Access Front)	410-7900
	Baffle, Left	812-4200
	Baffle, Right	812-4210
31	Blower, Convection	812-4900
34	Blower, Exhaust	812-3381
	Component Pack (Includes firepot scrapper, touch-up paint, power cord & wiring harness to the thermostat and manual, owner's manual, label "Caution Fireplace Altered" warranty card, consumer's view card and "How-To-Operate" DVD)	812-4330
26	Control Box	SRV7000-205
28	Cover, Feed Motor, Top	410-7920
35	Curtain, Side, Left	812-4310
21	Curtain, Side, Right	812-4320
14	Door Latch Bracket	410-4912
	Exhaust Plenum Clean-Out Plate	410-7910
32	Exhaust Adapter Assembly	510-5330
33	Exhaust Transition Assembly	510-5340
	Feed Motor	812-4421
29	Feed Motor Capacitor Jumper	230-2150

Item #	Part Description, Alphabetical Order	SKU
	Feed Spring Only	812-3600
	Firepot Bolt, 1-1/4" long	225-0120
	Firepot Floor (Slide Plate)	414-0290
	Firepot Nut, 1/4-20	226-0090
40	Firepot Pull Rod Assembly (Linkage)	812-4140
41	Firepot, EZ Clean	812-3351
	Fuse .7 amp, Junction Box	812-0380
	Gasket (Rope), Door	842-2350
	Gasket, 1200 ft per roll, 3/8"	240-0880
	Gasket, 500 ft per roll, 1/2"	240-0940
37	Gasket, Blower, Exhaust	240-0812
	Gasket, Exhaust Blower (Round White) between blower & housing	812-4710
	Gasket, Firepot	510-0530
	Gasket, Flue Flange	240-0850
	Gasket, Tadpole, 10 ft	842-5130
12	Glass Assembly, Center	510-5400
13	Glass Assembly, Side, 1 pc	510-5410
	Grille, Bar Bottom	410-8330
23	Heat Shield Extension, Top	410-7860
	Hinge, Hopper Lid	200-2200
27	Hopper Top	410-7960
	Igniter Wire (5 ft) & 4 Ceramic Nuts	812-4520
43	Igniter, Loop (Heating Element)	7000-226
24	Junction Box & Wire Harness	SRV7000-155
	Knob, Firepot Pull Rod	200-0831
22	Latch, Draw	229-0640
	Latch, Magnet	229-0631
38	Mount, Door Hinge	410-7290
	Mount, Feed Motor	410-7172
	Mount, Hopper Lid Support, Left	410-8200
	Mount, Hopper Lid Support, Right	410-7410
	Mount, hopper Lid Support, Top	410-7560
	Outside Air Collar Assembly	7001-045
	Outside Air Termination Cap	7001-044
	Power Cord	812-1180
	Snap Disc, #1, Convection Blower, 125 degree	230-0470
	Snap Disc, #2, 200 degree	230-0900
	Snap Disc, #3, Manual Reset, 250 degree	230-1290
	Thermocouple	812-0210
42	Thermocouple Bracket	Not Replaceable
36	Thermocouple Cover	812-1322
	Thermocouple Holder	812-3171
	Thumb Screw	7000-223
26	Vacuum Switch	7000-166

Item No.	Accessories	Part No.
	Door Assembly, Black	DR-CB12-MBK
	Door Assembly, Gold	DR-CB12-GD
	Door Assembly, Nickle	DR-CB12-NL
	Floor Protector	811-0730
	Grille, Louver, Black	LVGRL-CB12-MBK
	Grille, Louver, Gold	LVGRL-CB12-GD
	Grille, Louver, Nickel	LVGRL-CB12-NL
	Log Set, 3 pieces	811-0592
	Outside Air Kit	811-0700
	Panel & Trim Set, Small, 30" h x 40" w, Gold	SP-CB12I3040-GD
	Panel & Trim Set, Small, 30" h x 40" w, Nickel	SP-CB12I3040-NL
	Panel & Trim Set, Large, 33" h x 50" w, Gold	SP-CB12I3350-GD
	Rear Shroud Kit	811-0680
	Rear Top Vent Kit	811-0690
	Top Vent Kit, Rear Shroud	811-0650
	Top Vent Adapter, 3 inch	811-0660
	Top Vent Adapter, 4 inch	811-0670
	Thermostat, Mechanical	812-3760
	Thermostat, Programmable #9600	811-0520
	Vent Adapter, 3 inch to 4 inch	811-0720
	Zero Clearance Adjustable Trim Support, 2 inch to 10 inch	841-1000

Appliance	Part No.
CB1200-I Insert, No Door or Grille (order door & grille separately)	CB1200I-B

F. Warranty Policy



Lifetime Warranty

LIMITED LIFETIME WARRANTY

The Hearth & Home Technologies limited Lifetime Warranty guarantees that the following components will work as designed for the lifetime of the stove or Hearth & Home Technologies will repair or replace them. These items include but are not limited to steel and cast iron components, all gas burners, gas logs, combustion chambers, heat exchanger systems, stainless steel firebox components, plating, doors, glass damaged by thermal breakage, steel baffle supports, steel and ceramic baffles and manifold tubes. Labor is for the first five years.

THREE YEAR WARRANTY

Our pellet firepots are covered under Hearth & Home Technologies three-year warranty program. Labor is for 3 years.

TWO YEAR WARRANTY

All electrical components such as but not limited to blowers, wiring, vacuum switches, speed controls, control boxes, thermodisc switches, pilot assembly, gas valves, thermostats and remotes are covered under Hearth & Home Technologies two-year warranty program. Effective April, 2005 igniters are also covered under the two year warranty. Labor is for two years.

ONE YEAR WARRANTY

Porcelain and Powder Coat finishes are warranted against manufacturer defects for one year. Labor to repair or replace these parts is covered for one year, reimbursed per our warranty service fee schedule.

CONDITIONS

This warranty is non-transferable and is made to the original retail purchaser only provided that the purchase was made through an authorized dealer of Hearth & Home Technologies. It must be installed and operated at all times in accordance with the Installation and Operating Instructions furnished with this product, as well as any applicable local and national codes. Any alteration, willful abuse, accident, or misuse of the product shall nullify this warranty.

Labor to repair or replace items covered under the limited Lifetime Warranty will be covered for the first five years per our warranty service fee reimbursement schedule. Parts covered under the limited Lifetime Warranty will be covered for the lifetime of the appliance up to a maximum of ten (10) years after Hearth & Home Technologies discontinues the model and two (2) years for optional accessories. Adjustments, regular maintenance, cleaning and temporary repairs do not qualify for a service call fee and will not be covered. The replacement of consumer replaceable items and installation of upgraded component parts do not qualify for a service call fee, and will not be covered.

This limited Lifetime Warranty does not extend to or include surface finish on the appliance, door gasketing, glass gasketing, glass, firebrick, pellet logs, kaowool or other ceramic insulating materials. It does not cover installation or operational-related problems such as overfiring, use of corrosive driftwood, downdrafts or spillage caused by environmental conditions, nearby trees, buildings, hilltops, mountains, inadequate venting or ventilation, excessive offsets, or negative air pressures caused by mechanical systems such as furnaces, fans, clothes dryers, etc.

Any installation, construction, transportation, or other related costs or expenses arising from defective part(s), repair, replacement, etc., will not be covered by this warranty, nor will Hearth & Home Technologies assume responsibility for them. Further, Hearth & Home Technologies will not be responsible for any incidental, indirect, or consequential damages, except as results in damage to the interior or exterior of the building in which this appliance is installed. This limited Lifetime Warranty does not apply to the venting components, hearth components or other accessories used in conjunction with the installation of this product not manufactured by Hearth & Home Technologies

This warranty is void if the stove has been overfired or operated in atmospheres contaminated by chlorine, fluorine, or other damaging chemicals, the stove is subjected to prolonged periods of dampness or condensation, or there is any damage to the stove or other components due to water or weather damage which is the result of, but not limited to, improper chimney or venting installation. Hearth & Home Technologies may, at its discretion, fully discharge all obligations with respect to this warranty by either repairing or replacing the unit, or refunding the wholesale price of the defective part(s).

This limited Lifetime Warranty is effective on all appliances sold after May 1, 2002 and supersedes any and all warranties currently in existence.

Policy 250-8620 Rev K

QUADRA-FIRE®

CONTACT INFORMATION:

Hearth & Home Technologies
1445 North Highway
Colville, WA 99114
Division of HNI INDUSTRIES
www.quadrafire.com

Please contact your Quadra-Fire dealer with any questions or concerns.
For the number of your nearest Quadra-Fire dealer
please call 1-800-926-4356

	CAUTION
	<p>Do NOT discard this manual.</p> <ul style="list-style-type: none">• Important operating and maintenance instructions included.• Read, understand and follow these instructions for safe installation and operation.• Leave this manual with party responsible for use and operation.



	Your Records for Model:	
	CB1200-I Pellet Insert	
	SERIAL NUMBER:	WHERE PURCHASED:
	_____	_____
	DATE PURCHASED:	_____
	_____	_____
	DATE INSTALLED:	_____
	_____	TELEPHONE: _____

This product may be covered by one or more of the following patents: (United States) 4593510, 4686807, 4766876, 4793322, 4811534, 5000162, 5016609, 5076254, 5113843, 5191877, 5218953, 5263471, 5328356, 5341794, 5347983, 5429495, 5452708, 5542407, 5601073, 5613487, 5647340, 5688568, 5762062, 5775408, 5890485, 5931661, 5941237, 5947112, 5996575, 6006743, 6019099, 6048195, 6053165, 6145502, 6170481, 6237588, 6296474, 6374822, 6413079, 6439226, 6484712, 6543698, 6550687, 6601579, 6672860, 6688302B2, 6715724B2, 6729551, 6736133, 6748940, 6748942, 6769426, 6774802, 6796302, 6840261, 6848441, 6863064, 6866205, 6869278, 6875012, 6880275, 6908039, 6919884, D320652, D445174, D462436; (Canada) 1297749, 2195264, 2225408, 2313972; (Australia) 780250, 780403, 1418504 or other U.S. and foreign patents pending.

