



Card Reader Controller

CRC, CRCXM



Overview

The Card Reader Controller (CRC) provides the power and electronics required to monitor and control a single door with both entry and exit readers. The unit is designed to mount in close proximity to the door it controls, however it can be located remotely from the readers in retrofit applications. The unit is housed in an off-white Cycloy® housing. Its attractive design allows for surface mounting in exposed areas.

All access decisions are made locally in the CRC. The CRC's non-volatile memory can hold schedules and holiday information for up to 8,000 cardholders. The CRCXM has additional memory, and supports 36,000 cardholders. The memory also retains the last 5,000/20,000 events for logging purposes. This history information is uploaded at the request of the access control database for use in a variety of reports.

The unit provides 12 Vdc @ ½ amp for door strike or magnetic lock requirements. An integral standby battery can provide up to four hours of service for applications that use electric door strikes. An integral tamper switch is also provided.

Two input circuits are provided for security devices. These are typically used to monitor door position and request to exit devices. Input circuits can also be configured as a "buzz in" switch to manually unlock the door, or as security input points when used with Synergy-enabled EST3.

A handicapped feature output is provided to operate mechanical door openers with extended door-open times. This output is activated when a cardholder with the disabled option activated presents their card to the reader, helping provide barrier-free access.

Standard Features

- Listed for fire, security, and access control
- Support of Wiegand output devices — Proximity, Mag Stripe, etc.
- Total support for one door
- Two supervised device circuits
- Integral standby battery (optional)
- Supports maglock and strike operation
- PIN pad support and schedule
- Memory for 8,000/36,000 cardholders
- Self-contained operation
- Maintains all schedules and holidays
- No degraded mode needed
- Aesthetically pleasing design
- Integrates with EST3 and ACDB-KE systems
- Can initiate system activity
- Can respond to system activity
- Handicapped option facilitates barrier-free operation
- Construction card
- Optional sounder
- Can use existing cards and readers

Application

Card Reader Controllers support Synergy-enabled EST3 control platforms under EST's Access Control Database (refer to Data Sheet 85010-0098), and ACDB-KE standalone keyless entry systems under the ACDB-KE software program (refer to Data Sheet 85010-0132).

Credential Reader Support

The CRC(XM) is compatible with most credential readers such as proximity and biometric devices having a standard Wiegand output. Each CRC is capable of controlling both the ingress and egress readers for a single door. Multiple readers for ingress and egress are supported simply by paralleling the readers. This can allow the use of multiple card types at a single door.

CRCs provide support for a Construction Card. This feature facilitates system testing and an extra level of security until a database is downloaded into the CRC. Once the CRC has a cardholder database downloaded into it, the construction card automatically becomes deactivated.

The CRC provides LED drivers to visually indicate whether access is granted or denied. These generate different LED flash rates when PIN numbers or a second card (two-man rule/escorted visitor) is required. A driver for an audible sounder is also provided by the CRC.

Access Levels, Schedules, and Holidays

An access level is a name assigned to a group of cardholders that share common access privileges. These privileges consist of a list of doors, each with a specified schedule. Any combination of doors can be assigned to an access level. The CRC(XM) supports 1,200 different access levels (up to 255 per tenant, up to 255 per ACDB-KE system), and each cardholder can belong to two access levels at the same time.

The CRC maintains in its memory all access levels, schedules and holidays, created by the Access Control Database Program. Each schedule identifies the specific time(s) (in 15-minute increments) and day(s) during which specific cardholders are permitted through a given door. The CRC(XM) can store up to 1,200 schedules (up to 255 per tenant) and 1,200 holidays (up to 255 per tenant).

Holidays are exceptions to normal Monday through Sunday schedules, when different access requirements are desired. Many holidays can be programmed using rules rather than fixed dates. This minimizes year-to-year programming required to update holidays annually. Fixed holidays, such as January 1st, that fall on a Saturday or Sunday can automatically be scheduled for the closest Monday or Friday to coincide with statutory holidays.

Note: Not all CRC features described are supported by all compatible software. Please refer to the software catalog sheets and manuals to determine functionality.

Synergy-Enabled Application

True integration permits system functions to interact seamlessly, such as unlocking exit doors during a fire. A simple program rule unlocks doors, replacing additional conduit, wiring and interposing relays. Want to disarm security partitions automatically when an authorized cardholder enters the building? Integration and another system rule easily provides a solution.

Because each CRC makes its own access decisions, very little network traffic is generated by the access control function. This, along with the integrated design of the network operating system ensures that fire signals always receive the highest priority. To reduce traffic even further, the CRC can be configured to report only

denied or irregular events.

There is no degradation in system performance when both fire and security devices are installed on the same network. The CRC(XM) uses the same high quality components used in our fire devices, and is UL-listed to fire (UL-864/ULC-S527), card access (UL-294) and burglary (UL-609/ULC-S303) standards.

The Card Reader Controllers and Keypad Displays (KPDISP*) are connected to the system over a supervised, dedicated RS-485 connection to the Security Access Control Module (3-SAC). Each 3-SAC can support up to 62 CRCs or KPDISPs. This is a multi-drop circuit and does not require a home run for each device. Should network communications be lost, the CRC will continue to grant access based on the complete database stored in its memory, without loss of any security feature, except possibly anti-passback, two-man rule, and muster operations. For these type of applications a Class A/Style 6 configuration can be installed. In Class A the maximum number of devices on the 3-SAC is 30, providing continued uninterrupted operation in the event of most wiring faults.

Database Management

Each CRC(XM) contains the entire access control database within its memory. This distribution of intelligence minimizes traffic on the network, maximizing access decision speeds. Cardholder data is created and stored in the Access Control Database (ACDB) or ACDB-KE software program that runs on any PC (see the ACDB catalog sheet or ACDB-KE catalog sheet). This information is then encrypted and sent to the CRCs by a hardwire or dial-up connection.

In a network environment, the PC is simply equipped with a conventional modem. The ACDB program then dials up the network and sends the encrypted database information via the network to the individual CRCs. This allows a ACDB to serve multiple sites. Dial-up data entry also permits multiple tenants to share a common access control system without sharing a common database. PCs may also be directly connected to the system using a direct serial connection.

** See KPDISP literature for a full description of the functionality offered by the keypad display*

Networked Applications

Access controlled doors can be grouped into one of 255 partitions. Partitions are used to define the protection for a given area. This facilitates arming and disarming of security alarms, as well as anti-passback, two-man rule, and muster operation. Each CRC can support one partition.

As part of an integrated system, CRCs can be programmed to automatically bypass alarm points, eliminating one of the most common causes of false alarms. Integration also permits the system to be programmed to automate routine functions such as turning on lights and adjusting room temperature.

Up to 255 tenants are supported by the CRC. During system installation, the available schedules and holidays are allocated to each one. The use of individual access control database programs and dial-up modem connections simplifies the addition of a new tenants or the reconfiguring of existing ones.

Doors located at remote sites are supported using dial-up modem connections. No local dedicated PC or computer wiring is required for database transactions.

Elevator floor access control is accomplished using the CRC and the EST3 integrated system. Because the fire portion of the system is already interconnected with the elevator controller for elevator capture functions, floor access control is a simple extension of this pre-existing function.

The CRC(XM) is listed to UL-864, the fire alarm standard, to UL-294, the access control system unit standard, and to UL-609/ULC-S303 burglar alarm standards. This raises the level of the access control components up to the high standards of fire alarm equipment and permits fire, security, and access control functions to be fully integrated while assuring all listing and code requirements are met.

The CRC's flexibility supports three different versions of anti-passback: strict, timed, and logged. Strict anti-passback requires the use of an exit reader and will not permit reuse of a card until it has been used to exit the area. In order to eliminate the need for an exit reader, the timed anti-passback mode prohibits the reuse of the card for a predetermined time period. This virtually eliminates users passing a card back to a second user, this is the origin of the anti-passback feature. The logged anti-passback mode permits access, but logs any violation to history for future employee counselling.

When an area is served by more than one door, a networked system is required to provide support for two-man rule operation, muster operation, and strict anti-passback. The network coordinates user information between CRCs that serve a common area.

ACDB-KE Keyless Entry Applications

The CRC provides effective support for standalone applications in conjunction with EST's ACDB-KE keyless entry software package. ACDB-KE can accommodate up to 31 doors. It offers many of the standard access control features found in the ACDB including cardholder-specific access privileges, multiple access levels, customizable schedules, and holiday rules.

ACDB-KE offers no security functions. However, CRC Form-C relays can be configured to trigger external door openers, or they can be programmed to interface with third-party security systems. To achieve security functionality, the relay can be set to change state if no REX, valid card read, or unlock timer is in effect when the door is opened. When connected to a security system, this allows the use of the door position contact as a security input.

ACDB-KE communicates with the CRC via hard-wired RS-232 to RS485 converters.

Database Management

ACDB-KE standalone keyless entry systems communicate with CRCs via hardwired RS-232 to RS-485 converters.

Engineering Specification

Synergy Enabled Applications

The Card Reader Controller (CRC) shall provide the power and electronics required to monitor and control a single door, both entry and exit readers; all necessary support for request to exit devices, automatic door openers, and locking mechanisms. All access decisions shall be made by the CRC. Decisions made by a centralized controller shall not be considered as equal. Each CRC shall maintain all schedules and holiday schedules for up to <8,000><36,000> cardholders. Upon loss of communication with the security/access control module, the CRC default mode shall provide 100% functionality utilizing all schedules and holiday data stored in its memory, and shall not grant access solely by matching facility codes. Each controller shall retain <5,000><20,000> history events in its memory. History events shall be uploaded to the access control database program under manual and/or automatic control.

The CRC shall be capable of connecting to any credential reader that

uses the standard Wiegand output protocol format, and shall support PIN# input through a keypad (using 8-bit Dorado format) that is integral to the reader. It shall be possible to program a PIN schedule such that a PIN number is only required at specific times (eg. weekends and evenings) to gain access and <is><is not> required during regular business hours. The controller shall provide two configurable supervised input circuits for use as request to exit devices, security inputs, or manual "buzz in" control. The controller shall provide a set of form "C" relay contacts to activate an automatic door opener when a valid card with the handicapped option enabled is presented to the reader. Other relay functions shall be programmable

The CRC shall be housed in an attractive enclosure suitable for surface mounting near the door without detracting from interior aesthetics. Power for the CRC shall be <16VAC provided by a local class 2 plug-in transformer> <24 VDC supplied by the integrated network> <The controller shall be equipped with a standby battery and integral charger, to minimize the effects of a loss of power. The battery shall be capable of operating a lock strike for up to four hours.> The controller shall provide 12 VDC @ ½ amp to operate the door locking mechanism. The lock control voltage shall be configurable as either energize to access or de-energize to access.

As a multi-function component of a truly integrated system, the card reader controller shall be listed according to Underwriter's Laboratory Standards: <UL-294 Access Control System Units, UL-864 Control Units for Fire-Protective Signaling Systems, and UL-1610 Central-Station Burglar-Alarm Units><ULC-S527, UL-294, ULC-S301>. Controllers not having all of the specified agency listings will not be considered as equal.

The card reader controller shall be a Edwards model <CRC (8,000 cardholder)><CRCXM (36,000cardholder)>.

ACDB-KE Applications

The Card Reader Controller (CRC) shall provide the power and electronics required to monitor and control a single door, both entry and exit readers; all necessary support for request to exit devices, automatic door openers, and locking mechanisms. All access decisions shall be made by the CRC. Each CRC shall maintain all schedules and holiday schedules for up to 8,000 cardholders.

The CRC shall be capable of connecting to any credential reader that uses the standard Wiegand output protocol format, and shall support PIN# input through a keypad (using 8-bit Dorado format) that is integral to the reader. It shall be possible to program a PIN schedule such that a PIN number is only required at specific times (eg. weekends and evenings) to gain access and <is><is not> required during regular business hours. The controller shall provide two configurable supervised input circuits for use as request to exit devices, security inputs, or manual "buzz in" control. The controller shall provide a set of form "C" relay contacts to activate an automatic door opener when a valid card with the handicapped option enabled is presented to the reader. Other functions shall be programmable

The CRC shall be housed in an attractive enclosure suitable for surface mounting near the door without detracting from interior aesthetics. Power for the CRC shall be <16VAC provided by a local class 2 plug-in transformer> <24 VDC supplied by the listed power supply> <The controller shall be equipped with a standby battery and integral charger, to minimize the effects of a loss of power. The battery shall be capable of operating a lock strike for up to four hours.> The controller shall provide 12 VDC @ ½ amp to operate the door locking mechanism. The lock control voltage shall be configurable as either energize to access or de-energize to access.

The card reader controller shall be a Edwards model CRC.

Typical Wiring

Synergy Enabled Applications

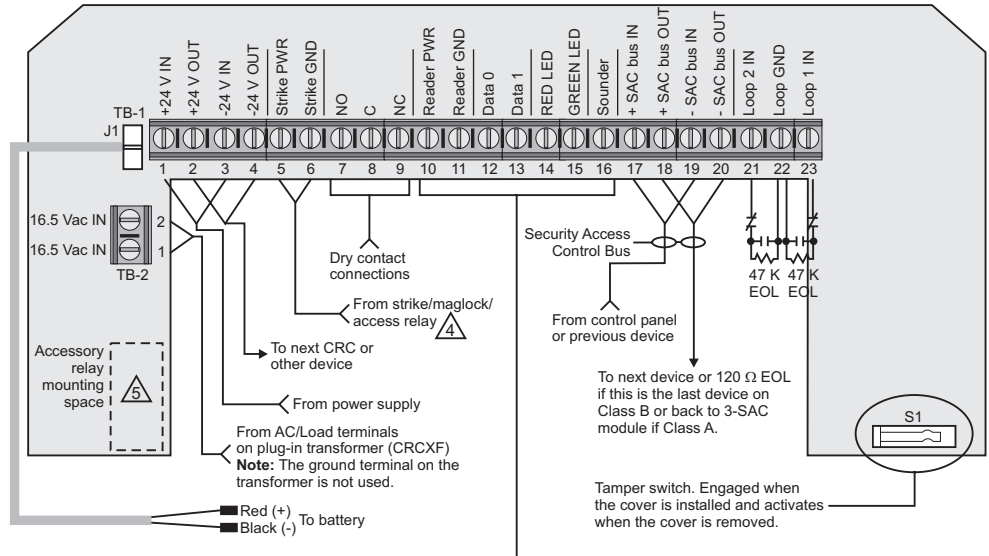
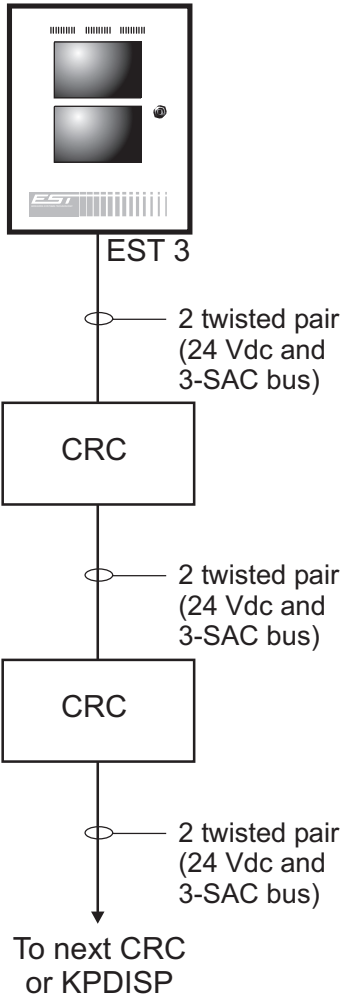

Reader manufacturers	CRC terminal block numbers (designators)						
	10 (Reader power)	11 (Reader GND)	12 (Data 0)	13 (Data 1)	14 RED LED	15 GREEN LED	16 (Sounder)
EST / HID (3)	Red	Black	Green	White	Brown	Orange	Yellow
Motorola Indala (3)	Red	Black	Green	White	Brown	---	Blue
Dorado	Red	Black	Green	White	Brown	---	Yellow
Sensor Eng.	Red	Black	Green	White	Violet	Brown	Blue
Keri	Red	Black	Green	White	Brown	Orange	Blue
Radio Key (3)	Red	Black	Green	White	Brown	Orange	Blue
Paradox/Position Technology	Red	Black	Green	White	Orange	Yellow	Brown

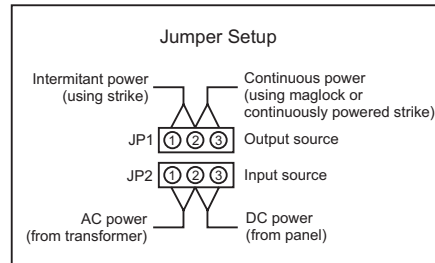

Notes:

- ⚠ If used as an inside reader, connect the green wire to TB1-13 and the white wire to TB1-12.
- ⚠ Connect wiring only when using the reader's sounder.
- ⚠ Program for dual-LED control.
- ⚠ Use a 4.7 KΩ, 1/4 watt resistor if no strike is being used to maintain supervision.
- ⚠ When maglock or door strike voltage or current is outside CRC(XM) operational parameters, use an accessory relay (catalog number CRCRL) and a listed external power supply to power the lock. Refer to the accessory relay's installation sheet (3100294) for more information.
- ⚠ Minus common from control panel must be maintained

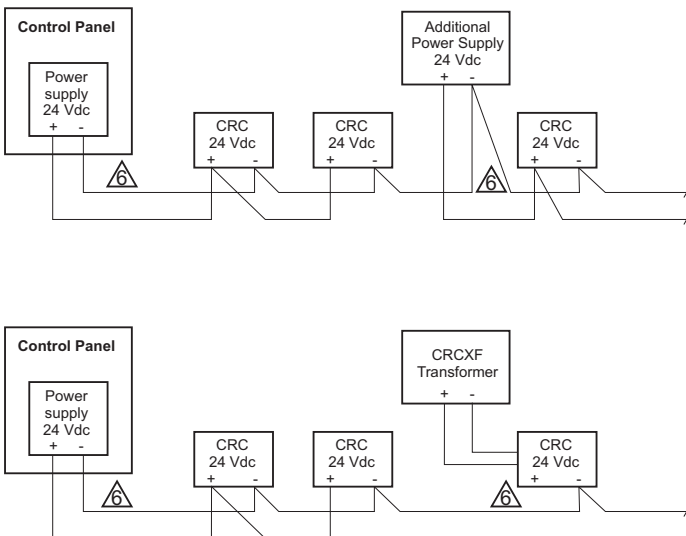

Typical Wiring

ACDB-KE Applications

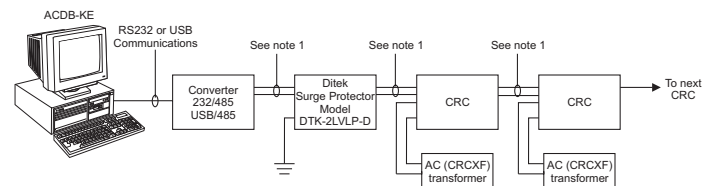

Note 1: Three wires = 1 common, 1 twisted pair RS-485 with 6 twists per ft. min. See literature sheet 85010-0132 for additional ACDB-KE drawings

Specifications

Agency Listings	UL, ULC (See Note 1)
Door Capacity	Each CRC(XM) serves one door - one ingress reader/keypad, one egress reader/keypad, one lock mechanism, and required request to exit devices.
Credential Reader Compatibility	Any Wiegand output device including proximity, magnetic stripe, Wiegand, Barium Ferrite, & biometric readers with Wiegand outputs.
Keypad Compatibility	Any reader with integral keypad using the Dorado® 8-bit keypad format.
Input Circuits	Two supervised. Configurable for request to exit button/PIR motion detector, security input, or “buzz in” switch.
Lock Control	Network programmable bypass, arm/disarm
Power	12 Vdc @ 0.5A, max
Lock Types supported	Configurable for continuous (mag-lock) or pulse (strike) operation
Supervision	Strikes are supervised for presence
Delay	Programmable exit delay
Reader Power	12 Vdc @ 0.5A, max.
Cardholder Capacity	CRC = 8,000; CRCXM = 36,000
Schedules & Holidays	1,200 schedules and 1,200 holidays. Each tenant in an integrated system, or each ACDB-KE system, can be assigned up to 255 schedules and 255 holidays.
Anti-Passback	Networked = 62 doors per partition on the same 3-SAC
2-Man Rule	Networked = 62 doors per partition on the same 3-SAC
Partitions	Networked = 255
Muster operation	61 doors per partition on the same 3-SAC
Event Memory	CRC = 5,000 events, CRCXM = 20,000 events; configurable for all, denied, or irregular events
Network Communications	RS-485, Class A or Class B 4,000ft (1,220m) maximum circuit length (3-SAC)
Keyless Entry Communications	RS-232 to RS-485: Use B&B Electronics Model 485CSP2 or equivalent (Note: Port powered RS-232 to 485 converters are not recommended. Always use converters with external power supplies.)
ACDB-KE computer to CRCs	USB to RS-485: Use B&B Electronics Model USTL4 or equivalent TCP/IP to RS-485: Use Edwards NETCOM-1S
Local Sounder (CRCSND)	Optional piezo sounder configurable for door ajar and unauthorized entry/exit - 12 Vdc @ 7mA
Form C Relay	Contact (30 Vdc/ac @ 2A, resistive) to operate system auxiliary functions including automatic door openers
Supervision	
Input Circuits	Class B monitored for opens, shorts & normal conditions
Tamper	Cover monitored for normal & open conditions
AC Fail	Monitored for loss of AC power
Low Battery	Monitored for low battery voltage during primary power loss
Strike	Monitored for open & normal conditions when door is locked
Reader	Monitored for open and normal conditions
CPU/Memory	Monitored for internal failures, erase or write failures
Network Communications	Monitored by the network
Internal Clock	24 hour clock. Automatically synchronized on networks
Power Requirements from 24 Vdc source	310 mA + (Lock current @ 12 Vdc) + (Reader Current @ 12 Vdc) + (CRCSND current, if used).
CRC(XM) Transformer Powered	Max. AC power will not exceed 40 VA @ 120 Vac
Wire Size	14 to 22 AWG (1.5 mm ² to 0.25mm ²) See Note 2.
Standby Battery (optional)	12V @1.2AH (approximately 4 hours standby w/strike - standby time may vary depending on door traffic)
Operating Environment	0°C to 49° Complete (32°F to 120°F) @ 93%RH, Non-condensing
Housing	Off-white Cyclocoly® Thermoplastic
Dimensions (HWD)	4.75" x 8.0" x 2.5" (12.0cm x 20.5cm x 6.4cm)
Mounting	Surface mount. Optional 4" square or 2-gang or 100mm ² electrical box

Note 1:

The EST3 is modularly listed under the following standards:

UL 864 categories: UOJZ, UOXX, UUKL and SYZV, UL 294 category ALVY, UL 609 category AOTX, UL 636 category ANET, UL 1076 category APOU, UL 365 category APAW, UL 1610 category AMCX, UL 1635 category AMCX ULC-S527, ULC-S301, ULC-S302, ULC-S303, ULC-S306, ULC/ORD-C1076, ULC/ORD-C693. Please refer to EST3 Installation and Service Manual for complete system requirements.

Note 2:

When wiring between CRCs is installed outside as between two buildings, surge protection is needed on the CRC wires leaving and entering the building. Use Ditek's Surge Protector Model 2LVLP.



Detection & alarm since 1872

U.S.
T 888-378-2329
F 866-503-3996

Canada
Chubb Edwards
T 519 376 2430
F 519 376 7258

Southeast Asia
T : +65 6391 9300
F : +65 6391 9306

India
T : +91 80 4344 2000
F : +91 80 4344 2050

Australia
T +61 3 9239 1200
F +61 3 9239 1299

Europe
T +32 2 725 11 20
F +32 2 721 86 13

Latin America
T 305 593 4301
F 305 593 4300

utcfireandsecurity.com

© 2010 UTC Fire & Security.
All rights reserved.

Ordering Information

Catalog Number	Description	Shipping Wt., lb (kg)
CRC	Card Access Controller w/memory for 8,000 cardholders	1.5 (0.68)
CRCXM	Card Access Controller w/memory for 36,000 cardholders	1.5 (0.68)
CRCSDND	CRC Sounder Module	0.25 (0.11)
12V1A2	12V @1.2AH Standby Battery	1.75 (0.79)
CRCXF	Class 2, 120 Vac Input/16 Vac Output. Plug in Transformer 40VA	2.0 (0.91)
CRCRL	Access Control Accessory Relay 12 Vdc 34mA coil, N/O contact, rated at 2 amps @ 30 Vdc .6PF, 2 amps @ 120/250 Vac .6PF.	0.25 (0.11)