



**Magnafire Mark I**  
**Magnafire Mark II**  
**Magnafire Mark III**

**Caution:**

Read Warnings and Safety  
Considerations/Recommendations  
For Safe Installation & Operation.  
Please "Read Carefully."

**Installation  
and  
Operator's  
Manual**

*"Built To A Standard Not A Price"*

# **Thank You . . .**

THANK YOU FOR PURCHASING A HARMAN STOVE AND FOR READING THIS OWNER'S MANUAL. It is our desire to provide as much data as needed to allow you to install and operate your Harman Stove in the safest manner possible.

If you have any questions regarding your Harman Stove which were not covered in this manual, contact your local dealer or factory direct.

\*\*\*\*\*

## **Safety Notice:**

IF THIS STOVE IS NOT PROPERLY INSTALLED, A HOUSE FIRE MAY RESULT. FOR YOUR SAFETY, FOLLOW INSTALLATION DIRECTIONS. CONTACT LOCAL BUILDING OR FIRE OFFICIALS ABOUT RESTRICTIONS AND INSTALLATION INSPECTION REQUIREMENTS IN YOUR AREA.

# Index

## INTRODUCTION

READ ALL INFORMATION "PRIOR" TO PROCEEDING WITH INSTALLATION, AND CHECK WITH YOUR LOCAL AUTHORITIES FOR PREVAILING FIRE ORDINANCES AND RECOMMENDATIONS.

1. **SAFETY CONSIDERATIONS** - Warnings to owner/operator of possible dangers, fire hazards and cautions.
  - 1.1 Keep children away -- may cause serious burns.
  - 1.2 Fuel/Firing Warnings
  - 1.3 Curing Paint
  - 1.4 Mobile Homes
2. **ASSEMBLY**
3. **CHIMNEY** - Proper draft/venting
  - 3.1 Types of Chimneys
  - 3.2 Common Chimney Problems
  - 3.3 What To Do When You Have A Problem
  - 3.4 Chimney Details
4. **ELECTRICAL**
  - 4.1 Electrical Warnings
5. **GRATES**
  - 5.1 Grate System and Controls
6. **INSTALLATION INSTRUCTIONS**
  - 6.1 Unpacking and Inspection of Parts
  - 6.2 Warnings
  - 6.3 Locating the Stove
  - 6.4 General Information
7. **PREVENTIVE MAINTENANCE INSTRUCTIONS**
  - 7.1 Periodic and Normal Everyday
8. **OPERATING INSTRUCTIONS**
  - 8.1 Starting A Coal Fire
  - 8.2 Loading
  - 8.3 Increase Heat From A Low Fire
  - 8.4 Shaking
  - 8.5 Draft Controls
  - 8.6 Ashes
  - 8.7 Safety
9. **WARRANTY**
  - 9.1 Terms - Warranty
10. **WARRANTY ACTIVATION COUPON AND LIABILITY STATEMENT**
11. **OPTIONAL HOT WATER COIL**

# 1. Safety Considerations

## 1.1 KEEP CHILDREN AWAY - MAY CAUSE SERIOUS BURNS

**CAUTION:** ALL SURFACES OF STOVE ARE HOT. DO NOT TOUCH. KEEP CHILDREN AWAY. SERIOUS BURNS WILL RESULT IF TOUCHED. THIS IS A HEAT PRODUCING APPLIANCE. SERIOUS BURNS MAY RESULT IF THE STOVE IS TOUCHED DURING FIRING.

## 1.2 FUEL/FIRING WARNINGS

DANGER! FIRE HAZARD! DO NOT USE CHEMICALS OR FLUIDS TO START OR "FRESHEN UP" A FIRE. SEVERE BODY BURNS OR A FIRE IN YOUR HOME COULD RESULT. DO NOT BURN GARBAGE, GASOLINE, THINNERS, DRAIN OR ENGINE OIL, KEROSENE, OR FUEL OIL, ETC. AN EXPLOSION, A HOUSE FIRE OR PERSONAL INJURY COULD RESULT. KEEP ALL SUCH LIQUIDS WELL AWAY FROM THE STOVE WHILE IN USE.

**This heater is for burning coal only. Use of any other fuel except for coal ignition is a violation of federal law.**

When and if the chimney pipes or connectors reach 500 degrees fahrenheit (maximum temperature), the stove is being over fired. We recommend the purchase of a Harman Magnetic Temperature Gauge to monitor the stove and stack temperatures relative to the amount of draft the customer permits the stove to operate.

It has been verified that creosote will ignite at 650 degrees fahrenheit. It is the owner's responsibility to follow these recommendations.

This stove consumes air when it is burning. It is advisable that a window in the vicinity be opened slightly while stove is burning if your house is tightly sealed and insulated. (Information contained in this manual is manufacturer's recommendations and if there is any difference between our recommendations and local code requirements, we suggest following local code requirements.)

## 1.3 Curing Paint

During the first few hours of burning, a blue smoke will be observed rising from the painted surface of the stove. It is advisable to increase the amount of fresh air in the room during this breaking-in period. This may be achieved by opening doors, windows, etc. Don't be alarmed, this is normal.

## 1.4 Mobile Homes

Harman Stoves are not approved or recommended for mobile homes.

# 2. Assembly

Slide blower into slots as shown. Blower will rest at bottom of slot.

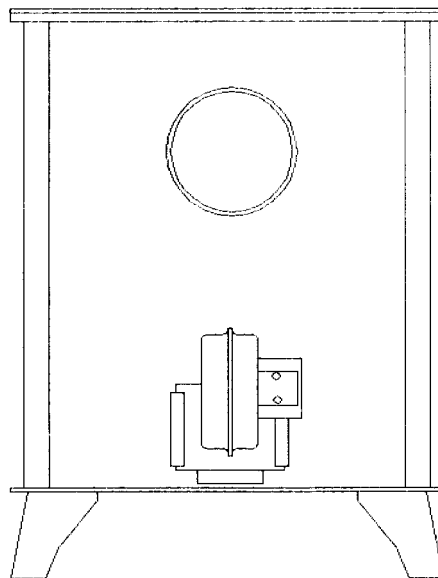

## Firebrick Diagram

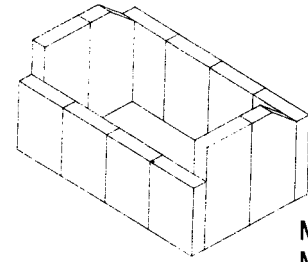

MAGNAFIRE MARK I

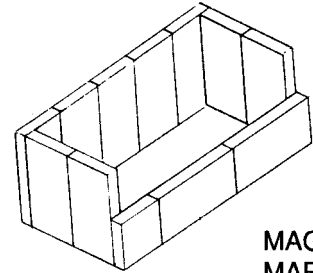

MAGNAFIRE MARK II

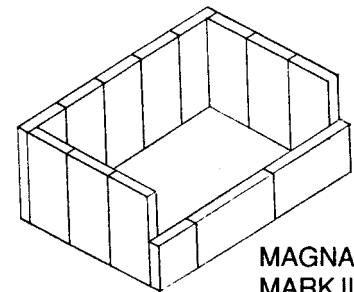

MAGNAFIRE MARK III

# 3. Chimney

## 3.1 Types of Chimneys

The chimney is one of the most important, yet most neglected and misunderstood portion of any solid fuel burning installation. We do not recommend that the stove be connected to a chimney with other heating devices.

THE STOVE MUST BE CONNECTED TO ITS OWN TILE-LINED FLUE. A MINIMUM FLUE SIZE OF 8" X 8" IS NECESSARY FOR PROPER OPERATION AND APPROVED FOR ALL FUELS.

UNDER NO CIRCUMSTANCES SHOULD A MANUAL FLUE DAMPER BE INSTALLED IN THE SMOKE PIPE BETWEEN STOVE AND CHIMNEY!

No damper, heat saver, or automatic vent damper device should be installed in or on the smoke pipe.

NO OTHER APPLIANCES SHOULD BE VENTED TO THIS FLUE!

CAUTION: THE CHIMNEY MUST BE A CLASS "A" CHIMNEY IN GOOD OPERATION CONDITION.

NOTE: THE USE OF ALUMINUM TYPE "B" GAS VENT FOR SOLID FUELS IS UNSAFE AND PROHIBITED BY THE NATIONAL FIRE PROTECTION ASSOCIATION CODE.

There are three types of Class "A" chimneys:

- A. Masonry with tile liner to include brick or stone. It must be supported on grade level foundation.
- B. Insulated Class "A" manufactured chimney, listed or certified by a national test agency.
- C. Triple Wall Metal Class "A" chimney, listed or certified by a national test agency.

If your masonry chimney has not been used for some time, have it inspected by a qualified person (building inspector, fire department personnel, etc.) If a listed or certified manufactured chimney is to be used, make certain it is installed in accordance with the manufacturer's instructions and all local and state codes. See Figure No. 1 of Manufactured Chimney Installation and Figure No. 2 of Masonry Chimney (note roof clearance in accordance with NFPA 211.)

### 3.2 Common Chimney Problems

In order to have a proper operating solid fuel heating system, the chimney must be capable of providing the draft required.

The minimum required draft is .06 inches W.C. (water column). This must be measured using a draft gauge.

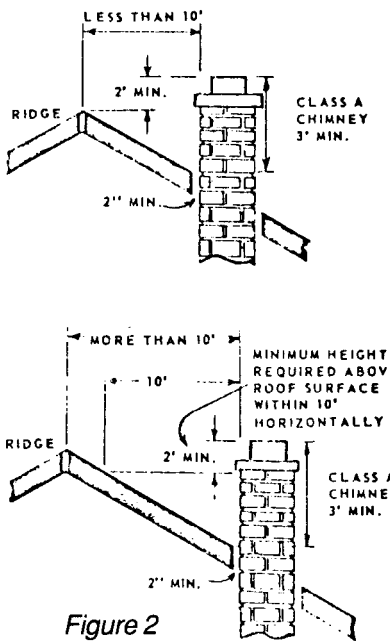
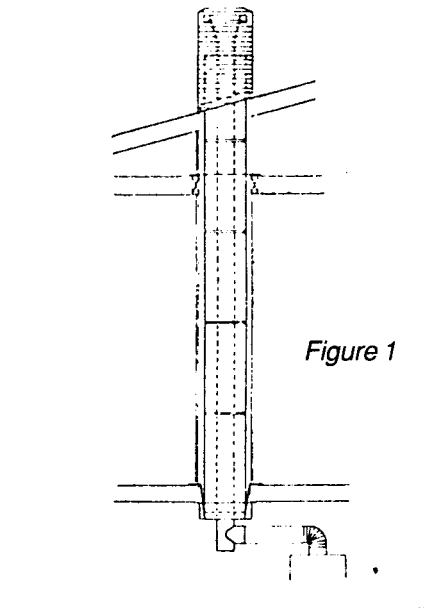

If the chimney cannot supply this constant draft, the unit will not operate properly.

In some installations, a barometric draft regulator may be used and properly adjusted to compensate for excessive draft.

#### **IMPORTANT!**

Whenever you measure the draft, the stove must be operating and sufficient time given for the chimney and stove to warm up. This should take a minimum of thirty minutes.

The draft reading is taken 18" up from the center of the stove flue outlet in the smoke pipe.

REASONS for insufficient draft readings:

- A. Leaky Chimney - Air leaking in around a loose fitting cleanout door, flue pipes not tight at the joints, improper plug openings or defective masonry.
- B. Chimney Improper Height - Chimney does not extend through the roof to a sufficient height to promote sufficient draft or causes a down drafting condition to take place. (See Figure No. 3).
- C. Obstructions in the chimney. Check prior to using by holding a mirror in chimney clean-out door. This will give a view of the chimney.
- D. Trees or Other Topographical Barriers - Impeding the chimneys operation or causing a down draft condition to exist. This can also be caused by adjacent buildings or the roof of the same structure where the chimney is not high enough (See Figure no. 3).

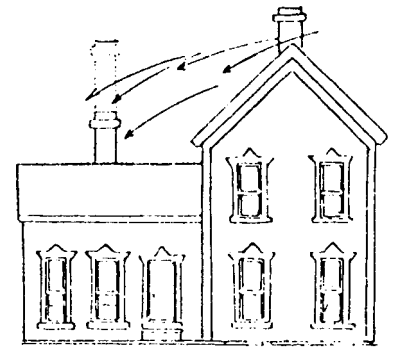

NOTE: The Chimney on the house illustrated is too low. It should be raised to compensate for drafts.

- E. Chimney Size - Chimney is not properly sized to adequately vent the appliance. It is either too small or too large.
- F. Chimney Offsets - Chimneys with offsets should not be used. They cause an obstruction to draft as well as a place for debris to collect.
- G. Elbow Restrictions - The flue pipe is connected to the chimney with too many elbows, reducing the draft the chimney can provide.

H. Multiple Venting - No more than one device shall vent into the same chimney flue.

THE MOST IMPORTANT THING TO REMEMBER ABOUT CHIMNEYS IS THEIR NEED FOR MAINTENANCE AND CLEANING. IF CHIMNEYS ARE NOT CLEANED ON A FREQUENT BASIS. IT WILL AFFECT THE DRAFT, AS WELL AS BEING A CONTRIBUTING CAUSE TO A CHIMNEY FIRE.

### **CAUTION**

ANYTIME YOU HAVE A CHIMNEY FIRE THE FOLLOWING POINTS SHOULD BE OBSERVED:

1. BE SURE EVERYONE IS OUT OF THE HOUSE.
2. CALL THE FIRE DEPARTMENT.
3. CLOSE DOWN DRAFT DAMPER ON STOVE.

AFTER THE FIRE IS EXTINGUISHED, DO NOT USE THE CHIMNEY UNTIL A QUALIFIED PERSON HAS INSPECTED YOUR CHIMNEY.

### **3.3 What To Do When You Have A Problem**

#### **A. Smoke Puffs From Your Stove:**

1. Check the chimney draft. With a good fire burning, the chimney should supply .06" updraft.
2. Check draft controls for proper operation.
3. Check the smoke pipe and be sure it is clean.
4. Chimney may be too low. Increase the height. Make sure the chimney is structurally sound.
5. Add more air to the room. Your home may be so airtight that not enough oxygen is reaching the fire.
6. REMEMBER, open the draft controls and crack the fire door slightly before recharging the fire chamber or checking the fire.

**SPECIAL WARNING: NEVER OPERATE YOUR STOVE WITH THE FIRE OR ASH DOOR OPEN!**

7. Check the smoke pipe and make certain each joint is tight and the connections to the stove and chimney are airtight.

8. Check the ashes. Ashpan and fire compartment may be overloaded with ashes.

9. Check your chimney for down drafts. This is caused by air currents being deflected down the chimney from higher objects, such as trees, buildings and hills. This problem can usually be corrected with an open-vented chimney cap.

10. Make sure the chimney cleanout door is tightly closed and sealed.

11. If other fuel-burning devices are connected to the chimney they may be causing draft problems. This must be corrected by your heating contractor.

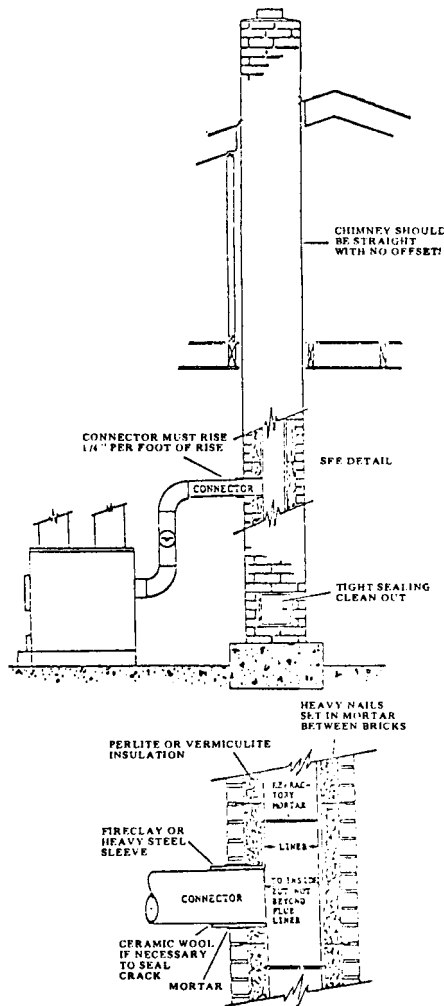

### **3.4 Chimney Details**

Chimney Liners - Most of the customer inquiries received are problems caused by poor, or in some cases, excessive draft. A result of poor draft could be creosote, backpuffing, and smoky firebox when loading. Indications of excessive draft are burning too much fuel and high stack temperatures.

The most common cause of poor draft is an improperly sized flue liner. We recommend that the chimney liner's inside dimensions be at least as large as the appliance's collar size.

TO SUMMARIZE, A HEATING UNIT CAN PERFORM ONLY AS WELL AS ITS VENTING SYSTEM WILL ALLOW IT.

## **4. Electrical**

### **4.1 Warnings**

Turn off electric power at fuse box or circuit breaker panel before making any line voltage connections. Follow local electrical codes. Be sure to route power so that it doesn't come in contact with the stove.

**IMPORTANT!** ALL WIRING SHOULD BE DONE IN ACCORDANCE WITH LOCAL AND STATE CODES.

## **5. Grates**

### **5.1 Grate System and Controls**

A. Heavy-Duty Cast Iron Grate System - The functions of a grate system are to support the coal and at the same time provide air flow through the grates to the coal. Harman grates have a maximum amount of air flow to produce an even burning fire. Another function is to remove the ash from the unburned coal by grinding, breaking or shaking them until the ashes fall through the grates. Harman grates provide a variable amount of grinding action controlled by the movement of a long shaker-lever located on the left side of the stove. Grates are removable without tools.

B. Burns Three Sizes of Anthracite - You can burn pea, nut or stove coal with these stoves.

C. Exterior Shaker-Lever - For greater safety (from getting burned) and greater convenience (no need for separate tools).

IMPORTANT! WHEN SHAKING IS COMPLETED, TURN THE SHAKER UNTIL THE GRATES ARE FLAT AND HORIZONTAL. KEEP ASH DRAWER EMPTY!

## 6. Installation Instructions

### 6.1 Unpacking and Inspection of Parts

Inspect the unit for visible damage. Stove parts and accessories are packaged inside the stove. It is recommended that the owner remove these parts prior to proceeding with the installation to avoid parts damage.

NOTE: The doors, grates, and firebrick can be easily removed to lighten the weight prior to moving and placing the stove.

### 6.2 Warnings

All stoves must be installed in accordance with state and local building codes.

### 6.3 Locating The Stove

Locate the stove as close to the chimney or flue as possible.

Locate stove where there is sufficient air supply for ventilation and proper combustion to comply with the minimum clearance required for fire protection and accessibility.

### 6.4 General Information

#### Installation Checklist:

A. Have only a qualified stove installer install the stove.

B. Before starting installation, check for proper clearance to combustibles and where the stove will be located.

C. Chimney - Have chimney inspected for:

1. Proper type, Class "A" only, masonry or all-fuel factory-built.

2. Good physical and mechanical condition.

3. If manufactured chimney, look for listing mark and installation in accordance with manufacturer installation instructions.

4. Multiple venting should be avoided wherever possible. Never install your stove into the same vent as a gas furnace.

5. Check for proper roof clearances. See pg. 3 and check your local codes.

6. Chimney must be two feet higher than anything ten feet around it.

D. Flue Pipe

1. Chimney should be within 8 feet of the stove.

2. No more than two 90 degree elbows should be used.

E. Check for Proper Draft

The chimney used must be capable of providing a minimum of .06 inches water column draft.

F. A Barometric Draft Regulator

May be used and set at .06 to .10 inches water column.

Safety and Service Clearances - Regardless if you use your stove as a separate independent stove installation or in the parallel configuration with another furnace, the following steps will apply in your decision as to where and how you will install your new solid fuel stove.

#### Clearance to combustibles

Safe stove clearance to combustible walls is 24" to rear and 33" to sides and front. Floor protection for a combustible floor should consist of a non-asbestos stove mat with a K Factor of .84. The floor protector should extend 8" to either side and 16" in front of the stove. Floor protection should also extend 2" to either side of chimney connector.

IMPORTANT! THE FLUE PIPE MUST BE 24 GAUGE OR THICKER.

When connecting the flue pipe to the stove the first section of the pipe

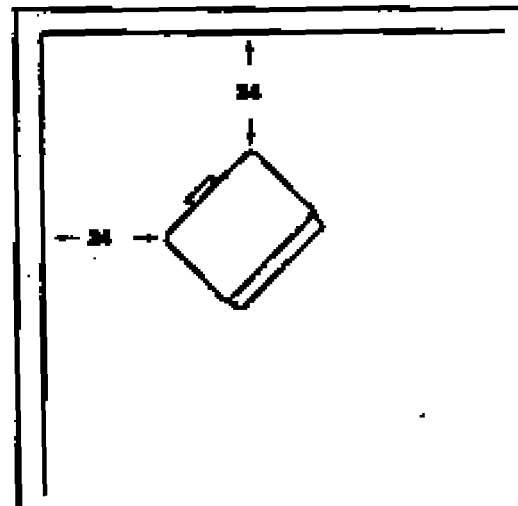
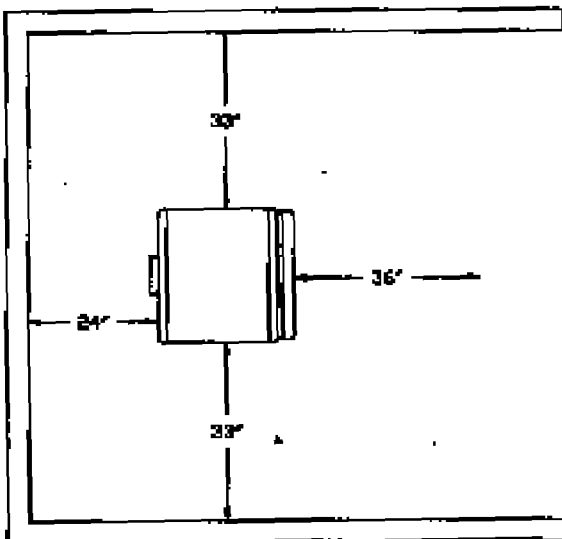

or the elbow should be installed inside the flue connector on the stove. It should be held in place by drilling three holes through the pipe. The holes should be of suitable diameter for the sheet metal screws or pop rivets used for fastening.

A straight section of pipe or an elbow must now be installed.

A barometric damper may be installed on this vertical section of the pipe. Use a listed barometric damper.

**IMPORTANT! ALL HORIZONTAL RUNS SHOULD HAVE A 1/4" RISE TO THE FOOT SO THAT ANY LIQUID THAT MAY DEVELOP WILL RUN BACK INTO THE STOVE.**

**Connector thru Walls and Chimney**

NFPA 211 does not permit a chimney connector to pass through any floor or ceiling or through any fire wall or fire partition. However, where necessary, a connector may pass through a partition other than a fire partition under any of the following conditions:

A. Where a ventilated type metal thimble, (see figure 4) is used. Such a thimble must be at least 12 inches larger in diameter than the chimney connector.

B. Where a metal or burned fire-clay thimble is used and the thimble is surrounded on all sides by not less than 8 inches of brickwork or equivalent fire-proofing material.

Figure 5: Connecting smokepipe (Connector) to Chimney Through Wall.

Two methods of connecting a chimney connector to a chimney flue where the connector must pass through a combustible partition wall. Instead of the asbestos board shown, sheet metal may be used, or a metal lath and plaster finish may be applied at that area. Use 24 gauge or heavier metal. Clearance needed is three times the diameter of stovepipe.

Figure 4. Thimble for Passing Smokepipe (Connector) Thru Walls

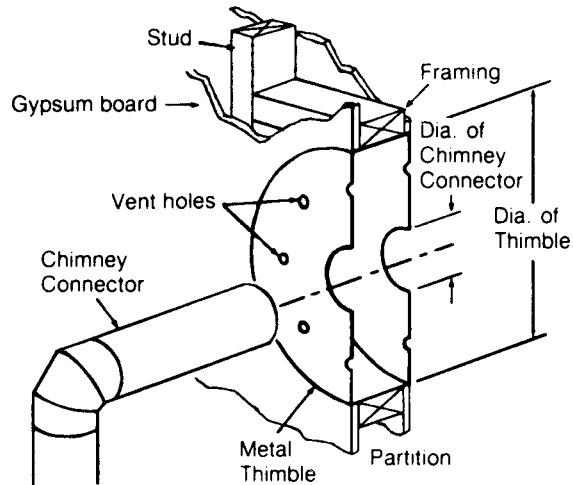

C. Where all combustible material is cut out of the partition wall for a sufficient distance to provide not less than 18 inches clearance on all sides of the connector. Any material used to close this opening must be noncombustible insulating material.

D. Where the section of connector pipe passing through the wall is replaced by a properly installed section of factory-built chimney, the chimney section must be listed for solid fuel use and be insulated.

Where an existing chimney is used, it must be large enough to provide a draft adequate for exhausting the gaseous products of combustion. The cross-sectional area of the chimney flue should be at least 25 percent greater than that of the chimney con-

connector (stovepipe). For example, the common 8 inch by 8 inch chimney flue liner has an actual interior cross-sectional area of only 49 square inches (7" x 7") and, thus, can only accommodate a 7" stove connector.

## 7. Preventive Maintenance Instructions

### 7.1 Periodic and Normal Everyday Maintenance

Blower Motor - Oil twice yearly.

Grates - Keep ash drawer emptied. Failure to do this may cause grates to warp.

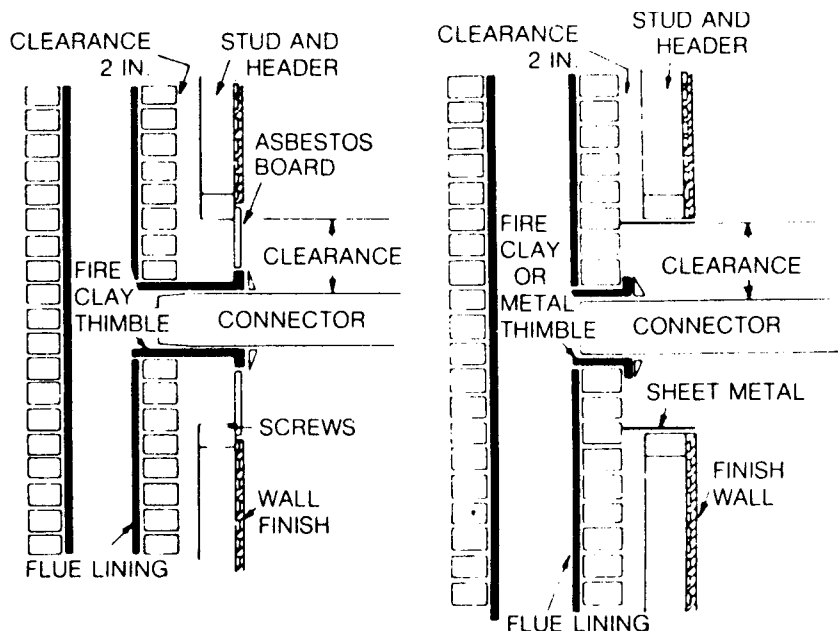



**CAUTION! BEFORE CLEANING CHIMNEY AND SMOKE PIPE BE SURE FIRE IS OUT AND INSIDE OF STOVE IS COOL.**

### Cleaning The Chimney and Smoke Pipe

Avoid chimney fires. On a regular schedule, check for creosote and soot buildup in the chimney, smoke pipe and spiral chamber. They must be kept clean. Keep a professional chimney sweep in mind if you have access to one.

Steel brushes are the safest for cleaning metal surfaces. Salt solutions and some chemicals may damage metal surfaces. Do not overfire your stove. Do not burn anything that combusts in seconds. Excessive flue temperatures may result thereby igniting creosote.

To clean the chimney, obtain a stiff brush with an extendible handle and insert the brush into the chimney from the top. Continue the brushing and sweeping downward until the entire length of the chimney is cleaned.

After cleaning the chimney, the debris will be at the bottom of the chimney at the clean-out opening. Open the clean-out door and sweep the debris out into a metal container.

The smoke pipe from the stove to the chimney can be cleaned with a steel brush.

## **8. Operating Instructions**

### **8.1 Starting a Coal Fire**

Take about eight sheets of newspaper, crumble into balls and place on top of grates. Next, lay fine kindling on top of the paper. This kindling must be dry and no larger than 3/4" in diameter. Layer the kindling in a criss-cross fashion to allow good air flow. Open the draft control fully and light the paper just inside the door. Now, close the

loading door and allow the kindling to catch fire. After a few minutes, open the loading door an inch or two for a few seconds before opening completely. This method will allow smoke to clear away from the door opening before the loading door is completely opened.

Add small, compact pieces of hardwood when the kindling is burning hot. Keep the draft controls fully open to establish a hot fire quickly. The ash door also may be opened during start-up to accelerate the initial burn.

When a substantial bed of red wood coals are built up, start adding coal (pea or nut is preferred to stove coal for starting) small amounts at a time. Keep the draft control open.

Continue adding small amounts of coal until there is a solid bed of burning coal. Do not add too much at one time. Allow sufficient time between each small loading (at least 5-10 minutes), so that each loading has time to ignite thoroughly before the next load is put in. When a substantial bed of burning coals has been established, fill the stove to the top of the firebrick. A deep bed of coal always will burn more satisfactorily than a shallow bed.

When most of the wood is burned and the coal is completely ignited (usually 5-10 minutes or less after filling the stove), the draft control should be turned down to the proper operating level. (If the ash door has been opened, it must be closed to prevent overfiring, which can cause dangerously high temperatures.)

### **8.2 Loading**

Coal should never be added unless there is a reasonable hot fire. The coal bed should be bright and vigorous.

If the fire is burning hot and there is a deep bed of coals, full loads of coal can be added at any time. However, if there is not a deep bed of coals, it is best to add small amounts of coal at first.

### **8.3 Increasing Heat From a**

### **Low Fire**

Every effort should be made not to let a coal fire burn too long so that the fire has started to die. This will cause the reloading process to be much longer, and there is a good possibility of losing the fire.

Do not shake or stir with a low fire.

Open the draft control wide or open the ash cleanout door to get the maximum draft.

Run the stove with the draft control or ash door fully open until the fire is reasonably hot.

Start adding small amounts of coal. When the new coal is thoroughly ignited or there is a substantial bed of hot coals, the stove may be shaken thoroughly. Be sure to shake down all ashes (but do not overshake).

After shaking, keep the bottom draft control open until you are sure the fire is continuing to burn hot, then turn the draft control down to the proper operating level. **IF THE ASH DOOR HAS BEEN OPENED, BE SURE TO SHUT IT (SERIOUS DAMAGE CAN RESULT IF THE STOVE IS RUN FOR EXTENDED PERIODS WITH THE ASH DOOR OPEN).**

Count the exact number of turns from full shut to the normal operating positions so that you can adjust the stove to the exact level of heat output and length of burn you desire.

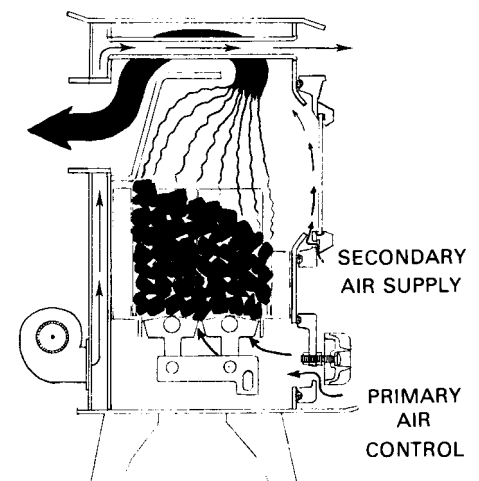

Figure 7

## 8.4 Shaking

Shaking should be done only when there is a hot fire.

The frequency of shaking will depend on the type of stove and the degree of burning. Shaking should be done at least once a day, and preferably twice a day.

Best results from shaking with Harman grates will occur if short “choppy” strokes are used rather than long, even strokes.

The amount of shaking is critical. Too little or too much, either can result in the extinguishing of a fire due to blocked air flow. The proper amount normally occurs when red coals first start to drop through onto the bed of ashes.

## 8.5 Draft Controls

The heat output of the coal is controlled by the primary draft control on bottom door. Experience will dictate the proper settings for heat requirements.

Coal responds very slowly to changes in the draft settings. Because of this slow response time, over-correcting is a common problem. When changes in heat output are needed, make only small changes in the draft setting and wait for the temperature to stabilize.

## 8.6 Ashes

Ashes should never be allowed to accumulate in the ash pit so that they in any way impede the flow of combustion air to the fire. Excess ash accumulation can cause the fire to go out and also can cause severe damage to the grates because of the absence of a cooling flow of air beneath them.

Ashes should be placed in a metal container with a tight fitting lid. The closed container of ashes should be placed on a noncombustible floor or on the ground, well away from all combustible materials, pending final disposal. If the ashes are disposed of by burial in soil or otherwise locally dispersed, they should be retained in the closed container until all cinders have

thoroughly cooled outside the dwelling.

**CAUTION! ASHES SHOULD NEVER BE ALLOWED TO ACCUMULATE ABOVE THE TOP OF THE ASH PAN. ASHES IN CONTACT WITH THE BOTTOM OF THE GRATES ACT AS AN INSULATOR, INTENSIFYING THE HEAT ON THE GRATES, AND COULD CAUSE THEIR WARPAGE. WITH AN EXCESSIVE ASH BUILDUP, PRIMARY COMBUSTION AIR IS RESTRICTED, THUS, THE UNIT'S OUTPUT COULD BE REDUCED.**

**GRATES DAMAGED IN THIS WAY ARE EASILY RECOGNIZED BY THE EXTREME DAMAGE CAUSED TO THE GRATES.**

**PLEASE REFER TO YOUR WARRANTY TO SEE HARMAN STOVES LIMIT OF LIABILITY IN CASES OF ABUSE OR NEGLECT.**

Coal produces considerably more ash than wood, so the intervals between emptying are much shorter. For equal heat output, coal will produce seven to ten times more ash than wood.

## 8.7 Safety

Whenever a loading door is opened, it always should be cracked slightly to allow oxygen to enter and burn any combustion gases that are present before fully opening. Failure to do this could result in sudden ignition of the unburned gases when the door is opened.

A stove never should be filled with excess coal so that the flue gas exit is blocked or impeded in any way. Burning coal generates carbon monoxide. If the flue gas exit is blocked, the carbon monoxide can be forced out of the stove into the room, with possible fatal consequences.

**WITH THE EXCEPTION OF THE START-UP PERIOD, THE ASH PIT DOOR SHOULD NEVER BE LEFT OPEN. ALSO NOTE THAT A STOVE SHOULD NEVER BE LEFT UNATTENDED WITH THE ASH PIT DOOR OPEN.**

Serious damage to the stove can occur from overheating.

Coal stoves should not be installed in any chimney that has had a history of back-drafting or flow reversal. These conditions can cause improper draft, resulting in carbon monoxide entering the house rather than being drawn up the chimney. **REMEMBER! COAL GASES ARE TOXIC!**

Sulfur dioxide, sulfur trioxide and other ions released from coal burning may corrode stainless and masonry chimneys, and even terra cotta chimney liners and brick in nearby buildings. Coal with high sulfur content will destroy chimneys especially fast if soot sits in the flue for extended lengths of time. It is important to clean chimneys regularly.

# 9. Warranty

## 9.1 Terms and Warranty

Harman Stoves are warranted for five years in accordance with the following warranty terms. Exclusions to the six years will be the following items:

- A. Electrical Blower (3 year warranty)
- B. Door Packing
- C. Glass
- D. Firebricks
- E. Paint
- F. Any Damage Deemed Abuse

# 10. Warranty Activation Coupon and Liability Statement

## Instructions to Activate Your 6-Year Written Warranty

The Activation Coupon must be filled out in its entirety to have an effective warranty!

Serial number of stove is located on the right side of unit, near the front lower corner. Numbers are stamped into the steel.

Your Signature is Required!

# 11. Optional Hot Water Coil (Not Available For Mark I)

## PLUMBING DIAGRAM FOR THERMO-SIPHON METHOD - MAX. DISTANCE 10 FT.

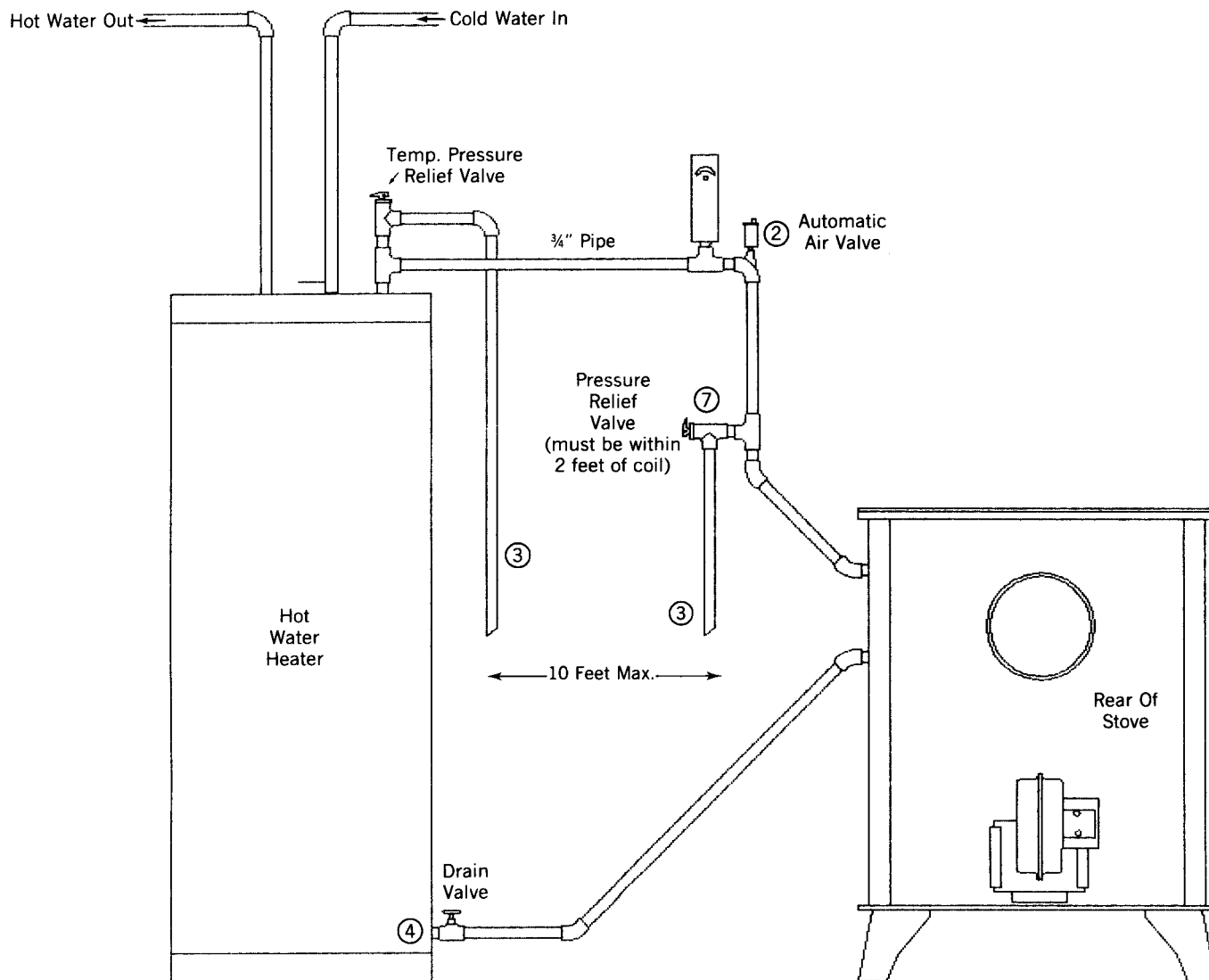

### COIL INSTALLATION (See Coil Diagram on Page 14)

Place one of the nuts supplied on each leg of the coil. Place coil through the holes in the back of the firebox and adjust the nuts so the pipes stick out about 1 1/4 to 1 1/2 inches from the side of the stove. Put flat washers and nuts on the outside and tighten within 1/4 inch. Then place fiberglass rope around each pipe the washers and tighten. You are now ready to run pipes.

### THERMO-SIPHON METHOD (LESS THAN 10 FEET)

This is the simplest and most economical method, however, the hot water tank must be less than ten feet from the stove. The water inlet, where the temp./press/relief valve is located, must be higher than the top leg of the coil. The hot water tank should be elevated, if necessary, to allow for proper thermo-siphon action (the method by which hot water will circulate automatically through the system.)

- Shut off the hot water heater and the old water supply to it. Drain the tank completely.
- Remove the temp./press/relief valve and discard. Install a short 3/4" nipple and tee (1) along with a new temp./press/relief valve.
- Run 3/4" copper tubing along with the necessary fittings between the hot water tank and the top leg of the water coil. Install a 3/4" vent elbow and automatic "float type" air vent (2) in the high point of the line. Within two feet of the top leg of the water coil install a 150 lb. pressure relief valve. (7) Run 3/4" tubing from the release exit of both relief valves downward (3) so the hot water may escape the event of overheating.
- Remove the drain valve at the bottom of the tank. Install a short 3/4" nipple and tee and re-install the drain valve to the tee (4). Run 3/4" copper tubing with the necessary fittings between the drain/tee combination and the lower leg of the coil. After all of the connections have been complete, you may refill the tank. Turn on the hot water heater only after the tank has been completely refilled.

# PLUMBING DIAGRAM FOR CIRCULATING PUMP METHOD - MORE THAN 10 FT.

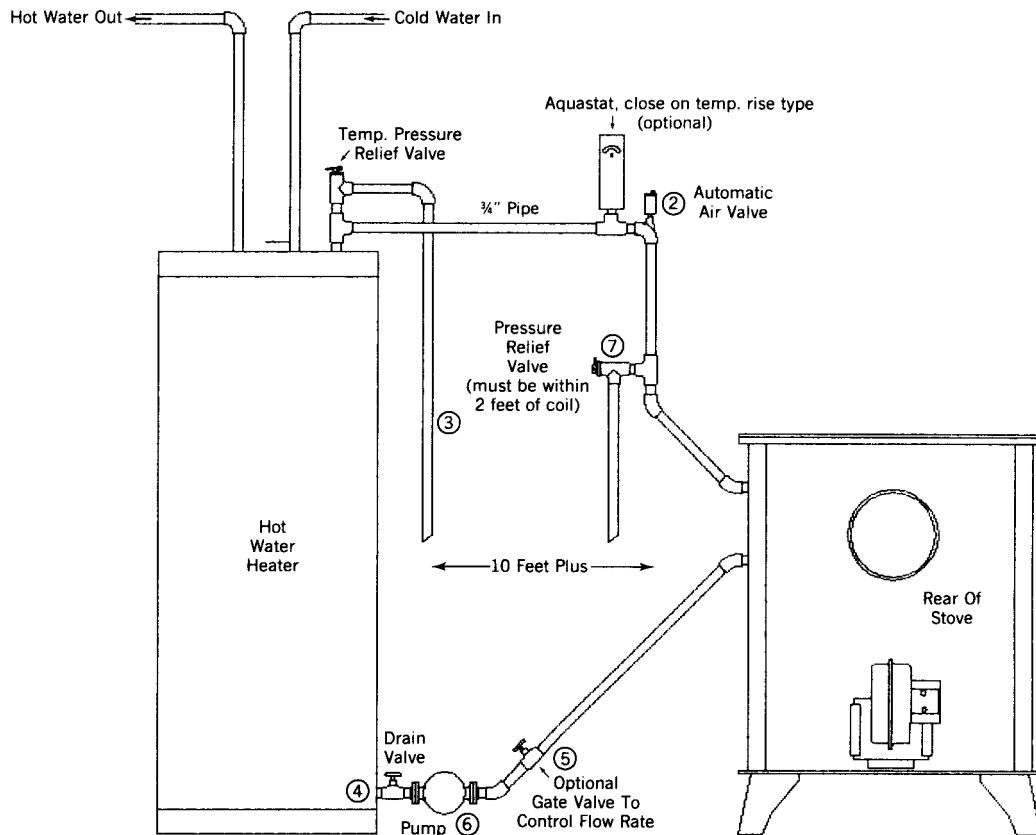

## CIRCULATING PUMP METHOD (MORE THAN 10 FEET)

This method is used when the hot water heater tank is more than ten feet away from the stove or the stove is on a higher level than the hot water heater tank. In addition to a circulator pump, you may want to add an aquastat to thermostatically control the pump according to water temperature. This is optional and not necessary if the circulator pump is left run continuously. Another option is a gate valve placed near the pump to control the rate of water flow.

- Shut off the hot water heater and the old water supply to it and drain the tank completely.
- Remove the temp./press/relief valve and discard. Install a short 3/4" nipple and tee (1) along with a new temp./press/relief valve.
- Remove the drain valve at the bottom of the tank. Install a 3/4" short nipple and tee and re-install the drain valve to the tee (4).
- Install a circulating pump (6) as shown. Run 3/4" copper tubing from the circulating pump to the lower leg of the heat exchanger coil. This is where the optional gate valve (5) can be installed to regulate the water flow.
- Install a 3/4" tee and a 150 lb. pressure relief valve (7) in the top leg within two feet of the top outlet of the water coil.
- Complete the 3/4" copper line by running it back to the tee at the top of the hot water tank, making sure to install a 3/4" vent elbow and automatic air vent (2) at the high point of the line. The optional aquastat can be installed in this line a maximum of 6 feet from the furnace. This aquastat must be a close on temperature rise type and must be wired and adjusted to turn on the circulating pump when the water temperature reaches 120 degrees F.

The system is now ready to be refilled and the hot water heater turned back on.

## COIL DIAGRAM

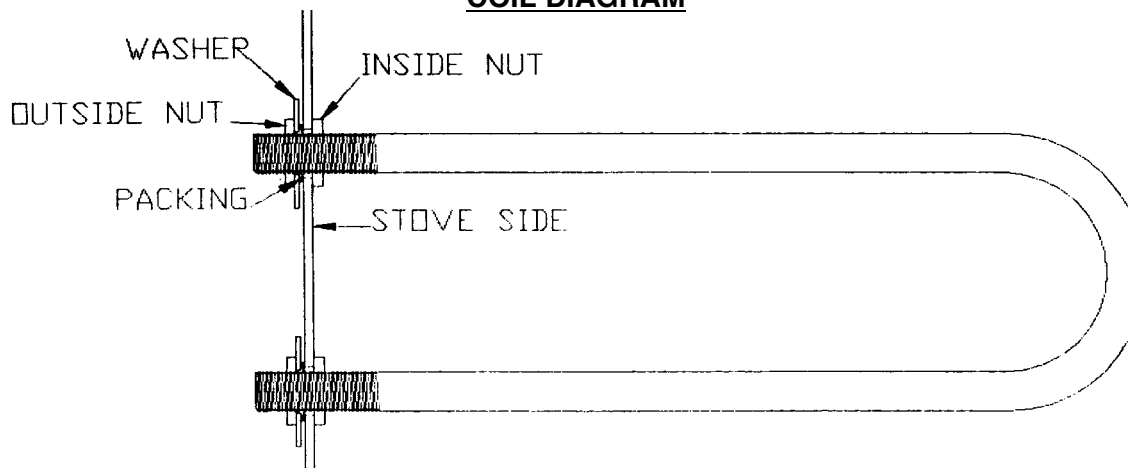

# **HARMAN GOLD WARRANTY**

## **6 YEAR TRANSFERABLE LIMITED WARRANTY (Residential)**

### **1 YEAR LIMITED WARRANTY (Commercial)**



Harman Stove Company warrants its products to be free from defects in material or workmanship, in normal use and service, for a period of 6 years from the date of sales invoice and for mechanical and electrical failures, in normal use and service, for a period of 3 years from the date of sales invoice.

If defective in material or workmanship, during the warranty period, Harman Stove Company will, at its option, repair or replace the product as described below.

The warranty above constitutes the entire warranty with respect to Harman Stove Company products. HARMAN STOVE COMPANY MAKES NO OTHER WARRANTY, EXPRESSED OR IMPLIED, INCLUDING "ANY" WARRANTY OF MERCHANTABILITY, OR WARRANTY OF FITNESS FOR A PARTICULAR PURPOSE. No employee, agent, dealer, or other person is authorized to give any warranty on behalf of Harman Stove Company. This warranty does not apply if the product has been altered in any way after leaving the factory. Harman Stove Company and its agents assume no liability for "resultant damages of any kind" arising from the use of its products. In addition, the manufacturer and its warranty administrator shall be held free and harmless from liability from damage to property related to the operation, proper or improper, of the equipment.

THERE ARE NO WARRANTIES WHICH EXTEND BEYOND THE DESCRIPTION ON THE FACE HEREOF.

THESE WARRANTIES APPLY only if the device is installed and operated as recommended in the user's manual.

THESE WARRANTIES WILL NOT APPLY if abuse, accident, improper installation, negligence, or use beyond rated capacity causes damage.

HOW TO MAKE A CLAIM - Any claim under this warranty should be made to the dealer from whom this appliance was purchased. Then contact is made with manufacturer, giving the model and serial numbers, the date of purchase, your dealer's name and address, plus a simple explanation of the nature of the defect. Extra costs such as mileage and overtime are not covered. Nuisance calls are not covered by these warranties.

THIS WARRANTY IS LIMITED TO DEFECTIVE PARTS - REPAIR AND/OR REPLACEMENT AT HARMAN STOVE COMPANY'S OPTION AND EXCLUDES ANY INCIDENTAL AND CONSEQUENTIAL DAMAGES CONNECTED THEREWITH.

WARRANTY EXCLUSIONS: Failure due, but not limited to, fire, lightning, acts of God, power failures and/or surges, rust, corrosion and venting problems are not covered. Damage and/or repairs including but not limited to; remote controls, filters, fuses, knobs, glass, ceramic brick panels, ceramic fiber afterburners, door packing, tile, ceramic log sets, paint, batteries or battery back-up and related duct work are not covered. Also excluded from this warranty are consumable or normal wear items including but not limited to; flame guides, grates, coal bars, afterburner hoods, fire brick, gaskets. Additional or unusual utility bills incurred due to any malfunction or defect in equipment and the labor cost of gaining access to or removal of a unit that requires special tools or equipment are not covered. Maintenance needed to keep the stove in "good operating condition" is not covered. This includes, but is not limited to, cleaning, adjustment of customer controls and customer education. Labor, materials, expenses and/or equipment needed to comply with law and/or regulations set forth by any governmental agencies are not covered.

This Warranty provides specific legal rights and the consumer may have other rights that vary from state to state.

In the event of change in ownership, the remaining portion of this warranty may be transferred to the new owner by sending the new owner information and a transfer fee of \$25.00 US to the Harman Stove Company.

PLEASE READ THE LITERATURE BY THE MANUFACTURER FOR THE VARIOUS ACCESSORY DEVICES. THE MANUFACTURER WARRANTS THESE ACCESSORY DEVICES, NOT HARMAN STOVE COMPANY OR THEIR WARRANTY ADMINISTRATOR. FURTHERMORE, THESE ACCESSORY DEVICES MUST BE INSTALLED AND USED ACCORDING TO THE RECOMMENDATIONS OF THE MANUFACTURER.

REMEDIES - The remedies set forth herein are exclusive and the liability of seller with respect to any contract or sale or anything done in connection therewith, whether in Contract, in tort, under any warranty, or otherwise, shall not, except as herein expressly provided, exceed the price of the equipment or part of which such liability is based.

CLARIFY - The above represents the complete warranty, which is given in connection with stoves, manufactured by Harman Stove Company. No other commitments, verbal or otherwise, shall apply except by a written addendum to this warranty.

WARNOCK HERSEY  
NRB REPORT NO. 219  
ICBO REPORT NO. AA549



TESTED TO UL 737,  
UL 1482, JUNE, 1985

LISTED SOLID FUEL FIREPLACES  
STOVE OR ROOM HEATER

MODEL: MARK I   
MARK II   
MARK III

WHI-

**DO NOT REMOVE THIS LABEL**

**MINIMUM CLEARANCES TO COMBUSTIBLE MATERIALS**

A.	UNIT TO SIDEWALL	33"
B.	UNIT TO BACKWALL	24"
C.	CHIMNEY CONNECTOR TO SIDEWALL	42"
D.	CHIMNEY CONNECTOR TO BACKWALL	18"
E.	FLOOR PROTECTOR, SIDE AND REAR	8"
H.	FLOOR PROTECTOR, FRONT	16"

CHIMNEY CONNECTOR TO COMBUSTIBLES 18" MINIMUM  
FLOOR PROTECTION: UNIT MUST BE PLACED ON NON-COMBUSTIBLE FLOOR OR USE A 3/8" ASBESTOS MILLBOARD PROTECTOR OR EQUIVALENT EXTENDING OUT 8" TO THE SIDE AND REAR, 16" IN FRONT.

USE CLASS "A" CHIMNEY AND CLASS "A" CHIMNEY CONNECTOR. SPECIAL METHODS ARE REQUIRED WHEN PASSING THROUGH A COMBUSTIBLE WALL OR CEILING. SEE INSTRUCTIONS AND LOCAL BUILDING CODES.

INSTALL AND USE ONLY IN ACCORDANCE WITH THE MANUFACTURER'S INSTRUCTIONS AND LOCAL BUILDING CODES. CONTACT LOCAL BUILDING OR FIRE OFFICIALS ABOUT RESTRICTIONS AND INSTALLATION INSPECTION IN YOUR AREA.

FUEL: FOR USE WITH COAL.

ELECTRICAL RATING: 115 VOLTS, 1.1 AMPS, 60 HZ.

DO NOT OBSTRUCT SPACE UNDER HEATER.

DO NOT CONNECT THIS UNIT TO A CHIMNEY FLUE SERVING ANOTHER APPLIANCE.

DO NOT OVERFIRE - IF FIREPLACE STOVE OR CHIMNEY CONNECTOR GLOWS, YOU ARE OVERFIRING. INSPECT AND CLEAN CHIMNEY FREQUENTLY - UNDER CERTAIN CONDITIONS OF USE, CREOSOTE BUILDUP MAY OCCUR RAPIDLY.

HARMAN STOVE AND WELDING, INC.  
R.D. #1, BOX 619  
HALIFAX, PA. 17032

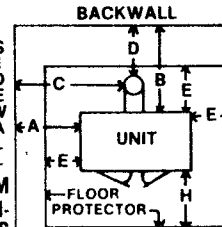

Do Not Remove From Manual

