

BeoLab 3500 MKII

Type 1601, 1602, 1603, 1604, 1605, 1607, 1608
from serial no. 19343452

Service Manual
English

German and French, versions are available in the Retail System

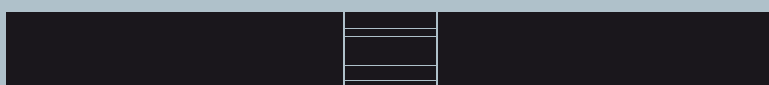

CONTENTS

| | |
|--|-----------|
| Survey of modules | 1.1 |
| Adjustments | 2.1 |
| Repair tips | 3.1 |
| Disassembly | 4.1 |
| Insulation test | 5.1 |
| Specification guidelines for service use | 6.1 |
| Wiring diagram | 7.1 |
| Block diagrams | 7.3 – 7.5 |
| Available parts | 8.1 |

Seen from the front

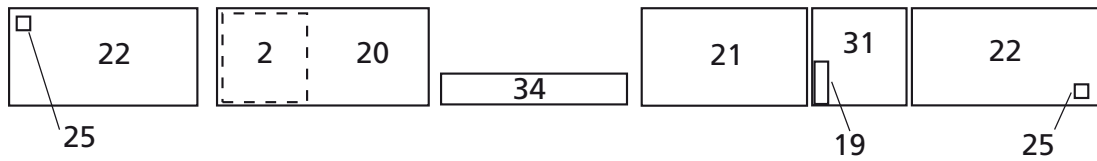

Seen from the back

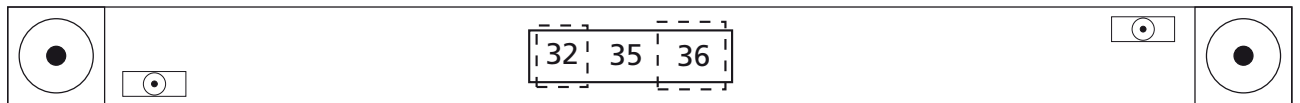

- 2 Switch Mode Power Supply
- 19 DC/DC Converter
- 20 Transformer left
- 21 Transformer right
- 22 Power Amplifier left
- 22 Power Amplifier right
- 25 NTC
- 31 LF Supply and Control
- 32 Cross Field
- 34 Plug PCB
- 35 Display, Keyboard and IR Receiver
- 36 Microcomputer

ADJUSTMENTS

5V

When replacing IC1, LM3578, on PCB2, Switch-Mode Power Supply, the supply voltage may have to be adjusted to $5V \pm 0.25V$ by means of R2 and R10:

- If 5V is above level, install R2 (R1//R2).
- If 5V is below level, install R10 (R3//R10).

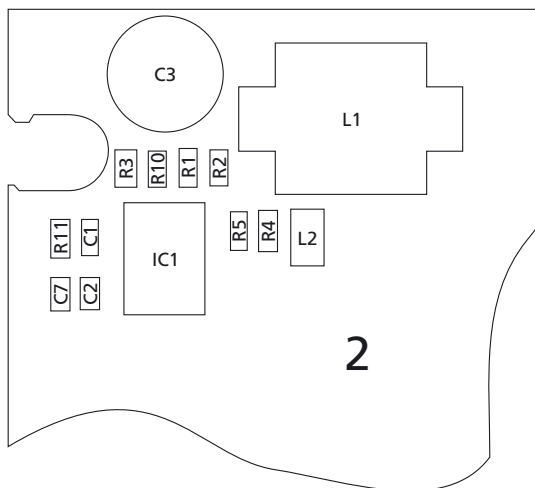

SPEAKER

Adjustment of bass/treble sound level.

To be carried out only when replacing a speaker unit or PCB36, Microcomputer.

TEST MODE 01

This test mode permits manual adjustment of speaker bass and treble levels and can only be executed from stand-by with a Beo4.

- Press **MENU 0 1 GO**.
The display reads SPK.CAL. to indicate that the product is ready for speaker calibration.
- Press **GO**.
The display shows the present adjustment:
'X X X X' = left bass (LB).
'X X X X' = left treble (LT).
'X X X X' = right treble (RT).
'X X X X' = right bass (RB).

The value that can be changed is flashing. Press >> or << to change unit of adjustment, and change the value by pressing the digit keys. When all four speakers have the desired encoding, press **STORE**, and abandon test mode by pressing **STOP**.

Replacement of PCB36, Microcomputer

The bass and treble levels of the speakers are stored electronically in the Microcomputer (PCB36). When replacing PCB36, the original bass and treble level values must be restored:

- Install the new Microcomputer (see section 4, Disassembly, if necessary).
- In TEST MODE 01, enter the values printed on the label in the socket well:
LT (left treble) : X LB (left bass) : X
RT (right treble) : X RB (right bass) : X
- Press **STORE STORE** when all four speakers have been encoded as desired.

Replacement of a speaker unit

A rated value in dB is printed on the back of the new speaker unit. This value is used for adjusting the sound level, which is done in TEST MODE 01:

- Note the value on the back of the new speaker unit
- Replace the old speaker unit.
- Execute the point TEST MODE 01.
- The rated value printed on the back of the speaker may be either positive or negative:

Positive:

If the rated value printed on the back of the speaker is positive, the unit in question must be damped by X number of steps. Press >> to select speaker, if necessary (the active speaker is flashing), and enter a new digit (see table).

Negative:

If the rated value printed on the back of the speaker is negative, the other three units must be damped by X number of steps. Press >> to select the three speakers in question, and enter new digits (see table).

| Rated value in dB | X steps down |
|-------------------|--------------|
| 0.00 | 0 steps down |
| +/-0.25 | |
| +/-0.50 | |
| +/-0.75 | 1 step down |
| +/-1.00 | |
| +/-1.25 | |
| +/-1.50 | |
| +/-1.75 | |
| +/-2.00 | 2 steps down |

- Press **STORE** when all four speakers have the desired encoding.
- Abandon test mode by pressing **STOP**.

REPAIR TIPS

BeoLab 3500 can be brought into TEST MODE from stand-by with a Beo4, giving access to the following functions:

TEST MODE 00

Display of: Software version number and time of operation in Audio mode, Video mode and stand-by.

- Press **MENU 0 0 GO**.
The display reads: **SW X.Y**, which is the software version number.
- Press **▲**.
The display reads: **A: XXXXX**, which is the Audio mode operating time in hours x 10.
- Press **▲**.
The display reads: **B: XXXXX**, which is the Video mode operating time in hours x 10.
- Press **▲**.
The display reads: **C: XXXXX**, which is the stand-by operating time in hours x 10.
Press **▲** or **▼** to scroll in the scroll menu, and abandon test mode by pressing **STOP**.

TEST MODE 01

Electronic adjustment of the bass and treble levels of the speakers. See section 2, Adjustments.

SERVICE SET-UP

BeoLab 3500 is connected to a Beomaster as an ordinary Master link installation. As regards option programming, see User's Guide.

TEST MODE 02

Display of Master Link error types. Gives an identification of the error types that may occur in the Beolink installation.

- Press **MENU 0 2 GO**
The display reads:
ML OK = The Master Link connection is OK.
Or
NO ML = Master Link is not connected.
Or
ERROR 1 = Address configuration impossible.
Or
ERROR 2 = Master Link data pulled low.
Or
ERROR 3 = Master Link data pulled high.
Or
ERROR 4 = Data collision on Master Link.
- Press **STOP** to abandon display of Master Link error types and to delete registered errors.

The Master Link error system is a part of the software in the product. It registers communication errors between the microcomputer, the data transceiver circuits (PCB35) and the products connected to BeoLink. The error types will be described below, and tips will be given regarding how the cause of the error can be found:

ERROR 1:

Error during address configuration. No address has been allocated because too many units are connected to the BeoLink.

- Remove all products from BeoLink, and connect them again one at a time until the error code occurs. Disconnect that product from BeoLink.

ERROR 2:

It is not possible to transmit on BeoLink, because it has been pulled low. The error may occur if there is no Master Link driver circuit, or as a result of a physical short-circuit on BeoLink or in the data transceiver circuits.

- Disconnect one product from BeoLink at a time, and see if it starts up.
- Reset the faulty product, and check the connection (cable/plug) and signal path (the data transceiver circuits).

ERROR 3:

It is not possible to transmit on BeoLink, because it has been pulled high. This error is caused either by the pull-up resistance in the system having become too small or by an error in the data transceiver circuit.

- Disconnect one product from BeoLink at a time, and see if it starts up.
- Reset the faulty product, check whether the Master Link cable is too long, and check the signal path (the data transceiver circuit).

ERROR 4:

The data traffic on BeoLink has been excessive, or a product has jammed and will not receive telegrams.

- Press the operating sequence again.
- Disconnect one product from BeoLink at a time to determine which product has jammed. Reset the faulty product, and check the Master Link connection (cable/plug) and signal path (amplifiers in the data transceiver circuit).

TEST MODE 0 3

Direct selection of Master Link input. Permits the Master Link signal path to be tested without having a BeoLink master connected.

- Press **MENU 0 3 GO**
The display reads:
ML SEL. = Opens the Master Link signal path.
- Press **STOP** to close the Master Link signal path.

DISASSEMBLY

Front fabric frame

- Push the front fabric frame to the side and lift it off.

When both front fabric frames have been removed, PCB35, Display, Keyboard & IR receiver, PCB36, Microcomputer, and PCB32, Cross field, are accessible:

- Remove the display glass (two screws) and the two plastic covers (four screws). PCB35 can now be tilted out into service position, thereby also providing access to PCB36 and PCB32.

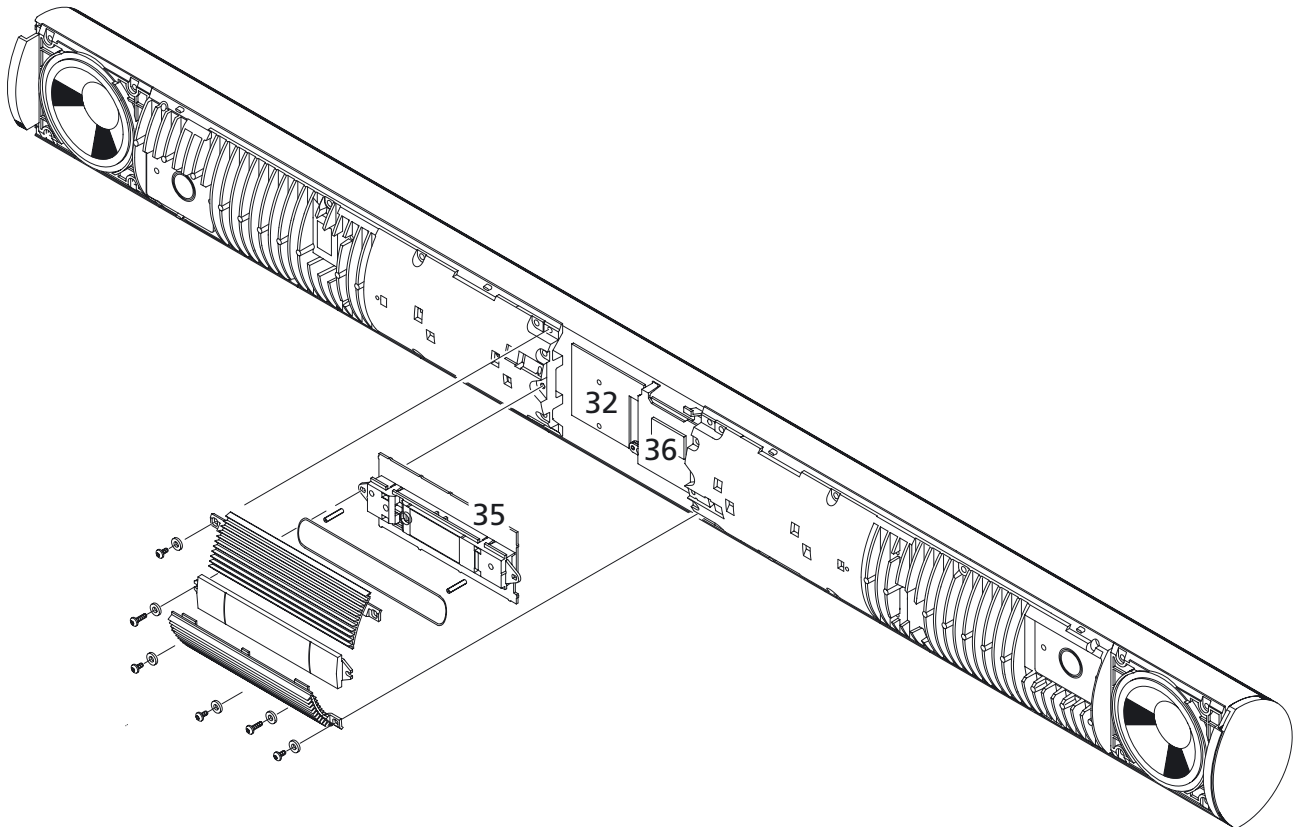

Service position

Important!

The display glass and cabinet must be protected against scratches by placing them on a soft base.

- Remove the sixteen screws, A, behind the front fabric frames.
- Place the front face down.

- Remove the socket well by first removing the two Allen screws.

- Lift the cabinet up and off carefully. Place the cabinet parallel to the electronics block, and remove the two woofer plugs (22P4) if necessary.

- When assembling the product, lower the electronics block carefully down into the cabinet. Place the woofer leads at the centre of the cabinet so that they will not rattle against the cabinet sides.

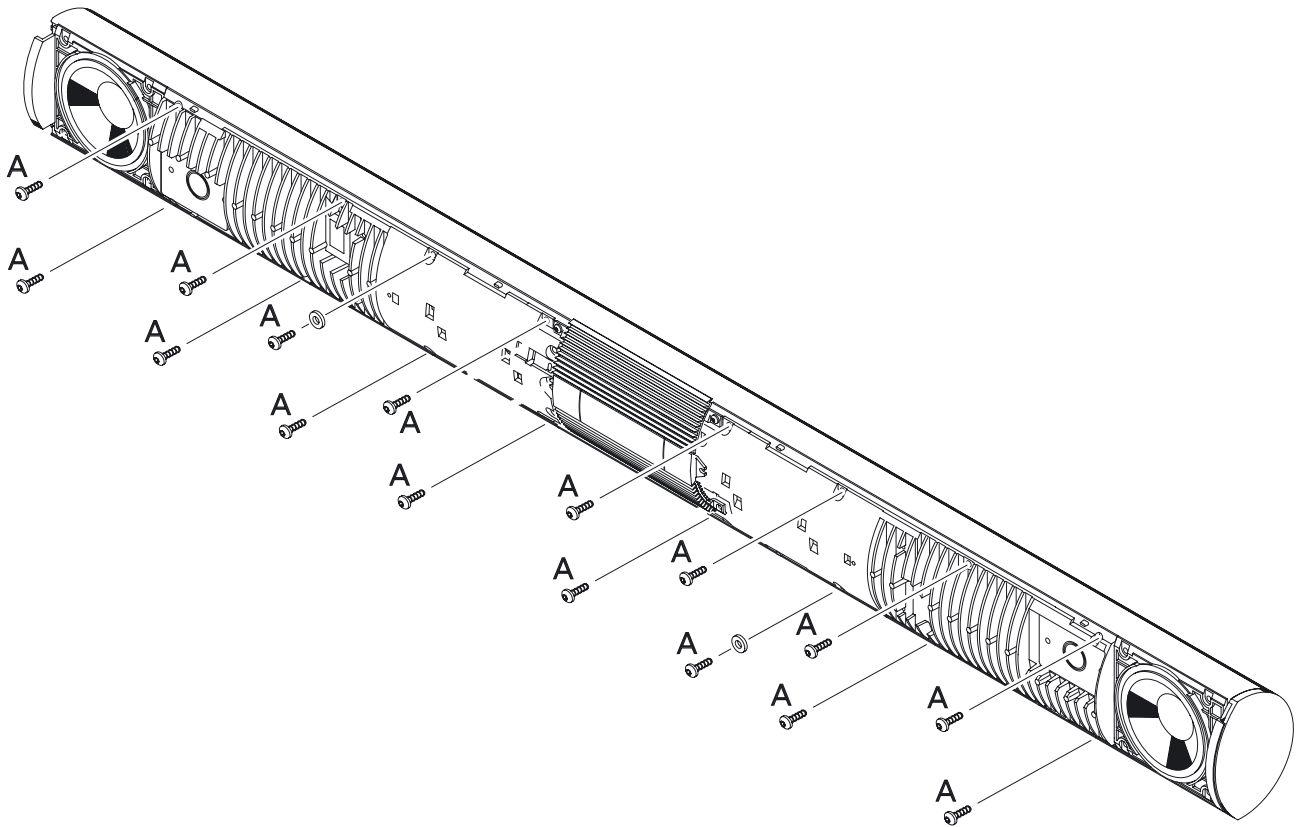

INSULATION TEST

Each set **must** be insulation tested after dismantling. The test is to be performed when the set has been re-assembled and is ready for delivery to the customer.

Make the insulation test as follows: Short-circuit the two plug pins of the mains plug and connect one of the terminals of the insulation tester. Connect the other terminal of the insulation tester to the chassis of the 8-pin DIN socket.

N.B.!

To avoid ruining the set, it is essential that both insulator test terminals are in really good mechanical contact.

Now turn slowly the voltage control of the insulation tester until a voltage of 1.3kV is obtained. Hold it there for 1 second, then turn slowly the voltage down again.

At no point during the testing procedure any flash-overs are permissible.

SPECIFICATION GUIDELINES FOR SERVICE USE

| | |
|------------------|---|
| BeoLab 3500 MKII | Type 1601 (EU), 1602 (GB), 1603 (USA-CDN), 1604 (JAP), 1605 (AUS) 1607 (KOR), 1608 (CHK) |
|------------------|---|

Concept

| | |
|--------------------|--|
| X-tra room product | Active stereo loudspeaker with control circuitry, stand-by relay and IR receiver |
|--------------------|--|

Operation

| | |
|---------------------------|--|
| Local operation | Two sensi-touch fields with restricted operation (Mute/on/off/listen-in, timer on/off) |
| Remote operation | Beolink 1000 or Beo4, one-way (optional extra) |
| Status feedback | Red 8 char. LED dot matrix display, (program source, program or track number, record, clock) |
| Independent sound control | Red LED 1.8mm (Timer indication) |
| Compatibility | Volume, balance, bass, treble, loudness Master Link Wireless 1 via 8-pin DIN plug |

Cabinet

| | |
|--------------|--------------------------------|
| Rear finish | Polished aluminium, high gloss |
| Front cloth | Black |
| Center front | Black aluminium/plastic |
| Wall bracket | Grey plastic |

Placement

| | |
|-------|-------------------------------------|
| Wall | Wall bracket included |
| Stand | Polished aluminium (optional extra) |

Acoustics

| | |
|--------------------------------|---------------|
| Cabinet net volume per channel | 0.8 litres |
| Woofers in each channel | 9 cm - 3½" |
| Tweeter in each channel | 1.8 cm - 3/4" |
| Crossover frequency | 3000 Hz |
| Bass reflex principle | Port |

Electronics

| | |
|--------------------------|------------------------------------|
| Overload protection | Yes |
| Volumecontrol | +12 dB in relation to central room |
| Bass/treble equalization | ±12 dB, 100Hz/20kHz |

System data

| | |
|-------------------------------------|---|
| Principle | Active, Bass reflex, 2-way, bi-amp, stereo |
| Frequency response | 70 - 22.000 Hz +4 -8 dB, half field |
| Sound Pressure Level | 95 dB weighted noise (IEC 268-5), stereo, half room, 3m |
| Harmonic distortion 250 - 1,000Hz | <10% 94 dB SPL, 1m |
| Harmonic distortion 1,000 - 5,000Hz | <3% 94 dB SPL, 1m |
| Minimum distance to TV | 25cm |

Power amplifiers

| | |
|---------------------------------|-----------------------------|
| Rated power woofer | 35W, 8Ω |
| Rated power tweeter | 35W, 8Ω |
| Amplifier signal-to-noise ratio | > 80 dBA, 1W/8Ω |
| Signal-to-noise ratio | > 74 dBA, full volume |
| Frequency range | 20 - 20,000 Hz +0 -1 dB |
| Harmonic distortion | < 0.1% |
| Total harmonic distortion | < 0.3% IHF |
| Cross talk | 50 dB |
| Active crossover network | 24 dB/octave Linkwitz/Riley |
| Low frequency equalization | +12 dB/60 - 250 Hz, ABL |
| High pass filter | 30 dB/octave, 60 Hz |

Connections

| | |
|-------------------------|---|
| Mains | Cable included, 3 meters 230V AC, 1601 EU, 1607 KOR, 1608 CHK 240V AC, 1602 GB and 1605 AUS 120V AC, 1603 USA - CDN 100V AC, 1604 JAP |
| BeoLink Wireless 1 (W1) | 8-pin DIN 45326 socket |

Dimensions

| | |
|--------------------------------------|--|
| Total dimensions W x H x D (on wall) | 111 x 9.5 x 11 cm |
| Power consumption, operation | 95 watts (230V) |
| Power consumption, stand-by | 1.1 watt, 'Dot' in display 3 watt, 'Watch' in display |
| Weight | 10 kg, without stand |

Optional accessories

| | |
|--------------|----------------------------|
| Beo4 | Type 1627 |
| Wall bracket | Type 1607 - 3031302 |
| Wall bracket | 3031235 |
| Wall plate | 3031333 |
| Table stand | Type 1606 - 1160611 |
| Cable cover | 2560276 (10 pieces x 2.5m) |

Subject to change without notice

Wiring diagram

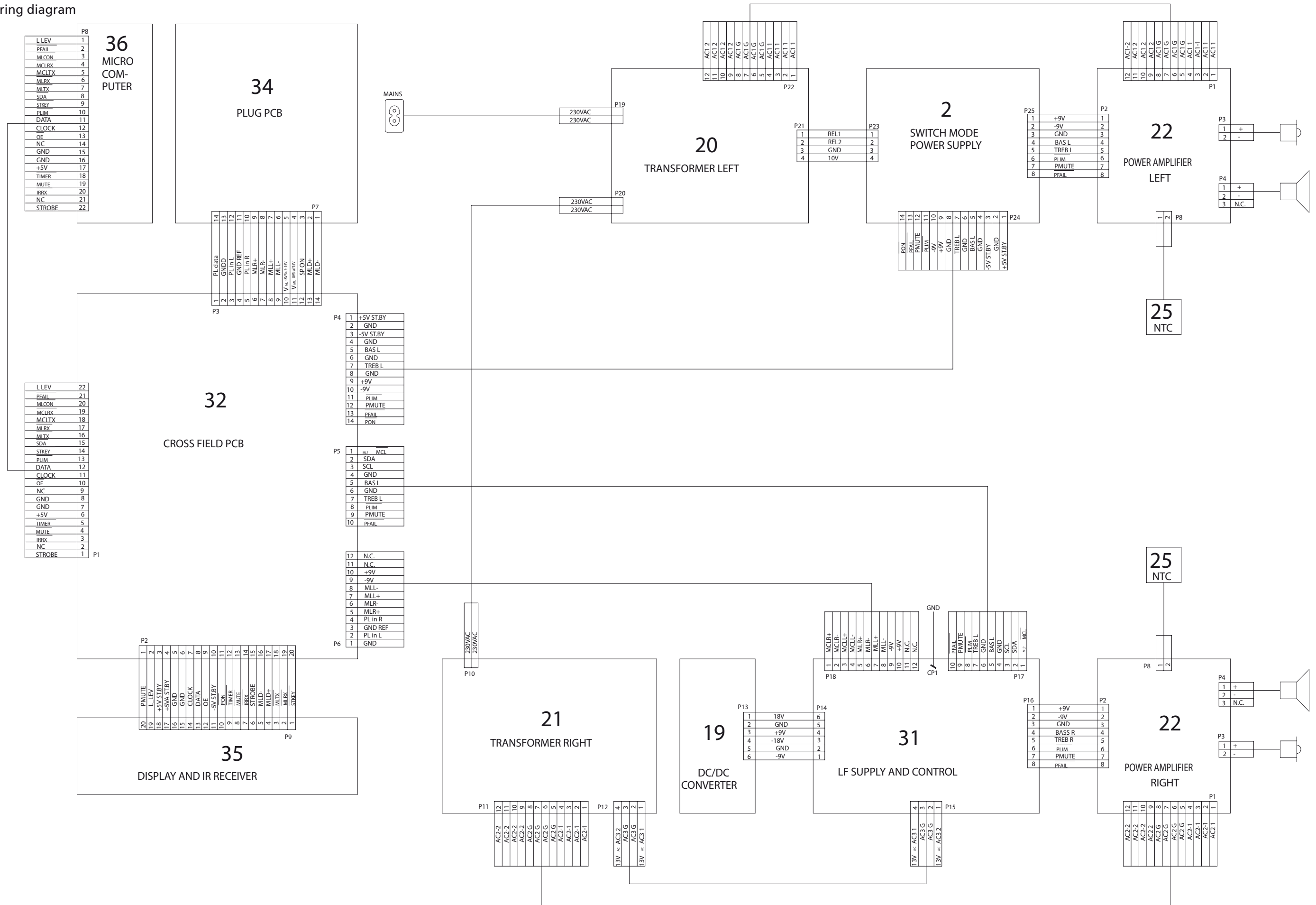

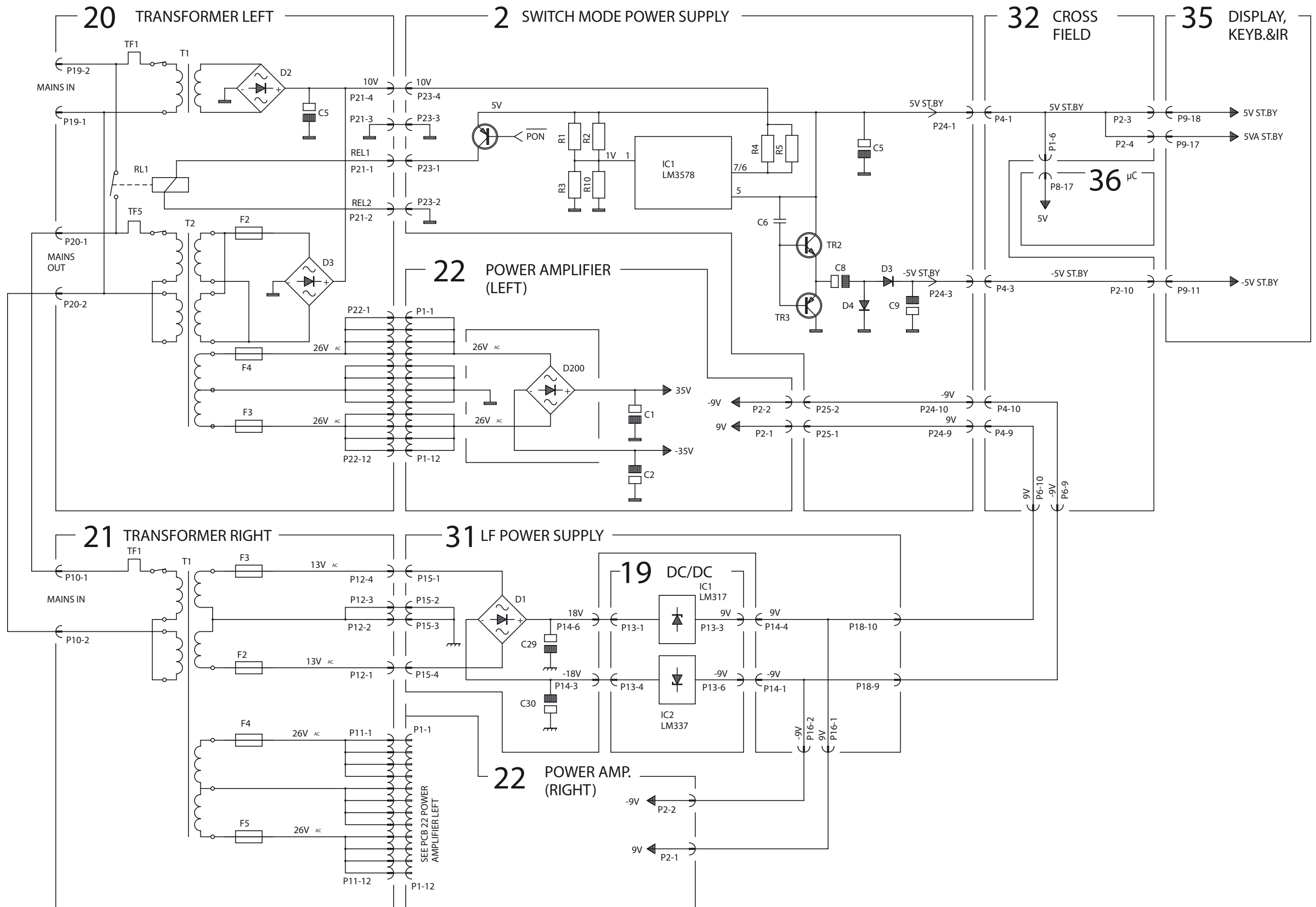

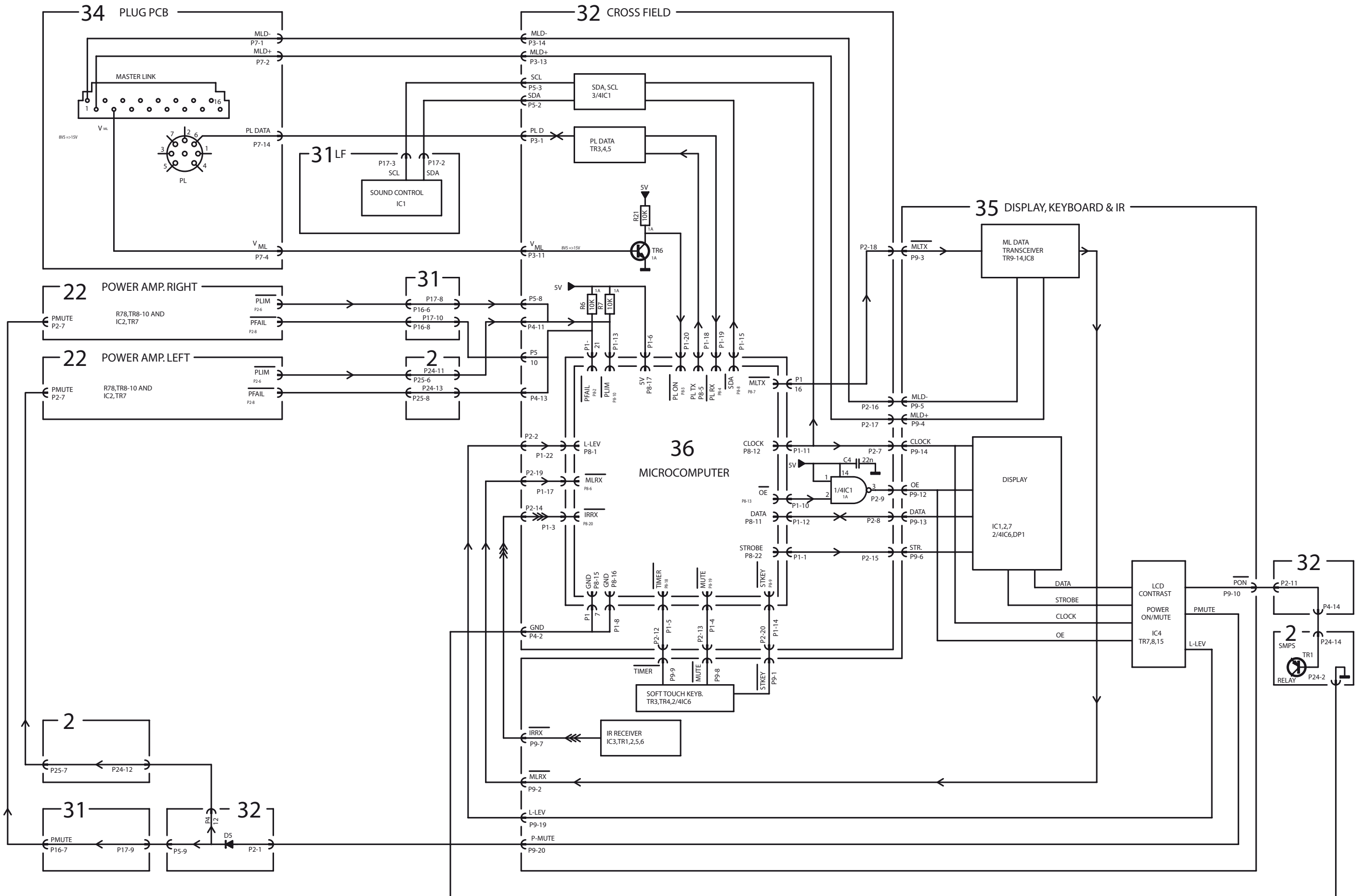

Block diagram for Power amplifier

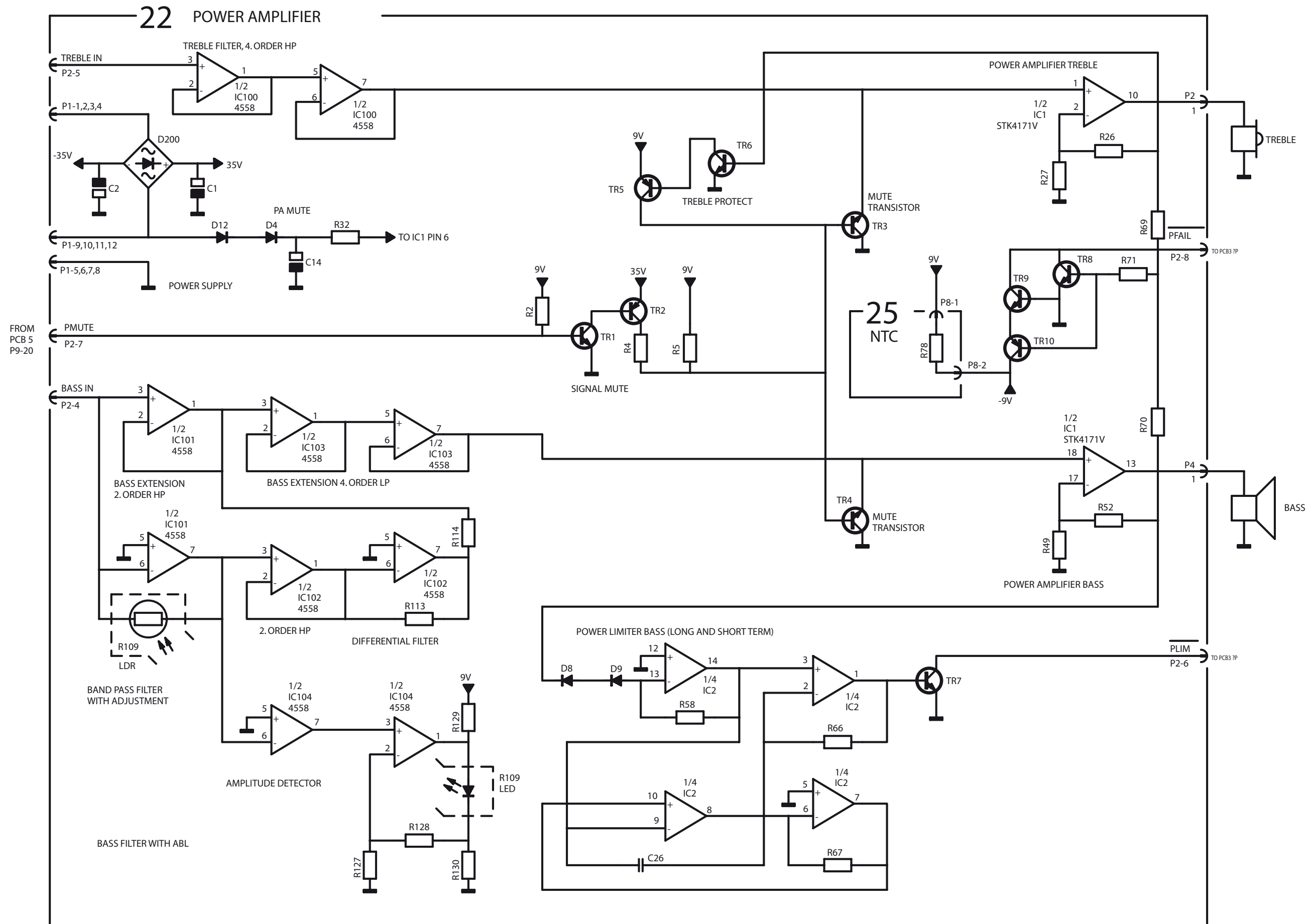

Available parts

| | | | | | |
|------|---------|--------------------|------|---------|------------------------|
| 9001 | 2576302 | Distance bolt | 9012 | 3332055 | Damper |
| 9002 | 3114422 | Chassis | 9013 | 3170300 | Insulating piece |
| 9003 | 8480340 | Tweeter | 9014 | 3152214 | Wire holder |
| 9004 | 3907064 | Rubber | 9015 | 6276907 | Mains socket |
| 9005 | 3950053 | Rubber belt | 9016 | 3164935 | Cover |
| 9006 | 3451207 | Front piece | 9017 | 3114406 | Chassis f. sockets |
| 9007 | 3169016 | Operating panel | 9018 | 8006108 | Rectifier PCB |
| 9008 | 3459454 | Cap, dark grey | 9019 | 3114422 | Chassis |
| | 3459108 | Cap, black | 9020 | 3451207 | Front piece |
| | 3459106 | Cap, grey | 9021 | 3451470 | Cloth front, dark grey |
| 9009 | 3430055 | Cabinet, dark grey | | 3451472 | Cloth front, silver |
| | 3430056 | Cabinet, black | | 3451244 | Cloth front, black |
| | 3430614 | Cabinet, grey | 9022 | 3031382 | Wall fittings |
| 9010 | 2816214 | Clips | 9023 | 3164920 | Cover f. wall fittings |
| 9011 | 8480259 | Woofer | | | |

02Module 8006073 Switch Mode Power Supply

19Module 8006107 DC/DC Converter
 2622423 Insulating piece
 2364066 Rivet
 2816195 Spring clips

20Module 8006091 Transformer left, type 1601, 1607, 1608
 8006092 Transformer left, type 1602, 1605
 8006093 Transformer left, type 1603
 8006094 Transformer left, type 1604

21Module 8006061 Transformer right, type 1601, 1607, 1608
 8006062 Transformer right, type 1602, 1605
 8006063 Transformer right, type 1603
 8006064 Transformer right, type 1604

22Module 8006087 Power Amplifier
 6200044 Band cable

25Module 8006109 NTC PCB

31Module 8002938 LF Supply and Control

32Module 8002935 Cross Field

34Module 8002932 Plug PCB

35Module 8002937 Display, Keyboard and IR Receiver

36Module 8002944 Microcomputer

Survey of screws and washers

| | | |
|----|---------|--------------------------|
| 1 | 2046032 | Allen screw, 6 x 32.7mm |
| 2 | 2816267 | Spring |
| 3 | 2622487 | Washer |
| 4 | 2013176 | Screw, 3 x 6mm |
| 5 | 2015154 | Screw, 3.5 x 25mm |
| 6 | 2013188 | Screw, 3 x 8mm |
| 7 | 2036082 | Screw, 2.5 x 8mm |
| 8 | 7530119 | Solder tag |
| 9 | 2640054 | Washer |
| 10 | 2011056 | Screw, 3 x 16mm |
| 11 | 2038111 | Screw, 3 x 8mm |
| 13 | 2622041 | Washer |
| 14 | 2624013 | Washer |
| 15 | 2013177 | Screw, 3 x 13mm |
| 16 | 2038103 | Screw, 3 x 12mm |
| 17 | 2622247 | Washer, 3.2 x 10.2 x 1mm |
| 18 | 3358305 | Heat sink |
| 19 | 2015167 | Screw, 3.5 x 14mm |
| 20 | 2625039 | Lock washer |
| 21 | 2011055 | Screw, 3 x 10mm |

Accessories

| | |
|---------|-------------------------------|
| 3031302 | Wall bracket, type 1607 |
| 3031235 | Wall bracket |
| 3390481 | Bag with parts f/Wall bracket |
| 3031333 | Wall plate |
| 3390468 | Bag with parts f/Wall plate |
| 1160611 | Table stand |
| 3390480 | Bag with parts f/table stand |
| 2560276 | Cable cover, 10 pieces |

Parts not shown

| | |
|---------|---------------------------|
| 3947547 | Foam, 3x19mm x 10m |
| 3947350 | Foam, 3x7mm x 10m |
| 3947548 | Foam, 6x7mm x 10m |
| 3984215 | Heat sink compound |
| 3040016 | Allen key, 4mm |
| 6100273 | Mainscable EU, type 1601 |
| 6100329 | Mainscable GB, type 1602 |
| 6100307 | Mainscable US, type 1603 |
| 6100247 | Mainscable JAP, type 1604 |
| 6100086 | Mainscable AUS, type 1605 |
| 6100386 | Mainscable KOR, type 1607 |
| 6100047 | Mainscable CHK, type 1608 |

Packing

| | |
|---------|--------------|
| 3392368 | Outer carton |
| 3397921 | Foam packing |
| 3946038 | Foam foil |

Survey of wire bundles

| | |
|---------|--|
| 6276906 | Wire bundle, left: 2P23 - 20P21 2P24 - 32P4 2P25 - 22P2 20P22 - 22P1 22P3 - Tweeter 22P4 - Woofer |
| 6276908 | Wire bundle, right: 31GND - Chassis 31P14 - 19P13 31P15 - 21P5 31P16 - 22P2 31P17 - 32P5 31P18 - 32P6 22P3 - Tweeter 22P4 - Woofer |
| 6200239 | Varnished tubing PCB set |
| 6276907 | Mains socket wire bundle |

Available documentation

See Retail Ordering System

Bang & Olufsen
DK-7600 Struer
Denmark

Phone +45 96 84 11 22*
Fax +45 97 85 39 11

06-06 A