

DA440PBT: 99900780: 19990119



**Model DA440PBT
PTO, Belt Driven
Topdeck Compressor**
(Previously Model 80 PTO, Blt Driven Topdeck)



IOWA MOLD TOOLING CO., INC.
BOX 189, 500 HWY 18 WEST, GARNER, IA 50438
TEL: 515-923-3711
TECHNICAL SUPPORT FAX: 515-923-2424
MANUAL PART NUMBER 99900780

PRECAUTIONS

Read before operating your compressor!



71393886



DANGER

**EXPLODING TANK WILL CAUSE
DEATH, SERIOUS INJURY
OR PROPERTY DAMAGE**

- Drain air tank after each use to prevent moisture build-up and corrosion which leads to tank failure.
- Assure that tank and compressor relief valves work properly, and are at correct pressure settings.
- **DO NOT** modify or repair air tank.
- **NEVER** drive vehicle with pressure in air tank.

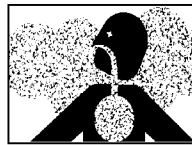

Failure to follow operating and maintenance procedures as outlined in this manual could result in equipment damage, personal injury or death. Follow all maintenance procedures and intervals.



Do not use air from this compressor for breathing or food processing. Air from this compressor will cause severe injury or death if used for breathing or food processing.



Maintenance must be performed only by trained and qualified personnel, using correct tools, specified torques and approved replacement parts.

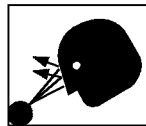

Hot oil under pressure can cause severe injury or death. Shut down, let cool and relieve pressure in compressor before servicing.



All electrical components and cable wiring must be installed and grounded in accordance with NFPA, national electrical codes and applicable state and local codes.



Do not overfill the compressor with oil. Use correct quantity of manufacturer's lubricant. Repair leaks and clean spills immediately.



Before removing guards or servicing the compressor, disconnect all power supplies. Display warning signs and lock out electrical circuits.



Compressors generate high temperatures. Do not touch or otherwise come in contact with hot surfaces. Doing so can cause severe personal injury.



All guards must be in position and secure before and during operation.

TABLE OF CONTENTS

PARA	TITLE	PAGE
	SPARE PARTS LIST	iv
 Section 1. INTRODUCTION		
1-1.	GENERAL INFORMATION	1-11-
2.	ORDERING INFORMATION	1-1
 Section 2. INSTALLATION		
2-1.	GENERAL	2-1
2-2.	PTO INSTALLATION	2-1
2-3.	UNDER-DECK COMPRESSOR INSTALLATION	2-1
 Section 3. OPERATION		
3-1.	OPERATION	3-1
3-2.	SYSTEM SHUTDOWN	3-1
 Section 4. PREVENTIVE MAINTENANCE		
4-1.	PREVENTIVE MAINTENANCE	4-1
4-2.	LUBRICATION	4-1
4-3.	PREVENTIVE MAINTENANCE CHECKLIST	4-1
 Section 5. PARTS		
5-1.	COMPRESSOR PARTS	5-1
 Section 6. REFERENCE		

LIST OF ILLUSTRATIONS

FIGURE	TITLE (PART NUMBER)	PAGE
D-1.	TABLE - PREVENTIVE MAINTENANCE CHECKLIST	4-1
	DA440PBT COMPRESSOR-RH, 3/4 TON SGL WHEEL (23000146-1)	5-1
	DA440PBT COMPRESSOR-RH, 3/4 TON SGL WHEEL (23000146-2)	5-2
	INSTALLATION HARDWARE-RH, 3/4 TON, SGL WHEEL	5-3
	DA440PBT COMPRESSOR-LH, 1 TON DUAL WHEEL (23000147-1)	5-4
	DA440PBT COMPRESSOR-LH, 1 TON DUAL WHEEL (23000147-2)	5-5
	DA440PBU COMPRESSOR-CW TRANSMISSION (23000952-1)	5-6
	DA440PBU COMPRESSOR-CW TRANSMISSION (23000952-2)	5-7
F-1.	TORQUE DATA CHART	6-1
F-2.	TIRE LOAD AND INFLATION PRESSURES	6-2

RECOMMENDED SPARE PARTS LIST

1 Year Supply

DA440PBT PTO, BELT DRIVEN TOPDECK COMPRESSOR

For Manual: 99900780

This spare parts list does not necessarily indicate that the items can be expected to fail in the course of a year. It is intended to provide the user with a stock of parts sufficient to keep the unit operating with minimal down-time waiting for parts. There may be parts failures not covered by this list. Parts not listed are considered as not being Critical or Normal Wear items during the first year of operations and you need to contact the distributor or manufacturer for availability.

ASSEMBLY DESIGNATION	ITEM NO.	PART NO.	DESCRIPTION	QTY	CODE	SHELF LIFE (MO)	ORDER QTY
23000146.01.19970624			RH, 3/4 TON, SINGLE WHEEL COMPRESSOR				
	5	60111268	SHAFT-BELT 18"	1	W		
	6	60118327	SHAFT-BELT 15"	1	W		
	8	70580116	BELT-BP70	2	C		
	9	70580115	BELT-BP33	2	C		
	12	70055062	BEARING-PILLOW BLOCK	4	C		
	24	77041008	PRESSURE SWITCH	1	C		
	31	70048069	AIR FILTER	1	P		
	32	73054031	UNLOADER VALVE	1	C		
23000147.01.19961014			LH, 1 TON, DUAL WHEEL COMPRESSOR				
	4	70055062	BEARING-PILLOW BLOCK	2	C		
	5	70580126	BELT B84	2	C		
	6	60120068	SHAFT	1	W		
	14	77041008	PRESSURE SWITCH	1	C		
	18	70048069	AIR FILTER	1	P		
	21	73054031	UNLOADER VALVE	1	C		
COMPRESSOR (R30)-70073051							
	REF	70073727	LP INTAKE VALVE	1	W		
	REF	70073726	LP EXHAUST VALVE	1	W		
	REF	70732447	HP INTAKE VALVE	1	W		
	REF	73054340	HP EXHAUST VALVE	1	W		
	REF	70073766	RING SET	1	W		
	REF	70143298	RELEASE VALVE KIT	1	W		
	REF	70732429	INTERCOOLER TUBE LH	1	W		
	REF	70732430	INTERCOOLER TUBE RH	1	W		
	REF	70732448	AIR FILTERS	1	P		
	REF	76391490	SHAFT SEAL	1	W		
	REF	73054339	POP OFF 70PSI	1	W		
	REF	73054031	PILOT VALVE	1	C		

SECTION 1. GENERAL INFORMATION

1-1. INTRODUCTION

This manual provides information on the installation, operation and repair of the IMT DA440PBt PTO, belt driven topdeck compressor.

Three means are used throughout this manual to gain the attention of operating and service personnel. They are NOTES, CAUTIONS and WARNINGS and are defined as follows:

NOTE

A NOTE IS USED TO EITHER CONVEY ADDITIONAL INFORMATION OR TO PROVIDE FURTHER EMPHASIS FOR A PREVIOUS POINT.

CAUTION

A CAUTION IS USED WHEN THERE IS THE STRONG POSSIBILITY OF DAMAGE TO THE EQUIPMENT OR PREMATURE EQUIPMENT FAILURE.

WARNING

A WARNING IS USED WHEN THERE IS THE POTENTIAL FOR PERSONAL INJURY OR DEATH.

Operate this equipment with respect and service it regularly. These two things can add up to a safer working environment and longer equipment life.

1-2. ORDERING INFORMATION

When placing orders or requesting assistance, refer to the information below:

TO BE COMPLETED BY DEALER	
CHASSIS INFORMATION	
TRANSMISSION MAKE:	MODEL:
PTO NUMBER:	PTO %:
COMPRESSOR AND HYDRAULIC PUMP INFORMATION	
COMPRESSOR MODEL:	SERIAL NUMBER:
PUMP MAKE:	MODEL:
RESERVOIR CAPACITY:	ENGINE RPM:

SECTION 2. INSTALLATION

2-1. GENERAL

This section deals with the installation of the PTO. The instructions are intended as a guide to assist you with your particular installation. We can not cover every make, model and year of truck manufactured world-wide, so these instructions will provide only general information. Use this information as a guide only.

2-2. PTO INSTALLATION

Power take-off manufacturers provide specific installation instructions for their products. Those instructions should be followed when installing a PTO. Some trucks may require modification of the transmission cross-member to provide clearance and the exhaust pipe may need modification. Check with the PTO manufacturer's representative for specific instructions regarding your particular make, model and year of vehicle. The following instructions are a guide in this application.

1. If the vehicle is new, drain the transmission oil into a clean container for reuse. If the vehicle is used, drain and dispose of the transmission oil.
2. Temporarily install the PTO with the proper gaskets and only two studs. Snug the PTO down and check the backlash for maximum allowance of 1/32" to 1/16". If the backlash is excessive, remove gaskets and check backlash again until it is corrected.
3. Remove the PTO and apply Permatex to the gaskets. If the holes for the studs are tapped through the transmission housing, apply Permatex to the studs and tighten them down. Make certain that the studs do not interfere with the transmission gears.

CAUTION

AVOID CONTACT OF PERMATEx WITH AUTOMATIC TRANSMISSION FLUID.

4. Install the PTO and gaskets. Torque the nuts to 30 - 35 ft-lbs (4.14 - 4.84 kg-m) for a 6-bolt PTO and 45 - 50 ft-lbs (6.22 - 6.91 kg-m) for 8-bolt PTO's. Recheck the backlash.
5. Install the shifter cable to suit conditions. Always allow for a slight overshift on lever or knob to ensure the PTO is fully disengaged.

CAUTION

IT IS IMPORTANT THAT ADEQUATE SPACE BE ALLOWED FOR FULL ENGAGEMENT OF THE PTO. MODIFY THE EXHAUST OR OTHER OBSTRUCTIONS AS NEEDED.

CAUTION

AVOID SHARP BENDS IN THE SHIFTER CABLE. ALL BENDS SHOULD HAVE AT LEAST A 6" RADIUS. TIGHTER BENDS WILL CAUSE DIFFICULT OPERATION OF THE SHIFTER KNOB.

6. Replace the transmission oil. If the PTO is located below the transmission oil level, an additional quantity of oil will be required.
7. Start the engine, engage the PTO and allow it to run for 5 - 10 minutes. Check for leaks, unusual noise and proper operation.
8. Retorque the mounting bolts.

WARNING

THE INSTALLER OF THE DRIVELINE MUST INSPECT THE FINAL POSITION OF THE DRIVELINE TO DETERMINE WHETHER ITS LOCATION PROVIDES SUFFICIENT PROTECTION TO AN OPERATOR, OR OTHER PERSONNEL, FROM HAZARDS ASSOCIATED WITH A ROTATING DRIVELINE. IF PROTECTION IS INSUFFICIENT, THE INSTALLATION OF A GUARD IS REQUIRED. IF YOU ARE UNSURE OF METHODS TO GUARD A ROTATING DRIVELINE, CALL IOWA MOLD TOOLING CO., INC. FOR INSTRUCTIONS. FAILURE TO DO SO MAY RESULT IN SERIOUS INJURY OR DEATH.

DANGER



CONTACT WITH A ROTATING DRIVELINE
WILL CAUSE
DEATH OR SERIOUS INJURY
KEEP AWAY

- Keep clear of rotating drive shaft.
- Never work on or near an installed power take-off or driveline with the engine running.

70392891

2-3. TOP-DECK COMPRESSOR INSTALLATION

Due to the large variety of carrier vehicles, the instructions in this paragraph should be used as a guide only. Refer to Figure E-2 for reference.

1. Position the compressor across the frame of the truck in the desired location. The location selected should provide adequate ventilation while at the same time affording access to the compressor.
2. Lift the compressor base into position. Check for belt clearance and approximate drive shaft length.
3. Using the base as a template, drill four 17/32" diameter holes. The 3/4-ton/RH will be drilled through the top of frame rails. The 1-ton/LH will be drilled through the sides of the frame rails.
4. On the 3/4-ton/LH, insert spacers between base and frame rails. No spacers are used with the 1-ton/RH. Bolt the compressor base to the frame of the truck using the 1/2" hardware.
5. Using the appropriate driveshaft with knuckles in place, measure the exact length required, cut off excess shaft and weld in place (1/4" weld all around).
6. Install the driveshaft to the PTO and the compressor, tighten the lock bolts and tie-wire in place.
7. Tighten all bolts per Torque Data Chart.
8. Connect the 3/4" air hose from the compressor to the air tank.
9. Install the engine speed control and connect the hoses from compressor to speed control.

SECTION 3. OPERATION

3-1. OPERATION

This section deals with the proper methods of system operation and shutdown. These procedures should be followed to prevent damage and ensure efficient operation.

Start the compressor as follows:

1. Ensure the PTO is disengaged and the receiver drain cock is open.
2. Start the truck engine and allow it to idle until it reaches the proper operating temperature (refer to the Owner's Manual).
3. Depress the clutch, engage the PTO and carefully release the clutch pedal.
4. Activate the engine speed control by closing the receiver drain cock. The compressor is now operating and supplying working air.

NOTE

WHEN STARTING THE COMPRESSOR, THE RPM'S WILL AUTOMATICALLY INCREASE DUE TO LOW VOLUME OF AIR IN THE SYSTEM

CAUTION

1000 RPM MAX.

Operating this unit in excess of 1000 RPM, measured at the compressor flywheel, will void your warranty. Engine RPM may be different.

3-2. SYSTEM SHUTDOWN

System shutdown is accomplished as follows:

1. Allow the compressor to build to maximum pressure and the truck engine will automatically idle down.
2. Place the compressor control valve in the open (off) position.
3. Depress the clutch pedal and disengage the PTO.
4. Open the receiver drain cock and discharge the air in the receiver.

WARNING

FEDERAL LAW PROHIBITS DRIVING THE CARRIER VEHICLE ON PUBLIC ROADS WITH THE RECEIVER FILLED WITH COMPRESSED AIR. ALWAYS DRAIN THE RECEIVER BEFORE MOVING THE VEHICLE.

Section 4. PREVENTIVE MAINTENANCE

4-1. PREVENTIVE MAINTENANCE

Proper maintenance on a regular schedule is essential to keep your unit operating efficiently. Proper maintenance procedures and required service intervals are outlined in this section. Personnel responsible for unit upkeep should become familiar with frequency and type of maintenance required and perform these tasks at recommended intervals.

4-2. LUBRICATION

The only lubrication required is on the carrier vehicle and the compressor itself. Refer to the appropriate Owner's Manual for information on the truck and compressor for the type and frequency of lubrication required.

CAUTION

USE ONLY A 30W NON-DETERGENT OIL IN THE COMPRESSOR. DO NOT USE A SYNTHETIC OIL.

4-3. PREVENTIVE MAINTENANCE CHECKLIST

The checklist (Figure A) is designed to assist you in keeping your unit in efficient operating condition. Items in this section apply to the unit only. The carrier vehicle should also be inspected regularly (refer to the carrier vehicle's service manual).

ITEM	DESCRIPTION	INTERVAL						
		DAILY	WEEKLY	EVERY 200 HRS	HOURS/MONTHS			
					500/3	1000/6	1500/9	2000/12
COMPRESSOR	AIR INTAKE - INSPECT AND CLEAN							
	FRAME OIL LEVEL - CHECK							
	FRAME OIL - CHANGE							
	VALVES - INSPECT AND CLEAN							
	INTER COOLER - CLEAN EXTERIOR							
	LOW OIL LEVEL SWITCH - CHECK							
	OPERATE SAFETY VALVES CLEAN SAFETY VALVES							
V-BELT DRIVE	BELT TENSION - CHECK							
RECEIVER	DRAIN CONDENSATION - MANUAL OPERATE SAFETY VALVES							
GENERAL	CHECK AND TIGHTEN ALL BOLTS							
	CHECK ALL ELECT. CONNECTIONS							
	CHECK LUBRICATION							

FIGURE A. PREVENTIVE MAINTENANCE CHECKLIST

SECTION 5. PARTS

5-1. COMPRESSOR PARTS

This section contains the exploded parts drawings with accompanying parts lists for associated assemblies. These drawings are intended to be used in conjunction with the instructions found elsewhere in this manual. For information pertaining to the compressor, refer to its specific manual.

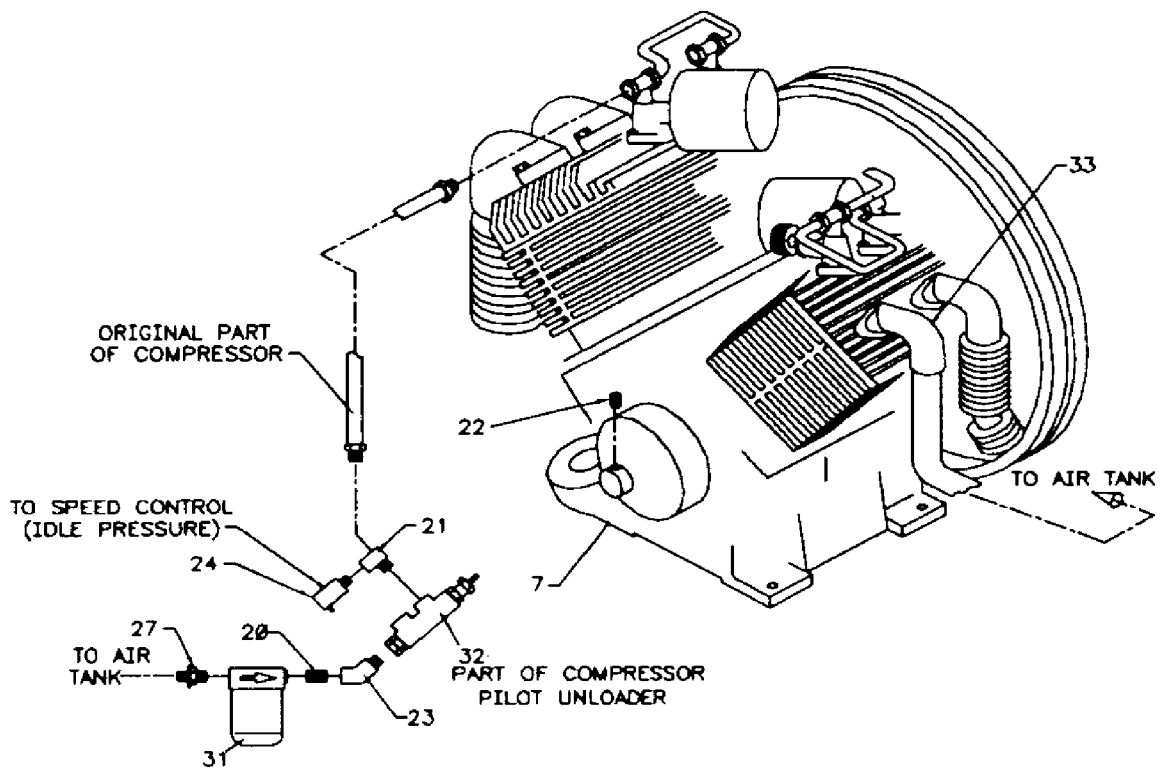

ITEM	PART NO.	DESCRIPTION	QTY	ITEM	PART NO.	DESCRIPTION	QTY
1.	52712404	BASE WELDMENT	1	17.	72062007	NUT 3/4-10 HEX	2
2.	52712567	BEARING BRACKET	1	18.	72062080	NUT 1/2-13 LOCK	16
3.	52706205	TIGHTENER BOLT 4"	2	19.	72063005	WASHER 1/2 WRT	12
4.	52704923	SCREW-BELT TIGHTENER	1	20.	72053013	PIPE NIPPLE 1/4NPT X CLOSE	1
5.	60111268	SHAFT-BELT 18"	1	21.	72532013	STREET TEE 1/4NPT BRS	1
6.	60118327	SHAFT-BELT 15"	1	22.	72053411	PIPE PLUG 1/8NPT SQHD	1
7.	70073051	COMPRESSOR-R30	1	23.	72053533	STREET ELBOW 1/4NPT 45°	1
8.	70580116	BELT-BP70 GATES 9003-2070	2	24.	77041008	PRESSURE SWITCH	1
9.	70580115	BELT-BP33 GATES 9003-2033	2	27.	72532552	HOSE FITTING 1/4 1/4	1
10.	70056272	PULLEY	2	28.	72532974	STREET ELBOW 1/4NPT 90° SHT	1
11.	70056388	SHEAVE 4" 2-GROOVE	1	29.	72601430	CARR BOLT 3/8-16X2 SQNK GR2	4
12.	70055062	BEARING-PILLOW BLOCK	4	31.	70048069	AIR FILTER	1
13.	70143234	BUSHING	1	32.	73054031	UNLOADER VALVE	1REF
14.	72060957	CARR BOLT 1/2-13X2 SQNK GR2	4	33.	72053245	PIPE PLUG 1/4NPT	1
15.	72060094	CAP SCR 1/2-13X1-3/4 HHGR5	4	34.	70056116	BUSHING-SPLIT TAPER	2
16.	72060095	CAP SCR 1/2-13X2 HHGR5	4	35.	72035361	GREASE ZERK 1/8NPT 90°	2

DA440PBT COMPRESSOR-RH, 3/4 TON, SINGLE WHEEL (23000146-1)

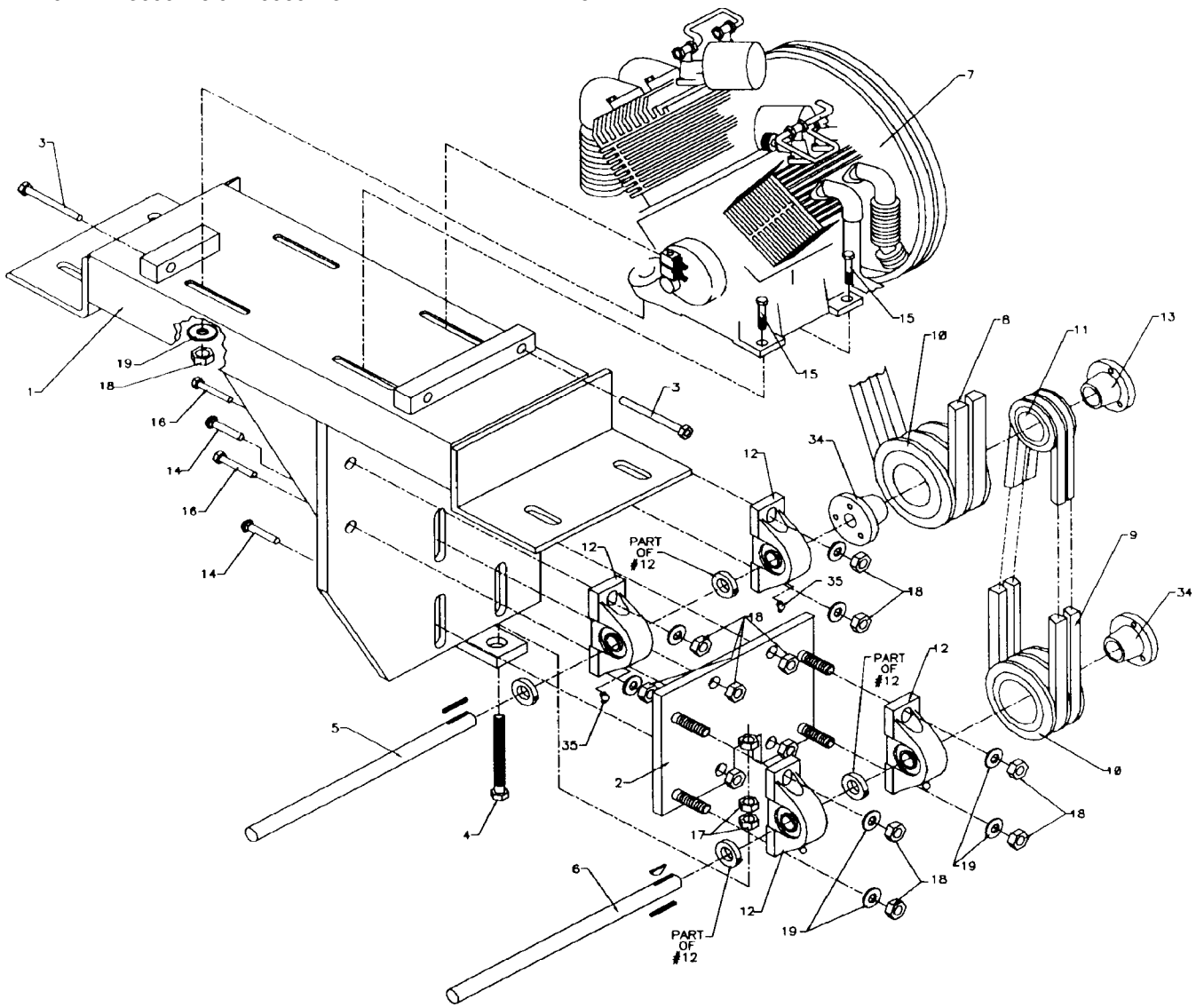

DA440PBT COMPRESSOR-RH, 3/4 TON, SINGLE WHEEL (23000146-2)

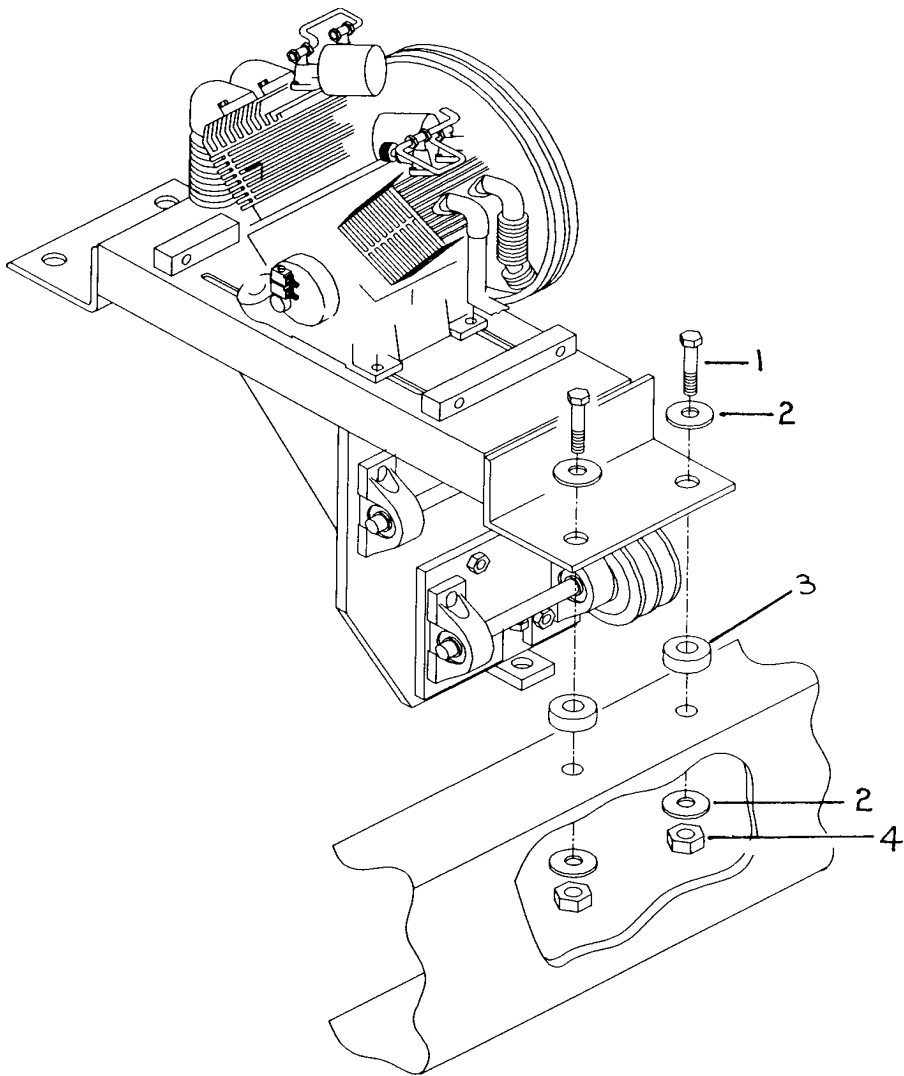

ITEM	PART NO.	DESCRIPTION	QTY
1.	72060095	CAP SCR 1/2-13X3 HHGR5	4
2.	72063005	WASHER 1/2 WRT	8
3.	60113720	SPACER	4
4.	72062080	NUT 1/2 LOCK	4

INSTALLATION HARDWARE-RH, 3/4 TON, SINGLE WHEEL

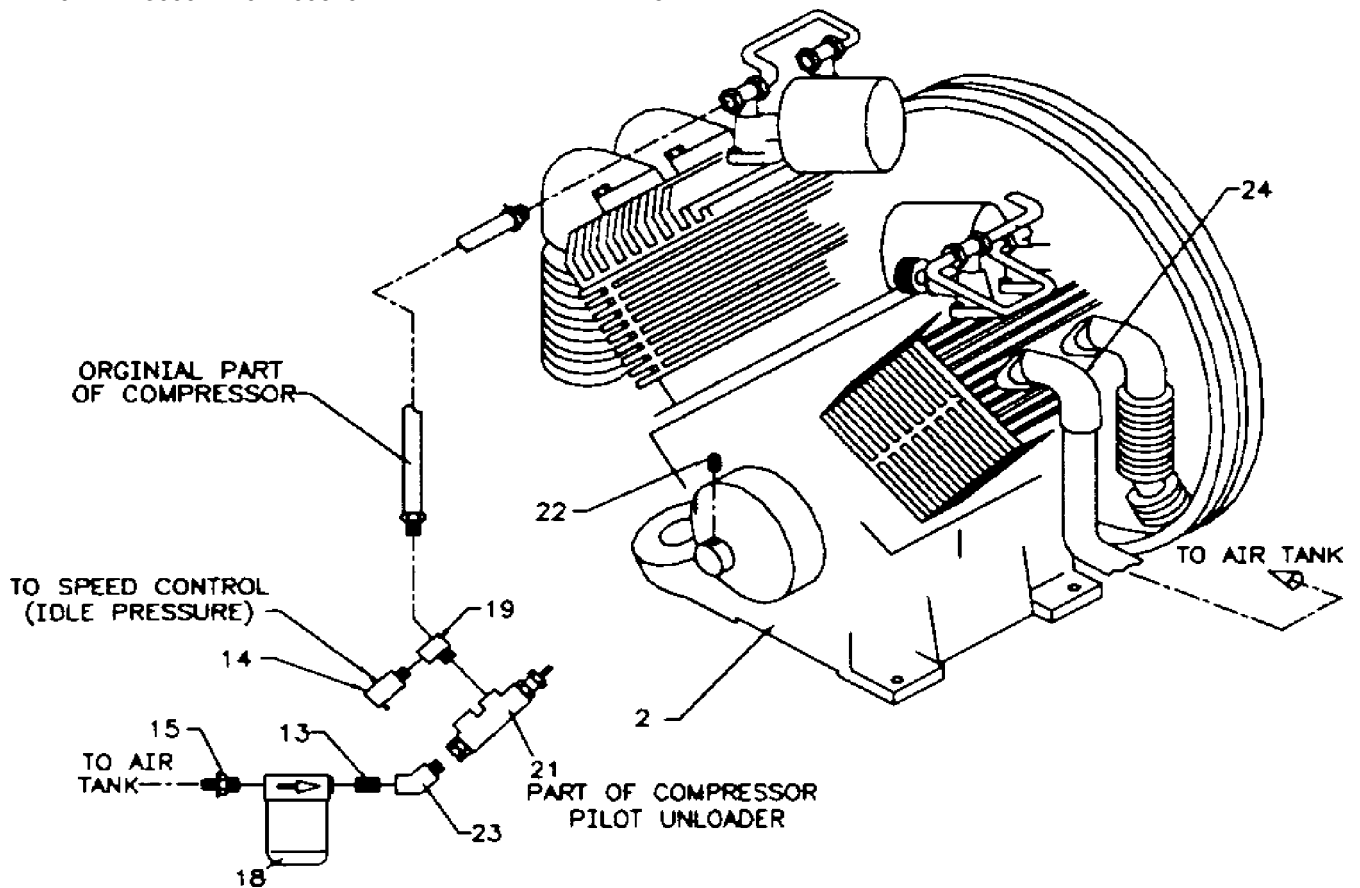

ITEM	PART NO.	DESCRIPTION	QTY	ITEM	PART NO.	DESCRIPTION	QTY
1.	52713749	FRAME WELDMENT-LH	1	14.	77041008	PRESSURE SWITCH	1
2.	70073051	COMPRESSOR	1	15.	72532552	HOSE FITTING 1/4 1/4	1
3.	52706205	TIGHTENER BOLT 4"	2	18.	70048069	AIR FILTER	1
4.	70055062	BEARING-PILLOW BLOCK	2	19.	72532013	STREET TEE 1/4NPT BRS	1
5.	70580126	BELT-B84 GATES 9093-2083	2	21.	73054031	UNLOADER VALVE	1REF
6.	60120068	SHAFT 1-1/4 X 10-1/4	1	22.	72053411	PIPE PLUG 1/8NPT SQHD	1
7.	70056111	BUSHING	1	23.	72053533	STREET ELBOW 1/4NPT 45°	1
8.	70056523	PULLEY DUAL GROOVE 9"	1	24.	72053245	PIPE PLUG 1/4NPT	1
9.	72060102	CAP SCR 1/2-13X5-1/2 HHGR5	2	25.	72060093	CAP SCR 1/2-13X1-1/2 HHGR5	4
10.	72062080	NUT 1/2-13 LOCK	4	26.	72063005	WASHER 1/2 WRT	4
11.	72063005	WASHER 1/2 WRT	4	27.	72062080	NUT 1/2-13 LOCK	4
12.	72532974	STREET ELBOW 1/4NPT 90° SHT	1	28.	72060108	CAP SCR 1/2-13X6 HHGR5	2
13.	72053013	PIPE NIPPLE 1/4NPT X CLOSE	1	29.	60118856	SUPPORT	1

DA440PBT COMPRESSOR-LH, 1 TON, DUAL WHEEL (23000147-1)

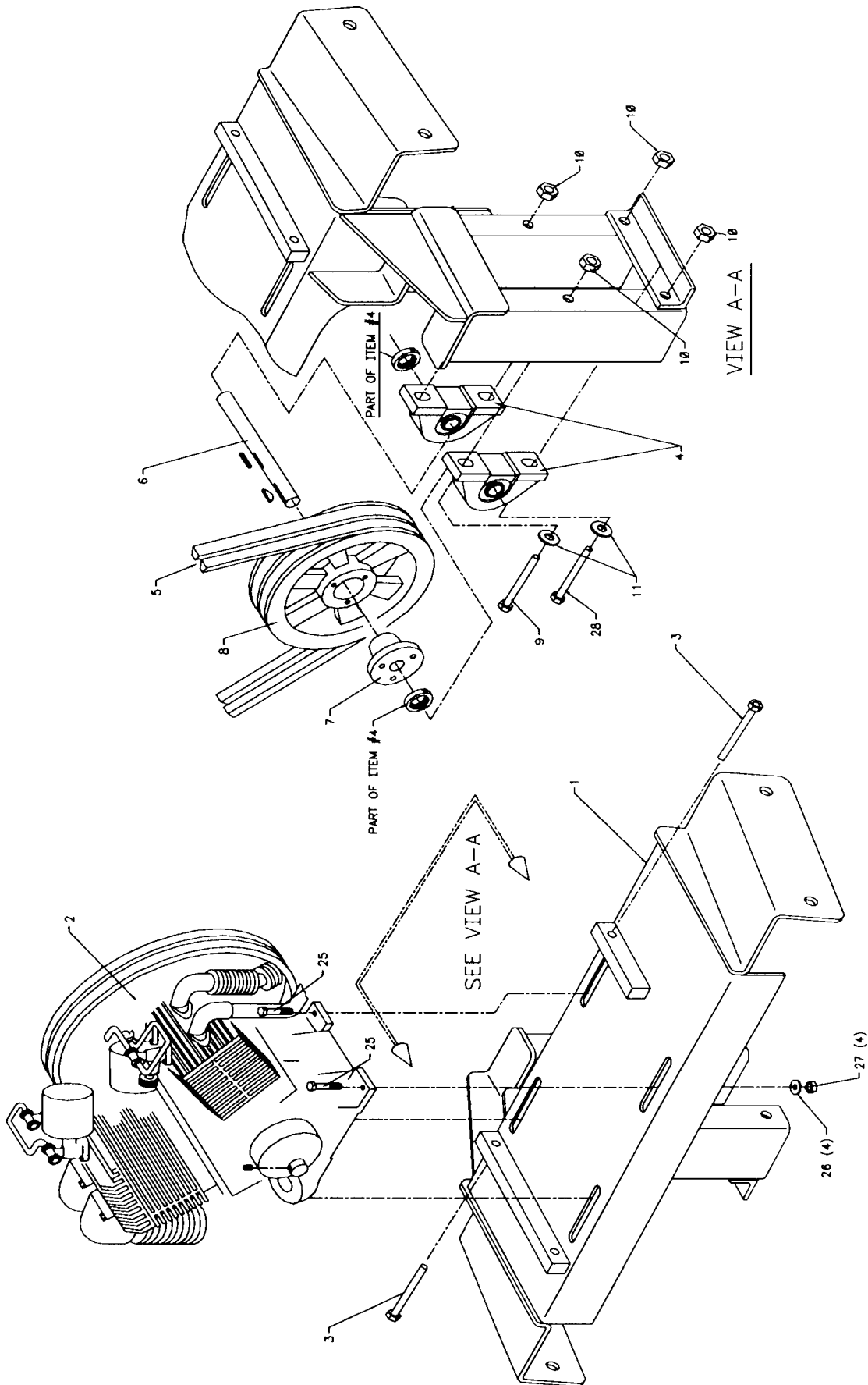





DA440PBT COMPRESSOR-LH, 1 TON, DUAL WHEEL (23000147-2)

SECTION 6. REFERENCE

TORQUE DATA CHART - DOMESTIC

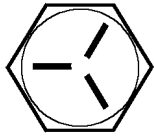
FINE THREAD BOLTS

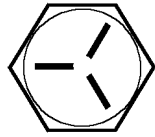
COARSE THREAD BOLTS

SIZE (DIA-TPI)	BOLT DIA (INCHES)	TIGHTENING TORQUE				SIZE (DIA-TPI)	BOLT DIA (INCHES)	TIGHTENING TORQUE			
											
		SAE J429 GRADE 5		SAE J429 GRADE 8				SAE J429 GRADE 5		SAE J429 GRADE 8	
		PLAIN (FT-LB)	PLATED (FT-LB)	PLAIN (FT-LB)	PLATED (FT-LB)			PLAIN (FT-LB)	PLATED (FT-LB)	PLAIN (FT-LB)	PLATED (FT-LB)
5/16-24	0.3125	19	14	27	20	5/16-18	0.3125	17	13	25	18
3/8-24	0.3750	35	26	49	35	3/8-16	0.3750	31	23	44	33
7/16-20	0.4375	55	41	78	58	7/16-14	0.4375	49	37	70	52
1/2-20	0.5000	90	64	120	90	1/2-13	0.5000	75	57	105	80
9/16-18	0.5625	120	90	170	130	9/16-12	0.5625	110	82	155	115
5/8-18	0.6250	170	130	240	180	5/8-11	0.6250	150	115	220	160
3/4-16	0.7500	300	225	420	315	3/4-10	0.7500	265	200	375	280
7/8-11	0.8750	445	325	670	500	7/8-9	0.8750	395	295	605	455
1-12	1.0000	645	485	995	745	1-8	1.0000	590	445	910	680
1 1/8-12	1.1250	890	670	1445	1085	1 1/8-7	1.1250	795	595	1290	965
1 1/4-12	1.2500	1240	930	2010	1510	1 1/4-7	1.2500	1120	840	1815	1360
1-3/8-12	1.3750	1675	1255	2710	2035	1-3/8-6	1.3750	1470	1100	2380	1780
1 1/2-12	1.5000	2195	1645	3560	2670	1 1/2-6	1.5000	1950	1460	3160	2370

When using the torque data in the charts above, the following rules should be observed.

1. Bolt manufacturer's particular specifications should be consulted when provided.
2. Flat washers of equal strength must be used.
3. All torque measurements are given in foot-pounds. To convert to inch-pounds, multiply by 12.
4. Torque values specified are for bolts with residual oils or no special lubricants applied. If special lubricants of high stress ability, such as Never-Seez compound graphite and oil, molybdenum disulphite, colloidal copper or white lead are applied, multiply the torque values in the charts by the factor .90. The use of Loctite does not affect the torque values listed above.
5. Torque values for socket-head capscrews are the same as for Grade 8 capscrews.

FIGURE F-1. TORQUE DATA CHART

SINGLE TIRES FOR TRUCKS IN HIGHWAY SERVICE												
TIRE SIZE	LOAD RANGE	TIRE LOAD LIMITS AT VARIOUS INFLATION PRESSURES										
		50	55	60	65	70	75	80	85	90	95	100
7.00-20	D	2100	2260	2390	2530	2670	2790					
7.00-20	E	2100	2260	2390	2530	2670	2920	3030	3150			
7.50-20	D	2360	2530	2680	2840	2990	3140					
7.50-20	E	2360	2530	2680	2840	2990	3140	3270	3410	3530		
8.25-20	E	2800	3010	3190	3370	3560	3730	3890	4050			
8.25-20	F	2800	3010	3190	3370	3560	3730	3890	4050	4210	4350	4500
9.00-20	E		3560	3770	4000	4210	4410	4610				
9.00-20	F		3560	3770	4000	4210	4410	4610	4790	4970	5150	
10.00-20	F			4290	4530	4770	4990	5220	5430			
10.00-20	G			4290	4530	4770	4990	5220	5430	5640	5840	6040
11.00-20	F			4670	4940	5200	5450	5690	5920			
11.00-20	G			4670	4940	5200	5450	5690	5920	6140	6370	6590
11.00-22	F			4960	5240	5520	5790	6040	6290			
11.00-22	G			4960	5240	5520	5790	6040	6290	6530	6770	7000

DUAL TIRE FOR TRUCKS IN HIGHWAY SERVICE												
TIRE SIZE	LOAD RANGE	TIRE LOAD LIMITS AT VARIOUS INFLATION PRESSURES										
		40	45	50	55	60	65	70	75	80	85	90
7.00-20	D	1840	1980	2100	2220	2340	2450					
7.00-20	E	1840	1980	2100	2220	2340	2450	2560	2660	2760		
7.50-20	D	2070	2220	2350	2490	2620	2750					
7.50-20	E	2070	2220	2350	2490	2620	2750	2870	2990	3100		
8.25-20	E	2460	2640	2800	2960	3120	3270	3410	3550			
8.25-20	F	2460	2640	2800	2960	3120	3270	3410	3550	3690	3820	3950
9.00-20	E		3120	3310	3510	3690	3870	4040				
9.00-20	F		3120	3310	3510	3690	3870	4040	4200	4360	5420	
10.00-20	F			3760	3970	4180	4380	4580	4760			
10.00-20	G			3760	3970	4180	4380	4580	4760	4950	5120	5300
11.00-20	F			4100	4330	4560	4780	4990	5190			
11.00-20	G			4100	4330	4560	4780	4990	5190	5390	5590	5780
11.00-22	F			4350	4600	4840	5080	5300	5520			
11.00-22	G			4350	4600	4840	5080	5300	5520	5730	5940	6140

DEFINITE TIRE INFLATION PRESSURES ARE ESTABLISHED FOR EACH TIRE SIZE DEPENDING UPON THE LOAD IMPOSED ON THE TIRE. FOR GREATER STABILITY, RIDING COMFORT AND PROLONGED TIRE LIFE, TIRES SHOULD BE INFLATED FOR THE LOADS CARRIED. THE "LOAD AND INFLATION TABLE" SHOWN ABOVE, INDICATES THE PROPER INFLATION PRESSURES.

TIRE AND RIM ASSOCIATION STANDARD TIRE LOADS AT VARIOUS INFLATION PRESSURES. LOAD RANGE LETTERS AND CORRESPONDING PLY RATING (D=8 PLY, E=10 PLY, F=12 PLY AND G=14 PLY).

FIGURE F-2. TIRE LOAD AND INFLATION PRESSURES

DA440PBT:99900780:

The information within this manual has been compiled and checked but errors do occur. To provide our customers with a method of communicating those errors we have provided the Manual Change Request form below. In addition to error reporting, you are encouraged to suggest changes or additions to the manual which would be of benefit to you. We cannot guarantee that these additions will be made but we do promise to consider them. When completing the form, please write or print clearly. Submit a copy of the completed form to the address listed below.

MANUAL CHANGE REQUEST

DATE	PRODUCT MANUAL	MANUAL PART NO.
SUBMITTED BY		
COMPANY		
ADDRESS		
CITY, STATE, ZIP		
TELEPHONE		

ERROR FOUND

LOCATION OF ERROR (page no.): _____

DESCRIPTION OF ERROR: _____

REQUEST FOR ADDITION TO MANUAL

DESCRIPTION OF ADDITION: _____

REASON FOR ADDITION: _____

MAIL TO: IOWA MOLD TOOLING Co., Inc.
Box 189,
Garner IA 50438-0189
ATTN: Technical Publications

LIMITED WARRANTY

WARRANTY COVERAGE - Products manufactured by Iowa Mold Tooling Co., Inc. (IMT) are warranted to be free from defects in material and workmanship, under proper use, application and maintenance in accordance with IMT's written recommendations, instructions and specifications as follows:

1. Ninety (90) days; labor on IMT workmanship from the date of shipment to the end user.
2. One (1) year; original IMT parts from the date of shipment to the end user.

IMT's obligation under this warranty is limited to, and the sole remedy for any such defect shall be the repair or replacement (at IMT's option) of unaltered parts returned to IMT, freight prepaid, and proven to have such defect, provided such defect occurs within the above stated warranty period and is reported within fourteen (14) days of its occurrence.

IMPLIED WARRANTY EXCLUDED - This is the only authorized IMT warranty and is in lieu of all other express or implied warranties or representations, including any implied warranties of merchantability or fitness for any particular purpose or of any other obligations on the part of IMT.

ITEMS EXCLUDED - The manufacturer gives no warranty on any components purchased by the manufacturer, and such components as are covered only by the warranties of their respective manufacturers.

WARRANTY CLAIMS - Warranty claims must be submitted and shall be processed in accordance with IMT's established warranty claim procedure.

WARRANTY SERVICE - Warranty service will be performed by any IMT distributor authorized to sell new IMT products of the type involved or by any IMT Service Center authorized to service the type of product involved or by IMT in the event of direct sales made by IMT. At the time of requesting warranty service, the purchaser must present evidence of the date of delivery of the product. The purchaser shall pay any premium for overtime labor requested by the purchaser, any charge for making service calls and for transporting the equipment to the place where warranty work is performed.

WARRANTY VOIDED - All obligations of IMT under this warranty shall be terminated:(1) if service other than normal maintenance or normal replacement of service items is performed by someone other than an authorized IMT dealer, (2) if product is modified or altered in ways not approved by IMT.

PURCHASER'S RESPONSIBILITY - This warranty covers only defective material and workmanship. It does not cover depreciation or damage caused by normal wear, accident, improper protection in storage, or improper use. The purchaser has the obligation of performing the care and maintenance duties discussed in IMT's written recommendations, instructions and specifications. Any damage which results because of purchaser's failure to perform such duties shall not be covered by this warranty. The cost of normal maintenance and normal replacement of service items such as filters, belts, etc. shall be paid by the purchaser.

CONSEQUENTIAL DAMAGES - The only remedies the purchaser has in connection with the breach or performance of any warranty on IMT products are those set forth above. In no event will the dealer, IMT or any company affiliated with IMT, be liable for business interruptions, loss of sales and/or profits, rental or substitute equipment, costs of delay or for any other special, indirect, incidental or consequential losses, costs or damages.

REPRESENTATIONS EXCLUDED - IMT products are subject to no expressed, implied or statutory warranty other than herein set forth, and no agent, representative or distributor of the manufacturer has any authority to alter the terms of this warranty in any way whatsoever or to make any representations or promises, express or implied, as to the quality or performance of IMT products other than those set forth above.

CHANGE IN DESIGN - IMT reserves the right to make changes in design or improvements upon its products without imposing any obligation upon itself to install the same upon its products theretofore manufactured.

Effective January, 1985

This parts manual is provided to the user to assist in servicing the equipment. It is the property of Iowa Mold Tooling Co., Inc and, as such, may not be reproduced either whole or in part, whether by chemical, electrostatic, mechanical or photographic means without the expressed written permission of an officer of Iowa Mold Tooling Co., Inc. One manual is provided with each piece of new equipment and additional manuals may be obtained at a nominal price.



IOWA MOLD TOOLING CO., INC.
BOX 189, GARNER, IA 50438-0189
TEL: 515-923-3711
TECHNICAL SUPPORT FAX: 515-923-2424