

CONTENTS

Introduction	1
Special Information	1
Maintenance	2
Disassembly	3
Assembly	5
Pressure Relief Valve Instructions	5

INTRODUCTION

The illustrations used in this maintenance bulletin are for identification purposes only and *should not be used for ordering parts*. Secure a parts list from the factory or a Viking representative. Always give complete name of part, part number and material with the model and serial number of the pump when ordering repair parts.

UNMOUNTED PUMP		UNITS
PACKED	MECH. SEAL	
C32	C432	Units are designed by the un-mounted pump model numbers followed by a letter indicating drive style. D = Direct Drive V = V-belt
F32	F432	
FH32	FH432	

This bulletin deals exclusively with Pump Models C, F, FH32 and C, F, FH432 General Purpose Pumps. Refer to Figures 1, 2, 4, and 7 for general configuration and nomenclature used in this bulletin.

All pumps can be furnished with either a mechanical seal or packing. Packed pumps are furnished with suitable packing for the liquid pumped. A seal pump can be changed to a packed pump by removing the mechanical seal and inserting the packing spring, inner packing gland, packing and outer packing gland. The mechanical seal pump is dimensionally interchangeable with the packed pump.

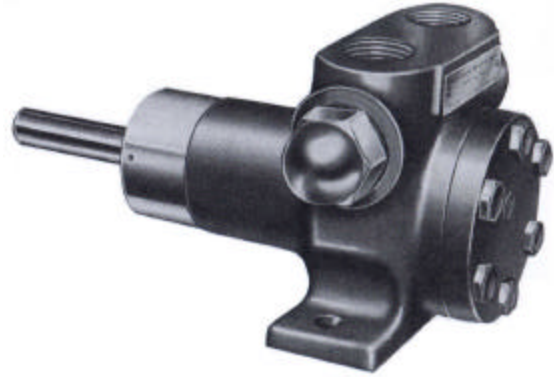

FIGURE 1
SERIES 32 and 432 Pump
3 GPM Size Shown. Packed
or Mechanical Seal type.
Valve on casing – clockwise rotation

SPECIAL INFORMATION

DANGER

BEFORE OPENING ANY VIKING PUMP LIQUID CHAMBER (PUMPING CHAMBER, RESERVOIR, RELIEF VALVE ADJUSTING CAP FITTING ETC.) BE SURE:

1. THAT ANY PRESSURE IN CHAMBER HAS BEEN COMPLETELY VENTED THROUGH SUCTION OR DISCHARGE LINES OR OTHER APPROPRIATE OPENINGS OR CONNECTIONS.
2. THAT THE DRIVING MEANS (MOTOR, TURBINE, ENGINE, ETC.) HAS BEEN "LOCKED OUT" OR MADE NON-OPERATIONAL SO THAT IT CANNOT BE STARTED WHILE WORK IS BEING DONE ON PUMP.
3. THAT YOU KNOW WHAT LIQUID THE PUMP HAS BEEN HANDLING AND THE PRECAUTIONS NECESSARY TO SAFELY HANDLE THE LIQUID. OBTAIN A MATERIAL SAFETY DATA SHEET (MSDS) FOR THE LIQUID TO BE SURE THESE PRECAUTIONS ARE UNDERSTOOD.

FAILURE TO FOLLOW ABOVE LISTED PRECAUTIONARY MEASURES MAY RESULT IN SERIOUS INJURY OR DEATH.

SPECIAL INFORMATION

ROTATION: Viking pumps operate equally well in a clockwise or counterclockwise rotation. Shaft rotation determines which port is suction and which is discharge. Port in area where pumping elements (gear teeth) come out of mesh is suction port.

PRESSURE RELIEF VALVES:

1. Viking pumps are positive displacement pumps and must be provided with some sort of pressure protection. This may be a relief valve mounted directly on the pump, an inline pressure relief valve, a torque limiting device or a rupture disk.
2. This series of pumps may be equipped with an integral pressure relief valve. Standard configuration is for clockwise rotation (suction on the right viewing the shaft end of the pump) but it also may be ordered for counterclockwise rotation. The valve cannot be reversed for opposite rotation.
3. If pump rotation is reversed during operation, pressure protection must be provided on *both* sides of pump.
4. Relief valve adjusting screw cap must *always* point towards suction side of pump.
5. Pressure relief valves cannot be used to control pump flow or regulate discharge pressure.

For additional information on pressure relief valves, refer to Technical Service Manual TSM000 and Engineering Service Bulletin ESB-31.

MAINTENANCE

The Series 32 and 432 pumps are designed for long trouble free life under a wide variety of application conditions with minimum maintenance, however, the following should be considered.

1. **LUBRICATION** – External lubrication not required for this series of pumps. The liquid being pumped lubricates the internal bearings in the pump.
2. **PACKING ADJUSTMENT** – These pumps are designed with a packing spring to maintain a constant load on the packing; no external adjustment is possible. When leakage becomes excessive the packing must be replaced. Refer to re-assembly instruction for proper installation of packing.
3. **END CLEARANCE ADJUSTMENT** – After long term operation it is sometimes possible to improve the performance of the pump, without major repair, by adjusting the end clearance. Refer to instructions under re-assembly of the pump for information regarding this procedure.
4. **SAFETY RELIEF VALVE** – If your pump is equipped with a safety relief valve, adjustment can be made as follows. Remove the adjusting screw cap, turn in the adjusting screw to increase the pressure and turn-out to decrease the pressure. If the pump is not producing the rated capacity adjustment of the safety relief valve may be necessary. Be sure adjusting screw cap is re-installed before pump is started.

MAINTENANCE

5. **CLEANING THE PUMP** - It is good practice to keep the pump as clean as possible. This will facilitate inspection, adjustment and repair work.
6. **STORAGE** - If the pump is to be stored or not used for any appreciable length of time it should be drained and a light coat of lubricating and preservative oil should be applied to the internal parts

SUGGESTED REPAIR TOOLS: The following tools must be available to properly repair Series 32 and 432 pumps. These tools are in addition to standard mechanics' tools such as open end wrenches, pliers, screw drivers, etc. Most of the items can be obtained from an industrial supply house.

1. Soft Headed hammer
2. Allen wrenches (some mechanical seals and set collars)
3. Packing hooks, flexible (packed pumps)
4. Mechanical seal installation sleeve
5. Bearing locknut spanner wrench
(Source: #472 J. H. Williams & Co. or equal)
6. Spanner wrench, adjustable pin type for use on double end caps (Source: #482 J. H. Williams & Co. or equal)
7. Brass bar
8. Arbor press

DISASSEMBLY

DANGER

BEFORE OPENING ANY VIKING PUMP LIQUID CHAMBER (PUMPING CHAMBER, RESERVOIR, RELIEF VALVE ADJUSTING CAP FITTING ETC.) BE SURE:

1. THAT ANY PRESSURE IN CHAMBER HAS BEEN COMPLETELY VENTED THROUGH SUCTION OR DISCHARGE LINES OR OTHER APPROPRIATE OPENINGS OR CONNECTIONS.
2. THAT THE DRIVING MEANS (MOTOR, TURBINE, ENGINE, ETC.) HAS BEEN "LOCKED OUT" OR MADE NON-OPERATIONAL SO THAT IT CANNOT BE STARTED WHILE WORK IS BEING DONE ON PUMP.
3. THAT YOU KNOW WHAT LIQUID THE PUMP HAS BEEN HANDLING AND THE PRECAUTIONS NECESSARY TO SAFELY HANDLE THE LIQUID. OBTAIN A MATERIAL SAFETY DATA SHEET (MSDS) FOR THE LIQUID TO BE SURE THESE PRECAUTIONS ARE UNDERSTOOD.

FAILURE TO FOLLOW ABOVE LISTED PRECAUTIONARY MEASURES MAY RESULT IN SERIOUS INJURY OR DEATH.

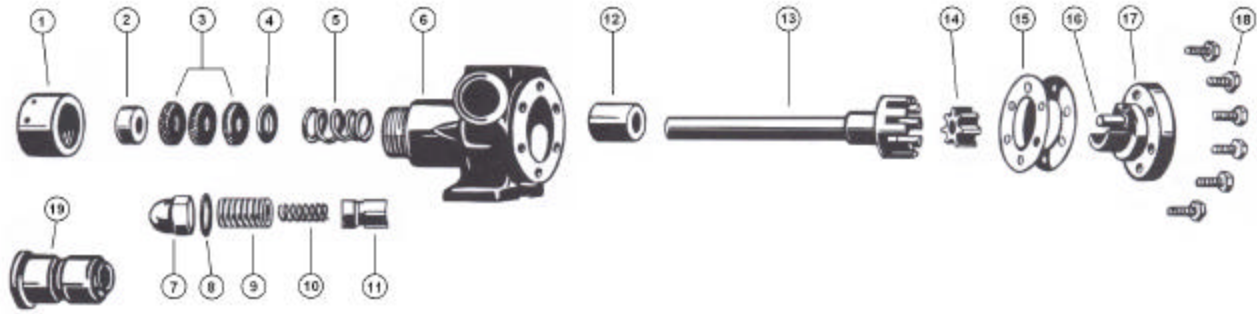

FIGURE 2
EXPLODED VIEW SERIES 32 and 432

ITEM	NAME OF PART	ITEM	NAME OF PART	ITEM	NAME OF PART
1	Packing Nut	8	Gasket for Cap	15	Head Gaskets
2	Outer Packing Gland (Series 32 only)	9	Adjusting Screw	16	Idler Pin
3	Packing (Series 32 only)	10	Spring	17	Head
4	Inner Packing Gland (Series 32 only)	11	Poppet	18	Capscrews
5	Packing Spring (Series32 only)	12	Casing Bushing	19	Mechanical Seal (Series 432 only)
6	Casing	13	Rotor and Shaft		
7	Adjusting Screw Cap	14	Idler		

DISASSEMBLY

1. Remove the capscrews and the head from the pump. It may be necessary to apply a slight pressure on the drive end of the rotor shaft to free the head from the casing. **DO NOT PRY** the head from the casing as this may damage and mar the gasket surfaces.
CAUTION: The rotor and shaft is made of two pieces and the shaft can move in the rotor if tapped too hard. Carefully check Rotor & Shaft Assembly before re-assembling the pump.
2. Remove idler from idler pin. If the idler pin is worn, both the head and idler pin, and idler should be replaced.
3. Next, completely remove the rotor and shaft from the casing by exerting pressure on the drive end of the shaft.
4. Remove the packing nut.
5. The pump is now ready for removal of packing or mechanical seal. Refer to Figure 3 or 5 for example. It is recommended a new mechanical seal or packing be used every time a pump is completely disassembled.

All parts should be examined for wear before the pump is put together. When making major repairs, such as replacing a rotor and shaft, it is usually considered advisable to also install a new casing bushing.

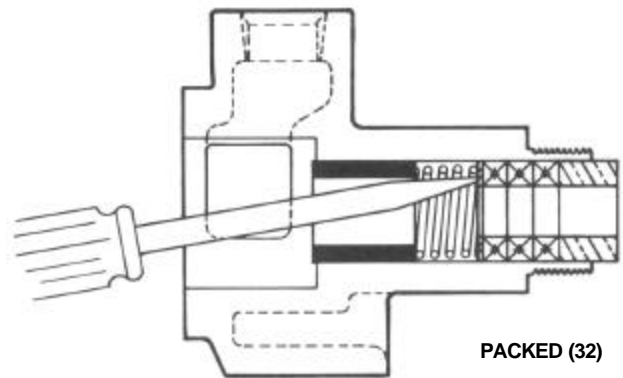

FIGURE 3

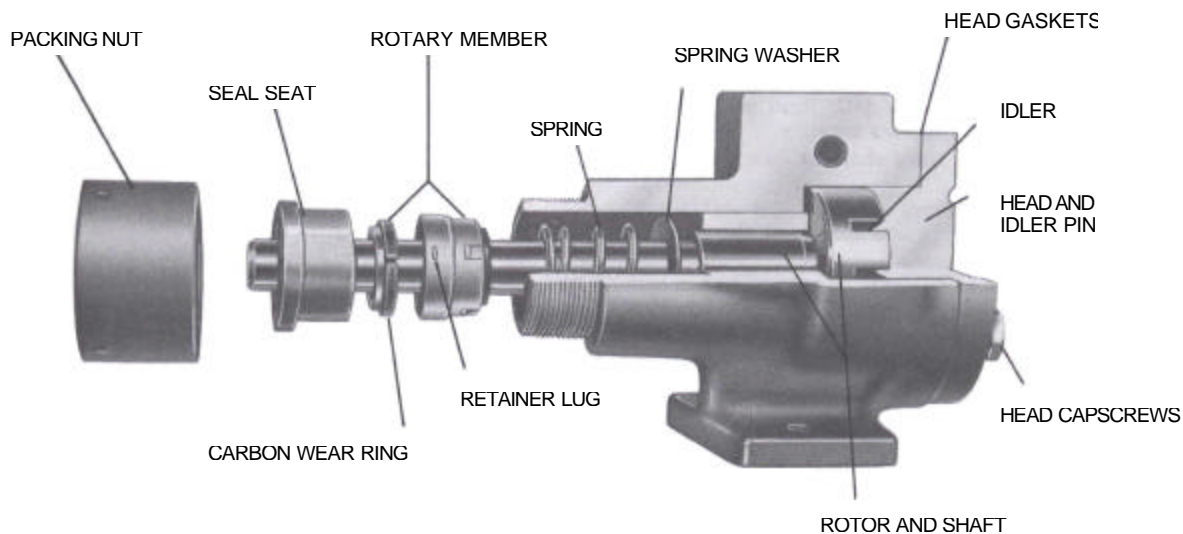

FIGURE 4

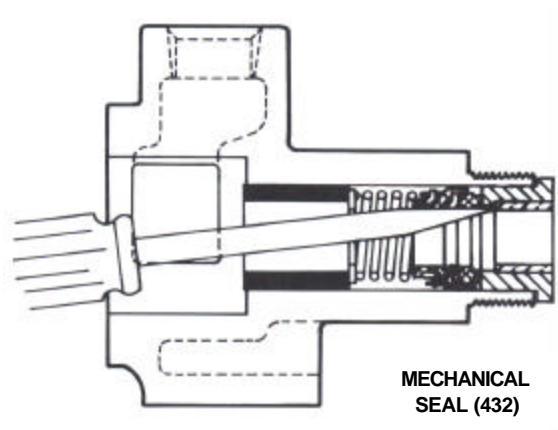

FIGURE 5

Pump Size	"A" Dimension
C	0.88" to 0.94"
F&FH	1.19" to 1.25"

The end clearance within the pump is governed by the location of the casing bushing as well as the number of head gaskets. To correctly position the casing bushing in the casing, see note in step 3 of "RE-ASSEMBLY".

INSTALLING CASING BUSHING

The casing bushing can be replaced in the following manner: Insert a bar approximately 0.94" diameter and at least 3.5" long in the packing or seal end of the casing and press the bushing out of the casing.

When installing a new carbon graphite bushing, extreme care should be taken to prevent breakage as carbon graphite is a brittle material and easily cracked. When cracked the bushing may quickly disintegrate in operation. An arbor press should always be used and the bushing should be installed in one even uninterrupted stroke of the press. Dip the bushing in lube oil and start the bushing in the head end of the casing. Press until located to the "A" dimension in Figure 6.

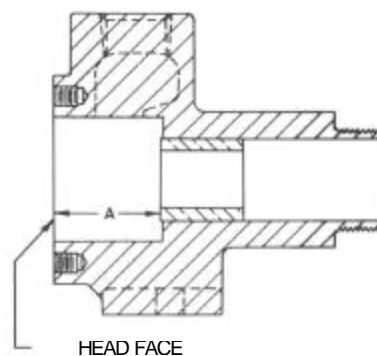

FIGURE 6

REASSEMBLY

1. Clean all parts thoroughly.
2. Place the rotor and shaft in the casing.
3. Put the head gaskets on the head and the idler on the idler pin projecting from the head. Replace the head in the casing; tighten cap screws.

NOTE: If a new casing bushing has been installed in the casing, use only one .002" head gasket on the head and tighten the capscrews evenly and securely. This will correctly position the bushing in the casing. Remove the head, add one .002" head gasket and replace the capscrews and tighten securely.

NOTE: Turn the rotor shaft by hand to be certain it turns freely.

4. When reassembling a mechanical seal pump, place the spring washer and spring on the shaft, see Fig. 4, Page 4. Coat the shaft and the inside of the rubber bellows of the seal rotary member with light oil. Slide the rotary member part way down the shaft.

NOTE: The lapped face of the carbon wear ring must face toward the shaft end of the pump. Be sure the notches on the edge of the carbon wear ring mate with the retainer lugs in the rotary member.

Oil the lapped faces of the rotary member and the seal seat. Slide the seal seat on the shaft until it contacts the rotary member and then push the complete seal into the casing. Replace the packing nut and tighten.

Your pump is now completely assembled. Once again turn the pump shaft by hand to be sure it turns freely. Start the pump with a supply of liquid in the suction line, since the pump should not be run dry.

5. If the pump has packing rather than a mechanical seal, place the spring and inner packing gland on the shaft and slide into the pump. Next install the packing. Stagger the joints in the packing a half turn and add lube oil between each ring of packing. Push the outer packing gland in the casing, and replace the packing nut and tighten.

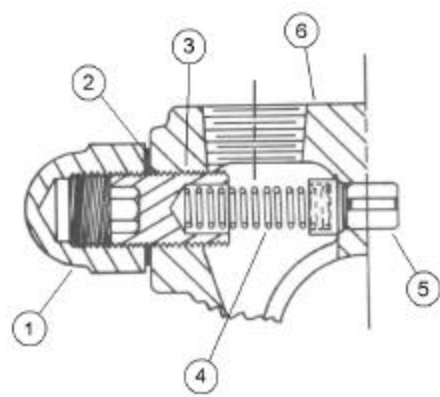

FIGURE 7
SAFETY RELIEF VALVE C, F, FH Size

LIST OF PARTS	
1	Adjusting Screw Cap
2	Gasket for Cap
3	Adjusting Screw
4	Spring
5	Poppet
6	Casing

SAFETY RELIEF VALVE

The relief valve is a safety device to protect the pump and motor against excessive pressure. A pump without a properly set safety relief valve operating against a closed discharge line could build up enough pressure to damage the pump or motor.

The pressure setting is increased by turning the adjusting screw in and decreased by turning the adjusting screw out.

SPECIAL PUMP DESIGNS

Pumps furnished with a Teflon Mechanical seal require a special rotor and shaft with drive pin installed for positive drive of the rotating member. All other assembly and disassembly instructions are the same.

DANGER

BEFORE STARTING PUMP, BE SURE ALL DRIVE EQUIPMENT GUARDS ARE IN PLACE.

FAILURE TO PROPERLY MOUNT GUARDS MAY RESULT IN SERIOUS INJURY OR DEATH.



TECHNICAL SERVICE MANUAL

GENERAL PURPOSE PUMPS
SERIES 32 and 432
SIZES C - F - FH

SECTION TSM 310.1
PAGE 6
ISSUE B



WARRANTY

Viking warrants all products manufactured by it to be free from defects in workmanship or material for a period of one (1) year from date of startup, provided that in no event shall this warranty extend more than eighteen (18) months from the date of shipment from Viking. If, during said warranty period, any products sold by Viking prove to be defective in workmanship or material under normal use and service, and if such products are returned to Viking's factory at Cedar Falls, Iowa, transportation charges prepaid, and if the products are found by Viking to be defective in workmanship or material, they will be replaced or repaired free of charge, FOB. Cedar Falls, Iowa.

Viking assumes no liability for consequential damages of any kind and the purchaser by acceptance of delivery assumes all liability for the consequences of the use or misuse of Viking products by the purchaser, his employees or others. Viking will assume no field expense for service or parts unless authorized by it in advance.

Equipment and accessories purchased by Viking from outside sources which are incorporated into any Viking product are warranted only to the extent of and by the original manufacturer's warranty or guarantee, if any.

THIS IS VIKING'S SOLE WARRANTY AND IS IN LIEU OF ALL OTHER WARRANTIES, EXPRESSED OR IMPLIED, WHICH ARE HEREBY EXCLUDED, INCLUDING IN PARTICULAR ALL WARRANTIES OF MERCHANTABILITY OR FITNESS FOR A PARTICULAR PURPOSE. No officer or employee of IDEX Corporation or Viking Pump, Inc. is authorized to alter this warranty.

