



509 & 511 POWER BACKHOES OPERATOR'S MANUAL



PALADIN
LIGHT CONSTRUCTION GROUP



The Power of Combined Excellence



SERIAL NUMBER: _____

MODEL NUMBER: _____

Manual Number: OM575
Part Number: 75475
Rev. 4

TABLE OF CONTENTS

POWER BACKHOES

PREFACE	3
SAFETY PRECAUTIONS	
SAFETY STATEMENTS	5
GENERAL SAFETY PRECAUTIONS	5-7
EQUIPMENT SAFETY PRECAUTIONS.....	8
DECALS	
DECAL PLACEMENT	9
DECALS.....	10-13
PRE-OPERATION	
GENERAL INFORMATION	14
PREPARING THE VEHICLE.....	14
BACKHOE BUCKET OPTIONS.....	14
NOMENCLATURE	15
OPERATING INSTRUCTIONS	
GENERAL INFORMATION	16
CONTROLS	16
BEFORE YOU START DIGGING	17-18
BASIC DIGGING TECHNIQUES	19-20
SPECIAL APPLICATIONS	20-24
TRANSPORTING.....	25
LUBRICATION	
LUBRICATION SYMBOLS AND DIAGRAM	26-27
MAINTENANCE AND SERVICE	
GENERAL INFORMATION	28
EVERY 8 HOURS	28
EVERY 40 HOURS	28
CONTROL VALVE	29
REPLACING BUCKET TOOTH POINTS.....	29
CHANGING BUCKETS.....	29
BUCKET DIGGING POSITIONS	30
HOSE ROUTING	31
CYLINDER SEAL REPLACEMENT.....	32-33
STORAGE	34
TROUBLESHOOTING	35-37
SPECIFICATIONS	
BOLT TORQUE SPECIFICATIONS	38
BACKHOE SPECIFICATIONS.....	39
CYLINDER AND BUCKET SPECIFICATIONS	40
PRE-DELIVERY CHECK LIST	41
LIMITED WARRANTY	43

**THIS PAGE
IS INTENTIONALLY
BLANK**

PREFACE

GENERAL COMMENTS

Congratulations on the purchase of your new BRADCO product! This product was carefully designed and manufactured to give you many years of dependable service. Only minor maintenance (such as cleaning and lubricating) is required to keep it in top working condition. Be sure to observe all maintenance procedures and safety precautions in this manual and on any safety decals located on the product and on any equipment on which the attachment is mounted.

This manual has been designed to help you do a better, safer job. Read this manual carefully and become familiar with its contents.

WARNING!  Never let anyone operate this unit without reading the "Safety Precautions" and "Operating Instructions" sections of this manual. Always choose hard, level ground to park the vehicle on and set the brake so the unit cannot roll.

Unless noted otherwise, right and left sides are determined from the operator's control position when facing the attachment.

NOTE: The illustrations and data used in this manual were current (according to the information available to us) at the time of printing, however, we reserve the right to redesign and change the attachment as may be necessary without notification.

BEFORE OPERATION

The primary responsibility for safety with this equipment falls to the operator. Make sure the equipment is operated only by trained individuals that have read and understand this manual. If there is any portion of this manual or function you do not understand, contact your local authorized dealer or the manufacturer.

SAFETY ALERT SYMBOL



This is the "Safety Alert Symbol" used by this industry. This symbol is used to warn of possible injury. Be sure to read all warnings carefully. They are included for your safety and for the safety of others working with you.

SERVICE

When servicing your product, remember to use only manufacturer replacement parts. Substitute parts may not meet the standards required for safe, dependable operation.

To facilitate parts ordering, record the model and serial number of your unit in the space provided on the cover of this manual. This information may be obtained from the identification plate located on the product.

The parts department needs this information to ensure that you receive the correct parts for your specific model.

**THIS PAGE
IS INTENTIONALLY
BLANK**

SAFETY STATEMENTS



THIS SYMBOL BY ITSELF OR WITH A WARNING WORD THROUGHOUT THIS MANUAL IS USED TO CALL YOUR ATTENTION TO INSTRUCTIONS INVOLVING YOUR PERSONAL SAFETY OR THE SAFETY OF OTHERS. FAILURE TO FOLLOW THESE INSTRUCTIONS CAN RESULT IN INJURY OR DEATH.



DANGER

THIS SIGNAL WORD IS USED WHERE SERIOUS INJURY OR DEATH WILL RESULT IF THE INSTRUCTIONS ARE NOT FOLLOWED PROPERLY.



WARNING

THIS SIGNAL WORD IS USED WHERE SERIOUS INJURY OR DEATH COULD RESULT IF THE INSTRUCTIONS ARE NOT FOLLOWED PROPERLY.



CAUTION

THIS SIGNAL WORD IS USED WHERE MINOR INJURY COULD RESULT IF THE INSTRUCTIONS ARE NOT FOLLOWED PROPERLY.

NOTICE

NOTICE INDICATES A PROPERTY DAMAGE MESSAGE.

GENERAL SAFETY PRECAUTIONS

WARNING!

READ MANUAL PRIOR TO INSTALLATION



Improper installation, operation, or maintenance of this equipment could result in serious injury or death. Operators and maintenance personnel should read this manual, as well as all manuals related to this equipment and the prime mover thoroughly before beginning installation, operation, or maintenance. **FOLLOW ALL SAFETY INSTRUCTIONS IN THIS MANUAL AND THE PRIME MOVER'S MANUAL(S).**



READ AND UNDERSTAND ALL SAFETY STATEMENTS

Read all safety decals and safety statements in all manuals prior to operating or working on this equipment. Know and obey all OSHA regulations, local laws, and other professional guidelines for your operation. Know and follow good work practices when assembling, maintaining, repairing, mounting, removing, or operating this equipment.



KNOW YOUR EQUIPMENT

Know your equipment's capabilities, dimensions, and operations before operating. Visually inspect your equipment before you start, and never operate equipment that is not in proper working order with all safety devices intact. Check all hardware to ensure it is tight. Make certain that all locking pins, latches, and connection devices are properly installed and secured. Remove and replace any damaged, fatigued, or excessively worn parts. Make certain all safety decals are in place and are legible. Keep decals clean, and replace them if they become worn or hard to read.

GENERAL SAFETY PRECAUTIONS

WARNING!



PROTECT AGAINST FLYING DEBRIS

Always wear proper safety glasses, goggles, or a face shield when driving pins in or out, or when any operation causes dust, flying debris, or any other hazardous material.

WARNING!



LOWER OR SUPPORT RAISED EQUIPMENT

Do not work under raised booms without supporting them. Do not use support material made of concrete blocks, logs, buckets, barrels, or any other material that could suddenly collapse or shift positions. Make sure support material is solid, not decayed, warped, twisted, or tapered. Lower booms to ground level or on blocks. Lower booms and attachments to the ground before leaving the cab or operator's station.

WARNING!



USE CARE WITH HYDRAULIC FLUID PRESSURE

Hydraulic fluid under pressure can penetrate the skin and cause serious injury or death. Hydraulic leaks under pressure may not be visible. Before connecting or disconnecting hydraulic hoses, read your prime mover's operator's manual for detailed instructions on connecting and disconnecting hydraulic hoses or fittings.

- Keep unprotected body parts, such as face, eyes, and arms as far away as possible from a suspected leak. Flesh injected with hydraulic fluid may develop gangrene or other permanent disabilities.
- If injured by injected fluid, see a doctor at once. If your doctor is not familiar with this type of injury, ask him to research it immediately to determine proper treatment.
- Wear safety glasses, protective clothing, and use a piece of cardboard or wood when searching for hydraulic leaks. **DO NOT USE YOUR HANDS!** **SEE ILLUSTRATION.**

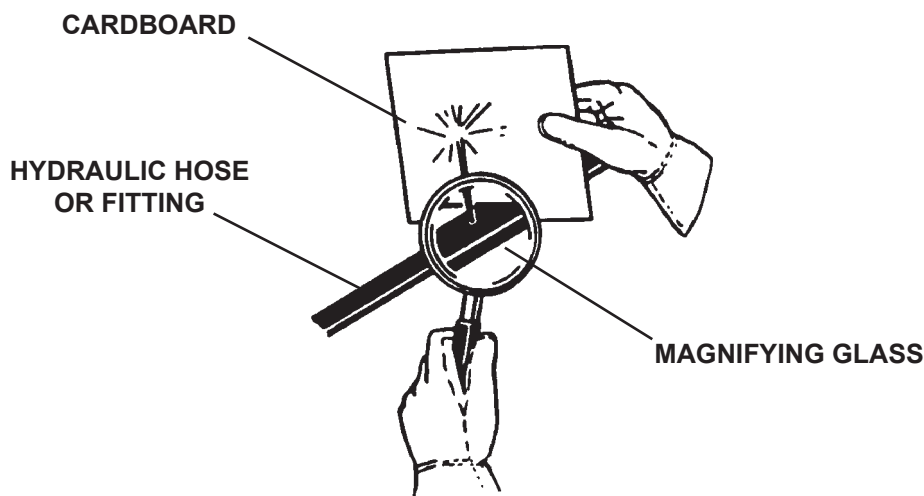

GENERAL SAFETY PRECAUTIONS

WARNING!



DO NOT MODIFY MACHINE OR ATTACHMENTS

Modifications may weaken the integrity of the attachment and may impair the function, safety, life, and performance of the attachment. When making repairs, use only the manufacturer's genuine parts, following authorized instructions. Other parts may be substandard in fit and quality. Never modify any ROPS (Roll Over Protection Structure) or FOPS (Falling Object Protective Structure) equipment or device. Any modifications must be authorized in writing by the manufacturer.

WARNING!



SAFELY MAINTAIN AND REPAIR EQUIPMENT

- Do not wear loose clothing or any accessories that can catch in moving parts. If you have long hair, cover or secure it so that it does not become entangled in the equipment.
- Work on a level surface in a well-lit area.
- Use properly grounded electrical outlets and tools.
- Use the correct tools for the job at hand. Make sure they are in good condition for the task required.
- Wear the protective equipment specified by the tool manufacturer.



SAFELY OPERATE EQUIPMENT

Do not operate equipment until you are completely trained by a qualified operator in how to use the controls, know its capabilities, dimensions, and all safety requirements. See your machine's manual for these instructions.

- Keep all step plates, grab bars, pedals, and controls free of dirt, grease, debris, and oil.
- Never allow anyone to be around the equipment when it is operating.
- Do not allow riders on the attachment or the prime mover.
- Do not operate the equipment from anywhere other than the correct operator's position.
- Never leave equipment unattended with the engine running, or with this attachment in a raised position.
- Do not alter or remove any safety feature from the prime mover or this attachment.
- Know your work site safety rules as well as traffic rules and flow. When in doubt on any safety issue, contact your supervisor or safety coordinator for an explanation.

EQUIPMENT SAFETY PRECAUTIONS

WARNING! KNOW WHERE UTILITIES ARE



Observe overhead electrical and other utility lines. Be sure equipment will clear them. When digging, call your local utilities for location of buried utility lines, gas, water, and sewer, as well as any other hazard you may encounter.



OPERATING THE BACKHOE

- Block off work area from bystanders, livestock, etc. Allow plenty of room for backhoe swing.
- Operate only from the operator's station.
- Use the backhoe only for digging. Do not use the backhoe to pull things, as a battering ram, or attach ropes, chains etc., to the unit.
- Do not dig close to the stabilizers. The ground could collapse from under the backhoe.
- Do not lift loads in excess of the capacity of the backhoe or prime mover.
- When operating on slopes, dig with the backhoe uphill, and avoid swinging the backhoe to the downhill side. Avoid steep hillside operation, which could cause the prime mover to overturn.
- Reduce speed when driving over rough terrain, on a slope, or turning, to avoid overturning the vehicle.
- Do not adjust relief valve settings. Incorrect valve settings could result in equipment damage and/or personal injury.
- An operator must not use drugs or alcohol, which can change his or her alertness or coordination. An operator taking prescription or over-the-counter drugs should seek medical advice on whether or not he or she can safely operate equipment.
- Before exiting the prime mover, lower the backhoe bucket and stabilizers to the ground, turn off the prime mover's engine, remove the key and apply the brakes.



TRANSPORTING THE BACKHOE

- Be sure to engage boom and swing locks before transporting backhoe to prevent uncontrolled movement.
- When driving on public roads use safety lights, reflectors, Slow Moving Vehicle signs etc., to prevent accidents. Check local government regulations that may affect you.
- Do not drive close to ditches, excavations, etc., cave in could result.
- Do not smoke when refueling the prime mover. Allow room in the gas tank for expansion. Wipe up any spilled fuel. Secure cap tightly when done.



MAINTAINING THE BACKHOE

- Before performing maintenance, lower the attachment to the ground, turn off the engine, remove the key and apply the brakes.
- Never perform any work on the attachment unless you are authorized and qualified to do so. Always read the operator service manual's before any repair is made. After completing maintenance or repair, check for correct functioning of the backhoe. If not functioning properly, always tag "DO NOT OPERATE" until all problems are corrected.
- Worn, damaged, or illegible safety decals must be replaced. New safety decals can be ordered from BRADCO.
- Never make hydraulic repairs while the system is under pressure, or cylinders under load. Serious personal injury or death could result.
- Never work under a raised attachment.

10492 2-13-06

DECALS

DECAL PLACEMENT

GENERAL INFORMATION

The diagrams on this page shows the location of all the decals used on the 500 series backhoes. The decals are identified by their part numbers, with reductions of the actual decals located on the following pages. Use this information to order replacements for lost or damaged decals. Be sure to read all decals before operating the backhoe. They contain information you need to know for both safety and backhoe longevity.

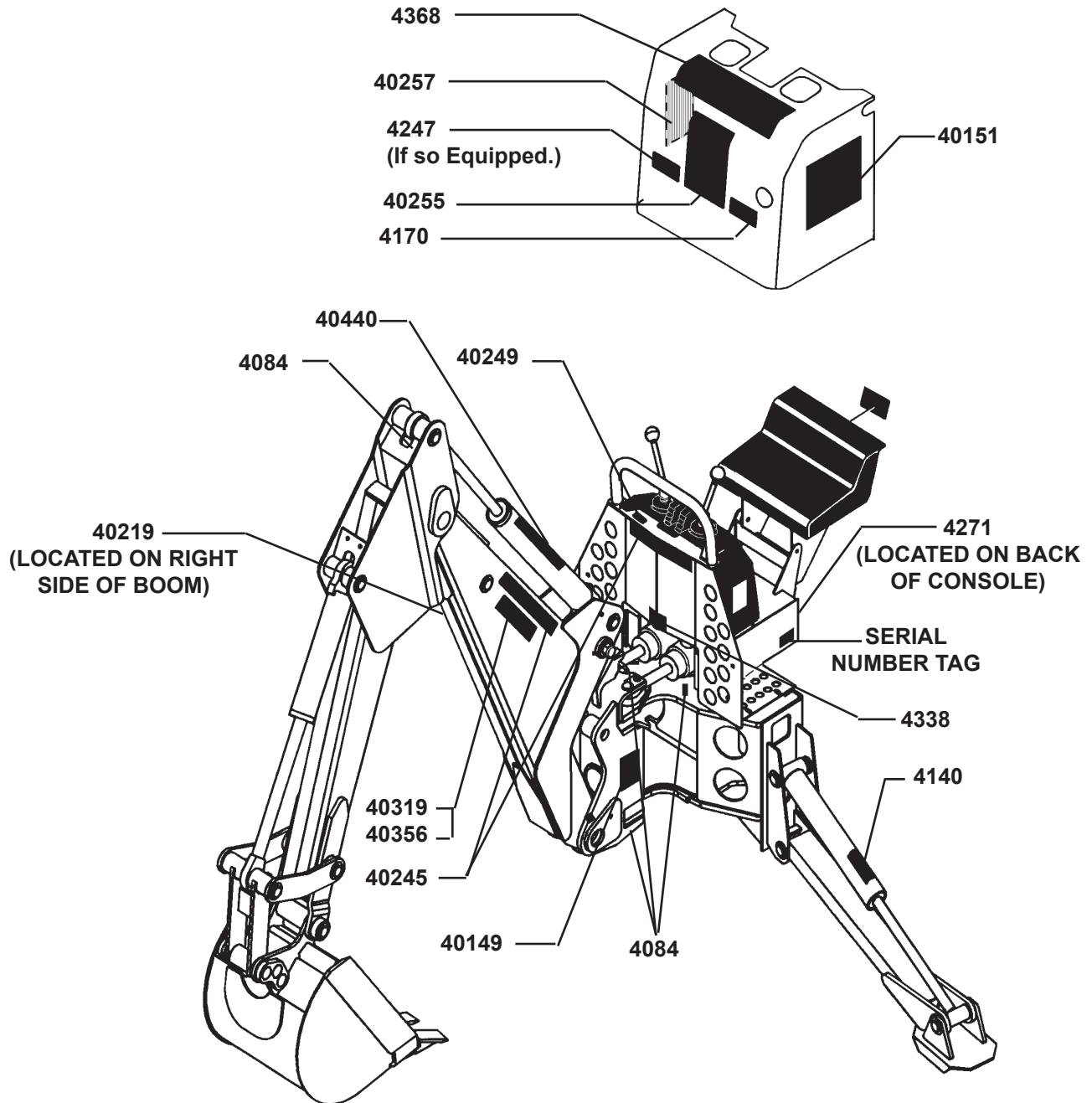

IMPORTANT: Keep all safety signs clean and legible. Replace all missing, illegible, or damaged safety signs. When replacing parts with safety signs attached, the safety signs must also be replaced.

REPLACING SAFETY SIGNS: Clean the area of application with nonflammable solvent, then wash the same area with soap and water. Allow the surface to fully dry. Remove the backing from the safety sign, exposing the adhesive surface. Apply the safety sign to the position shown in the diagram above and smooth out any bubbles.

7477 7-7-10-4

DECALS

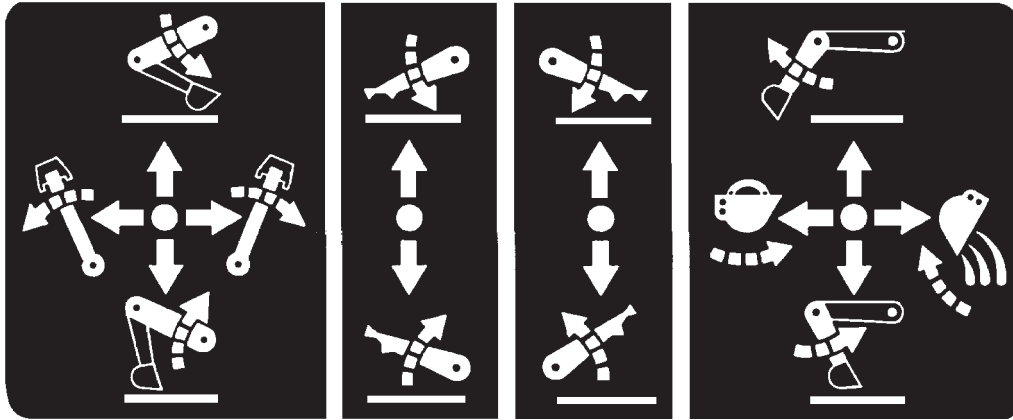

**PART #4368
OPERATING CONTROLS DECAL**

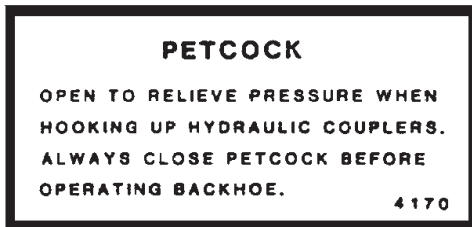

**PART #4170
PETCOCK OPERATION DECAL**

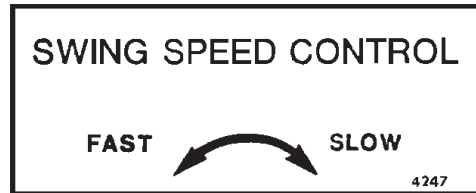

**PART #4247
SWING SPEED CONTROL DECAL**

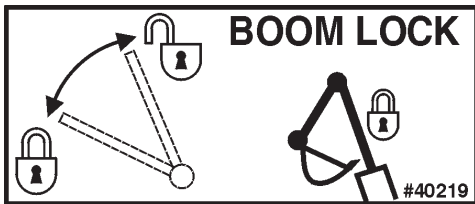

**PART #40219
BOOM LOCK DECAL**

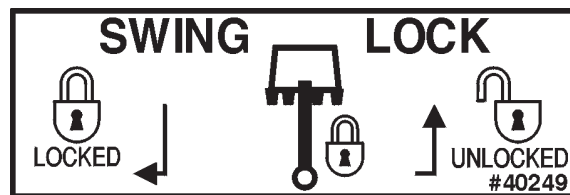

**PART #40249
SWING LOCK DECAL**

DECALS

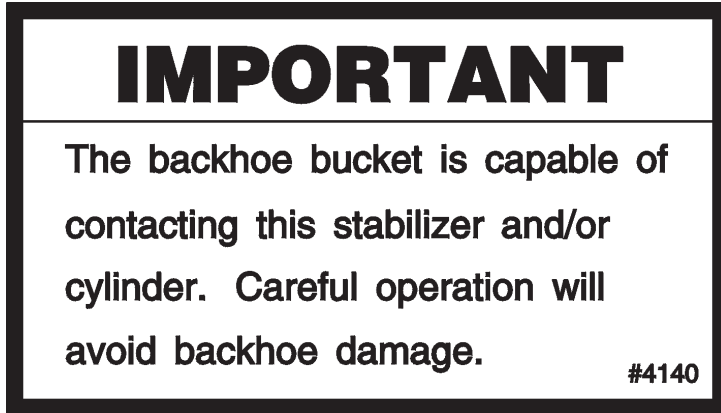

PART #4140
BUCKET CONTACT WARNING DECAL



PART #4338
MADE IN U.S.A. DECAL



PART #40440
CALL BEFORE YOU DIG

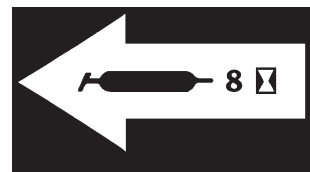

PART #4084
GREASE 8 HOURS

DECALS

 WARNING		
		
HIGH-PRESSURE FLUID HAZARD		
To prevent serious injury or death:		
<ul style="list-style-type: none"> • Relieve pressure on system before repairing or adjusting or disconnecting. • Wear proper hand and eye protection when searching for leaks. Use wood or cardboard instead of hands. • Keep all components in good repair. 		

PART #40151
HIGH PRESSURE FLUID DECAL

 DANGER	
	<p>To Prevent Serious Injury or Death from Crushing:</p> <p>Verify the backhoe is securely attached to the prime mover.</p> <ul style="list-style-type: none"> • Check mounting bolts for tightness. • Visually check for proper pin engagement before operating. <p>#41169</p>

PART #41169
DANGER! BACKHOE SECURE

IMPORTANT
TO PREVENT BACKHOE DAMAGE:
<ul style="list-style-type: none"> • DO NOT ATTACH TOW CHAIN TO DIPPER OR BUCKET. • DO NOT REPEATEDLY SLAM SWING POST INTO SWING STOPS.
PREPARATION FOR STORAGE
<p>LUBRICATE ALL GREASE POINTS. LEAVE AS MANY CYLINDERS IN CLOSED POSITION AS POSSIBLE. COVER ALL EXPOSED CYLINDER RODS WITH A LIGHT COAT OF GREASE.</p> <p>#40257</p>

PART #40257
IMPORTANT! DECAL

 WARNING
TO PREVENT SERIOUS INJURY OR DEATH:
<ul style="list-style-type: none"> • Do not operate or work on this machine without reading and understanding Operator's Manual. • Avoid unsafe operation or maintenance. • Do not operate machine with guards and covers removed. • This machine was designed to be operated by one operator. Do not carry passengers on unit. • Before installing backhoe on your unit extend boom and dipperstick and lower bucket to ground. • Never use backhoe as manlift. • Operate backhoe control levers from operator's seat only. Lower stabilizers and bucket to ground before leaving operator's seat. • Engage boom lock and swing lock before transporting backhoe.
#40255

PART #40255
OPERATIONAL WARNING DECAL

 DANGER		
		
<p>To prevent serious injury or death from pinching:</p> <ul style="list-style-type: none"> • Keep all persons and objects clear while any part of this machine is in motion. 		

PART #40149
DANGER! PINCH POINTS

DECALS

BRADCO®

PART #40245 (3 REQ'D)
BRADCO LOGO - SILBER

509

PART #40319 (2 REQ'D)
509 MODEL NUMBER

511

PART #40356 (2 REQ'D)
511 MODEL NUMBER

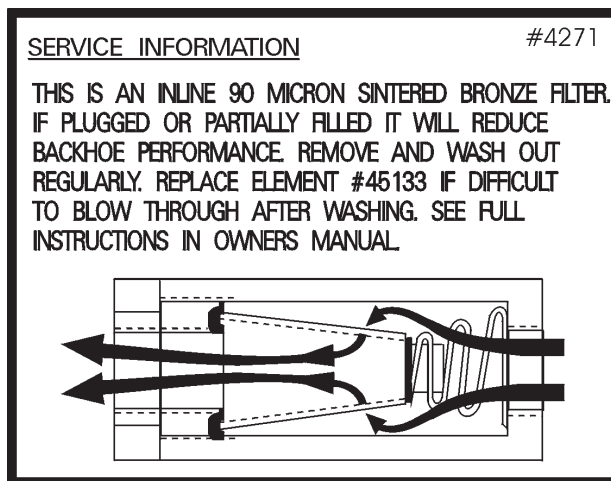

PART #4271
INLINE FILTER DECAL

PRE-OPERATION

509 & 511 POWER BACKHOE

GENERAL INFORMATION

The purpose of this manual is to assist in setting up, operating and maintaining your backhoe. Read it carefully. It furnishes information and instructions that will help you achieve years of dependable performance.

Right and left, when referred to in this manual, are determined from the operator's control position when facing the backhoe.

The illustrations and data used in this manual were current (according to the information available to us) at the time of printing, however, we reserve the right to redesign and change the backhoes as may be necessary without notification.

PREPARING THE VEHICLE

WARNING! Never let anyone operate this tractor and backhoe without understanding all of the "Safety Precautions" and "Operating Instructions" sections of this manual. (See Section B and G respectively.) Always choose hard, level ground to park the tractor on and set the brake so that the tractor cannot roll.



BACKHOE

Basic backhoes are shipped complete with bucket. However, several bucket options are available for the backhoe. Refer to the table for proper identification of backhoe bucket options.

SEVERE DUTY POWER DIG BUCKET ASSEMBLIES

12"	#85012
16"	#85016
18"	#85018
20"	#85020
24"	#85024

Additional buckets available upon request.

PRE-OPERATION

NOMENCLATURE

Throughout this manual, reference is made to various backhoe components. Study the following diagram to acquaint yourself with the various names of these components. This knowledge will be helpful when reading through this manual or when ordering service parts.

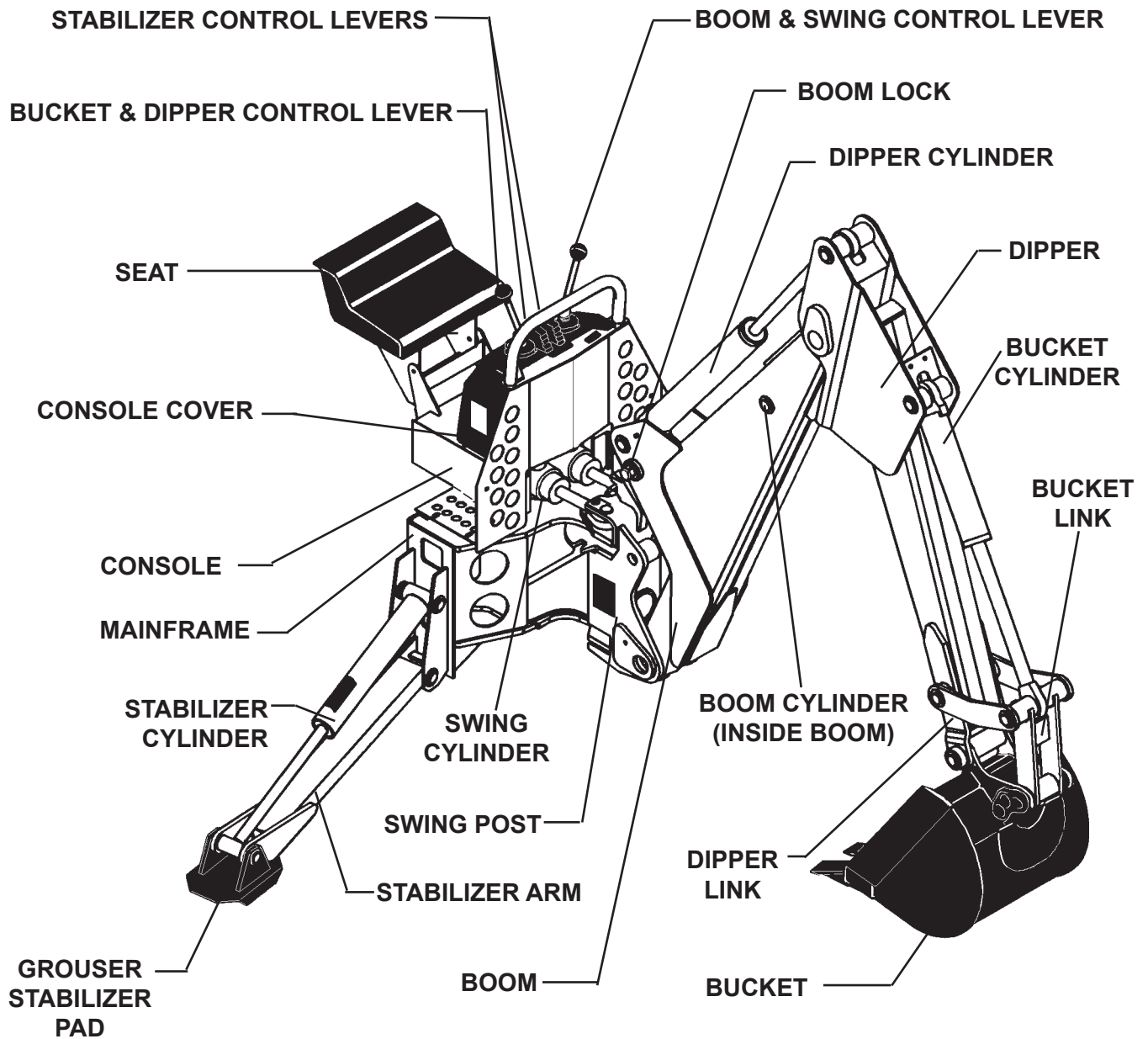

OPERATING INSTRUCTIONS

CONTROLS

GENERAL INFORMATION

Your backhoe is operated by four different control levers. Two are for stabilizer operation and the other two operate the swing, boom, dipper, and bucket functions. The information contained below will help you become familiar with the operation of each control lever. Read the Safety Precautions section of this manual before attempting to use the backhoe. Remember, right and left when referred to on this page are determined by the operator's position seated at the backhoe controls facing the bucket.

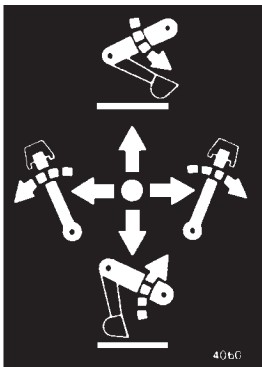

**BOOM/SWING
CONTROL LEVER**

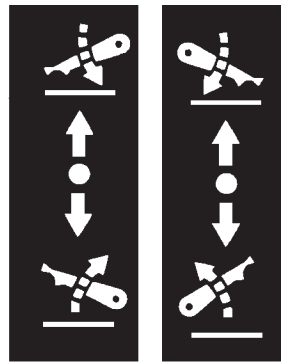

**LEFT RIGHT
STABILIZERS**

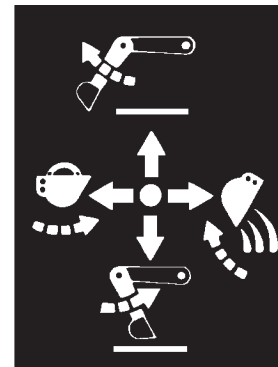

**DIPPER/BUCKET
CONTROL LEVER**

BACKHOE STABILIZER LEVERS

Moving the stabilizer lever(s) forward will bring the backhoe stabilizers "Down". Moving the stabilizer lever(s) rearward will raise the backhoe stabilizers "Up". Both stabilizers are required to be down for proper stability of the backhoe when in operation.

BOOM/SWING LEVER (LEFT HAND LEVER)

Pushing the boom/swing lever forward will "Lower" the boom dipstick and bucket. Pulling the lever rearward will "Lift" the boom, dipstick, and bucket.

Pushing the boom/swing lever to the left will swing the boom and bucket to the "Left". Pushing the lever to the right will swing the boom, and bucket to the "Right".

DIPPER/BUCKET LEVER (RIGHT HAND LEVER)

Pushing the dipper/bucket lever forward will move the dipper "Out" or away from the operator. Pulling the lever rearward will move (crowd) the dipper "In" or toward the operator.

Pushing the dipper/bucket lever to the left will "Fill" or curl the bucket (move inward). Pushing the lever to the right will "Dump" the bucket (move outward).

OPERATING INSTRUCTIONS

OPERATING TECHNIQUES ATTACHMENT TYPE BACKHOES

GENERAL INFORMATION

When operating the backhoe, smoothness of technique should be strived for at all times. Smoothness will come with experience and practice at feathering the controls. Establish a flowing digging cycle to increase operator efficiency and save unnecessary wear on the machine.

Observe the following points to obtain the best results and to fully utilize the digging force of the backhoe.

WARNING! Operate the backhoe only when seated at the controls. Any other method could result in serious personal injury or death.



Never attempt to drive the tractor when seated at the backhoe controls.

Check the prospective digging area for hidden utility lines before operating the backhoe or when in doubt of their location, contact the local utility companies. When operating the backhoe in an area where utilities are expected to be present, throttle the backhoe down and proceed with caution. If you feel the backhoe bucket made contact with anything out of the ordinary, stop digging at once. Have the obstruction checked by hand. If a utility line has been damaged, contact the affected utility at once.

BEFORE YOU START DIGGING

Before any excavating is started, it is always a good idea to plan out the job first. Various things need to be considered and taken into account prior to the actual digging. The operator should inspect the job site and take notice of any potential hazards in the area. He should have a complete understanding of the tasks he is expected to perform. Figure out what will be done with the spoil (excavated soil), will it be used to backfill or be trucked out? What are the soil conditions like? Will you have to work around others? Etc.

Once you have become familiar with the job site and understand the job requirements, it is time to set up for the actual digging. Position the backhoe in such a way as to minimize repositioning the unit and to maximize digging efficiency. Consider the placement of spoil and position the backhoe to be able to dig the maximum amount of soil, accurately, while leaving enough room for the spoil removed to be piled in the desired area.

OPERATING INSTRUCTIONS

OPERATING TECHNIQUES

ATTACHMENT TYPE BACKHOES

BEFORE YOU START DIGGING (CONTINUED)

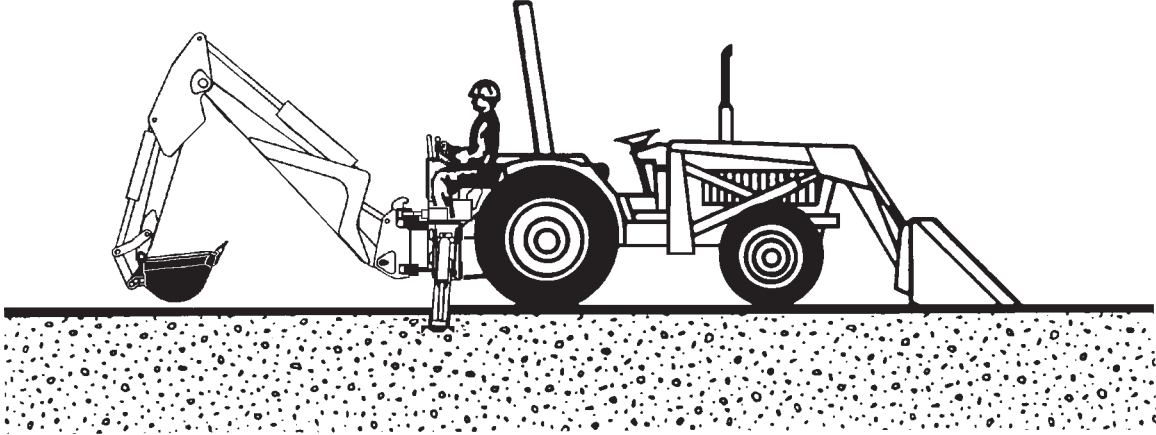

Once the unit is positioned, lower the stabilizers to the ground. The tires should still be supporting most of the vehicle weight with the stabilizers relieving only part of the weight, and mainly acting to give the unit a wider base for increased stability and to keep the unit from moving or bouncing with backhoe use. The front end loader should also be lowered if the unit is so equipped. The vehicle should at no time be supported by the stabilizers and loader with any of its wheels off the ground. Severe damage to the vehicle could result. When operating the unit on a delicate surface (such as concrete, or stone work) or on sandy, loose, or soft ground place plywood under the stabilizers to help distribute the load over a wider area.

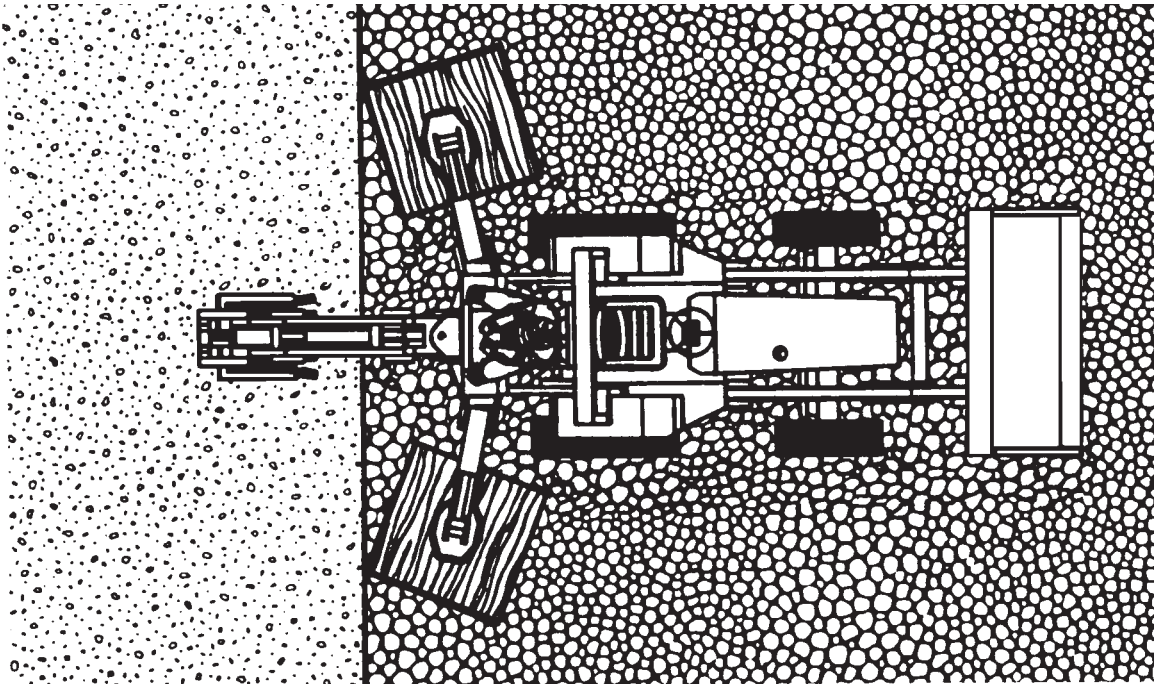

OPERATING INSTRUCTIONS

OPERATING TECHNIQUES

ATTACHMENT TYPE BACKHOES

BASIC DIGGING TECHNIQUE

When starting an excavation, make the first cut of each section shallow, being careful to follow the exact layout of the excavation. The reason for the shallow cut is to minimize damage to the sod and to facilitate replacement. These first cuts are also important because they will act as guides for the remaining cuts, thus getting the first few cuts as accurate as possible will help in keeping all future cuts accurate.

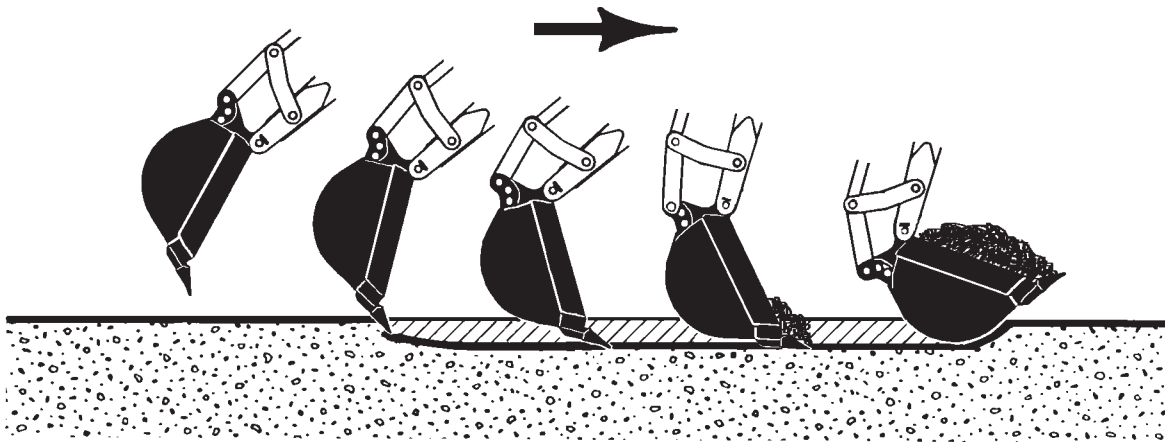

When digging with the backhoe, extend the boom, dipper and bucket out, away from the operator. Lower the boom and dipper to start the digging process. The bucket teeth should be at a 30° to 45° entry angle. As the digging starts, curl the bucket until the cutting edge is level with the horizon. Crowd the bucket in toward the operator working the bucket lever to keep the bucket level. As the bucket moves toward the operator, manipulate the boom lever to keep the cut level. At the end of the digging cycle, crowd the dipper out and completely curl the bucket while lifting it from the excavation. Once you have cleared the excavation, swing the bucket to the spoil pile. Start to dump the bucket before the pile is approached. Once the bucket is empty, swing the unit back to the excavation, positioning the bucket and dipper for the next cut in the process. The whole digging process should be one smooth cycle that is repeated until the excavation is completed.

When the excavation has been dug to within six inches of the finished bottom, clear and touch up the sides of the excavation. Use the flat sides of the bucket to scrape off any high spots. Dislodge any exposed rocks if they seem loose. When finishing walls, finish the far wall by curling the bucket out, crowding the dipper out, and forcing the bucket down. To finish the closest wall, lift the bucket up and curl it in.

OPERATING INSTRUCTIONS

OPERATING TECHNIQUES ATTACHMENT TYPE BACKHOES

BASIC DIGGING TECHNIQUES (CONTINUED)

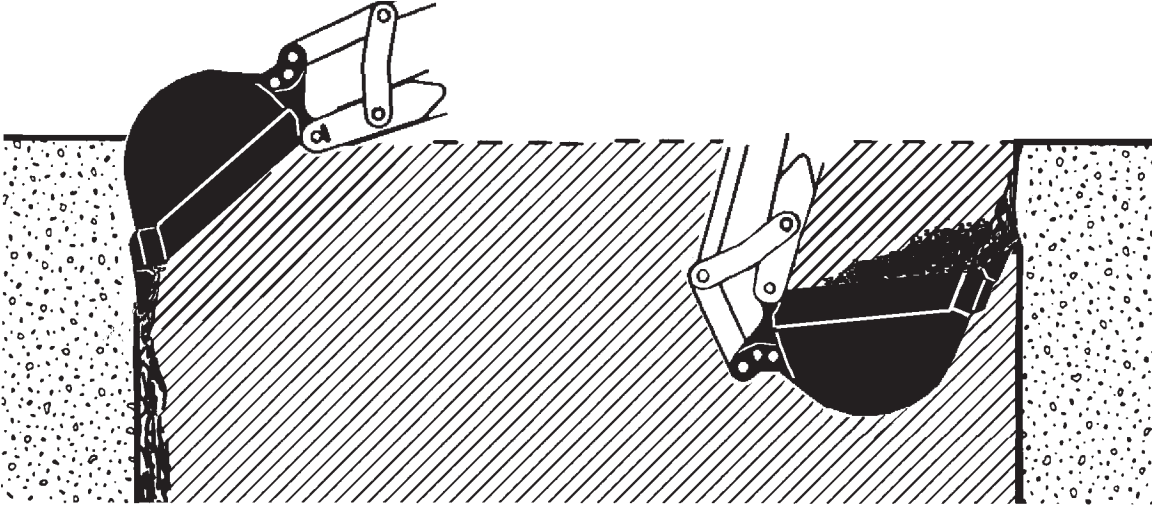

Once the sides are cleaned up, finish grading the bottom of the excavation. This is done by making the remaining cuts long and shallow, concentrating on making them level and smooth. Remove any remaining spoil. Check the excavation bottom for depth and levelness, making any adjusting cuts as needed.

The basic steps just listed at the same regardless of the excavation. All other digging jobs are simply variations of this basic procedure. Remember to make your cuts in smooth cycles. This will reduce operator fatigue and machine wear while increasing productivity and efficiency.

SPECIAL APPLICATIONS

TRENCHING BETWEEN A BUILDING AND AN OPEN EXCAVATION

Start the trench at the building and trench toward the open excavation. Dig toward the open excavation until there is just enough room to move the unit out from between the trench and open excavation.

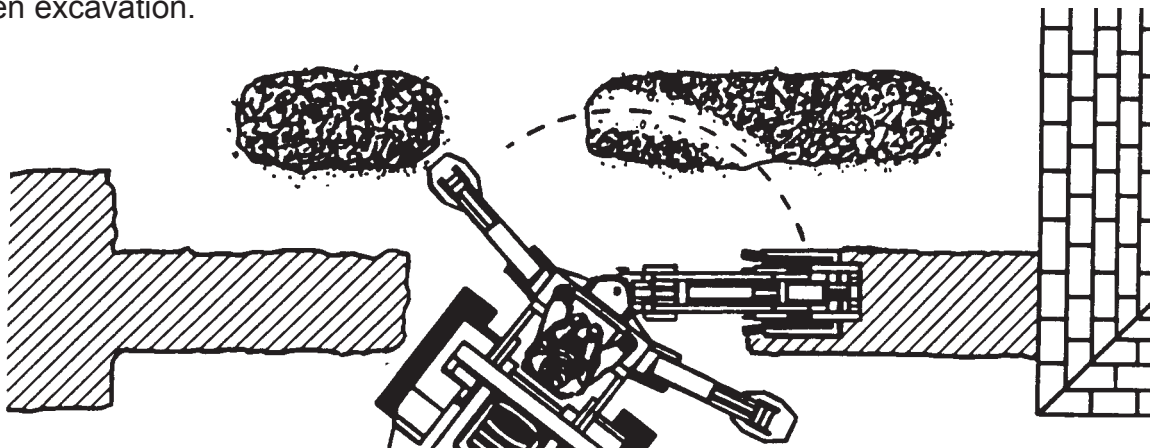

6881 1-25-06-2

OPERATING INSTRUCTIONS

OPERATING TECHNIQUES ATTACHMENT TYPE BACKHOES

TRENCHING BETWEEN A BUILDING AND AN OPEN EXCAVATION (CONTINUED)

Position the unit so the backhoe swing post is over the center line of the trench connection. Dig with the backhoe at extreme swing positions, and in as close to the stabilizers as possible. Pile the soil on the opposite side of the trenches.

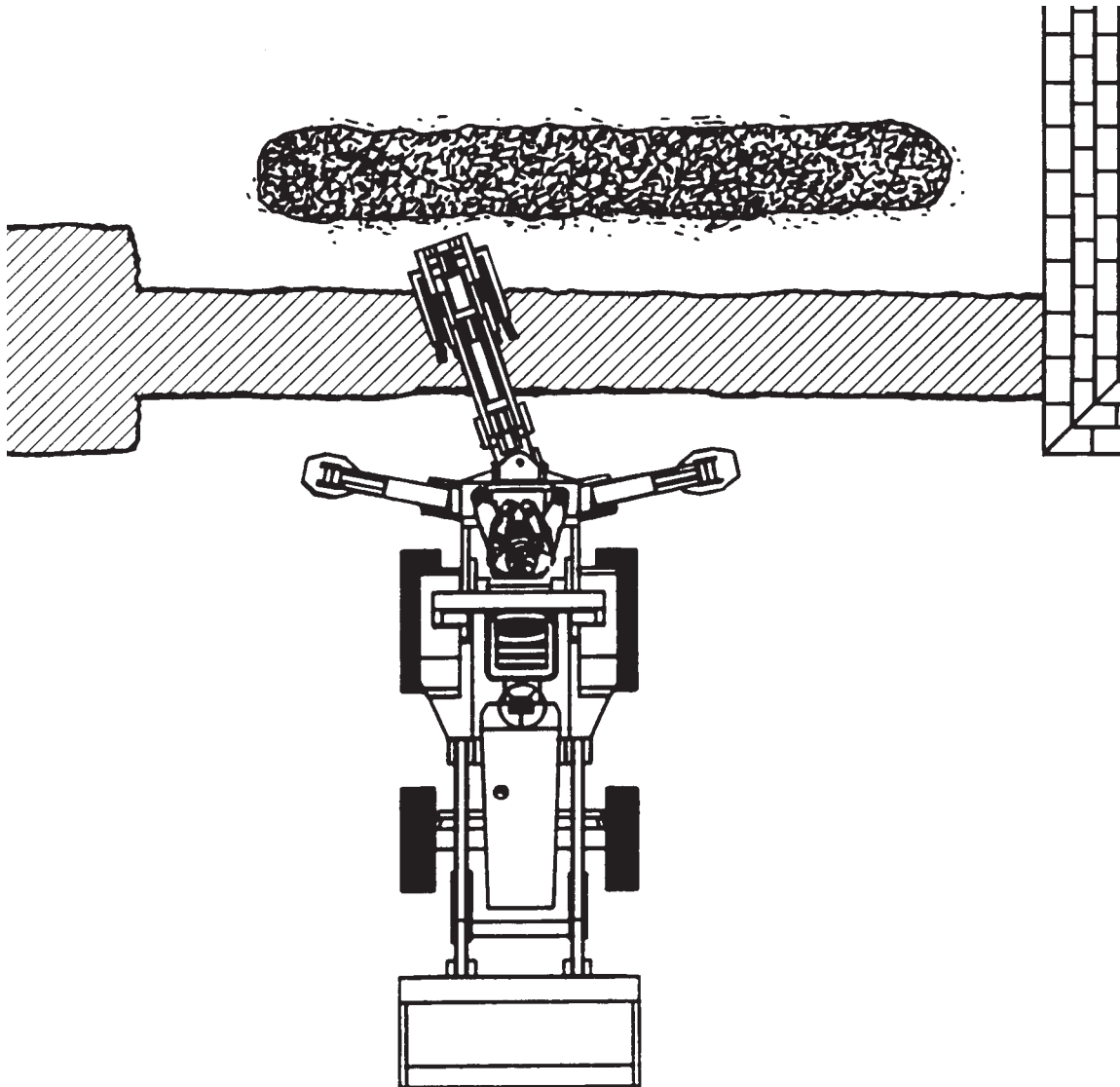

Position the unit forward so the two trenches can be connected. Pile the spoil on the opposite side of the trench.

OPERATING INSTRUCTIONS

OPERATING TECHNIQUES

ATTACHMENT TYPE BACKHOES

EXCAVATING ON SLOPES

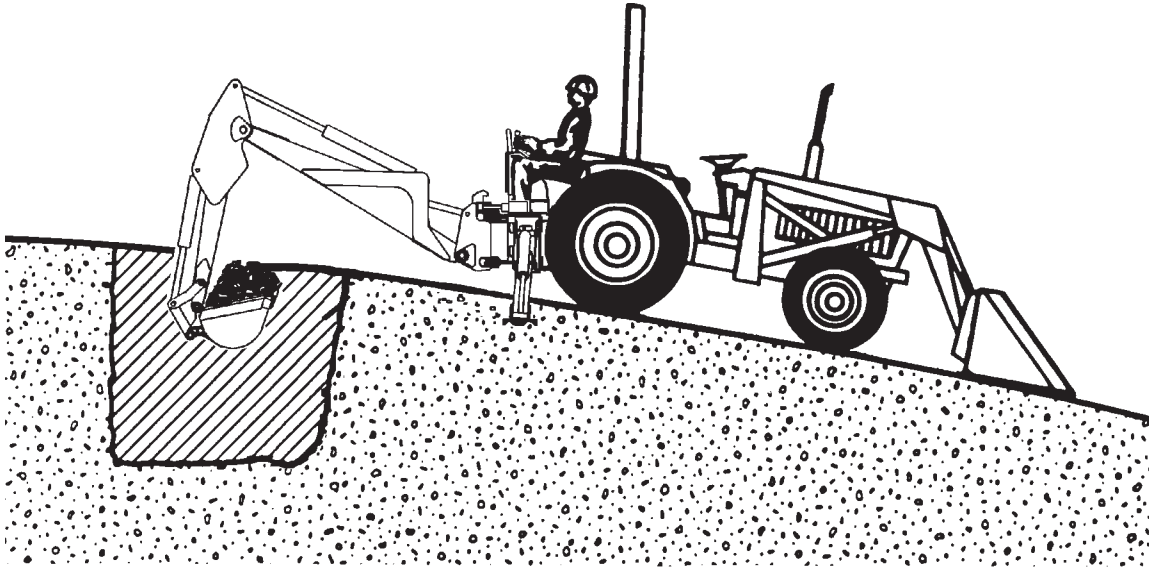

When digging on slopes always face the backhoe upgrade whenever possible. It may be necessary to cut a level surface in the hill for the backhoe to sit in when operating on slopes. This will allow the backhoe to sit level for digging the main excavation. Pile the spoil from the surface downhill. When digging the main excavation, pile the spoil uphill.

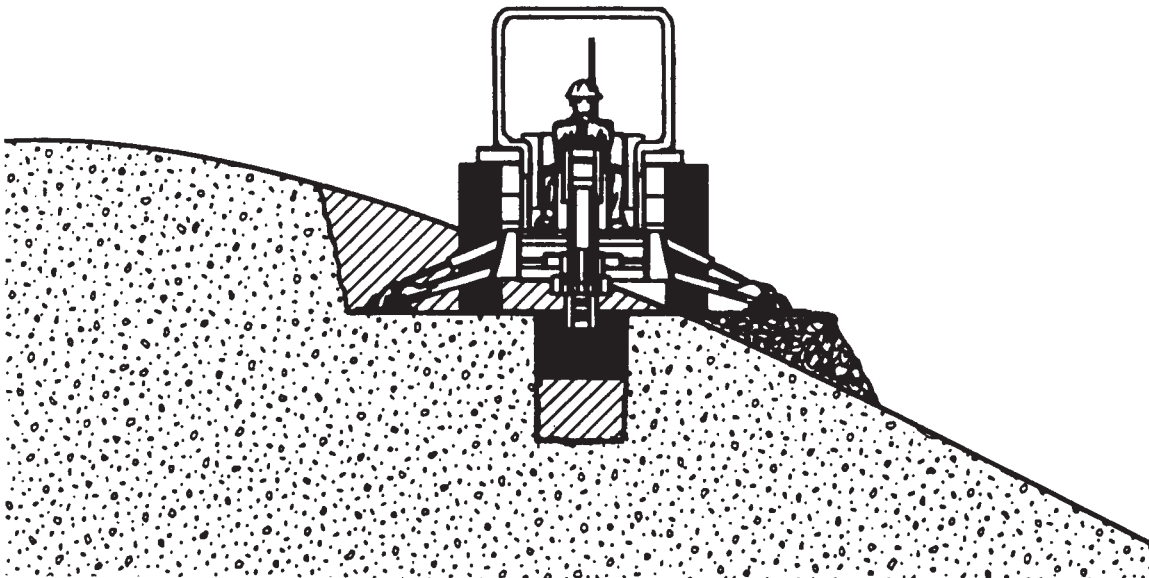

OPERATING INSTRUCTIONS

OPERATING TECHNIQUES

ATTACHMENT TYPE BACKHOES

PIPELINE LEAK REPAIR

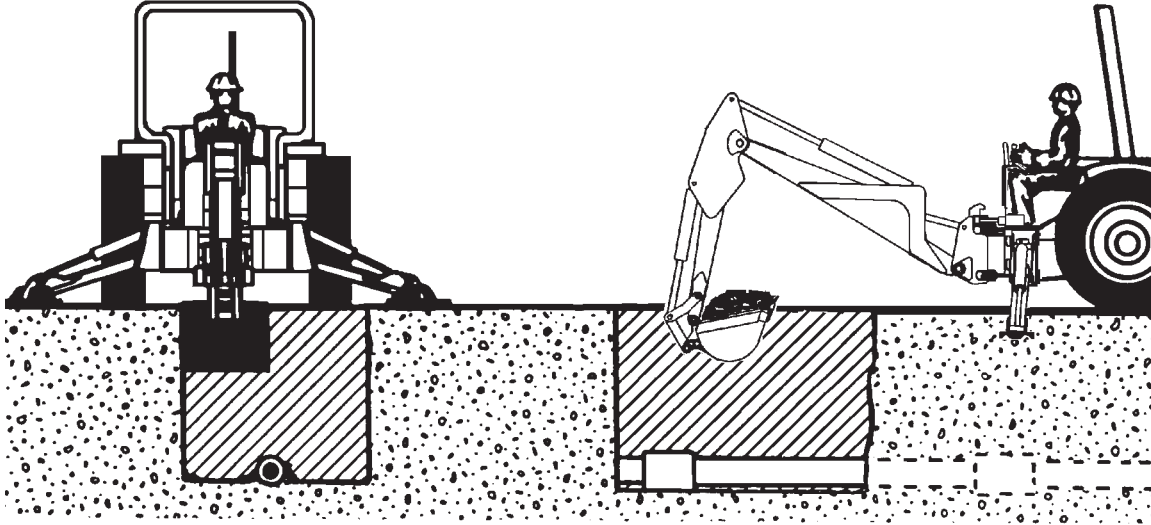

To check for pipeline leaks, start by digging a bellhole about six feet wide and ten feet long. Then, dig lengthwise along the pipeline to locate the leak. Once the leak is located, position the unit to dig at grade level on both sides of the pipeline. If a section of pipe is to be replaced, strip the soil from both ends of the bellhole. Enlarge the hole enough to allow the workmen adequate working space in the leak area.

DIGGING STRAIGHT WALL SHALLOW BASEMENTS

Begin at one corner, and remove as much material as possible to grade level. Reset the unit forward and continue digging to the grade level. Progress around the edge of the basement, finishing each corner as you come to it.

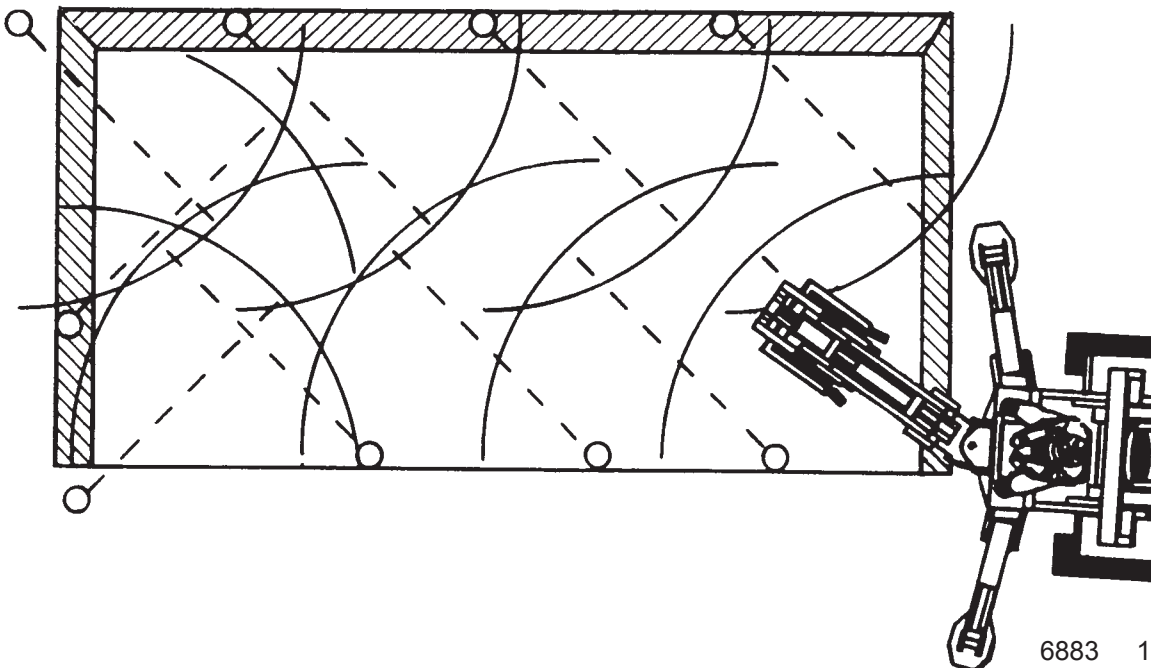

6883 1-25-06-2

OPERATING INSTRUCTIONS

OPERATING TECHNIQUES ATTACHMENT TYPE BACKHOES

MISCELLANEOUS - BACKFILLING

To backfill an excavation, lower the extended bucket into the spoil pile. Curl the bucket and lift it clear of the spoil pile. Swing the bucket to the excavation and extend the bucket. Return the bucket to the spoil pile and continue the cycle until the job is completed.

IMPORTANT: Do not backfill by using the swing circuit and dragging the bucket sideways. Doing so could cause damage to the dipper, boom, and swing cylinders or main-frame.

IMPORTANT: Avoid constant jarring or hammering contact between the spoil pile and the loaded bucket as this may cause premature wear to the backhoe pins and bushings.

MISCELLANEOUS - EXCAVATING BY A WALL

To excavate by a wall, where the wall will interfere with the stabilizer placement, move the backhoe in at an angle to the wall. Concentrate on getting the swing pin as close to the wall as possible while leaving enough swing arc left to dump the spoil.

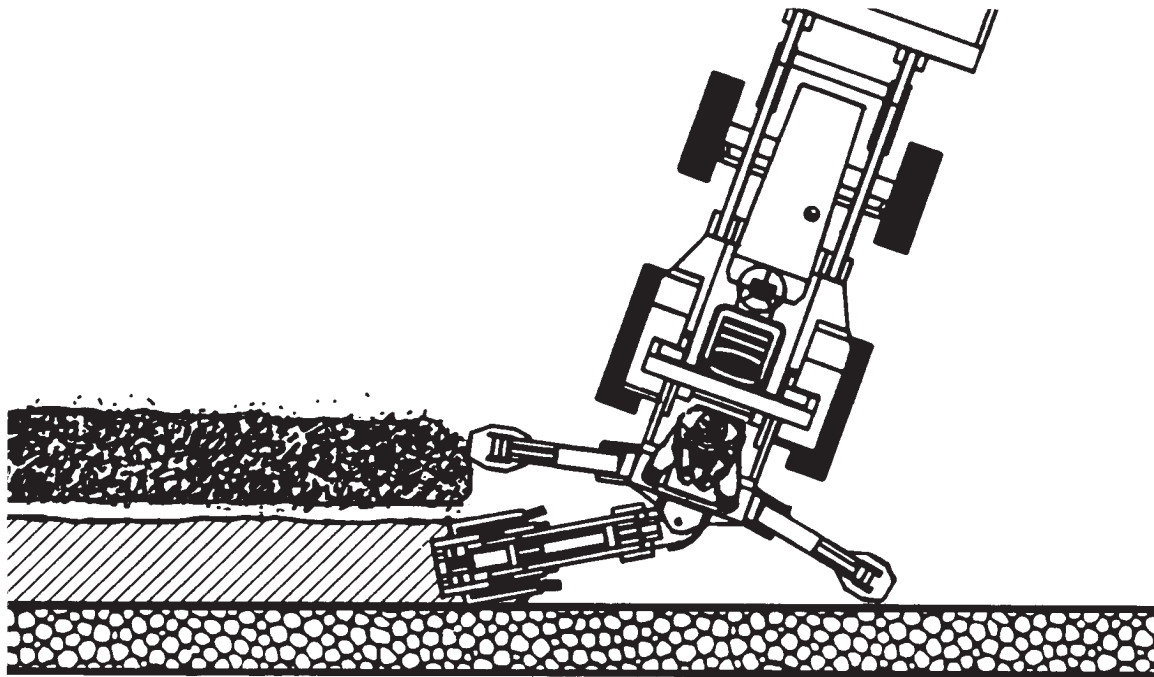

MISCELLANEOUS - HARD GROUND OPERATION

When digging in hard ground, it may be necessary to decrease the bucket angle of entry to the point where the back of the bucket almost contacts the ground. It may also be necessary to apply downward pressure with the boom on the bucket.

OPERATING INSTRUCTIONS

TRANSPORTING

GENERAL INFORMATION

Follow the simple steps listed below when preparing the backhoe for transportation between work sites. Read and follow the safety precautions for backhoe transporting listed in safety section of this manual before moving the backhoe.

1. Before transporting the backhoe, raise the boom, dipper, and bucket to the transporting position.
2. Engage the swing lock (if so equipped) by pushing down and to the left on the red swing lock ball handle.
3. Engage the boom lock by moving the boom lock handle to the left/down therefore locking the boom to the swing post in the transporting position.
4. Raise all stabilizers.

CAUTION! Be sure to install a **SMV (Slow Moving Vehicle)** sign on the backhoe dipper before attempting to transport the backhoe.



When transporting the backhoe on a road or highway at night or during the day, use accessory lights and devices for adequate warning to the operators of other vehicles. In this regard, check local government regulations.

Always drive slowly over uneven terrain to avoid tipping the backhoe.

LUBRICATION

509 & 511 BACKHOE

GENERAL INFORMATION

Economical and efficient operation of any machine is dependent upon regular and proper lubrication of all moving parts with a quality lubricant. Neglect leads to reduced efficiency, heavy draft, wear, breakdown, and needless replacement parts.

All parts provided with grease fittings should be lubricated as indicated. If any grease fittings are missing, replace them immediately. Clean all fittings thoroughly before using grease gun.

IMPORTANT: Avoid excessive greasing. Dirt collects on exposed grease and greatly increases wear. After greasing, wipe off excessive grease from fittings.

LUBRICATION SYMBOLS

The following symbol is used on the lubrication diagram printed on the following page. It is reproduced here with its meaning for your convenience.



Lubricate daily or every 8 hours of operation, whichever comes first, with SAE Multi-Purpose Lubricant or an equivalent SAE Multi Purpose type grease.

CAUTION! Shut off vehicle engine before lubricating equipment.



LUBRICATION

509 & 511 BACKHOE

BACKHOE LUBRICATION DIAGRAM

The following diagram is provided to help you locate all the points on your backhoe that need lubricating. Be sure to follow the lubrication intervals as noted by the lubrication symbols used on this page. Always replace any missing grease fittings as soon as possible.

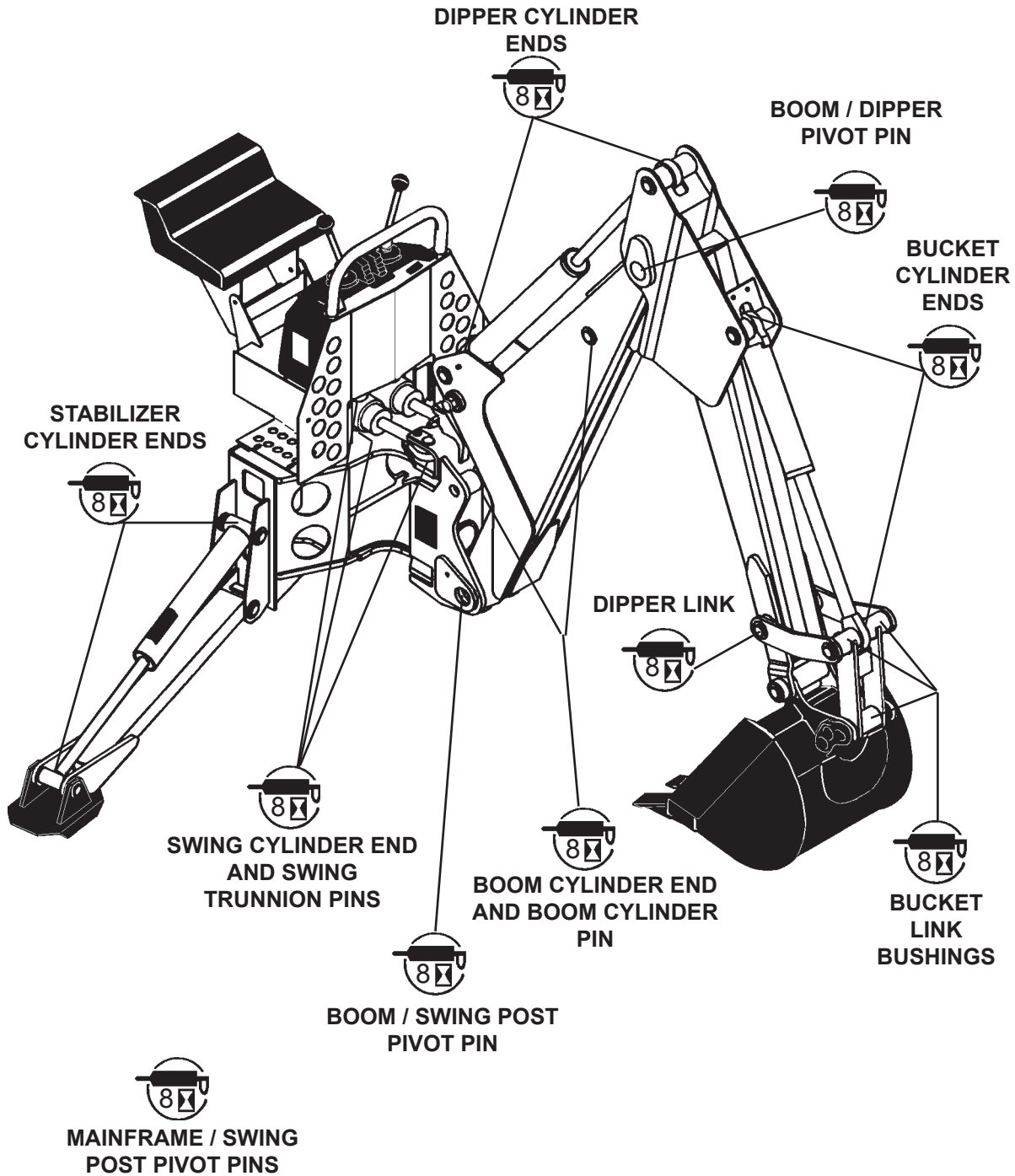

MAINTENANCE AND SERVICE

GENERAL INFORMATION

Regular maintenance is the key to long equipment life and safe operation. Maintenance requirements have been reduced to an absolute minimum. However, it is very important that these maintenance functions be performed as described below.

EVERY 8 HOURS OF OPERATION

Grease all swivel points (ram and base end of all cylinders) thoroughly. Excessive wear and even mechanical damage to pins and cylinders can result from inadequate lubrication. Use a multi-purpose grease.

Lubricate all grease fittings with a multi-purpose grease. For grease locations, refer to the diagram in the lubrication section of this manual.

EVERY 40 HOURS OF OPERATION

Check hydraulic reservoir fluid level. If oil is low, check all lines, fittings, and control valve for signs of leakage.

IMPORTANT: Hydraulic fluid level should be checked with backhoe in transport position.

WARNING! Escaping hydraulic/diesel fluid under pressure can penetrate the skin causing serious injury.



DO NOT use your hand to check for leaks. Use a piece of cardboard or paper to search for leaks.

Stop engine and relieve pressure before connecting or disconnecting lines.

Tighten all connections before starting engine or pressurizing lines.

If any hydraulic/diesel fluid is injected into the skin, obtain medical attention immediately or gangrene or other serious injury will result.

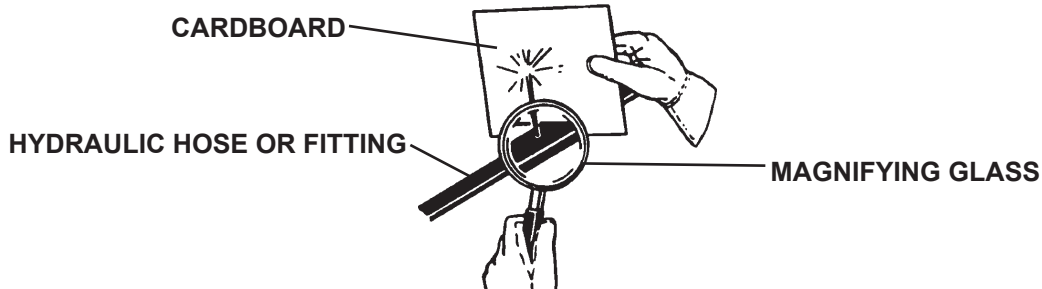

Physically check all pins, bushings, cotter pins, nuts, etc., for signs of wear or loose fit. Tighten as required, replacing where necessary. (Bolts and pins may vibrate loose during operation.) Clean equipment of all dirt, oil, and excess grease. This will assist you in making visual inspections and help avoid overlooking worn or damaged components.

MAINTENANCE AND SERVICE

CONTROL VALVE

The hydraulic control valve maintenance is normally limited to replacement of O-ring seals, cleaning and the replacement of valve sections (Gresen) or relief valve cartridges.

The most common cause of premature wear and malfunctioning of hydraulic system components is the ingress of contaminants and incorrect high pressure inlet and low pressure return connections (cavitation).

Observe a high standard of cleanliness when doing valve maintenance.

REPLACING BUCKET TOOTH POINTS

The bucket teeth are self-sharpening and require little attention: however, the points on the bucket teeth shanks can be replaced when they become worn or broken.

A tooth point can be removed from the welded tooth shank by removing the roll pin and sliding the tooth point off of the shank. Install the new point and secure in place with the roll pin.

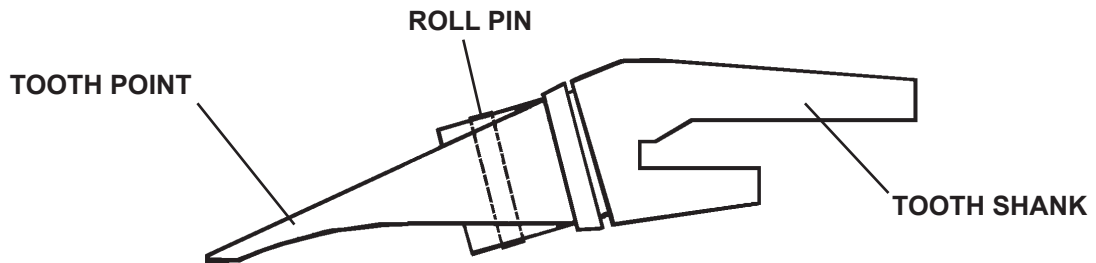

CHANGING BUCKETS

The bucket is connected to the dipper and bucket link with two cotter pin style pins. To change buckets, remove the cotter pins and washers and then remove the old bucket and position the new bucket in its place. Install the pivot pins and secure with washers and cotter pins. Lubricate all bucket and bucket link grease fittings before operating.

NOTE: Dipper Link must be installed with the pin containing the grease zerks at the dipper end and angled as shown in the diagram.

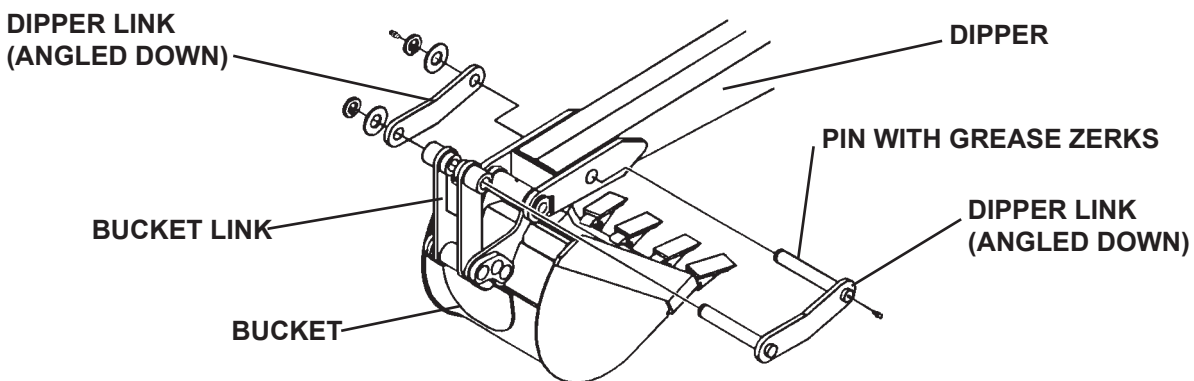

MAINTENANCE AND SERVICE

DIGGING POSITIONS

Power dig buckets may be installed in any one of three different digging positions. By using the different pairs of bucket link mounting holes, digging characteristics of the backhoe can be changed to suit the working conditions.

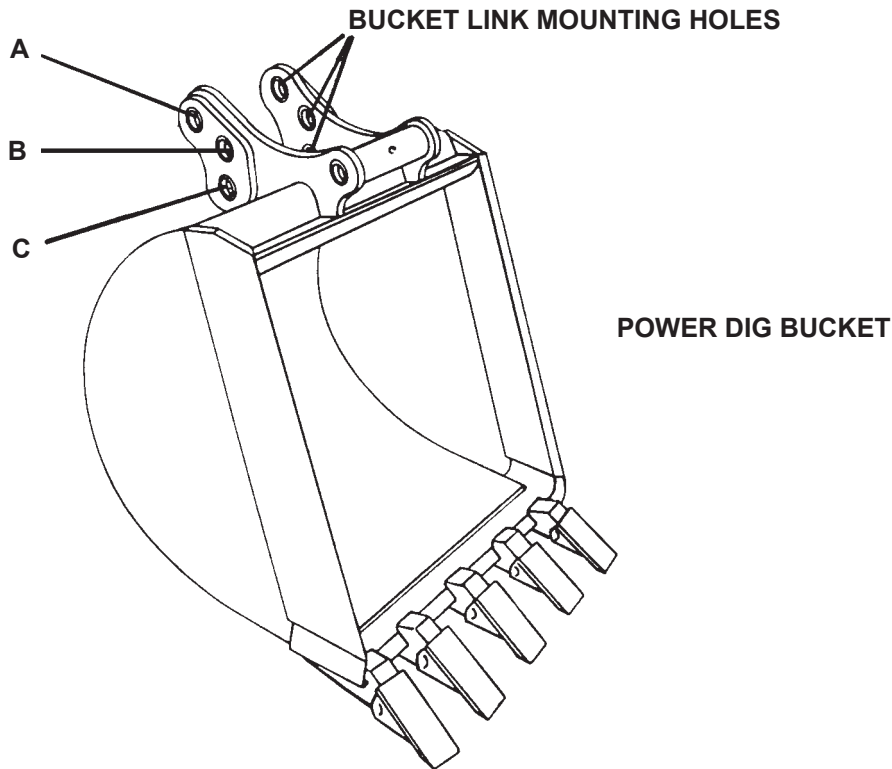

"A" Position A is the power digging position for maximum digging force in hard ground. This position will give you a 20 percent increase in digging power over the standard position.

"B" Position B is the truck loading position. It gives greater ease of spoil removal with a higher dump height than the standard or power dig position.

"C" Position C is the standard digging position. When the bucket is mounted in this position, it will have 180° of rotation.

Digging positions are easily changed by removing the bucket link pivot pin from the bucket. Realign the hole in the bucket link with the correct holes in the bucket for the desired results. Install the pivot pin and secure it with the original washers and cotter pins and you're ready to go.

A special bell hole link is required to achieve a true bell hole position. This part is available from your dealer.

MAINTENANCE

HOSE ROUTING - 509 511 BACKHOE

GENERAL INFORMATION

The purpose of this page is to show the hydraulic hose routing between the backhoe control valve and the various backhoe hydraulic cylinders. This information is helpful when trouble shooting cylinder and control valve related problems. Simply match the number of the hydraulic cylinder port (shown in the bottom diagram), to the corresponding number on the backhoe control valve (shown in the top diagram).

NOTE: The fittings on the hydraulic cylinders have been altered for clarity purposes. This will assist you in distinguishing between the rod end and the barrel end of the various hydraulic cylinders.

BACKHOE CONTROL VALVE

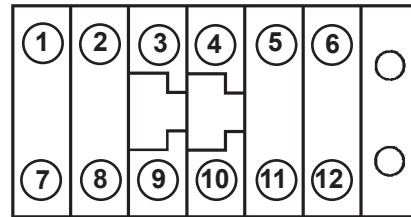

BACKHOE CYLINDERS

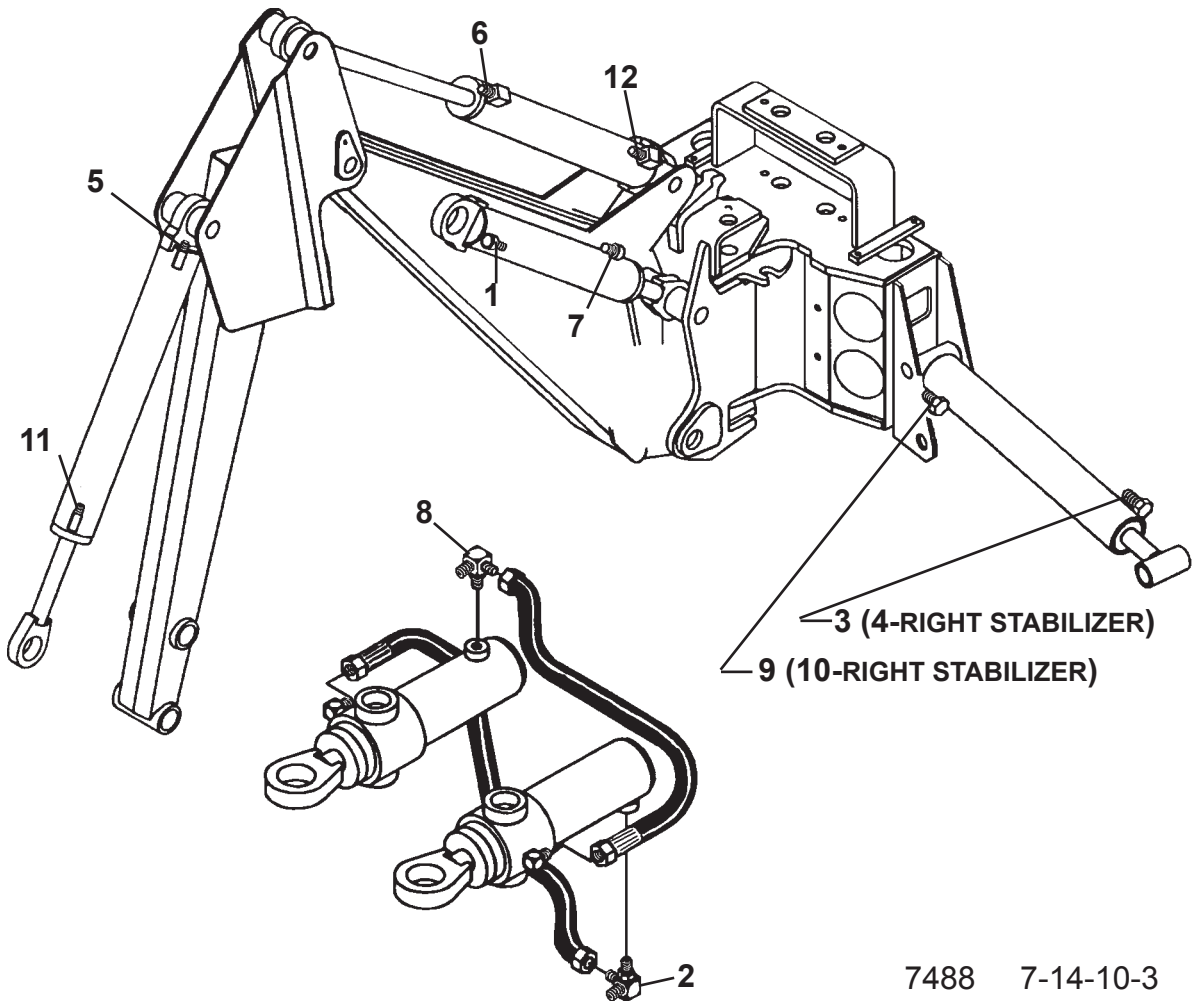

7488 7-14-10-3

MAINTENANCE AND SERVICE

CYLINDER SEAL REPLACEMENT

The following information is provided to assist you in the event you should need to repair or rebuild a hydraulic cylinder. When working on hydraulic cylinders, make sure that the work area and tools are clean and free of dirt to prevent contamination of the hydraulic system and damage to the hydraulic cylinders. Always protect the active part of the cylinder rod (the chrome section). Nicks or scratches on the surface of the rod could result in cylinder failure. Clean all parts thoroughly with a cleaning solvent before reassembly.

DISASSEMBLY PROCEDURE

IMPORTANT: Do not contact the active surface of the cylinder rod with the vise. Damage to the rod could result.

THREADED TYPE GLAND

1. Rotate the gland with a spanner wrench counterclockwise until the gland is free of the cylinder tube.
2. Pull the cylinder rod from the cylinder tube and inspect the piston and the bore of the cylinder tube for deep scratches or galling. If damaged, the piston AND the cylinder tube must be replaced.

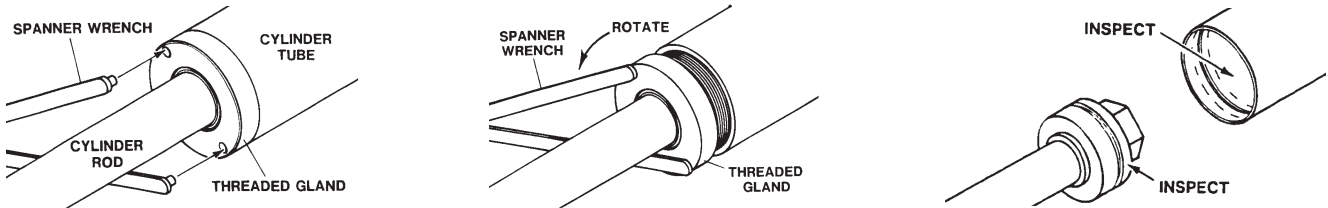

3. Remove the hex nut, piston, flat washer or spacer tube (if so equipped), and gland from the cylinder rod. If the cylinder rod is rusty, scratched, or bent, it must be replaced.
4. Remove and discard all the old seals.



ASSEMBLY PROCEDURE

IMPORTANT: Replace all seals even if they do not appear to be damaged. Failure to replace all seals may result in premature cylinder failure. **NOTE:** Seal kits will service most cylinders of similar bore size and rod diameter.

1. Install the cylinder rod seal in the gland first. Be careful not to damage the seal in the process, as it is somewhat difficult to install.

NOTE: A special installation tool (Part #65349) is available to help with installing the seal. Simply fit the end of the tool over the seal so that the large prong of the tool is on the outside of the seal, and the two smaller prongs on the inside. The lip of the seal should be facing towards the tool. Rotate the handles on the tool around to wrap the seal around the end of the tool.

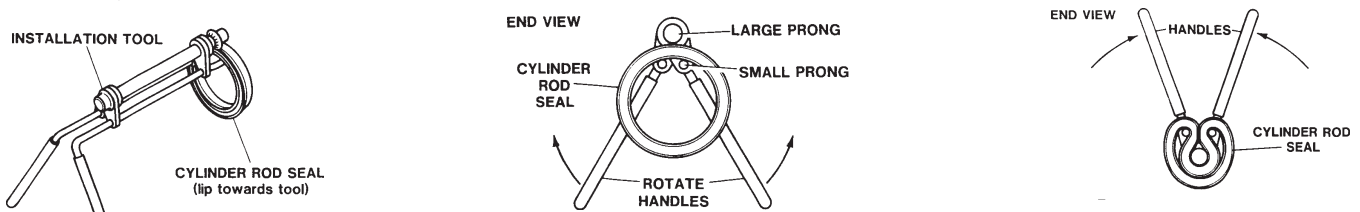

10356 10-13-05

MAINTENANCE AND SERVICE

Now insert the seal into the gland from the inner end. Position the seal in its groove, and release and remove the tool. Press the seal into its seat the rest of the way by hand.

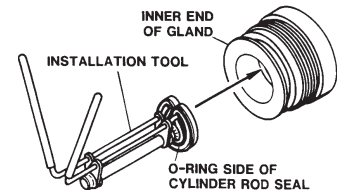

- Install the new piston ring, rod wiper, O-rings and backup washers, if applicable, on the piston.

Be careful not to damage the seals. Caution must be used when installing the piston ring. The ring must be stretched carefully over the piston with a smooth, round, pointed tool.

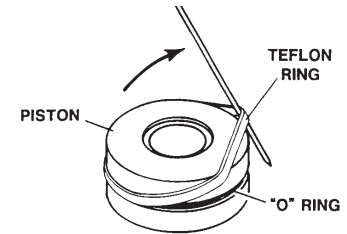

- After installing the rod seal inside the gland, as shown in step #1, install the external seal.

NOTE: Threaded glands may have been equipped with a separate O-ring and backup washer system or a polypak (all in one) type seal. Current seal kits contain a polypak (all in one) type seal to replace the discarded seal types on ALL THREADED GLANDS.

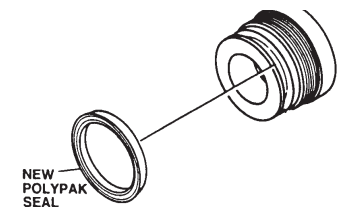

- Slide the gland onto the cylinder rod, being careful not to damage the rod wiper. Then install the spacer, or flat washer (if so equipped), small o-ring, piston, and hex nut onto the end of the cylinder rod.
- Secure the cylinder rod (mounting end) in a vise with a support at its center. Torque the nut to the amount shown for the thread diameter of the cylinder rod (see chart).

Thread Diameter	POUNDS - FEET
7/8"	150-200
*1"	230-325
1-1/8"	350-480
1-1/4"	490-670
1-3/8"	670-900
* 1" Thread Diameter WITH 1.25" Rod Diameter Min. 230 ft. lbs. Max. 250 ft. lbs.	

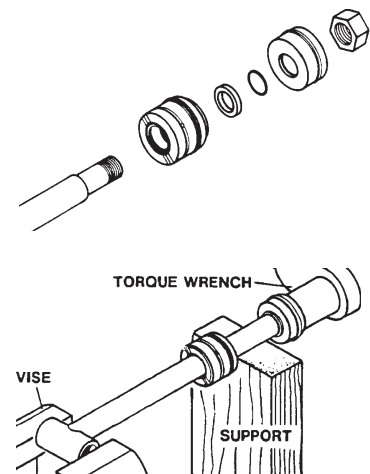

IMPORTANT: Do not contact the active surface of the cylinder rod with the vise. Damage to the rod could result.

- Apply a lubricant (such as Lubriplate #105) to the piston and teflon ring. Insert the cylinder rod assembly into the cylinder tube.

IMPORTANT: Ensure that the piston ring fits squarely into the cylinder tube and piston groove, otherwise the ring may be damaged and a leak will occur.

- Use a spanner wrench to rotate the gland clockwise into the cylinder. Continue to rotate the gland with the spanner wrench until it is tight.

WARNING! Cylinders serviced in the field are to be tested for leakage prior to the attachment being placed in work. Failure to test rebuilt cylinders could result in damage to the cylinder and/or the attachment, cause severe personal injury or even death.



MAINTENANCE AND SERVICE

BACKHOE STORAGE

To prepare the backhoe for storage, first wash off all dirt and grime from the unit. Coat the exposed portions of the cylinder rods with grease. Lubricate all grease fittings. Make sure the backhoe hydraulic system is properly sealed against contaminants entering the unit. When storing the backhoe, place the unit in a clean dry place with a cover over the unit if possible.

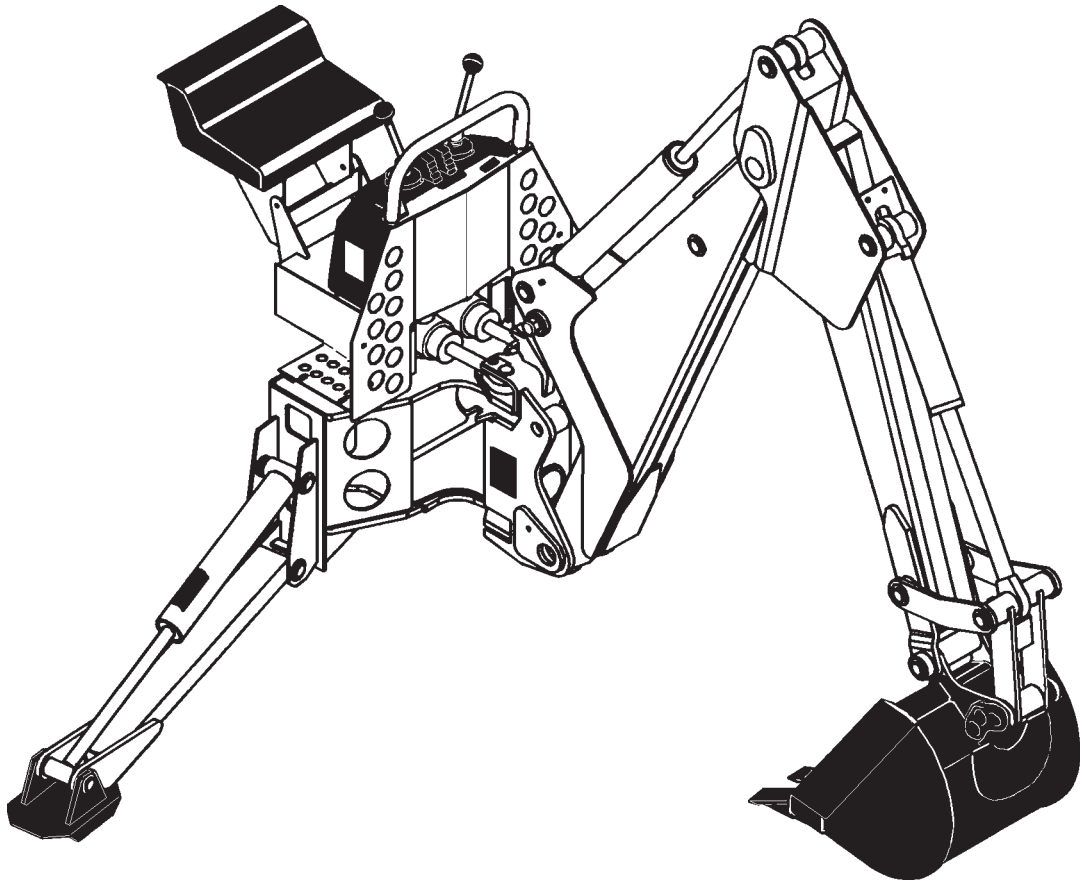

TROUBLESHOOTING

PROBLEM	POSSIBLE CAUSE	REMEDY
Backhoe fails to lift or swing	Low oil supply	Add oil
	Improper hose hookup	Check hydraulic diagram; reinstall properly
	Worn control valve section	Replace section
	Pump damaged or worn	Replace pump
	Broken hydraulic line	Check for leaks and replace line
	Jammed swing linkage	Remove interference
	Bent cylinder rod	Replace or repair cylinder
	Swing speed control completely closed	Open swing speed control valve
Backhoe lifting or swinging too slowly	Cold oil	Warm oil with engine at idle speed
	Engine speed too slow	Open throttle
	Oil leaking past control valve	Replace or repair worn section
	Oil too heavy	Use recommended oil
	Pump damaged or worn	Replace or repair pump
	Oil leaking past cylinder packings	Replace packings
	Dirty oil filter	Replace filter
	Faulty relief valve	Clean or replace
	Incorrect restrictors in valve	Check restrictor orifice size with those shown on valve assembly page

TROUBLESHOOTING

PROBLEM	POSSIBLE CAUSE	REMEDY
Backhoe fails to hold up load	Broken or leaking lines	Replace broken hose and check for leaks
	Dirty oil	Drain and refill oil, replace filter
	Oil leaking past cylinder packings	Replace packings
	Oil leaking past control valve	Replace or repair worn section
	Faulty relief valve	Clean or replace
Oil heating	Dirty oil	Drain and refill oil, replace filter
	Air entering suction line to pump	Eliminate leaks
	Partially plugged inlet filter	Clean filter element
	Control valve held open too long	Return control to neutral position when not in use
	Worn pump	Replace pump
	Relief valve set too low	Set valve correctly
	Oil too light in hot weather	Use recommended oil
	Engine running too fast	Reduce throttle
	Damaged oil lines	Replace damaged lines
	Poor operating technique causing excessive oil flow over relief valve	Learn smooth operating methods
Damaged O-rings between valve sections (Gresen)	Repair control valve	

TROUBLESHOOTING

PROBLEM	POSSIBLE CAUSE	REMEDY
External leakage	Control valve tie bolts loose (Gresen)	Torque bolts to 20 ft. lbs.
	Damaged O-rings between valve sections (Gresen)	Repair control valve
	Damaged O-rings on valve spools	Repair control valve
	Cylinder seals damaged	Repair cylinder
	Damaged O-rings on valve drop check	Repair control valve
	Broken oil lines	Replace hose and check for leaks
Swing cylinder malfunctioning	Oil leaking past packing or seals	Replace packing or seals
	Faulty relief valve	Clean or replace
Control valve sticking or working hard	Dirty valve	Clean valve
	Scored bore or bent spool	Inspect and replace spool, valve section (Gresen) or entire valve
	Control linkage misaligned	Correct misalignment
	Control valve tie bolts too tight	Tighten bolts only to 20 ft.lbs.
	Return spring binding broken	Replace spring
	Foreign matter in spool bore	Clean valve



BOLT TORQUE SPECIFICATIONS

GENERAL TORQUE SPECIFICATION TABLES

Use the following charts when determining bolt torque specifications when special torques are not given. Always use grade 5 or better when replacing bolts.



SAE BOLT TORQUE SPECIFICATIONS

NOTE: The following torque values are for use with extreme pressure lubricants, plating or hard washer applications. Increase torque 15% when using hardware that is unplated and either dry or lubricated with engine oil.

Bolt Size		SAE GRADE 5 TORQUE				SAE GRADE 8 TORQUE				Bolt head identification marks as per grade. NOTE: Manufacturing Marks Will Vary
		Pounds Feet		Newton-Meters		Pounds Feet		Newton-Meters		
Inches	Millimeters	UNC	UNF	UNC	UNF	UNC	UNF	UNC	UNF	
1/4	6.35	8	9	11	12	10	13	14	18	<p>GRADE 2</p>  <p>GRADE 5</p>  <p>GRADE 8</p> 
5/16	7.94	14	17	19	23	20	25	27	34	
3/8	9.53	30	36	41	49	38	46	52	62	
7/16	11.11	46	54	62	73	60	71	81	96	
1/2	12.70	68	82	92	111	94	112	127	152	
9/16	14.29	94	112	127	152	136	163	184	221	
5/8	15.88	128	153	174	207	187	224	254	304	
3/4	19.05	230	275	312	373	323	395	438	536	
7/8	22.23	340	408	461	553	510	612	691	830	
1	25.40	493	592	668	803	765	918	1037	1245	
1-1/8	25.58	680	748	922	1014	1088	1224	1475	1660	
1-1/4	31.75	952	1054	1291	1429	1547	1700	2097	2305	
1-3/8	34.93	1241	1428	1683	1936	2023	2312	2743	3135	
1-1/2	38.10	1649	1870	2236	2535	2686	3026	3642	4103	

METRIC BOLT TORQUE SPECIFICATIONS

NOTE: The following torque values are for use with metric hardware that is unplated and either dry or lubricated with engine oil. Reduce torque 15% when using hardware that has extreme pressure lubricants, plating or hard washer applications.

Bolt head identification marks as per grade.		
		

Size of Bolt	Grade No.	Pitch (mm)	Pounds Feet	Newton-Meters	Pitch (mm)	Pounds Feet	Newton-Meters
M6	5.6	1.0	3.6-5.8	4.9-7.9	-	-	-
	8.8		5.8-4	7.9-12.7		-	-
	10.9		7.2-10	9.8-13.6		-	-
M8	5.6	1.25	7.2-14	9.8-19	1.0	12-17	16.3-23
	8.8		17-22	23-29.8		19-27	25.7-36.6
	10.9		20-26	27.1-35.2		22-31	29.8-42
M10	5.6	1.5	20-25	27.1-33.9	1.25	20-29	27.1-39.3
	8.8		34-40	46.1-54.2		35-47	47.4-63.7
	10.9		38-46	51.5-62.3		40-52	54.2-70.5
M12	5.6	1.75	28-34	37.9-46.1	1.25	31-41	42-55.6
	8.8		51-59	69.1-79.9		56-68	75.9-92.1
	10.9		57-66	77.2-89.4		62-75	84-101.6
M14	5.6	2.0	49-56	66.4-75.9	1.5	52-64	70.5-86.7
	8.8		81-93	109.8-126		90-106	122-143.6
	10.9		96-109	130.1-147.7		107-124	145-168
M16	5.6	2.0	67-77	90.8-104.3	1.5	69-83	93.5-112.5
	8.8		116-130	157.2-176.2		120-138	162.6-187
	10.9		129-145	174.8-196.5		140-158	189.7-214.1
M18	5.6	2.0	88-100	119.2-136	1.5	100-117	136-158.5
	8.8		150-168	203.3-227.6		177-199	239.8-269.6
	10.9		175-194	237.1-262.9		202-231	273.7-313
M20	5.6	2.5	108-130	146.3-176.2	1.5	132-150	178.9-203.3
	8.8		186-205	252-277.8		206-242	279.1-327.9
	10.9		213-249	288.6-337.4		246-289	333.3-391.6

SPECIFICATIONS

509 AND 511 POWER BACKHOES

BACKHOE DIMENSIONS

SPECIFICATIONS AND DESIGN ARE SUBJECT TO CHANGE WITHOUT NOTICE AND WITHOUT LIABILITY THEREFORE. WHENEVER APPLICABLE SPECIFICATIONS ARE IN ACCORDANCE WITH SAE STANDARDS.

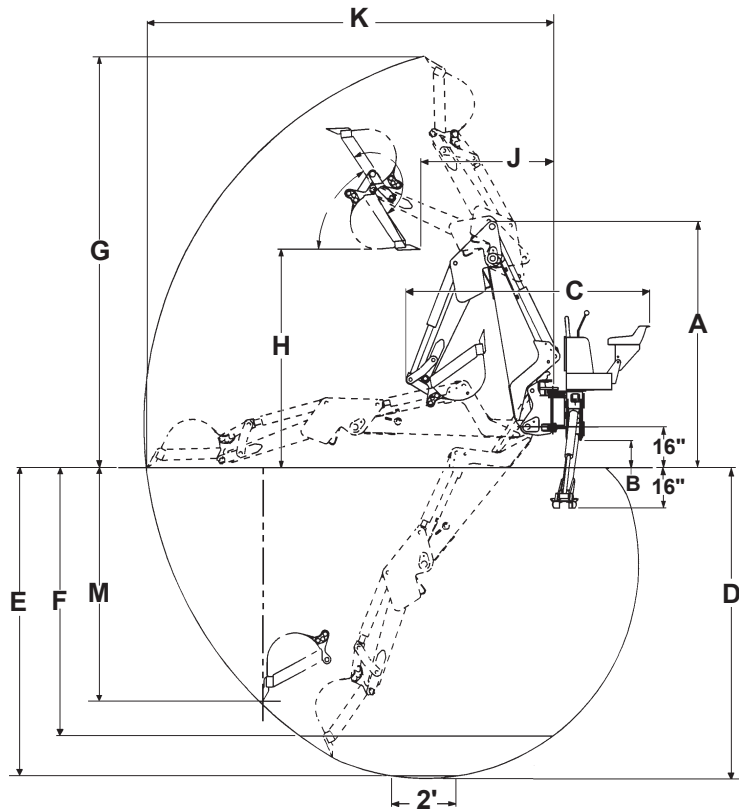

BACKHOE SPECIFICATIONS TABLE	509	511
TRANSPORT		
A Transport Height (with boom fully retracted).....	7'9"	8'10"
Transport Width (with stabilizers up).....	5'0"	5'0"
B Ground Clearance.....	11"	11"
C Overall Length.....	7'7"	7'9"
Boom Pivot Height	16"	16"
Operating Weight w/12" Bucket	1425#	1594#
OPERATIONAL		
D Digging Depth Maximum.....	9'8"	11'1"
E Digging Depth (2 Ft.) Flat Bottom	9'7"	11'0"
F Digging Depth (8 Ft.) Flat Bottom	8'3"	9'11"
G Overall Operating Height - Fully Raised.....	12'10"	14'5"
H Loading Height.....	6'10"	8'0"
J Loading Reach.....	4'2"	5'0"
K Reach From Swing Post.....	12'9"	14'5"
L Bucket Rotation	180°	180°
Swing Arc	180°	180°
M Straight Wall Digging Depth	7'3"	8'2"
Stabilizer Spread Operating Position	7'11"	7'11"
Stabilizer Down Below Grade.....	16"	16"
System Relief Valve Setting.....	2500 PSI	2500PSI
Digging Force - Bucket Cylinder.....	5676#	5676#
Digging Force - Dipper Cylinder	2754#	3056#

SPECIFICATIONS

CYLINDER AND BUCKET SPECIFICATIONS 509 & 511 POWER BACKHOE

CYLINDER SPECIFICATION TABLE

CYLINDER	509	511		
BUCKET CYLINDER				
Cylinder #	82477	82477		
Bore	3.00"	3.00"		
Stroke	18.38"	18.38"		
Rod Diameter	2.00"	2.00"		
DIPPER CYLINDER				
Cylinder #	86236	87029		
Bore	3.00"	3.00"		
Stroke	21.38"	27.00"		
Rod Diameter	1.75"	1.75"		
BOOM CYLINDER				
Cylinder #	86231	82625		
Bore	2.75"	3.00"		
Stroke	24.83"	24.83"		
Rod Diameter	1.50"	1.50"		
SWING CYLINDER				
Cylinder #	81827	81827		
Bore	2.50"	2.50"		
Stroke	7.65"	7.65"		
Rod Diameter	1.25"	1.25"		
STABILIZER CYLINDER				
Cylinder #	86605	86605		
Bore	2.50"	2.50"		
Stroke	16.43"	16.43"		
Rod Diameter	1.50"	1.50"		
POWER DIG BUCKETS AND CAPACITIES				
<u>Bucket Size</u>	<u>Struck Cap. Ft.³</u>	<u>Heaped Cap. Ft.³</u>	<u>Weight Lbs.</u>	<u>Number Of Teeth</u>
Standard 12"	1.43	1.83	125	3
Standard 16"	1.98	2.56	139	4
Standard 18"	2.25	2.98	147	4
Standard 20"	2.52	3.40	153	4
Standard 24"	3.07	4.32	170	5
Severe Duty 12"	1.43	1.83	140	3
Severe Duty 16"	1.98	2.56	154	4
Severe Duty 18"	2.25	2.98	162	4
Severe Duty 20"	2.52	3.40	168	4
Severe Duty 24"	3.07	4.32	185	4

7491 7-14-10-3

BACKHOE CHECKLIST

FOR USE WITH BACKHOES AND BACKHOE MOUNTING KITS

DEALER RESPONSIBILITY:

The following check list is to be completed by the equipment dealer. This checklist is to be completed by the dealer at time of delivery. When purchasing a mounting kit for an existing backhoe it is the equipment dealers responsibility to review this checklist with the customer and instruct them to check each item at time of installation onto their prime mover.

BACKHOE:

1. _____ Check and lubricate backhoe. See "Lubrication Section" in Operator's Manual.
2. _____ Visually inspect the backhoe for bent, loose, cracked, damaged or missing parts or any other irregularities prior to operation.
3. _____ Verify backhoe control lever function and direction of operation are in accordance with the control lever decals.
4. _____ Run cylinders through their full cycle to purge any air from the system. Recheck hydraulic system for correct hydraulic fluid levels.
5. _____ Check all hydraulic connections for leaks and all hoses for proper positioning to reduce chafing and binding.
6. _____ Check prime mover system relief valve pressure and compare and adjust to recommended operating pressure listed in the "Specifications Section" of the Operator's Manual.
7. _____ Make sure decals are not damaged or missing and are in their right location. See "Decals Section" of the Operator's Manual.
8. _____ Customer instructed to read and understand Operator's Manual before operating backhoe.
9. _____ Complete and return the manufacturers "Warranty Validation Form".

MOUNTING:

1. _____ Check backhoe, mounting, and prime mover to ensure they are all compatible.
2. _____ Check backhoe mounting bolts for tightness. Instruct owner to retighten after the first eight working hours, and after every forty working hour interval thereafter. See "Bolt Torque Specifications" in Operator's Manual.
3. _____ If customer is installing the mounts and mounting the backhoe to the prime mover, the dealer must review the proper mounting procedure and possible consequences of improper installation.
4. _____ Verify the owner is in possession of an operator's manual and instruct them to read and understand all safety and operating techniques.

OWNERS RESPONSIBILITY:

It is the owner's responsibility to make sure that the dealer has completed this checklist and instructed him/her on safe and proper operation of the backhoe. If installation instructions are unclear, bring backhoe, mounting and prime mover to the equipment dealership for proper installation.

Owner's Signature

Date

Dealership Signature

Date

**THIS PAGE
IS INTENTIONALLY
BLANK**

Limited Warranty

Except for the Excluded Products as described below, all new products are warranted to be free from defects in material and/or workmanship during the Warranty Period, in accordance with and subject to the terms and conditions of this Limited Warranty.

1. Excluded Products. The following products are excluded from this Limited Warranty:

(a) Any cable, part that engages with the ground (i.e. sprockets), digging chain, bearing, teeth, tamping and/or demolition head, blade cutting edge, pilot bit, auger teeth and broom brush that either constitutes or is part of a product.

(b) Any product, merchandise or component that, in the opinion of Paladin Light Construction¹, has been (i) misused; (ii) modified in any unauthorized manner; (iii) altered; (iv) damaged; (v) involved in an accident; or (vi) repaired using parts not obtained through Paladin Light Construction.

2. Warranty Period. The Limited Warranty is provided only to those defects that occur during the Warranty Period, which is the period that begins on the first to occur of: (i) the date of initial purchase by an end-user, (ii) the date the product is first leased or rented, or (iii) the date that is six (6) months after the date of shipment by Paladin Light Construction as evidenced by the invoiced shipment date (the "Commencement Date") and ends on the date that is twenty-four (24) months after the Commencement Date.

3. Terms and Conditions of Limited Warranty. The following terms and conditions apply to the Limited Warranty hereby provided:

(a) Option to Repair or Replace. Paladin Light Construction shall have the option to repair or replace the product.

(b) Timely Repair and Notice. In order to obtain the Limited Warranty, (i) the product must be repaired within thirty (30) days from the date of failure, and (ii) a claim under the warranty must be submitted to Paladin Light Construction in writing within thirty (30) days from the date of repair.

(c) Return of Defective Part or Product. If requested by Paladin Light Construction, the alleged defective part or product shall be shipped to Paladin Light Construction at its manufacturing facility or other location specified by Paladin Light Construction, with freight PRE-PAID by the claimant, to allow Paladin Light Construction to inspect the part or product.

Claims that fail to comply with any of the above terms and conditions shall be denied.

LIMITATIONS AND EXCLUSIONS.

THIS LIMITED WARRANTY IS IN LIEU OF ALL OTHER WARRANTIES, EXPRESS OR IMPLIED, INCLUDING WITHOUT LIMITATION THE WARRANTIES OF MERCHANTABILITY, FITNESS FOR A PARTICULAR PURPOSE AND ANY WARRANTY BASED ON A COURSE OF DEALING OR USAGE OF TRADE.

IN NO EVENT SHALL PALADIN LIGHT CONSTRUCTION BE LIABLE FOR CONSEQUENTIAL OR SPECIAL DAMAGES.

IN NO EVENT SHALL PALADIN LIGHT CONSTRUCTION BE LIABLE FOR ANY LOSS OR CLAIM IN AN AMOUNT IN EXCESS OF THE PURCHASE PRICE, OR, AT THE OPTION OF PALADIN LIGHT CONSTRUCTION, THE REPAIR OR REPLACEMENT, OF THE PARTICULAR PRODUCT ON WHICH ANY CLAIM OF LOSS OR DAMAGE IS BASED. THIS LIMITATION OF LIABILITY APPLIES IRRESPECTIVE OF WHETHER THE CLAIM IS BASED ON BREACH OF CONTRACT, BREACH OF WARRANTY, NEGLIGENCE OR OTHER CAUSE AND WHETHER THE ALLEGED DEFECT IS DISCOVERABLE OR LATENT.

¹Attachment Technologies Inc., a subsidiary of Paladin Brands Holding, Inc. (PBHI) is referred to herein as Paladin Light Construction.