



INSTRUCTIONS

-J00058

REV.04-21-2003

Kit Number 29982-81

22-AMP CHARGING SYSTEM

General

This kit fits all 1970 through 1988 motorcycles with Big Twin engines.

See the Service Parts illustration for kit contents.

WARNING

The rider's safety depends upon the correct installation of this kit. Follow the procedures listed in this instruction sheet and in the appropriate Service Manual.

If the procedures are not within your capabilities, or if you do not have the correct tools, have your Harley-Davidson Dealer perform the installation. Failure to follow instructions could result in death or serious injury.

NOTE

This instruction sheet references Service Manual information. A Service Manual for your model motorcycle is required for this installation and is available from any Harley-Davidson Dealer.

Installation

WARNING

To prevent accidental vehicle start-up, which could cause death or serious injury, disconnect negative (-) battery cable before proceeding. (00048a)

1. Refer to the Service Manual and follow the instructions given to remove the seat and disconnect the negative battery cable. Retain all seat mounting hardware.

2. Remove the original alternator and voltage regulator. Note the positions of any spacers or shims on the sprocket shaft during disassembly procedures.

Be sure to remove the original spacer that is positioned inboard of the rotor (if so equipped).

NOTE

The alternator rotor should be removed using rotor puller Part No. HD-95960-52B.

3. See the Service Parts illustration. Discard the original stator mounting screws (and the mounting screw locking plate, if so equipped). Install the new stator assembly (8) using the new mounting screws (1) from the kit. Tighten the screws to 30-40 in-lbs (3.4-4.5 Nm).

CAUTION

Do not install any combination of new style parts with old style parts. Mixing old and new style parts will cause permanent damage to the stator or voltage regulator.

4. See Figure 1. Place the smaller spacer washer (9) from the kit over the sprocket shaft.

CAUTION

Do not strike or drop the alternator rotor. The magnets could be loosened or damaged, which would result in rotor failure.

5. Install the new alternator rotor assembly (8) onto the sprocket.
6. Place the larger spacer (7) from the kit over the sprocket shaft. Place the original shim(s) (6) over the shaft.

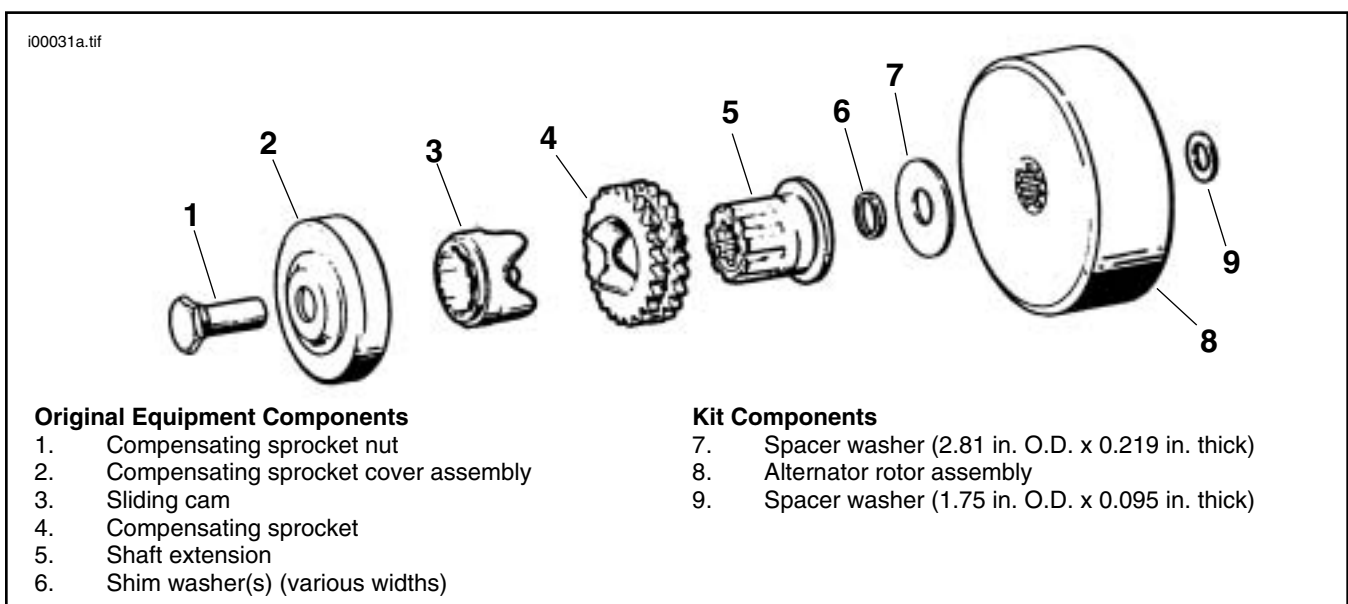

Figure 1: Alternator Rotor and Compensating Sprocket Assembly

7. Check the sprocket alignment.
 8. Apply Loctite® 262 (red) to the threads of the compensating sprocket nut (1).
 9. Install the nut and tighten to 80-100 ft-lbs (109-136 Nm).
 10. Measure the length of the original voltage regulator output lead, and cut the output lead on the replacement regulator to the same length.
- NOTE**
- The voltage regulator output lead should be connected to the same location as it was originally.*
- If the output lead will be connected to the battery positive terminal, install the larger ring terminal (3) from the kit.*
- If the output lead will be connected to the silver (LOAD SIDE) terminal of the main circuit breaker, install the smaller ring terminal (2).*
11. Strip 1/4 in. (6.4 mm) of insulation off the end of the output lead and install the appropriate ring terminal.
 12. Install the voltage regulator following Service Manual procedures.
 13. Depending on the connection location of the original voltage regulator output lead, connect the ring terminal of the replacement regulator to either the battery positive terminal or the silver (LOAD SIDE) terminal of the main circuit breaker.
 14. Secure the regulator wiring using the cable straps (4) from the kit.
 15. Refer to the Service Manual and follow the instructions given to re-attach the negative battery cable
 16. Test the vehicle to be sure the charging system is functioning properly.
 17. Remove the front crankcase stud and install the wireform plug retainer (9). Tighten the stud to 15-17 ft-lbs (20-23 Nm).
 18. Install the seat.

⚠ WARNING

After installing seat, pull upward on front of seat to be sure it is in locked position. While riding, a loose seat can shift causing loss of control, which could result in death or serious injury. (00070a)



Service Parts

Part No. 29982-81

Date 04/03

22-Amp Charging System

i00031a.eps

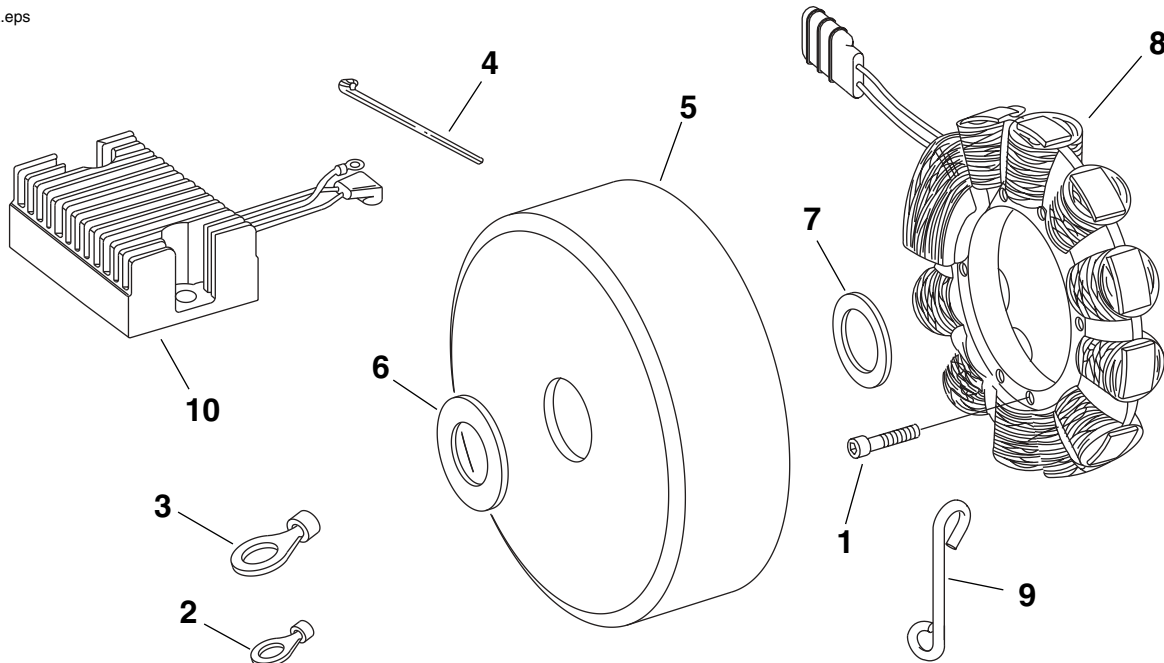

Item	Description (Quantity)	Part No.	Item	Description (Quantity)	Part No.
1	Screw, stator mounting (4)	2712	7	Spacer washer, 1.75 in. O.D., 0.095 in. thick	29961-85
2	Ring terminal #10 hole	9862	8	Stator assembly	29965-81B
3	Ring terminal 1/4 in. dia. ID	9863	9	Wireform plug retainer	45095-85
4	Cable strap (6)	10006	10	Voltage regulator assembly	74515-86
5	Alternator rotor assembly	29963-99			
6	Spacer washer, 2.81 in. O.D., 0.219 in. thick	29960-85			