

## Appliance Documentation

K(es) 3670 from Index 20 Premium

K(es) 4270 from Index 20 Premium

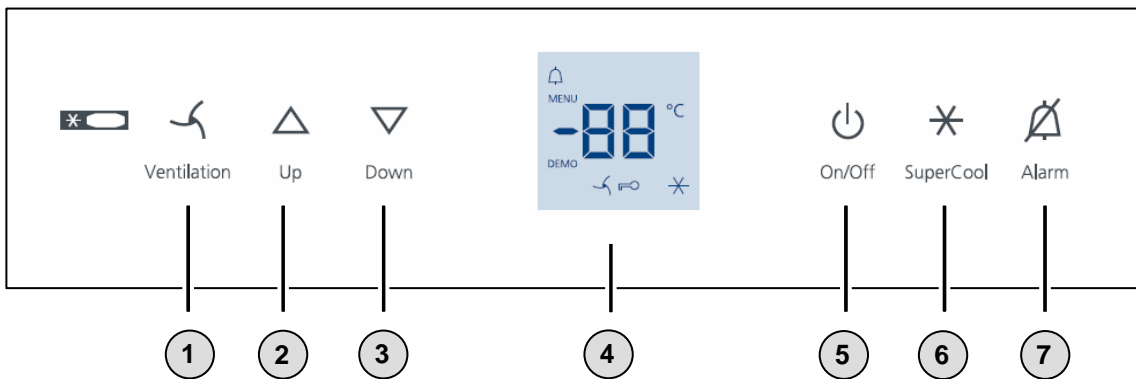
Free-standing refrigerator



## Contents

<b>1.0</b>	<b>Operating and control elements</b>	<b>3</b>
<b>2.0</b>	<b>Functions at a glance</b>	<b>4</b>
<b>3.0</b>	<b>Description of the appliance</b>	<b>5</b>
3.1	Sensor positions, schematic diagrams	5
<b>4.0</b>	<b>Main components and their functions</b>	<b>6</b>
4.1	Electrical components and functions	6
4.1.1	General	6
4.1.2	Refrigerator compartment	6
4.2	Refrigeration components and functions	7
4.2.1	General	7
4.2.2	Refrigerator compartment	7
<b>5.0</b>	<b>Assembly instructions / replacement of parts</b>	<b>8</b>
5.1	General	8
5.1.1	Electronic unit of control panel	8
5.1.2	Electronic power module	9
5.1.3	Top door hinge	11
5.1.4	Bottom door hinge	11
5.1.5	Door magnet	12
5.2	Refrigerator compartment	13
5.2.1	Air sensor	13
5.2.2	Evaporator sensor	14
5.2.3	Fan	15
5.2.4	Refrigerator compartment light	16
5.2.5	Pull-out rails vegetable drawer	18
<b>6.0</b>	<b>Technical data</b>	<b>19</b>
6.1	Refrigerator compartment	19
<b>7.0</b>	<b>Service menu</b>	<b>20</b>
7.1	Brief survey of service menu	20
7.2	Demo mode	21
7.3	Panel test	22
7.4	Sensor test (display of temperature) and door contact test	23
7.5	Service mode	24
<b>8.0</b>	<b>Error code, troubleshooting</b>	<b>24</b>
8.1	Table of error codes	24

## 1.0 Operating and control elements



**Symbol for .....**  
 symbol lit = function activated

	<b>SuperCool</b>
	<b>Ventilation</b>
	<b>Alarm</b>
	<b>Child lock</b>
	<b>Menu</b>
	<b>Demo mode</b>

### Refrigerator compartment

- 1 **Ventilation** Fan function
- 2 **Up** **Setting button** temperature **higher**
- 3 **Down** **Setting button** temperature **lower**
- 4 **Temperature display, function display**
- 5 **ON/OFF** ON/OFF button for refrigerator compartment
- 6 **SuperCool** SuperCool function
- 7 **Alarm** Alarm OFF button for audible alarm

## 2.0 Functions at a glance

**Control:** Electronic

**Temperature display:** Actual value

**Temperature range:** +2°C to +9°C

**Temperature alarm:** Not present

**Door alarm:** Audible

**Fan:** Present

**Defrosting:** Automatic

**Interior light:** Present

**Service menu:** Present

**Compressor:** Standard

**Solenoid valve  
refrigeration circuit:** Not present

### 3.0 Description of the appliance

The **K(es) 3670 / 4270** is a free-standing refrigerator with fan. The appliance is cooled by way of a freely suspended, rear wall evaporator. The appliance is regulated using an air sensor and an evaporator sensor. A fan can be optionally activated.

#### 3.1 Sensor positions, schematic diagrams

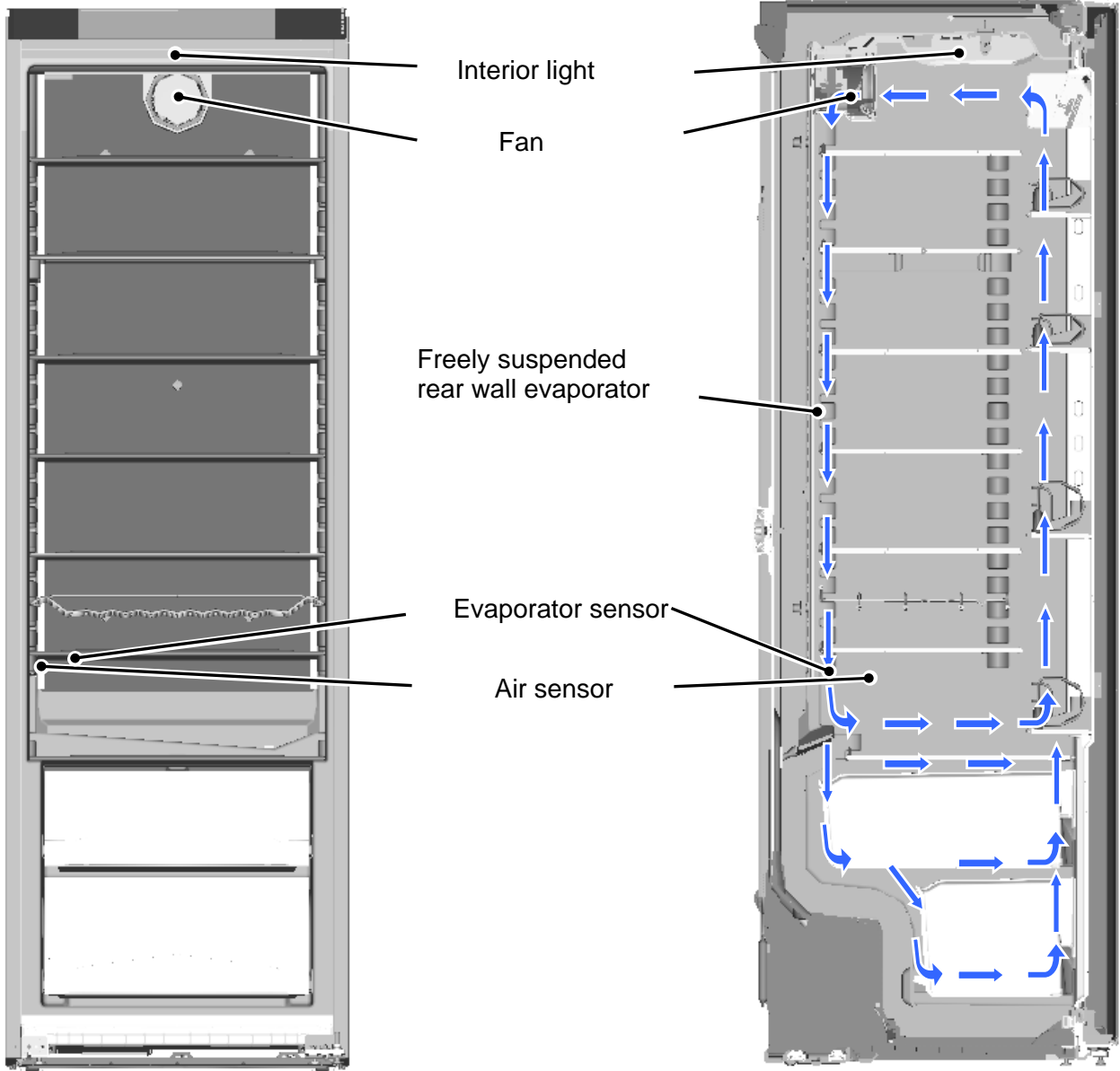


Fig. 3.1 / 1

Fig. 3.1 / 2

## 4.0 Main components and their functions

### 4.1 Electrical components and functions

#### 4.1.1 General

Electronic control system	
<b>Type:</b>	Series 6 electronic control system
<b>Components:</b>	Control panel and power PCB
Compressor	
<b>Type:</b>	Standard compressor.
<b>Function:</b>	<p><b>ON:</b> Evaporator sensor switch-on value. Note: On-delay time (8 mins.) must have elapsed.</p> <p><b>Off:</b> Air sensor switch-off value.</p>

#### 4.1.2 Refrigerator compartment

Electronic control system	
<b>Setting range:</b>	+2°C to +9°C
<b>Display range:</b>	+2°C to 50°C
Functions	
<b>Ventilation:</b> (see also under: Loads: - Fan)	<p><b><u>Ventilation activated:</u></b> Fan runs in parallel with compressor.</p> <p><b><u>Ventilation deactivated:</u></b> Fan is OFF. (Exception: SuperCool function activated)</p>
<b>SuperCool:</b>	<p><b><u>SuperCool activated:</u></b> Refrigerator compartment sets itself to +2°C for 6 hours. (Fan is ON)</p> <p><b><u>SuperCool deactivated:</u></b> The refrigerator compartment sets itself to the set value.</p>
<b>Defrosting:</b>	Automatic during compressor standstill phase.
<b>Door alarm:</b>	<p>When: If door is open, after 60 seconds.</p> <p>Audible: 3 beeps.</p>
Sensors	
<b>Refrigerator compartment air sensor:</b>	<p>Position: On the left, on a level with the lowest support rib.</p> <p>Function: - Switches the compressor OFF. - Generates the display value.</p>
<b>Evaporator sensor:</b>	<p>Position: On the back of the evaporator, on a level with the air sensor.</p> <p>Function: Switches compressor ON. - Ends the defrosting phase.</p>

**Switch**

**Door switch:** Position: In front panel  
 Type: Reed PCB  
 Contact type: make contact  
 Function: Activation via:  
 Magnet in the door, magnet is replaceable.  
**Switching signal when:**  
**door closed:** interior light OFF  
**door open:** interior light ON  
 fan OFF

**Loads**

**Fan:** Position: Beneath the ceiling of the appliance.  
 Function:

Ventilation	Compressor	door	Fan
ON	ON	CLOSED	ON
ON	ON	OPEN	OFF
ON	OFF	CLOSED	OFF
OFF	ON/OFF	CLOSED/OPEN	OFF

e.g. if the ventilation is ON and the compressor is ON and the door is CLOSED, then the fan is ON.)

During start-up the fan is activated only from an evaporator sensor temperature of +5°C and colder.

**Interior light of refrigerator compartment:** Position: Ceiling  
 Function: - Lights up as soon as door is opened.  
 - Is switched off after door has been open for 15 minutes.

**4.2 Refrigeration components and functions**

**4.2.1 General**

**Compressor**

**Compressor:** Standard compressor

**4.2.2 Refrigerator compartment**

**Evaporator**

**Type of design:** Rear wall evaporator

**Type of installation:** Suspended freely.

**Injection point:** Top centre

**Flow sequence:** Top to bottom

## 5.0 Assembly instructions / replacement of parts

### 5.1 General

#### 5.1.1 Electronic unit of control panel

Covers: Disengage covers at the marked points.



Fig. 5.1.1 / 1

Front panel: Unlock locating lugs at the left and right of the front casing.



Fig. 5.1.1 / 2

Bus connector: Disconnect and detach bus connector.

**Front panel can be replaced only as a unit, PCB is not separately available!**

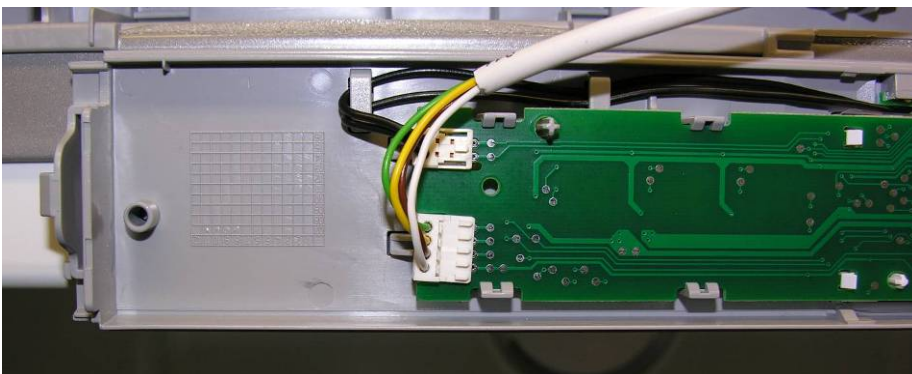


Fig. 5.1.1 / 3



### 5.1.2 Electronic power module

#### **Attention: Pull out the power plug!**

- Electronic power module cover:**
- Disengage marked retaining clips.
  - Swing out the cover at the bottom and lift for removal.

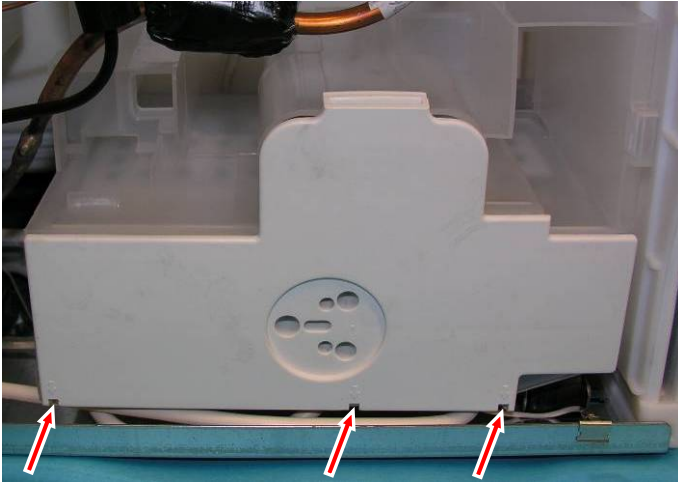


Fig. 5.1.2 / 1

- Cable clip:**
- Disengage the cable clip at the marked location.

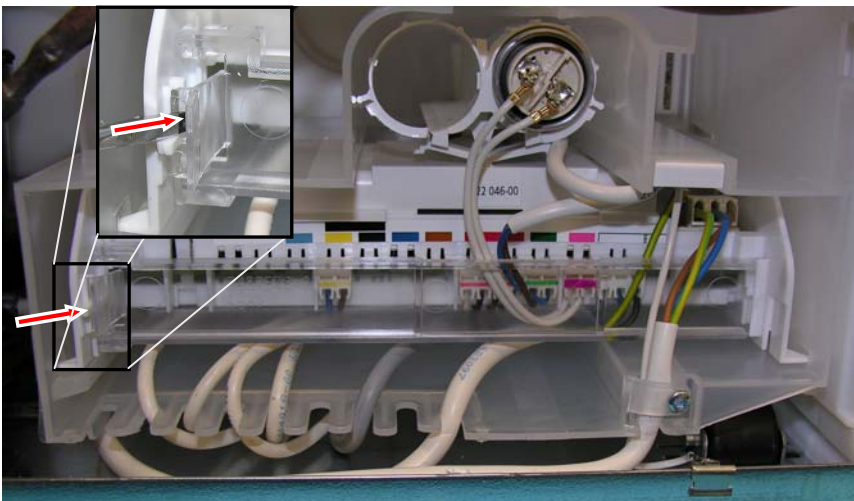


Fig. 5.1.2 / 2

- Detach front PCB edge connector
- Release strain relief of supply cable.
- Disengage plug-in module at the right and left clip at draw it forwards for removal.

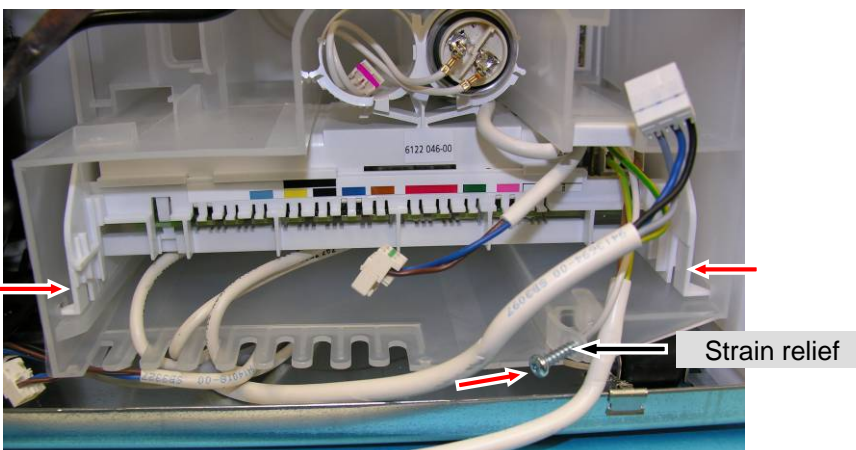


Fig. 5.1.2 / 3

**Plug-in module:** - Detach rear PCB edge connector.

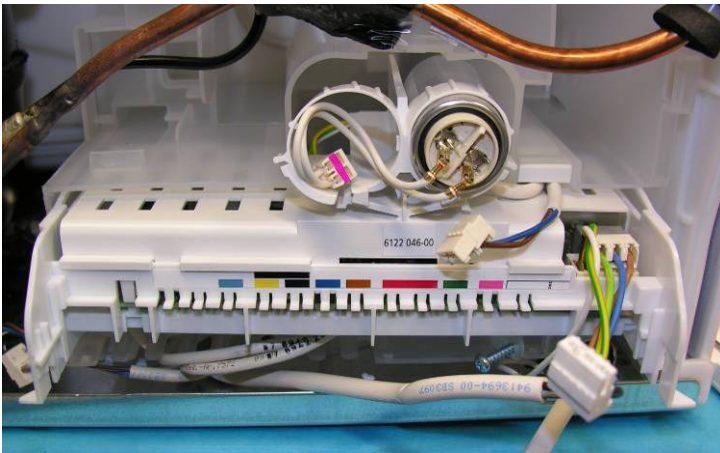


Fig. 5.1.2 / 4

**Electronic power module:** - Disengage locating hooks on the holder for capacitors.  
- Disengage electronic power module at the marked locations.

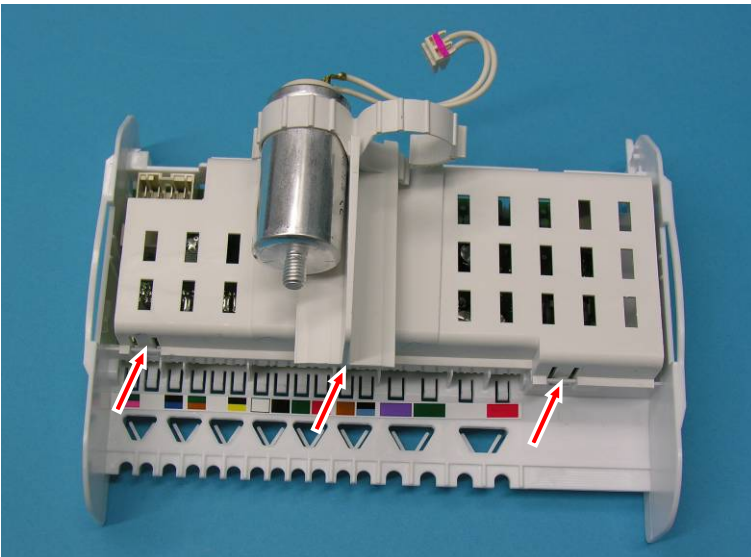


Fig. 5.1.2 / 5

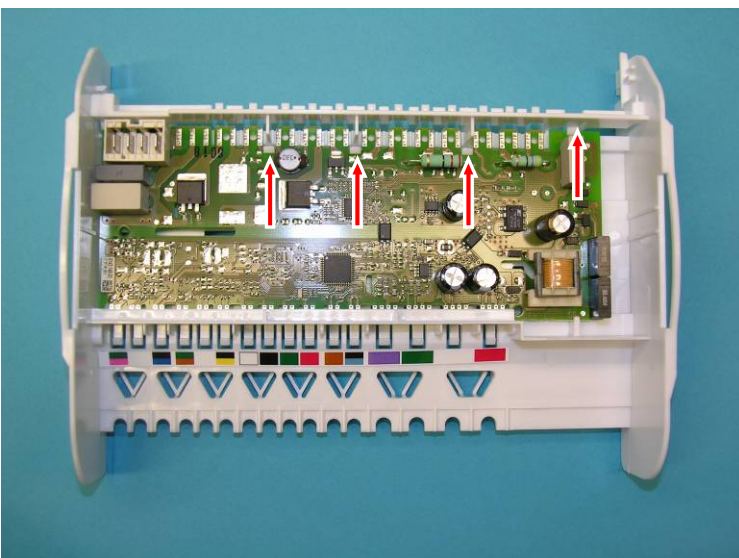


Fig. 5.1.2 / 6

### 5.1.3 Top door hinge

**Turn hinge cover:** Disengage cover in marked direction and lift for removal.

**Turn hinge:** Undo marked screws and remove turn hinge.



Fig. 5.1.3 / 1

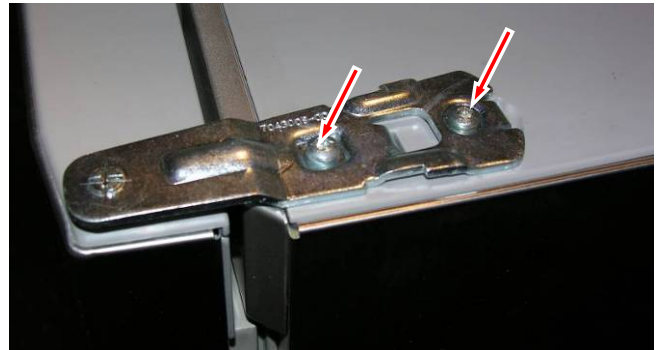


Fig. 5.1.3 / 2



Fig. 5.1.3 / 3



Fig. 5.1.3 / 4

### 5.1.4 Bottom door hinge

**Turn hinge cover:** Disengage the cover in the marked direction and remove it in a forward direction.

**Bearing pin:** Retract the adjustable foot and press the bearing pin downwards. Then swing the door out at the bottom and draw it out of the top bearing pin.

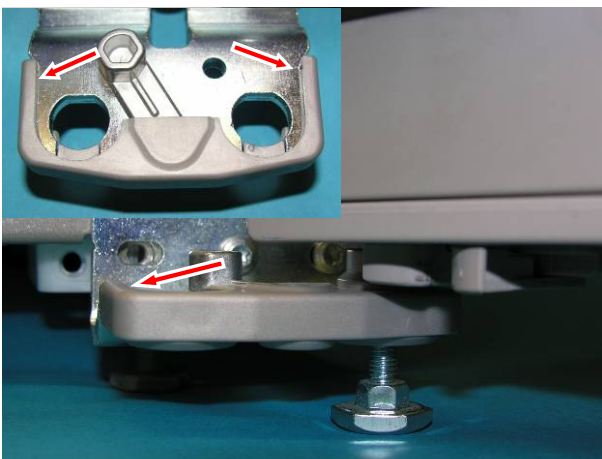


Fig. 5.1.4/ 1 Turn hinge cover

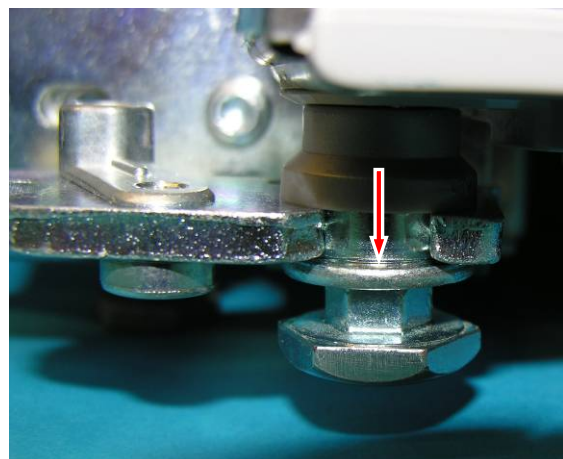


Fig. 5.1.4/ 2 Bearing pin

**Spring clip:** Depress the holder and remove the spring clip. Has to be transferred to the opposite side if the door hinges are changed over.

**Bottom bearing part:** Bottom bearing part has to be transferred if the door hinges are changed over.

**Slot:** Screw can be transferred to the slot to facilitate door adjustment.

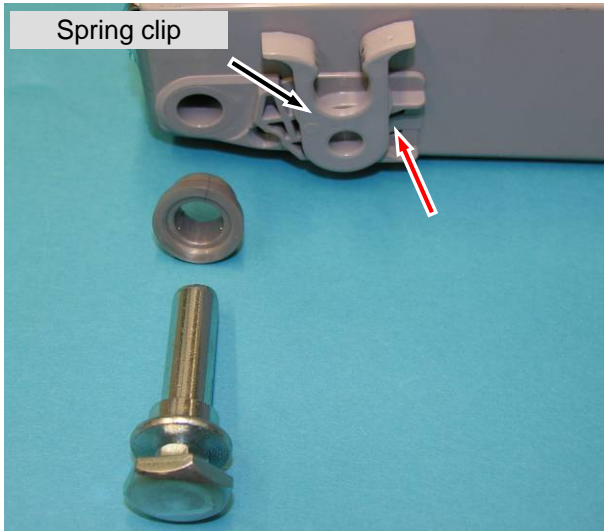


Abb. 5.1.4/ 3 Spring clip

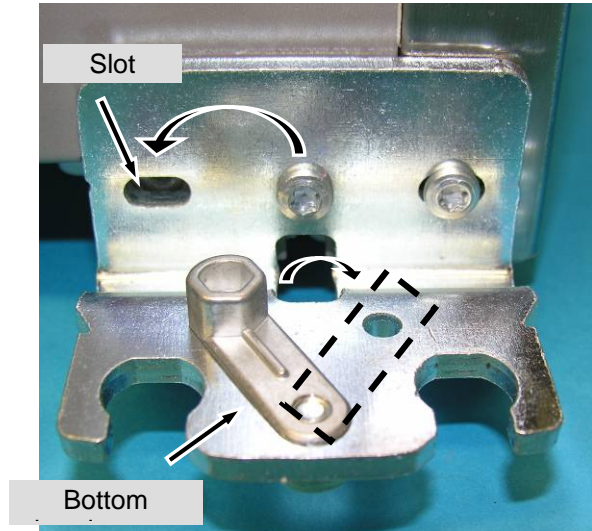


Fig. 5.1.4 / 4

### 5.1.5 Door magnet

**Magnet holder:** Depress marked locating lug and lever out the magnet holder in a forward direction.

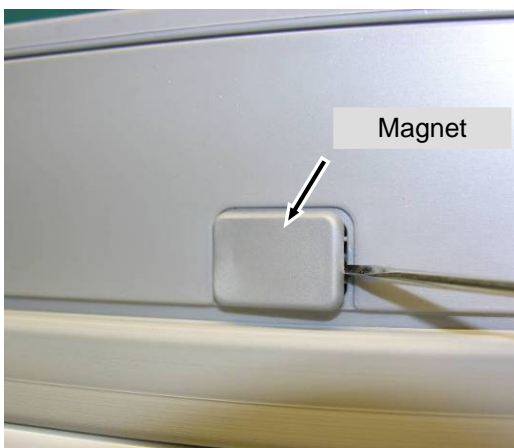


Fig. 5.1.5 / 1



Fig. 5.1.5 / 2

## 5.2 Refrigerator compartment

### 5.2.1 Air sensor

#### Refrigerator compartment air sensor:

- Remove glass shelves and glass shelf supports.
- Remove stopper.
- Undo screw.
- Unclip air sensor.
- Undo lower screws holding the evaporator.
- Press air sensor out, through the housing feed-through, behind the evaporator.
- Cut off air sensor cable and repair using repair kit (9590 088).

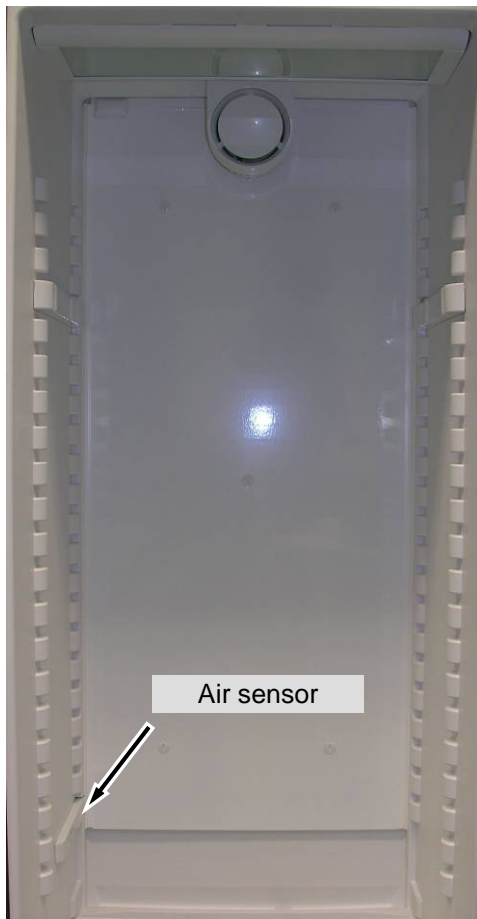


Fig. 5.2.1 / 1

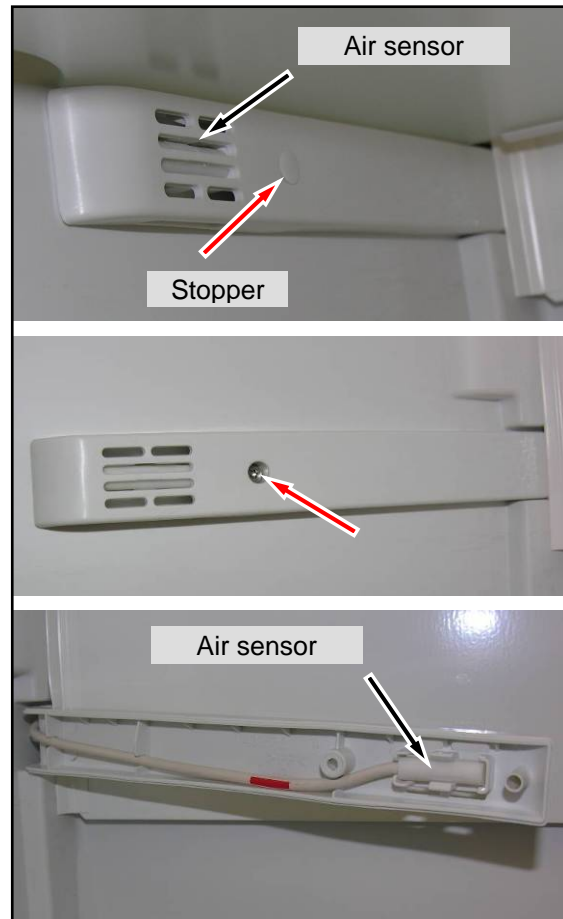


Fig. 5.2.1 / 2

## 5.2.2 Evaporator sensor

### Evaporator sensor:

- Remove glass shelves and glass shelf supports.
- Detach fan.
- Undo screws holding the evaporator.
- Press the evaporator down a little and fold to the left.
- Draw the evaporator sensor out of the sensor pocket and press it out through the housing feed-through.
- Cut off the evaporator sensor cable and repair using repair kit (9590 088).

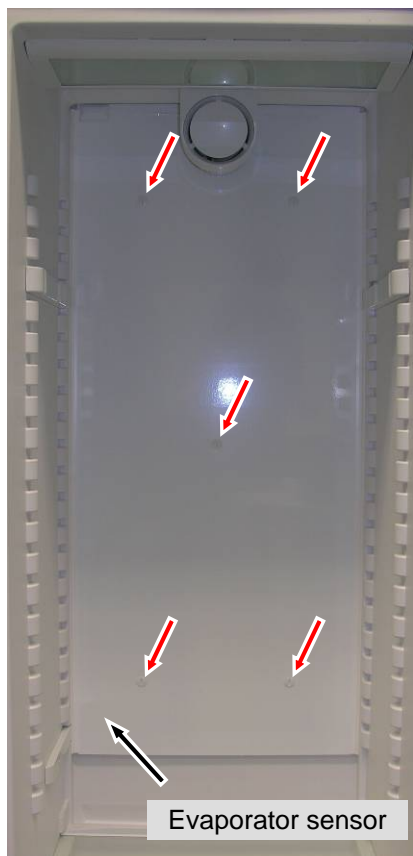


Fig. 5.2.2 / 1

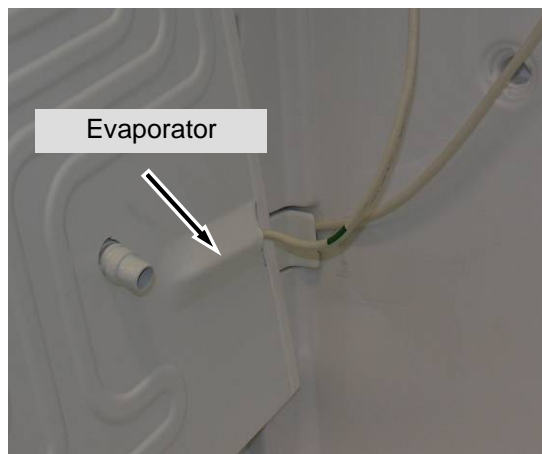


Fig. 5.2.2 / 2

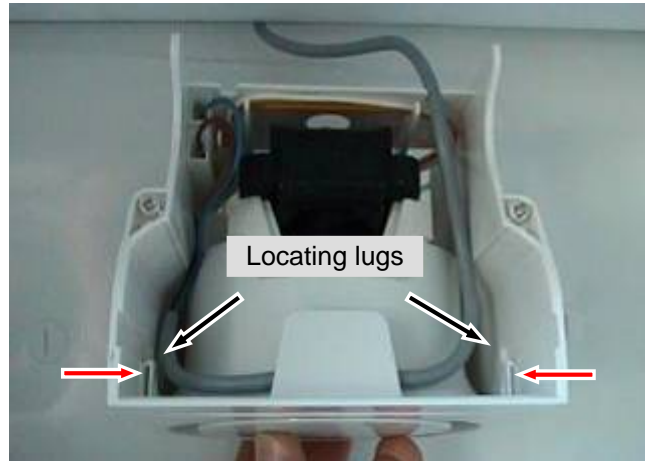
### 5.2.3 Fan

**Fan:**

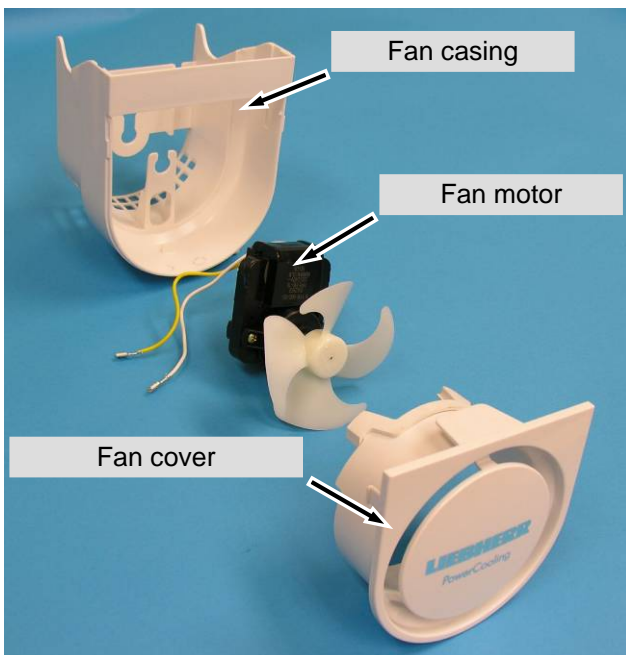
- Undo fastening screws of the fan (see **Fig. 5.2.3 / 1**).
- Pull off connecting cable (see **Fig. 5.2.3 / 2**).
- Disengage locating lugs of the fan cover (see **Fig. 5.2.3 / 2**) and remove fan cover in a forward direction.
- Lift fan motor out of the fan housing.



**Fig. 5.2.3 / 1** Fan



**Fig. 5.2.3 / 2** Fan cover



**Fig. 5.2.3 / 3** Fan components

### 5.2.4 Refrigerator compartment light

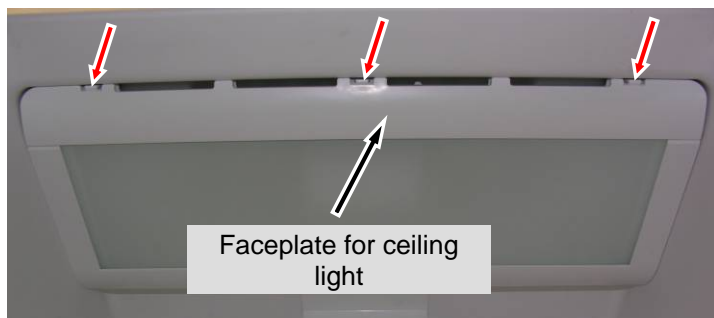


Fig. 5.2.4 / 1

Unlock and remove faceplate for ceiling light.



Fig. 5.2.4 / 2

Pull out glass plate in a forward direction.



Fig. 5.2.4 / 3

Undo fastening screws and fan fastener (see 5.2.3).



Fig. 5.2.4 / 4

Fold down the light housing.





Fig. 5.2.4 / 5

Disengage the reflector plate.  
**Info:** The reflector plate holds the lampholder cover.



Fig. 5.2.4 / 6

Remove lampholder cover



Fig. 5.2.4 / 7

### 5.2.5 Pull-out rails vegetable drawer

Pull-out rail: - Depress lock and press rail to the rear (Fig. 5.2.5 / 1).

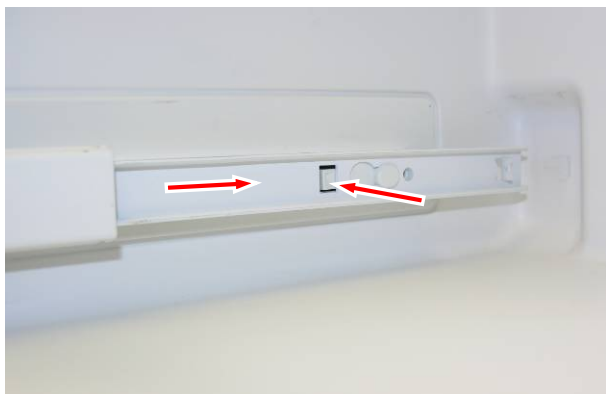


Fig. 5.2.5 / 1



Fig. 5.2.5 / 2

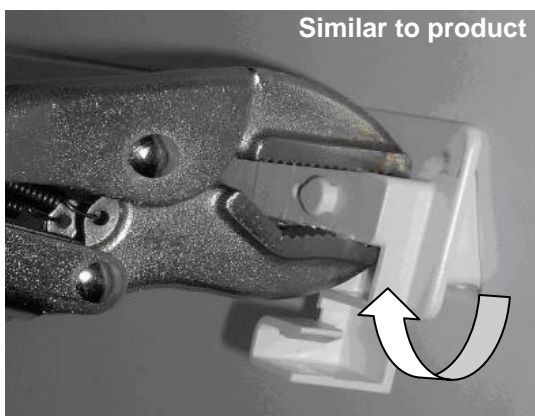
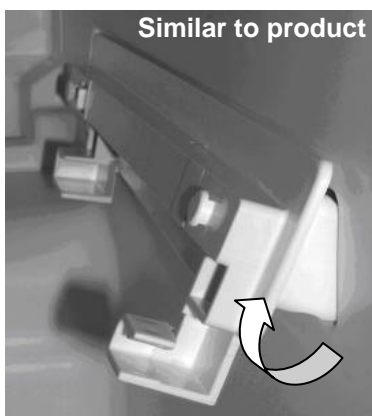


Fig. 5.2.5 / 3



## 6.0 Technical data

### 6.1 Refrigerator compartment

**Sensor values:** Air sensor and evaporator sensor

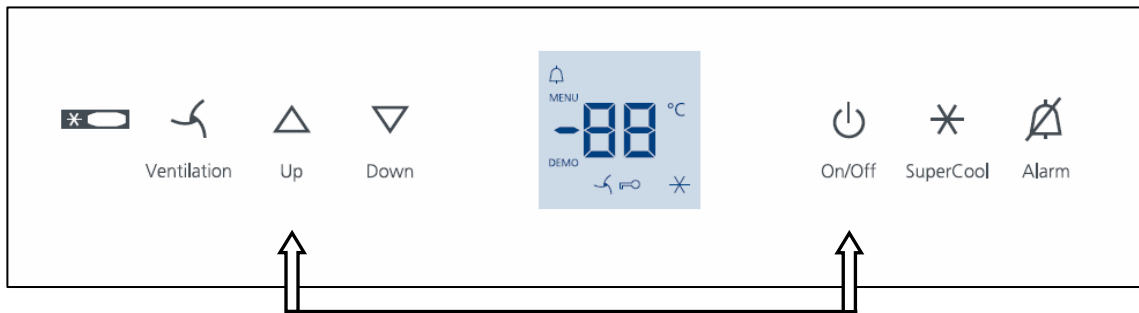
Temperature °C	Resistance value kOhm
+35	3.1
+30	3.8
+25	4.7
+20	5.9
+15	7.3
+10	9.3
+5	11.9
0	15.3
-5	19.8
-10	25.9
-15	34.1
-20	45.3
-25	60.8
-30	82.3
-35	112.8

**Interior light:**  
 Wattage: 2 x 25 watts  
 Voltage: 230 volts  
 Socket: E14

**Fan:**  
 Wattage: 7.5 watts  
 Voltage: 230 volts (50/60Hz)  
 Speed: 1650 rpm Direction of rotation: left (as viewed onto shaft)

## 7.0 Service menu

The service menu may be used by service technicians only.











**Activation of service menu:** Press "Up" + "ON/OFF" simultaneously for about 5 seconds

If the **service menu is activated**, then "MENU" flashes in the display.

### 7.1 Brief survey of service menu







Service menu	Menu	Operation	Submenu	Operation	Selection of functional part
Demo mode		1x SC	d0 ----- d1	1x SC	Demo mode ON ----- Demo mode OFF
Panel test	↑ P	1x SC	P1	1x SC	Press sensor buttons, door sensor
Sensor test	↑ E-	1x SC	E1	1x SC	Up-/Down button ↓/↑ E1 : Refrigerator compartment air sensor E2 : Refrigerator compartment evaporator sensor E8 : Refrigerator compartment door contact
Service mode	↓ E	1x SC	E1	1x SC	Up-/Down button ↓/↑ E0 : All OFF E1 : Compressor ON E5 : Light ON E7 : Fan

## 7.2 Demo mode

Step	Display	Operation	Display following operation	Testing option / Info
<b>Start service menu -- Demo mode ON --</b>				SC = SuperCool
1	Actual value	Press "Up" and "ON/OFF" simultaneously for 5 seconds	 flashes	Service menu active <b>Demo mode</b> selected
2	 flashes	Press "SC" once	 Static	<b>Demo mode ON</b> selected
3	 Static	Press "SC" once	Set value and " <b>Demo</b> "	<b>Demo mode ON</b>
<b>Start service menu -- Demo mode OFF--</b>				SC = SuperCool
1	Actual value and " <b>Demo</b> "	Press "Up" and "ON/OFF" simultaneously for 5 seconds	 flashes and " <b>Demo</b> "	Service menu active <b>Demo mode</b> selected
2	 flashes and " <b>Demo</b> "	Press "SC" once	 static and " <b>Demo</b> "	<b>Demo mode OFF</b> selected
3	 static and " <b>Demo</b> "	Press "SC" once	Actual value	<b>Demo mode OFF</b>
<p>The text "<b>Demo</b>" in the display informs about the <b>activated demo mode</b>.  <b>Demo mode</b> can be deactivated only via service menu, not by OFF/ON or disconnection from the supply.  <b>Operation switches to the mode wanted, demo mode or normal mode as soon as "SuperCool" has been actuated.</b></p>				

## 7.3 Panel test



Step	Display	Operation	Display following operation	Testing option / Info
<b>Service menu start</b>				SC = SuperCool
1	Actual value	Press "Up" and "ON/OFF" simultaneously for 5 seconds	 flashes	Service menu active
<b>Panel test</b> -- test of sensor buttons, display elements, door sensor and beep --				
2	 flashes	Press "Up" once	 flashes	<b>Panel test selected</b>
3	 flashes	Press "SC" once	 Static	<b>Panel test activated</b>
4	 Static	Press "SC" once	All symbols/segments	Display elements/ More symbols are displayed than the respective electronic control system uses!
5	All symbols/segments	Door closed/open and press all buttons one after the other  (confirmed by beep in each case)	- Beep for 2 seconds - Appliance switches OFF	After the last button has been pressed, a beep sounds for 2 seconds, provided the test was successful.
<b>End</b>	Panel test cannot be ended in step 2, for example, it has to be performed in full. Should a <b>button/sensor be defective, no beep</b> sounds for 2 seconds and the <b>appliance does not switch OFF</b> . The appliance then has to be unplugged and plugged back in again.			



7.4 Sensor test (display of temperature) and door contact test

Step	Display	Operation	Display following operation	Testing option / Info
<b>Service menu start</b>				SC = SuperCool
1	Actual value	Press "Up" and "ON/OFF" simultaneously for 5 seconds	d flashes	Service menu active
<b>Sensor test and door contact test</b> (sensor values without offset, appliance in control mode)				
2	d flashes	Press "Up" twice	E- flashes	Sensor test mode selected
3	E- flashes	Press "SC" once	E' Static	Sensor test mode activated
4	E' Static	Press "SC" once	'11 flashes alternately with sensor temperature	Refrigerator compartment air sensor
5	'11 flashes alternately with sensor temperature	Press "Up" once	'22 flashes alternately with sensor temperature	Refrigerator compartment evaporator sensor
6	'22 flashes alternately with sensor temperature	Press "Up" once	'R flashes alternately with oP or cL	Door contact (cL=door closed, oP=door open)
<b>End</b>	Press "ON/OFF" once: Return to level 2 E'. No further points selectable with this appliance. Press "ON/OFF" twice: Return to level 1 E-. Points: d, P, E-, L selectable Press "ON/OFF" three times: Return to normal/control mode			

## 7.5 Service mode



Step	Display	Operation	Display following operation	Testing option / Info	
<b>Service menu start</b>				SC = SuperCool	
1	Actual value	Press "Up" and "ON/OFF" simultaneously for 5 seconds	flashes	Service menu active	
<b>Service mode -- testing electric loads--</b>					<b>Power input</b>
2	flashes	Press "Up" 3 times	flashes	Service mode selected	
3	flashes	Press "SC" once	Static	Service mode activated	
7 → 4	Static	Press "SC" once	Static	All OFF	1.9 W
5	Static	Press "Up" once	Static	Compressor ON	--
6	Static	Press "Up" once	Static	Light ON	48 W
4 ← 7	Static	Press "Up" once	Static	Fan	7.5 W
<b>End</b>	Press "ON/OFF" once: Return to level 2 . No further points selectable with this appliance. Press "ON/OFF" twice: Return to normal/control mode.				

## 8.0 Error code, troubleshooting

### 8.1 Table of error codes

Error code	Defective component	Emergency mode
F1	Refrigerator compartment air sensor	Compressor ON 10 mins., OFF 22 mins.
F2	Refrigerator compartment evaporator sensor	Compressor ON 10 mins., OFF 22 mins.