

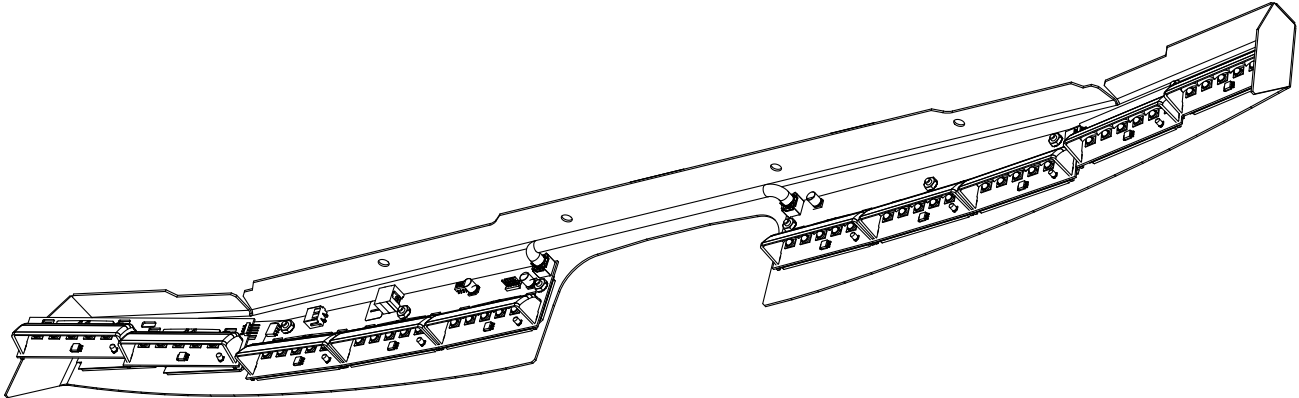

FEDERAL SIGNAL

Protecting people and our planet



SpectraLux 

Rear ILS Lightbar

***Installation, Maintenance,
and Service Manual***

Table of Contents

Safety Message to Installers and Service Personnel of Warning Light Equipment	5
Introduction	7
Unpacking the ILS	7
Wiring the Rear ILS in the Vehicle	7
SignalMaster Option.....	8
Lightbar Controls.....	8
Typical Installations with Common Control Systems	9
Selecting Configuration Options.....	9
Safety Message to Operators of Warning Light Equipment	11
Testing the Lightbar	12
Maintaining the Rear ILS	12
Cleaning the Shrouds.....	13
Cleaning the Reflectors.....	13
Servicing the Rear ILS	13
Replacing a PCB.....	13
Replacing a Reflector.....	15
Ordering Replacement Parts	16

List of Tables

Table 1 Rear ILS lightbar controls and their wires from the Serial Interface Module	9
Table 2 Rear ILS DIP switch settings.....	10
Table 3 Common replacement parts.....	16
Table 4 Vehicle-specific parts.....	16

List of Figures

Figure 1 DIP switches and lights on the control board of the Rear ILS	11
Figure 2 Removing a PCB.....	14
Figure 3 Removing a reflector	15
Figure 4 Typical connections with a SignalMaster controller (external control)	17
Figure 5 Typical connections with a SmartSiren Model SS2000SM.....	18
Figure 6 Typical connections with a serial-controlled lightbar and externally controlled SpectraLux Rear ILS....	19

ARJENT, LEGEND, RAYDIAN, SMARTSIREN, and SOLARIS are registered trademarks of Federal Signal Corporation
SIGNALMASTER, SpectraLux, and ROC are trademarks of Federal Signal Corporation

SpectraLux

Safety Message to Installers and Service Personnel of Warning Light Equipment

People's lives depend on your proper installation and servicing of Federal Signal products. It is important to read and follow all instructions shipped with this product. In addition, listed below are some other important safety instructions and precautions you should follow:

Before Installation or Service

Qualifications

- To properly install or service this equipment, you must have a good understanding of automotive mechanical and electrical procedures and systems along with proficiency in the installation and service of safety warning equipment. Always refer to the vehicle's service manuals when performing equipment installations on a vehicle.

Light Hazards

- To be an effective warning device, this product produces bright light that can be hazardous to your eyesight when viewed at a close range. Do not stare directly into this lighting product at a close range or permanent damage to your eyesight may occur.
- Do not install the light system in an area that would block, impair, or blind the driver's vision. Ensure that the light system is mounted in a position that is outside of the driver's field of vision, so the driver can safely operate the vehicle.
- Federal Signal power supplies and light heads are designed to work together as a system. Combining light heads and a power supply from different manufacturers may reduce the warning effectiveness of the lighting system and may damage the components. You should verify or test your combination to ensure the system works together and meets federal, state, and local standards or guidelines.

Electrical Hazards

- Strobe systems present a shock hazard because they use high voltage to operate. Do not handle strobe cables, the power supply, or bulbs or remove the lens while the equipment is connected. Strobe systems can also hold their charge even after they have been turned off. After disconnecting power to the unit, wait five minutes before handling any parts of the strobe system.
- A light system is a high current system. In order for the system to function properly, a separate negative (-) connection and positive (+) connection must be made. All negative connections should be connected to the negative battery terminal and a suitable fuse should be installed on the positive battery terminal connection as close to the battery as possible. Ensure that all wires and fuses are rated correctly to handle the device and system amperage requirements.
- Never attempt to install aftermarket equipment that connects to the vehicle wiring without reviewing a vehicle wiring diagram available from the vehicle manufacturer. Ensure that your installation will not affect vehicle operation or mandated safety functions or circuits. Always check the vehicle for proper operation after installation.
- The lighting system components, especially light bulbs, strobe tubes, LEDs, and the outer housing, get hot during operation. Be sure to disconnect power to the system and allow the system to cool down before handling any components of the system.
- Do not mount a radio antenna within 18 inches (45.7 cm) of the lighting system. Placing the antenna too close to the lighting system could cause the lighting system to malfunction or be damaged by strong radio fields. Mounting the antenna too close to the lighting system may also cause the radio noise

emitted from the lighting system to interfere with the reception of the radio transmitter and reduce radio reception.

- Do not attempt to wash any unsealed electrical device while it is connected to its power source.

During Installation and Service

- DO NOT get metal shavings inside the product. Metal shavings in the product can cause the system to fail. If drilling must be done near the unit, place an ESD-approved cover over the unit. Inspect the unit after mounting to be sure there are no shavings present in or near the unit.
- DO NOT connect this system to the vehicle battery until ALL other electrical connections are made, mounting of all components is complete, and you have verified that no shorts exist. If the wiring is shorted to the vehicle body or frame, high current conductors can cause hazardous sparks resulting in electrical fires or flying molten metal.
- DO NOT install equipment or route wiring (or the plug in cord) in the deployment path of an airbag.
- Before mounting any components, check the manual to be sure that the component you are installing is suitable for use in that area of the vehicle. Many components are not suitable for use in the engine compartment or other extreme environmental exposure areas.
- When drilling into a vehicle structure, be sure that both sides of the surface are clear of anything that could be damaged. Remove all burrs from drilled holes. To prevent electrical shorts, grommet all drilled holes through which wiring passes. Also, ensure that the mounting screws do not cause electrical or mechanical damage to the vehicle.
- Refer to the manual packed with the lighting system for proper electrical connections, additional precautions, and information.
- Because vehicle roof construction and driving conditions vary, do not drive a vehicle with a magnetically mounted warning light installed. The light could fly off the vehicle causing injury or damage. Repair of damage incurred because of ignoring this warning shall be the sole responsibility of the user.
- To avoid denting the roof of the vehicle, place the lightbar mounting feet as close to the outer edge of the roof as possible.
- Locate the light system controls so the VEHICLE and CONTROLS can be operated safely under all driving conditions.

After Installation or Service

- After installation, test the light system to ensure that it is operating properly.
- Test all vehicle functions, including horn operation, vehicle safety functions, and vehicle light systems, to ensure proper operation. Ensure that the installation has not affected the vehicle operation or changed any vehicle safety function or circuit.
- Scratched or dull reflectors, mirrors, or lenses will reduce the effectiveness of the lighting system. Avoid heavy pressure and use of caustic or petroleum based products when cleaning the lighting system. Replace any optical components that may have been scratched or crazed during system installation.

- Do not attempt to activate or de-activate the light system control while driving in a hazardous situation.
- You should frequently inspect the light system to ensure that it is operating properly and that it is securely attached to the vehicle.
- After installation and testing are complete, provide a copy of these instructions to instructional staff and all operating personnel.
- File these instructions in a safe place and refer to them when maintaining and/or re-installing the product.

Failure to follow all safety precautions and instructions may result in property damage, serious injury, or death.

RETAIN AND REFER TO THIS MESSAGE

Introduction

The Rear SpectraLux ILS is a single-level LED lightbar that mounts in the rear window of the vehicle. It uses ROC (Reliable On Board Circuitry) technology, and SOLARIS® S2 reflectors. The lightbar operates at a nominal input of 13.6 Vdc (11 Vdc minimum). The functions of the ILS are controlled through the CAT5 serial communication cable. The cable connects to either a compatible Federal Signal Serial control head or a Federal Signal Serial Interface Module (document P/N 8583446). An internal PCB assembly within the lightbar decodes the control data and performs the requested function. With the Serial Interface Module, the lightbar can be activated by Federal Signal lightbar controllers, SignalMaster™ controllers, and/or individual low-current switches.

The backbone is a powder-coated aluminum shroud. The lightbar has 15 ft power and ground cables and a 25 ft serial cable. Mounting hardware is a configured option. Refer to mounting instructions supplied with mounting hardware. The lightbar has an operating temperature range of –30 °C to +65 °C..

Unpacking the ILS

After unpacking the ILS light assembly, inspect it for damage that may have occurred in transit. If it has been damaged, do not install it. File a claim immediately with the carrier, stating the extent of damage. Carefully check all envelopes, shipping labels, and tags before removing or destroying them. Ensure that the parts listed in kit contents list are included in the package. If you are missing any parts, contact Customer Support at 1-800-264-3578, 7 a.m. to 5 p.m., Monday through Friday (CT).

Wiring the Rear ILS in the Vehicle

Before proceeding, ensure that the lightbar has been installed inside the vehicle in accordance with the instructions included with the mounting kit.

NOTE: The DIP switch on the control PCB in the lightbar provides two selectable options. To change DIP switch settings, see “Selecting Configuration Options” on page 9.

The lightbar is completely wired at the factory and does not require any additional internal wiring. Two 16 AWG power conductors (red and black) and the CAT5 communication cable exit the lightbar. The conductors necessary to control the lightbar are contained in the CAT5 cable, which connects to a compatible Federal Signal control head or Serial Interface Module.

⚠ WARNING

RADIO ANTENNA LOCATION—Do not mount a radio antenna within 18 inches (45.7 cm) of the lighting system. Placing the antenna too close to the lighting system could cause the lighting system to malfunction or be damaged by strong radio fields. Mounting the antenna too close to the lighting system may also cause the radio noise emitted from the lighting system to interfere with the reception of the radio transmitter and reduce radio reception.

⚠ WARNING

LOCATING OPERATOR CONTROLS—The light system controls must be located so that the **VEHICLE** and **CONTROLS** can be operated safely under all driving conditions. Failure to observe this warning could result in driver distraction or driver error while operating the vehicle.

NOTICE

REVERSE POLARITY MISWIRING—Reverse polarity may damage the lightbar and prevent operation. To avoid damage to the lightbar, ensure that the battery voltage is the same as the voltage of the lightbar and that the correct polarity is observed. The lightbar must be fused at the source.

To wire the lightbar in the vehicle:

1. Ensure that the lines are adequately fused (see Figures 4 through 6 starting on page 17). From the lightbar, route the CAT5 control cable into the vehicle's cab or trunk near the planned location of a control head that is compatible with the lightbar or Serial Interface Module.

NOTE: An input cable (24-pin harness) is provided with the Serial Interface Module. For connections, see Table 1 on page 9 and Figures 4 through 6 starting on page 17.

2. Connect the 16 AWG black lead to the vehicle battery's ground (–NEG) terminal.
3. Connect the 16 AWG red lead through the supplied 15A fuse at the source to the positive (+BAT) terminal.

SignalMaster Option

The SignalMaster function is configured at the factory and does not require any additional wiring inside the lightbar. All conductors necessary for control of the SignalMaster are through the compatible serial communication control head or the Serial Interface Module. For wiring and operation, refer to the instructions included with the control head or document P/N 2562248 included with the Serial Interface Module.

Lightbar Controls

Both the Federal Signal Serial Control Head and the Serial Interface Module provide the controls in Table 1 to the lightbar. The table shows the corresponding control wires from the Serial Interface Module and their colors. The wire's first color is the predominant color and additional colors are stripes.

For programming options, see the instructions included with the Interface Module or the Federal Signal serial control head.

Table 1 Rear ILS lightbar controls and their wires from the Serial Interface Module

Lightbar Control*	Wire Color	Function Description
Mode 1	Blue	Lowest priority
Mode 2	Blue/White	Overrides Mode 1
Mode 3	Black/Red	Overrides Modes 1 and 2
Steady Burn	Red/White	N/A
Front Cutoff	Green/White	N/A
Front Enable		N/A
Rear Cutoff	Orange/Black	Turns OFF power to the Rear ILS
Rear Enable		Turns ON power to the Rear ILS
Intersection	Blue/Black	N/A
Flash Takedown	Red/Black	N/A
Left Alley	Green/Black	N/A
Right Alley	Orange/Red	N/A
Takedown	White/Black	N/A
Intersection	Blue/Black	N/A
Low Power	White/Black/Red	Dims the lights approximately 50 percent to prevent blinding approaching drivers. Low Power is only available in Modes 1 and 2 and is disabled when switched to another flash pattern, including Mode 3 and Intersection.
Test Pattern (SW-2 Switch 3 in the Serial Interface Module is in the UP position.)	Black/White/Red	Cycles through each available color

*See document P/N 2562248 for instructions on setting these options in the Serial Interface Module.

Typical Installations with Common Control Systems

For typical installations with common control systems, see Figures 4 through 6 starting on page 17.

Selecting Configuration Options

The Rear ILS has three configuration options that are selectable with DIP switches on the lightbar control board. Table 2 on page 10 describes the options.

Table 2 Rear ILS DIP switch settings

DIP Switch Position	Description
1	Sets the directional arrow pattern for internal SignalMaster control for the eight (default) or six-head pattern. For the six-head pattern, move DIP Switch 1 to ON (Figure 1 on page 11).
2	Not used
3	<p>Switch 3 has three functions:</p> <ul style="list-style-type: none"> • Activating a lower or upper rear-mounted ILS • Performing an LED scan to ensure that an LED board flashes the correct colors after it is installed. • Changing the Device ID to enable the SpectraLux ILS to operate independently of the lightbar (available with the Convergence Configuration Software). <p>Choosing to Activate an Upper or Lower Rear ILS To activate a upper rear-mounted ILS, set Switch 3 ON. To activate a lower rear-mounted ILS, set Switch 3 OFF.</p> <p>Performing an LED Scan When an LED board is changed, an LED scan must be done to enable the LED board to flash the correct colors. To perform the scan:</p> <ol style="list-style-type: none"> 1. Disconnect the red power (BAT+) wire to the SpectraLux ILS and maintain power to the control head/interface box. 2. Change the position of DIP Switch 3 and turn power ON to the SpectraLux ILS. The SpectraLux ILS emits a short flash to indicate the LED scan is done. 3. To return DIP Switch 3 to its original function, repeat the scan. <p>Changing the Device ID The default setting for the SpectraLux ILS is to respond to lightbar commands. For example, if the system includes a lightbar and a SpectraLux ILS, both devices perform the same functions. The Convergence Configuration programming software enables you to program the control head to send a set of commands dedicated only to the SpectraLux ILS, making its operation independent of the lightbar. To reset the control head to the default setting, perform an LED scan as described above.</p>
4	Sets the ability to power the network cable for other devices. The default is OFF. Switch 4 should only be set if the main power cables are turned on through an ignition-activated relay. If powering other devices, such as the Six-Button Serial Controller, set DIP Switch 4 to ON. For more information, see the instructions included with the network-powered device.

Figure 1 DIP switches and lights on the control board of the Rear ILS

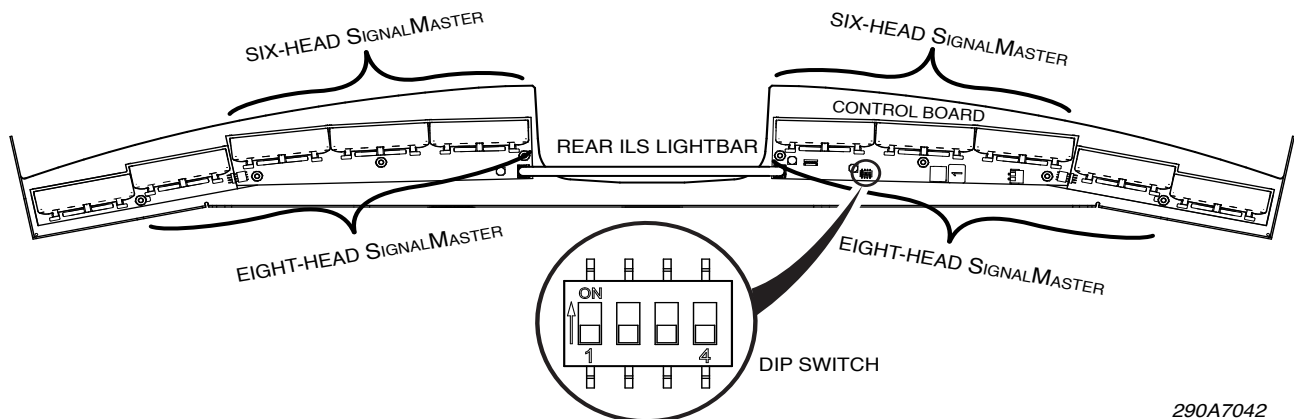

290A7042

Safety Message to Operators of Warning Light Equipment

People's lives depend on your safe use of our products. Listed below are some important safety instructions and precautions you should follow:

- Do not attempt to activate or de-activate the light system control while driving in a hazardous situation.
- Although your warning system is operating properly, it may not be completely effective. People may not see or heed your warning signal. You must recognize this fact and continue driving cautiously.
- Also, situations may occur which obstruct your warning signal when natural and man-made objects are between your vehicle and others, such as raising your hood or trunk lid. If these situations occur, be especially careful.
- The effectiveness of an interior mounted warning light depends on the clarity, the tinting, and the angle of the glass it is being placed behind. Tinting, dirt defects, and steeply angled glass reduce the light output of the warning light. This may reduce the effectiveness of the light as a warning signal. If your vehicle has dirty, tinted, or steeply angled glass, use extra caution when driving your vehicle or blocking the right of way with your vehicle.
- All effective sirens and horns produce loud sounds that may cause, in certain situations, permanent hearing loss. You and your passengers should consider taking appropriate safety precautions, such as wearing hearing protection.
- In order to be an effective warning device, this product produces bright light that can be hazardous to your eyesight when viewed at a close range. Do not stare directly into this lighting product at a close range or permanent damage to your eyesight may occur.
- It is important that you fully understand how to safely operate this warning system before use.
- You should only operate your vehicle and its light/sound system in accordance with your department's Standard Operating Procedures.
- If a selected function does not perform properly or if any of the lamps remain illuminated when the control is off, disconnect the power connector from the control unit and contact the nearest service center.
- At the start of your shift, you should ensure that the entire warning light system and the siren system is securely attached and operating properly.

- Suction cup mounting is for temporary applications only. The unit should be removed from the window and stored securely when not in use. Temperature changes and sunlight can cause suction cups to lose holding power. Periodically check the unit to be sure the suction cups have a firm grip on the mounting surface. An improperly secured light could fall off of the vehicle causing injury and damage.
- The holding power of magnetic mounting systems is dependent upon surface finish, surface flatness, and thickness of the steel mounting surface. Therefore, to promote proper magnetic mounting:
 - ✓ Mounting surface and magnets must be kept clean, dry, and free of foreign particles that prevent good surface contact.
 - ✓ Ensure that mounting surface is flat.
 - ✓ A magnet mounting system should not be used on vehicles with vinyl tops.
 - ✓ To prevent sliding of light assembly on mounting surface, quick acceleration and hard stops should be avoided.

Failure to follow these precautions may result in property damage, serious injury, or death.

RETAIN AND REFER TO THIS MESSAGE.

Testing the Lightbar

⚠ WARNING

LIGHT HAZARD—This product contains high output LED devices. To prevent permanent eye damage, do not stare into the light beam at close range.

To check the lightbar controls (see Table 1 on page 9 and the wiring diagrams on pages 18 and 19):

1. Connect the 16 AWG black lead from the lightbar to the ground (–NEG) terminal of the vehicle battery and the 16 AWG red lead to the positive terminal.
2. Connect the black and black/white wires from the Serial Interface Module to the ground (–NEG) terminal of the vehicle battery
3. Apply 12 Vdc to a control wire and to the ignition wire from the Serial Interface Module.

After the installation, check the entire system to be sure the lights are flashing properly and all light system functions are operating properly.

Maintaining the Rear ILS

Establishing a regular maintenance schedule for the ILS lightbar extends its life and ensures safety. Periodically check that the lightbar operates properly and that all mounting hardware is securely fastened to the vehicle. Also, inspect the reflectors for cracks, crazing (hairline cracks), discoloration, and other defects.

⚠ WARNING

PERIODICALLY CHECK GLASS—The effectiveness of the Rear ILS depends on the clarity of the glass it is being placed behind. Dirt and defects in the glass reduces the light output. The reliability of light for emergency signaling purposes may be reduced if the glass is dirty, cracked, or not clear. Be sure to periodically check the glass for cleanliness to ensure maximum light output of the Rear ILS lightbar.

Cleaning the Shrouds

To clean the shrouds:

1. To remove the lightbar from the vehicle, refer to the vehicle-specific installation instructions that come with the ILS lightbar.
2. Use a soft tissue to clean the shroud. If needed, you can use a solution of mild soap and water, but take care not to get water on the PCBs.
3. When finished, make sure the lightbar is completely dry before reinstalling it according to the vehicle-specific installation instructions.

Cleaning the Reflectors

⚠ WARNING

CRAZING/CLEANING SOLUTIONS—The use of cleaning solutions, such as strong detergents, solvents, and petroleum products, can cause crazing (cracking) of the reflectors. Failure to follow this warning can damage the reflectors and reduce the effectiveness of the light output, which may result in bodily injury or death to you or others.

To clean the reflectors:

1. To remove the lightbar from the vehicle, refer to the vehicle-specific installation instructions included with the Rear ILS.
2. Use a soft tissue to clean the reflectors. If needed, you can use a solution of mild soap and water, but take care to avoid getting the PCBs wet. Avoid heavy pressure and the use of caustic, abrasive, or petroleum-based cleaners, which will scratch or dull the reflectors.
3. When finished, make sure the lightbar is completely dry before reinstalling it according to the vehicle-specific instructions.

Servicing the Rear ILS

This section has instructions for replacing the lightbar's PCBs and reflectors. For additional service and support, call the Federal Signal Service Department at 800-433-9132, 7 a.m. to 5 p.m., Monday through Friday (Central Time). For a list of common replacement parts, see "Ordering Replacement Parts" on page 17.

Replacing a PCB

To replace a PCB:

1. To remove the lightbar from the vehicle, refer to the vehicle-specific installation instructions that come with the Rear ILS.

NOTE: To remove an inner PCB you must first remove the outer PCB next to it.

2. See Figure 2 on page 15. Remove the #10-32 nuts that hold down the PCB.

NOTICE

PCB CONNECTOR DAMAGE—To avoid damaging the connectors, slide the outer PCB straight out before lifting it.

3. Remove the outer PCB by sliding it straight outward and then lifting it by its outside edge. To remove an inner PCB, make sure all the nuts have been removed. Disconnect the cable and lift out the PCB.

NOTE: To remove a reflector, see “Replacing a Reflector” on page 16.

4. To install an inner PCB, align the holes in the PCB with the three inner studs on the shroud and place the PCB on the insulator.
5. Mate the pins of the outer PCB to the inner PCB on an angle.
6. Slide the outer PCB in while lowering its outer edge until the stud is centered in the slot on the PCB. Rest the PCB on the insulator.
7. Tighten the #10-32 nuts to 36 in-lb (3 ft-lb).

Figure 2 Removing a PCB

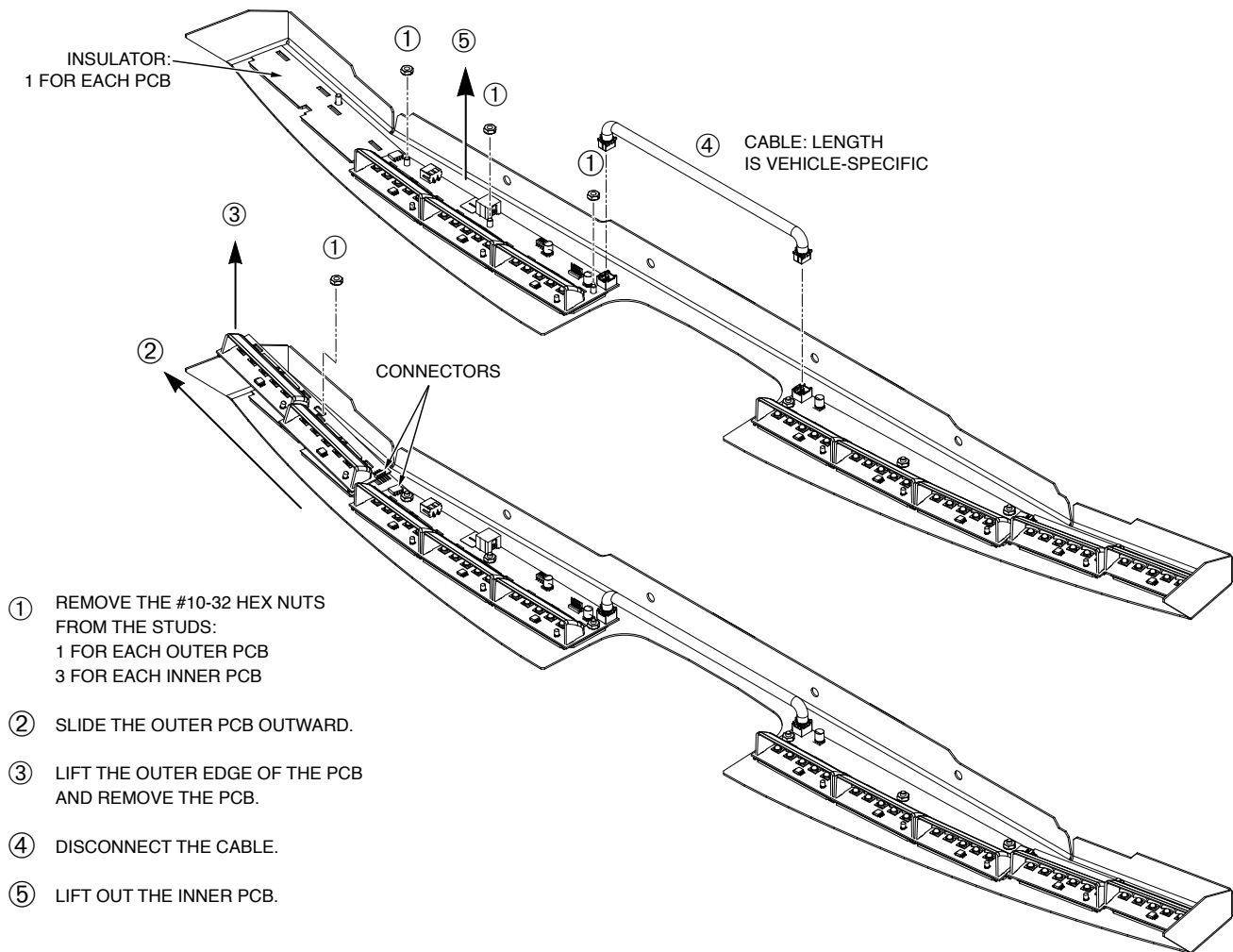

290A7043

Replacing a Reflector

⚠ WARNING

CRAZING/CHEMICALS—Crazed, cracked, or faded reflectors reduce the light output and the effectiveness of the lighting system. Reflectors showing this type of aging must be replaced. Failure to follow this warning may result in bodily injury or death to you or others.

To replace a reflector:

1. Refer to the vehicle-specific installation instructions included with the Rear ILS.
2. To remove the PCB that holds the reflector, see “Replacing a PCB” on page 14.
3. Use a small Phillips screwdriver to press and release the reflector’s two round tabs from beneath the PCB. Slide the reflector toward the rear of the PCB (Figure 3).
4. Lift the rear of the reflector away from the PCB and remove it.

Figure 3 Removing a reflector

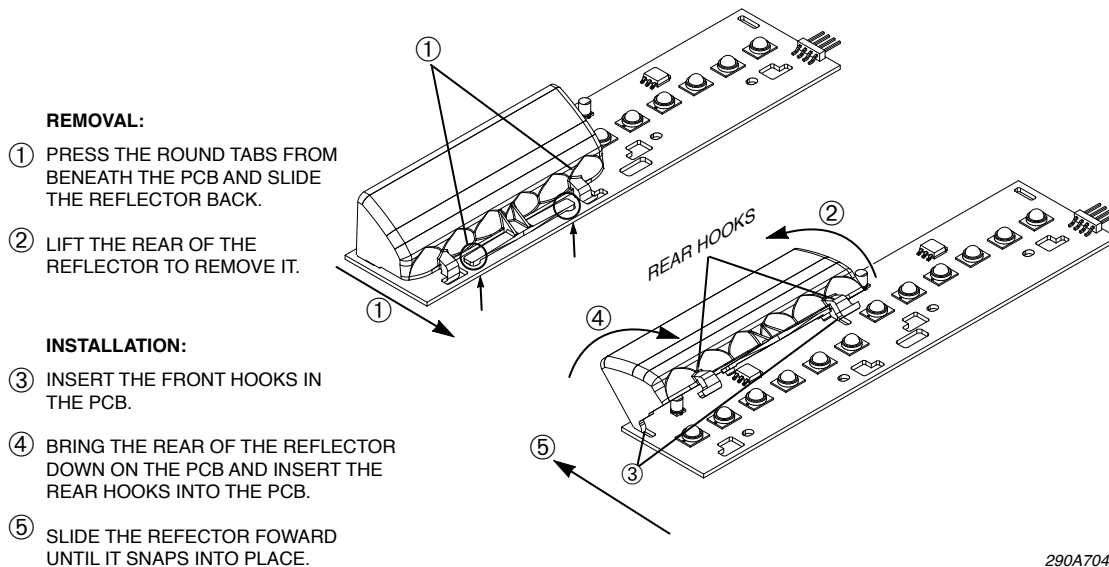

5. To install the new reflector, insert its front hooks into their slots on the PCB.
6. Bring the rear of the reflector down to insert its rear hooks through the PCB.
7. When the reflector rests on the PCB, make sure the rear hooks are fully inserted and slide the reflector forward until its tabs snap into place.
8. Install the PCBs as described in steps 4 through 7 in “Replacing a PCB” on page 14.

Ordering Replacement Parts

This section contains a list of common and vehicle-specific replacement parts. To order parts, call the Federal Signal Service Department at 800-433-9132, 7 a.m. to 5 p.m., Monday through Friday (CT) or contact your nearest distributor.

Table 3 Common replacement parts

Description	Part Number
PCB Assembly, Driver Side (Configured)	Contact Federal Signal
PCB Assembly, Driver Rear Inner (Configured)	Contact Federal Signal
PCB Assembly, Passenger Side (Configured)	Contact Federal Signal
PCB Assembly, Passenger Rear Inner (Configured)	Contact Federal Signal
Insulator, Rear	8624178
Aluminum Spacer, Rear	8624179
Nut, Hex #10-32	7058A004
Reflector, Standard	8651110
Sealing Strip	205003
Cable Assembly, Power, 15 ft	1461816
Cable, Network, 25 ft	1751357-02
Fuse, In-Line, 15 A	8620006-01
Fuse Holder	143A120

Table 4 Vehicle-specific parts

Description	Part Number
Wire Assembly, PCB to PCB (Vehicle-Specific Length)	17500009-**
Shroud and Mounting Hardware (Vehicle-Specific)	Refer to the vehicle-specific installation instructions for part numbers

Figure 4 Typical connections with a SignalMaster controller (external control)

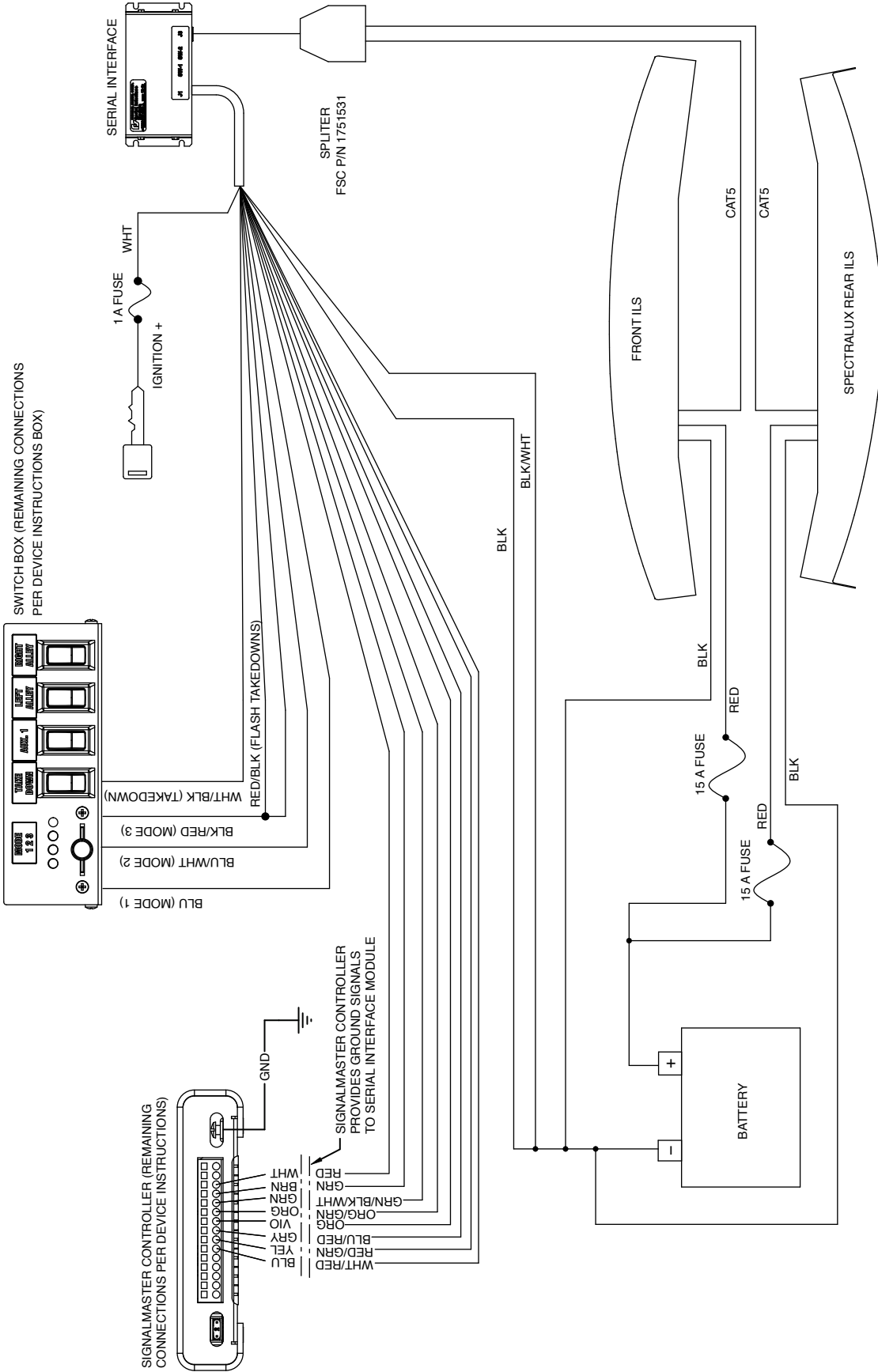

290A7047

Figure 5 Typical connections with a SmartSiren Model SS2000SM

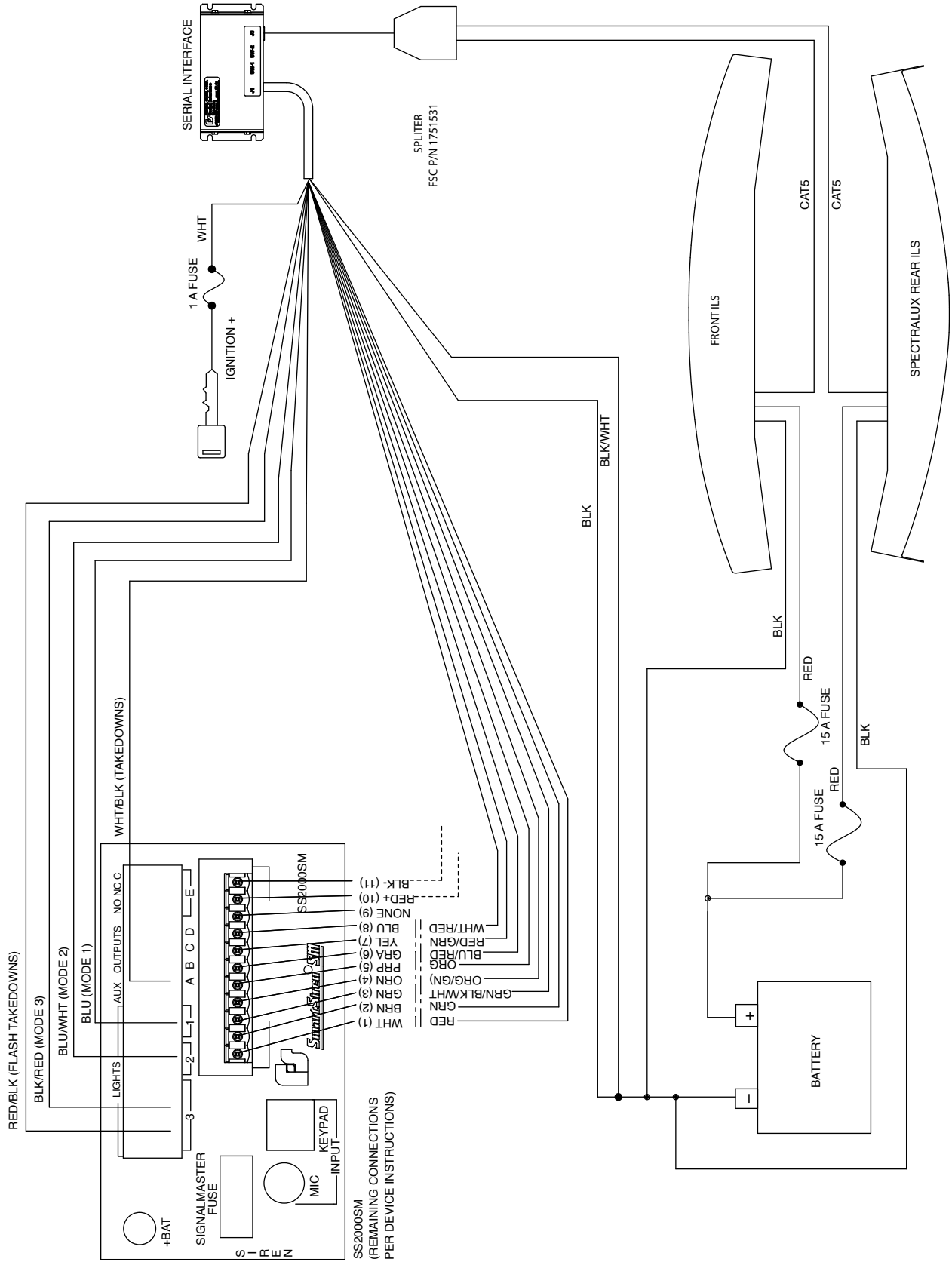

290A7046



2645 Federal Signal Drive, University Park, IL 60484-3167
Tel.: (800) 264-3578 • 708-534-3400 • Fax: (800) 682-8022
www.fedsig.com

© 2014 Federal Signal Corporation