



Executive Office  
255 E. Brown Street  
Birmingham, MI 48009  
Phone: 248-433-1824  
Fax: 248-433-1824  
Fax2: 248-594-3433

Machine Division  
3110 Permawick Drive  
Columbus, IN 47201  
Phone: 812-376-0703  
Fax: 812-376-8305

---

# PERMAWICK

## The Industry Standard for Fractional Horsepower Motor Lubrication

---

**Service Manual**

**for the**

**ST 1-802**

**Permajector**

SERVICE MANUAL - ST 1-802  
SINGLE STATION PERMAJECTOR

## Table of Contents

Machine Setup and Operation	1, 2
Power Connections/Electrical Panel	3
Controls	4
Air System Connections	5
Permawick Hopper	6
Metering System	7
General/Preventive Maintenance	8
Troubleshooting Guide	9
Service Policy	10
Seal Chart	11
Standard Cycle	12, 13, 14

## **Machine Setup and Operation**

Remove the Permajector from shipping crate and place it level on the floor. It is not advised to use the shipping skid as a machine base.

Connect air supply to the Filter-Regulator-Lubricator (see page 5) and maintain approximately 80 to 90 PSI. A fitting to adapt to your air system may be required.

Using at least one bucket of Permawick to start with, place the bucket upside down on the floor for 15 to 30 minutes before putting the Permawick in the hopper. This will provide even distribution of oil throughout the Permawick material.

Note: Never exceed a total of 2 buckets in the Hopper (see max. fill level page 6).

Connect electrical supply (see page 3). Power to supply the Permajector is usually 480 Volts (3 Phase) unless a different voltage is specified (Ex: 380V).

After power is connected, turn the machine on and open the top door to the hopper, viewing the stirring paddle rotation direction during MORNING START cycle.

If the stirring paddle is rotating counter-clockwise, it will be necessary to switch two of the input supply wires; reversing polarity. Be sure to turn off the main power disconnect switch first.

To operate the machine after the MORNING START cycle is complete:

1. With no parts on the holding fixture, only a towel, cycle the machine 3 times. Then clean nozzle with air or wipe with a clean towel. Do not use the Permawick material that has been shot into the towel; it must be disposed of.
2. Remove towel, and place the designated endshield and associated parts on the holding fixture; noting proper orientation (see tooling assembly drawing).
3. To operate, press both CYCLE buttons and hold momentarily, then release.
4. After the injection is complete, remove part from fixture and repeat.

If you plan to relocate the Hopper from the Permajector machine, or you have purchased a stand alone inject station and Hopper; the following are important guidelines to follow.

1. Always try to locate the Hopper as close as possible to the Metering System, preferably 2 to 4 feet; do not exceed 10 feet. Long runs can cause pumping and injection problems.
2. Use steel hydraulic tubing 5/8 inch minimum diameter at .042 - .060 inches thick. A high quality steel-braided hydraulic hose with Teflon lining could be used for short runs if necessary, but is not recommended. The hose could deteriorate over time and can cause plugging and injection problems.
3. Minimize the number unions used, and number of bends in the tubing. Avoid sharp corners when forming the tubing, a 3 to 6 inch radii is recommended.
4. Avoid using reducers and adapters when possible. **Never use 90 degree fittings !**  
If it becomes necessary to use a reducer, and the Permawick is to flow through a smaller diameter, you must then chamfer the small diameter at least to match the large diameter to prevent plugging.

Use the following chart to reference the type of Metering System being utilized.

Metering System	Tubing sizes
800-2	5/8" dia. input line, and 5/8" dia. return line*
800	3/4" dia. input line, and 3/4" dia. return line**
802	3/4" dia. input line, and 3/4" dia. return lines
804	3/4" dia. input lines, and 5/8" dia. return lines
804-2	5/8" dia. input lines, and 5/8" dia. return lines

\* For 800-2 applications where the hopper is located over 6 feet from the metering system, a 3/4 inch return line is recommended.

\*\* On special 800 applications, Metering Block porting and Permawick lines may be reduced to 5/8.

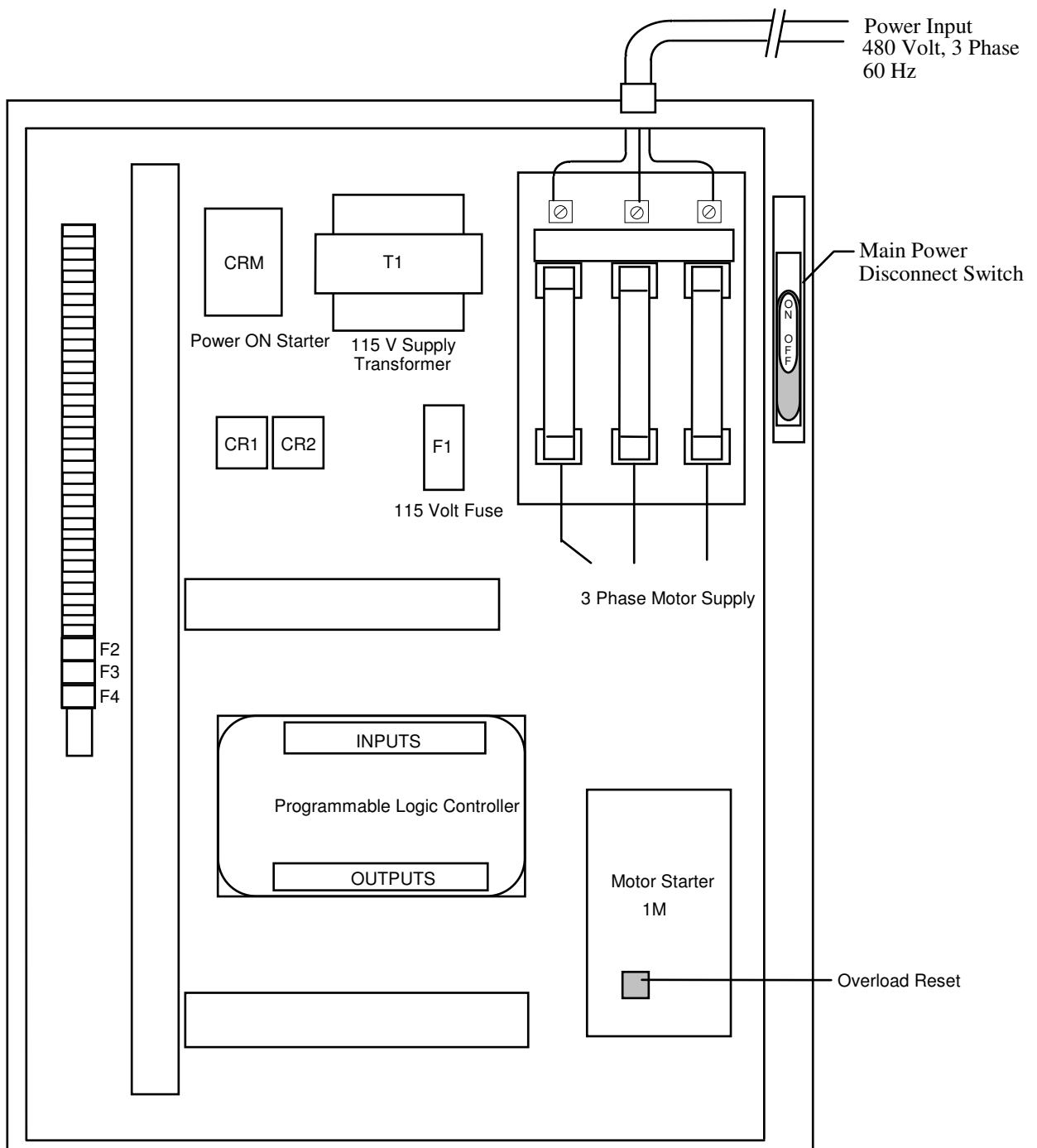

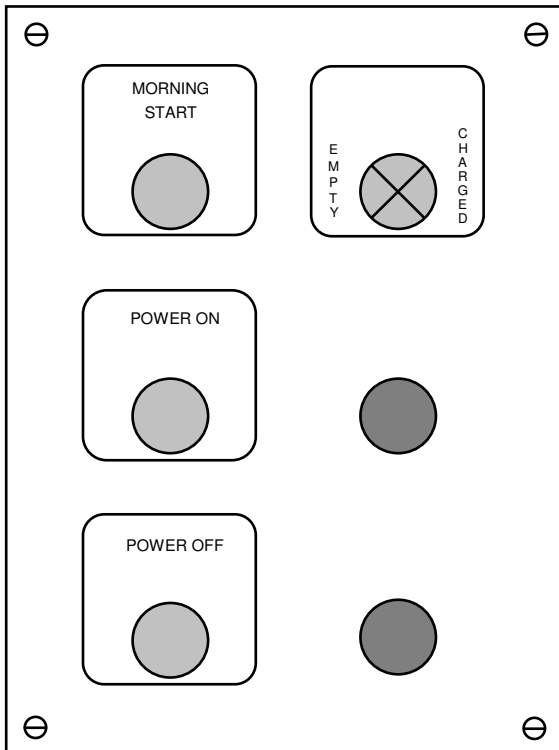

To Cycle the Permajector depress both CYCLE buttons simultaneously, then release. The anti-tie down function in the electrical program will prevent the machine from repeating the cycle.

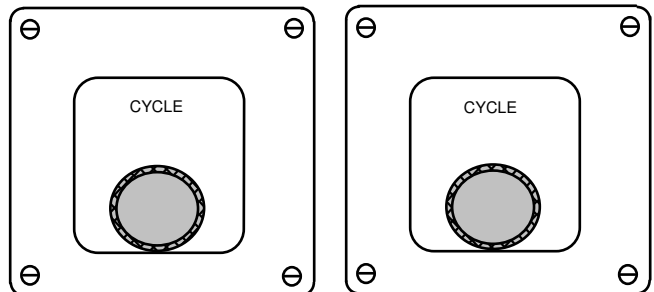

**MORNING START (Amber pushbutton)** - Cycle lasting approximately 2.5 minutes that circulates the Permawick providing even lubricant distribution throughout the material. This cycle is recommended to be used after several hours of idle-time, at the beginning of the shift, or when more Permawick is added to the hopper. This cycle can be halted by either pressing one of the green cycle buttons, or the red stop button. Also, the amber lamp will illuminate momentarily after each injection indicating the pump is on, and turns off when metering system is charged.

**EMPTY/CHARGED (Indicator lamps)** - Will illuminate to describe the current state the metering system is in. If the Metering System is empty, the red lamp will be illuminated. If the system is charged with Permawick, the green lamp will be illuminated; indicating it is ready for the next cycle.

**POWER ON (Green illum. pushbutton)** - Push on; illuminated when power is on.

**POWER OFF (Red pushbutton)** - Push to turn machine off when not in use.

## Filter-Regulator-Lubricator

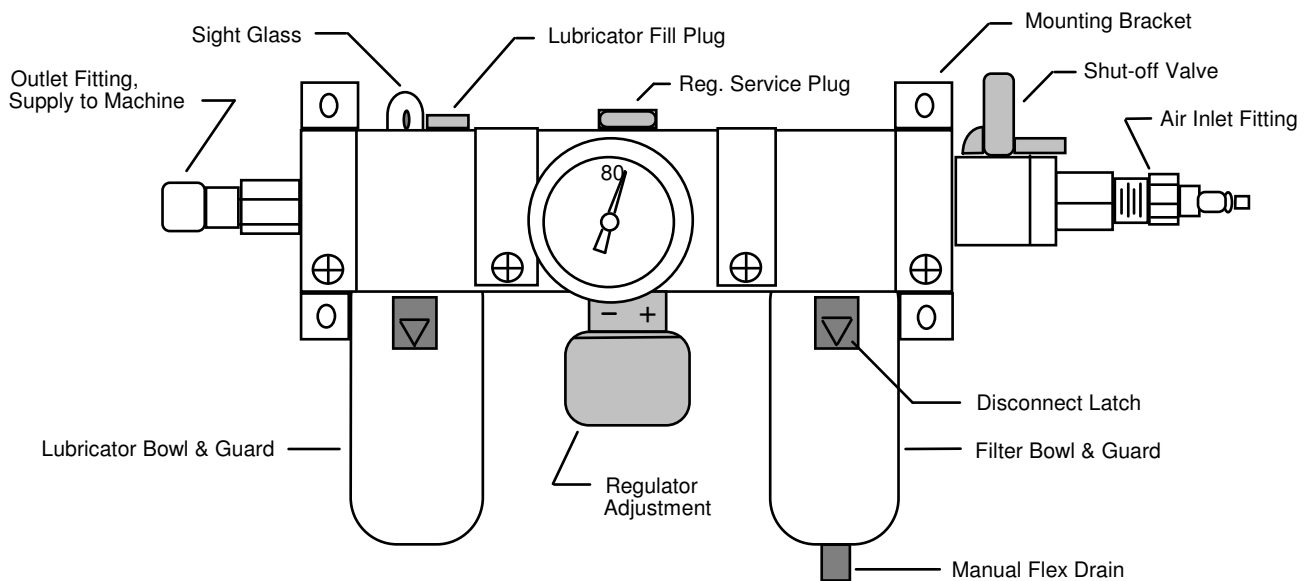

After connecting your air supply, turn the shut-off valve to the ON position. Proper air pressure (80-90 PSI) can be obtained using the regulator adjustment knob.

**WARNING !** Before performing any maintenance to the F-R-L, turn valve to the OFF position, and vent any pressure in the system.

The Filter unit will separate contaminated liquids from the air, and will collect in the bowl. The Bowl can then be cleared of liquids using the Manual Flex-Drain by pushing it to one side.

The Lubricator will continuously supply lubricant throughout the air system. Add oil to the Lubricator bowl as needed via the Fill Plug. Recommended oil is SAE-10 or similar light oil for air systems.

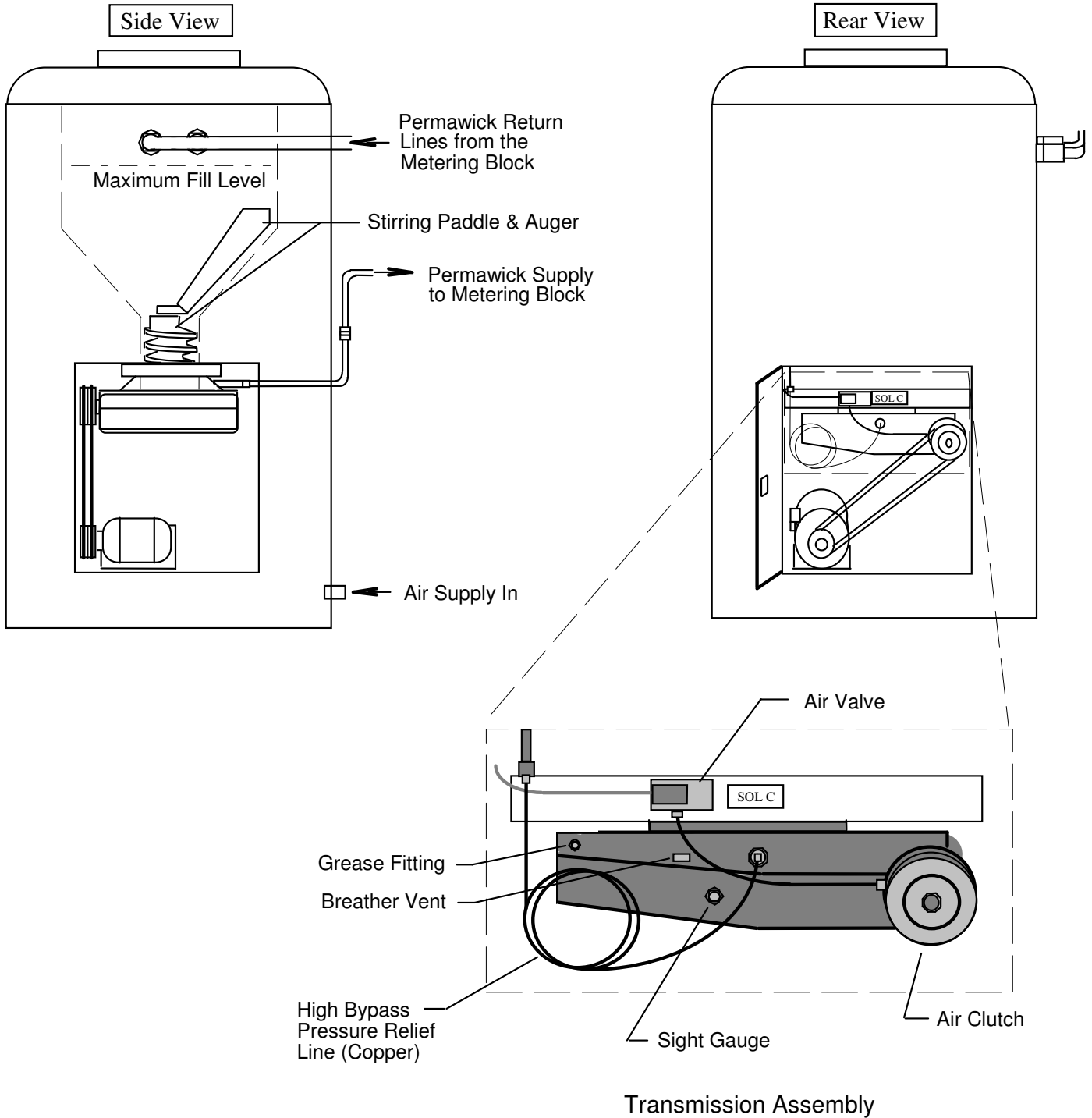

**Metering System**



The Metering System Assembly controls the amount of Permawick that will enter the endshield cavity during the injection. The amount of Permawick to be injected can be regulated by the metering system injection spacers. For example: a thinner spacer would increase the shot amount of Permawick material injected.

The top air cylinder (10149-4) on the metering system will locate the injection tooling to the endshield, then, the bottom air cylinder (10149-9) will lower and make the injection. (Refer to Sequence of Operation drawing 10240)

Holding fixtures are individually designed per application to provide a suitable nest for mating parts to be properly positioned together. Usually a rubber seal is used in the nozzle assembly and/or the fixture assembly to ensure Permawick is injected in the proper areas, and to permit proper bearing contact. Check these rubber seals for wear frequently. Replacements can be ordered from Permawick Company. See the inject tooling assembly drawings for rubber seal part numbers.

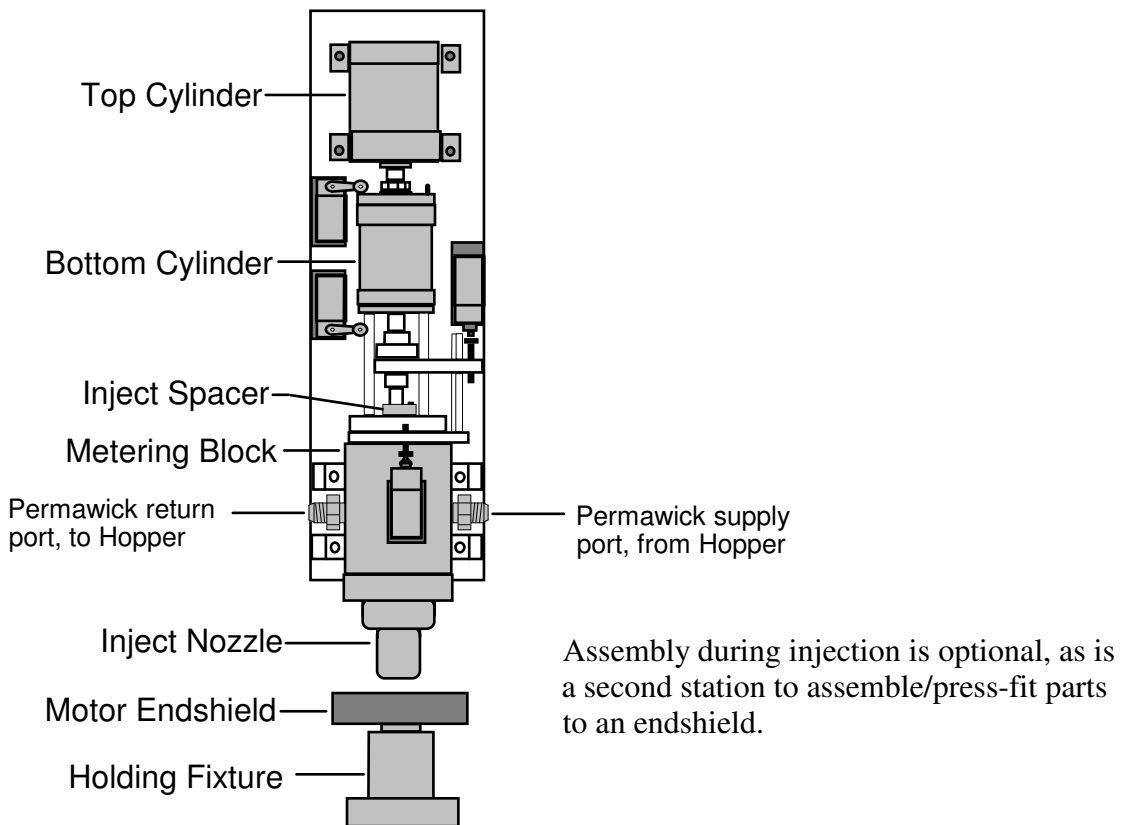

Overall, the Permajector (all components included) requires minimal maintenance. However, listed below are some typical maintenance guidelines to follow.

### Hopper/Transmission

1. Check the belts for wear and proper tension.
2. Grease fitting, apply a minimal amount only after rebuilding transmission.
3. Inspect/tighten the flathead bolts mounting the tie plate to the rod and piston.
4. The desired oil level in the transmission can be determined by inspecting the level from the sight glass window. In the event that a leak develops, use 90W grade gear oil after correcting the leak. See page 11 for seal information.
5. If the unit requires to be rebuilt, remove it from the hopper as follows:
  - a) Disconnect the Permawick supply line from the right side of the metering block, then pump the material (if possible) from the hopper into an empty yet clean container using the morning start cycle. Turn the power off.
  - b) Loosen the auger bolt and remove the stirring paddle. If a hoist is available, replace auger bolt with an eyebolt or hook assembly; then remove mounting and lower the unit - exiting through a side access panel.

### Metering System

1. If the metering block assembly is damaged/worn and requires to be rebuilt, it is strongly recommended that these components be sent to Permawick Machine Division to be remanufactured. If only the seals are worn, new seals can be ordered from Permawick.
2. To remove metering block, simply remove limit switches from backplate (leave wires connected) then, remove the metering block assembly and ship it to Permawick Machine Division in a crate.

### Electrical

1. Occasionally inspect the relay and starter contacts (CR1, CR2, CRM, M1).
2. The programmable controller is equipped with an EEPROM memory chip, which permanently contains the electrical program. Therefore, when power is removed from the machine, the program will be maintained.

I. Machine will not cycle, or will not complete the cycle:

- A) The air supply is not turned on.
- B) LS 1 (Slide Returned) is out of adjustment.
- C) Blown fuse or a bad relay.
- D) Pump motor starter overload reset is tripped.
- E) The red EMPTY lamp is on, the green CHARGED lamp is off.
  - 1. Pump did not run; metering system not charged.
    - a) The Hopper is out of Permawick.
    - b) The Charged Limit Switch (LS 4) is out of adjustment.
    - c) Slide Returned Limit Switch (LS 1) is out of adjustment.

II. Partial cycle:

- A) System lowers and stops, will not return.
  - 1. Nozzle tooling may be plugged with Permawick material.
  - 2. The Inject Advanced Limit Switch (LS 3) is out of adjustment.
- B) System will not actuate the Inject Cylinder (Cyl 2).
  - 1. Part out of location.
  - 2. Defective solenoid valve (Sol B)
  - 3. Slide Advanced Limit Switch (LS 2) is out of adjustment.
  - 4. Blown fuse or bad relay.

**Service Policy**

Components such as controls, air valves, air cylinders, limit switches, and the hopper

motor, are all standard parts that can be easily obtained from industrial suppliers. Parts for the hopper assembly, transmission/pump, and metering system must be ordered from the Permawick Company.

Replacement parts for the hopper assembly and metering system will be covered under a 1 year warranty by Permawick. Standard and purchased components will be warranted by Permawick for 90 days. Warranties will be voided if the damaged assembly has been tampered with.

It is not recommended that a Permawick customer attempt major repairs to a metering system, rotary nozzle unit, or the transmission/pump assembly. Although they rarely require major repair, these units usually provide ample warning of impending failure. If it is determined that an assembly is in need of remanufacture, a replacement can be purchased, then, return the unit which is damaged to Permawick Machine Division for rebuild, and the customer will only be charged for those parts that are required to restore the unit to new condition.

---

**Ordering Information:  
Permajectors, components, Permawick**

Executive Office  
Phone 810-433-3500  
Fax 810-433-1824  
32400 Telegraph Road - Suite #102  
Bingham Farms, MI 48025

**Technical Support**

Machine Division  
Phone 812-376-0703  
Fax 812-376-8305  
3110 Permawick Drive  
Columbus, IN 47201

Page 10  
SERVICE MANUAL - ST 1-802  
SINGLE STATION PERMAJECTOR

**Seal Chart  
802 Metering System**

Piston Diameter	Uneepac Seal No.	Description	Quantity Required	Order in sets	Permawick Equivelant
1"	9883	Standard	4	4 sets	10149-23
	13691	Flat Bottom	2		

### 15000 C Transmission Assembly

	Seal Numbers	Description	Quantity Required	Permawick Equivelant
Worm Shaft	8700	7/8"	2	7308-13
Auger Shaft	12336	1 1/4"	1	7308-42
Piston 1 1/2"	8919	Standard	2	7308-27
	14210	Flat Bottom	1	
Rod 1 1/4"	9901	Standard	2	7308-32
	14108	Flat Bottom	1	

Select the corresponding piston diameter for your metering system.  
When using the Permawick part number specify piston diameter.

### Permajector Standard Cycle

METERING SYSTEM IS CHARGED, LS "4" IS CLOSED.

SOL "A" ENERGIZES, ADVANCES TOOLING.

LS "1" OPENS DISABLING SOL "C".

LS "3" CLOSES.

PS "1" CLOSES - INITIATING INJECTION (SOL "B") (PRESSURE SWITCH IS ONLY USED ON THE 800-2 METERING SYSTEM)

LS "3" CLOSES - INJECTION COMPLETE - SOL "B" DE-ENERGIZES, RETURNING CYLINDER #2, THEN A 0.2 SECOND DWELL. SOL "A" DE-ENERGIZES; RETURNING CYLINDER #1.

LS "1" CLOSES - SOL "C" ENERGIZES, AND REMAINS SO UNTIL 0.5 SECONDS AFTER LS "4" CLOSES, OR UNTIL CYCLE IS RE-INITIATED.

THE SYSTEM IS SUPPLIED WITH A 2.5 MINUTE PUMPING CYCLE (MORNING START) TO MIX THE PERMAWICK AT SYSTEM START-UP, AND WHEN NEW MATERIAL IS ADDED TO THE HOPPER.

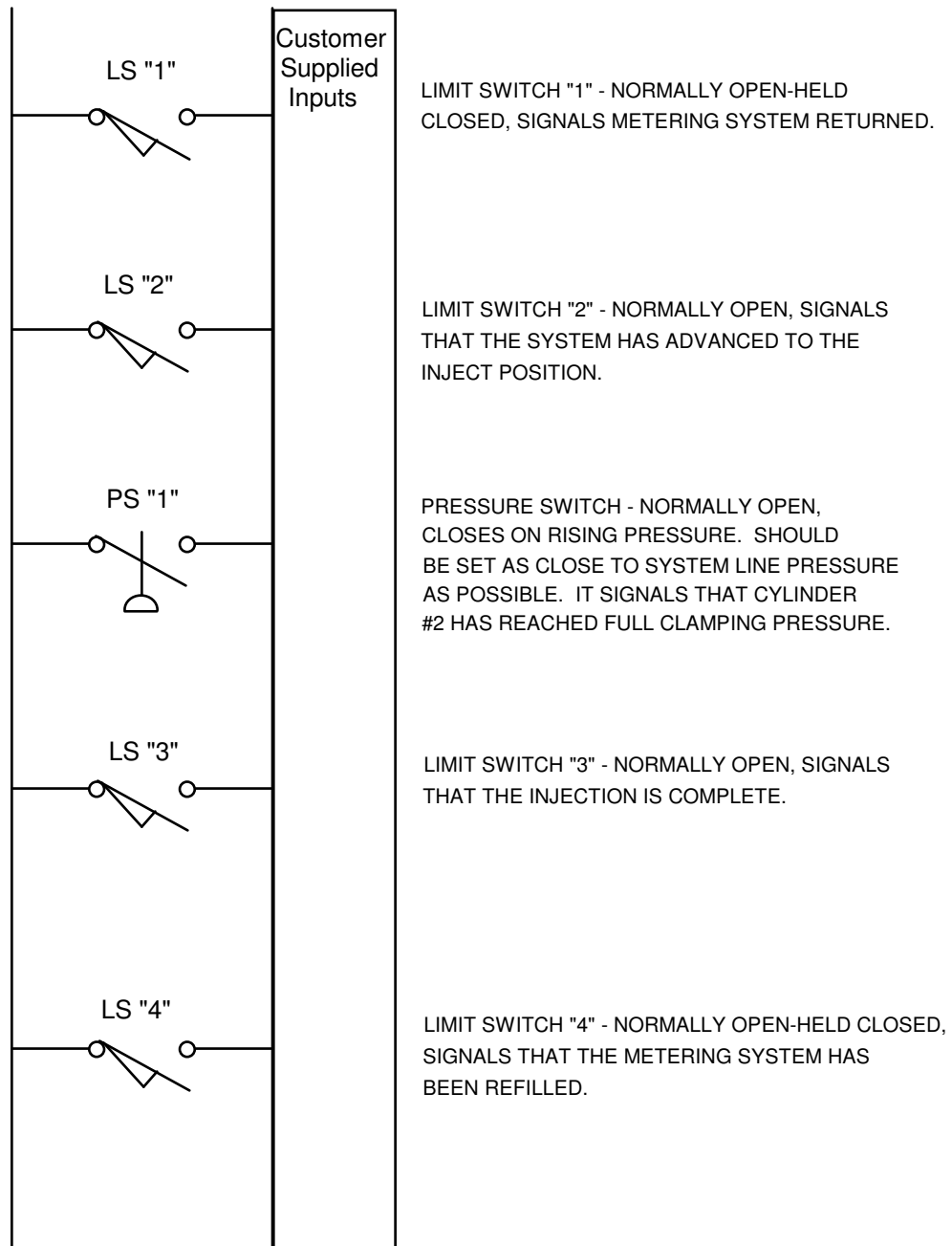

**Permajector Standard Cycle**

