



AV09-4WL

Solar Windsock Light Kit

Installation & Service Manual



AV09-4WL

Solar Windsock Light Kit

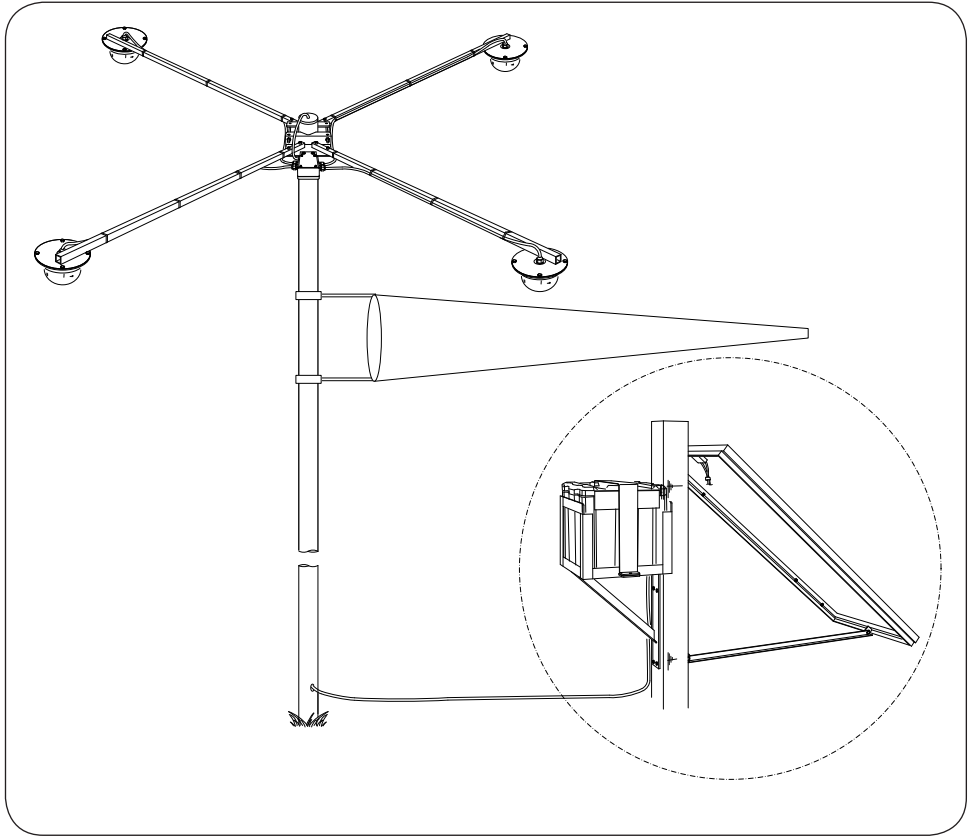

Figure 1 AV09-4WL Solar Windsock Light Kit
(Shown with windsock. Avlite does not supply the windsock)

Table of Contents

Introduction	4
Operating Principle	4
Technology	4
AV09-4WL Model	5
Optional Configurations	5
Assembly & Installation	6
Assembly of the Solar Panel & Mounting Frame	6
Unpacking Instructions	6
Initial Inspection	6
Assembly	6
Installation of the Solar Panel & Battery Box Cage	8
Unpacking Instructions	8
Initial Inspection	8
Assembly	8
Installing the Solar Panel & Battery Box Cage	10
Installation of the Battery & Battery Box	12
Unpacking Instructions	12
Initial Inspection	12
Installing the Battery Box	12
Regulator Connection & Operation	14
Regulator Connection Order	14
Selecting Lighting Control Option	14
Day/Night Transition	15
LED Indicators	15
Assembly & Installation of the Solar Windsock Light	16
Unpacking Instructions	16
Initial Inspection	16
Installation	16
Wiring of Completed Windsock Light Assembly	19
Unpacking Instructions	19
Initial Inspection	19
Wiring of Windsock Light	19
Maintenance & Servicing	23
Trouble Shooting	24
Avlite Light Warranty	26

Version No.	Description	Date	Approved
00	Manual Launch	13 Feb 2005	C. Procter
01	Installation Details Updated	23 March 2006	C. Procter
02	Note added to Assembly & Installation, washers added to Fig 5, style of battery change to Fig 7, spring washers added to Fig 8, appendix added (wiring schematic)	15 Aug 2007	C. Procter
1.3	Tech Drawing Update	27 July 2010	K. Paton

Introduction

Congratulations! By choosing to purchase an Avlite light, you have become the owner of one of the most advanced solar LED airfield lights in the world.

Avlite Systems draws on more than 25 years experience in the design and manufacture of navigation aids, and particular care has been taken to ensure your light gives years of trouble free service.

As a commitment to producing the highest quality products for our customers, Avlite has been independently certified as complying with the requirements of ISO 9001:2000 quality management system.

By taking a few moments to browse through this booklet, you will become familiar with the versatility of your light, and be able to maximise its operating function.

Please remember to complete the Avlite warranty registration card accompanying your light.

Operating Principle

The solar module of the light converts sunlight to an electrical current that is used to charge the battery. The battery provides power to operate the light at night.

The flasher unit has very low current requirements. A microprocessor drives an array of ultra bright LED's through a DC/DC converter, which enables the LED's to operate within the manufacturer's specifications. The battery is protected from over-charging within the circuit to ensure maximum battery life.

On darkness, the microprocessor will initiate a program check and after approximately 1 minute will turn on.

Technology

Avlite Systems is a world-class solar lighting systems manufacturer with a proven reputation for rapid, innovative, and agile technology solutions designed specifically for defense, government, civil and humanitarian aid operations in the most remote, toughest environments.

Electronics

Avlite employs leading in-house electronic engineers in the design and development of software and related circuitry. All individual electronic components are sourced directly by Avlite procurement staff ensuring that only the highest quality components are used in our products.

LED Technology

All aviation lights use the latest advancements in LED (Light Emitting Diode) technology as a light source. The major advantage of LED's over traditional light sources is well established in that they typically have an operational life in excess of 100,000 hours, resulting in substantial savings to maintenance and servicing costs.

Precision Construction

Commitment to investing in the design and construction of injection-moulded parts including optic lenses, light bases and a range of other components ensures that all Avlite products are of a consistent and superior quality.

Optical Performance

Avlite manufactures a range of aviation LED lenses moulded from multi-cavity dies. Complex shapes such as the AV70 and 16-segment multi-focus lenses are a testament to the company's superior in-house lens manufacturing capabilities and outstanding optical performance.

Award-winning, Patented Technology

Several United States and Australian patent registrations are held on Avlite's range of innovative designs, with other regional patents pending in Canada, United Kingdom and Europe.

AV09-4WL Model

The light source for the AV09-4WL is a high intensity 3watt LED with an appropriate current control driving circuit. Four lighting arms spaced at 90 degrees apart and facing downwards over the windssock provide clear illumination of the windssock position.

A master light controller enables activation of the lights once the light level falls to a predetermined level.

Power to the lights is provided by 2x 55Ah 12volt SLA batteries. This battery is recharged each day by a 140watt solar module. A 10amp solar regulator is fitted between the solar module and the battery to ensure the battery is charged correctly and to prevent over charging.

The solar module charging is critical to reliable ongoing operation. It must face the midday sun and be clear of shadowing by trees or obstructions.

SPECIFICATIONS •

Light Characteristics

Light Source	4 x domed luminaires each with 1x 3watt ultra-high intensity surface-mounted LED
Available colours	White
Horizontal & Vertical Divergence (degrees)	120
LED Life Expectancy (hours)	>100,000

Electrical Characteristics

Current Draw (mA)	1000
Circuit Protection	Polarity protected
Operating Voltage (v)	12
Temperature Range	-40 to 80°C

Solar Characteristics

Solar Module Type	Multicrystalline
Output (watts)	140
Solar Module Efficiency (%)	15
Charging Regulation	Controller

Power Supply

Battery Type	SLA (Sealed Lead Acid)
Battery Capacity (Ah)	2 x 55Ah
Nominal Voltage (v)	12
Autonomy (nights)	8

Certifications

CE	EN61000-6-3:1997. EN61000-6-1:1997
Quality Assurance	ISO9001:2000

Intellectual Property

Trademarks	AVLITE® is a registered trademark of Avlite Systems
Warranty *	Full 3 year warranty

- Specifications subject to change or variation without notice
- Subject to standard terms and conditions



Optional Configurations

Optional Radio Controlled (AV09-4WL-RF)

The Avlite Solar Windssock Light Kit is also available with Radio Control, whereby lights can be operated by a wireless handheld controller, which enables personell to remotely activate the lights.

Optional External ON/OFF Switch (AV09-4WL-S)

The Avlite Solar Windssock Light Kit can be fitted with an external ON/OFF switch. The ON/OFF switch may be useful if the unit is only required for short periods and disconnecting the battery is not viable.

Optional Avlite Pilot Activated Lighting Control

The Avlite Solar Windssock Light Kit can be integrated to a third party Pilot Activated Lighting Controller (AV-PALC), to allow approaching aircraft to activate lighting on unmanned aerodromes.

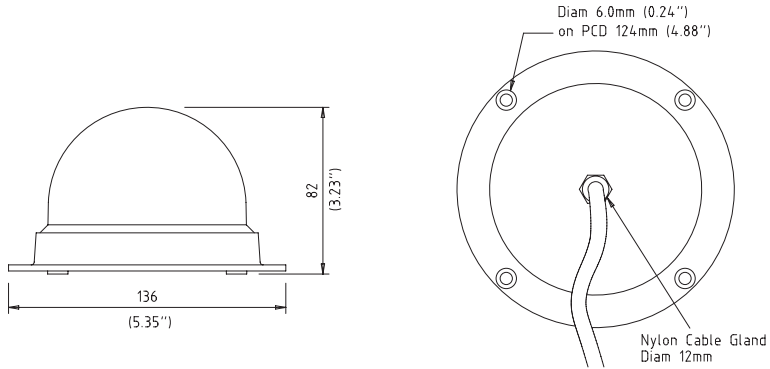

Figure 2 Leading Dimensions of AV09

Assembly & Installation

The installation of the AV09-4WL Solar Windssock Light includes the following steps:-

- Unpacking
- Initial Inspection
- Assembling the solar panel and mounting frame
- Installing the battery box cage and solar panel
- Installing the battery with battery box
- Assembling and installing windssock lights
- Wiring of completed assembly

Assembly of the Solar Panel & Mounting Frame

Tools required

- Adjustable spanner
- 6mm Allen key

Unpacking Instructions

Unpack all hardware and verify container contents in accordance with Figure 3 “Assembly of Solar Panel and Mounting Frame”. Please contact your Avlite office if there is any hardware missing.

Initial Inspection

Inspect all hardware for damage. If there is any damage, please contact your Avlite Office.

Note:- If the solar panel and mounting frame have been supplied pre-assembled then proceed to ‘Installation of the Solar Panel & Battery Box Cage’ section of this manual.

Assembly

Refer to Figure 3 “Assembly of Solar Panel and Mounting Frame”.

Assembling the panel & frame

The 120W Solar Panel (Ref 3.1) is attached to the Mounting Frame (Ref 3.2) using bolts (Ref 3.3), washers (Ref 3.4) and nuts (Ref 3.5).

- a. Insert bolts through the holes in the mounting frame, entering from the side of the angle.
- b. Fit the Solar Panel flush against the Mounting Frame.
- c. Install a washer and a self locking nut on each bolt. Tighten using spanner.

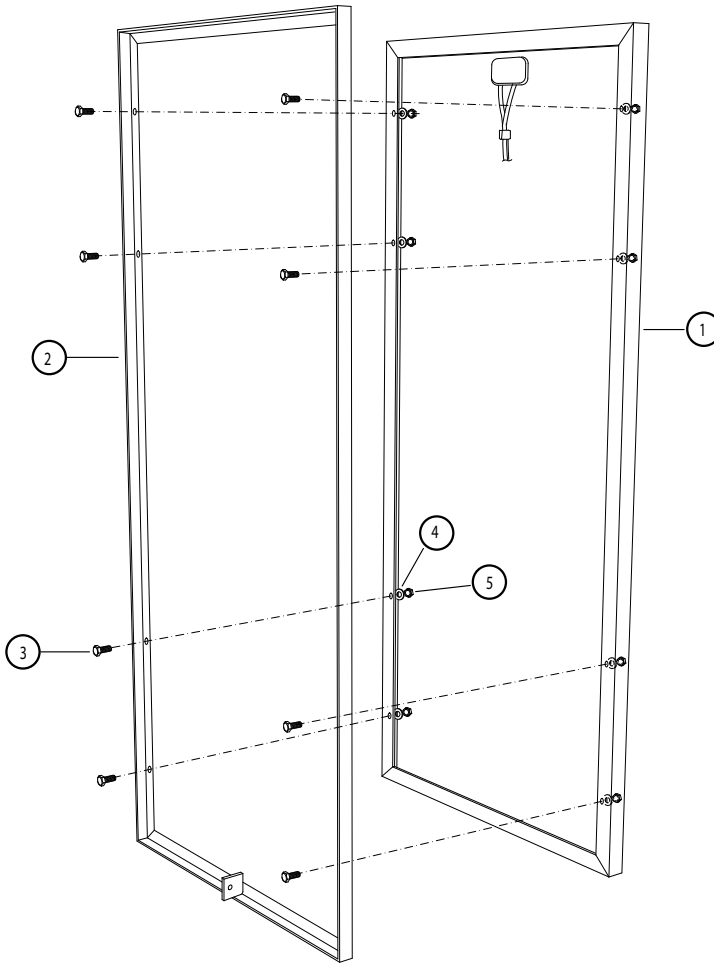

Item	Description	Qty
3.1	140W Solar Panel	1
3.2	Solar Panel Frame	1
3.3	Bolt, 8mm x 20	8
3.4	Washer, 8mm	8
3.5	Self Locking Nut, 8mm	8

Figure 3 Assembly of Solar Panel & Mounting Frame

Installation of the Solar Panel & Battery Box Cage

Tools required

- Digging implement (for post)
- Under size drill for 12mm screws
- Spanner

Unpacking Instructions

Unpack all hardware and verify container contents in accordance with Figure 5 “Installation of Solar Panel & Battery Box Cage”. Please contact your Avlite office if there is any hardware missing.

Initial Inspection

Inspect all hardware for damage. If there is any damage, please contact your Avlite Office.

Installation

Refer to Figure 4 “Panel & Cage Footprint” and Figure 5 “Installation of Solar Panel & Battery Box Cage” during installation of the panel and cage.

Installing the Post

A suitable mounting point for the Solar Panel and Battery Box Cage is to be provided by the client. It is usual to use a purpose installed post. The following should be observed:-

- The post should be of a durable timber, or other durable material.
 - Recommended minimum post size is 150mm x 150mm, or larger if the Battery Box Cage needs to be installed immediately beneath the Solar Panel.
 - The length of post required is the sum of exposed length (normally 1.25m) plus the required depth into the ground which is dependant on local soil conditions (recommended depth 850 minimum).
 - The Solar Panel is to face south if installed in the northern hemisphere and north if in the Southern hemisphere. Therefore, faces of the post must be aligned with the cardinal points of the compass.
 - The post should not be more than 20m from the windssock post, and should not be located so as to place the Solar Panel in shade for a significant time.
 - The Solar Panel is tempered glass, so the post should be located away from any objects which might fall on the installation.
 - The post and equipment footprint should be at least 300mm clear of the windssock itself under all conditions.
- a. If you are mounting the Panel and Cage on a post, then dig a hole and install the post in the chosen location.

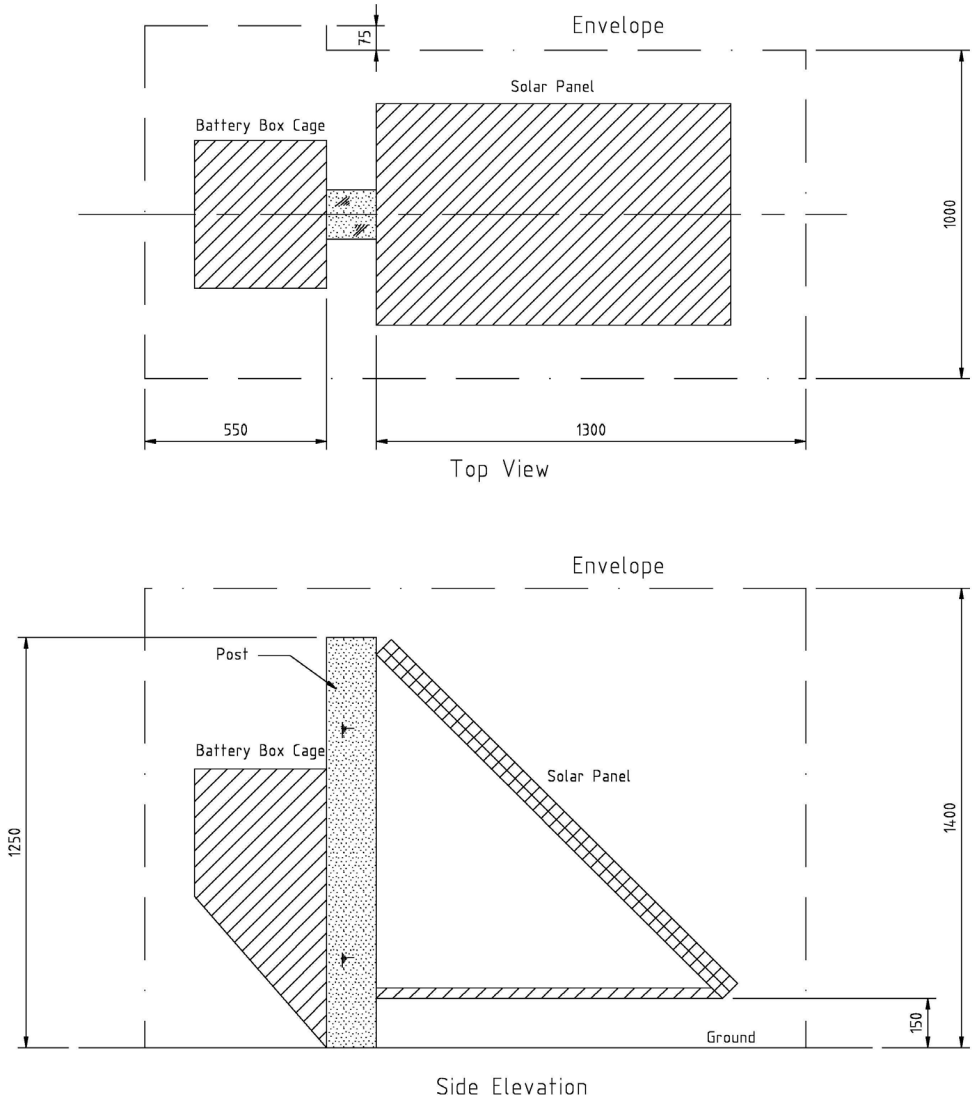

Figure 4 Panel & Cage Footprint

Installing the Solar Panel & Battery Box Cage

The Battery Box Cage (Ref 5.2) and the steel support bracket (Ref 5.4) are attached to the post (Ref 5.3) using coach screws and washers (Ref 5.6, 5.7).

- a. Drill the post for the steel support bracket (6 places) and install.

Important: - The Solar Panel is to face south if installed in the northern hemisphere and north if in the southern hemisphere. Locate the solar panel support bracket accordingly.

- b. Drill the post for the Battery Box Cage (6 places) on the opposite side to the solar panel and install.
- c. Install the solar panel and frame (Ref 5.1) and the Brace (Ref 5.5) to the steel support bracket using bolts (Ref 5.8), washers (Ref 5.9) and nuts (Ref 5.10).

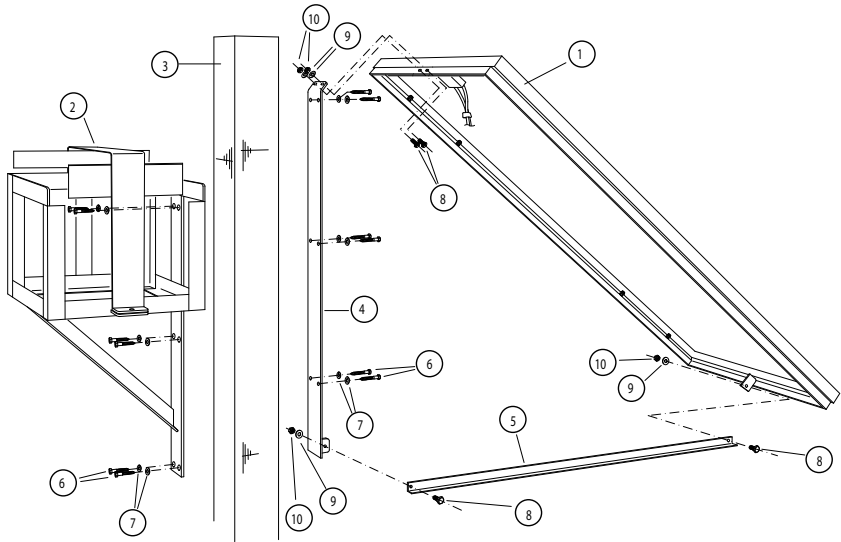

Item	Description	Qty
5.1	140W Solar Panel & Frame	1
5.2	Battery Box Cage	1
5.3	Post, 150x150 minimum	Client Supplied
5.4	Steel Support	1
5.5	Steel Brace	1
5.6	Screw, 12mm x 75	Client Supplied
5.7	Washer, 12mm	12
5.8	Bolt, 10mm x 25	4
5.9	Washer, 10mm	4
5.10	Self Locking Nut, 10mm	4

Figure 5 Installation of Solar Panel & Battery Box Cage

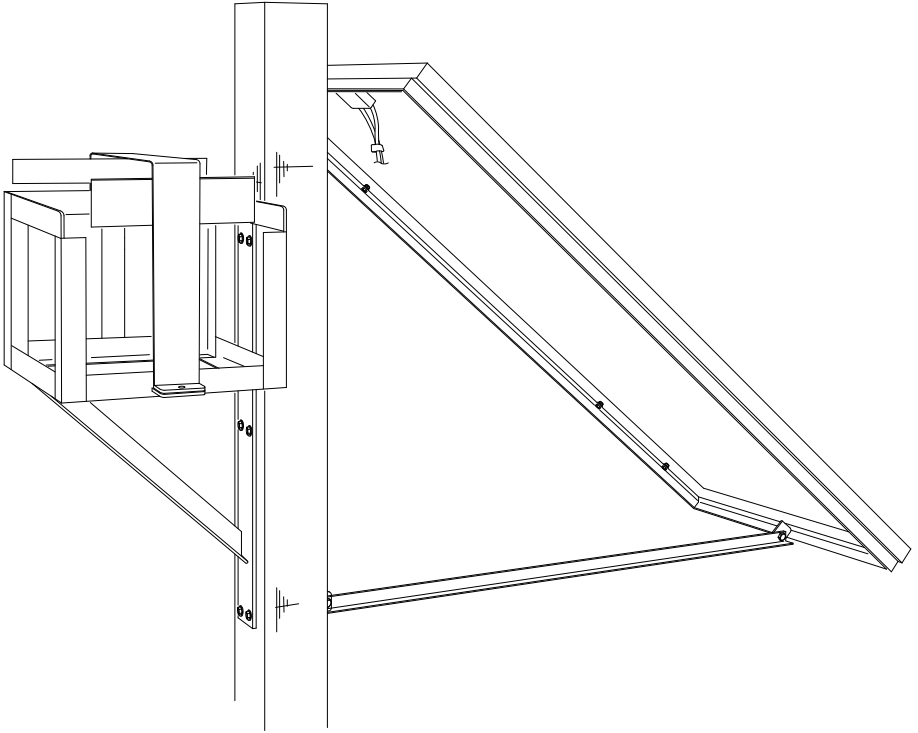

Figure 6 Solar Panel & Battery Box Cage



Installation of the Battery & Battery Box

Tools required

- Spanner

Unpacking instructions

Unpack all hardware and verify container contents in accordance with Figure 7 “Battery and Battery Box”. Please contact your Avlite office if there is any hardware missing.

Initial inspection

Inspect all hardware for damage. If there is any damage, please contact your Avlite Office. Retain original packing material for possible future use in shipping the AV09-4WL.

Installing the Battery Box

Refer to Figure 7 “Battery and Battery Box” during installation of the Battery and Battery Box.

- Open the battery box cage door and place the battery case (Ref 7.1) into the cage with the hinge of the case adjacent to the hinge of the cage.
- Open the battery case and lower the battery into the case ensuring the battery terminals are upright.
- Insert one bolt (Ref 7.3) with a washer (Ref 7.4) under the head through each of the battery terminals.
- Connect Battery (-) cable from the solar regulator to the Battery (+) terminal
- Connect Battery (+) cable from the solar regulator to the Battery (-) terminal
- Connect Solar (-) cable from the solar regulator to the Solar (-)
- Connect Solar (+) cable from the solar regulator to the Solar (+)
- Connect Load (-) cable from the solar regulator to the light (-)
- Connect Load (-) cable from the solar regulator to the light (+)

Note: *The regulator connection points are numbered. Please follow the sequence for correct installation.*

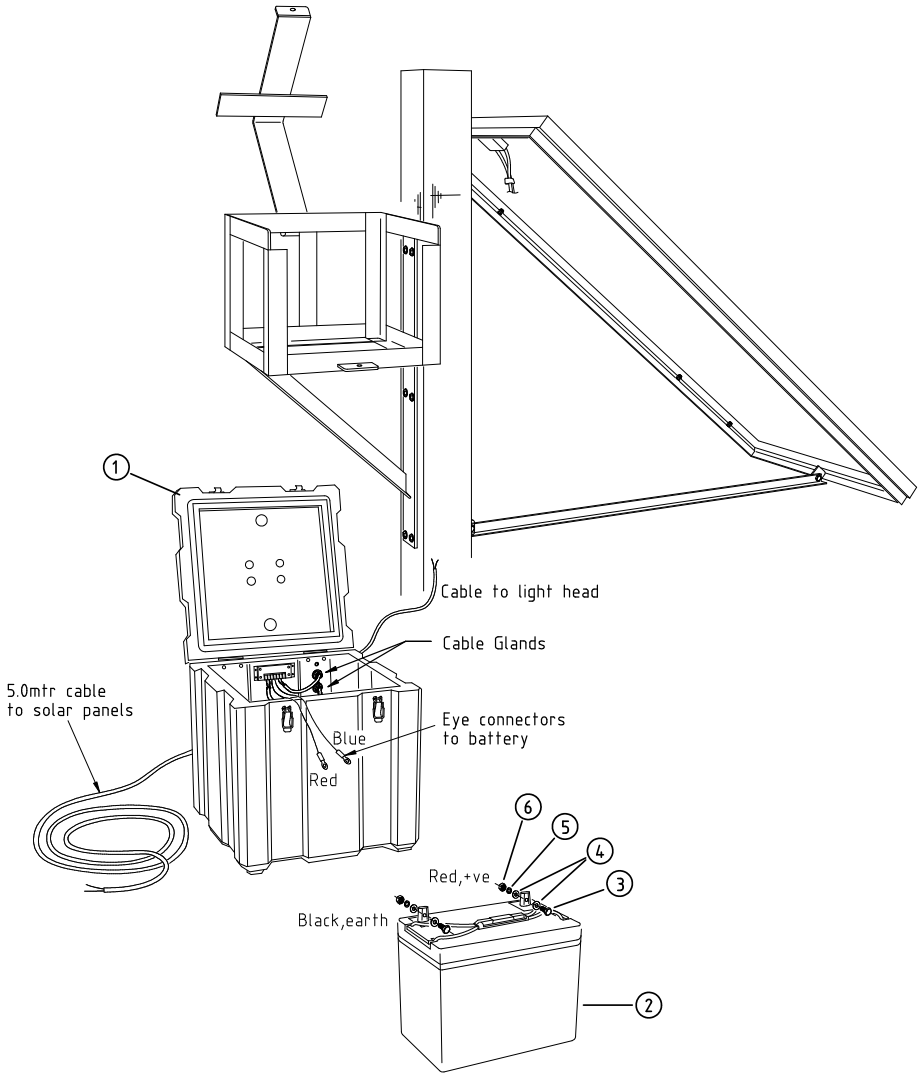

Item	Description	Qty
7.1	Battery Case, SPC353534	1
7.2	Battery, 12V 70AH or equivalent	1
7.3	Bolt, battery	2
7.4	Washer, battery	4
7.5	Spring Washer, battery	2
7.6	Nut, battery	2

Figure 7 Battery and Battery Box

Regulator Connection & Operation

Regulator Connection Order

The label on the Regulator has each system connection labelled from 1 to 6. This is the recommended order of system connections.

IMPORTANT: The BATTERY must be connected before the SOLAR to properly start the microcontroller.

1. BATTERY: Connect the battery (+) and battery (-) to the Regulator
2. SOLAR: First, be certain the battery (+) and battery (-) is connected correctly. Then connect the solar array to the SOLAR terminals.

Selecting Lighting Control Option

After completing the system connections, select the desired LIGHTING CONTROL option.

A brief description is as follows:

- | | |
|----------------|--|
| OFF | Lights remain turned off |
| 2, 4, 6, 8, 10 | Hours light is turned off after sundown |
| 3/1, 4/2, 6/2 | Light is turned on after sundown, turned off during the night, and turned on again one hour (3/1) or two hours (4/2, 6/2) before sunrise |
| D/D | Dusk-to-Dawn, light is on all night |

The factory setting of the light is D/D (Dusk-to-Dawn).

To select a lighting option, turn the rotary digital switch to the desired position. An arrow in the rotary switch will point to the selected position. This is a digital switch, so it will click into each of the ten positions.

To confirm correct selection of the desired control option, press the TEST button located below the rotary switches.

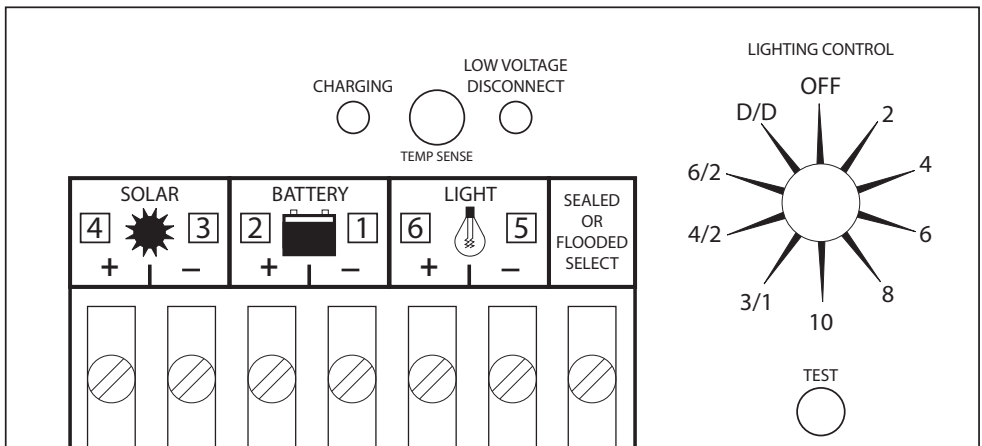

Regulator Diagram



Day/Night Transition

The Regulator uses the solar array to detect day and night. The transition to night requires the level of solar radiation being received to be less than 2 percent. The transition back to day requires a high solar array open-circuit voltage. Both state changes require 10 minutes of continuous transition values before making change. These constraints avoid false transitions due to lightning or dark storm clouds.

LED Indicators:

Green LED

The green LED indicator will light whenever sunlight is available for battery charging. The green LED will turn off at night.

Because the Regulator uses a PWM constant voltage charging process, there is usually some amount of energy going into the battery at all times. Although the charging current falls to very low levels when the battery reaches full charge, the green LED will continue to stay ON all day. This is to indicate that the controller is working and that energy is available from the PV array for charging.

Red LED

The red LED is an indicator for 3 different functions:

- **Automatic low voltage load disconnect (LVD)**
If the battery charge state falls below the LVD setpoint, the light will be disconnected and the red LED will light. This indicates the controller has disconnected the load to protect the battery from further discharge and possible damage. The red LED will turn off when the battery recovers to about 50% of its rated capacity and the load is automatically reconnected.
- **Initial controller start-up**
When the regulator is properly connected to the battery, the red LED will flash 3 times.
- **Confirm lighting control selection**
When the TEST button is pressed, the red LED will confirm the lighting control option selected by the rotary switch.



Assembly & Installation of the Solar Windssock Light

Tools required

- Spanner

Unpacking Instructions

Unpack all hardware and verify container contents in accordance with Figure 8 “Windssock Light Arm & Mounting Bracket”. Please contact your Avlite Systems office if there is any hardware missing.

Initial Inspection

Inspect all hardware for damage. If there is any damage, please contact your Avlite Systems Office. Retain original packing material for possible future use in shipping the AV09-4WL.

Installation

Refer to Figure 8 “Windssock Light Arm & Mounting Bracket” during installation of the windssock light.

Assembling the Windssock Light Arms

Windssock Light Arms (Ref 8.2) and AV09 Lights (Ref 8.3) are assembled using bolts (Ref 8.4), spring washers (Ref 8.5) and plain nuts (Ref 8.6).

- a. Insert bolts through the light arm and AV09 from above. Fasten using spring washers and nuts. (4 places). Repeat for four complete light-arm assemblies.

Installing the Windssock Light on the Windssock Post

Light arms are attached to the main windssock post using windssock light mounting brackets (Ref 8.7). In locating the mounting brackets consider the following:-

- The lights are fixed and are not meant to turn with the windssock.
 - Lights should be mounted far enough above the windssock to avoid having the windssock foul on the lights.
 - The supplied mounting brackets (Ref 8.7) will accommodate a post size from approximately 50mm to 175mm.
 - Provision is required for the power supply cable (approx 8mm diameter) to run from the power supply past the wind sock and up to the lights. This is most easily achieved by running the supply cable down through the middle of the main windssock post and out through a hole near the base.
- a. Locate the windssock light mounting brackets on the windssock post and clamp using screwed rods (Ref 8.8) with washer (Ref 8.9), spring washer (Ref 8.10) and plain nut (Ref 8.11) on each end of each rod.
 - b. Fit light-arm assemblies to the mounting brackets using bolts (Ref 8.12), washers (Ref 8.13) and self locking nuts (Ref 8.14).

Note: The preferred location for windssock lights is above the windssock.

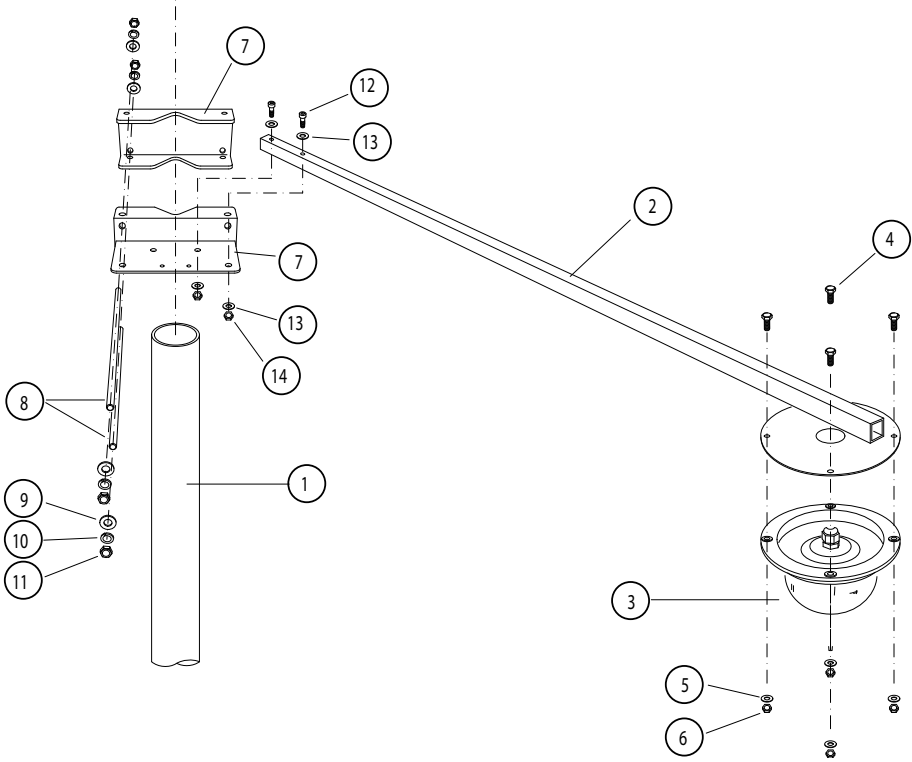

Item	Description	Qty
8.1	Windsock Post	Client Supplied
8.2	Windsock Light Arm	4
8.3	AV09 Directional LED Area Light	4
8.4	Bolt, 5mm x 20	16
8.5	Spring Washer, 5mm	16
8.6	Plain Nut, 5mm	16
8.7	Windsock Light Mounting Bracket	2
8.8	Screwed Rod, 5/16" x 300mm	4
8.9	Washer, 5/16"	8
8.10	Spring Washer, 5/16"	8
8.11	Plain Nut, 5/16"	8
8.12	Bolt, 8mm x 40	8
8.13	Washer, 8mm	16
8.14	Self Locking Nut, 8mm	8

Figure 8 Windsock Light Arm & Mounting Bracket

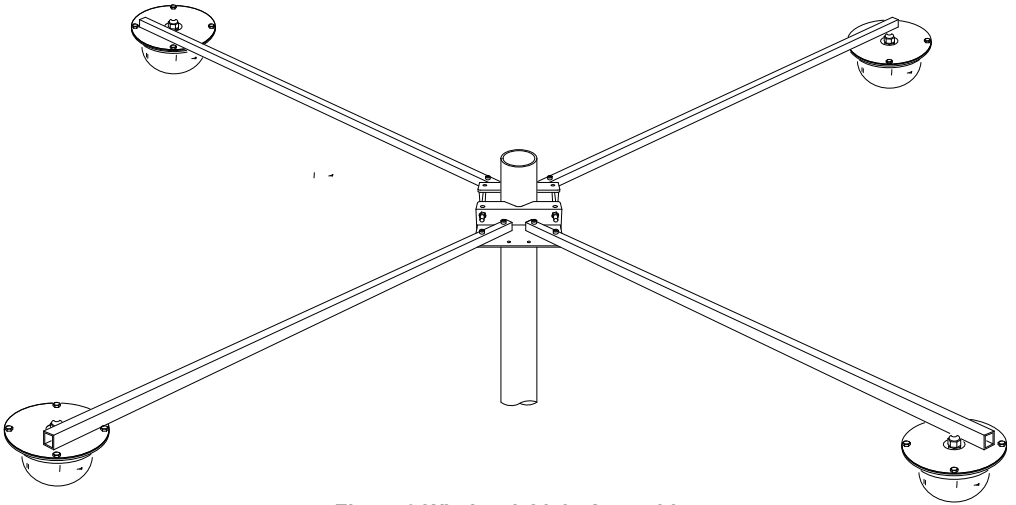

Figure 9 Windssock Light Assembly



Wiring of Completed Windsock Light Assembly

Tools required

- Spanner
- Philips head screwdriver

Unpacking Instructions

Unpack all hardware and verify container contents in accordance with Figure 10 “Windsock Light Wiring”. Please contact your Avlite Systems office if there is any hardware missing.

Initial Inspection

Inspect all hardware for damage. If there is any damage, please contact your Avlite Systems Office. Retain original packing material for possible future use in shipping the AV09-4WL.

Wiring of Windsock Light

Refer to Figure 10 “Windsock Light Wiring” during installation of windsock light wiring.

The AV09 junction box base (Ref 10.2) has four empty cable glands along its sides which are used for the AV09 power leads (Ref 10.1). The single cable exiting at the back of the junction box base is the main power supply lead which is to be routed to the battery box.

- Route the main power supply lead (coming from the back of the junction box base) down through the top of the main windsock post, out through the bottom and over to the battery box cage (Figure 6). It is preferable to run the cable through some type of rubber grommet or boot at the top of the post (client supplied) and it may be necessary to drill an exit hole near the base of the post (also with a grommet).
- Feed an AV09 power lead (Ref 10.1) through one of the empty cable glands in the junction box and join the blue bullet connector to any unused blue connector in the box. Join the red bullet connector to any unused red connector. Repeat for the remaining three AV09 power leads.
- Fit the junction box lid (Ref 10.3) to the junction box base using screws (Ref 10.4).
- Attach the completed junction box to the windsock light mounting bracket using bolts (Ref 10.5), washers (Ref 10.6) and self locking nuts (Ref 10.7).

Important: Ensure that the junction box lid is faced down.

- Secure all loose cables using nylon cable ties. Client supplied.
- Pass the lead through the remaining unused cable gland in the back of the battery case.
- Connect the main power supply cable ends to the load terminals on the solar regulator.
- Close battery case lid and engage latches. Close battery box cage door and fasten shut with nut & bolt or padlock as required (client supplied).

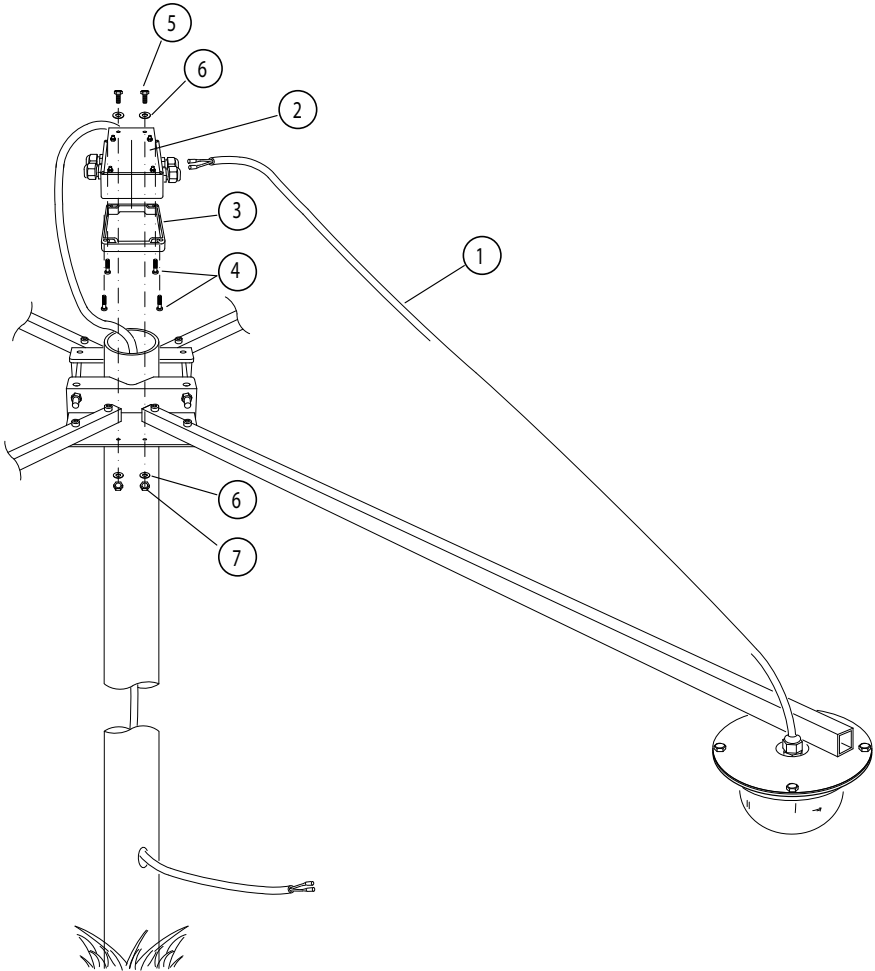

Item	Description	Qty
10.1	AV09 Power Lead, (factory fitted)	4
10.2	AV09 Junction Box, base with mount plate	1
10.3	AV09 Junction Box, lid	1
10.4	Screw, 4mm x 16	4
10.5	Bolt, 6mm x 20	2
10.6	Washer, 6mm	4
10.7	Self Locking Nut, 6mm	2

Figure 10 Windsock Light Wiring

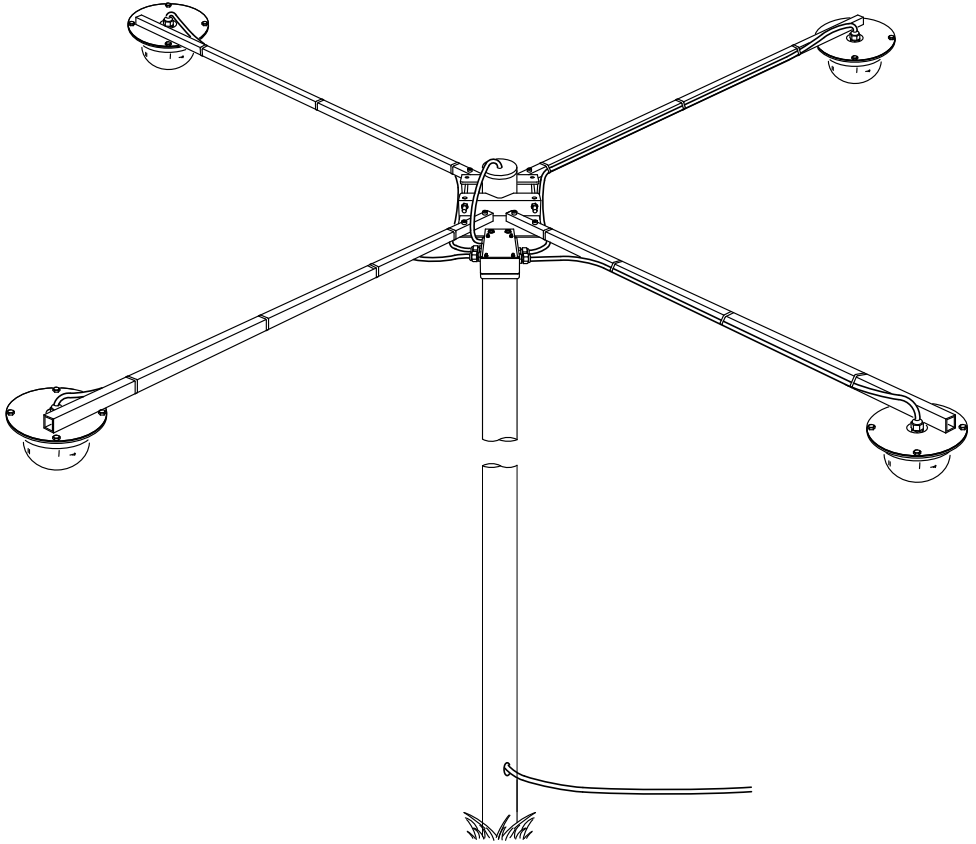

Figure 11 Completed Windssock Light Assembly

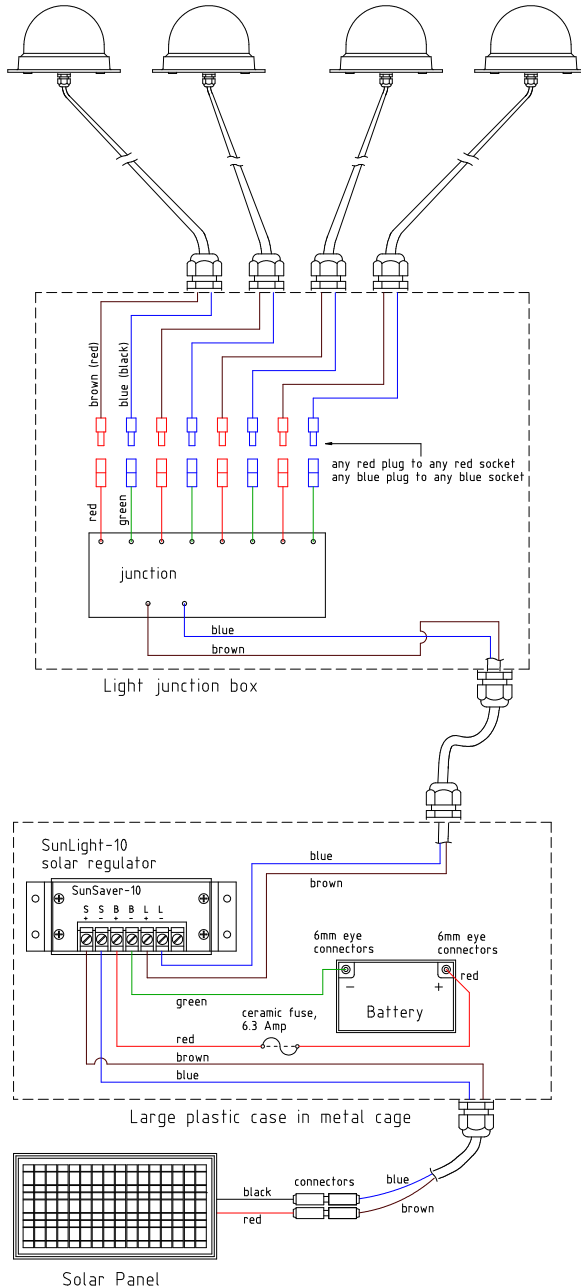

Figure 12 Wiring Schematic



Maintenance and Servicing

Designed to be maintenance free, the AV09-4WL requires minimal attention, though the following maintenance and servicing information is provided to help ensure the life of your Avlite product.

General Maintenance

a. Cleaning Solar Panels-

Occasional cleaning of the solar panels may be required. Using a cloth and warm soapy water, wipe off any foreign matter before rinsing the panels with fresh water.

b. Battery Check-

Inspection of batteries should be performed every three years (minimum) to ensure that the charger, battery and ancillary electronics are functioning correctly. Using a voltage meter, check that the battery voltage is at least 12.3 volts under 500MA load, and ensure all terminals are clear of foreign matter.

Replacing the Battery

- a. Disconnect the load
- b. Disconnect the solar
- c. Unscrew positive and negative leads and remove battery from the battery box
- d. Reattach positive and negative leads to new battery
- e. Discard old battery in a safe manner.
- f. Reconnect the solar
- g. Reconnect the load
- h. To test, place dark cover (towel or jacket) on top of light sensor junction box (ref Figure 10) to activate sensor, light will come on within about 10 seconds.

Follow the instructions for the regulator during assembly. See 'Regulator Connection & Operation' section of this manual.

Observe the polarity of the battery before the leads are re-connected to ensure the replacement battery is correctly fitted.

Trouble Shooting

Problem	Remedy
Light will not activate.	<ul style="list-style-type: none"> • Ensure battery connections are correct polarity. • Ensure lantern is in darkness. • Ensure battery terminals are properly connected. • Ensure battery voltage is above 12volts.
Light will not operate for the entire night.	<ul style="list-style-type: none"> • When the lantern is initially removed from storage the battery may be discharged and require several days of operational conditions to 'cycle' up to full autonomy. Expose lantern to direct sunlight and monitor operation for several days. Avlite products typically require an average 2.5 hours of direct sunlight per day to retain full autonomy. • Ensure solar module is clean and not covered by shading during the day. • Do not cover module with protective devices such as a steel cage as small shadows across cells reduce performance. • Batteries slowly lose capacity over time. Failure to operate for the full night may be the result of loss of capacity which means the battery must be replaced.



Notes

Avlite Light Warranty V1.0

Activating the Warranty

Upon purchase, the Avlite Systems warranty must be activated for recognition of future claims. To do this you have two (2) options:

1. **Postal Registration**

Please complete the Avlite Systems Warranty Registration Card and return to Avlite within 30 days of your purchase.

2. **Online Registration**

Please complete the Online Registration Form at; www.avlite.com

Avlite Systems will repair or replace your light in the event of electronic failure for a period of up to three years from the date of purchase.

The unit must be returned to Avlite freight prepaid.

Warranty Terms

1. Avlite Systems warrants that any Avlite aviation products fitted with telemetry equipment including but not limited to AIS, GSM, GPS or RF ("Telemetry Products") will be free from defective materials and workmanship under normal and intended use, subject to the conditions hereinafter set forth, for a period of twelve (12) months from the date of purchase by the original purchaser.
2. Avlite Systems warrants that any rotationally-moulded products ("Roto-Moulded Products") and accessory products ("Accessory Products") will be free from defective materials and workmanship under normal and intended use, subject to the conditions hereinafter set forth, for a period of twelve (12) months from the date of purchase by the original purchaser.
3. Avlite Systems warrants that any Avlite aviation products other than the Telemetry Products, Roto-Moulded Products and Accessory Products ("Avlite Products") will be free from defective materials and workmanship under normal and intended use, subject to the conditions hereinafter set forth, for a period of three (3) years from the date of purchase by the original purchaser.
4. Avlite Systems will repair or replace, at Avlite's sole discretion, any Telemetry Products, Roto-Moulded Products, Accessory Products or Avlite Products found to be defective in material and workmanship in the relevant warranty period so long as the Warranty Conditions (set out below) are satisfied.
5. If any Telemetry Products or Avlite Products are fitted with a rechargeable battery, Avlite Systems warrants the battery will be free from defect for a period of one (1) year when used within original manufacturer's specifications and instructions.

Warranty Conditions

This Warranty is subject to the following conditions and limitations;

1. The warranty is applicable to lights manufactured from 1/1/2009.
2. The warranty is void and inapplicable if:
 - a. the product has been used or handled other than in accordance with the instructions in the owner's manual and any other information or instructions provided to the customer by Avlite;
 - b. the product has been deliberately abused, or misused, damaged by accident or neglect or in being transported; or
 - c. the defect is due to the product being repaired or tampered with by anyone other than Avlite or authorised Avlite repair personnel.
3. The customer must give Avlite Systems notice of any defect with the product within 30 days of the customer becoming aware of the defect.
4. Rechargeable batteries have a limited number of charge cycles and may eventually need to be replaced. Typical battery replacement period is 3-4 years. Long term exposure to high temperatures will shorten the battery life. Batteries used or stored in a manner inconsistent with the manufacturer's specifications and instructions shall not be covered by this warranty.



5. No modifications to the original specifications determined by Avlite shall be made without written approval of Avlite Systems.
6. Avlite lights can be fitted with 3rd party power supplies and accessories but are covered by the 3rd party warranty terms and conditions.
7. The product must be packed and returned to Avlite Systems by the customer at his or her sole expense. Avlite Systems will pay return freight of its choice. A returned product must be accompanied by a written description of the defect and a photocopy of the original purchase receipt. This receipt must clearly list model and serial number, the date of purchase, the name and address of the purchaser and authorised dealer and the price paid by the purchaser. On receipt of the product, Avlite Systems will assess the product and advise the customer as to whether the claimed defect is covered by this warranty.
8. Avlite Systems reserves the right to modify the design of any product without obligation to purchasers of previously manufactured products and to change the prices or specifications of any product without notice or obligation to any person.
9. Input voltage shall not exceed those recommended for the product.
10. Warranty does not cover damage caused by the incorrect replacement of battery in solar light models.
11. This warranty does not cover any damage or defect caused to any product as a result of water flooding or any other acts of nature.

Limitation of Liability

To the extent permitted by section 68A of the Trade Practices Act 1974 (Cth), the liability of Avlite Systems under this Warranty will be, at the option of Avlite Systems, limited to either the replacement or repair of any defective product covered by this Warranty.

Limited to Original Purchaser

This Warranty is for the sole benefit of the original purchaser of the covered product and shall not extend to any subsequent purchaser of the product.

Miscellaneous

Apart from the specific warranties provided under this warranty, all other express or implied warranties relating to the above product is hereby excluded to the fullest extent allowable under law. The warranty does not extend to any lost profits, loss of good will or any indirect, incidental or consequential costs or damages or losses incurred by the purchaser as a result of any defect with the covered product.

Warrantor

Avlite Systems has authorised distribution in many countries of the world. In each country, the authorised importing distributor has accepted the responsibility for warranty of products sold by distributor. Warranty service should normally be obtained from the importing distributor from whom you purchased your product. In the event of service required beyond the capability of the importer, Avlite Systems will fulfil the conditions of the warranty. Such product must be returned at the owner's expense to the Avlite Systems factory, together with a photocopy of the bill of sale for that product, a detailed description of the problem, and any information necessary for return shipment.

Other Avlite Products Available



Solar Aviation Lighting



Radio Controlled & PALC Systems (FCC Compliant)



Obstruction Lighting (LIOL A & LIOL B)



Airfield Markers & Accessories

Typical Applications

- Temporary & permanent airfield lighting
- Remote, emergency & defence airfield lighting
 - Barricade, hazard & perimeter lighting
 - Obstruction Lighting

For a complete list of product compliances including ICAO & FAA, please contact Avlite today



Area & Sign Lighting



Head Office

Avlite Systems
11 Industrial Drive
Somerville, Vic 3912
Australia

Tel: +61 (0)3 5977 6128
Fax: +61 (0)3 5977 6124

Email: info@avlite.com
Internet: www.avlite.com

A subsidiary of Sealite Pty Ltd www.sealite.com