

**OPERATOR'S
SPARE PARTS &
SERVICE MANUAL**



Type 'W' Vibrating Pokers and Drive Units

FAIRPORT
CONSTRUCTION EQUIPMENT LTD

Blagden Street
Sheffield
S2 5QS
ENGLAND
Tel: +44 (0) 114 276 7921
Fax: +44 (0) 114 272 0965
Email: sales@fairport.uk.com
Website: www.fairport.uk.com

'W' RANGE POKER MANUAL

CONTENTS

1.	INTRODUCTION.....	2
2.	TECHNICAL DATA.....	2
3.	SAFETY	3
3.1	FLEXIBLE CASING USED ON POKER VIBRATORS - COSHH REGULATIONS	4
3.1.1	Data Sheet On Flexible Casing.....	4
3.1.2	Fire.....	4
3.1.3	Storage Throttle Lever stop.....	4
3.1.4	Waste Disposal	4
3.2	SAFETY PICTOGRAMS USED ON THIS EQUIPMENT	6
4.	COMMISSIONING AND OPERATING INSTRUCTIONS	6
4.1	POKER DRIVE UNIT - PETROL OR DIESEL	6
4.2	POKER DRIVE UNIT - ELECTRIC.....	7
4.3	STARTING THE VIBRATING POKER	7
4.4	USER HINTS AND INSTRUCTIONS	8
5.	GENERAL MAINTENANCE	8
5.1	FLEXIBLE DRIVE SHAFT TYPE W525 - W536 - W545	8
5.2	FLEXIBLE DRIVE SHAFT TYPE W560	10
5.3	POKER HEAD TYPE W536, W545 & W560	10
5.4	POKER HEAD TYPE W525	11
5.5	PLUG-IN CONNECTOR.....	11
6.	WIRING DIAGRAMS.....	12
7.	PARTS LIST - POKER HEADS.....	13
8.	PARTS LIST - FLEXIBLE DRIVE SHAFT	14
9.	PARTS LIST - PLUG IN CONNECTORS (P.I.C.s).....	16
10.	PARTS LIST - PSD AND DSD DRIVE UNITS.....	17
11.	PARTS LIST - ESD & ECD ELECTRIC DRIVE UNITS	18
12.	PARTS LIST - EMD DRIVE UNIT	19
13.	WARRANTY CONDITIONS AND CLAIMS PROCEDURE.....	20
	CONDITIONS	20
	CLAIMS PROCEDURE.....	21
14.	REPAIRS AND ESTIMATES.....	21

Please note that the ECD type unit is obsolete as from serial number 62856 and is replaced by the EMD type unit.

1. INTRODUCTION

The 'W' range of internal concrete vibrators (pokers) is petrol engine or electric motor powered and drive is transmitted to the vibrating head using a flexible shaft. The 'W' system has four main components:

- a) A vibrating poker head
- b) A flexible drive shaft
- c) A quick action coupling
- d) A drive unit.

The quick action coupling is disconnected from the drive unit by hand. Spanners are required to remove the coupling from the flexible shaft and this may be carried out on site. Further dismantling should be carried out in a workshop.

Four models of poker are available, W525, W536, W545 and W566. The last two numbers of the model designation indicates the poker diameter in millimetres. The '5' indicates the nominal length of the flexible drive, which in this case, is the standard length of 5 metres. Special lengths are available to order.

Couplings are available that will screw on to the flexible drive and plug in to alternative makes of drive unit. The alternatives that are available are shown on the parts list in this manual.

This manual is concerned with the safe use and routine maintenance of this equipment. It is recommended that poker heads that require repair be returned to one of the Fairport depots at either Sheffield or Edenbridge.

2. TECHNICAL DATA

Drive Units - Petrol/Diesel

<u>Engine</u> <u>Make/Type</u>	<u>L</u> <u>mm</u>	<u>W</u> <u>mm</u>	<u>H</u> <u>mm</u>	<u>Wt</u> <u>kg</u>	<u>Net BHP</u> <u>@2800rpm</u>	<u>LwA</u> <u>DB (A)</u>
Honda GX160	410	510	535	26	4.0	98
Yanmar L40	410	510	535	42	3.4	96
Hatz 1B30	460	460	470	TBA	6.3	TBA
Petter AC1	520	480	550	70	5.2	102

LwA levels based on engine manufacturers' data.

Drive Units - Electric

	<u>ECD</u>	<u>EMD</u>	<u>ESD</u>
Electrical data	0.75kw, 115/230v, 12.6/6.3A, 1ph	0.75kw, 115/230v, 12.6/6.3A, 1ph	1.5kW, various voltages, see motor plate
Length:	360mm	365mm	360mm

Width:	245mm	245mm	360mm
Height:	380mm	315mm	350mm
Weight:	17.7 kg	17.0	23kg
LwA:	less than 85dB(A)	less than 85dB(A)	less than 85dB(A)
Switch insulation	IP66	IP66	IP65
Motor insulation	IP55	IP55	IP55

<u>Poker Sound Levels dB (A)</u>	<u>W525</u>	<u>W536</u>	<u>W545</u>
<u>W560</u>			

In concrete:

Operator position LpA:	67.8	75.0	75.6	79.4
Power level LwA:	80.0	87.5	88.4	94.4

In air:

Operator position LpA:	74.0	79.0	85.0	87.2
Power Level LwA:	86.6	90.8	98.0	99.2

Hand/arm vibration levels, m/sec² maximum axis:

In concrete:	4.0	5.0	7.0	5.5
In air:	4.0	5.0	7.0	5.5

Sound levels tested according to ISO 5349
Vibration levels tested according to ISO 3746

3. SAFETY

Never run petrol or diesel engines in trenches or confined spaces.

Never attempt to carry out maintenance with engine or motor running.

Never top up fuel tank whilst engine is running; don't smoke; wipe up spilt fuel.

Dispose of fuel contaminated wipes safely.

Always turn off fuel after use.

Always isolate electric motors after use.

Always use residual current devices with electric motors.

Always wear suitable protective clothing, i.e. safety helmet, footwear, ear defenders and gloves.

Ensure guards are always fixed in position when engines/motors are running.

Always comply with site safety regulations.

Do not attempt to carry out repairs to electric drive units unless you are a competent electrician.

3.1 FLEXIBLE CASING USED ON POKER VIBRATORS - COSHH REGULATIONS

This data sheet provides the information required on Section 6 of the Health and Safety at Works Act 1974 as amended by Schedule 3 of the consumer Protection Act 1987.

3.1.1 Data Sheet On Flexible Casing

The Polymeric compounds used on hose may contain materials that can migrate to the surface from whence they could be transferred to the skin during handling. This may cause skin irritation to persons who frequently handle hose. Persons who have to handle the hose frequently are advised to follow good hygienic practices e.g. wear gloves whenever practicable. Use barriers cream and wash hands after work before eating, drinking or smoking.

3.1.2 Fire

With a few exceptions the polymeric materials used by Dunlop Hose Limited are not easy to ignite in bulk. However when exposed to flame or to serious overheating they will decompose liberating noxious or toxic smoke or fumes. Fire precautions should recognise the hazards that may arise from indirect involvement in a fire as well as the inherent fire risk of the individual products.

Specialised advice on fire precautions is available from local Fire Authorities and from Health & Safety Executive.

3.1.3 Storage

Hose may deteriorate in appearance and physical properties during storage particularly if adverse storage conditions apply. BS3574 details the most suitable conditions for storage. In summary, hose should be stored in an unstressed darkened condition below 25° C and protected from moisture and air circulation. Exposure to atmosphere containing high concentration of ozone (eg. near discharge from electric motors) is to be particularly avoided. Hose should be stored away from direct heat and contact with strong oxidising agents should be avoided.

3.1.4 Waste Disposal

Hose should be disposed of by normal waste disposal procedures. Where

incineration is used the incinerator must be specifically designed to give complete combustion of the gases and fumes produced.

3.2 SAFETY PICTOGRAMS USED ON THIS EQUIPMENT



Wear Gloves



Wear ear protectors



Read the manual before using this equipment

4. COMMISSIONING AND OPERATING INSTRUCTIONS

The machine as delivered will generally be in two main assemblies:

- a) The drive unit
- b) The poker head complete with flexible shaft drive and coupling.

To assemble the flexible poker drive to the power unit, raise the latch knob on the coupling housing on the engine and insert the coupling attached to the end of the flexible drive. On releasing the knob the plunger should locate itself in the groove in the plug-in connector. When connecting to a petrol or diesel engine it may be necessary to rotate the engine crankshaft by means of the rope or handle starter at the same time applying pressure to the coupling in order to obtain engagement. Check the engagement by pulling on the coupling after releasing the latch knob. The coupling must never be inserted into or removed from the housing with the engine or electric motor running.

If the coupling is disconnected from the flexible shaft at any time, be sure to protect all exposed ends from possible damage or entry of foreign matter.

When transporting flexible poker shaft assemblies, it is essential that they are never coiled too tightly, likewise acute bends should be avoided when operating on site. The recommended method of storing these flexible shafts is on timber racks so that the shaft is kept straight and supported throughout its full length.

4.1 POKER DRIVE UNIT - PETROL OR DIESEL

Carefully read the engine manufacturer's instruction book before starting.

Check oil level.

Turn fuel tap on.

Put speed control lever to tick-over.

If engine is cold, close the choke (petrol engines only).

Turn engine switch to ON (1) position.

Pull the starter rope toggle lightly until resistance is felt, then pull briskly using quick short pull. Do not pull rope to its full extent or allow toggle to snap back against engine. Return it gently to avoid damage.

When engine is warm open choke.

Position engine speed control lever to give required engine speed (usually full speed, but see note below).

To stop engine, position the engine speed control to slow and turn the engine switch to off (0).

Turn the fuel valve to off.

NOTE: The governors of petrol and diesel engine drive units have been set at 2,750/2,850 rpm maximum. It is essential that the engine speed is not increased over 3,000 rpm as this will induce stress which may result in the failure of the poker head or flexible shaft and therefore invalidate any warranty. CHECK ENGINE SPEED.

4.2 POKER DRIVE UNIT - ELECTRIC

The electric motor supplied is a totally enclosed, fan-cooled type, operating at a continuous rated speed of 2,850 rpm. Check that the voltage, number of phases and frequency requirements of the motor being used are compatible with the supply.

When making electric connections, it is essential that the output shaft runs in an anti-clockwise direction when viewing the drive claw through the open end of the housing.

Always use a cable of sufficient cross section to avoid excessive voltage drop. This is the major cause of electrical problems and motor overloading with 110v supplies. If in doubt consult a qualified electrician.

4.3 STARTING THE VIBRATING POKER

With the coupling correctly inserted into the housing start the engine or switch on the electric motor. During cold weather it is advisable to run petrol or diesel engines for a few minutes before connecting the flexible drive.

If the poker head does not start vibrating when the drive unit is at full speed tap the nose cap on a hard surface. Avoid tapping the body of the poker head, as this has not been hardened.

4.4 USER HINTS AND INSTRUCTIONS

Use the largest poker that the job and reinforcement will allow.

Move the poker frequently. A little and often over an area is better than holding it in one place for a long time.

Make sure the whole area is covered.

Withdraw the poker slowly to ensure the hole is closed with adequately vibrated concrete.

When using a poker with timber formwork make sure the poker does not damage the formwork. Consider using a poker with a polyurethane nose cap – contact Fairport or your dealer.

When vibrating a layer of concrete, which has been poured onto a previously vibrated layer, ensure the poker penetrates the previous layer by about 100mm.

Do not try to vibrate concrete in layers greater than 300mm to 400mm.

Try to immerse the whole of the poker head in the concrete to provide some cooling.

Do not leave the poker running when it is not in concrete. This will prevent overheating of the bearings.

Avoid tight bends in the flexible drive shaft. Tight bends cause rapid wear of the flexible core.

Check on a regular basis (weekly) that all joints on the flexible drive are tight.

Do not allow the coupling end of the flexible drive to lie in wet conditions on the ground, as the entry of water to the bearings will cause rusting.

Do not stop the vibration whilst the poker is still in the concrete. It may prove difficult to remove and it will leave a void.

5. GENERAL MAINTENANCE

5.1 FLEXIBLE DRIVE SHAFT TYPE W525 - W536 - W545 (Refer also to Parts List)

The flexible drive shaft should be dismantled and re-charged with grease every 500

working hours. As it is extremely difficult to keep accurate records, we would suggest that the flexible poker drive be overhauled at set regular intervals. This will ensure trouble free operation. The recommended grade of grease is Castrol BM2 or an equivalent.

Do not attempt to carry out the lubrication of the flexible shaft drive under site conditions; this should always be carried out in a maintenance workshop.

When dismantling the flexible poker drive, first remove the plug-in connector (left hand thread). The complete plug-in connector assembly may then be pulled away from the flexible shaft.

Hold the bearing housing of the poker head assembly in a vice, then unscrew the poker housing, complete with nose cap, in a clockwise direction (left hand thread).

Next unscrew the flexible drive outer case coupling from the bearing housing in a clockwise direction (left hand thread).

Pull the outer casing away so as to expose the core coupling.

Hold the core coupling in a vice and unscrew the pendulum, complete with bearing and oil seal etc., in an anti-clockwise direction (right hand thread).

The inner flexible core can now be withdrawn from the outer casing.

Clean the flexible steel inner core and core couplings thoroughly with grease solvent.

Clean ends of outer casing with a cloth.

After thoroughly cleaning the complete flexible drive shaft, inspect the inner core for any excessive wear due to rubbing action between the core and outer casing spiral reinforcement; also for damaged and broken outer layer wires. If there is a permanent bend in the outer casing we advise fitting a replacement, as this is liable to cause damage to the inner core.

Regrease the first 12" - 18" (30 - 40cm) of the inner core with Castrol BM2 grease. Insert the greased inner core into the casing from the plug-in connector end. Continue greasing the inner core and at the same time insert it into the casing. Continue until the whole length of inner core has been greased.

As the inner core is pushed through the outer casing, some of the grease will naturally adhere to the inner walls of the casing. To ensure adequate lubrication, it is advisable to draw out the core for approximately 6ft (2 metres) from the other end, regrease as the core is inserted back into the casing.

It is essential during the regreasing operation to keep dirt and grit away from the component parts.

To re-assemble the flexible drive to the poker head, proceed as follows:

Renew the 'O' ring in the groove at the lower end of the external thread in the outer case coupling (poker head end).

Pull out the inner core for about 4" (10cm) and screw the core coupling (right hand thread) on to the exposed end of the pendulum, then screw the outer case coupling into the bearing housing in an anti-clockwise direction (left hand thread). During this operation, ensure not to damage the fine thread.

Before replacing the poker housing, wipe the pendulum with a clean dry cloth to remove any traces of grease or dirt. The interior of the poker housing and nose cap must be cleaned in a similar manner. Traces of grease on either of these components will upset the operation of the vibrating poker.

Renew the 'O' ring fitted between the poker housing and the bearing housing, also the one fitted to the nose cap. These rings must be in good condition to ensure a satisfactory seal between the various components.

When screwing on the plug-in connector to the other end of the flexible poker drive. Ensure that the keyway is fully engaged with the internal key of the main shaft.

5.2 FLEXIBLE DRIVE SHAFT TYPE W560 (Refer also to Parts List)

The frequency of re-greasing and the grade of lubricant recommended are as quoted in the previous section.

The operations for dismantling and cleaning are as described above except that this particular flexible drive shaft is fitted with an additional connector nut. This component has to be unscrewed from the bearing housing in an anti-clockwise direction (right hand thread) prior to removal of the outer case coupling.

5.3 POKER HEAD TYPE W536, W545 & W560 (Refer also to Parts List)

When dismantling a poker head, first remove the flexible drive shaft as described in section 5.1 and 5.2.

The pendulum can be removed by supporting the bearing housing and applying pressure to the threaded end of the pendulum.

NOTE: It is important to ensure that the screw thread is not damaged during this operation.

The bearing, oil seal and oil seal carrier can be easily removed from the bearing housing.

After cleaning all the poker head parts thoroughly in grease solvent, inspect the components for possible wear or damage.

The double row self-aligning bearing that supports the pendulum is to a specification that limits the diametral clearance between the inner and outer tracks. If a standard bearing were used as a replacement, the efficiency of the poker would be impaired.

Do not forget to replace the Shake proof washer.

We recommend the replacement of the bearing, oil seal and 'O' rings whenever a poker is dismantled.

When re-assembling the poker head, pack the double row self-aligning bearing with Castrol BM2, or equivalent.

Before replacing the poker housing, ensure that both the pendulum and the interior of the housing, including the nose cap, are clean and free from all traces of grease, as the presence of grease will severely affect the efficiency of the poker.

Do not forget to fit new 'O' rings to ensure that all joints are watertight.

5.4 POKER HEAD TYPE W525 (Refer also to Parts List)

The procedure for dismantling the 525 type poker head is similar to that described for larger models. However a separate oil seal housing is not fitted to type 525. The oil seal fits directly into the bearing housing.

In addition, a plain and shake proof washer is fitted between the self-aligning bearing and the shoulder formed in the bearing housing. When re-assembling the poker head, it is essential that the washer be positioned correctly; failure to do so may result in it restricting the angular movement of the pendulum.

As mentioned in the various sections it is essential to thoroughly clean all the parts prior to re-assembly and grease the bearings with the recommended lubricant.

5.5 PLUG-IN CONNECTOR (Refer also to Parts List)

Should it be necessary to dismantle the coupling, proceed as follows: -

Unscrew main shaft head and remove internal circlip.

Press out the main shaft complete with bearings etc., by means of an arbour or fly press. When carrying out this operation support the large diameter of the housing and apply pressure to the small end of the shaft.

Next remove the circlip and withdraw the key retaining collar, the key itself can now be withdrawn from its locating keyway.

The bearings and spacer can now be pressed off the main shaft.

Check the condition of the two ball bearings, and replace if necessary.

Reassembly is generally the reverse of the above procedure.

After fitting the ball bearing and spacer the driving key can be inserted in the keyway and the key-retaining collar replaced to hold the key in position.

Fit the circlip to retain the collar.

Fill the space between the two bearings with Castrol BM2 grease.

Press in the bearing sub-assembly into the housing until the inner bearing is in contact with its locating shoulder.

Refit internal circlip and screw on main shaft head.

When screwing on the plug-in connector to the flexible drive shaft, be sure that the core coupling keyway is fully engaged with the internal key of the main shaft.

6. WIRING DIAGRAMS

The electric motors used on ECD and EMD units are dual voltage. Check wiring as below.

If a wiring diagram is required for an ESD type please contact Fairport Construction Equipment Ltd quoting voltage, kilowatts and serial number.

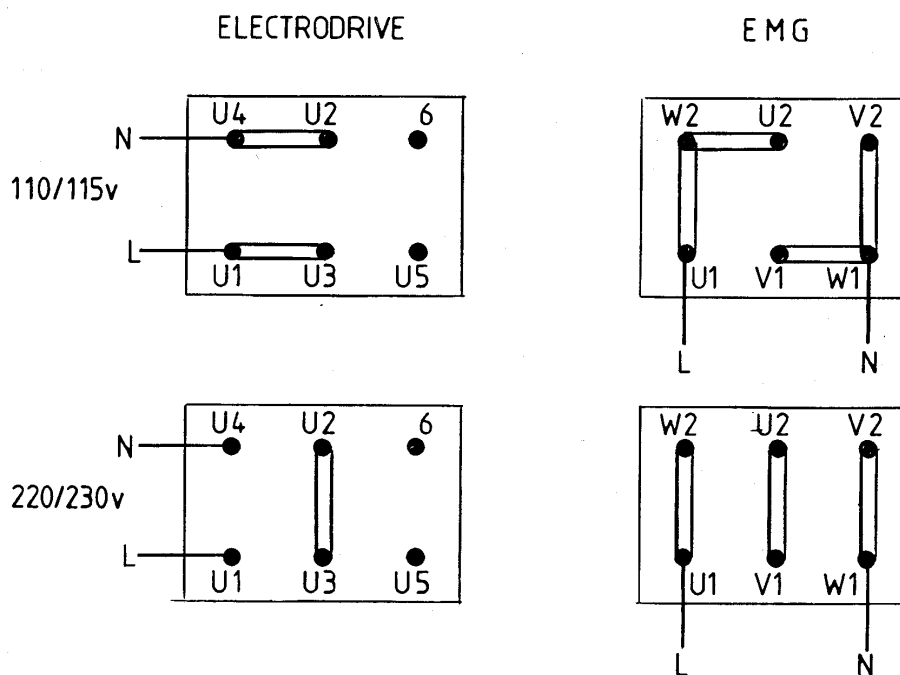

7. PARTS LIST - POKER HEADS

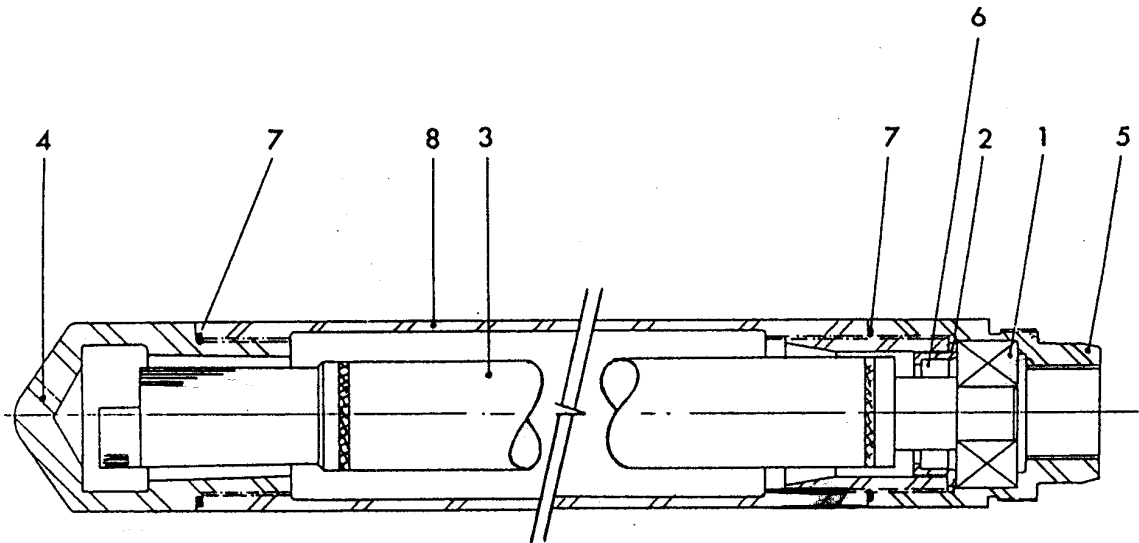

<u>Ref. No</u>	<u>Description</u>	<u>Model and Part Number</u>			
		<u>W525</u>	<u>W536</u>	<u>W545</u>	<u>W560</u>
1	Bearing	W81065	W81062	W81063	W81064
2	Oil Seal Housing		W60234	W60247	W60210
3	Pendulum	W60261	W60228	W60241	W60201
4	Nose Cap	W60263	W60233	W60246	W60209
	'Rubber' nose cap	n/a	W60815	W60786	W60785
5	Bearing Housing	W60264	W60235	W60248	W60211
6	Oil Seal	W81232	W81233	W81234	W81209
7	'O' Ring	W81132	W81107	W81134	W81135
8	Housing	W60262	W60229	W60242	W60205
	Poker Head Ass'y	W60260	W60227	W60240	W60200

Note: W560 Poker illustrated

8. PARTS LIST - FLEXIBLE DRIVE SHAFT

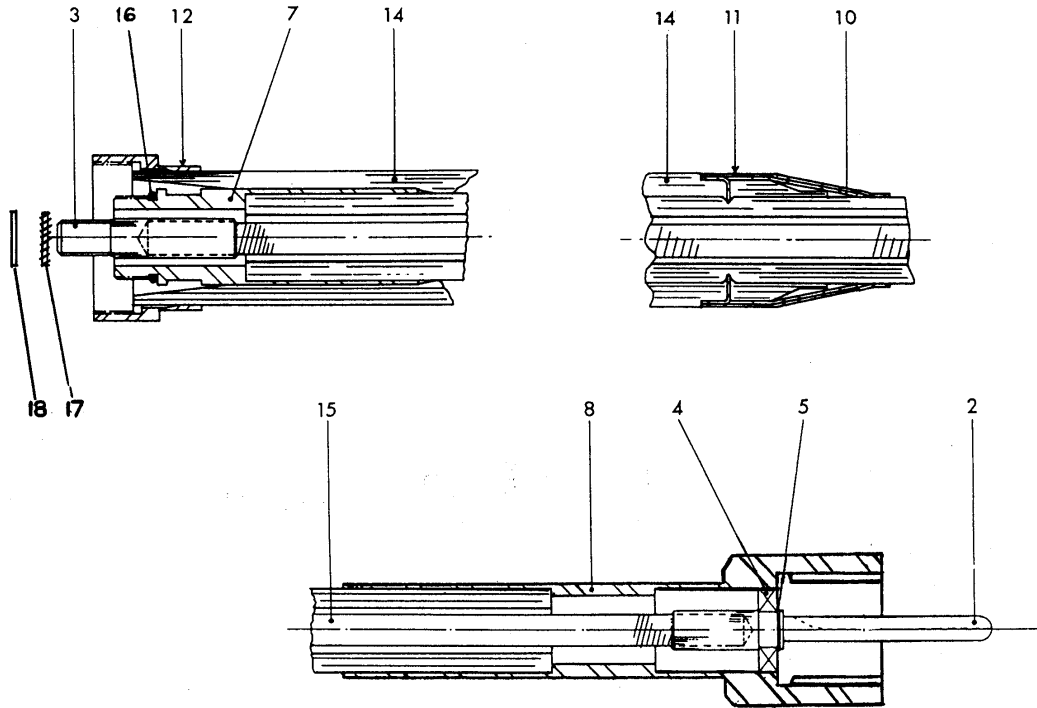

Ref. No	Description	Model and Part Number			
		W525	W536	W545	W560
1	Complete Drive, 5mtr.long O/Casing complete, 5mtr long	W60791	W60790	W60790	60792
2	Keyway Core Cplg	W60844	W60849	W60849	W60852
3	Threaded Core Cplg	W62010	W62016	W62016	W62016
4	Bearing	W62011	W62017	W62017	W62021
5	Circlip - External	none	W81070	W81070	W81070
7	Casing Coupling - Poker End	none	W81314	W81314	W81314
8	Casing Coupling - Motor End	W62012	W62018	W62018	W62018
9	Spiral Protector	W62100	W62093	W62093	W62093
10	Half Clamps (2 off)	W62014	W62020	W62020	W62020
11	Taper Sleeve	n/a	n/a	n/a	W62022
12	Connector Nut	n/a	n/a	n/a	W62023
14	Reinforcement Sleeve	n/a	n/a	n/a	W62024
15	Inner Core complete 5mtr	n/a	n/a	n/a	W60040
16	'O' Ring	W60842	W60846	W60846	W60850
17	Shake proof Washer 425/8	W81132	W81107	W81107	W81107
18	Plain Washer	439/6	425/6	425/6	
		418/6	419/6	419/6	418/12

Note: W560 Flexible Drive illustrated.

9. PARTS LIST - PLUG IN CONNECTORS (P.I.C.s)

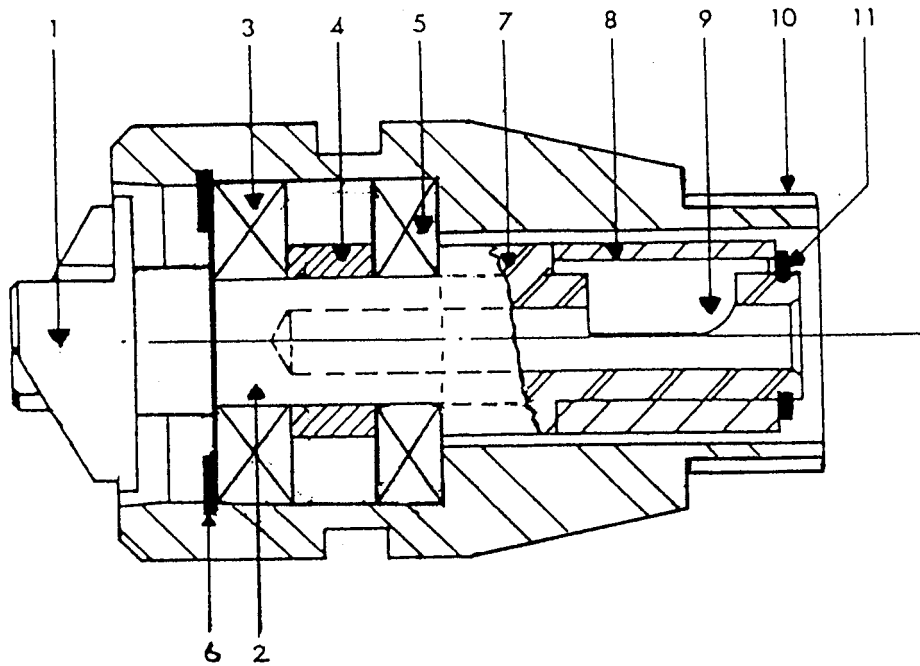

Warsop plug-in connector illustrated.

<u>Description</u>	<u>Warsop</u>	<u>Errut</u>	<u>Dynapac</u>	<u>Wacker</u>	<u>Fyne</u>	<u>Metrix</u>	<u>CEL</u>
P.I.C. No	W60803	W60802	W60801	W60813	92961	92844	93036
1 Mainshaft Head	W60358	W60437	W60453	W60453	W50646	W50637	W60453
2 Main Shaft	W60746	W60438	W60454	W60454	W60462	W60746	W60454
3 Bearing	W81066	W81066	W81066	W81066	W81006	W81060	W81066
4 Spacer	W60385	W60385	W60385	W60385	W60466	W51056	W60385
5 Bearing	W81066	W81066	W81066	W81066	W81006	W81060	W81066
6 Int. Circlip	W81256	W81256	W81256	W81256	n/a	W81253	W81256
7 Spindle Adaptor	n/a	W60461	W60461	W60461	n/a	n/a	W60461
8 Collar	W60747	W60012	W60012	W60012	W60870	W60747	W60012
9 Drive Key	W60011	W60011	W60011	W60011	W60033	W60011	W60011
10 Housing	W60798	W60799	W60800	W60812	W60866	W51055	W60800
11 Ext.Circlip	W81312	W81312	W81312	W81312	W81400	W81312	W81312
Caphead screw					450/6/8		
Tolerance ring					W80616		
Spacer (fits behind dog)							W60875

10. PARTS LIST - PSD AND DSD DRIVE UNITS

Description: Warsop	Petrol PSD	Diesel DSD
Dog (5/8" UNF)	W60163	W60163
Spacer (5/8")	W60819	W60819
Dog (3/4" key'd)	W60434	W60434
Grub Screw	462/6/12k	462/6/12k
Spacer (3/4")	W60804	W60804
Engine Flange	W60411	W60411
Plunger Assy	W60020	W60020
Flange Fixing Screw	408/5/16	407/5/16 (Petter) 437/8/25 (Yanmar)
Flange Fixing Washer	439/8	439/8
Metal Rubber Base	W60777	W13037
Birdcage	W60818	W11224
Birdcage Fixing Screw	437/8/16	437/8/16
" " Washer	439/8	439/8
Engine Fixing Stud	519/8/45	519/8/45
" " Nut	440/8	440/8
" " Washer	439/8	439/8

Alternative for Dynapac Type Fitting

Engine Flange	W60479	W60479
Dog (5/8" UNF)	W60153	W60153
Spacer (5/8")	W60445	W60445
Dog (3/4" key'd)	W60434	W60434
Spacer (3/4")	W60821	W60821

Engine Options 5/8 UNF Shaft 3/4 Key'd Shaft

Robin EY20	W81798	W81776
Honda GX160	W81732	W81731
Briggs & Stratton	W81785	
Petter AC1	W81855	
Yanmar L40		W81843

Additional Items for Honda Engines:

Throttle Lever stop (GX160)	W51785
M6 Star Washer (between stop and bracket)	439/6
M6 Hex Screw	437/6/16
M6 Plain Washer	418/6
M6 Nyloc Nut	480/6

11. PARTS LIST - ESD & ECD ELECTRIC DRIVE UNITS

Model	<u>ESD</u>	<u>ESD</u>	<u>ECD</u>
Electrical data: volts	380-415	110-115/220-230	110/220
kW	1.5	1.5	0.75
amps	5.5-5.2/3.2-3.0	27.2/13.6	12.8/6.4
phase	3	1	1
Hz	50	50	50
Dog	W60820(1)	W60820(1)	W60150
Metal/Rubber Base	W60881	W60881	Metal Base W60693
Frame Assembly	W60773	W60773	W60793
Handle			W19278
Handle Grip			W80148
Handle Fixing Screw			437/12/25
Washer			439/12
Motor/Flange Adaptor	W60780	W60780	
Fixing for Frame:Set Screw	437/8/12	437/8/12	
Washer	439/8	439/8	
Adaptor to Motor Fixing	455/8/16	455/8/16	
Motor	W81946	W82104	W60735
Fixing for Motor: Screw	437/8/20	437/8/20	469/8/25
Washer	439/8	439/8	418/8
Nut			480/8
Switch/Starter	W60752	W17271 (110v)	W60686
Switch/Starter		W17272 (230v)	
For Fixing Switch: Screw	449/5/16	449/5/16	455/5/25
or Starter Nut	480/5	480/5	480/5
Conduit Nut	531/20	531/20	
Cable Gland	W17276	W17276	W13408
110v Plug		W19724	W19704
230v Plug		W19706	W19706
380/415v Plug	W81957		
Flange	W60687	W60687	W60687
Plunger Assy	W60020	W60020	W60020
Fixing for Flange:Set Screw	437/6/25	437/6/25	437/6/25
Washer	439/6	439/6	439/6
Cable, state length required	W80095	W82101	W60334

Alternative Dynapac Type Fittings

Flange	W60741	W60741	W60153
Dog	W60820(2)	W60820(2)	W60153
Spacer			W60851

(1) Distance between back of Dog and shaft shoulder is set at 8mm

(2) " " " " " " " " " " " " " " 15mm

12. PARTS LIST - EMD DRIVE UNIT

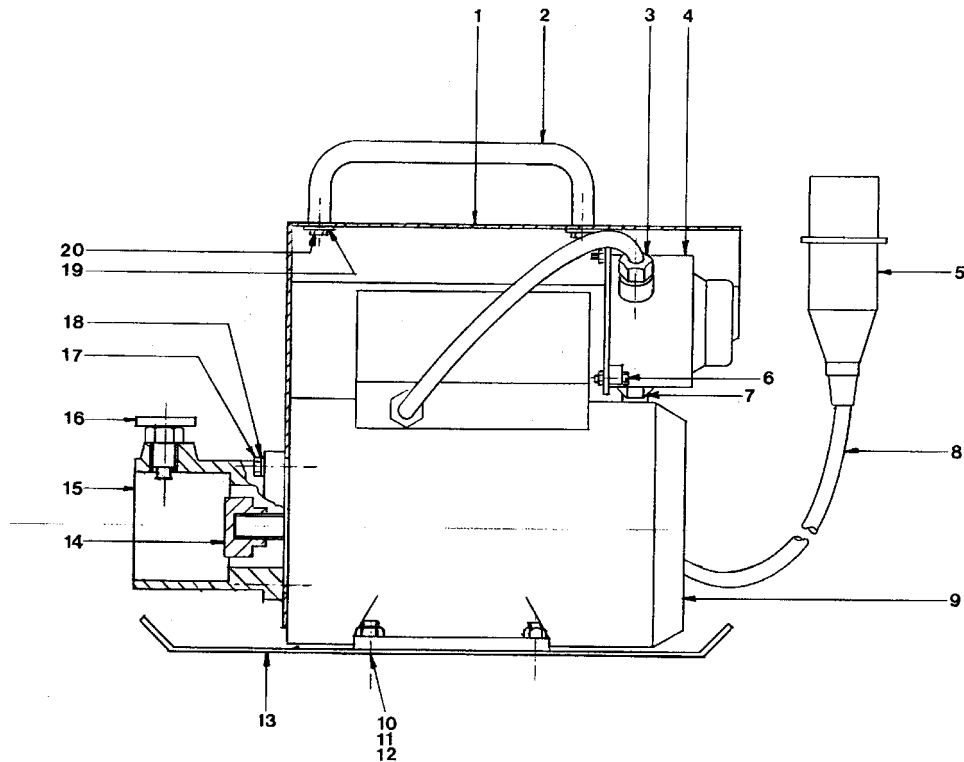

<u>Item</u>	<u>Part No</u>	<u>Description</u>
1	W60879	Motor cover
2	W80617	Handle
3	W13408	Cable gland - output from switch
4	W60686	Switch
5	W19704	Plug, 110v
5	W19706	Plug, 230v
6	W455/5/25	M5 X 25 SKT HD CAP Screw
--	W439/5	M5 SHAKE PROOF WASHER
--	P100-0005-01	M5 WASHER
7	W82179	Cable gland - supply
8	W60334	Cable - state length required
9	W82178	Motor - state voltage required
10	469/8/30	M8 X 30 csk screw
11	480/8	M8 Nyloc nut
12	420/8	M8 washer
13	W60693	Base
14	W60150	Drive dog - Warsop
15	W60687	Flange - Warsop
16	W60020	Plunger
17	W437/6/25	M6 hex set screw
18	W439/6	M6 Shake proof washer
19	W439/6	M6 Shake proof washer
20	W4376/12	M6 hex set screw

Alternative Dynapac Type Fittings

W60741	Flange
W60153	Drive dog
W60851	Spacer - fits behind dog

13. WARRANTY CONDITIONS AND CLAIMS PROCEDURE

All products supplied by Fairport Construction Equipment Ltd (hereafter referred to as FCE) are warranted to be free of defects due to faulty materials or workmanship for a period of 12 months from the date of original despatch from FCE or as specified below:

Hydraulic hoses and hydraulic couplings – 3 months.

Hydraulic accumulators – 6 months.

Flexible drives – 6 months.

All spare parts used in repairs carried out by FCE or an authorised dealer or repairer – 3 months.

If the goods have been purchased through a stockist the above warranty periods also apply from receipt of the goods by the user of the equipment up to a total of a further 6 months from date of despatch from FCE whichever is earlier.

Filter elements, gauges and oils are specifically excluded from this warranty.

FCE shall at their option repair or replace during normal working hours goods accepted as faulty free of charge to the user.

For proprietary items such as engines, the original manufacturer's warranty and conditions shall apply.

CONDITIONS

The goods shall be returned at the purchaser's expense to FCE or to a destination FCE may reasonably direct. Carriage costs will be refunded if warranty is accepted.

Warranty claims will not be considered where there is evidence that failure has been caused by carelessness, improper use, negligence, inadequate servicing, incorrect engine speeds, fair wear and tear or non-compliance with instructions issued by the manufacturer.

To the extent permitted by law, the liability of FCE under this section is confined only to providing a remedy for defective goods and does not extend to any consequential loss, loss of profit, injury or damage suffered.

Warranty will not be accepted on dismantled goods unless dismantling was carried out with the written permission of FCE.

No claim shall be considered if other than genuine parts supplied by FCE have been used.

Products are only covered by this warranty in the country to where they were supplied by FCE.

Warranty on products applies only to the original user of the equipment.

This warranty shall not apply if the serial number or other identifying numbers or marks applied by FCE have been removed, defaced or are otherwise illegible.

CLAIMS PROCEDURE

Check that the goods are still under warranty before returning them to FCE (see above for warranty periods).

Return the goods to FCE with an order number for the work to proceed. If warranty is accepted no charge will be made. If warranty is not accepted a quotation will be given for the repair and the conditions under the section headed REPAIRS AND ESTIMATES will apply.

In the customer's interest, goods must be accompanied by documentation detailing the nature of the fault or its symptoms. Phrases such as 'Faulty' are unacceptable and will result in delays and possible charges to defray costs incurred in identifying the fault.

In the case of hydraulic breakers and power packs, both the breaker and the pack should be returned

14. REPAIRS AND ESTIMATES

When returning a machine, or an assembly for repair, always include an Advice Note quoting model and serial number of the machine.

An official order must also be forwarded to FCE giving detailed instructions. No repair work can be carried out unless covered by an official order.

An estimate will be submitted before proceeding with any repair. To partly cover the cost in dismantling, cleaning and inspection, a small charge will be made, this however will be waived upon receipt of your official instructions to proceed with the repair.

In the event of the estimate not being accepted, a further charge will be made to defray the rebuilding of the machine.

Estimates must be treated as approximate only as it may be found necessary to use additional parts on further examination.

EC Declaration of Conformity

We Fairport Construction Equipment Limited

Blagden Street
Sheffield
S2 5QS

Declare that the product

“W” Type Poker & Drive Units
Manufactured from 1 Sept 2004

conforms to the following Directives:

89/336/EEC, 89/392/EEC, 91/368/EEC, 2000/14/EC

uses the following standards:

BS EN 292-1, BS EN 292-2, BS EN 294

conforms to the following Statutory Instruments

The Supply of Machinery (Safety) Regulations 1992 & amendments

Complies with the relevant essential health and safety
requirements of the Machinery Directive

Technical Construction File no **P.D.U.**



Technical Manager

Signature	Position
R.J.Castle I.Eng M.I.Mech.E.	12/12/2005
Signed by	Date Technical