

**Instruction 51-1025
4-21-06**

Copyright © 1995, 1996,
2002, 2005, 2006
by S&S Cycle, Inc.
All rights reserved.
Printed in the U.S.A.

S&S® Cycle, Inc.

235 Causeway Blvd.
La Crosse, Wisconsin 54603
Phone: 608-627-1497 • Fax: 608-627-1488
Technical Service Phone: 608-627-TECH (8324)
Technical Service Email: sstech@sscycle.com
Website: www.sscycle.com



Because every industry has a leader

Installation Instructions: S&S® Connecting Rods

DISCLAIMER:

S&S parts are designed for high performance, off road, racing applications and are intended for the very experienced rider only. The installation of S&S parts may void or adversely effect your factory warranty. In addition such installation and use may violate certain federal, state, and local laws, rules and ordinances as well as other laws when used on motor vehicles used on public highways, especially in states where pollution laws may apply. Always check federal, state, and local laws before modifying your motorcycle. It is the sole and exclusive responsibility of the user to determine the suitability of the product for his or her use, and the user shall assume all legal, personal injury risk and liability and all other obligations, duties, and risks associated therewith.

The words Harley®, Harley-Davidson®, H-D®, Sportster®, Evolution®, and all H-D part numbers and model designations are used in reference only. S&S Cycle is not associated with Harley-Davidson, Inc.

SAFE INSTALLATION AND OPERATION RULES:

Before installing your new S&S part it is your responsibility to read and follow the installation and maintenance procedures in these instructions and follow the basic rules below for your personal safety.

- Gasoline is extremely flammable and explosive under certain conditions and toxic when inhaled. Do not smoke. Perform installation in a well ventilated area away from open flames or sparks.
- If motorcycle has been running, wait until engine and exhaust pipes have cooled down to avoid getting burned before performing any installation steps.
- Before performing any installation steps disconnect battery to eliminate potential sparks and inadvertent engagement of starter while working on electrical components.
- Read instructions thoroughly and carefully so all procedures are completely understood before performing any installation steps. Contact S&S with any questions you may have if any steps are unclear or any abnormalities occur during installation or operation of motorcycle with a S&S part on it.
- Consult an appropriate service manual for your motorcycle for correct disassembly and reassembly procedures for any parts that need to be removed to facilitate installation.
- Use good judgement when performing installation and operating motorcycle. Good judgement begins with a clear head. Don't let alcohol, drugs or fatigue impair your judgement. Start installation when you are fresh.
- Be sure all federal, state and local laws are obeyed with the installation.
- For optimum performance and safety and to minimize potential damage to carb or other components, use all mounting hardware that is provided and follow all installation instructions.
- Motorcycle exhaust fumes are toxic and poisonous and must not be inhaled. Run motorcycle in a well ventilated area where fumes can dissipate.

IMPORTANT NOTICE:

Statements in this instruction sheet preceded by the following words are of special significance.



WARNING

Means there is the possibility of injury to yourself or others.



CAUTION

Means there is the possibility of damage to the part or motorcycle.

NOTE

Other information of particular importance has been placed in italic type.

S&S recommends you take special notice of these items.

WARRANTY:

All S&S parts are guaranteed to the original purchaser to be free of manufacturing defects in materials and workmanship for a period of twelve (12) months from the date of purchase. Merchandise that fails to conform to these conditions will be repaired or replaced at S&S's option if the parts are returned to us by the purchaser within the 12 month warranty period or within 10 days thereafter.

In the event warranty service is required, the original purchaser must call or write S&S immediately with the problem. Some problems can be rectified by a telephone call and need no further course of action.

A part that is suspect of being defective must not be replaced by a Dealer without prior authorization from S&S. If it is deemed necessary for S&S to make an evaluation to determine whether the part was defective, a return authorization number must be obtained from S&S. The parts must be packaged properly so as to not cause further damage and be returned prepaid to S&S with a copy of the original invoice of purchase and a detailed letter outlining the nature of the problem, how the part was used and the circumstances at the time of failure. If after an evaluation has been made by S&S and the part was found to be defective, repair, replacement or refund will be granted.

ADDITIONAL WARRANTY PROVISIONS:

- (1) S&S shall have no obligation in the event an S&S part is modified by any other person or organization.
- (2) S&S shall have no obligation if an S&S part becomes defective in whole or in part as a result of improper installation, improper maintenance, improper use, abnormal operation, or any other misuse or mistreatment of the S&S part.
- (3) S&S shall not be liable for any consequential or incidental damages resulting from the failure of an S&S part, the breach of any warranties, the failure to deliver, delay in delivery, delivery in non-conforming condition, or for any other breach of contract or duty between S&S and a customer.
- (4) S&S parts are designed exclusively for use in Harley-Davidson® and other American v-twin motorcycles. S&S shall have no warranty or liability obligation if an S&S part is used in any other application.

S&S® connecting rods are stronger than stock and most other types of rods because:

1. S&S rods have wider I-beams, heavier radiuses in critical areas, and extra gusseting.
2. S&S heavy duty and SUPREME 34-7900 rods are forged from 4140 chrome moly steel. All other SUPREME rods are forged from 4130EQ chrome moly steel.
3. S&S rods are heat treated to harder specifications.
4. S&S rods are shot peened.

IMPORTANT NOTES

- *S&S SUPREME rods require additional clearancing in all stock flywheel assemblies, and stock cases when most stroker kits are installed. It is the responsibility of the motor builder to check for any interference in all applications.*
- *Whenever clearancing is performed during any installation checks, follow recommended procedures only. Remove material only from specified areas.*
- *Thoroughly inspect, debur and clean all parts before final assembly. Blow air through oil passageways to check for blockages.*
- *Read manufacturer's instruction label before using solvents or degreasers when cleaning and assembling parts.*
- *Any modification performed to S&S rods other than those specified in these instructions voids any and all S&S warranties.*

⚠ CAUTION

Failure to follow recommended clearancing procedures and to use recommended clearances may cause damage to rods and/or other engine components.

⚠ WARNING

- **Unwarranted connecting rod clearancing may weaken a connecting rod possibly causing it to break. A broken connecting rod may cause the engine to stop suddenly without warning during operation possibly causing loss of control of motorcycle and personal injury to you or others.**
- **Some solvents, degreasers, and other chemicals are toxic and/or harmful to skin and eyes. Many items are flammable and present a fire hazard. Read manufacturer's instruction label for proper use. Use in well ventilated area and wear protective clothing when using them to avoid personal injury.**
- **Compressed air and particles dislodged by compressed air are harmful to eyes and body. Wear protective goggles when using compressed air and always direct air stream away from body parts such as hands and eyes. Never direct compressed air toward other people.**

Flywheel Balance

All S&S rods, because of their beefier construction, weigh more than comparable stock types. Therefore, it is recommended to check and rebalance flywheels when replacing other rods with S&S types.

Flywheel and Crankcase Clearancing

Due to increased front to rear I-beam width, crankpin end bulk, and gusseting of S&S rods, additional rod to flywheel and rod to crankcase clearancing will be required. Prior to flywheel rebalancing and final assembly, each flywheel must be mocked up with mainshaft and rods to check clearances. Places to note for contact are:

1. Female rod crankpin end to mainshaft nuts - .030" minimum clearance recommended.
 - A. Install sprocket shaft and crankpin in driveside flywheel. Snug nuts only. Do not torque to final specs.
 - B. Slide connecting rods and bearings over crankpin.
 - C. Rotate rods on crankpin, and observe clearance between rod and sprocket shaft nut.
 - D. If additional clearance is needed, remove material from sprocket shaft nut. Do not remove material from connecting rod.
 - E. Repeat procedure for camside flywheel and pinion shaft.
2. Female rod crankpin end to inner flywheel rim - .060" clearance recommended.
 - A. While checking female rod to mainshaft clearance, observe clearance between crankpin end of female rod and rim of both flywheels.
 - B. If additional clearance is required, remove material from flywheel at point of contact. Do not remove material from connecting rod.
3. Wristpin end of both female and male rods to flywheel edge - .060" minimum clearance recommended.
 - A. While checking female rod to mainshaft clearance, observe clearance between wristpin end of both rods and rim of both flywheels.
 - B. If additional clearance is required, remove material from flywheel at point of contact. Do not remove material from connecting rod.
4. Wristpin end to crankcase and cylinder - .060" is recommended in these areas.
 - A. With the camside flywheel and rods mocked up, install the assembly in the right crankcase half with pistons (less rings) and cylinders in place.
 - B. Rotate flywheel through one full revolution and check for rod to crankcase and cylinder spigot contact on both the front and rear of each cylinder.
 - C. File or grind crankcase or cylinder spigot as needed to achieve .060" clearance. Do not remove more material than needed.
 - D. Repeat for left crankcase half.

***NOTE:** Whenever clearancing is performed in any of these areas, do not remove any material from the connecting rods as clearancing on the rods may unnecessarily weaken them. Make adjustments to the point of contact on the mainshaft nut, flywheel rim, crankcase, cylinder spigot, etc.*

⚠ CAUTION

Connecting rods weakened by clearancing may fail causing serious engine damage.

Rod Side Play - Recommended rod side play is .015" to .035". If on assembly, side play is found to be less than .015", surface grind equal amounts off thrust faces on both sides of female rod. The recommended bearing cage width is .008" to .020" less than the female rod width. This must be checked if female rod has been narrowed.

Rod to Rod Clearance - S&S® rods have been machined to fit stroker flywheels up to and including 5" stroke without additional rod to rod clearance. If a longer stroke is to be used, this clearance must be checked and increased as necessary - .060" clearance is recommended and must be removed from the point of contact on the female rod. Remove only enough material to obtain recommended clearance. Smooth blend all clearance contours to avoid stress risers.

Roller Bearing Clearance - S&S rods for street applications have been honed to .001-.0012" running clearance. These rods require a new engine break-in period of at least 2000 miles.

NOTE: If connecting rods are to be used in a racing application where proper engine break-in is not possible, rod bearing races must be honed to provide a minimum of .0005" additional roller bearing clearance. S&S can supply rod sets with racing clearance on request at no additional charge.

SPECIFICATIONS AND RECOMMENDATIONS

Centerline Measurement - All S&S rod sets except 34-7800 and 34-7900 measure 7.440" from wristpin centerline to crankpin centerline. This dimension is the same as that of stock big twin rods from 1974 to present and stock Harley-Davidson® Ironhead Sportster® model rods from 1957 to 1985. This is .030" less than stock 1936 to 1973 big twin rods. S&S big twin rods can be used in applications replacing earlier, longer stock rods with the most noticeable effect being a drop in compression of about 1/8 to 1/2 point. Piston to piston and piston to flywheel clearances should be checked.

Rod set 34-7800 measures 6.926" from centerline to centerline. These rods are the same length as stock 1983 XR-1000® and 1986 and later Sportster® model rods. Rod set 34-7900 measures 7.113" from centerline to centerline and are a special length designed exclusively for S&S four cam Sidewinder®/stroker applications.

Wristpin Bushings - Connecting rods for Evolution® engines are sized for .792" diameter wrist pins. Connecting rods for pre-1984 engines are sized for .791" diameter wrist pins. Refer to **Chart 1** for part numbers, applications, and wrist pin diameters. When the correct style wristpin is used a running clearance is .001".

NOTE: If connecting rods fit for Evolution® wristpins are used with pre-1984 style wristpins, running clearance will be .002". Our experience has been that this amount of clearance will not cause problems, however correct clearance should provide better engine life and less possibility of noise.

S&S racing connecting rods utilize a 0.892" diameter wristpin. Refer to **Chart 1** for applications and part numbers. To alter a bushed S&S rod set to be used with S&S racing pistons which are equipped with a 0.892" diameter wristpins, the wristpin bushing must be pressed out, and a 3/32" diameter hole drilled on each side of the I-beam into the pin boss as close to parallel with the I-beam as possible. **See Figure 1.** After these holes are drilled, the wristpin hole of each rod must be honed to provide 0.001" running clearance.

Part #	Application	Rod Length	Wrist Pin Diameter	Bearing Cage Type
34-7000	1941-'81 bt	7.440"	.791"	Alloy
34-7003	1936-'52 61" bt	7.440"	.791"	Iron
34-7004	1941-'81 bt	7.440"	.791"	Iron
34-7010	1981-'84 bt	7.440"	.791"	Alloy
34-7011	1981-'84 bt	7.440"	.791"	Iron
34-7012	1984-Up bt	7.440"	.792"	Alloy
34-7013	1984-Up bt	7.440"	.792"	Iron
34-7200	1941-'81 bt	7.440"	.791"	Alloy
34-7203	1941-'81 bt	7.440"	.892"	Iron
34-7206	1941-'81 bt	7.440"	.791"	Iron
34-7210	1981-'84 bt	7.440"	.791"	Alloy
34-7211	1981-Up bt	7.440"	.892"	Iron
34-7212	1981-'84 bt	7.440"	.791"	Iron
34-7213	1984-Up bt	7.440"	.792"	Alloy
34-7214	1984-Up bt	7.440"	.792"	Iron
34-7500	1957-'81 xl	7.440"	.791"	Alloy
34-7510	1981-'85 xl	7.440"	.791"	Alloy
34-7700	1957-'81 xl BB	7.440"	.791"	Alloy
34-7703	1957-'81 xl BB	7.440"	.892"	Alloy
34-7710	1957-'81 xl SB	7.440"	.791"	Alloy
34-7720	1981-'85 xl BB	7.440"	.791"	Alloy
34-7721	1981-'85 xl BB	7.440"	.892"	Alloy
34-7722	1986-Up BB	7.440"	.792"	Alloy
34-7730	1981-'85 xl SB	7.440"	.791"	Alloy
34-7800	1986-Up xl	6.926'	.792"	Alloy
34-7900	1986-Up xl (Spec.)	7.113"	.792"	Alloy
34-7903	1984-Up bt (Spec.)	7.113"	.792"	Alloy

Chart 1

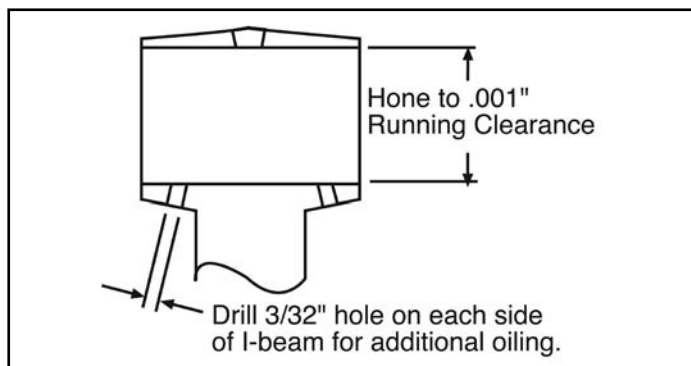

Figure 1

NOTE: S&S® offers connecting rod sets which are pre-fit to .892" diameter wrist pins. S&S also offers .001" and .002" oversize replacement wristpins for this application. See S&S catalog for part numbers.

S&S SUPREME Rods for Harley-Davidson® Sportster® models- These rods have wristpin ends machined to the same width as big twin rods (1.073") for 3-5/16" or larger bore sizes where more wristpin support is desired.

NOTE: In applications where less than a 3-5/16" bore is used, the width of the wristpin end is machined to .946". See the S&S catalog for part numbers.

CAUTION

Supreme rods with wristpin ends machined to 1.073" width must not be used in applications where bore size is less than 3-5/16" as contact with piston pins boss may result.

Polishing - All S&S rods are shot peened to increase fatigue resistance. Grinding and polishing the surfaces reduces this effect and is not recommended.

NOTE: S&S voids its guarantee if any S&S connecting rods are ground, polished or modified in any way.

Crankpin Nuts - All S&S big twin crankpins manufactured after May 1, 1990 are machined for late 1981 and later style crankpin nuts. The increased number of threads per inch (1"-20) and the larger nut surface area provide a stronger crankpin/nut assembly. Early style stock flywheels may require additional nut and socket clearance.

NOTE: When this combination is used in some early S&S flywheels, additional crankpin nut socket to flywheel clearance may be required. In these instances, S&S recommends removing the required material from the flywheels before balancing.

Torque Specifications - Use green grade Loctite® on the threads during assembly. Tighten all big twin and Sportster® model nuts to stock Harley-Davidson® factory specifications in cast iron flywheels. When using S&S forged flywheels, tighten big twin nuts to 400 ft. lbs. minimum and Sportster® models to 300-350 ft. lbs..

Preassembly Cleaning - Disassemble and thoroughly clean all parts in lacquer thinner to remove dirt, filings, etc. Pay particular attention to the crankpin oil passageways. Reassemble using high quality break-in grease.

Connecting Rod Alignment

After flywheel assembly has been installed in crankcase, rods should be checked for alignment. S&S Rod Checking Pin, Part 53-0002, was designed to help perform this procedure. It may also be necessary to fabricate a rod bending tool as illustrated in **Figure 2**. The purpose of this procedure is to compensate for machining tolerance discrepancies in component parts which may lead to pistons not running true in cylinder bores. While the rods are straight and true, it is sometimes necessary to bend them slightly to compensate for these conditions. **Figure 3** shows an exaggerated view.

NOTE: We feel that using a piston in lieu of a checking pin may prove inaccurate due to variations in lengths of piston skirts from one side of piston to the other.

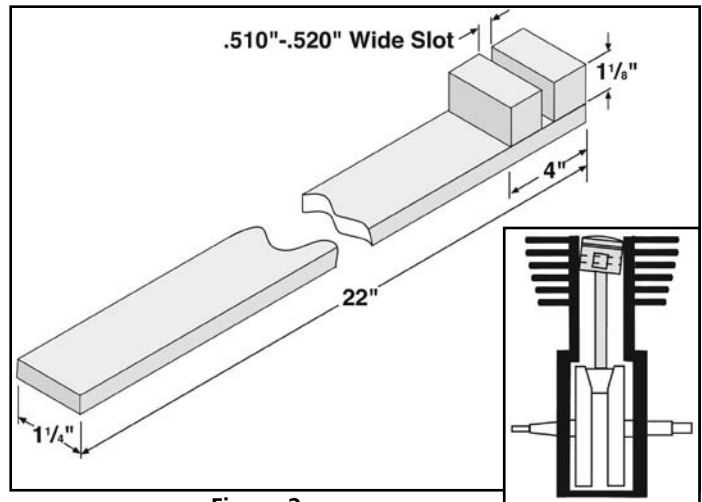

Figure 2

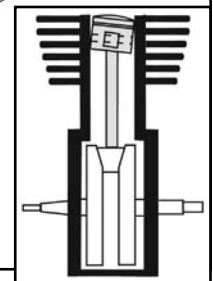

Figure 3

CAUTION

- Do not bend rod by using a tool in wristpin hole as this method may distort wristpin bushing.
- Failure to check and correct rod misalignment can lead to connecting rod thrusting and potential engine damage.

Checking Pin Procedure

1. Insert checking pin into wristpin hole. Place strips of paper between checking pin and crankcase cylinder gasket surface and apply slight downward pressure to wristpin end of rod by rotating flywheels. Pull papers out slowly. Drag on papers should be equal.
2. Rotate flywheels in opposite direction until checking pin contacts cylinder gasket surface again. Repeat procedure for same rod again. If drag on papers is equal no bending is required. If one paper is loose, use rod bending tool to tweak rod in direction of loose paper and recheck. See **Picture 1**.

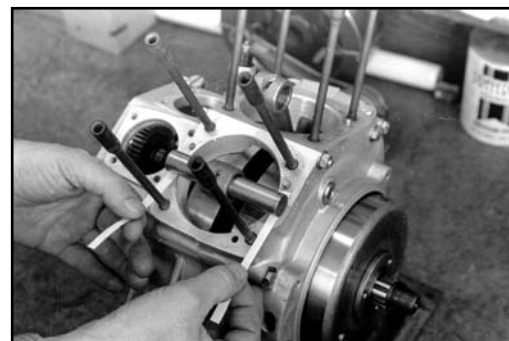

Picture 1

3. Repeat checking and bending procedure for other rod.

While disassembling an engine for rebuild or top end work, observe pistons for wear spots on sides above top compression ring. If one side near wristpin is worn clean while side opposite is carboned up, then piston was not running straight and true in cylinder bore. Piston will also generally show diagonal wear pattern on thrust faces of skirts and possibly signs of connecting rod to wristpin boss contact inside piston.

NOTE: We feel that not enough emphasis is given to checking piston alignment in the cylinder bore. More attention to this should result in better ring sealing and piston life while promoting less connecting rod side thrusting and longer rod bearing life.