



LG

Life's Good

North/Latin America
Europe/Africa
Asia/Oceania

Internal Use Only

<http://aic.lgservice.com>
<http://eic.lgservice.com>
<http://biz.lgservice.com>

LED LCD TV

SERVICE MANUAL

CHASSIS : LB22E

MODEL : 60LM6450 60LM6450-TA

CAUTION

BEFORE SERVICING THE CHASSIS,
READ THE SAFETY PRECAUTIONS IN THIS MANUAL.

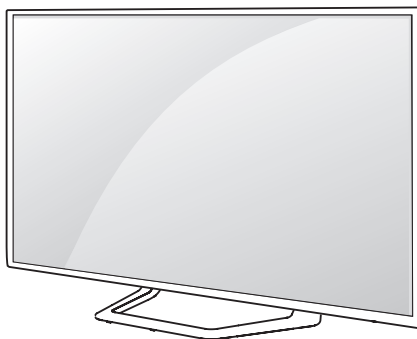

CONTENTS

CONTENTS	2
SAFETY PRECAUTIONS	3
SERVICING PRECAUTIONS	4
SPECIFICATION	6
ADJUSTMENT INSTRUCTION	9
BLOCK DIAGRAM	15
EXPLODED VIEW	16
SCHEMATIC CIRCUIT DIAGRAM	

SAFETY PRECAUTIONS

IMPORTANT SAFETY NOTICE

Many electrical and mechanical parts in this chassis have special safety-related characteristics. These parts are identified by \triangle in the Schematic Diagram and Exploded View.

It is essential that these special safety parts should be replaced with the same components as recommended in this manual to prevent Shock, Fire, or other Hazards.

Do not modify the original design without permission of manufacturer.

General Guidance

An **isolation Transformer should always be used** during the servicing of a receiver whose chassis is not isolated from the AC power line. Use a transformer of adequate power rating as this protects the technician from accidents resulting in personal injury from electrical shocks.

It will also protect the receiver and its components from being damaged by accidental shorts of the circuitry that may be inadvertently introduced during the service operation.

If any fuse (or Fusible Resistor) in this TV receiver is blown, replace it with the specified.

When replacing a high wattage resistor (Oxide Metal Film Resistor, over 1 W), keep the resistor 10 mm away from PCB.

Keep wires away from high voltage or high temperature parts.

Before returning the receiver to the customer,

always perform an **AC leakage current check** on the exposed metallic parts of the cabinet, such as antennas, terminals, etc., to be sure the set is safe to operate without damage of electrical shock.

Leakage Current Cold Check(Antenna Cold Check)

With the instrument AC plug removed from AC source, connect an electrical jumper across the two AC plug prongs. Place the AC switch in the on position, connect one lead of ohm-meter to the AC plug prongs tied together and touch other ohm-meter lead in turn to each exposed metallic parts such as antenna terminals, phone jacks, etc.

If the exposed metallic part has a return path to the chassis, the measured resistance should be between 1 M Ω and 5.2 M Ω .

When the exposed metal has no return path to the chassis the reading must be infinite.

An other abnormality exists that must be corrected before the receiver is returned to the customer.

Leakage Current Hot Check (See below Figure)

Plug the AC cord directly into the AC outlet.

Do not use a line Isolation Transformer during this check.

Connect 1.5 K / 10 watt resistor in parallel with a 0.15 uF capacitor between a known good earth ground (Water Pipe, Conduit, etc.) and the exposed metallic parts.

Measure the AC voltage across the resistor using AC voltmeter with 1000 ohms/volt or more sensitivity.

Reverse plug the AC cord into the AC outlet and repeat AC voltage measurements for each exposed metallic part. Any voltage measured must not exceed 0.75 volt RMS which corresponds to 0.5 mA.

In case any measurement is out of the limits specified, there is possibility of shock hazard and the set must be checked and repaired before it is returned to the customer.

Leakage Current Hot Check circuit

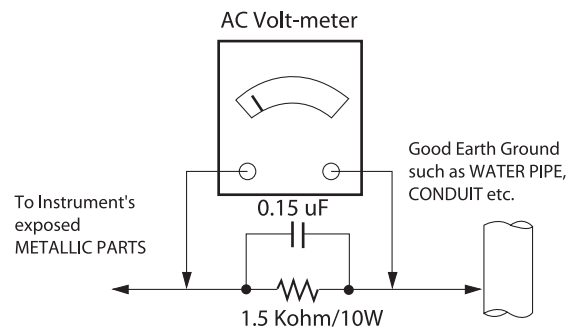

When 25A is impressed between Earth and 2nd Ground for 1 second, Resistance must be less than 0.1 Ω

*Base on Adjustment standard

SERVICING PRECAUTIONS

CAUTION: Before servicing receivers covered by this service manual and its supplements and addenda, read and follow the **SAFETY PRECAUTIONS** on page 3 of this publication.
NOTE: If unforeseen circumstances create conflict between the following servicing precautions and any of the safety precautions on page 3 of this publication, always follow the safety precautions. Remember: Safety First.

General Servicing Precautions

1. Always unplug the receiver AC power cord from the AC power source before;
 - a. Removing or reinstalling any component, circuit board module or any other receiver assembly.
 - b. Disconnecting or reconnecting any receiver electrical plug or other electrical connection.
 - c. Connecting a test substitute in parallel with an electrolytic capacitor in the receiver.
CAUTION: A wrong part substitution or incorrect polarity installation of electrolytic capacitors may result in an explosion hazard.
2. Test high voltage only by measuring it with an appropriate high voltage meter or other voltage measuring device (DVM, FETVOM, etc) equipped with a suitable high voltage probe. Do not test high voltage by "drawing an arc".
3. Do not spray chemicals on or near this receiver or any of its assemblies.
4. Unless specified otherwise in this service manual, clean electrical contacts only by applying the following mixture to the contacts with a pipe cleaner, cotton-tipped stick or comparable non-abrasive applicator; 10 % (by volume) Acetone and 90 % (by volume) isopropyl alcohol (90 % - 99 % strength)
CAUTION: This is a flammable mixture.
Unless specified otherwise in this service manual, lubrication of contacts is not required.
5. Do not defeat any plug/socket B+ voltage interlocks with which receivers covered by this service manual might be equipped.
6. Do not apply AC power to this instrument and/or any of its electrical assemblies unless all solid-state device heat sinks are correctly installed.
7. Always connect the test receiver ground lead to the receiver chassis ground before connecting the test receiver positive lead.
Always remove the test receiver ground lead last.
8. Use with this receiver only the test fixtures specified in this service manual.
CAUTION: Do not connect the test fixture ground strap to any heat sink in this receiver.

Electrostatically Sensitive (ES) Devices

Some semiconductor (solid-state) devices can be damaged easily by static electricity. Such components commonly are called Electrostatically Sensitive (ES) Devices. Examples of typical ES devices are integrated circuits and some field-effect transistors and semiconductor "chip" components. The following techniques should be used to help reduce the incidence of component damage caused by static by static electricity.

1. Immediately before handling any semiconductor component or semiconductor-equipped assembly, drain off any electrostatic charge on your body by touching a known earth ground. Alternatively, obtain and wear a commercially available discharging wrist strap device, which should be removed to prevent potential shock reasons prior to applying power to the unit under test.

2. After removing an electrical assembly equipped with ES devices, place the assembly on a conductive surface such as aluminum foil, to prevent electrostatic charge buildup or exposure of the assembly.
3. Use only a grounded-tip soldering iron to solder or unsolder ES devices.
4. Use only an anti-static type solder removal device. Some solder removal devices not classified as "anti-static" can generate electrical charges sufficient to damage ES devices.
5. Do not use freon-propelled chemicals. These can generate electrical charges sufficient to damage ES devices.
6. Do not remove a replacement ES device from its protective package until immediately before you are ready to install it. (Most replacement ES devices are packaged with leads electrically shorted together by conductive foam, aluminum foil or comparable conductive material).
7. Immediately before removing the protective material from the leads of a replacement ES device, touch the protective material to the chassis or circuit assembly into which the device will be installed.
CAUTION: Be sure no power is applied to the chassis or circuit, and observe all other safety precautions.
8. Minimize bodily motions when handling unpackaged replacement ES devices. (Otherwise harmless motion such as the brushing together of your clothes fabric or the lifting of your foot from a carpeted floor can generate static electricity sufficient to damage an ES device.)

General Soldering Guidelines

1. Use a grounded-tip, low-wattage soldering iron and appropriate tip size and shape that will maintain tip temperature within the range or 500 °F to 600 °F.
2. Use an appropriate gauge of RMA resin-core solder composed of 60 parts tin/40 parts lead.
3. Keep the soldering iron tip clean and well tinned.
4. Thoroughly clean the surfaces to be soldered. Use a mall wire-bristle (0.5 inch, or 1.25 cm) brush with a metal handle. Do not use freon-propelled spray-on cleaners.
5. Use the following unsoldering technique
 - a. Allow the soldering iron tip to reach normal temperature. (500 °F to 600 °F)
 - b. Heat the component lead until the solder melts.
 - c. Quickly draw the melted solder with an anti-static, suction-type solder removal device or with solder braid.
CAUTION: Work quickly to avoid overheating the circuit board printed foil.
6. Use the following soldering technique.
 - a. Allow the soldering iron tip to reach a normal temperature (500 °F to 600 °F)
 - b. First, hold the soldering iron tip and solder the strand against the component lead until the solder melts.
 - c. Quickly move the soldering iron tip to the junction of the component lead and the printed circuit foil, and hold it there only until the solder flows onto and around both the component lead and the foil.
CAUTION: Work quickly to avoid overheating the circuit board printed foil.
 - d. Closely inspect the solder area and remove any excess or splashed solder with a small wire-bristle brush.

IC Remove/Replacement

Some chassis circuit boards have slotted holes (oblong) through which the IC leads are inserted and then bent flat against the circuit foil. When holes are the slotted type, the following technique should be used to remove and replace the IC. When working with boards using the familiar round hole, use the standard technique as outlined in paragraphs 5 and 6 above.

Removal

1. Desolder and straighten each IC lead in one operation by gently prying up on the lead with the soldering iron tip as the solder melts.
2. Draw away the melted solder with an anti-static suction-type solder removal device (or with solder braid) before removing the IC.

Replacement

1. Carefully insert the replacement IC in the circuit board.
2. Carefully bend each IC lead against the circuit foil pad and solder it.
3. Clean the soldered areas with a small wire-bristle brush. (It is not necessary to reapply acrylic coating to the areas).

"Small-Signal" Discrete Transistor Removal/Replacement

1. Remove the defective transistor by clipping its leads as close as possible to the component body.
2. Bend into a "U" shape the end of each of three leads remaining on the circuit board.
3. Bend into a "U" shape the replacement transistor leads.
4. Connect the replacement transistor leads to the corresponding leads extending from the circuit board and crimp the "U" with long nose pliers to insure metal to metal contact then solder each connection.

Power Output, Transistor Device

Removal/Replacement

1. Heat and remove all solder from around the transistor leads.
2. Remove the heat sink mounting screw (if so equipped).
3. Carefully remove the transistor from the heat sink of the circuit board.
4. Insert new transistor in the circuit board.
5. Solder each transistor lead, and clip off excess lead.
6. Replace heat sink.

Diode Removal/Replacement

1. Remove defective diode by clipping its leads as close as possible to diode body.
2. Bend the two remaining leads perpendicular y to the circuit board.
3. Observing diode polarity, wrap each lead of the new diode around the corresponding lead on the circuit board.
4. Securely crimp each connection and solder it.
5. Inspect (on the circuit board copper side) the solder joints of the two "original" leads. If they are not shiny, reheat them and if necessary, apply additional solder.

Fuse and Conventional Resistor

Removal/Replacement

1. Clip each fuse or resistor lead at top of the circuit board hollow stake.
2. Securely crimp the leads of replacement component around notch at stake top.

3. Solder the connections.

CAUTION: Maintain original spacing between the replaced component and adjacent components and the circuit board to prevent excessive component temperatures.

Circuit Board Foil Repair

Excessive heat applied to the copper foil of any printed circuit board will weaken the adhesive that bonds the foil to the circuit board causing the foil to separate from or "lift-off" the board. The following guidelines and procedures should be followed whenever this condition is encountered.

At IC Connections

To repair a defective copper pattern at IC connections use the following procedure to install a jumper wire on the copper pattern side of the circuit board. (Use this technique only on IC connections).

1. Carefully remove the damaged copper pattern with a sharp knife. (Remove only as much copper as absolutely necessary).
2. Carefully scratch away the solder resist and acrylic coating (if used) from the end of the remaining copper pattern.
3. Bend a small "U" in one end of a small gauge jumper wire and carefully crimp it around the IC pin. Solder the IC connection.
4. Route the jumper wire along the path of the out-away copper pattern and let it overlap the previously scraped end of the good copper pattern. Solder the overlapped area and clip off any excess jumper wire.

At Other Connections

Use the following technique to repair the defective copper pattern at connections other than IC Pins. This technique involves the installation of a jumper wire on the component side of the circuit board.

1. Remove the defective copper pattern with a sharp knife. Remove at least 1/4 inch of copper, to ensure that a hazardous condition will not exist if the jumper wire opens.
2. Trace along the copper pattern from both sides of the pattern break and locate the nearest component that is directly connected to the affected copper pattern.
3. Connect insulated 20-gauge jumper wire from the lead of the nearest component on one side of the pattern break to the lead of the nearest component on the other side. Carefully crimp and solder the connections.

CAUTION: Be sure the insulated jumper wire is dressed so the it does not touch components or sharp edges.

SPECIFICATION

NOTE : Specifications and others are subject to change without notice for improvement.

1. Application range

This specification is applied to the LCD TV used LB22E chassis.

2. Requirement for Test

Each part is tested as below without special appointment.

- 1) Temperature: 25 °C ± 5 °C(77 °F ± 9 °F), CST: 40 °C ± 5 °C
- 2) Relative Humidity: 65 % ± 10 %
- 3) Power Voltage
: Standard input voltage (AC 100-240 V~, 50/60 Hz)
* Standard Voltage of each products is marked by models.
- 4) Specification and performance of each parts are followed each drawing and specification by part number in accordance with BOM.
- 5) The receiver must be operated for about 20 minutes prior to the adjustment.

3. Test method

- 1) Performance: LGE TV test method followed
- 2) Demanded other specification
 - Safety : CE, IEC specification
 - EMC : CE, IEC
 - Wireless : Wireless HD Specification (Option)

4. Model General Specification

No.	Item	Specification	Remarks
1.	Market	Asia, Oceania, Africa, Middle East (PAL/DVB Market)	Australia/New Zealand(AU), Singapore(SG), Indonesia(ID), Malaysia(MY), Vietnam(VN),South Africa(ZA), Iran(IR) - Considering for Israel(IL) only Analog for A-ASIA
2.	Broadcasting system	1) PAL/SECAM-B/G/D/K 2) PAL-I/II 3) NTSC-M 4) DVB-T	PAL for NZ/SG
3.	Channel Storage	ATV - 135EA, DTV - 1000EA	
4.	Receiving system	Analog : Upper Heterodyne Digital : COFDM(DVB-T)	▶ DVB-T - Guard Interval(Bitrate_Mbit/s) 1/4, 1/8, 1/16, 1/32 - Modulation : Code Rate QPSK : 1/2, 2/3, 3/4, 5/6, 7/8 16-QAM : 1/2, 2/3, 3/4, 5/6, 7/8 64-QAM : 1/2, 2/3, 3/4, 5/6, 7/8
5.	Video Input RCA	PAL, SECAM, NTSC	4 System : PAL, SECAM, NTSC, PAL60
6.	Component Input	Y/Cb/Cr, Y/Pb/Pr	
7.	RGB Input	RGB-PC	Analog(D-SUB 15PIN)
8.	HDMI Input	HDMI1-DTV/DVI,HDMI2-DTV/DVI HDMI3-DTV/DVI,HDMI4-DTV/DVI	PC(HDMI Ver. 1.4) Support HDCP
9.	Audio Input	RGB/DVI Audio Component AV	
10.	SPDIF out	SPDIF out	
11	USB Input	For My Media(Movie/Photo/Music List) or For SVC	

5. Component Video Input (Y, CB/PB, CR/PR)

No.	Resolution	H-freq(kHz)	V-freq(Hz)	Porposed
1	720×480	15.73	60.00	SDTV, DVD 480i
2	720×480	15.63	59.94	SDTV, DVD 480i
3	720×480	31.47	59.94	480p
4	720×480	31.50	60.00	480p
5	720×576	15.625	50.00	SDTV, DVD 625 Line
6	720×576	31.25	50.00	HDTV 576p
7	1280×720	45.00	50.00	HDTV 720p
8	1280×720	44.96	59.94	HDTV 720p
9	1280×720	45.00	60.00	HDTV 720p
10	1920×1080	31.25	50.00	HDTV 1080i
11	1920×1080	33.75	60.00	HDTV 1080i
12	1920×1080	33.72	59.94	HDTV 1080i
13	1920×1080	56.250	50	HDTV 1080p
14	1920×1080	67.5	60	HDTV 1080p

6. RGB input (PC)

No.	Resolution	H-freq(kHz)	V-freq.(Hz)	Proposed	Remark
1	640 x 350 @70Hz	31.468	70.09	EGA	
2	720 x 400 @70Hz	31.469	70.08	DOS	
3	640 x 480 @60Hz	31.469	59.94	VESA(VGA)	
4	800 x 600 @60Hz	37.879	60.31	VESA(SVGA)	
5	1024 x 768 @60Hz	48.363	60	VESA(XGA)	
6	1152 x 864 @60Hz	54.348	60.053	VESA	
7	1360 x 768 @60Hz	47.712	60.015	VESA(WXGA)	
8	1920 x 1080 @60Hz	67.5	60	WUXGA(CEA 861D)	FHD only

7. HDMI Input

7.1. DTV mode

No.	Resolution	H-freq(kHz)	V-freq.(kHz)	Proposed	Proposed
1.	720*480	31.469 / 31.5	59.94 / 60	27.00/27.03	SDTV 480P
2.	720*576	31.25	50	54	SDTV 576P
3.	1280*720	37.500	50	74.25	HDTV 720P
4.	1280*720	44.96 / 45	59.94 / 60	74.17/74.25	HDTV 720P
5.	1920*1080	33.72 / 33.75	59.94 / 60	74.17/74.25	HDTV 1080I
6.	1920*1080	28.125	50.00	74.25	HDTV 1080I
7.	1920*1080	26.97 / 27	23.97 / 24	74.17/74.25	HDTV 1080P
8.	1920*1080	33.716/ 33.75	29.976/30.00	74.25	HDTV 1080P
9.	1920*1080	56.250	50	148.5	HDTV 1080P
10.	1920*1080	67.43 / 67.5	59.94 / 60	148.35/148.50	HDTV 1080P

7.2. PC mode

No.	Resolution	H-freq(kHz)	V-freq.(Hz)	Proposed	Remark
1	640 x 350 @70Hz	31.468	70.09	EGA	
2	720 x 400 @70Hz	31.469	70.08	DOS	
3	640 x 480 @60Hz	31.469	59.94	VESA(VGA)	
4	800 x 600 @60Hz	37.879	60.31	VESA(SVGA)	
5	1024 x 768 @60Hz	48.363	60	VESA(XGA)	
6	1152 x 864 @60Hz	54.348	60.053	VESA	
7	1280 x 1024 @60Hz	63.981	60.02	VESA(SXGA)	FHD only(Support to HDMI-PC)
8	1360 x 768 @60Hz	47.712	60.015	VESA(WXGA)	
9	1920 x 1080 @60Hz	67.5	60	WUXGA(CEA 861D)	FHD only

ADJUSTMENT INSTRUCTION

1. Application Range

This specification sheet is applied to all of the LED LCD TV with LB22E chassis.

2. Designation

- (1) The adjustment is according to the order which is designated and which must be followed, according to the plan which can be changed only on agreeing.
- (2) Power adjustment : Free Voltage.
- (3) Magnetic Field Condition: Nil.
- (4) Input signal Unit: Product Specification Standard.
- (5) Reserve after operation: Above 5 Minutes (Heat Run)
 - Temperature : at 25 °C ± 5 °C
 - Relative humidity : 65 ± 10 %
 - Input voltage : 220 V, 60 Hz

In case of keeping module is in the circumstance of 0 °C, it should be placed in the circumstance of above 15 °C for 2 hours

In case of keeping module is in the circumstance of below -20 °C, it should be placed in the circumstance of above 15 °C for 3 hours.

- (6) Adjustment equipments: Color Analyzer (CA-210 or CA-110), DDC Adjustment Jig equipment, Service remote control.
- (7) Push the "IN STOP" key - For memory initialization.

Case1 : Software version up

1. After downloading S/W by USB , TV set will reboot automatically.
2. Push "In-stop" key.
3. Push "Power on" key.
4. Function inspection
5. After function inspection, Push "In-stop" key.

Case2 : Function check at the assembly line

1. When TV set is entering on the assembly line, Push "In-stop" key at first.
2. Push "Power on" key for turning it on.
 - If you push "Power on" key, TV set will recover channel information by itself.
3. After function inspection, Push "In-stop" key.

3. Main PCB check process

- APC - After Manual-Insert, executing APC

* Boot file Download

- (1) Execute ISP program "Mstar ISP Utility" and then click "Config" tab.
- (2) Set as below, and then click "Auto Detect" and check "OK" message.
If "Error" is displayed, check connection between computer, jig, and set.
- (3) Click "Read" tab, and then load download file(XXXX.bin) by clicking "Read"

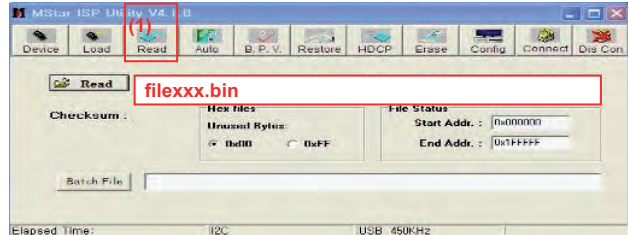

- (4) Click "Connect" tab. If "Can't" is displayed, check connection between computer, jig, and set.

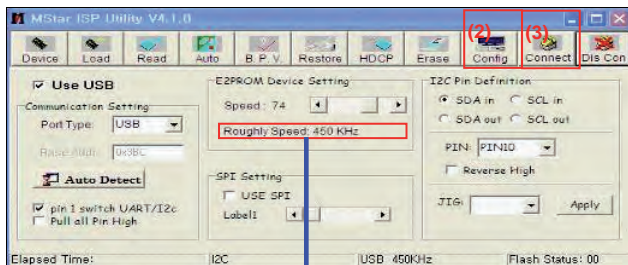

Please Check the Speed :
To use speed between
from 200KHz to 400KHz

- (5) Click "Auto" tab and set as below.
- (6) Click "Run".
- (7) After downloading, check "OK" message.

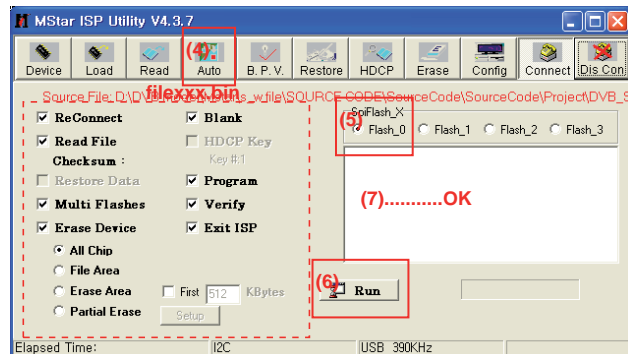

*** USB DOWNLOAD(*.epk file download)**

- (1) Put the USB Stick to the USB socket.
- (2) Automatically detecting update file in USB Stick.
 - If your downloaded program version in USB Stick is Low, it didn't work. But your downloaded version is High, USB data is automatically detecting.
- (3) Show the message "Copying files from memory".

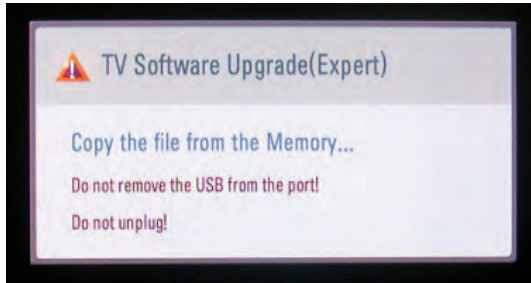

- (4) Updating is starting.

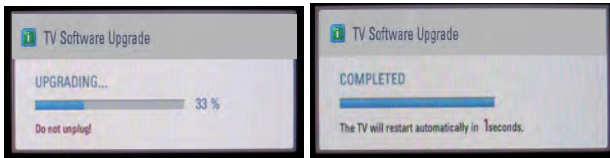

- (5) Updating Completed, The TV will restart automatically.
 - (6) If your TV is turned on, check your updated version and Tool option. (explain the Tool option, next stage)
- * If downloading version is more high than your TV have, TV can lost all channel data. In this case, you have to channel recover. if all channel data is cleared, you didn't have a DTV/ATV test on production line.

*** After downloading, have to adjust Tool Option again.**

- (1) Push "IN-START" key in service remote control.
- (2) Select "Tool Option 1" and push "OK" key.
- (3) Punch in the number. (Each model has their number)

3.1. ADC Process

- Enter Service Mode by pushing "ADJ" key,
- Enter ADC mode by pushing "▶" key at "8. ADC Calibration".
- There are 2 ways for ADC Calibration.(OTP, External)

OTP mode: Automatic ADC Calibration.(Internal ADC Calibration)
On the manufacture line, OTP is used for ADC Calibration automatically.

Externl mode: Manual ADC Calibration. When OTP mode is failed, ADC calibration should be "OK" by using External mode.

3.1.1. OTP mode

- (1) Press "ADJ" key on the Adjustment Remote Control, then select "8. ADC Calibration". By pressing Enter key, enter ADC Calibration menu.
- (2) Set up the ADC Type to OTP, then Select [Start] button by pressing Enter key, Component and RGB are Written and display Success or NG.

3.1.2. External mode

- * Equipment: MSPG-925 series Pattern Generator , RS-232C Jig
- (1) Input the signal for TV SET by using Pattern Generator (Model : 225, Pattern No : 65)_1080P
- (2) Change the ADC type "External" by using "▶"key.
- (3) Enter "Start" key.
- (4) Check the sign "OK" all of comp/RGB.

- Pattern : Horizontal 100% Color Bar Pattern
- Pattern level : 0.7±0.1 Vp-p
- Image

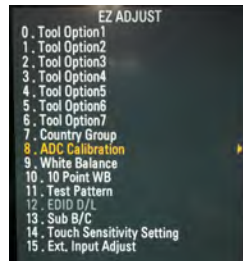
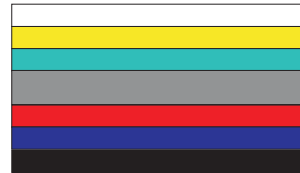

<Caution> Using "P-ONLY" key of the Adjustment remote control, power on TV.

*** ADC Calibration Protocol (RS232)**

NO	Item	CMD 1	CMD 2	Data 0	
Enter Adjust MODE	Adjust 'Mode In'	A	A	0 0	When transfer the 'Mode In', Carry the command.
ADC adjust	ADC Adjust	A	D	1 0	Automatically adjustment (The use of a internal pattern)

Adjust Sequence

- aa 00 00 [Enter Adjust Mode]
- xb 00 40 [Component1 Input (480i)]
- ad 00 10 [Adjust 480i Comp1]
- xb 00 60 [RGB Input (1024*768)]
- ad 00 10 [Adjust 1024*768 RGB]
- aa 00 90 End Adjust mode

* Required equipment : Adjustment remote control.

3.2 Function Check

3.2.1. Check display and sound

- Check Input and Signal items.

- (1) TV
- (2) AV (SCART1/SCART2/ CVBS)
- (3) COMPONENT (480i)
- (4) RGB (PC : 1024 x 768 @ 60hz)
- (5) HDMI
- (6) PC Audio In

* Display and Sound check is executed by Remote control.

<Caution>

Not to push the "INSTOP" key after completion if the function inspection.

4. Total Assembly line process

4.1. Adjustment Preparation

- W/B Equipment condition
CA210
: CCFL/EEFL -> CH9, Test signal: Inner pattern(80IRE)
LED -> CH14, Test signal: Inner pattern(80IRE)
- Above 5 minutes H/run in the inner pattern. ("power on" key of Adjustment remote control)(Only EEFL)

Cool	13,000 K	X=0.269 (±0.002) Y=0.273 (±0.002)	<Test Signal> Inner pattern (204gray, 80IRE)
Medium	9,300 K	X=0.285 (±0.002) Y=0.293 (±0.002)	
Warm	6,500 K	X=0.313 (±0.002) Y=0.329 (±0.002)	

* White Balance table.

- Edge LED module change color coordinate because of aging time
- Apply under the color coordinate table, for compensated aging time

GP4	Aging time (Min)	Cool		Medium		Warm	
		X	y	x	y	x	y
		269	273	285	293	313	329
1	0-2	280	287	296	307	320	337
2	3-5	279	285	295	305	319	335
3	6-9	277	284	293	304	317	334
4	10-19	276	283	292	303	316	333
5	20-35	274	280	290	300	314	330
6	36-49	272	277	288	297	312	327
7	50-79	271	275	287	295	311	325
8	80-119	270	274	286	294	310	324
9	Over 120	269	273	285	293	309	323

* Connecting picture of the measuring instrument (On Automatic control)

Inside PATTERN is used when W/B is controlled. Connect to auto controller or push Adjustment R/C POWER ON -> Enter the mode of White-Balance, the pattern will come out.

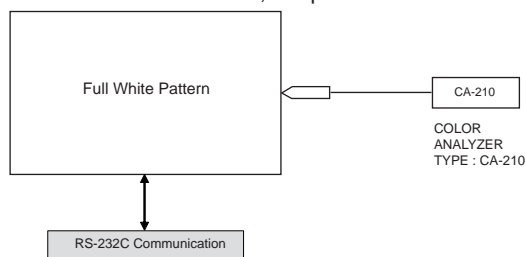

* Auto-control interface and directions

- Adjust in the place where the influx of light like floodlight around is blocked. (Illumination is less than 10 lux).
- Adhere closely the Color analyzer(CA210) to the module less than 10 cm distance, keep it with the surface of the Module and Color analyzer's probe vertically.(80° ~ 100°).
- Aging time
 - After aging start, keep the power on (no suspension of power supply) and heat-run over 5 minutes.
 - Using 'no signal' or 'POWER ONLY' or the others, check the back light on.

* Auto adjustment Map(RS-232C)

RS-232C COMMAND

[CMD ID DATA]

Wb 00 00 White Balance Start

Wb 00 ff White Balance End

	RS-232C COMMAND [CMD ID DATA]			MIN	CENTER (DEFAULT)			MAX
	Cool	Mid	Warm		Cool	Mid	Warm	
R Gain	jd	Ja	jd	00	172	192	192	192
G Gain	jh	Jb	je	00	172	192	192	192
B Gain	ji	Jc	jf	00	192	192	172	192
R Cut					64	64	64	128
G Cut					64	64	64	128
B Cut					64	64	64	128

<Caution>

Color Temperature : COOL, Medium, Warm.

One of R Gain/G Gain/ B Gain should be kept on 0xC0, and adjust other two lower than C0.(When R/G/B Gain are all C0, it is the FULL Dynamic Range of Module)

* Manual W/B process using adjust Remote control.

- After enter Service Mode by pushing "ADJ" key,
- Enter White Balance by pushing "►" key at "9. White Balance".



- After you finished all adjustments, Press "In-start" key and compare Tool option and Area option value with its BOM, if it is correctly same then unplug the AC cable. If it is not same, then correct it same with BOM and unplug AC cable. For correct it to the model's module from factory Jig model.
- Push the "IN STOP" key after completing the function inspection. And Mechanical Power Switch must be set "ON".

4.2. DPM operation confirmation

(Only Apply for MNT Model)

Check if Power LED Color and Power Consumption operate as standard.

- Set Input to RGB and connect D-sub cable to set
- Measurement Condition: (100~240V@ 50/60Hz)
- Confirm DPM operation at the state of screen without Signal

4.3. DDC EDID Write (RGB 128Byte)

- Connect D-sub Signal Cable to D-Sub Jack.
- Write EDID DATA to EEPROM(24C02) by using DDC2B protocol.
- Check whether written EDID data is correct or not.

* For SVC main Assembly, EDID have to be downloaded to Insert Process in advance.

4.4. DDC EDID Write (HDMI 256Byte)

- Connect HDMI Signal Cable to HDMI Jack.
- Write EDID DATA to EEPROM(24C02) by using DDC2B protocol.
- Check whether written EDID data is correct or not.

* For SVC main Assembly, EDID have to be downloaded to Insert Process in advance.

4.5. EDID DATA

1) All Data : HEXA Value

2) Changeable Data :

*: Serial No : Controlled / Data:01

** : Month : Controlled / Data:00

*** : Year : Controlled

**** : Check sum

4.5.1. Auto Download

- When you turn on the TV, EDID will set automatically. _Not operate

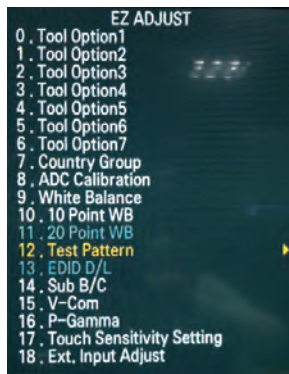

<Caution>

Never connect HDMI & D-sub Cable when EDID downloaded.

- Edid data and Model option download (RS232)

NO	Item	CMD 1	CMD 2	Data 0	
Enter download Mode	Download 'Mode In'	A	A	0 0	When transfer the 'Mode In', Carry the command.
EDID data and Model option download	ADC Adjust	A	E	00 10	Automatically adjustment (The use of a internal pattern)

4.5.2. Manual Download

<Caution>

- 1) Use the proper signal cable for EDID Download
 - Analog EDID : Pin3 exists
 - Digital EDID : Pin3 exists
- 2) Never connect HDMI & D-sub Cable at the same time.
- 3) Use the proper cables below for EDID Writing.
- 4) Download HDMI1, HDMI2 separately because HDMI1 is different from HDMI2.

For Analog		For HDMI EDID	
D-sub to D-sub		DVI-D to HDMI or HDMI to HDMI	
No.	Item	Condition	Hex Data
1	Manufacturer ID	GSM	1E6D
2	Version	Digital : 1	01
3	Revision	Digital : 3	03

(1) 3D FHD RGB EDID data (xvYCC : OFF)

	0x00	0x01	0x02	0x03	0x04	0x05	0x06	0x07	0x08	0x09	0x0A	0x0B	0x0C	0x0D	0x0E	0x0F
0x00	00	FF	FF	FF	FF	FF	FF	00	1E	6D	a		b			
0x01	c	01	03	68	A0	5A	78	0A	EE	91	A3	54	4C	99	26	
0x02	0F	50	54	A1	08	00	31	40	45	40	61	40	71	40	81	80
0x03	01	01	01	01	01	01	02	3A	80	18	71	38	2D	40	58	2C
0x04	45	00	A0	5A	00	00	00	1E	66	21	50	B0	51	00	1B	30
0x05	40	70	36	00	A0	5A	00	00	1E	00	00	00	FD	00	3A	
0x06	3E	1E	53	10	00	0A	20	20	20	20	20	d				
0x07	d														01	e3

(2) 3D FHD RGB EDID data (xvYCC : OFF)

	0x00	0x01	0x02	0x03	0x04	0x05	0x06	0x07	0x08	0x09	0x0A	0x0B	0x0C	0x0D	0x0E	0x0F
0x00	00	FF	FF	FF	FF	FF	FF	00	1E	6D	a		b			
0x01	c	01	03	80	A0	5A	78	0A	EE	91	A3	54	4C	99	26	
0x02	0F	50	54	A1	08	00	31	40	45	40	61	40	71	40	81	80
0x03	01	01	01	01	01	01	02	3A	80	18	71	38	2D	40	58	2C
0x04	45	00	A0	5A	00	00	00	1E	66	21	50	B0	51	00	1B	30
0x05	40	70	36	00	A0	5A	00	00	1E	00	00	00	FD	00	3A	
0x06	3E	1E	53	10	00	0A	20	20	20	20	20	d				
0x07	d														01	e1
0x08	02	03	37	F1	4E	10	9F	04	13	05	14	03	02	12	20	21
0x09	22	15	01	26	15	07	50	09	57	07	f					
0x0A	f															
0x0B	f			E3	05	03	01	02	3A	80	18	71	38	2D	40	58
0x0C	2C	45	00	A0	5A	00	00	1E	01	1D	80	18	71	1C	16	
0x0D	20	58	2C	25	00	A0	5A	00	00	00	9E	01	1D	00	72	51
0x0E	D0	1E	20	6E	28	55	00	A0	5A	00	00	00	1E	00	00	00
0x0F	00	00	00	00	00	00	00	00	00	00	00	00	00	00	00	e2

(3) Detail EDID Options are below

a. Product ID

HEX	EDID Table	DDC Function
0001	01 00	Analog/Digital

b. Serial No: Controlled on production line.

c. Month, Year: Controlled on production line:

ex) Week : '01' -> '01'

Year : '2012' -> '16' fix

d. Model Name(Hex):

cf) TV set's model name in EDID data is below.

MODEL NAME	MODEL NAME(HEX)
LG TV	00 00 00 FC 00 4C 47 20 54 56 0A 20 20 20 20 20 20 (LG TV)

e. Checksum: Changeable by total EDID data.

3D FHD Model	e1	e2	e3
HDMI1	43	15	X
HDMI2	43	05	X
HDMI3	43	F5	X
HDMI4	43	E5	X
RGB	X	X	5C

f. Vendor Specific(HDMI)

- 3D FHD model (3D_xvYCC_OFF & 3D_xvYCC_ON)

Input	Model name(HEX)
HDMI1	78 03 0C 00 10 00 B8 2D 20 C0 0E 01 4F 3F FC 08 10 18 10 06 10 16 10 28 10
HDMI2	78 03 0C 00 20 00 B8 2D 20 C0 0E 01 4F 3F FC 08 10 18 10 06 10 16 10 28 10
HDMI3	78 03 0C 00 30 00 B8 2D 20 C0 0E 01 4F 3F FC 08 10 18 10 06 10 16 10 28 10
HDMI4	78 03 0C 00 40 00 B8 2D 20 C0 0E 01 4F 3F FC 08 10 18 10 06 10 16 10 28 10

4.6. Model name & Serial number D/L

- Press "Power on" key of service remote control. (Baud rate : 115200 bps)
- Connect RS232 Signal Cable to RS-232 Jack.
- Write Serial number by use RS-232.
- Must check the serial number at the Product/Service info.. (menu key → red key → select product/Service info)

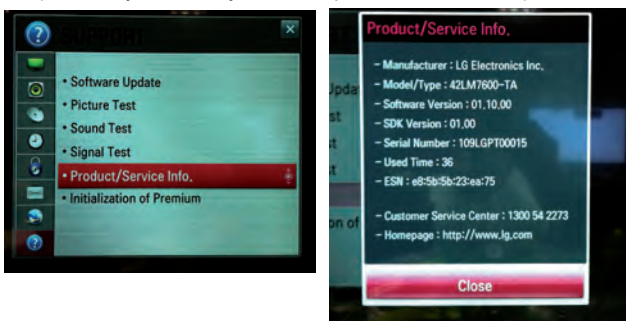

4.6.1. Signal Table

CMD	LENGTH	ADH	ADL	DATA_1	...	Data_n	CS	DELAY
-----	--------	-----	-----	--------	-----	--------	----	-------

CMD : A0h

LENGTH : 85~94h (1~16 bytes)

ADH : EEPROM Sub Address high (00~1F)

ADL : EEPROM Sub Address low (00~FF)

Data : Write data

CS : CMD + LENGTH + ADH + ADL + Data_1 + ... + Data_n

Delay : 20ms

4.6.2. Comand Set

Adjust mode	CMD(hex)	LENGTH(hex)	Description
EEPROM WRITE	A0h	84h+n	n-bytes Write (n = 1~16)

* Description

FOS Default write : <7mode data> write

Vtotal, V_Frequency, Sync_Polarity, Htotal, Hstart, Vstart, 0, Phase

Data write : Model Name and Serial Number write in EEPROM..

4.6.3. Method & notice

- Serial number D/L is using of scan equipment.
- Setting of scan equipment operated by Manufacturing Technology Group.
- Serial number D/L must be conformed when it is produced in production line, because serial number D/L is mandatory by D-book 4.0.

* Manual Download(Model Name and Serial Number)

If the TV set is downloaded by OTA or Service man, sometimes model name or serial number is initialized.(Not always)

There is impossible to download by bar code scan, so It need Manual download.

- Press the "Instart" key of Adjustment remote control.
- Go to the menu "7.Model Number D/L" like below photo.
- Input the Factory model name or Serial number like photo.

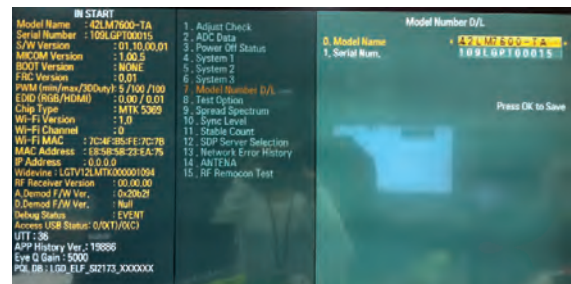

- Check the model name Instart menu. → Factory name displayed.
- Check the Product/Service info..(Menu Key → Support → Select Product/Service Info.) → Buyer model displayed.

4.7. Local Dimming Function Check

Step 1) Turn on TV and push the "Tilt" Key on Remote control in Power Only Mode.

Step 2) At the Local Dimming mode, module Edge Backlight moving right to left Back light of IOP module moving

Step 3) confirm the Local Dimming mode

Step 4) Press "exit" Key



Local Dimming Demo
(Edge LED Model)

4.8. 3D function test

(Pattern Generator MSHG-600, MSPG-6100[Support HDMI1.4])
 * HDMI mode No. 872 , pattern No.83
 (1) Please input 3D test pattern like below.



(2) When 3D OSD appear automatically, then select OK key.



(3) Don't wear a 3D Glasses, check the picture like below.



4.9. Wi-Fi Test

Step 1) Turn on TV.
 Step 2) Select Network Connection option in Network Menu.

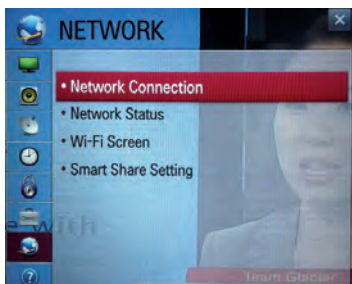

Step 3) Select Start Connection button in Network Connection.



Step 4) If the system finds any AP like blow PIC, it is working well.

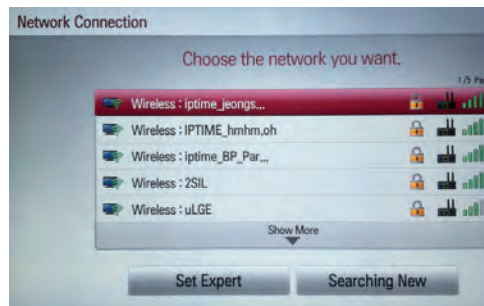

4.10. Magic Motion Remote control test

- (1) Equipment : RF Remote control for test, IR-KEY-Code Remote control for test
- (2) You must confirm the battery power of RF-Remote control before test(recommend that change the battery per every lot)
- (3) Sequence (test)
 - 1) if you select the "Start(OK)" key on the Adjustment remote control, you can pairing with the TV SET.
 - 2) You can check the cursor on the TV Screen, when select the "OK" key on the Adjustment remote control.
 - 3) You must remove the pairing with the TV Set by select "OK" key + "Mute" key on the Adjustment remote control.

4.11. Outgoing condition Configuration

- When pressing IN-STOP key by Service remote control, Red LED are blinked alternatively. And then automatically turn off. (Must not AC power OFF during blinking)

BLOCK DIAGRAM

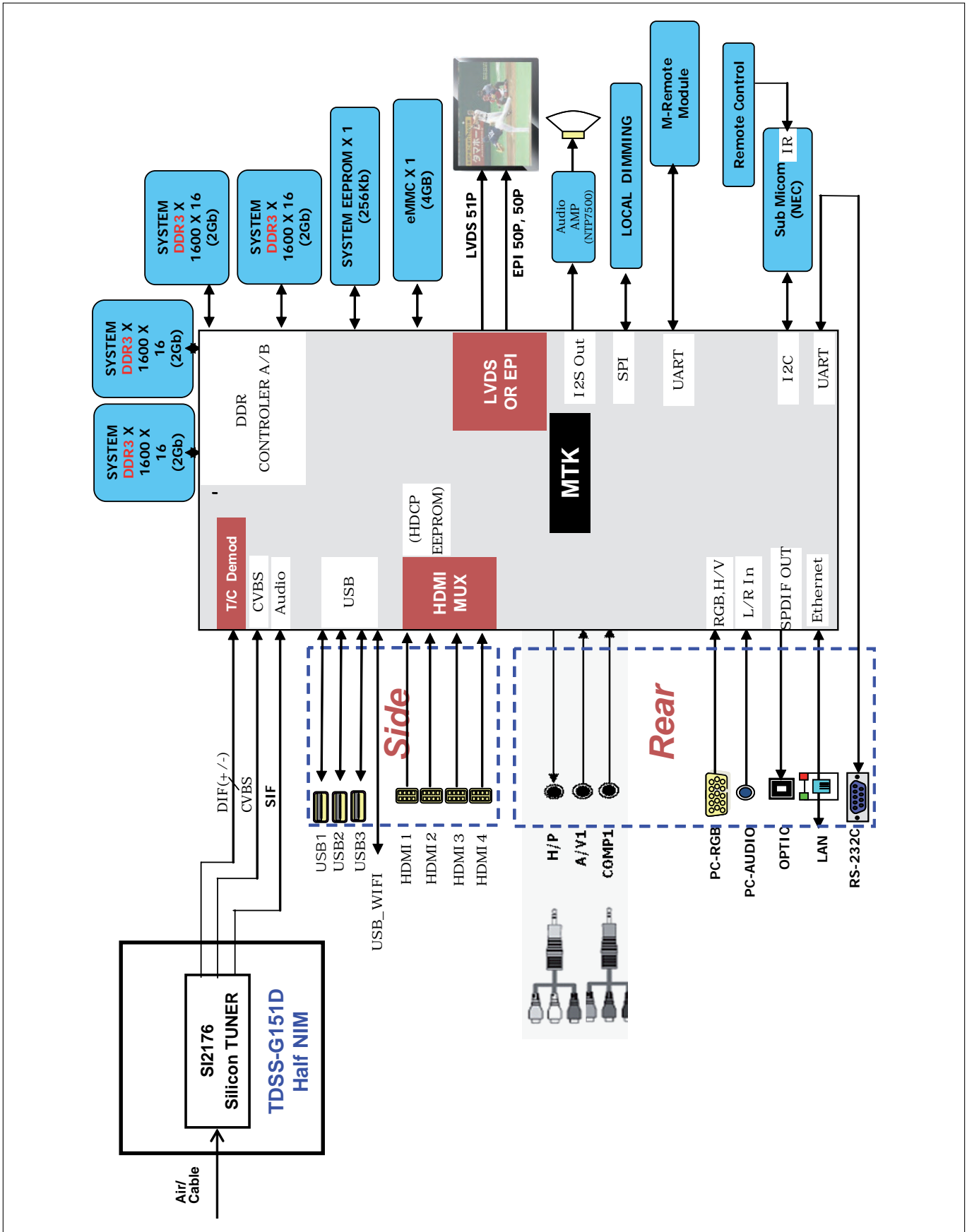

EXPLODED VIEW

IMPORTANT SAFETY NOTICE

Many electrical and mechanical parts in this chassis have special safety-related characteristics. These parts are identified by Δ in the Schematic Diagram and EXPLODED VIEW. It is essential that these special safety parts should be replaced with the same components as recommended in this manual to prevent X-RADIATION, Shock, Fire, or other Hazards. Do not modify the original design without permission of manufacturer.

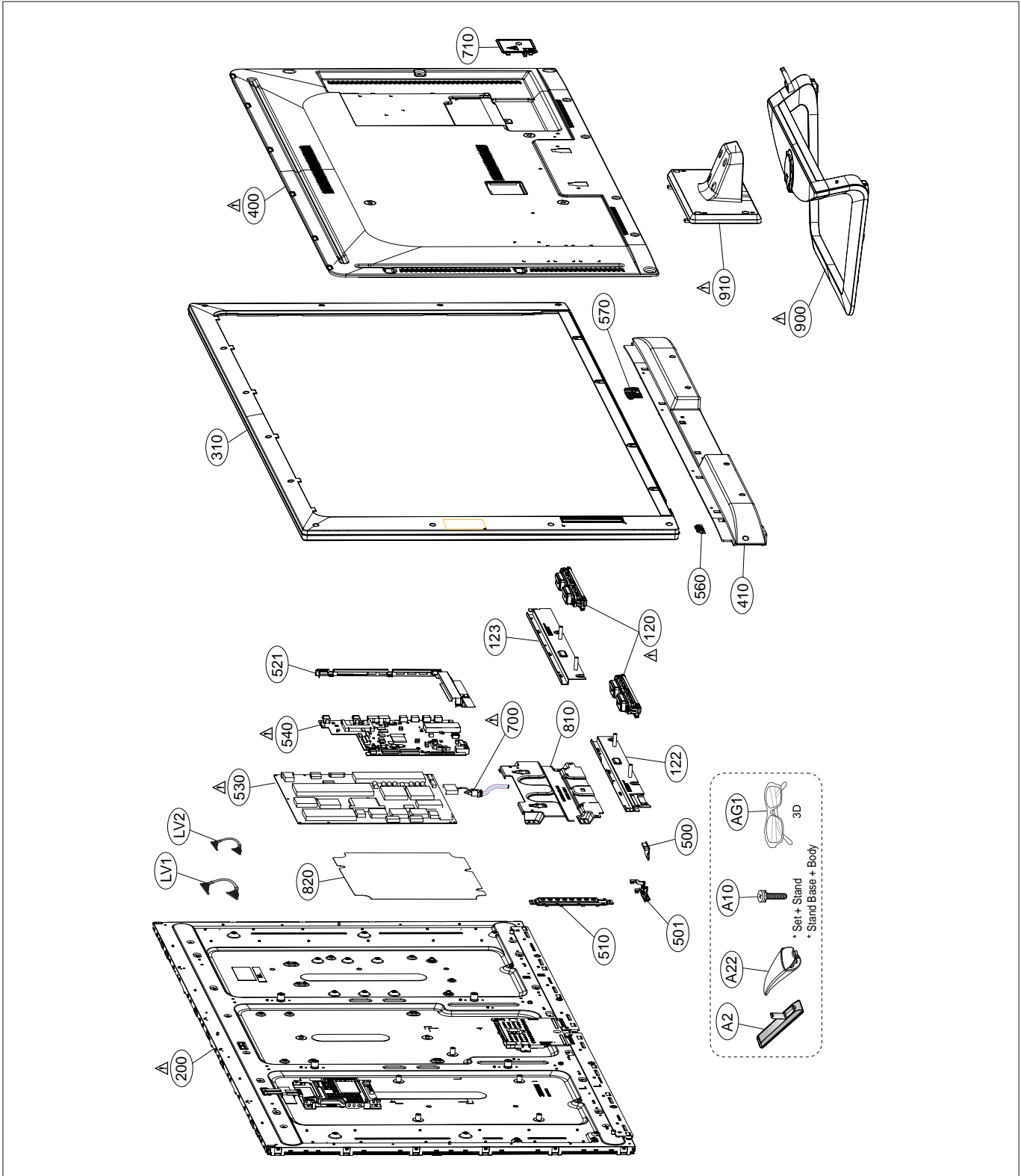

EAX6430790* : LD22* / LC22*
 EAX6443420* : LT22* / LJ22* / LA22* / LB22*

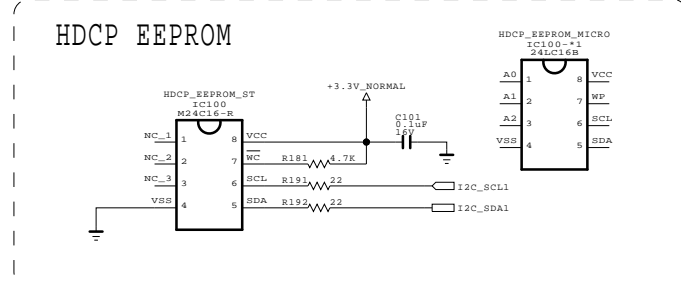
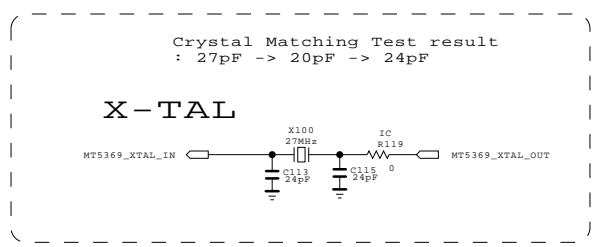
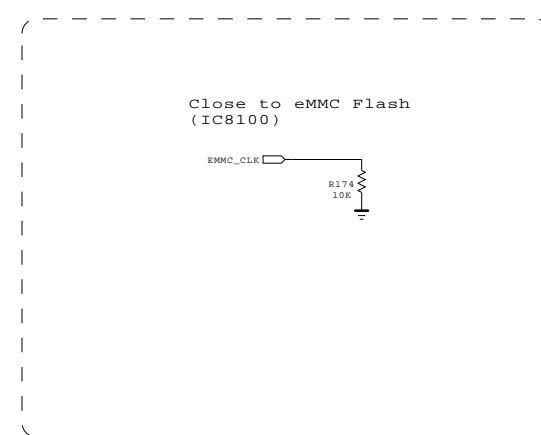
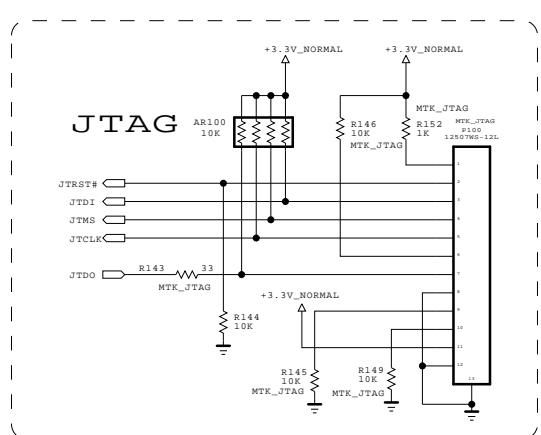
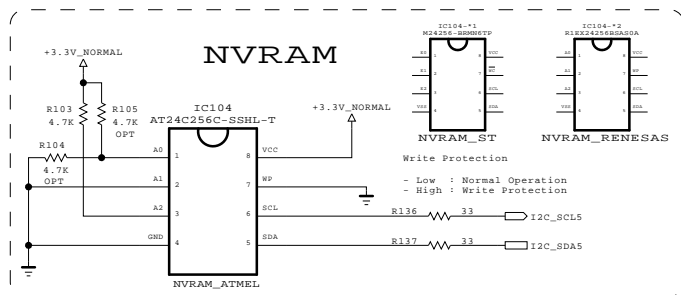

PLACE AT JACK SIDE

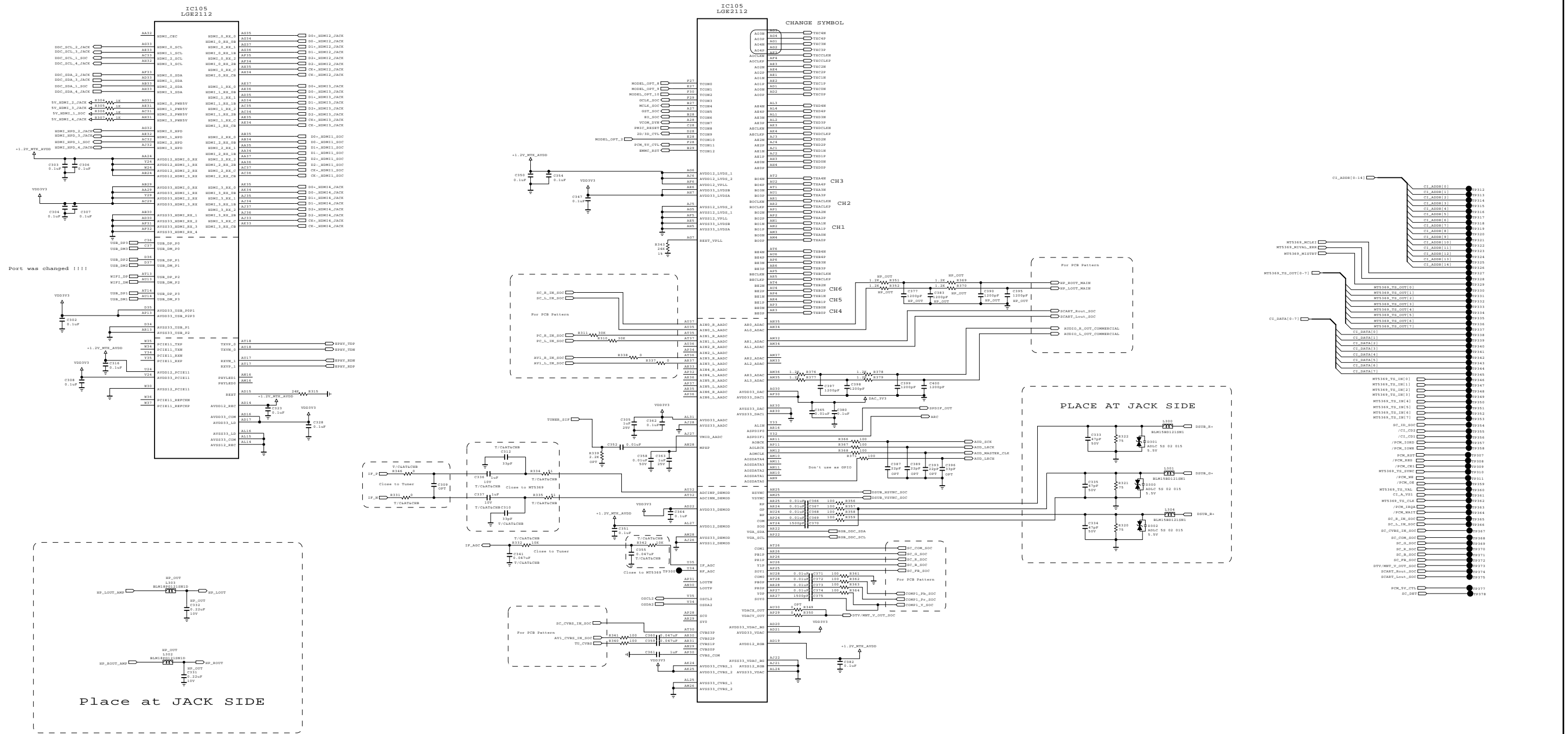
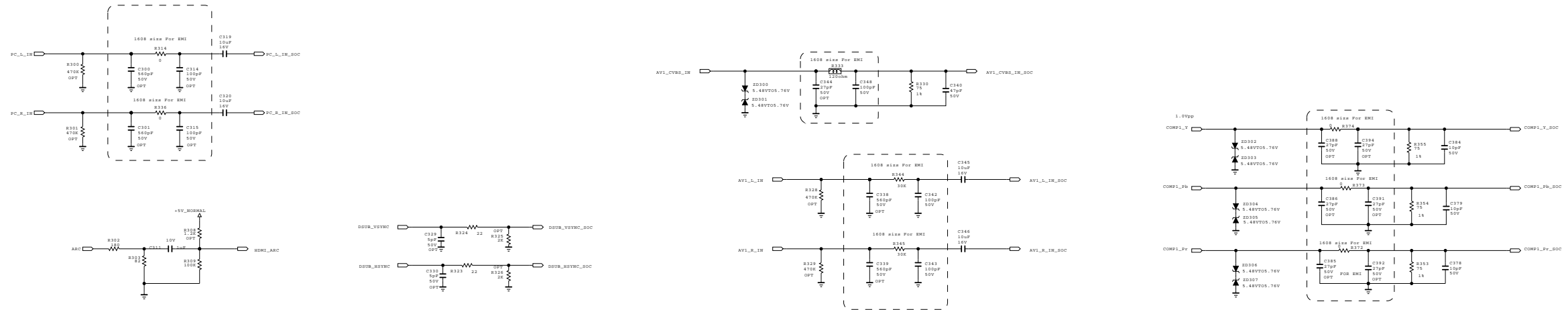

THE SYMBOL MARK OF THIS SCHEMATIC DIAGRAM INCORPORATES SPECIAL FEATURES IMPORTANT FOR PROTECTION FROM X-RADIATION. FILTRER AND ELECTRICAL SHOCK HAZARDS, WHEN SERVICING IT IS ESSENTIAL THAT ONLY MANUFACTURERS SPECIFIED PARTS BE USED FOR THE CRITICAL COMPONENTS IN THE SYMBOL MARK OF THE SCHEMATIC.

SECRET
LGElectronics

LG ELECTRONICS

MODEL	MID_MAIN_2	DATE	2011.12.09
BLOCK		SHEET	9

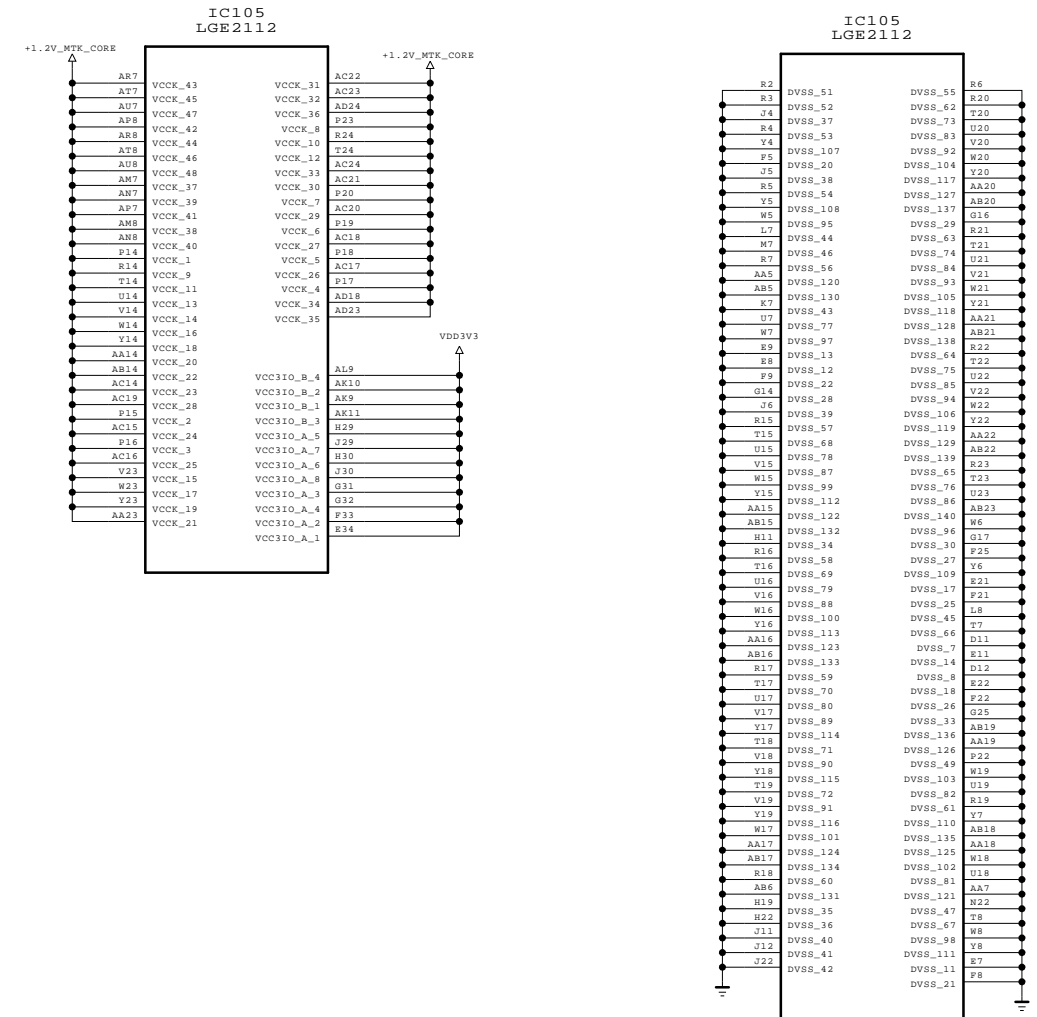
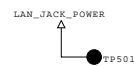
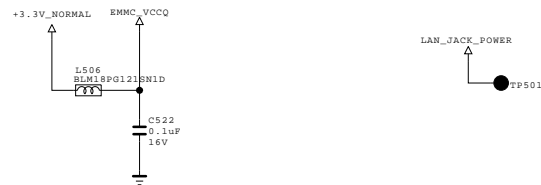
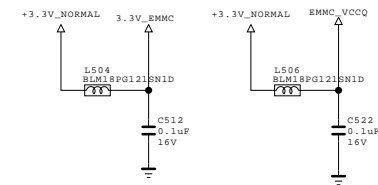
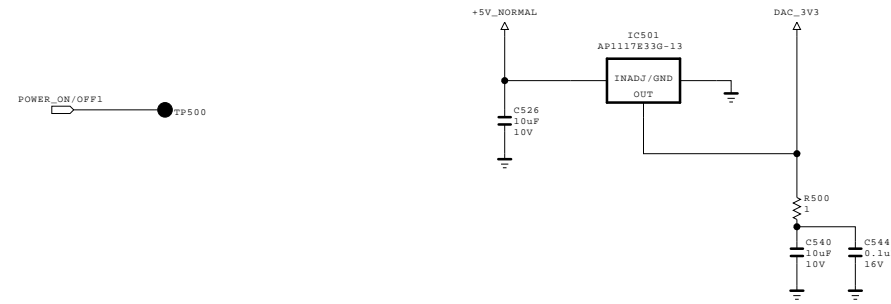
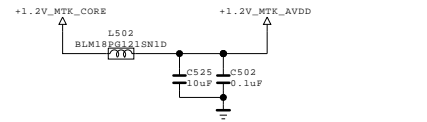
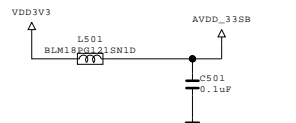
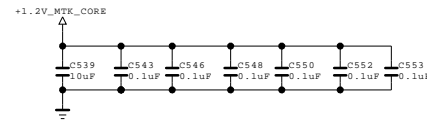
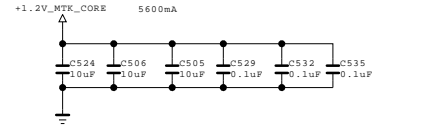
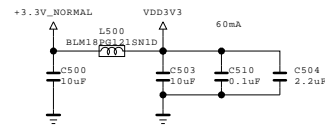

SMD Gasket

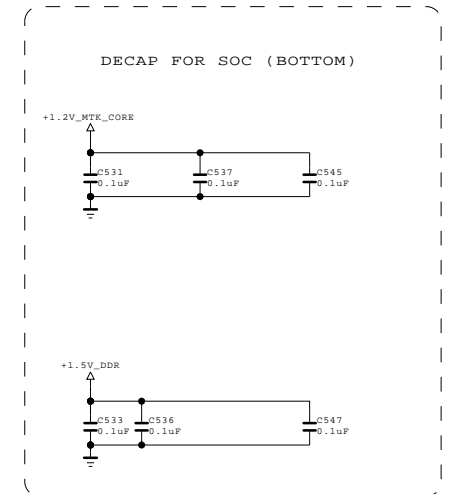
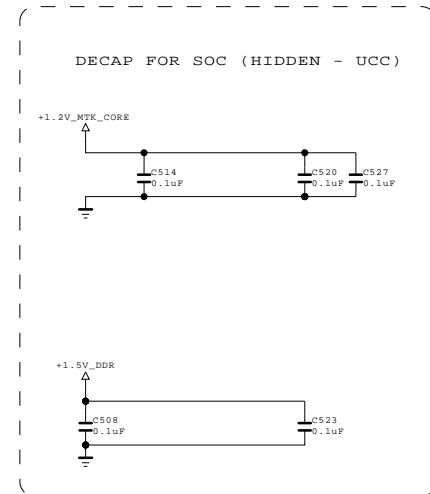
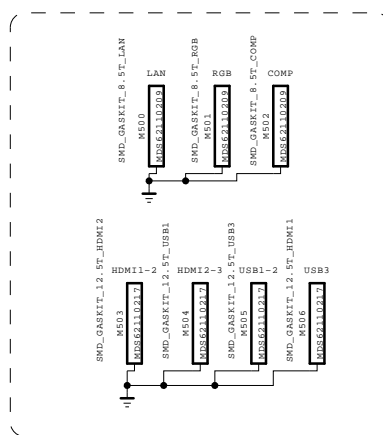

THE SYMBOL MARK OF THIS SCHEMATIC DIAGRAM INCORPORATES SPECIAL FEATURES IMPORTANT FOR PROTECTION FROM X-RADIATION. FILRE AND ELECTRICAL SHOCK HAZARDS, WHEN SERVICING IF IS ESSENTIAL THAT ONLY MANUFACTURES SPECIFIED PARTS BE USED FOR THE CRITICAL COMPONENTS IN THE SYMBOL MARK OF THE SCHEMATIC.

SECRET
LGElectronics



MODEL	MID_MAIN_3	DATE	2011.12.09
BLOCK		SHEET	10

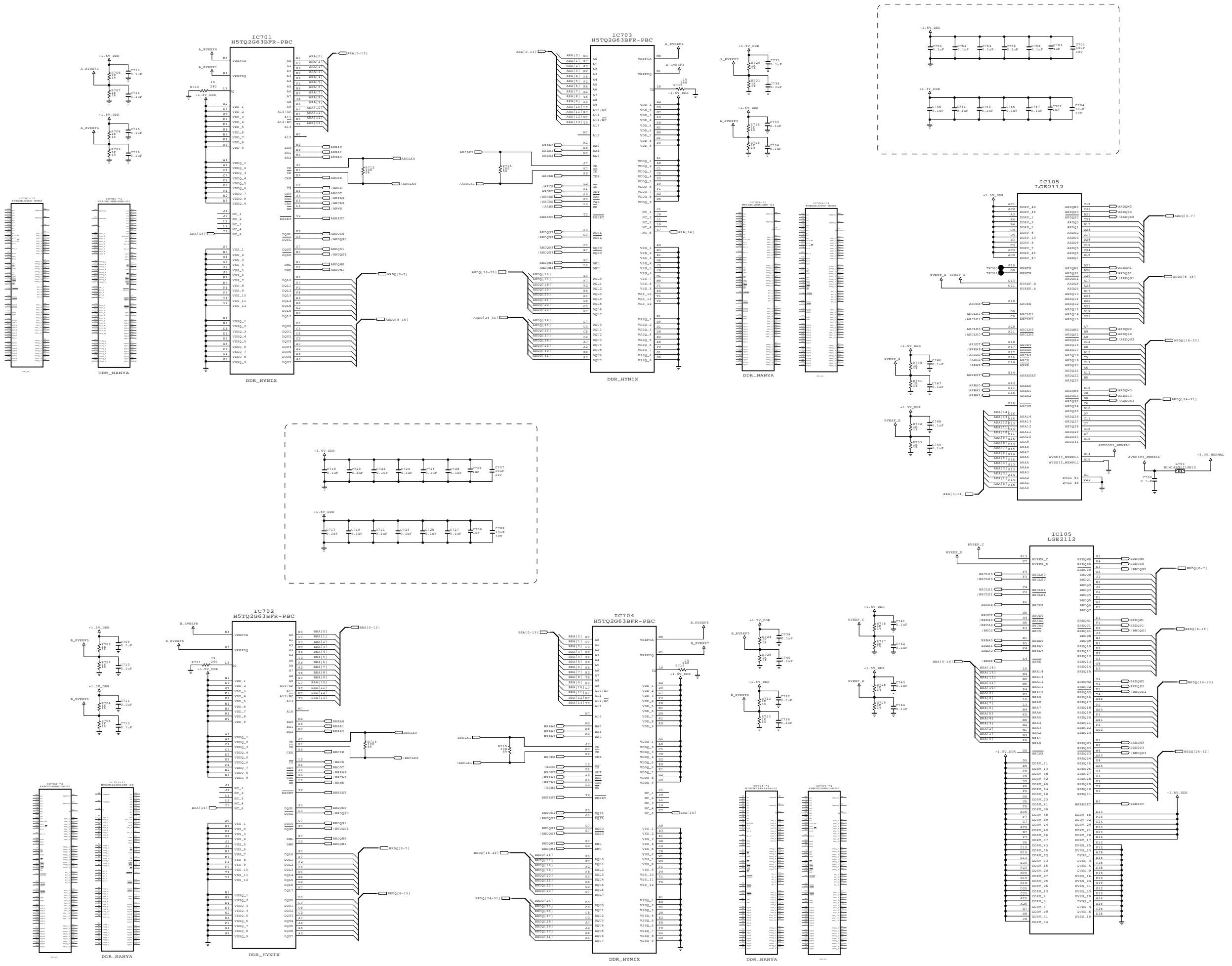

THE SYMBOL MARK OF THIS SCHEMATIC DIAGRAM INCORPORATES SPECIAL FEATURES IMPORTANT FOR PROTECTION FROM X-RADIATION. FILRE AND ELECTRICAL SHOCK HAZARDS, WHEN SERVICING IF IS ESSENTIAL THAT ONLY MANUFACTURERS SPECIFIED PARTS BE USED FOR THE CRITICAL COMPONENTS IN THE SYMBOL MARK OF THE SCHEMATIC.

SECRET
LGElectronics

LG ELECTRONICS

MODEL BLOCK	DDR ONE SIDE	DATE SHEET	2011.12.09 12 /
----------------	--------------	---------------	--------------------

Renesas MICOM

For Debug

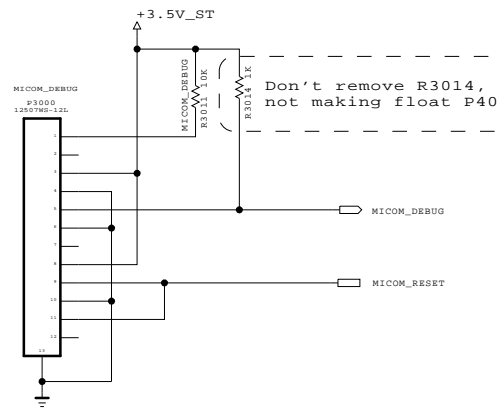

GP4 High/MID Power SEQUENCE

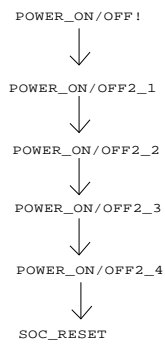

MICOM MODEL OPTION

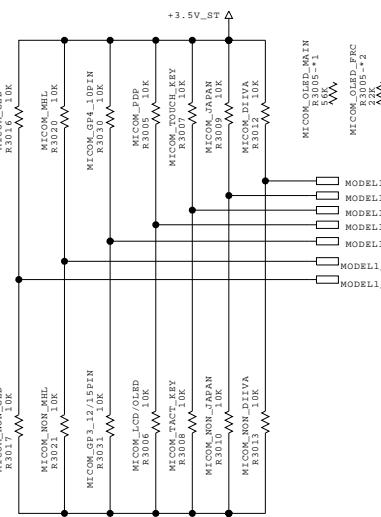

MICOM MODEL OPTION

	0	1	
MODEL_OPT_0	NON DIVA	DIVA	For China
MODEL_OPT_1	NON JAPAN	JAPAN	For JAPAN
MODEL_OPT_2	TACT_KEY	TOUCH_KEY	
MODEL_OPT_3	LCD / OLED	PDP	
MODEL_OPT_4	IR Wafer 12/15Pin GP3_Soft touch	IR Wafer 10Pin (GP4_TOOL)	For Sample Set
MODEL_OPT_5	NON_MHL	MHL	GP4_HIGH
MODEL_OPT_6	NON_GED	GED	

Eye Sensor Option

	0	1	
MODEL_OPT_4			
MODEL_OPT_2			
0	N/A	MC8101_ABOV (TACT_KEY)	
1	CM3231_CAPELLA (GP3 Soft touch)	CM3231_CAPELLA (GP4 Soft touch)	

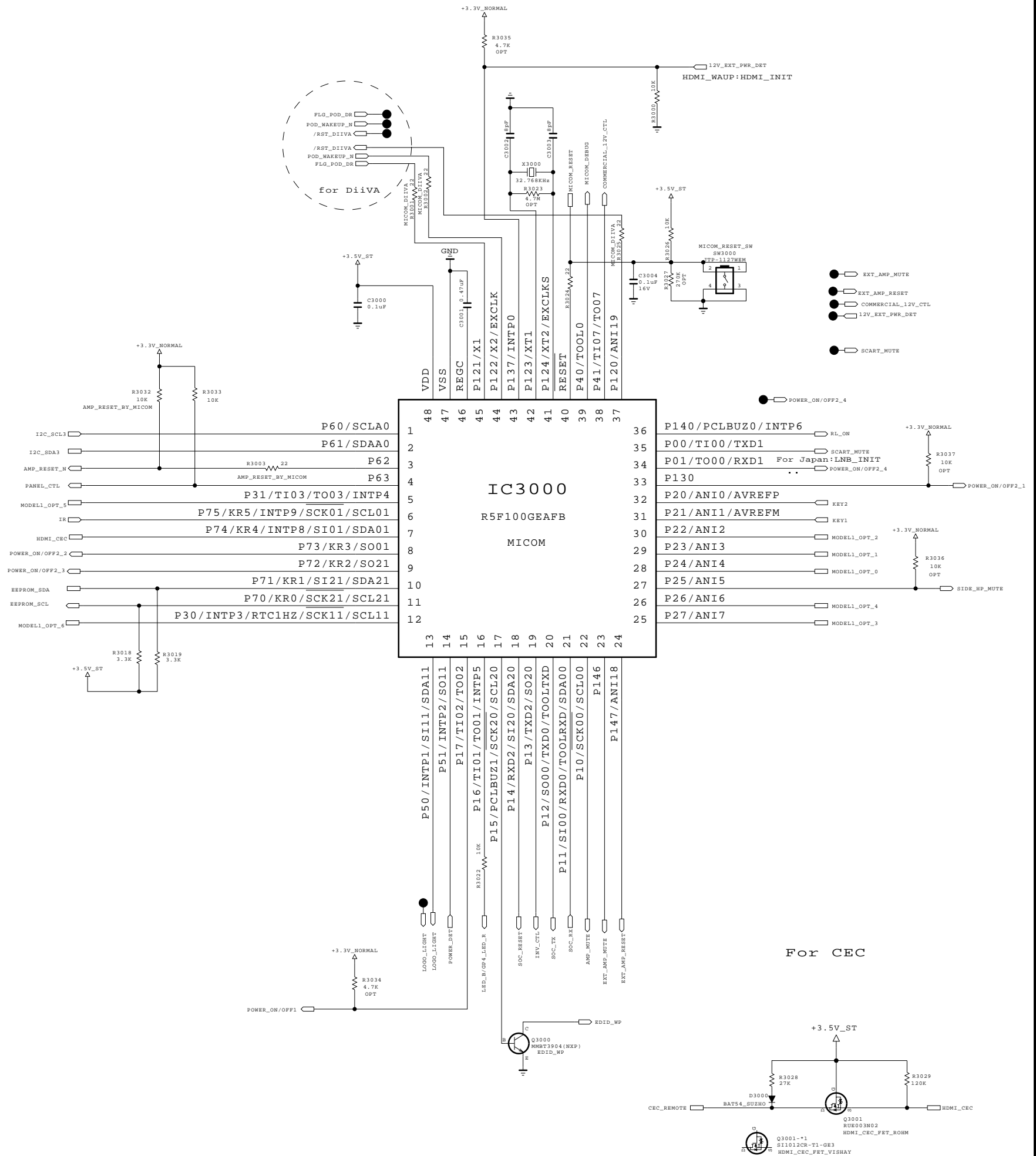

For CEC

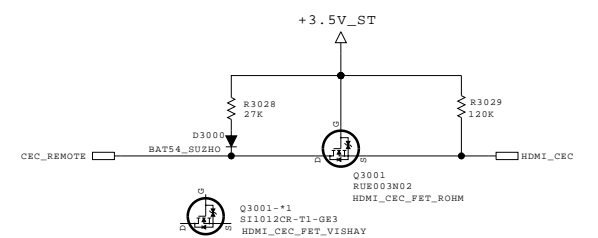

THE SYMBOL MARK OF THIS SCHEMATIC DIAGRAM INCORPORATES SPECIAL FEATURES IMPORTANT FOR PROTECTION FROM X-RADIATION. FILRE AND ELECTRICAL SHOCK HAZARDS, WHEN SERVICING IF IS ESSENTIAL THAT ONLY MANUFACTURES SPECIFIED PARTS BE USED FOR THE CRITICAL COMPONENTS IN THE SYMBOL MARK OF THE SCHEMATIC.

SECRET
LGElectronics

LG ELECTRONICS

MODEL	DATE	2011.12.12
BLOCK	SHEET	30

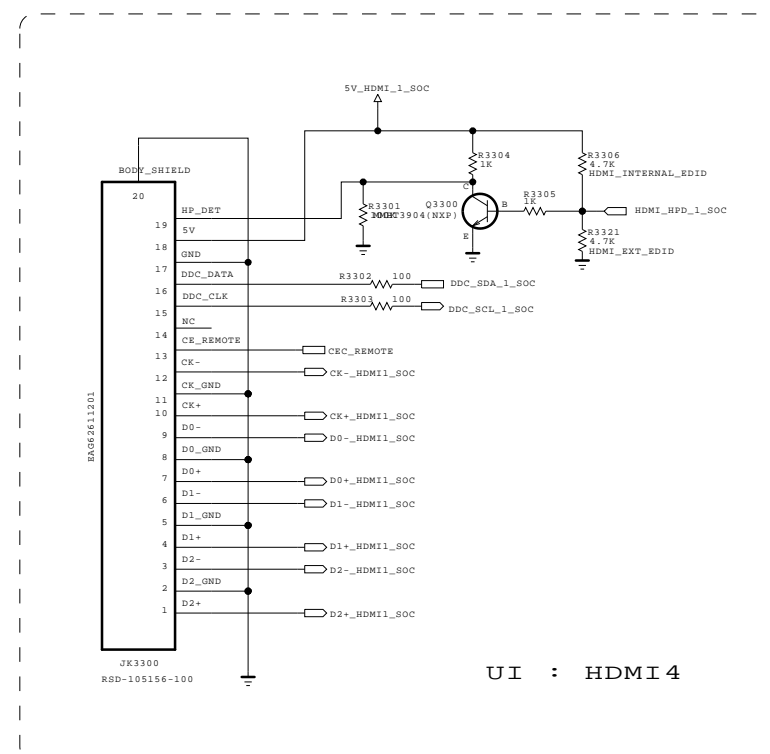
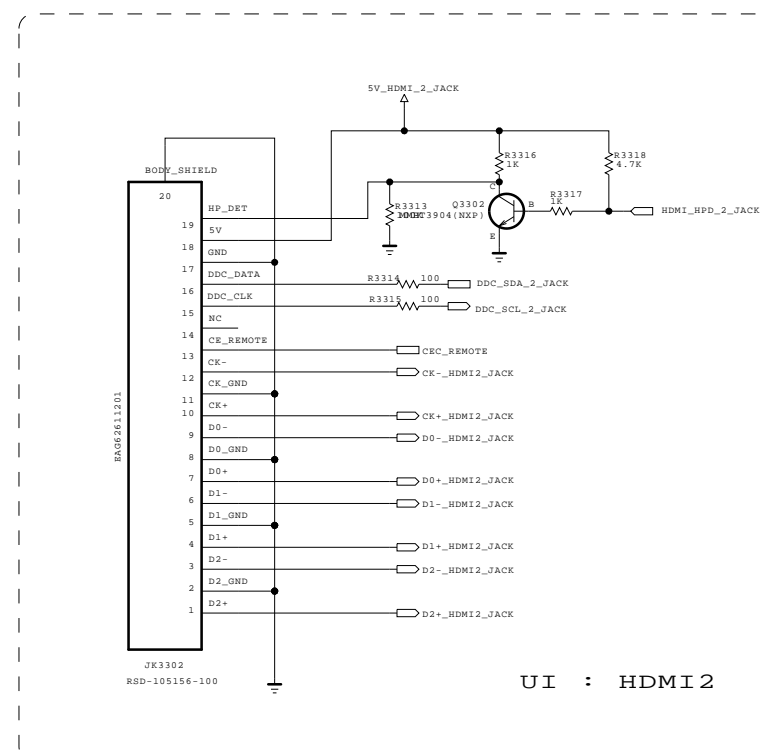
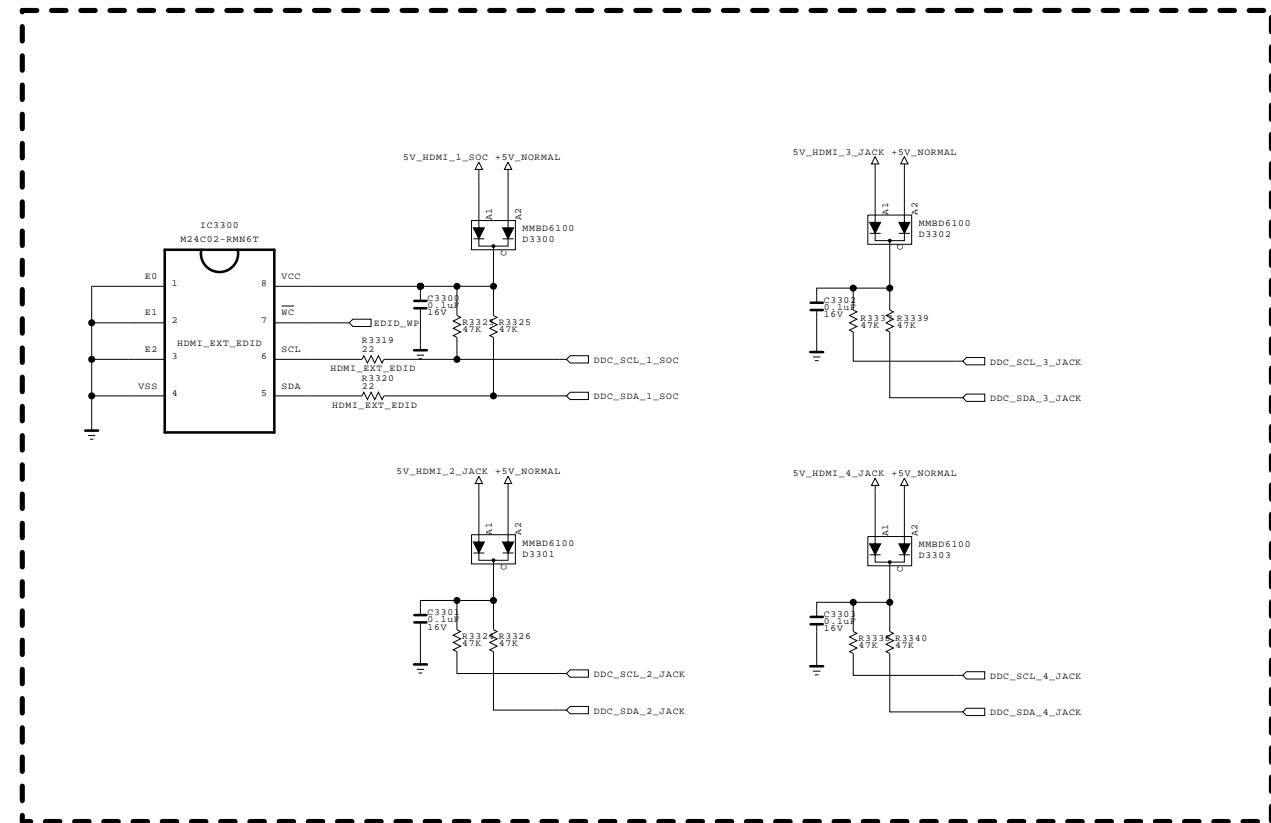
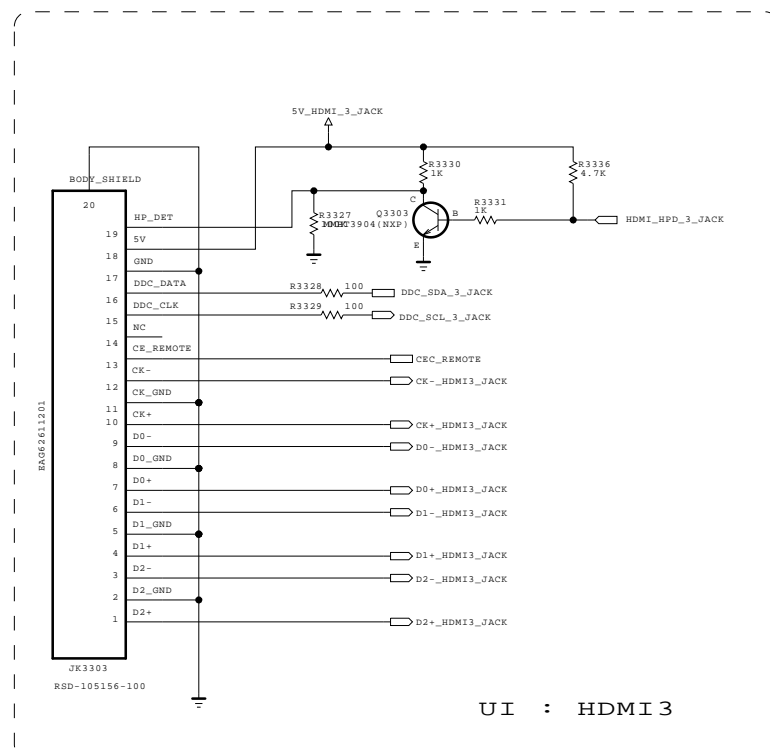
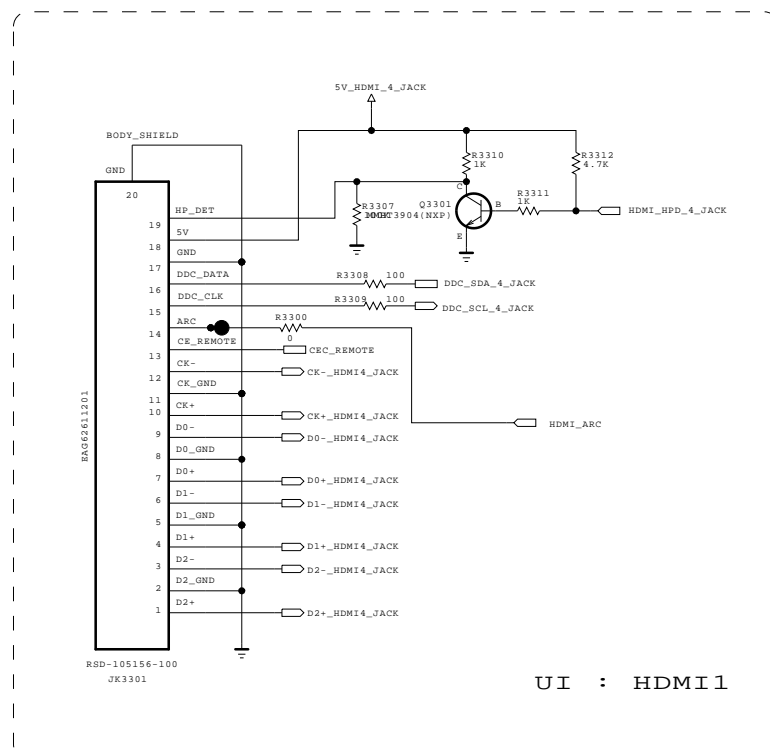

THE SYMBOL MARK OF THIS SCHEMATIC DIAGRAM INCORPORATES SPECIAL FEATURES IMPORTANT FOR PROTECTION FROM X-RADIATION. FILRE AND ELECTRICAL SHOCK HAZARDS, WHEN SERVICING IF IS ESSENTIAL THAT ONLY MANUFACTURES SPECIFIED PARTS BE USED FOR THE CRITICAL COMPONENTS IN THE SYMBOL MARK OF THE SCHEMATIC.

SECRET
LGElectronics



MODEL	HDMI 4	DATE	2011.10.29
BLOCK		SHEET	33

RGB / PC AUDIO / SPDIF

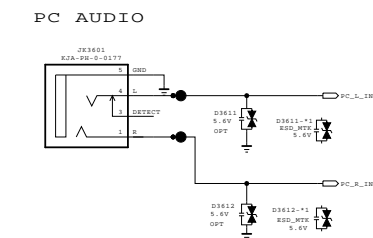
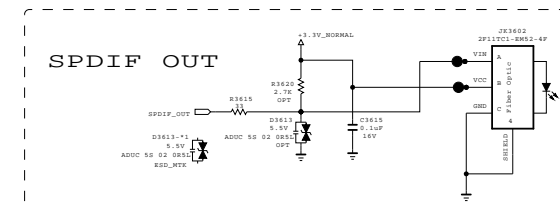
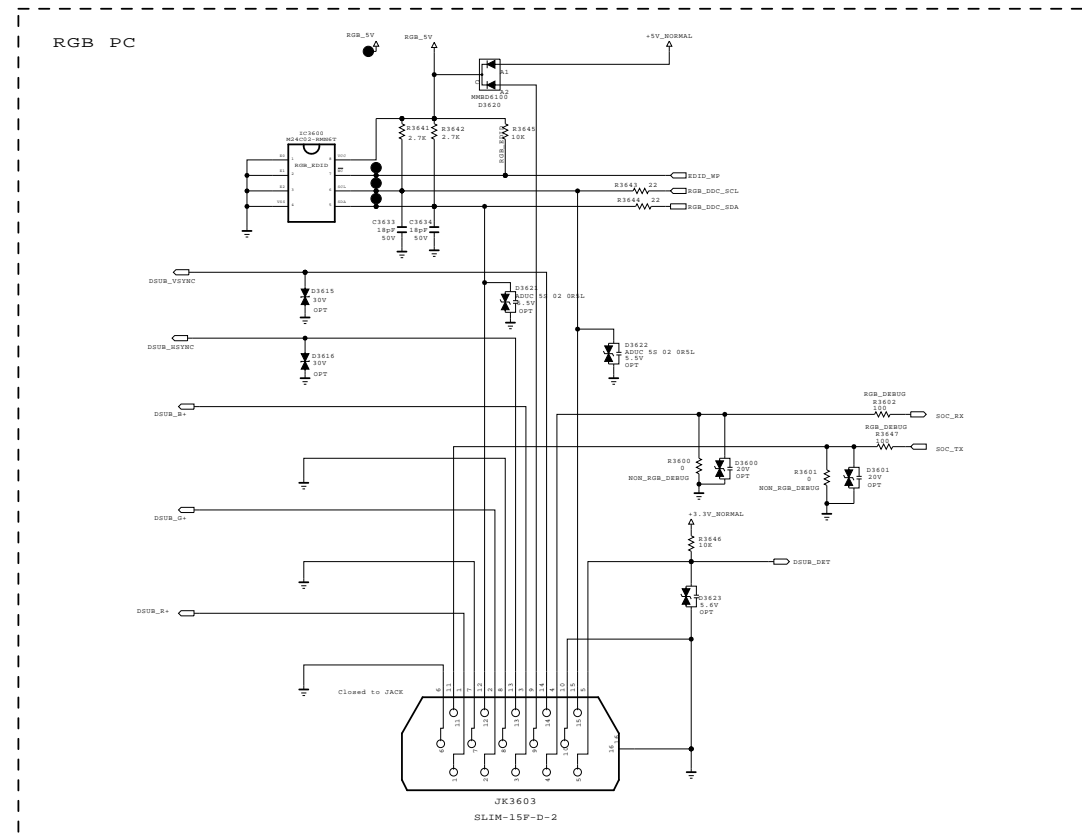

THE SYMBOL MARK OF THIS SCHEMATIC DIAGRAM INCORPORATES SPECIAL FEATURES IMPORTANT FOR PROTECTION FROM X-RADIATION. FILRE AND ELECTRICAL SHOCK HAZARDS, WHEN SERVICING IF IS ESSENTIAL THAT ONLY MANUFACTURES SPECIFIED PARTS BE USED FOR THE CRITICAL COMPONENTS IN THE SYMBOL MARK OF THE SCHEMATIC.

SECRET
LGElectronics

LG ELECTRONICS

MODEL	JACK HIGH / MID	DATE	2011.11.21
BLOCK		SHEET	36 /

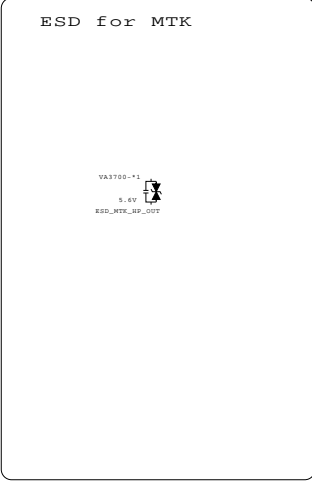
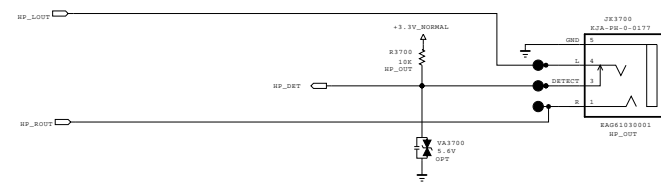

THE SYMBOL MARK OF THIS SCHEMATIC DIAGRAM INCORPORATES SPECIAL FEATURES IMPORTANT FOR PROTECTION FROM X-RADIATION. FILRE AND ELECTRICAL SHOCK HAZARDS, WHEN SERVICING IF IS ESSENTIAL THAT ONLY MANUFACTURES SPECIFIED PARTS BE USED FOR THE CRITICAL COMPONENTS IN THE SYMBOL MARK OF THE SCHEMATIC.

SECRET
LGElectronics



MODEL	JACK_COMMON	DATE	2011.11.21
BLOCK		SHEET	37 /

RS232C

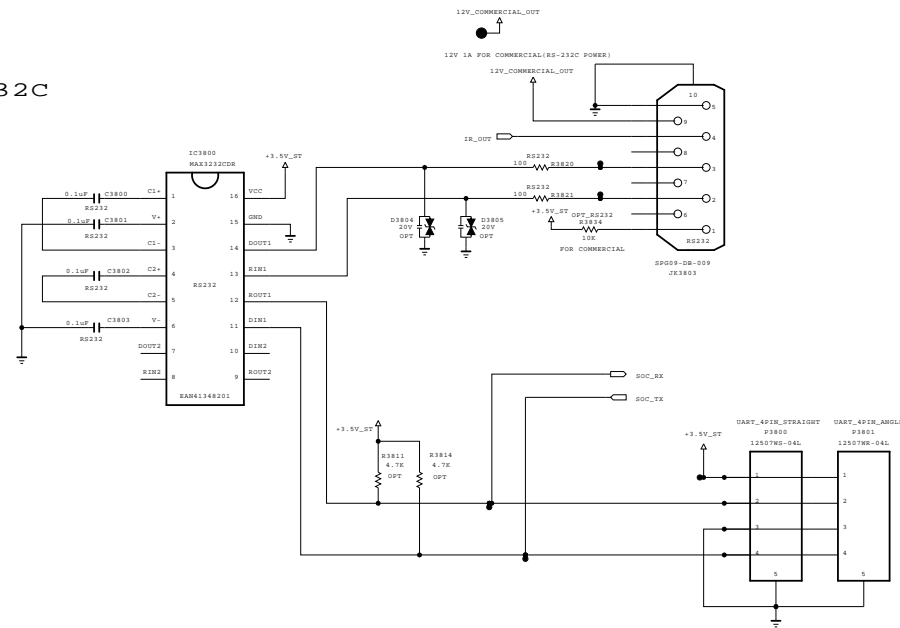

CVBS 1 PHONE JACK

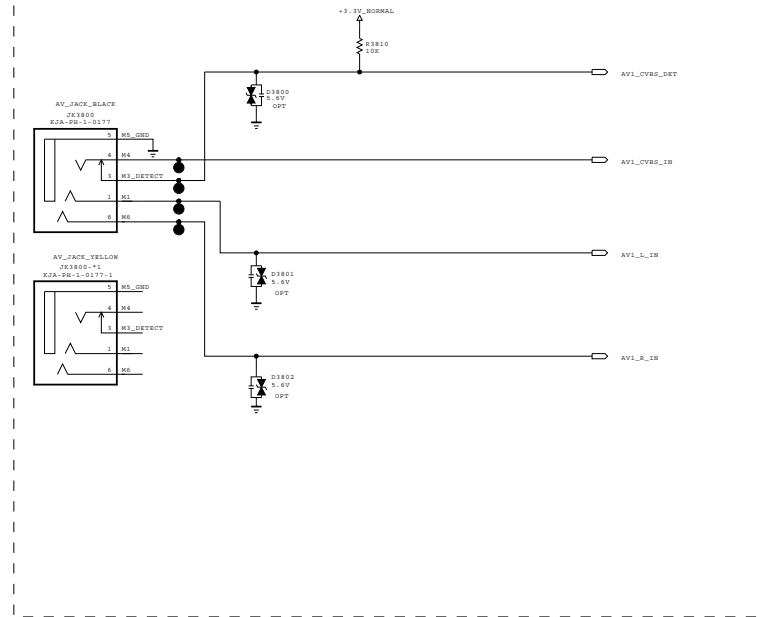

COMPONENT 1 PHONE JACK

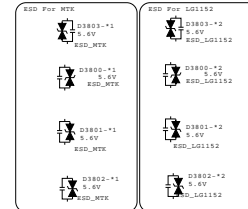
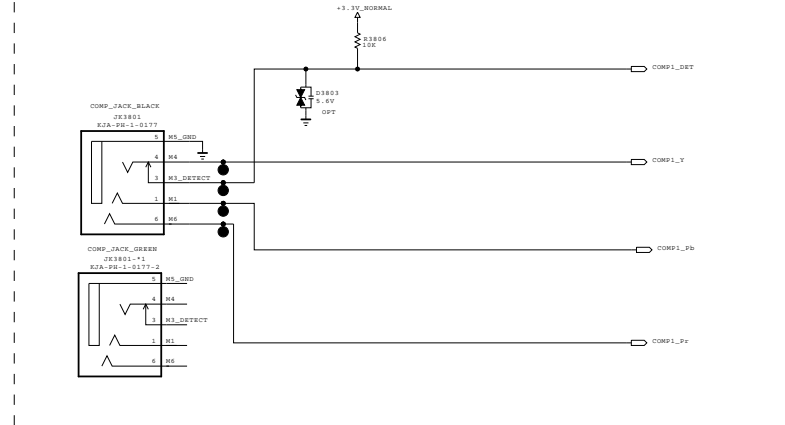

THE SYMBOL MARK OF THIS SCHEMATIC DIAGRAM INCORPORATES SPECIAL FEATURES IMPORTANT FOR PROTECTION FROM X-RADIATION. FILRE AND ELECTRICAL SHOCK HAZARDS, WHEN SERVICING IF IS ESSENTIAL THAT ONLY MANUFACTURES SPECIFIED PARTS BE USED FOR THE CRITICAL COMPONENTS IN THE SYMBOL MARK OF THE SCHEMATIC.

SECRET
LGElectronics

LG ELECTRONICS

MODEL	JACK_COMMON	DATE	2011.11.21
BLOCK		SHEET	38 /

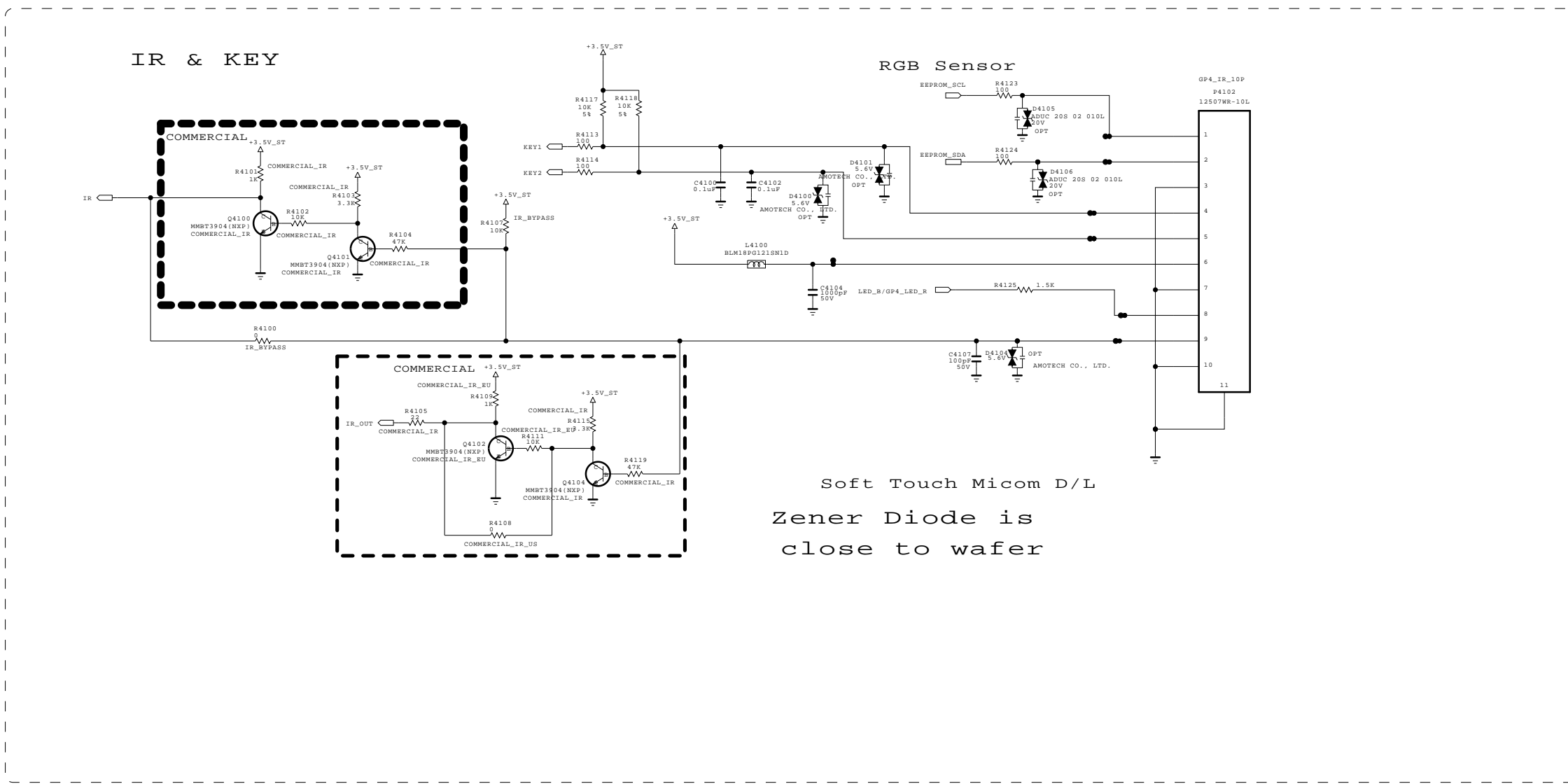

Soft Touch Micom D/L
Zener Diode is
close to wafer

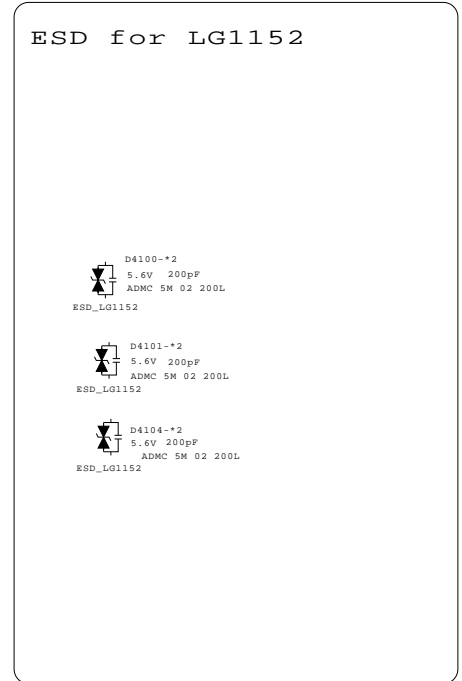
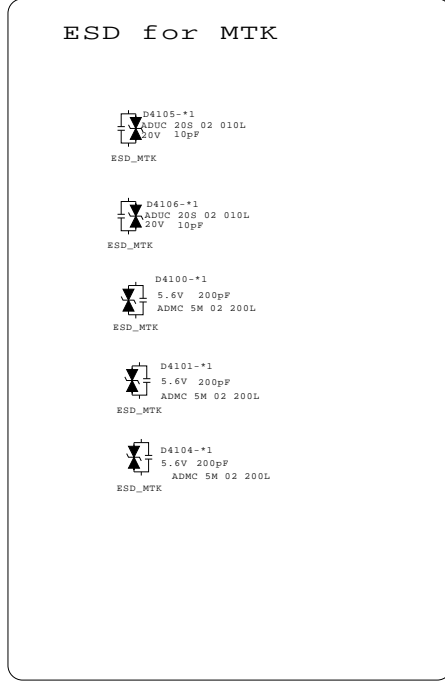

THE SYMBOL MARK OF THIS SCHEMATIC DIAGRAM INCORPORATES SPECIAL FEATURES IMPORTANT FOR PROTECTION FROM X-RADIATION. FILRE AND ELECTRICAL SHOCK HAZARDS, WHEN SERVICING IF IS ESSENTIAL THAT ONLY MANUFACTURES SPECIFIED PARTS BE USED FOR THE CRITICAL COMPONENTS IN THE SYMBOL MARK OF THE SCHEMATIC.

SECRET
LGElectronics



MODEL	IR / KEY	DATE	2011.11.21
BLOCK		SHEET	41 /

+5V_USB FOR USB1

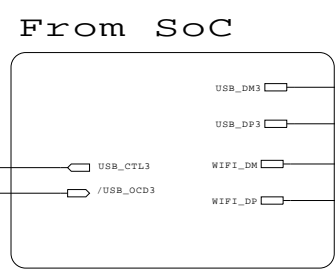
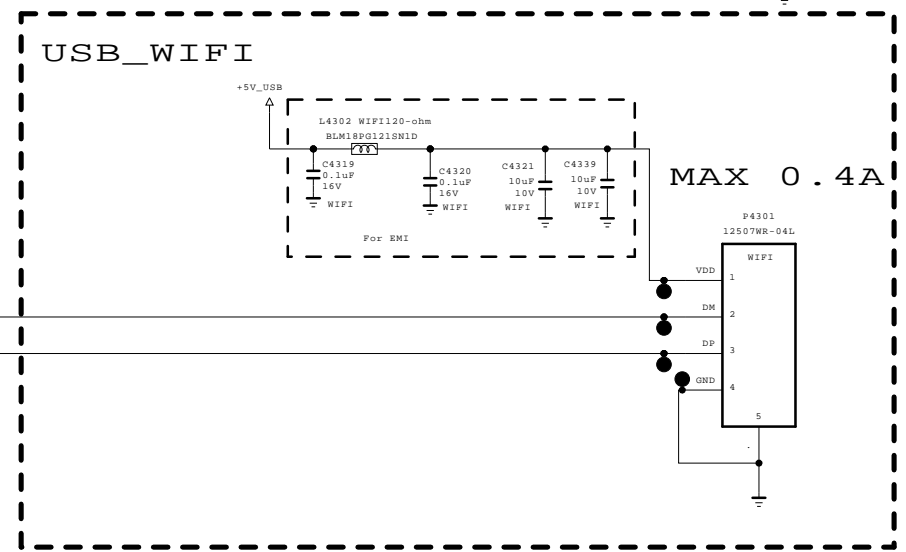
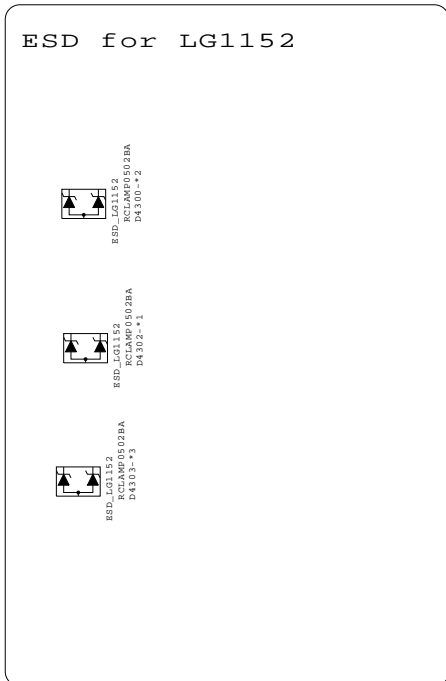
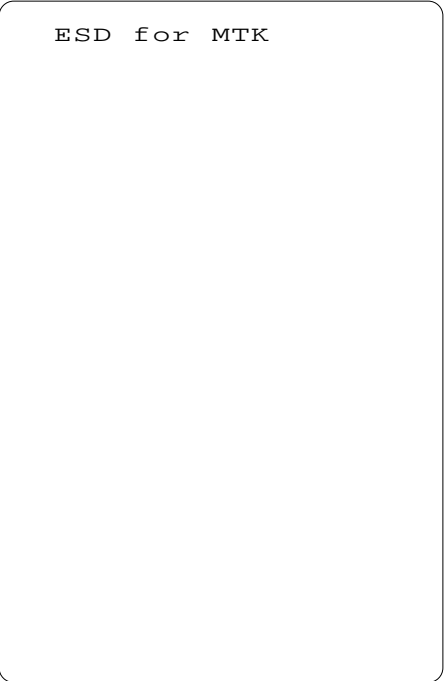
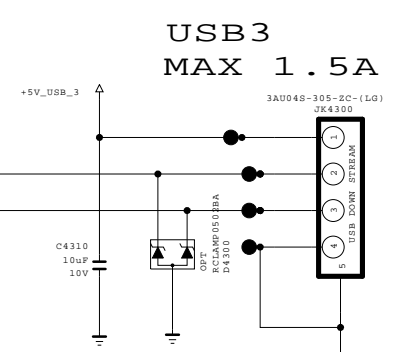
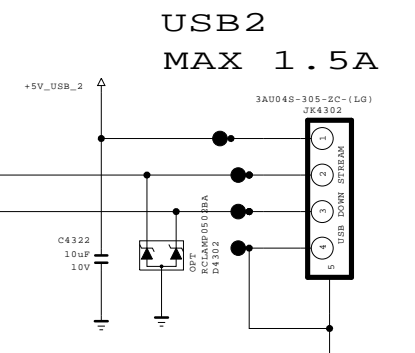
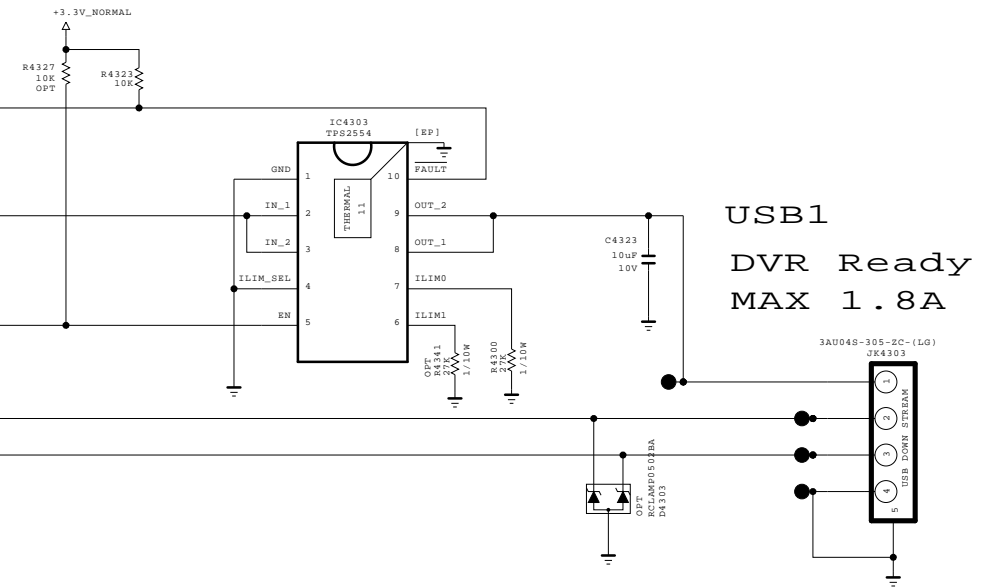
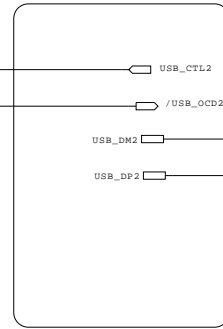
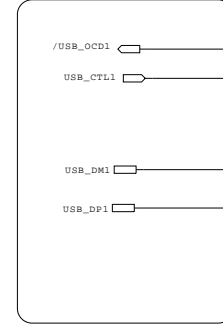
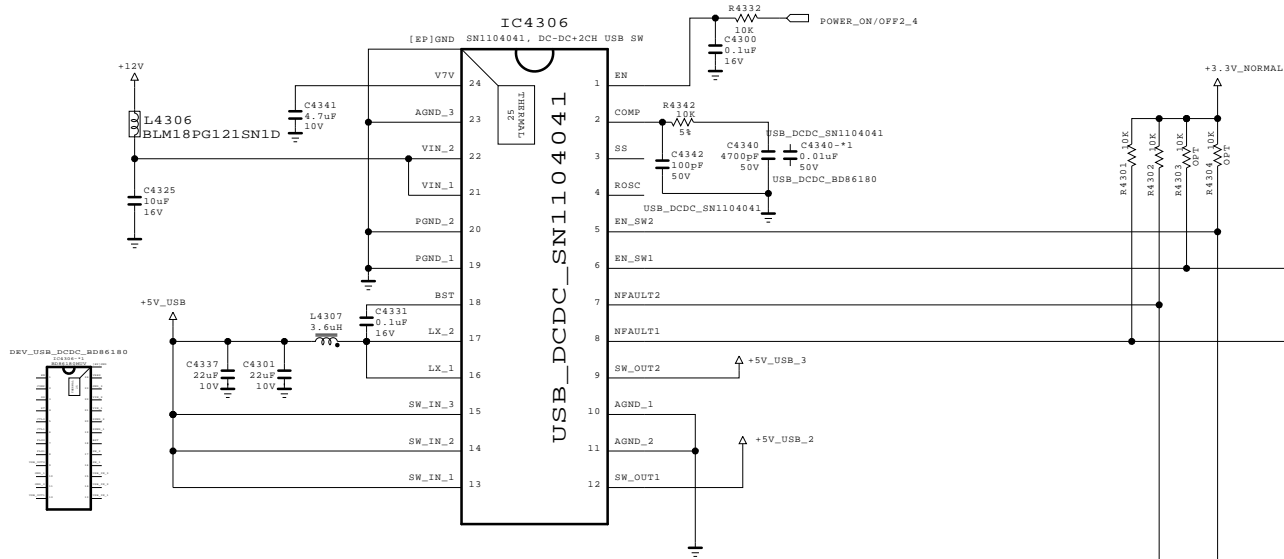
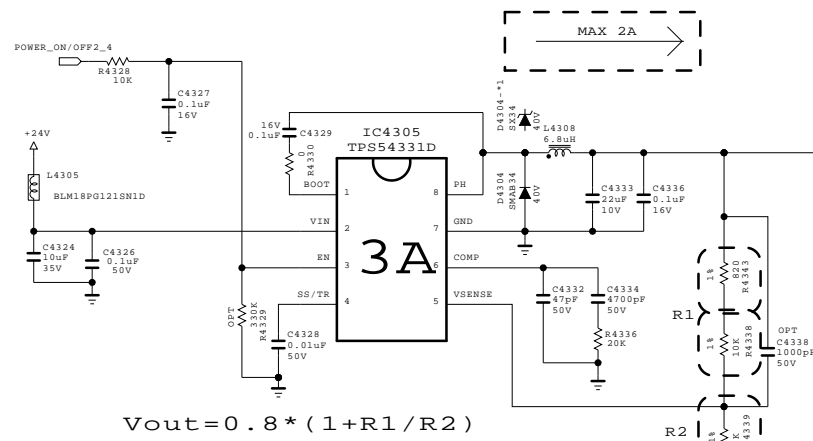

THE SYMBOL MARK OF THIS SCHEMATIC DIAGRAM INCORPORATES SPECIAL FEATURES IMPORTANT FOR PROTECTION FROM X-RADIATION. FILRE AND ELECTRICAL SHOCK HAZARDS, WHEN SERVICING IF IS ESSENTIAL THAT ONLY MANUFACTURES SPECIFIED PARTS BE USED FOR THE CRITICAL COMPONENTS IN THE SYMBOL MARK OF THE SCHEMATIC.

SECRET
LGElectronics



MODEL	USB3_HUB_WiFi	DATE	2011.10.26
BLOCK		SHEET	43

ZigBee_Radio Pulse M_REMOTE OPTION

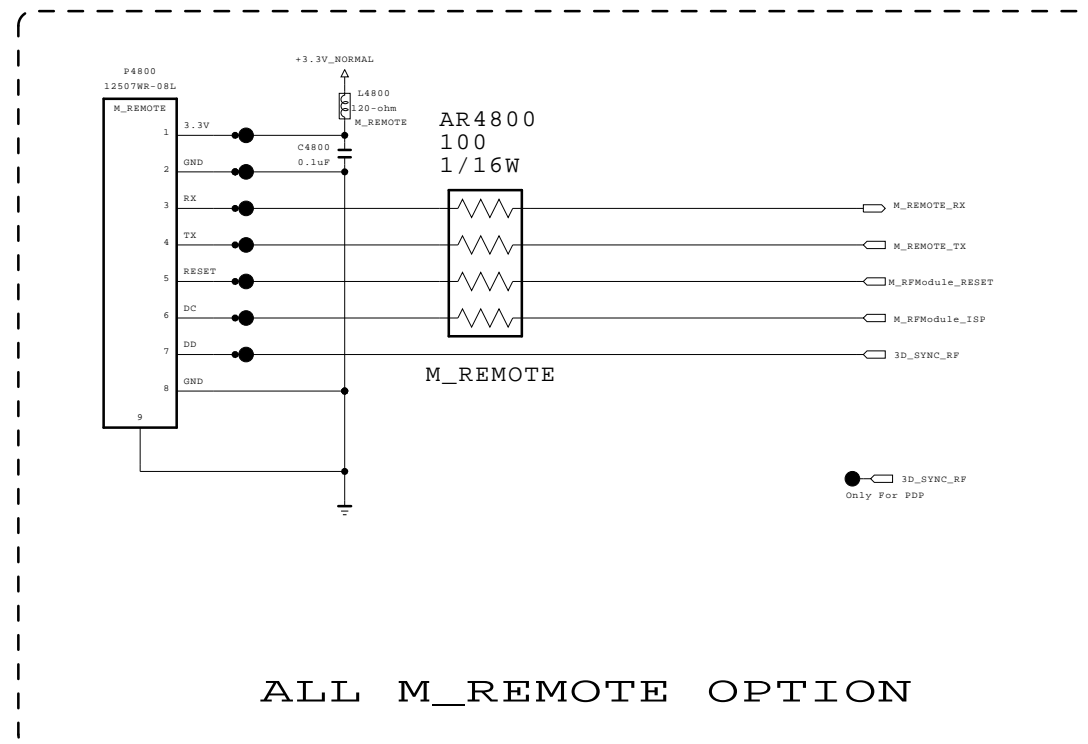

THE SYMBOL MARK OF THIS SCHEMATIC DIAGRAM INCORPORATES SPECIAL FEATURES IMPORTANT FOR PROTECTION FROM X-RADIATION. FILRE AND ELECTRICAL SHOCK HAZARDS, WHEN SERVICING IF IS ESSENTIAL THAT ONLY MANUFACTURES SPECIFIED PARTS BE USED FOR THE CRITICAL COMPONENTS IN THE SYMBOL MARK OF THE SCHEMATIC.

SECRET
LGElectronics



MODEL	MOTION REMOTE	DATE	2011.11.21
BLOCK		SHEET	48 /

Ethernet Block

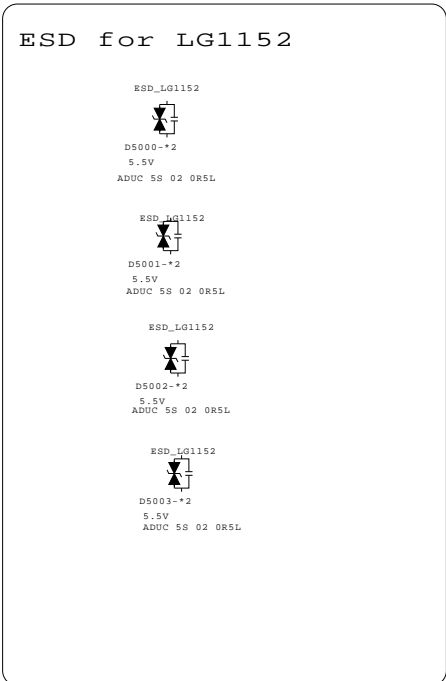
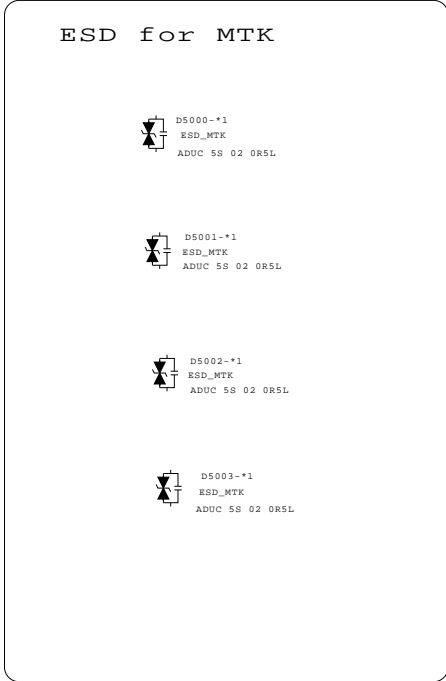
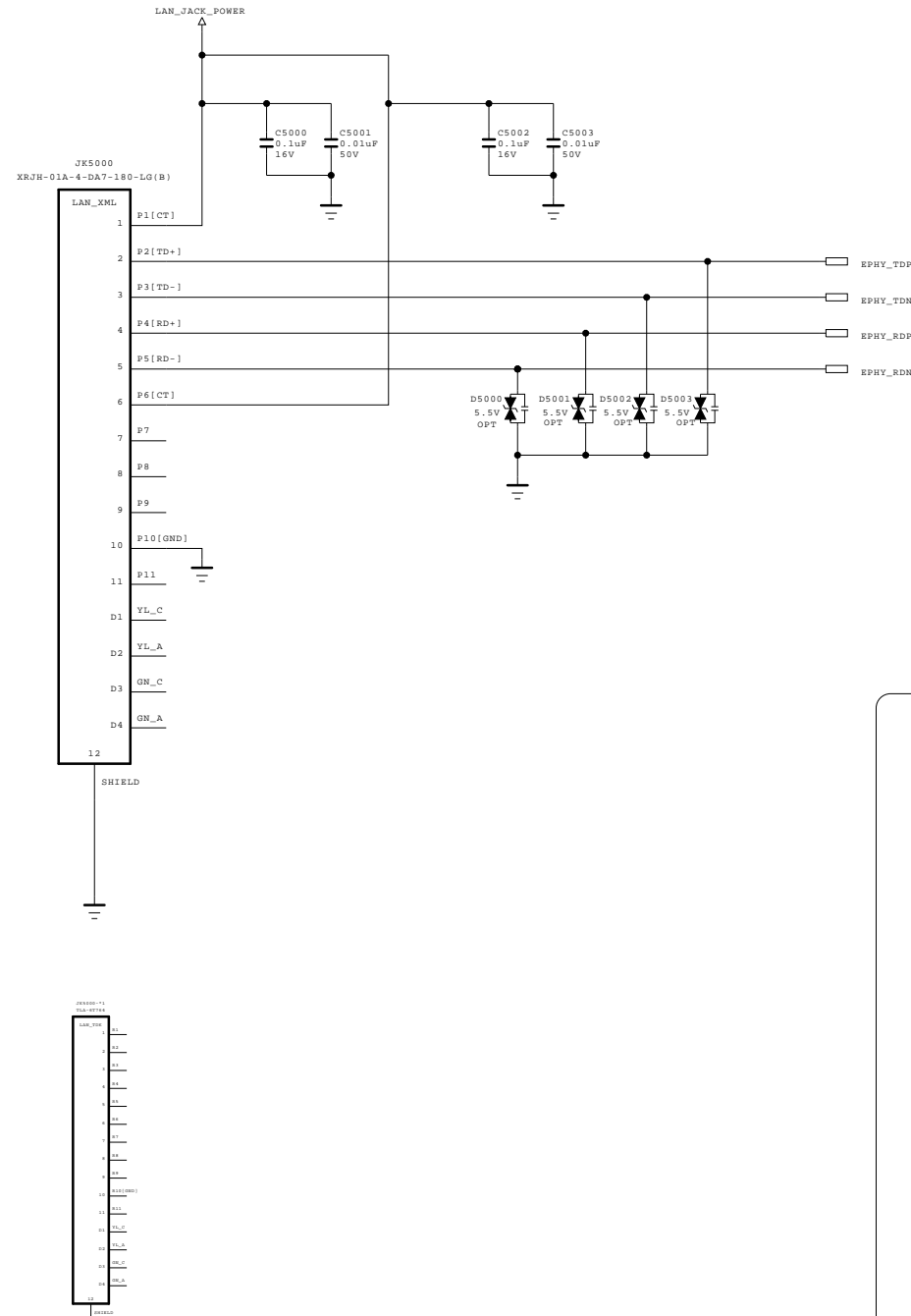

THE SYMBOL MARK OF THIS SCHEMATIC DIAGRAM INCORPORATES SPECIAL FEATURES IMPORTANT FOR PROTECTION FROM X-RADIATION. FILRE AND ELECTRICAL SHOCK HAZARDS, WHEN SERVICING IF IS ESSENTIAL THAT ONLY MANUFACTURES SPECIFIED PARTS BE USED FOR THE CRITICAL COMPONENTS IN THE SYMBOL MARK OF THE SCHEMATIC.

SECRET
LGElectronics



MODEL	LAN_VERTICAL	DATE	2011.12.09
BLOCK		SHEET	50

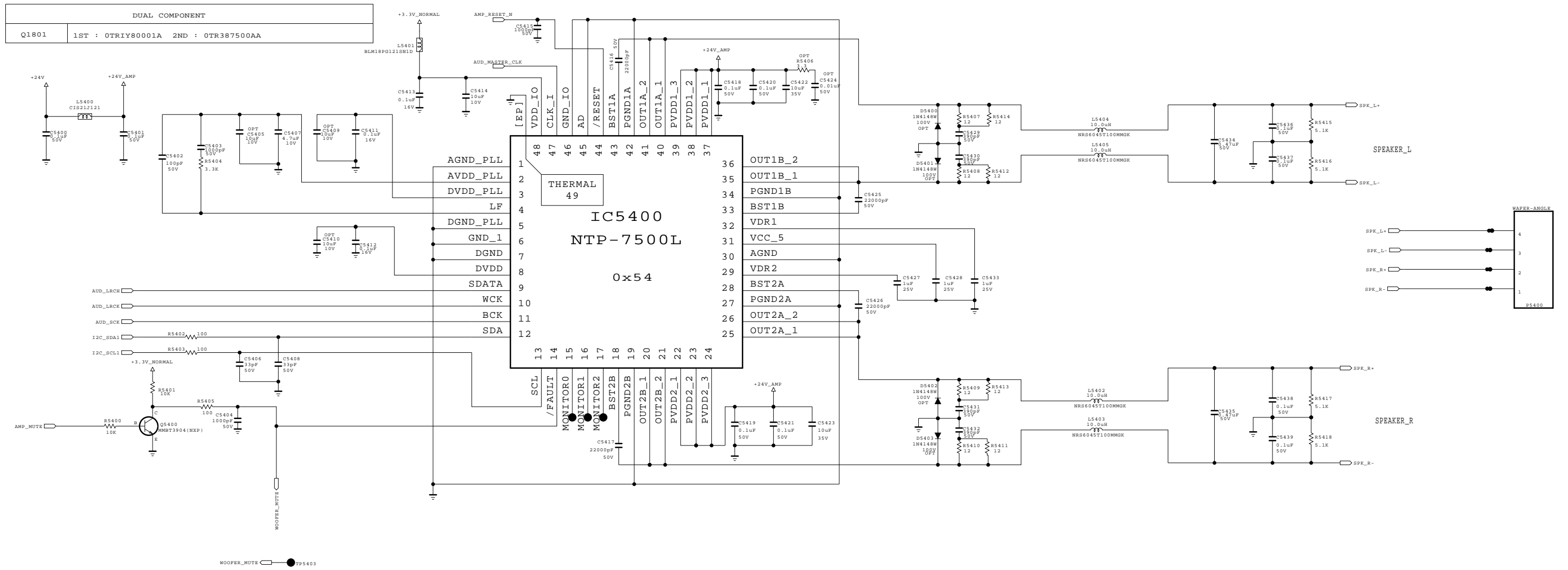

THE SYMBOL MARK OF THIS SCHEMATIC DIAGRAM INCORPORATES SPECIAL FEATURES IMPORTANT FOR PROTECTION FROM X-RADIATION. FILRE AND ELECTRICAL SHOCK HAZARDS, WHEN SERVICING IF IS ESSENTIAL THAT ONLY MANUFACTURES SPECIFIED PARTS BE USED FOR THE CRITICAL COMPONENTS IN THE SYMBOL MARK OF THE SCHEMATIC.



SECRET
LGElectronics

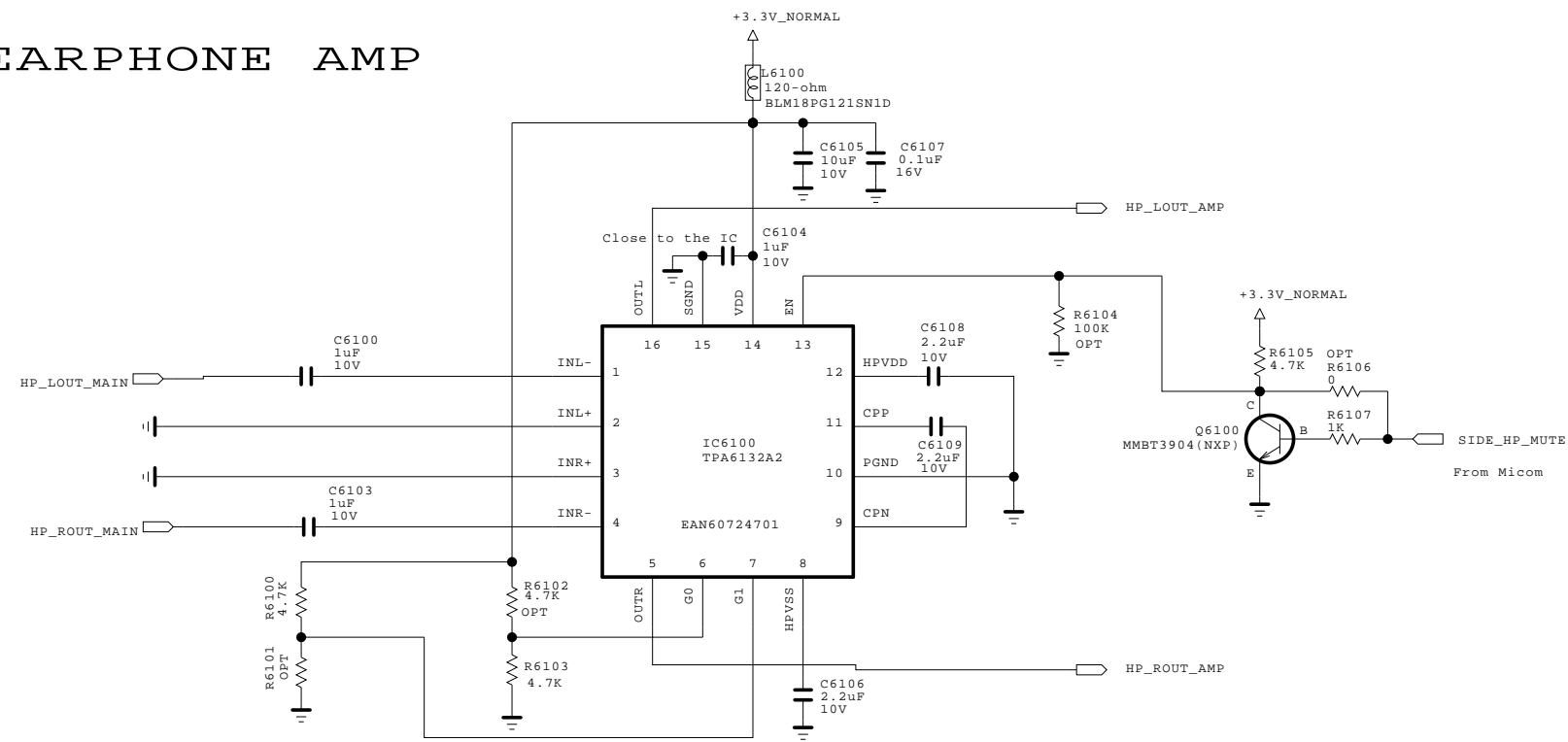

MODEL	AMP_NEO	DATE	2011.11.21
BLOCK		SHEET	54

EARPHONE AMP



THE  SYMBOL MARK OF THIS SCHEMATIC DIAGRAM INCORPORATES SPECIAL FEATURES IMPORTANT FOR PROTECTION FROM X-RADIATION. FILRE AND ELECTRICAL SHOCK HAZARDS, WHEN SERVICING IF IS ESSENTIAL THAT ONLY MANUFACTURES SPECIFIED PARTS BE USED FOR THE CRITICAL COMPONENTS IN THE  SYMBOL MARK OF THE SCHEMATIC.

SECRET	 LG ELECTRONICS
LGElectronics	

MODEL	HEADPHONE AMP	DATE	2011.09.29
BLOCK		SHEET	61 /

T/C/S & H/NIM & T2/C TUNER (EU & CHINA)

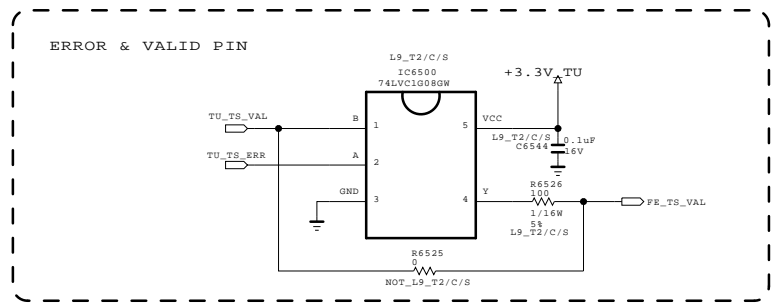
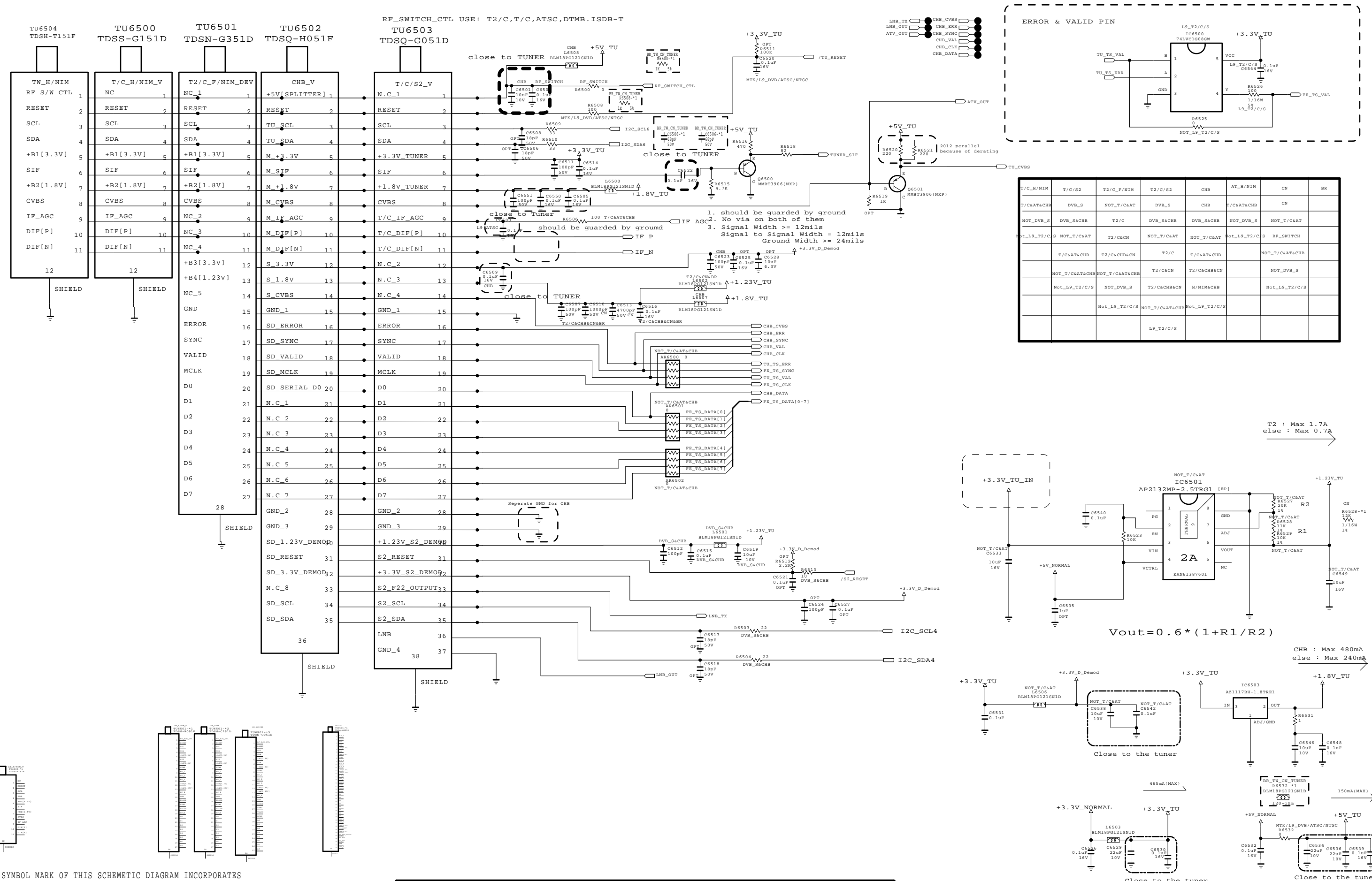

T/C/H/NIM	T/C/S2	T2/C_F/NIM_DEV	T2/C/S2	CHB	AT_H/NIM	CN	BR
T/C&AT&CHB	DVB_S	NOT_T/C&AT	DVB_S	CHB	T/C&AT&CHB	CN	
NOT_DVB_S	DVB_S&CHB	T2/C	DVB_S&CHB	DVB_S&CHB	NOT_DVB_S	NOT_T/C&AT	
NOT_L9_T2/C/S	NOT_T/C&AT	T2/C&CHB	NOT_T/C&AT	NOT_T/C&AT	NOT_L9_T2/C/S	RF_SWITCH	
	T/C&AT&CHB	T2/C&CHB&CN	T2/C	T/C&AT&CHB		NOT_T/C&AT&CHB	
	NOT_T/C&AT&CHB	NOT_T/C&AT&CHB	T2/C&CN	T2/C&CHB&CN		NOT_DVB_S	
	Not_L9_T2/C/S	NOT_DVB_S	T2/C&CHB&CN	H/NIM&CHB		Not_L9_T2/C/S	
		Not_L9_T2/C/S	NOT_T/C&AT&CHB	Not_L9_T2/C/S			
				L9_T2/C/S			

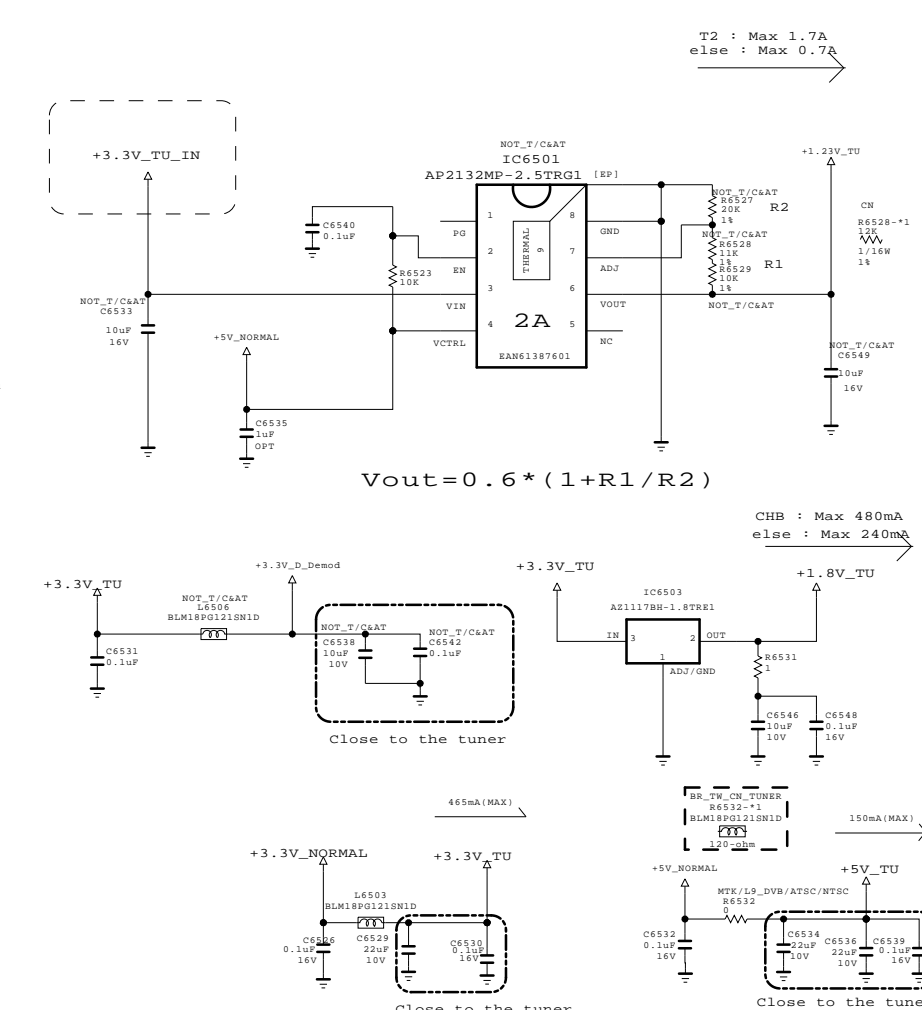

THE Δ SYMBOL MARK OF THIS SCHEMATIC DIAGRAM INCORPORATES SPECIAL FEATURES IMPORTANT FOR PROTECTION FROM X-RADIATION. FILRE AND ELECTRICAL SHOCK HAZARDS, WHEN SERVICING IF IS ESSENTIAL THAT ONLY MANUFACTURERS SPECIFIED PARTS BE USED FOR THE CRITICAL COMPONENTS IN THE Δ SYMBOL MARK OF THE SCHEMATIC.

SECRET
LGElectronics



MODEL	TUNER	DATE	2011.11.21
BLOCK		SHEET	65

FOR COMMERCIAL 12V OUT RS-232C 9 PIN
(OPT:COMMER_EXT_12V)

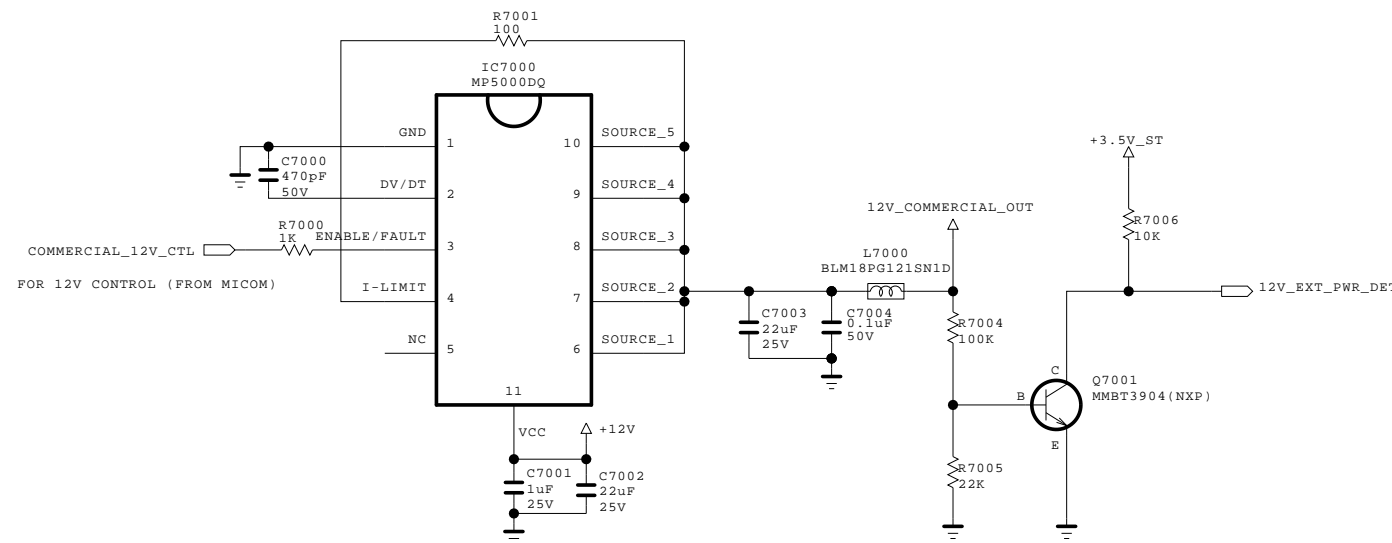

FOR COMMERCIAL AUDIO OUT
(OPT:COMMER_EXT_AMP)

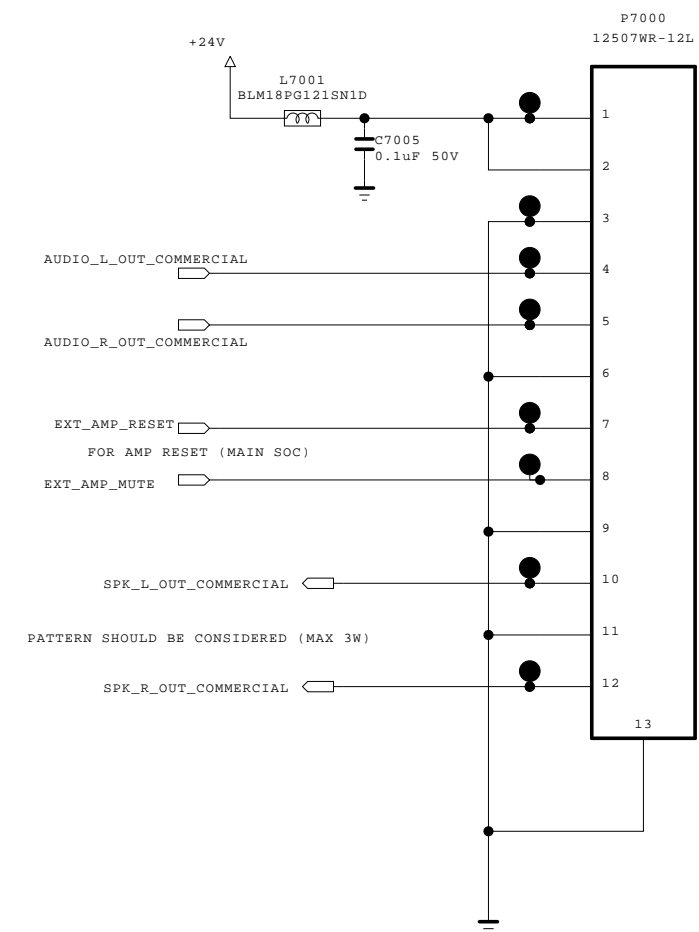

AUDIO OUT JACK
(OPT:COMMER_EXT_AMP)

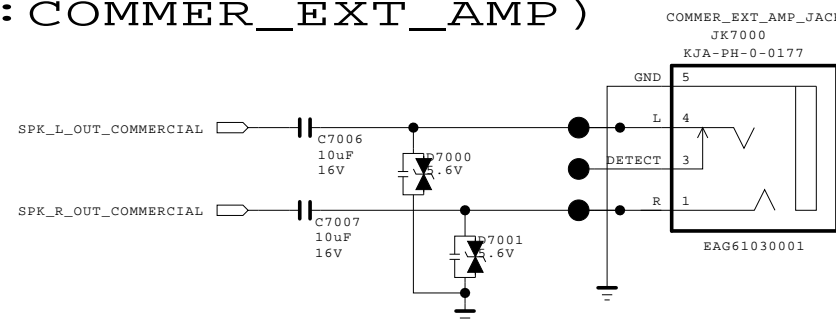

THE SYMBOL MARK OF THIS SCHEMATIC DIAGRAM INCORPORATES SPECIAL FEATURES IMPORTANT FOR PROTECTION FROM X-RADIATION. FILRE AND ELECTRICAL SHOCK HAZARDS, WHEN SERVICING IF IS ESSENTIAL THAT ONLY MANUFACTURES SPECIFIED PARTS BE USED FOR THE CRITICAL COMPONENTS IN THE SYMBOL MARK OF THE SCHEMATIC.

SECRET	
LGElectronics	

MODEL	COMMERCIAL_OPTION	DATE	2011.11.21
BLOCK		SHEET	70 /

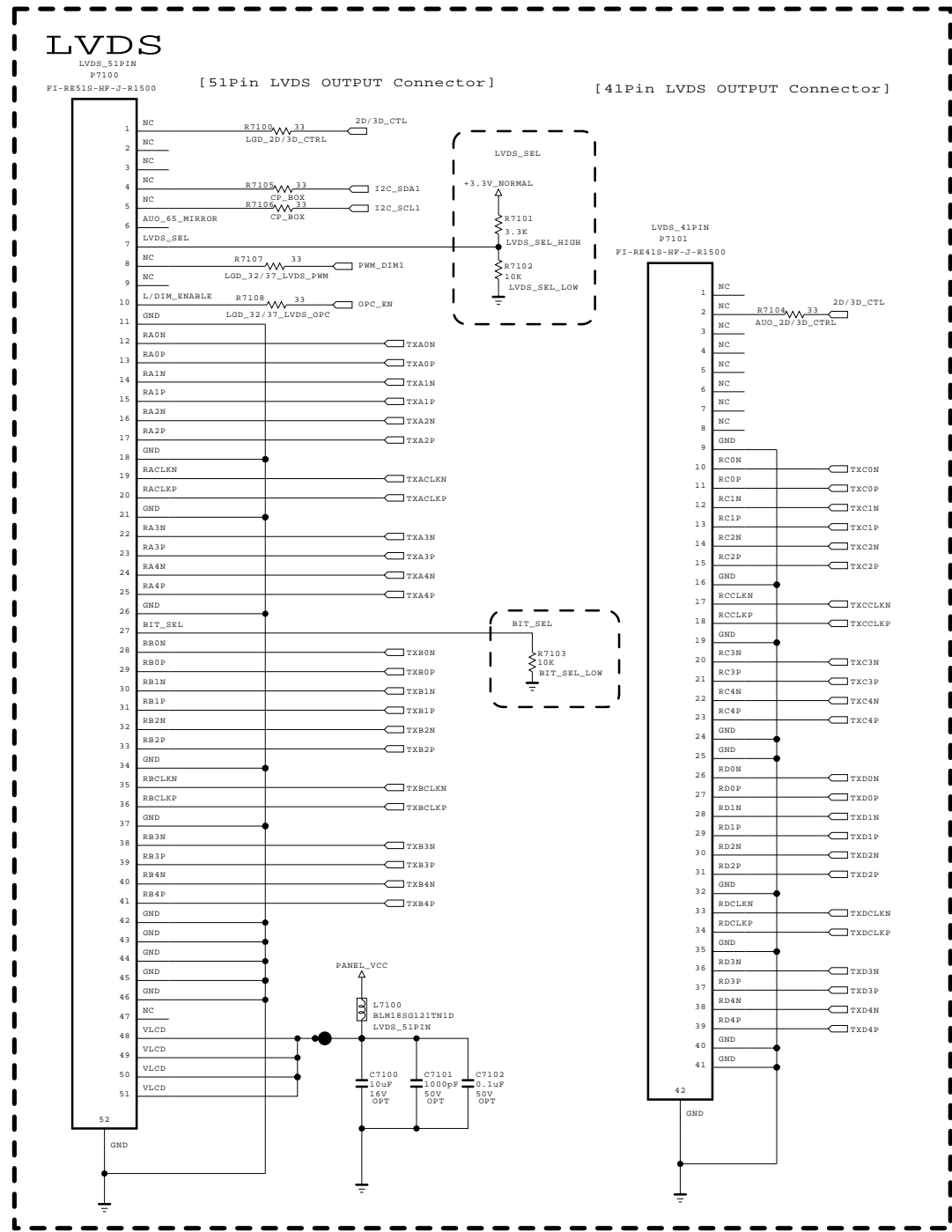

THE SYMBOL MARK OF THIS SCHEMATIC DIAGRAM INCORPORATES SPECIAL FEATURES IMPORTANT FOR PROTECTION FROM X-RADIATION. FILRE AND ELECTRICAL SHOCK HAZARDS, WHEN SERVICING IF IS ESSENTIAL THAT ONLY MANUFACTURES SPECIFIED PARTS BE USED FOR THE CRITICAL COMPONENTS IN THE SYMBOL MARK OF THE SCHEMATIC.

SECRET
LGElectronics



MODEL	LVDS_HIGH_MID	DATE	2011.08.11
BLOCK		SHEET	71

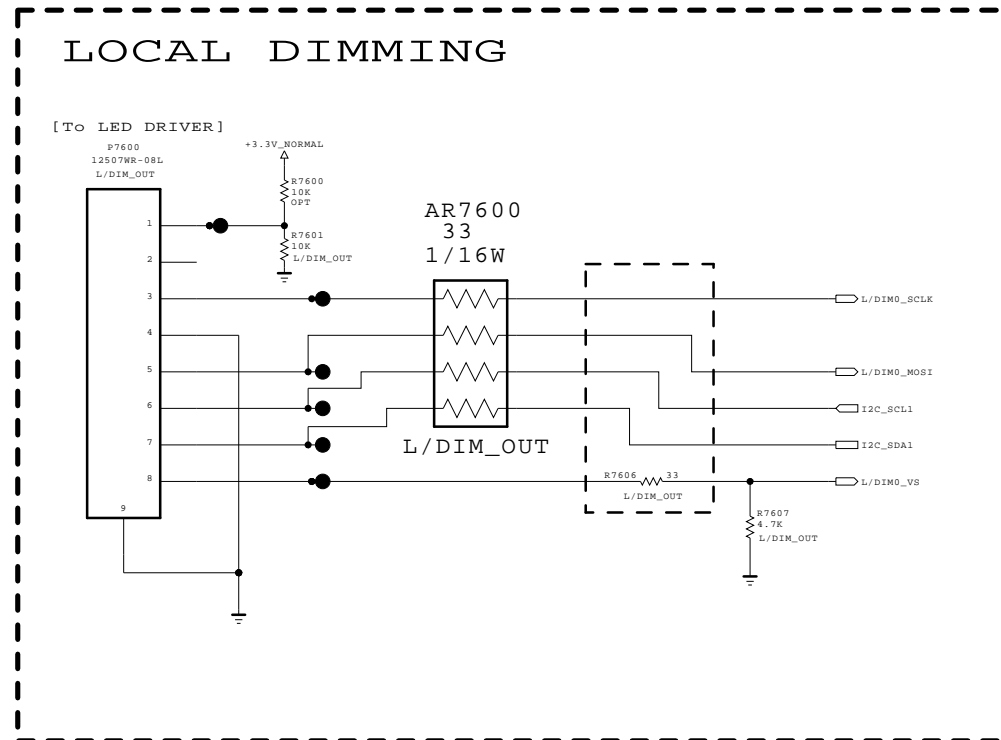

THE SYMBOL MARK OF THIS SCHEMATIC DIAGRAM INCORPORATES SPECIAL FEATURES IMPORTANT FOR PROTECTION FROM X-RADIATION. FILRE AND ELECTRICAL SHOCK HAZARDS, WHEN SERVICING IF IS ESSENTIAL THAT ONLY MANUFACTURES SPECIFIED PARTS BE USED FOR THE CRITICAL COMPONENTS IN THE SYMBOL MARK OF THE SCHEMATIC.

SECRET
LGElectronics



MODEL	LOCAL DIMMING	DATE	2011.12.13
BLOCK		SHEET	76 /

<POWER BLOCK>

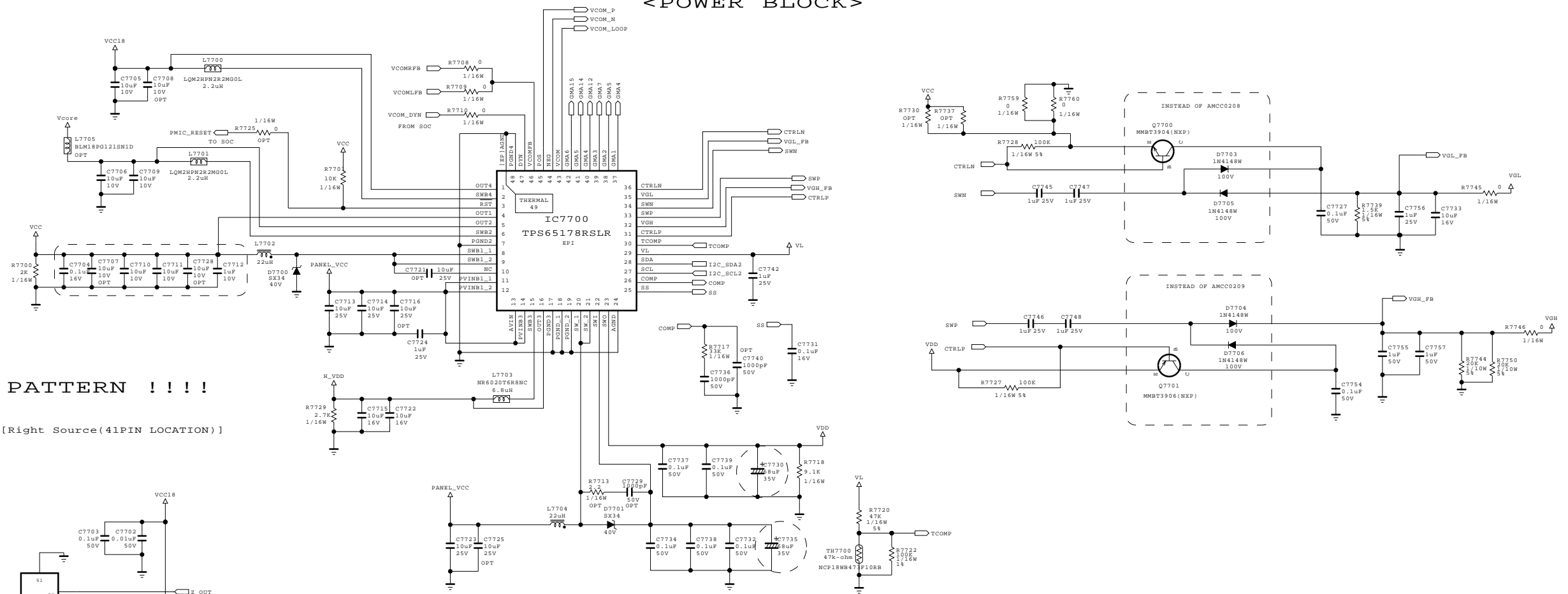

THIS IS REVERSE PATTERN !!!!

[Left Source(51PIN LOCATION)]

[Right Source(41PIN LOCATION)]

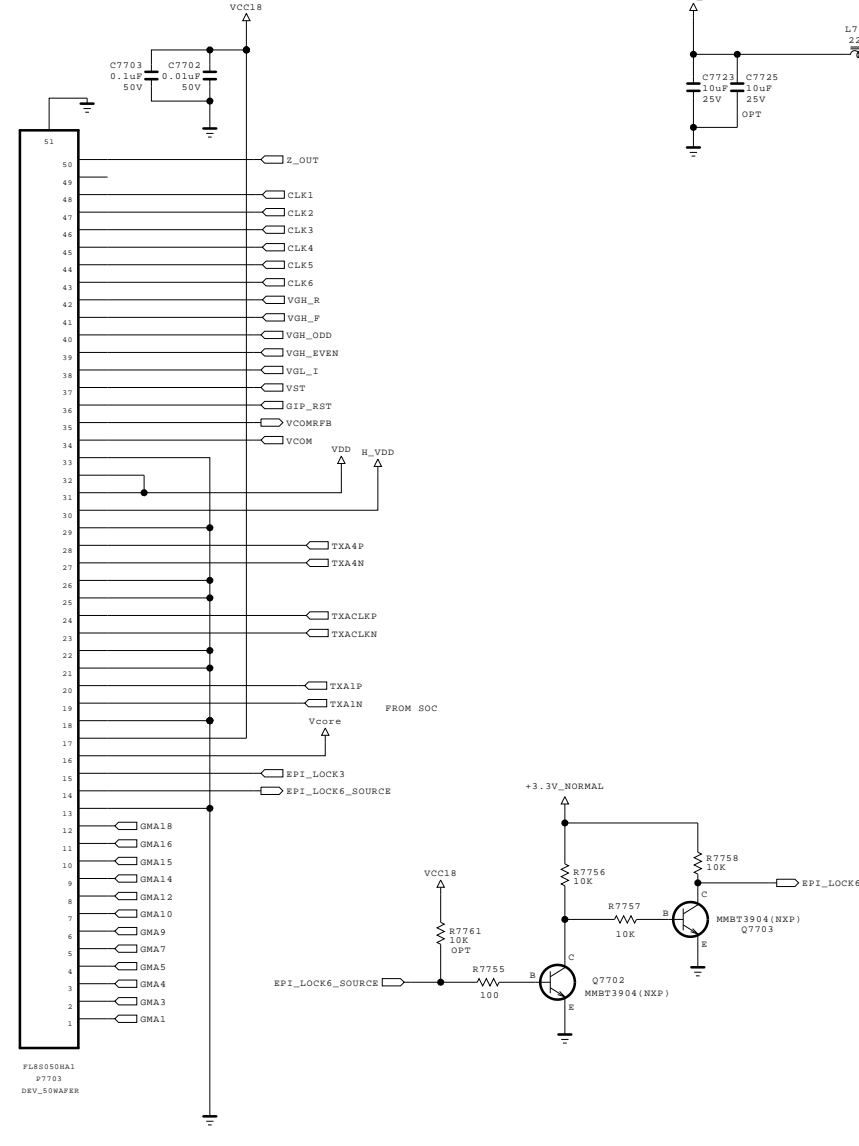
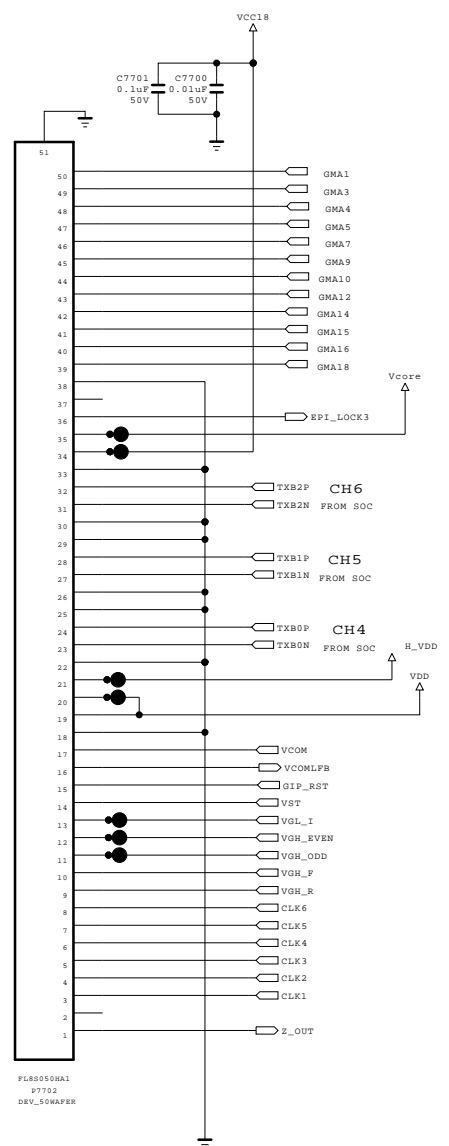

<LEVEL SHIFTER BLOCK>

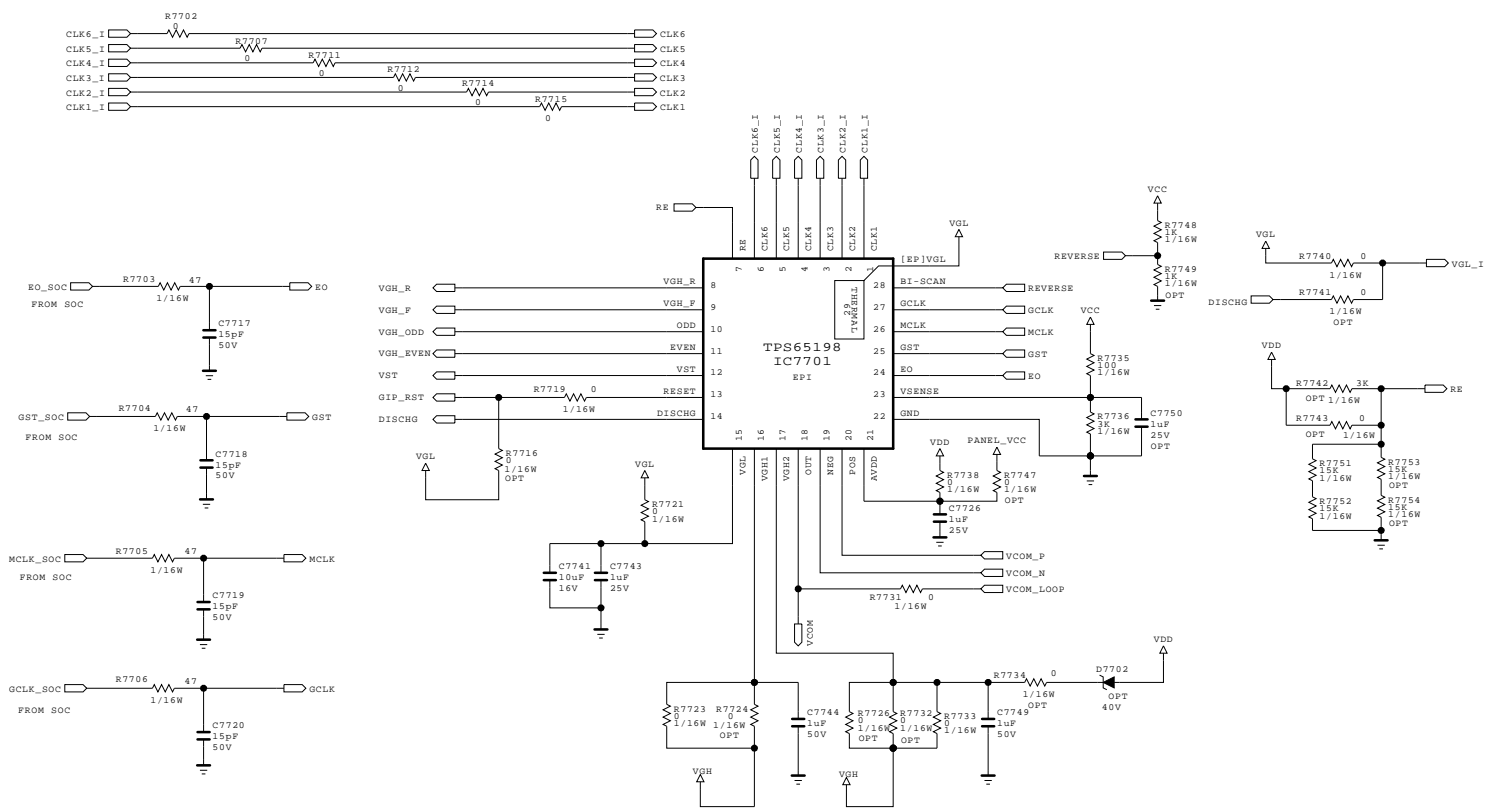

THE Δ SYMBOL MARK OF THIS SCHEMATIC DIAGRAM INCORPORATES SPECIAL FEATURES IMPORTANT FOR PROTECTION FROM X-RADIATION. FILRE AND ELECTRICAL SHOCK HAZARDS, WHEN SERVICING IF IS ESSENTIAL THAT ONLY MANUFACTURES SPECIFIED PARTS BE USED FOR THE CRITICAL COMPONENTS IN THE Δ SYMBOL MARK OF THE SCHEMATIC.

SECRET
LGElectronics



MODEL	DATE	2011.12.01
BLOCK	SHEET	77
T-Con		

eMMC I/F

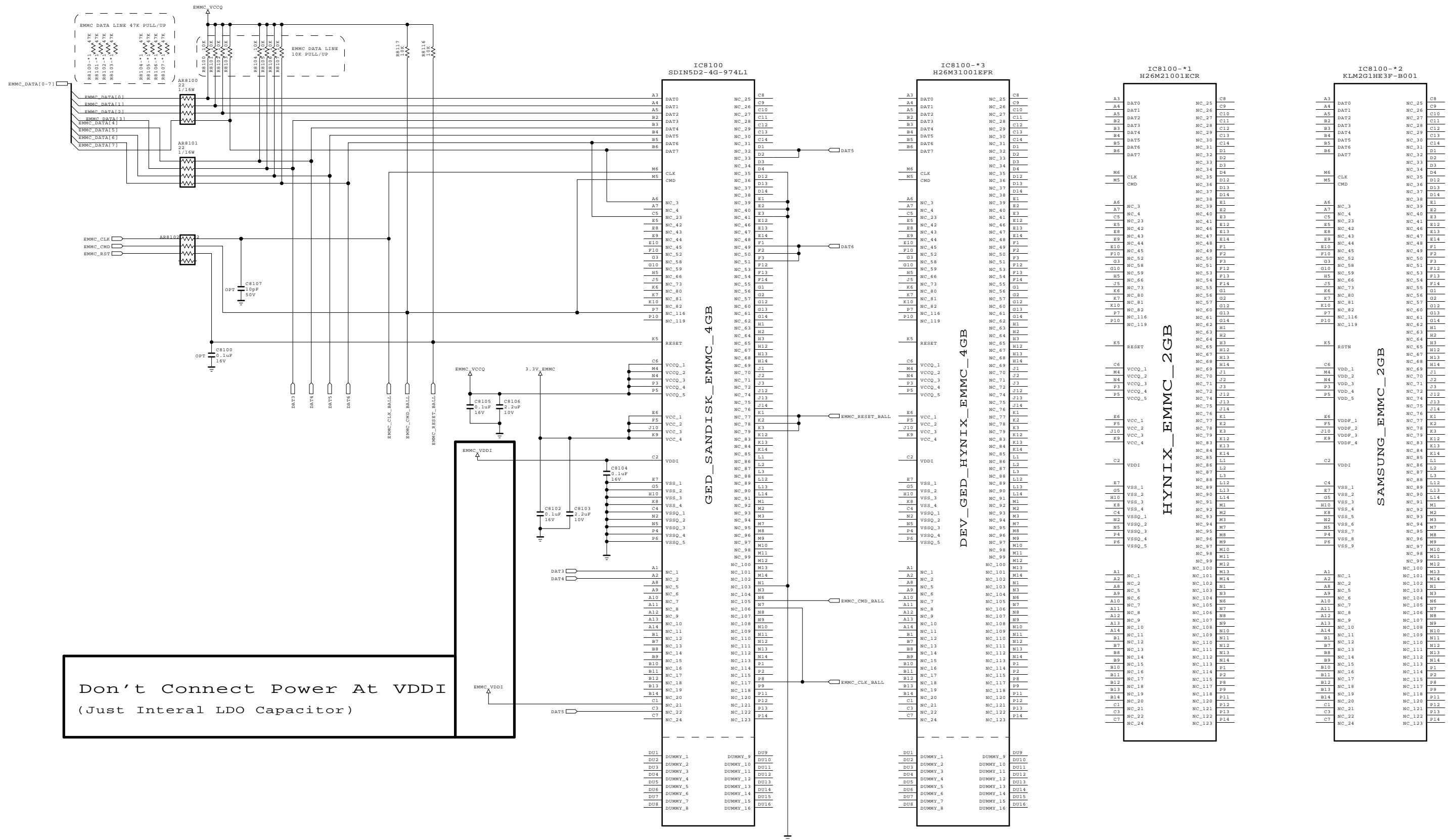

Don't Connect Power At VDDI
(Just Interual LDO Capacitor)

THE Δ SYMBOL MARK OF THIS SCHEMATIC DIAGRAM INCORPORATES SPECIAL FEATURES IMPORTANT FOR PROTECTION FROM X-RADIATION. FILRE AND ELECTRICAL SHOCK HAZARDS, WHEN SERVICING IF IS ESSENTIAL THAT ONLY MANUFACTURERS SPECIFIED PARTS BE USED FOR THE CRITICAL COMPONENTS IN THE Δ SYMBOL MARK OF THE SCHEMATIC.

SECRET
LGElectronics



MODEL BLOCK	eMMC	DATE SHEET	11.09.29
			81

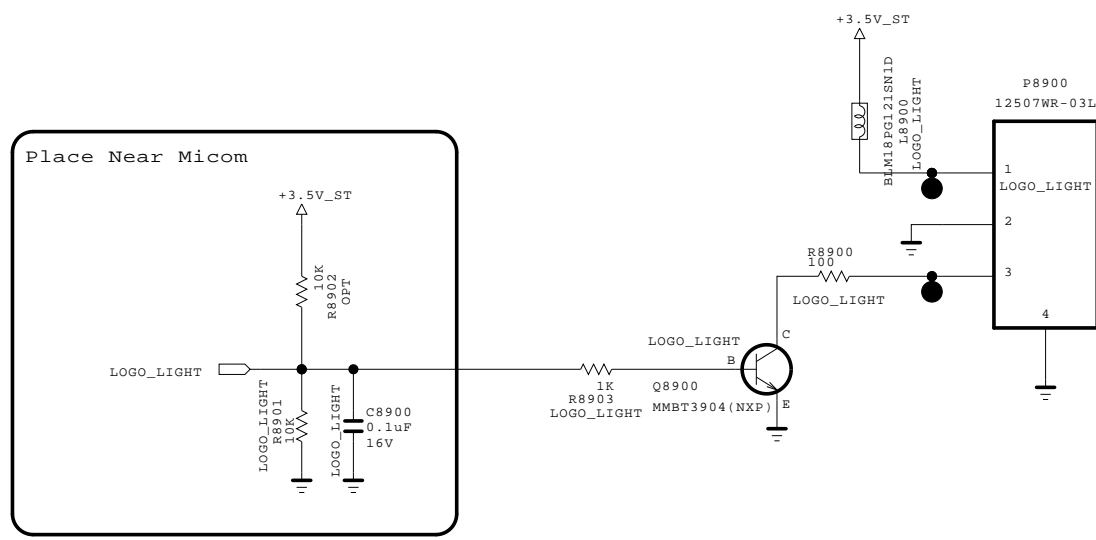

THE SYMBOL MARK OF THIS SCHEMATIC DIAGRAM INCORPORATES SPECIAL FEATURES IMPORTANT FOR PROTECTION FROM X-RADIATION. FILRE AND ELECTRICAL SHOCK HAZARDS, WHEN SERVICING IF IS ESSENTIAL THAT ONLY MANUFACTURES SPECIFIED PARTS BE USED FOR THE CRITICAL COMPONENTS IN THE SYMBOL MARK OF THE SCHEMATIC.

SECRET
LGElectronics



MODEL		DATE	
BLOCK		SHEET	/





**2012 LED/LCD TV
Engineering guide**



Contents of LCD TV Standard Repair Process

No.	Error symptom (High category)	Error symptom (Mid category)	Page	Remarks
1	A. Video error	No video/Normal audio	1	
2		No video/No audio	2	
3		Video error, video lag/stop, fail tuning	3, 4	
4		Color error	5	
5		Vertical/Horizontal bar, residual image, light spot, external device color error	6	
6	B. Power error	No power	7	
7		Off when on, off while viewing, power auto on/off	8	
8	C. Audio error	No audio/Normal video	9	
9		Wrecked audio/discontinuation/noise	10	
10	D. Function error	No response in remote controller, key error, recording error, memory error	11	
11		External device recognition error	12	
12	E. Noise	Circuit noise, mechanical noise	13	
13	F. Exterior error	Exterior defect	14	

First of all, Check whether there is SVC Bulletin in GCSC System for these model.

Contents of LCD TV Standard Repair Process Detail Technical Manual

No.	Error symptom	Content	Page	Remarks
1	A. Video error_ No video/Normal audio	Check LCD back light with naked eye	A1	
2		LED driver B+ 24V measuring method	A2	
3		Check White Balance value	A3	
4		Power Board voltage measuring method	A4	
6	A. Video error_ No video/Video lag/stop	TUNER input signal strength checking method	A6	
7		LCD-TV Version checking method	A7	
9	A. Video error_Color error	LCD TV connection diagram	A8	
10		Tuner Checking Part	A9	
11		Check Link Cable (LVDS) reconnection condition	A10 A11	A10 : 32/37/42/47/55 A11 : 32 AUO
12		Adjustment Test pattern – ADJ Key	A12	
13	A. Video error_Vertical/Horizontal bar, residual image, light spot	LCD TV connection diagram	A8	
14		Check Link Cable (LVDS) reconnection condition	A10 A11	A10 : 32/37/42/47/55 A11 : 32 AUO
15		Adjustment Test pattern – ADJ Key	A12	
16	<Appendix> Defected Type caused by T-Con/ Inverter/ Module	Exchange T-Con Board (1)	A-1/5	
17		Exchange T-Con Board (2)	A-2/5	
18		Exchange LED driver Board (PSU)	A-3/5	55" : driver board Other : PSU
19		Exchange Module itself (1)	A-4/5	
20		Exchange Module itself (2)	A-5/5	

Continue to the next page

LCD TV	Error symptom	A. Video error	Established date	2010. 12 .14	
		No video/ Normal audio	Revised date		1/13

**First of all, Check whether all of cables between board is inserted properly or not.
(Main B/D↔ Power B/D, LVDS Cable,Speaker Cable,IR B/D Cable,,,)**

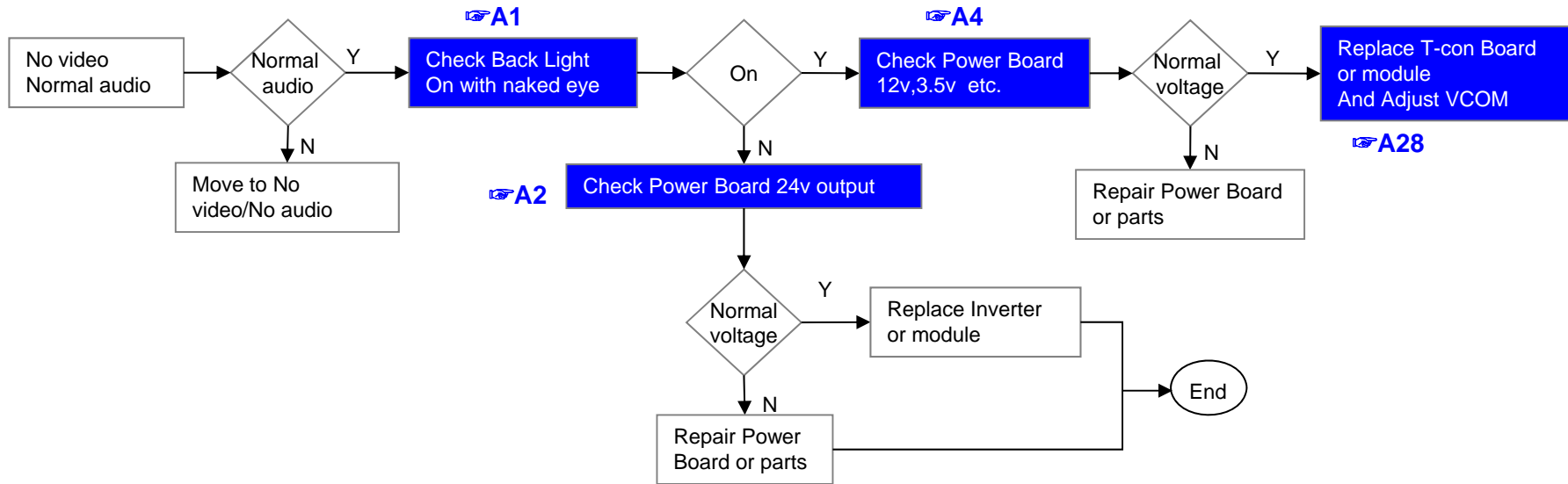

※Precaution A7 & A3



LCD TV	Error symptom	A. Video error	Established date	2010. 12 .14	
		No video/ No audio	Revised date		2/13

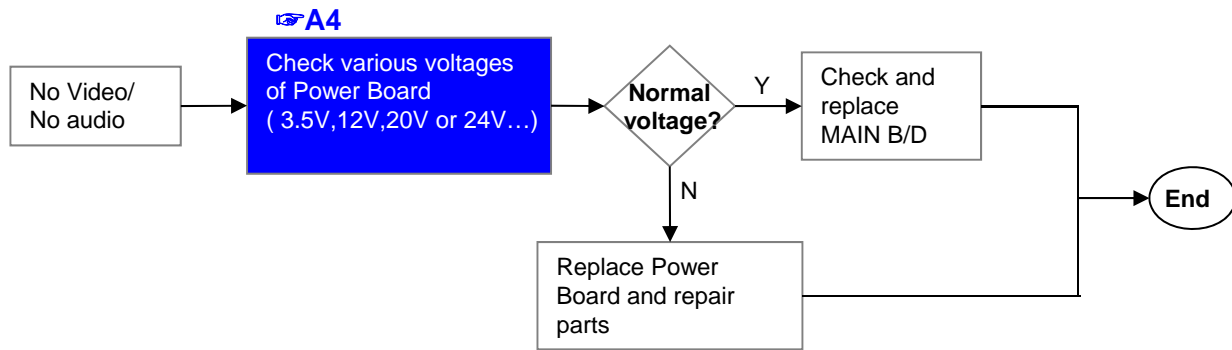

LCD TV	Error symptom	A. Picture Problem	Established date	2010. 12 .14	
		Picture broken/ Freezing	Revised date		3/13

A6

Check RF Signal level

- . By using Digital signal level meter
- . By using Diagnostics menu on OSD
(Menu → Set up → Support → Signal Test)
- Signal strength (Normal : over 50%)
- Signal Quality (Normal: over 50%)

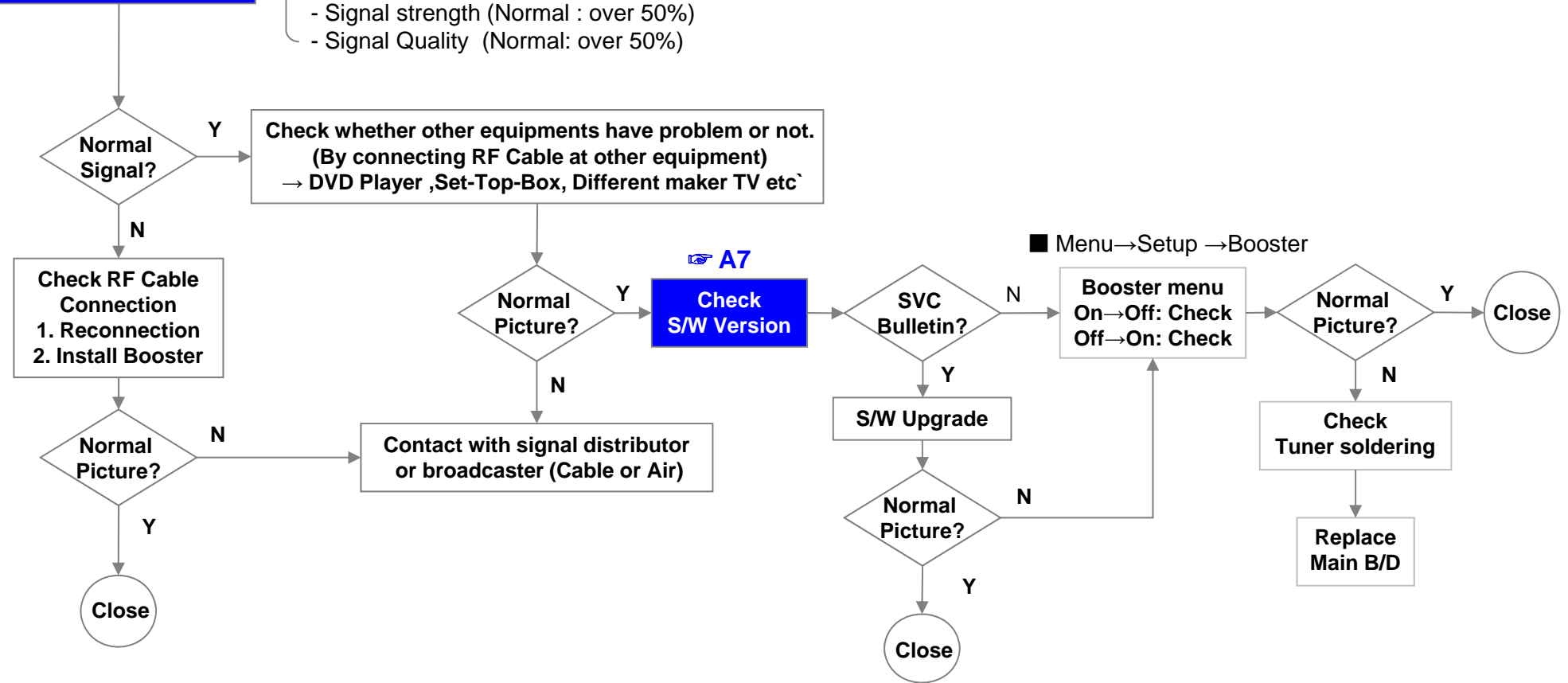

A7

Check S/W Version

■ Menu → Setup → Booster

Booster menu
On → Off: Check
Off → On: Check

Check Tuner soldering

Replace Main B/D

LCD TV	Error symptom	A. Picture Problem (DVB-S/S2)	Established date	2011. 01 .24	
		Tuning fail, Picture broken/ Freezing	Revised date		3/13

A6

Check RF Signal level

Check RF signal cable (DVB satellite signal or not)
 Check whether other equipments have problem or not.
 (By connecting RF Cable at other equipment)
 → Set-Top-Box, Different maker TV etc

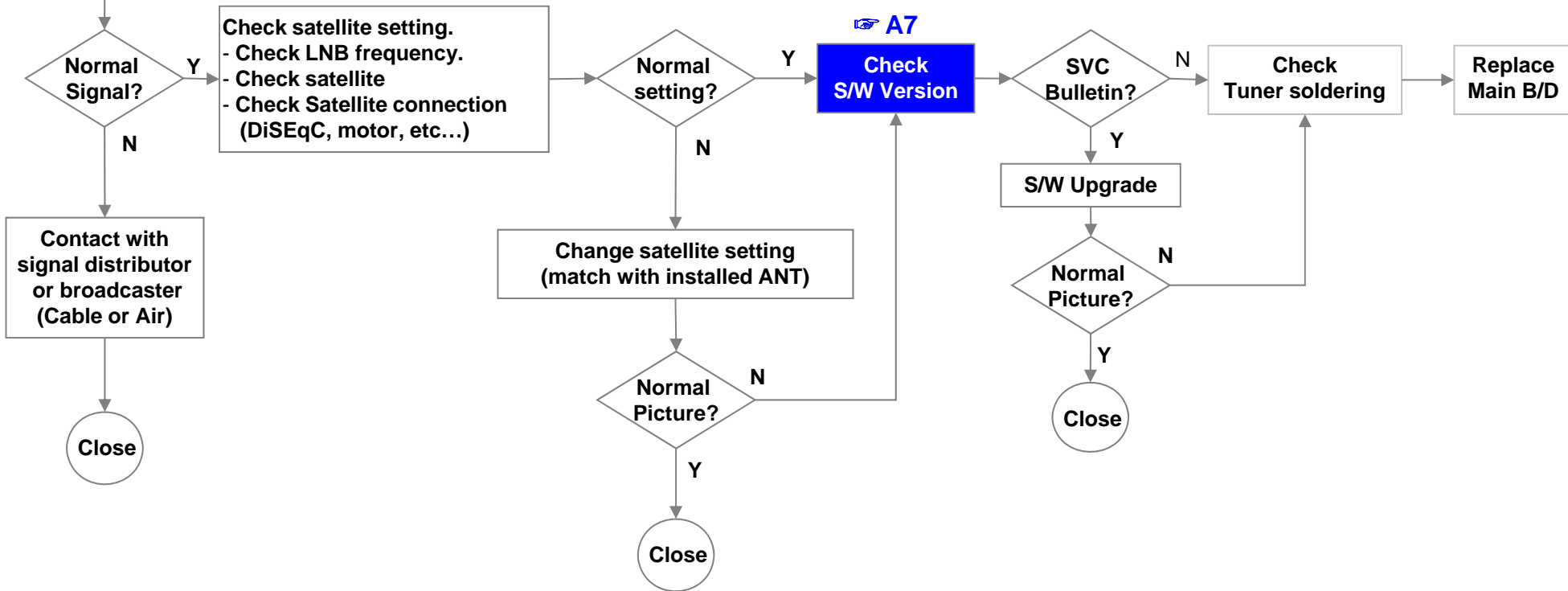

A7

Check S/W Version

SVC Bulletin?

Check Tuner soldering

Replace Main B/D

S/W Upgrade

Normal Picture?

Close

Close

Close

LCD TV	Error symptom	A. Video error	Established date	2010. 12 .14	
		Color error	Revised date		4/13

A8

Check color by input
 -External Input
 -COMPONENT
 -RGB
 -HDMI/DVI

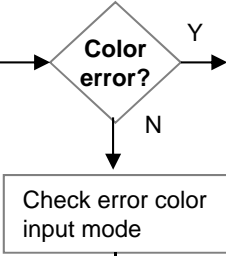

A10/ A11

※ Check and replace Link Cable (LVDS) and contact condition

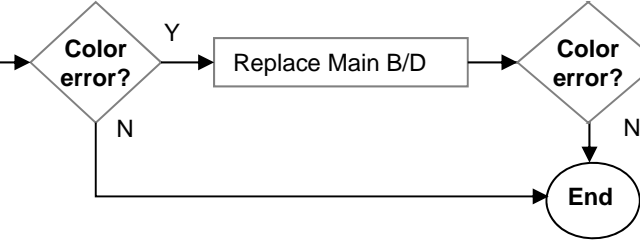

A12

Check Test pattern

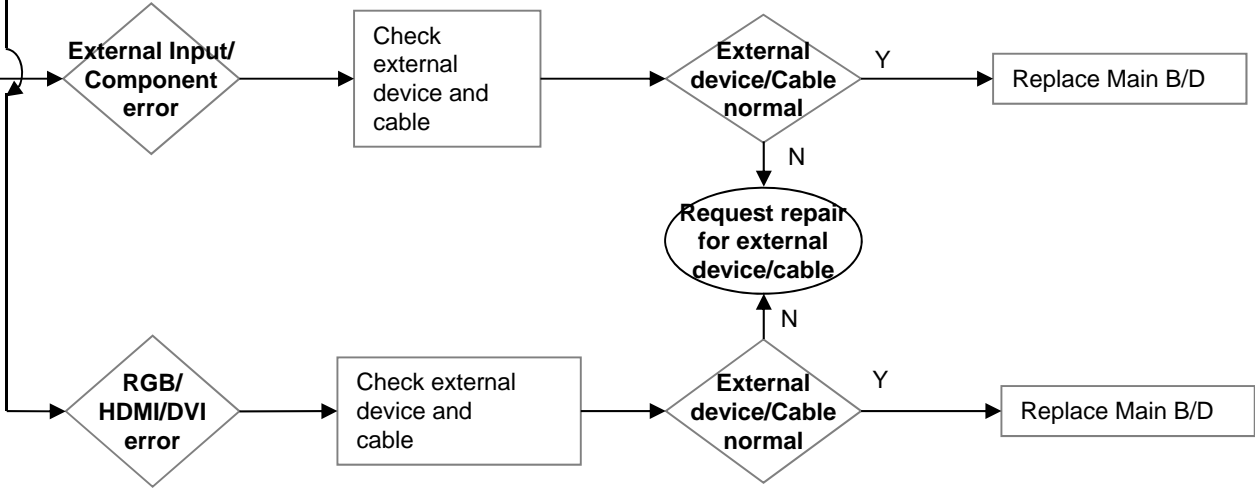

LCD TV	Error symptom	A. Video error	Established date	2010. 12 .14	
		Vertical / Horizontal bar, residual image, light spot, external device color error	Revised date		5/13

Vertical/Horizontal bar, residual image, light spot

A8

Check color condition by input
 -External Input
 -Component
 -RGB
 -HDMI/DVI

A12

Check Test pattern

A10/ A11

Check and replace Link Cable

A28

Replace Main B/D (adjust VCOM)

For LGD panel

For other panel

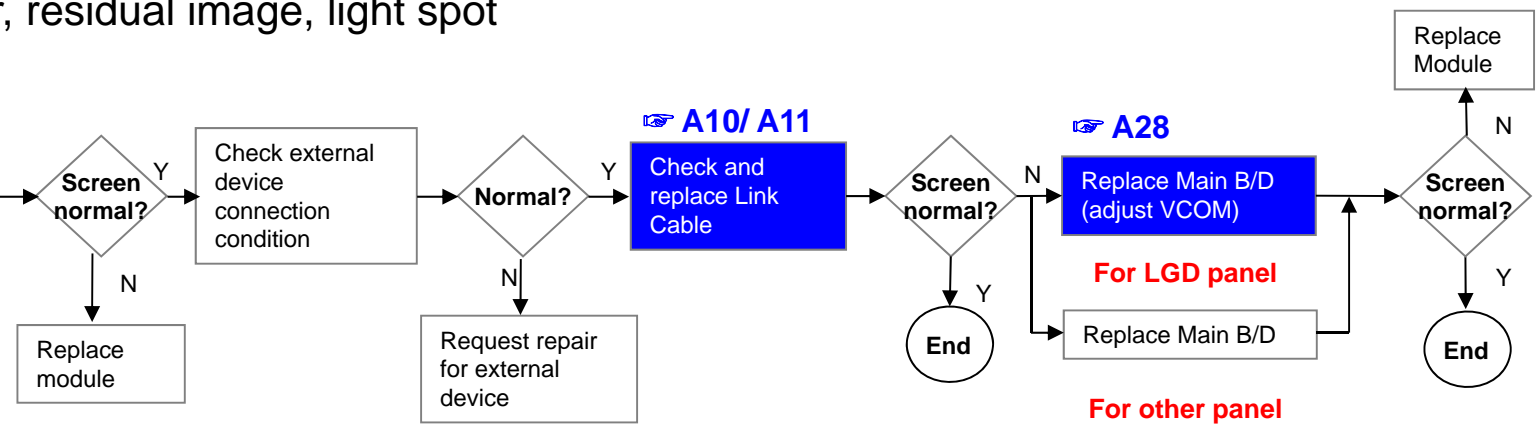

External device screen error-Color error

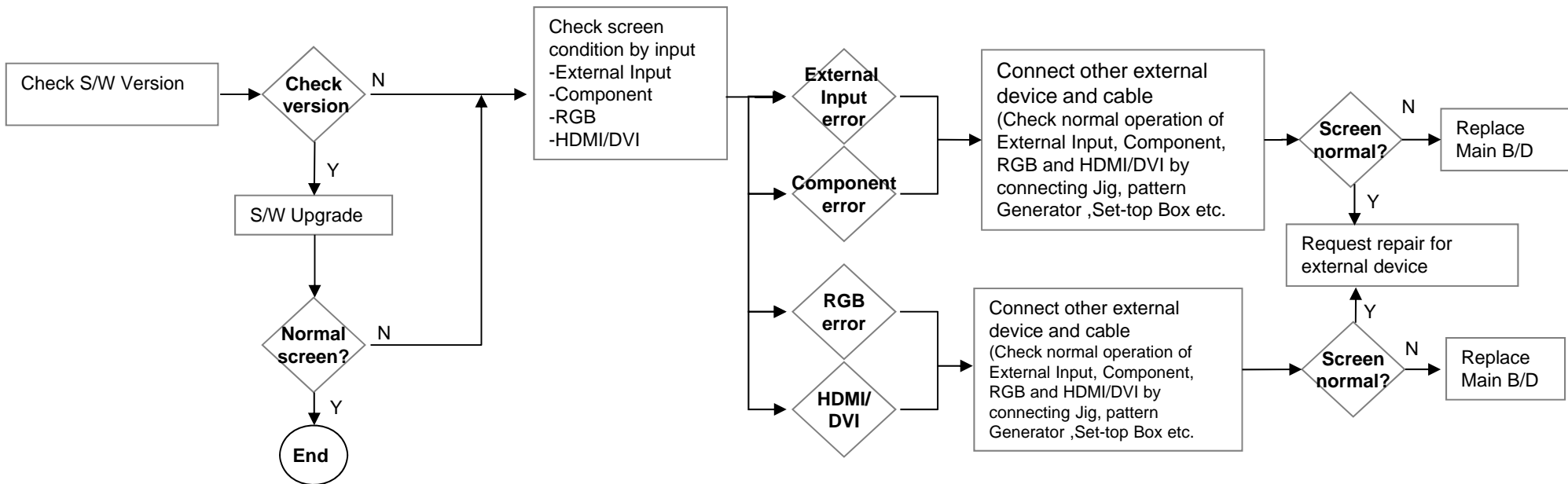

LCD TV	Error symptom	B. Power error	Established date	2010. 12 .14	
		No power	Revised date		6/13

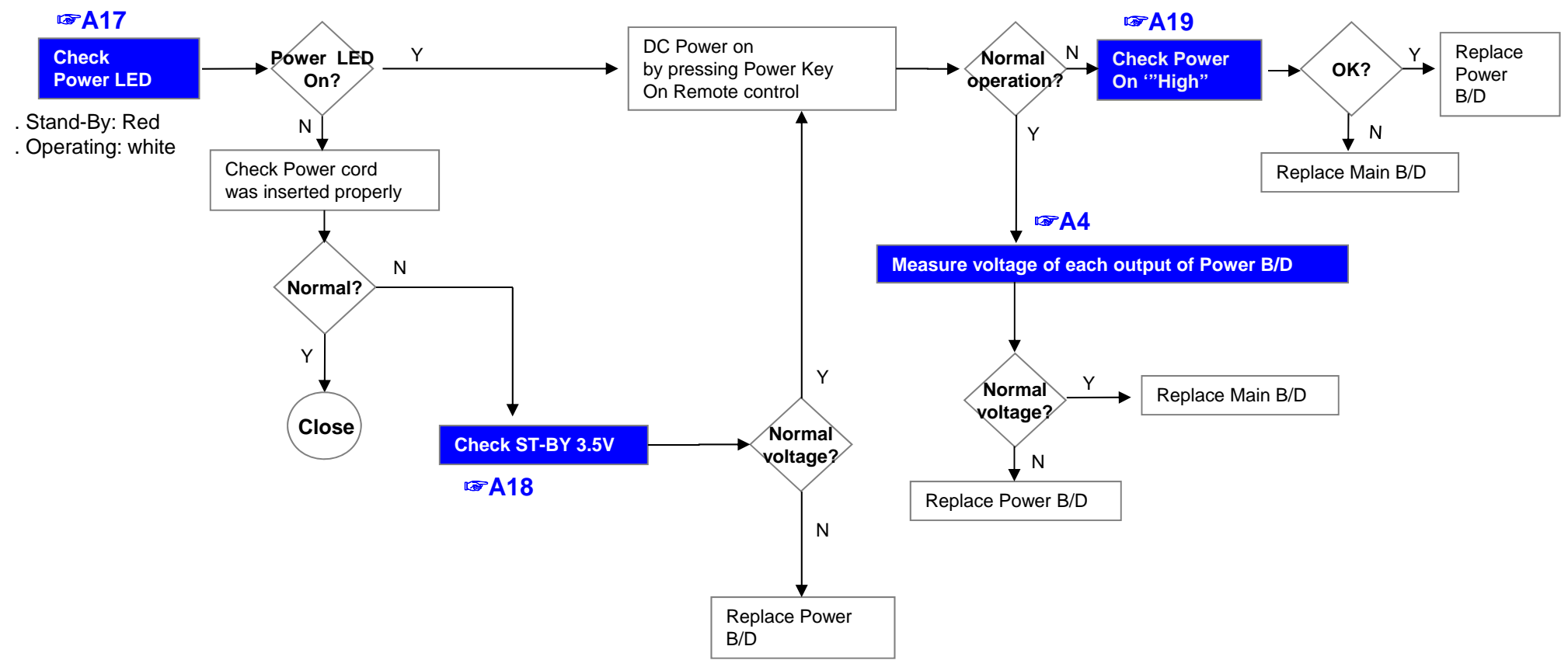

LCD TV	Error symptom	B. Power error	Established date	2010. 12 .14	
		Off when on, off while viewing, power auto on/off	Revised date		7/13

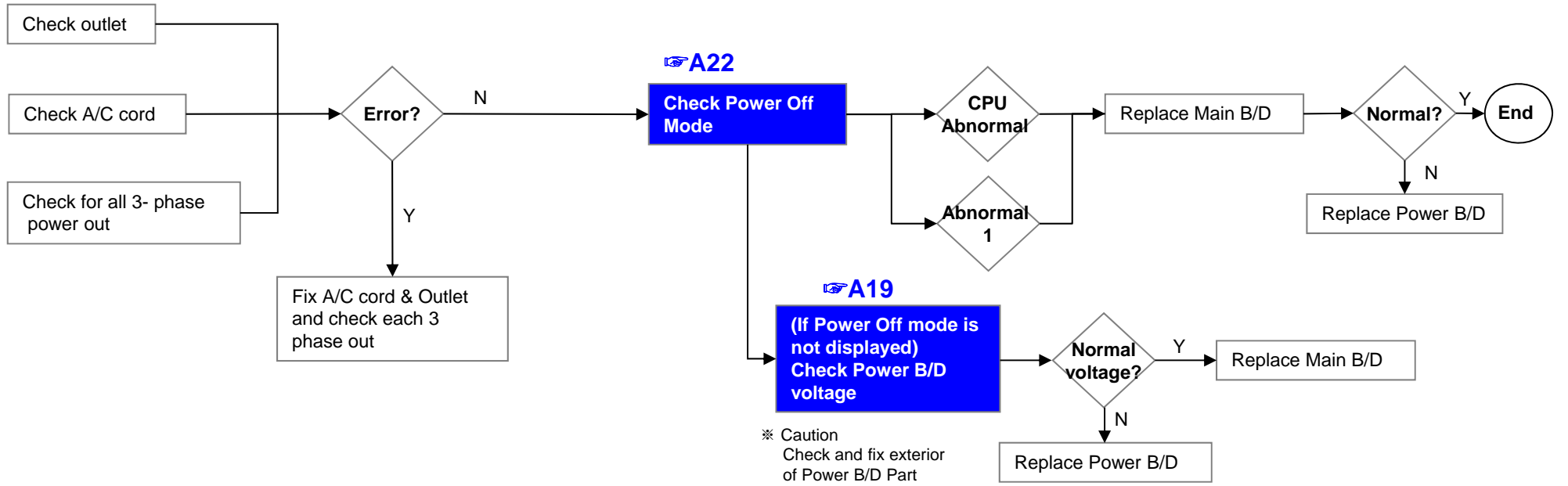

* Please refer to the all cases which can be displayed on power off mode.

Status	Power off List	Explanation
Normal	"POWEROFF_REMOTEKEY"	Power off by REMOTE CONTROL
	"POWEROFF_OFFTIMER"	Power off by OFF TIMER
	"POWEROFF_SLEEPTIMER"	Power off by SLEEP TIMER
	"POWEROFF_INSTOP"	Power off by INSTOP KEY
	"POWEROFF_AUTOOFF"	Power off by AUTO OFF
	"POWEROFF_ONTIMER"	Power off by ON TIMER
	"POWEROFF_RS232C"	Power off by RS232C
	"POWEROFF_RESREC"	Power off by Reserved Record
	"POWEROFF_RECEND"	Power off by End of Recording
	"POWEROFF_SWDOWN"	Power off by S/W Download
Abnormal	"POWEROFF_UNKNOWN"	Power off by unknown status except listed case
	"POWEROFF_ABNORMAL1"	Power off by abnormal status except CPU trouble
	"POWEROFF_CPUABNORMAL"	Power off by CPU Abnormal

LCD TV	Error symptom	C. Audio error	Established date	2010. 12 .14	
		No audio/ Normal video	Revised date		8/13

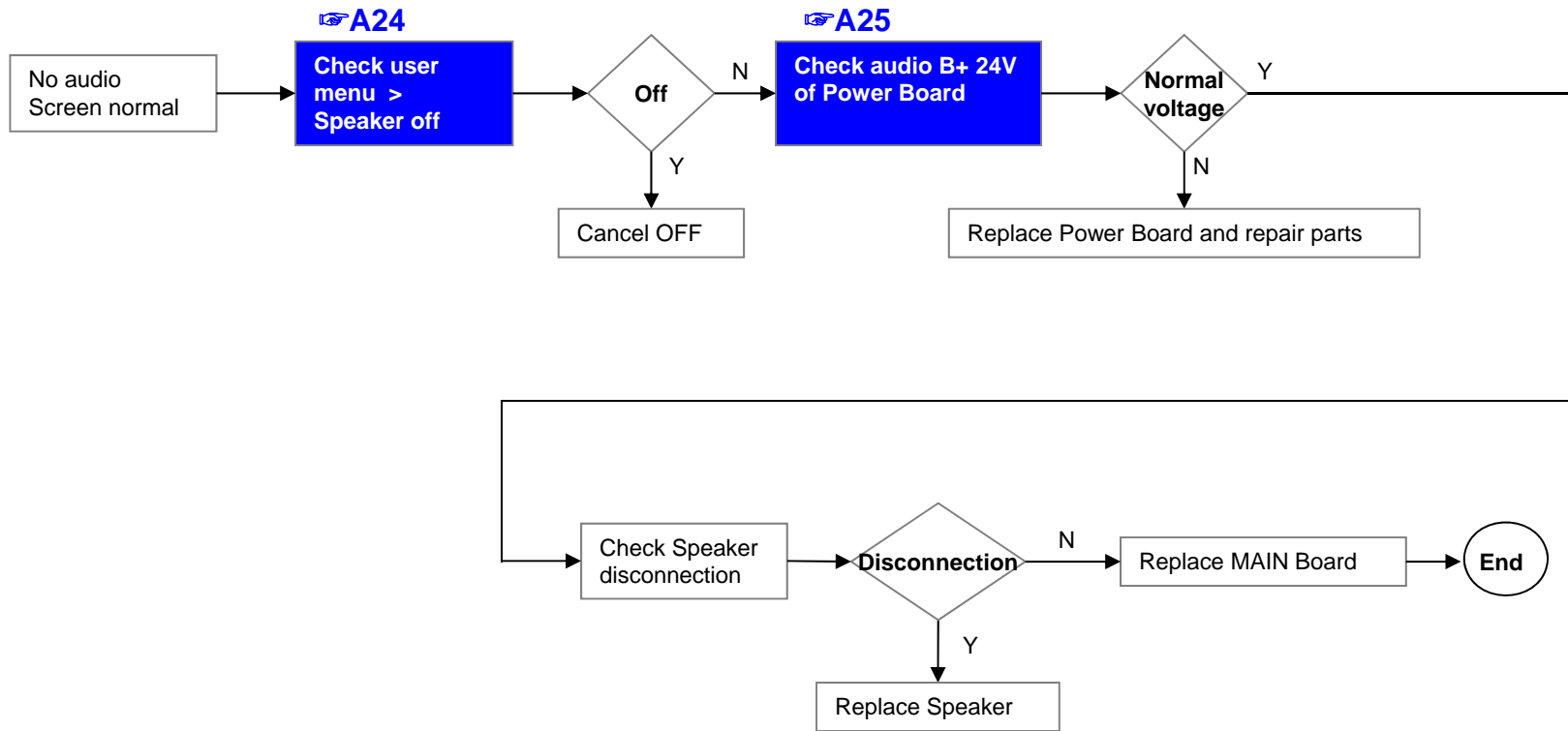

LCD TV	Error symptom	C. Audio error	Established date	2010. 12 .14	
		Wrecked audio/ discontinuation/noise	Revised date		9/13

→ abnormal audio/discontinuation/noise is same after “Check input signal” compared to No audio

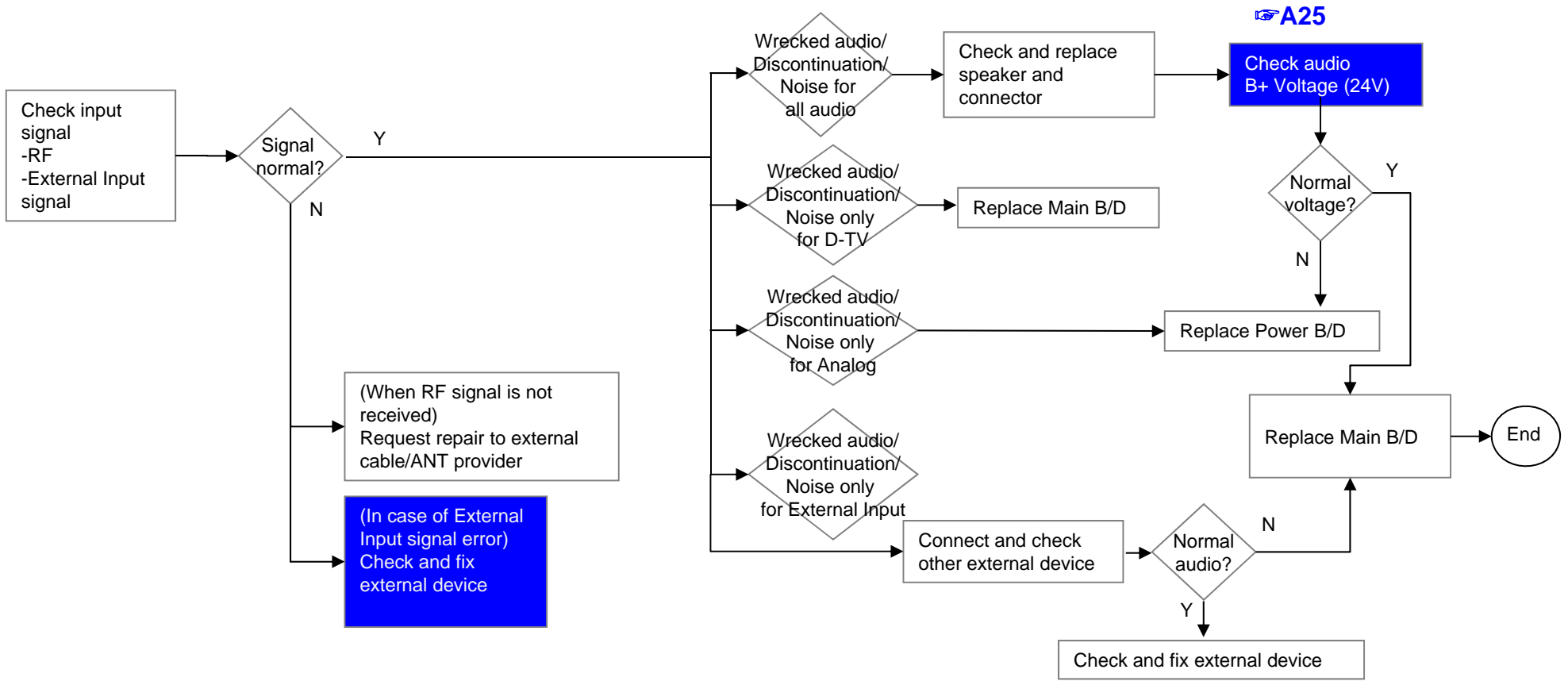

LCD TV	Error symptom	D. General Function Problem	Established date	2010. 12 .14	
		Remote control & Local switch checking	Revised date		10/13

1. Remote control(R/C) operating error

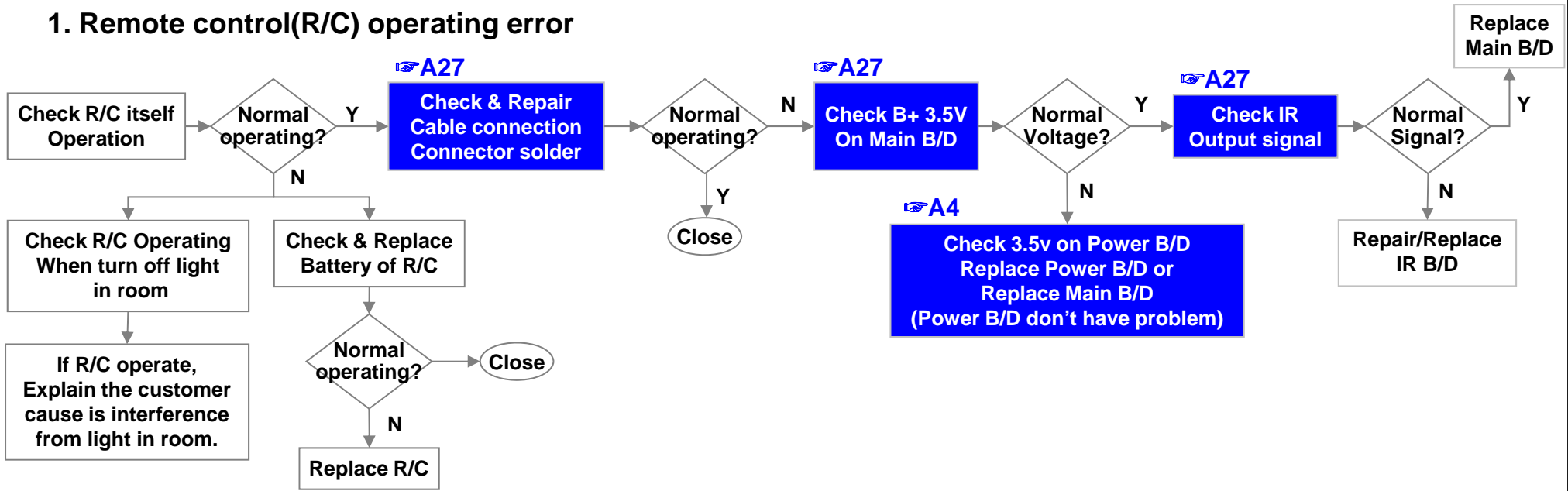

LCD TV	Error symptom	D. Function error	Established date	2010. 12 .14	
		External device recognition error	Revised date		11/13

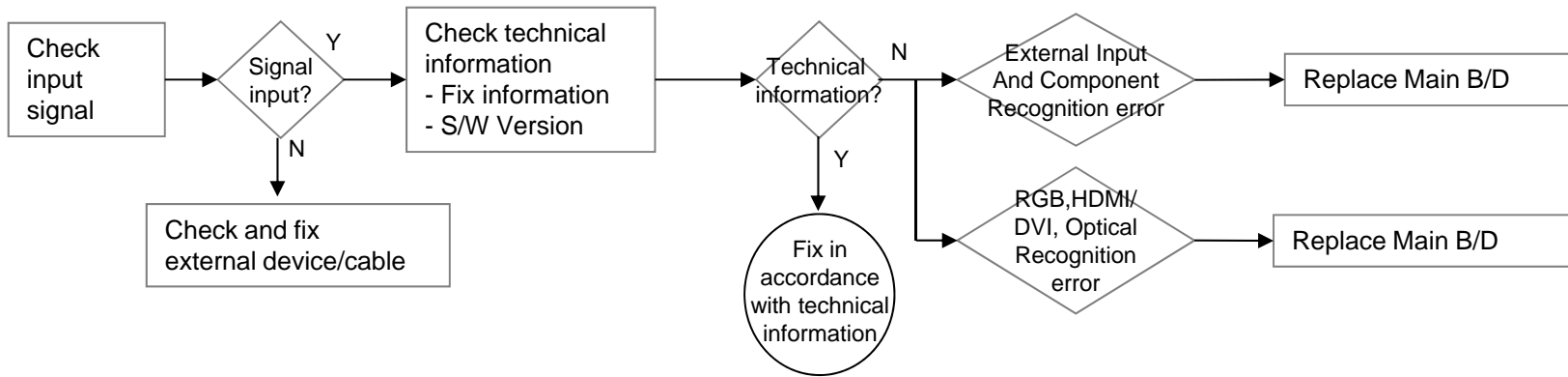

LCD TV	Error symptom	E. Noise	Established date	2010. 12 .14	
		Circuit noise, mechanical noise	Revised date		12/13

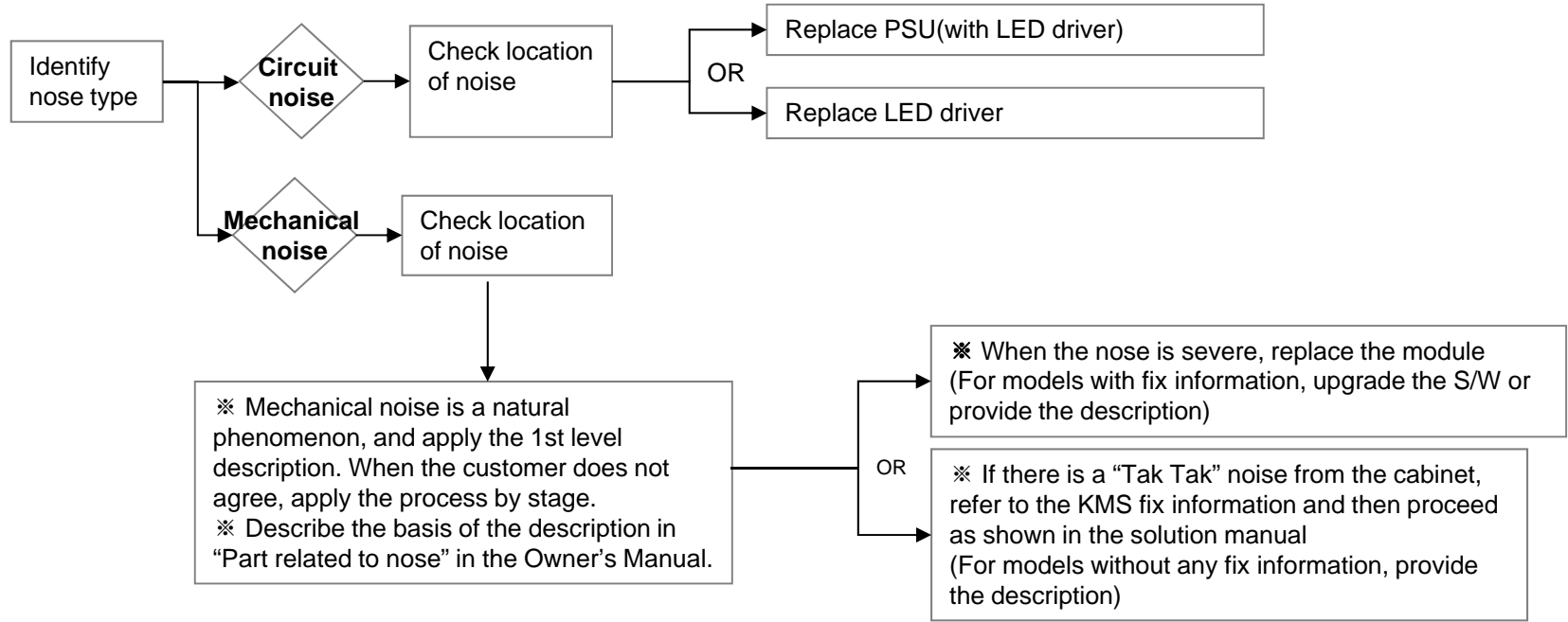

LCD TV	Error symptom	F. Exterior defect	Established date	2010. 12 .14	
		Exterior defect	Revised date		13/13

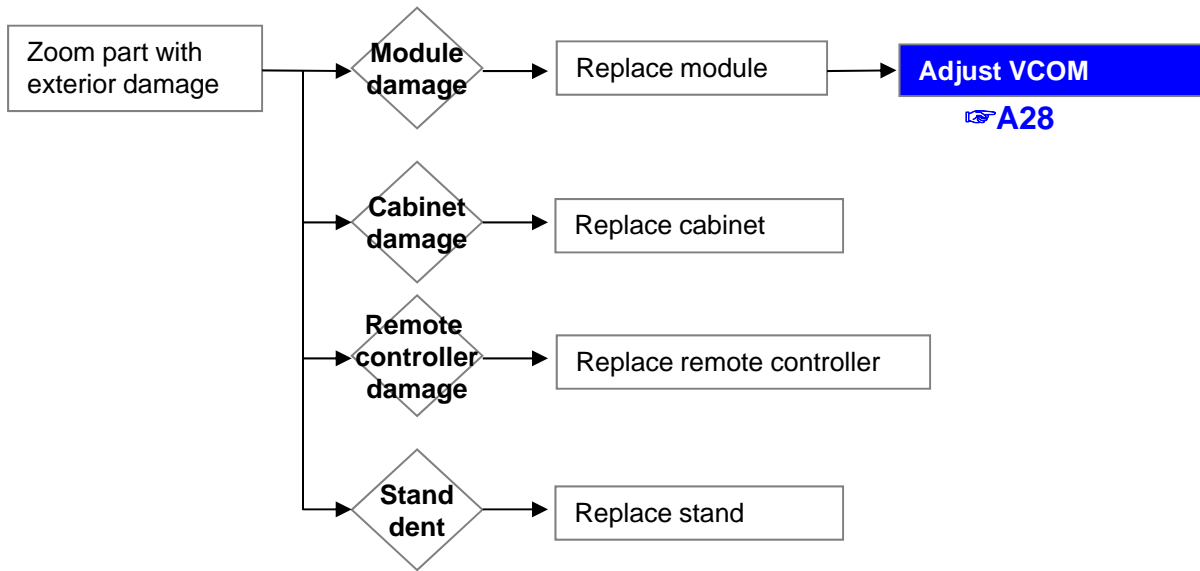

Contents of LCD TV Standard Repair Process Detail Technical Manual

Continued from previous page

No.	Error symptom	Content	Page	Remarks
21	B. Power error_No power	Check front display LED	A17	
22		Check power input Voltage & ST-BY 5V	A18	
23		Checking method when power is ON	A19	
24		POWER BOARD voltage measuring method	A4	
25				
26	B. Power error_Off when on, off while viewing	POWER OFF MODE checking method	A22	
27	B. Power error_Off when on, off while viewing	POWER BOARD PIN voltage checking method	A19	
28	C. Audio error_No audio/Normal video	Checking method in menu when there is no audio	A24	
29		Voltage and speaker checking method when there is no audio	A25	
30	C. Audio error_Wrecked audio/discontinuation	Voltage and speaker checking method in case of audio error	A25	
31	D. Function error_ No response in remote controller, key error	Remote controller operation checking method	A27	
32	D. VCOM Adjustment	Sequence of the Vcom adjustment	A28	

Standard Repair Process Detail Technical Manual

LCD TV	Error symptom	A. Video error_No video/Normal audio	Established date	2010. 12 .14	
	Content	Check White Balance value	Revised date		A4

<ALL MODELS>

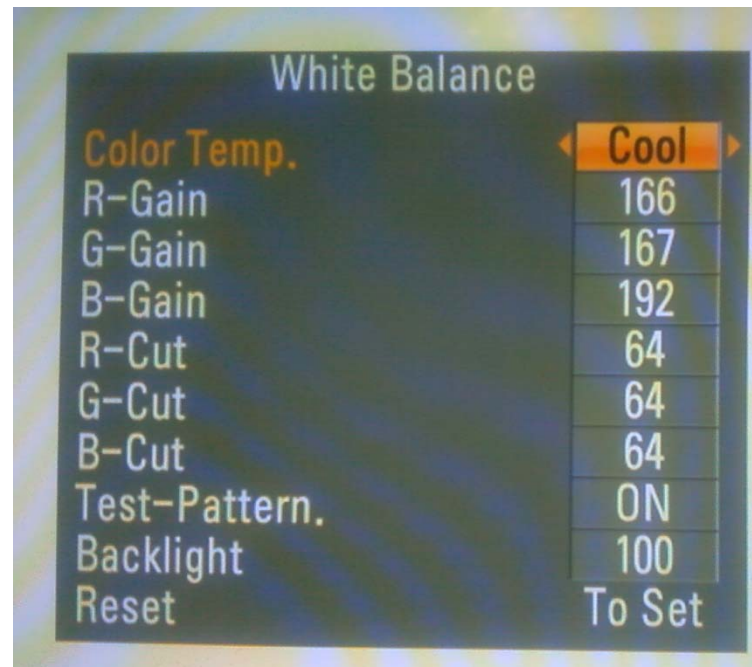
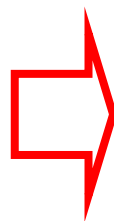
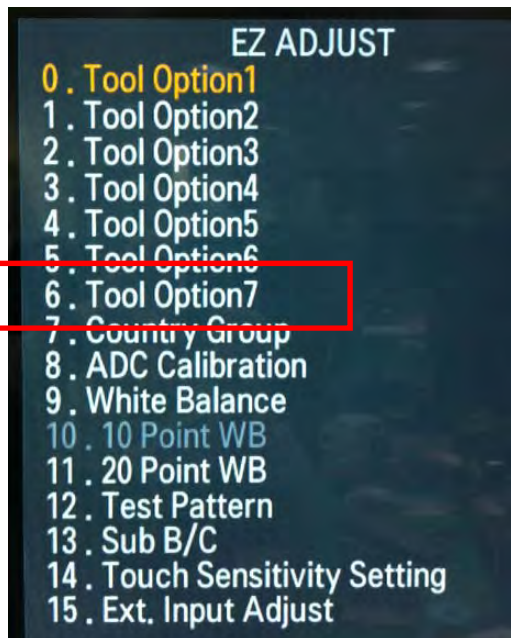

Entry method

1. Press the ADJ button on the remote controller for adjustment.
2. Enter into White Balance of item 7.
3. After recording the R, G, B (GAIN, Cut) value of Color Temp (Cool/Medium/Warm), re-enter the value after replacing the MAIN BOARD.

Standard Repair Process Detail Technical Manual

LCD TV	Error symptom	A. Video error_No video/ Audio	Established date	2010. 12 .14	
	Content	Power Board voltage measuring method	Revised date		A5

Check the DC 24V, 12V, 3.5V.

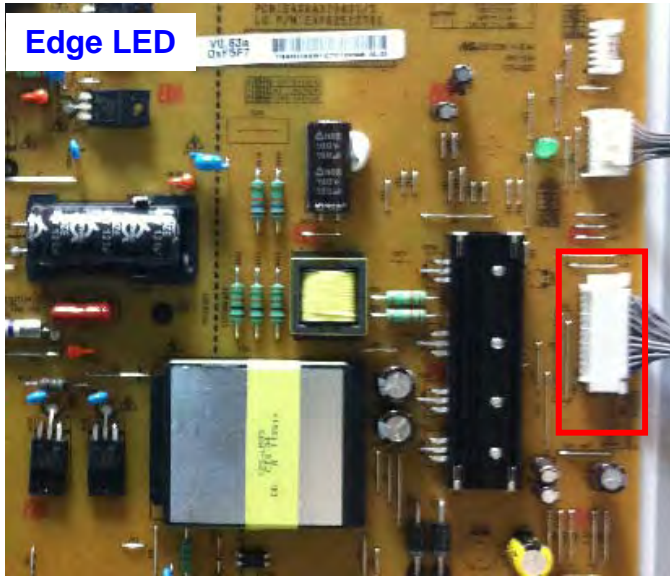

24 Pin (Power Board ↔ Main Board) – Common			
SMAW200-H24S (YEONHO)			
1	Power on	2	24V
3	24V	4	24V
5	GND	6	GND
7	GND	8	GND
9	3.5V	10	3.5V
11	3.5V	12	3.5V
13	GND	14	GND
15	GND	16	GND
17	12V	18	Inverter On/off
19	12V	20	Lamp : A-Dim LED : N.C
21	12V	22	PWM Dim #1
23	GND/P_DIM2 • Lamp SCANNING Model : PWM Dim #2	24	Error-out

Standard Repair Process Detail Technical Manual

LCD TV	Error symptom	A. Video error_Video error, video lag/stop	Established date	2010. 12 .14	
	Content	TUNER input signal strength checking method	Revised date		A6

<ALL MODELS>

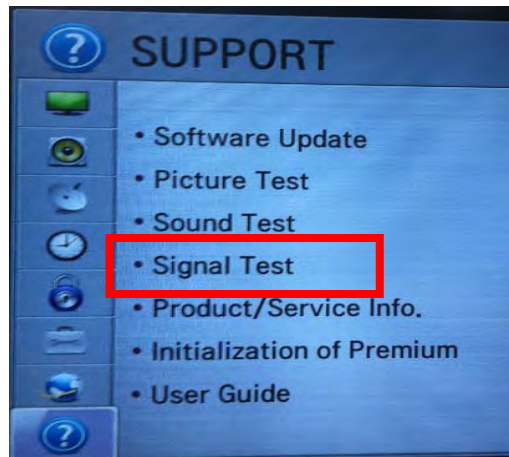

MENU -> Set up -> support -> signal test
-> select channel

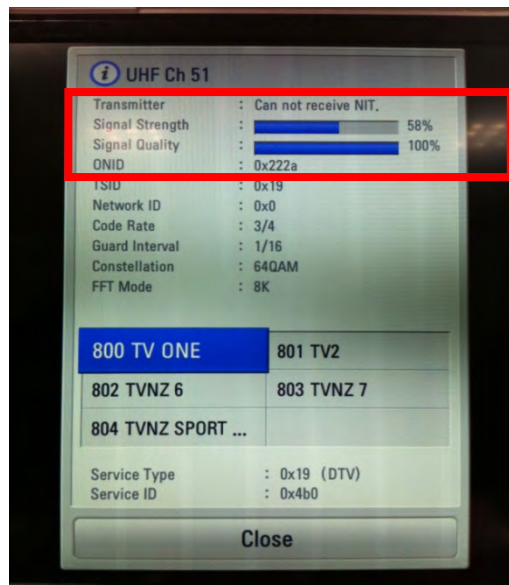

When the signal is strong, use the attenuator (-10dB, -15dB, -20dB etc.)



Standard Repair Process Detail Technical Manual

LCD TV	Error symptom	A. Video error_Video error, video lag/stop	Established date	2010. 12 .14	
	Content	LCD-TV Version checking method	Revised date		A7

<ALL MODELS>

1. Checking method for remote controller for adjustment

Version

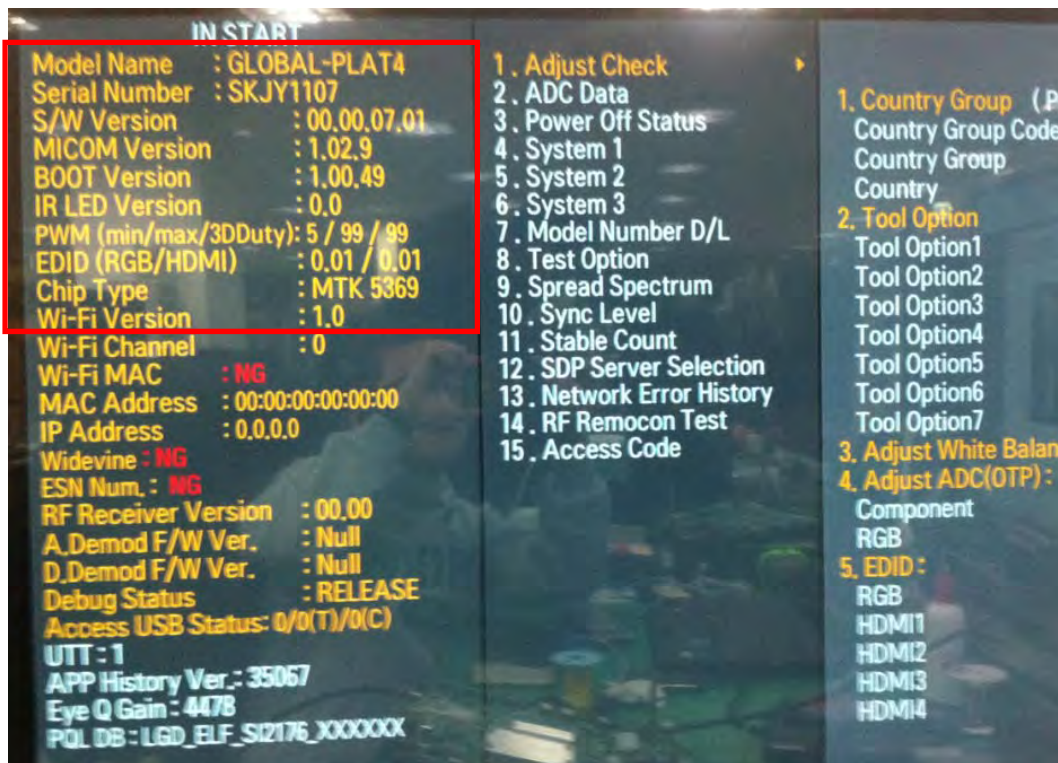

Press the IN-START with the remote controller for adjustment

Standard Repair Process Detail Technical Manual

LCD TV	Error symptom	A. Video error _Vertical/Horizontal bar, residual image, light spot	Established date	2010. 12 .14	
	Content	LCD TV connection diagram (1)	Revised date		A8

<ALL MODELS>



As the part connecting to the external input, check the screen condition by signal

Standard Repair Process Detail Technical Manual

LCD TV	Error symptom	A. Video error_Video error, video lag/stop	Established date	2010. 12 .14	
	Content	TUNER checking part	Revised date		A9

<ALL MODELS>

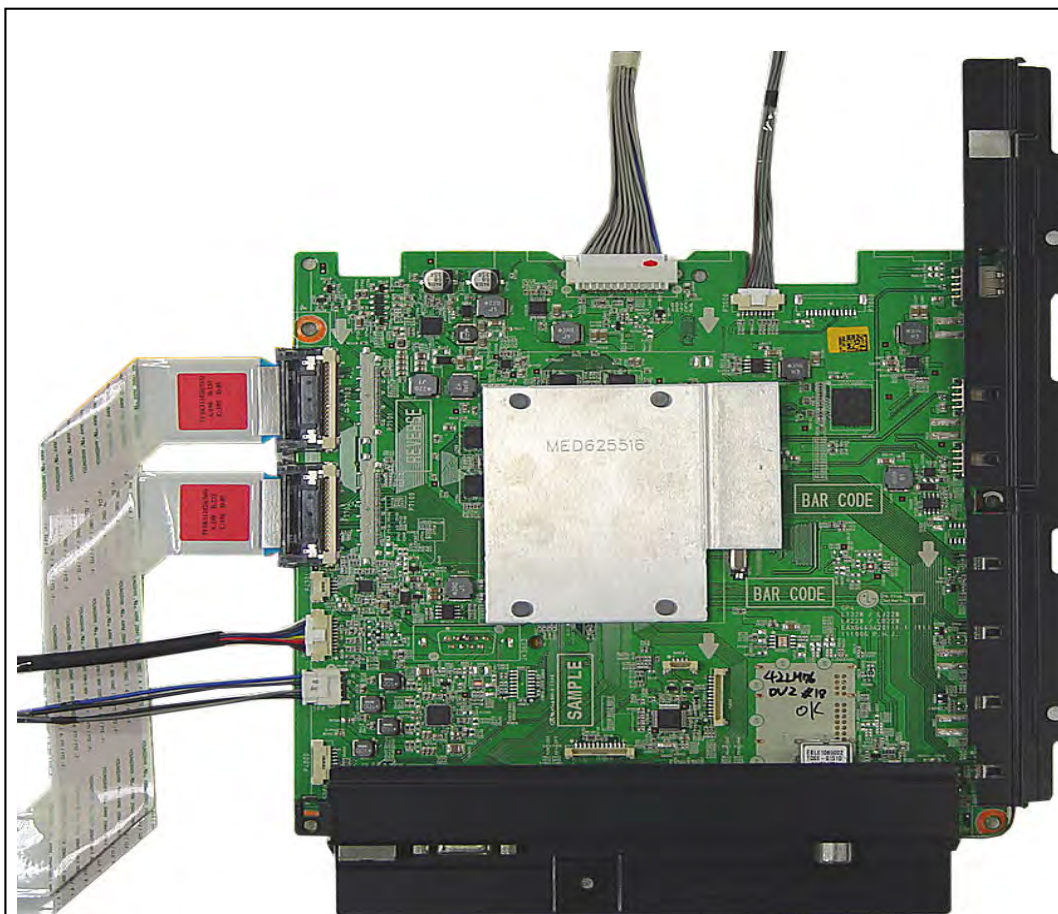

Checking method:

1. Check the signal strength or check whether the screen is normal when the external device is connected.
2. After measuring each voltage from power supply, finally replace the MAIN BOARD.

Standard Repair Process Detail Technical Manual

LCD TV	Error symptom	A. Video error_Color error	Established date	2010. 12 .14	
	Content	Adjustment Test pattern - ADJ Key	Revised date		A12



- EZ ADJUST**
0. Tool Option1
 1. Tool Option2
 2. Tool Option3
 3. Tool Option4
 4. Tool Option5
 5. Tool Option6
 6. Tool Option7
 7. Country Group
 8. ADC Calibration
 9. White Balance
 10. 10 Point WB
 11. 20 Point WB
 12. Test Pattern
 13. Sub B/C
 14. Touch Sensitivity Setting
 15. Ext. Input Adjust

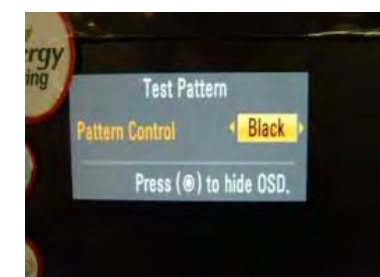
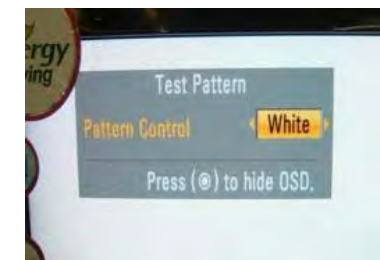

You can view 6 types of patterns using the ADJ Key

Checking item : 1. Defective pixel 2. Residual image 3. MODULE error (ADD-BAR,SCAN BAR..) 4.Video error (Classification of MODULE or Main-B/D!)

Appendix : Exchange T-Con Board (1)



Solder defect, CNT Broken



Solder defect, CNT Broken

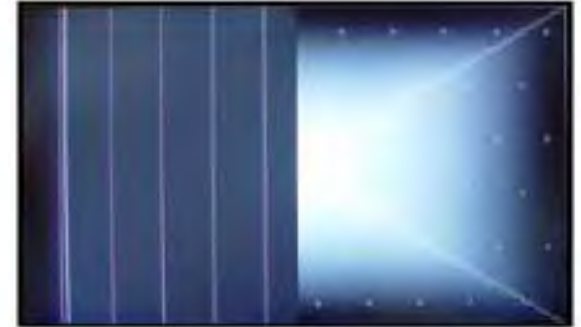

Solder defect, CNT Broken



Solder defect, CNT Broken

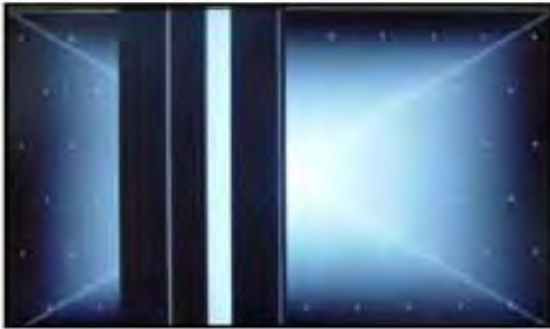

Solder defect, CNT Broken



Abnormal Power Section

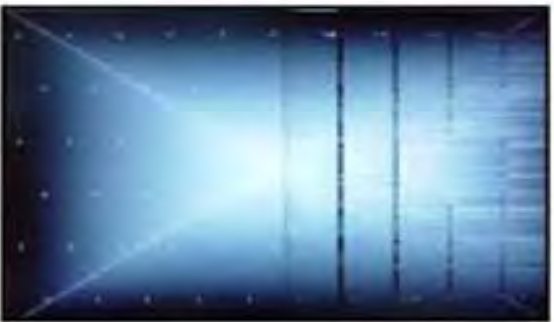

Solder defect, Short/Crack



Abnormal Power Section



Solder defect, Short/Crack

Appendix : Exchange T-Con Board (2)

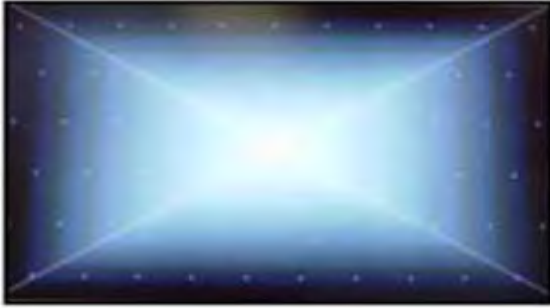

Abnormal Power Section



Abnormal Power Section



Solder defect, Short/Crack



Solder defect, Short/Crack



Fuse Open, Abnormal power section



Abnormal Display

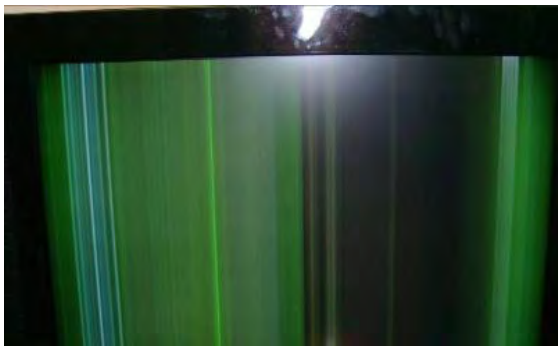

GRADATION



Noise



GRADATION

Appendix : Exchange PSU(LED driver)



No Light



Dim Light

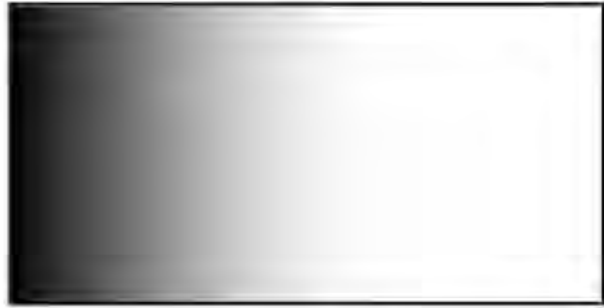

Dim Light

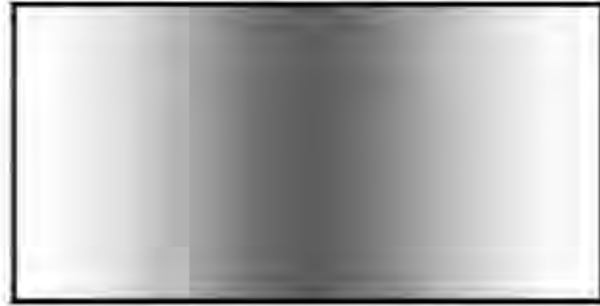

Dim Light



No picture/Sound Ok

Appendix : Exchange the Module (1)



Panel Mura, Light leakage



Panel Mura, Light leakage



Press damage

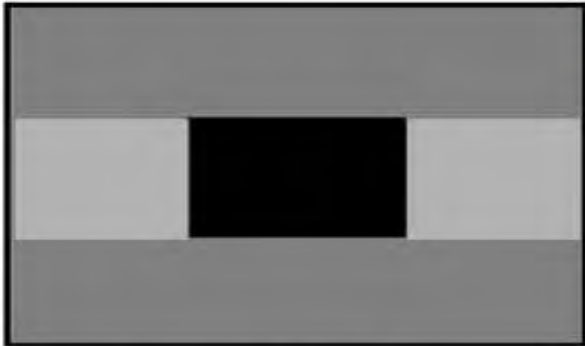

Crosstalk



Press damage

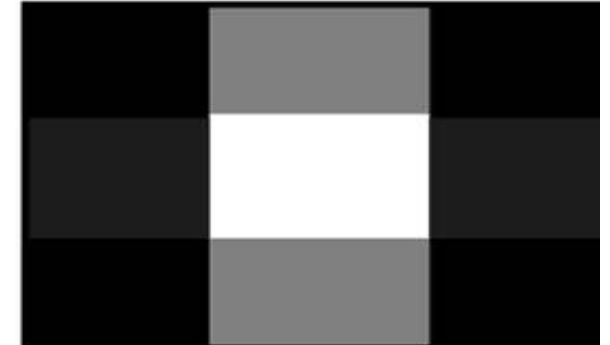

Crosstalk



Press damage

Un-repairable Cases

In this case please exchange the module.

Appendix : Exchange the Module (2)

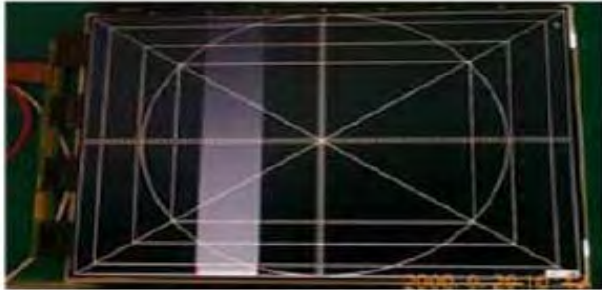

Vertical Block
Source TAB IC Defect



Vertical Line
Source TAB IC Defect



Vertical Block
Source TAB IC Defect



Horizontal Block
Gate TAB IC Defect



Horizontal Block
Gate TAB IC Defect



Horizontal line
Gate TAB IC Defect



Horizontal Block
Gate TAB IC Defect

Un-repairable Cases

In this case please exchange the module.

Standard Repair Process Detail Technical Manual

LCD TV	Error symptom	B. Power error _No power	Established date	2010. 12 .14	
	Content	Check front display LED	Revised date		A17

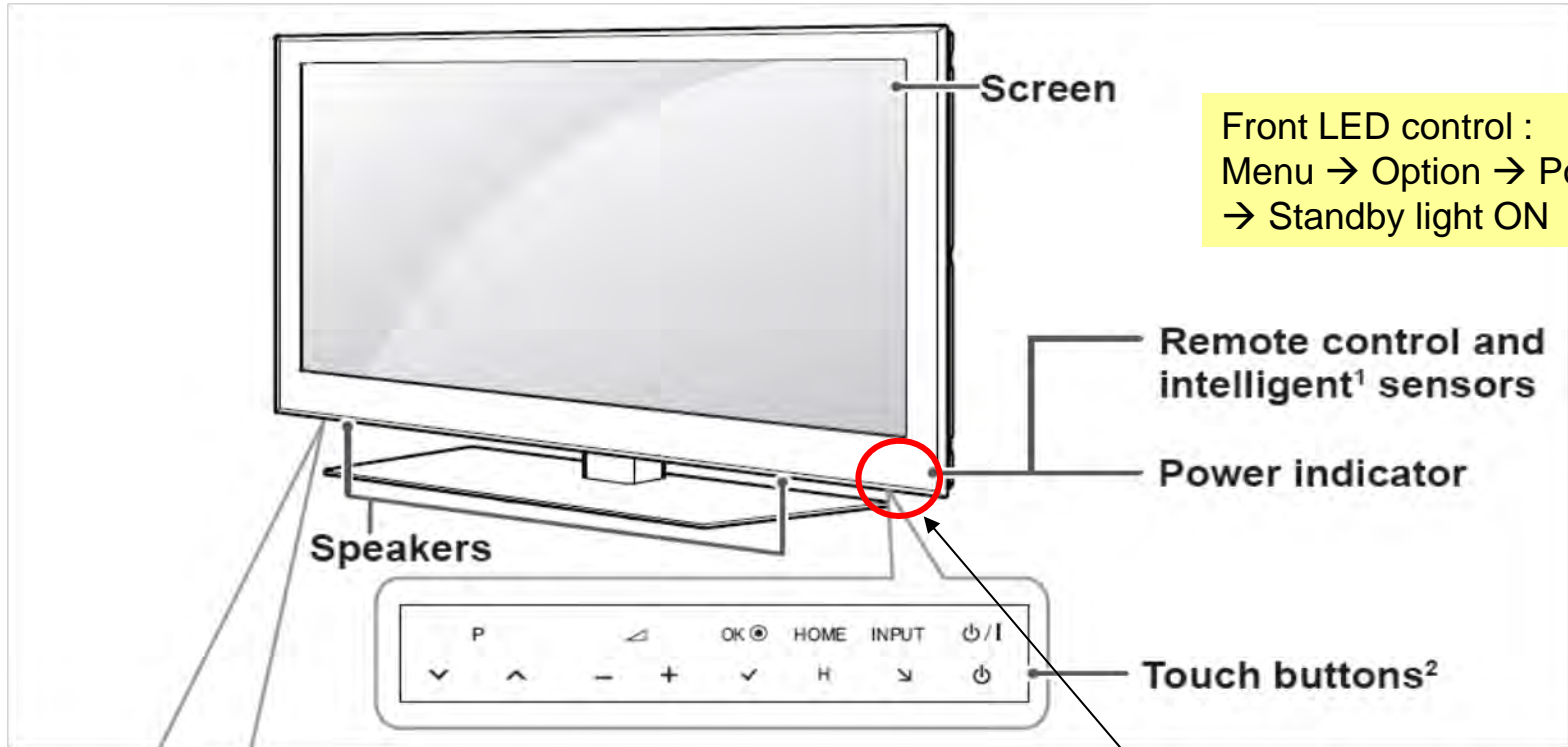

Front LED control :
Menu → Option → Power Indicator
→ Standby light ON

ST-BY condition: Red
Power ON condition: white

Standard Repair Process Detail Technical Manual

LCD TV	Error symptom	B. Power error _No power	Established date	2010. 12 .14	
	Content	Check power input voltage and ST-BY 5V	Revised date		A18

For '10 models, there is no voltage out for st-by purpose.
When st-by, only 3.5V is normally on.

Check the DC 20V/24V, 12V, 3.5V.

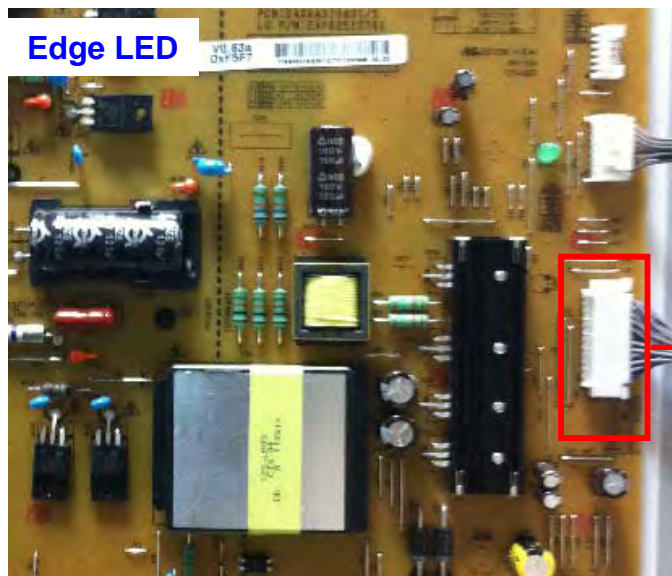

24 Pin (Power Board ↔ Main Board) – Common

SMAW200-H24S (YEONHO)

1	Power on	2	24V
3	24V	4	24V
5	GND	6	GND
7	GND	8	GND
9	3.5V	10	3.5V
11	3.5V	12	3.5V
13	GND	14	GND
15	GND	16	GND
17	12V	18	Inverter On/off
19	12V	20	Lamp : A-Dim LED : N.C
21	12V	22	PWM Dim #1
23	GND/P_DIM2 • Lamp SCANNING Model : PWM Dim #2	24	Error-out

Standard Repair Process Detail Technical Manual

LCD TV	Error symptom	B. Power error _No power	Established date	2010. 12 .14	
	Content	Checking method when power is ON	Revised date		A19

Check "power on" pin is high

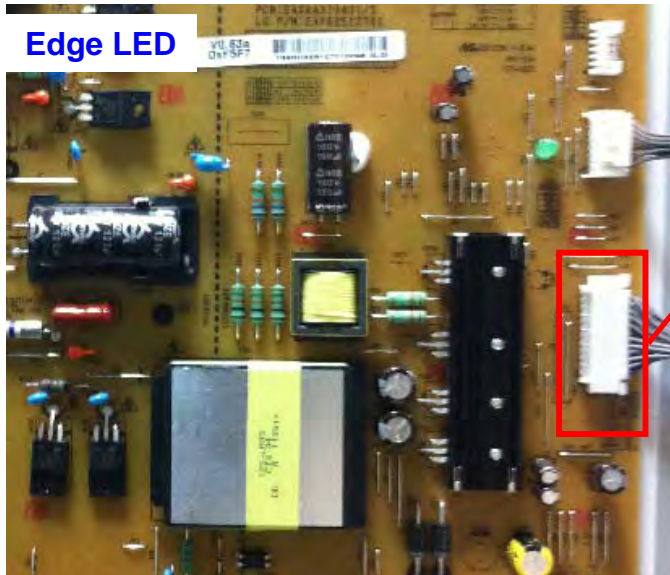

24 Pin (Power Board ↔ Main Board) – Common			
SMAW200-H24S (YEONHO)			
1	Power on	2	24V
3	24V	4	24V
5	GND	6	GND
7	GND	8	GND
9	3.5V	10	3.5V
11	3.5V	12	3.5V
13	GND	14	GND
15	GND	16	GND
17	12V	18	Inverter On/off
19	12V	20	Lamp : A-Dim LED : N.C
21	12V	22	PWM Dim #1
23	GND/P_DIM2 • Lamp SCANNING Model : PWM Dim #2	24	Error-out

Standard Repair Process Detail Technical Manual

LCD TV	Error symptom	B. Power error _Off when on, off whiling viewing	Established date	2010. 12 .14	
	Content	POWER OFF MODE checking method	Revised date		A22

<ALL MODELS>

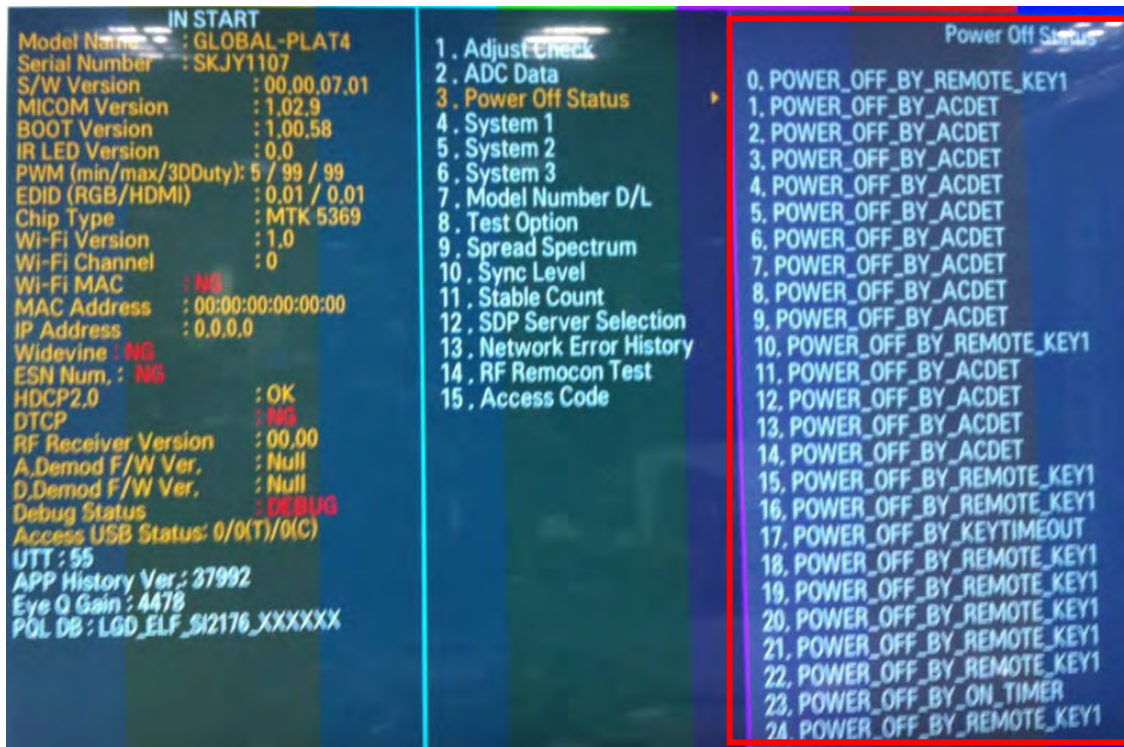

Entry method

1. Press the IN-START button of the remote controller for adjustment
2. Check the entry into adjustment item 3

Standard Repair Process Detail Technical Manual

LCD TV	Error symptom	C. Audio error_No audio/Normal video	Established date	2010. 12 .14	
	Content	Checking method in menu when there is no audio	Revised date		A24

<ALL MODELS>



Checking method

1. Press the MENU button on the remote controller
2. Select the AUDIO function of the Menu
3. Select TV Speaker from Off to On

Standard Repair Process Detail Technical Manual

LCD TV	Error symptom	C. Audio error_No audio/Normal video	Established date	2010. 12 .14	
	Content	Voltage and speaker checking method when there is no audio	Revised date		A25

<ALL MODELS>

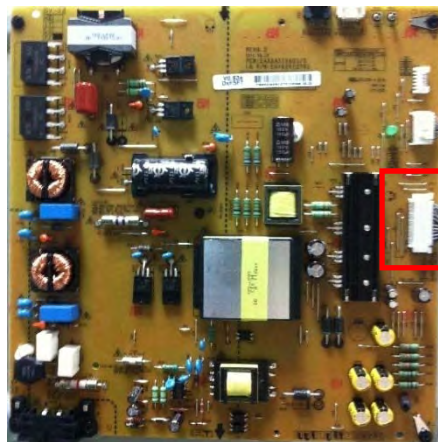

②

24 Pin (Power Board ↔ Main Board) – Common			
SMAW200-H24S (YEONHO)			
1	Power on	2	20V (24V)
3	20V (24V)	4	20V (24V)
5	GND	6	GND
7	GND	8	GND
9	3.5V	10	3.5V
11	3.5V	12	3.5V
13	GND	14	GND
15	GND	16	GND
17	12V	18	Inverter On/off
19	12V	20	Lamp : A-Dim LED : N.C
21	12V	22	PWM Dim #1
23	GND/P_DIM2	24	Error-out

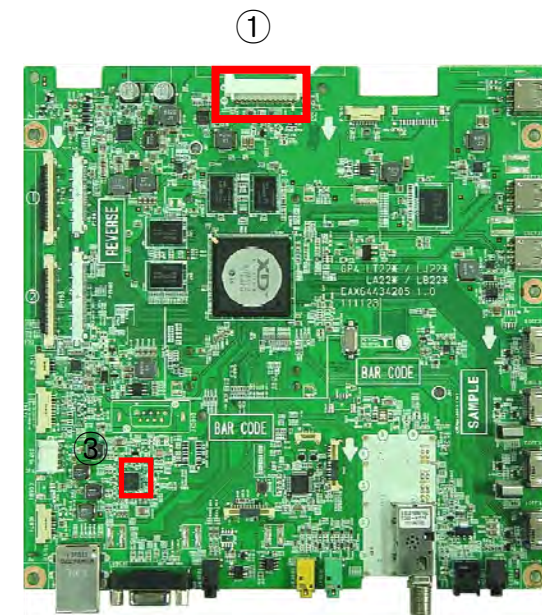

①

Checking order when there is no audio

① Check the contact condition of or 24V connector of Main Board

② Measure the 24V input voltage supplied from Power Board
(If there is no input voltage, remove and check the connector)

③ Connect the tester RX1 to the speaker terminal and if you hear the Chik Chik sound when you touch the GND and output terminal, the speaker is normal.

Standard Repair Process Detail Technical Manual

LCD TV	Error symptom	D. Function error_ No response in remote controller, key error	Established date	2010. 12 .14	
	Content	Remote controller operation checking method	Revised date		A27

<ALL MODELS>

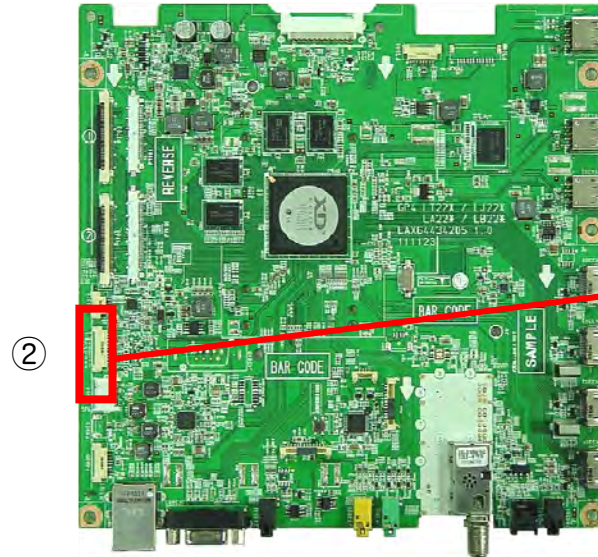
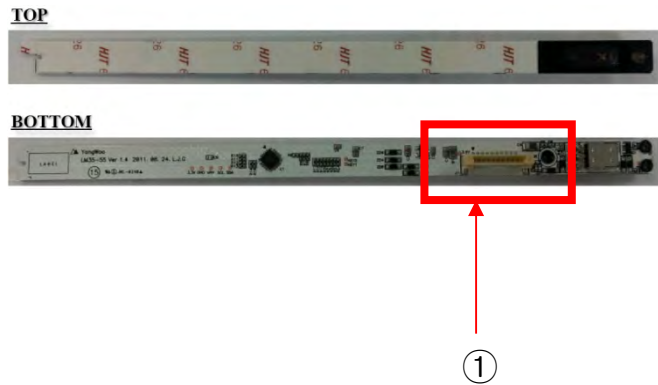

P4102	
1	SCL
2	SDA
3	GND
4	KEY1
5	KEY2
6	St 3.5V
7	GND
8	RED LED
9	IR
10	GND

④

Checking order

- 1, 2. Check IR cable condition between IR & Main board.
3. Check the st-by 3.3V on the terminal 6.
4. When checking the Pre-Amp when the power is in ON condition, it is normal when the Analog Tester needle moves slowly, and defective when it does not move at all.

Standard Repair Process Detail Technical Manual

LCD TV	Error symptom	D. VCOM Adjustment	Established date	2010. 12 .14	
	Content	Sequence of the Vcom adjustment	Revised date		A28

1. Case

- LCD module change
- T-Con board change

2. Equipment

- Service Remote controller

3. Adjust sequence

- Press the 'adj' key
- select V-COM
- As pushing the right or the left button on the remote controller, And find the V-COM value Which is no or minimized the Flicker.

(If there is no flicker at default value, Press the exit key and finish the VCOM adjustment.)

- Push the OK key to store the value. Then the message "Saving OK" is pop.
- Press the exit key to finish V-COM adjustment.

