

SERVICE MANUAL

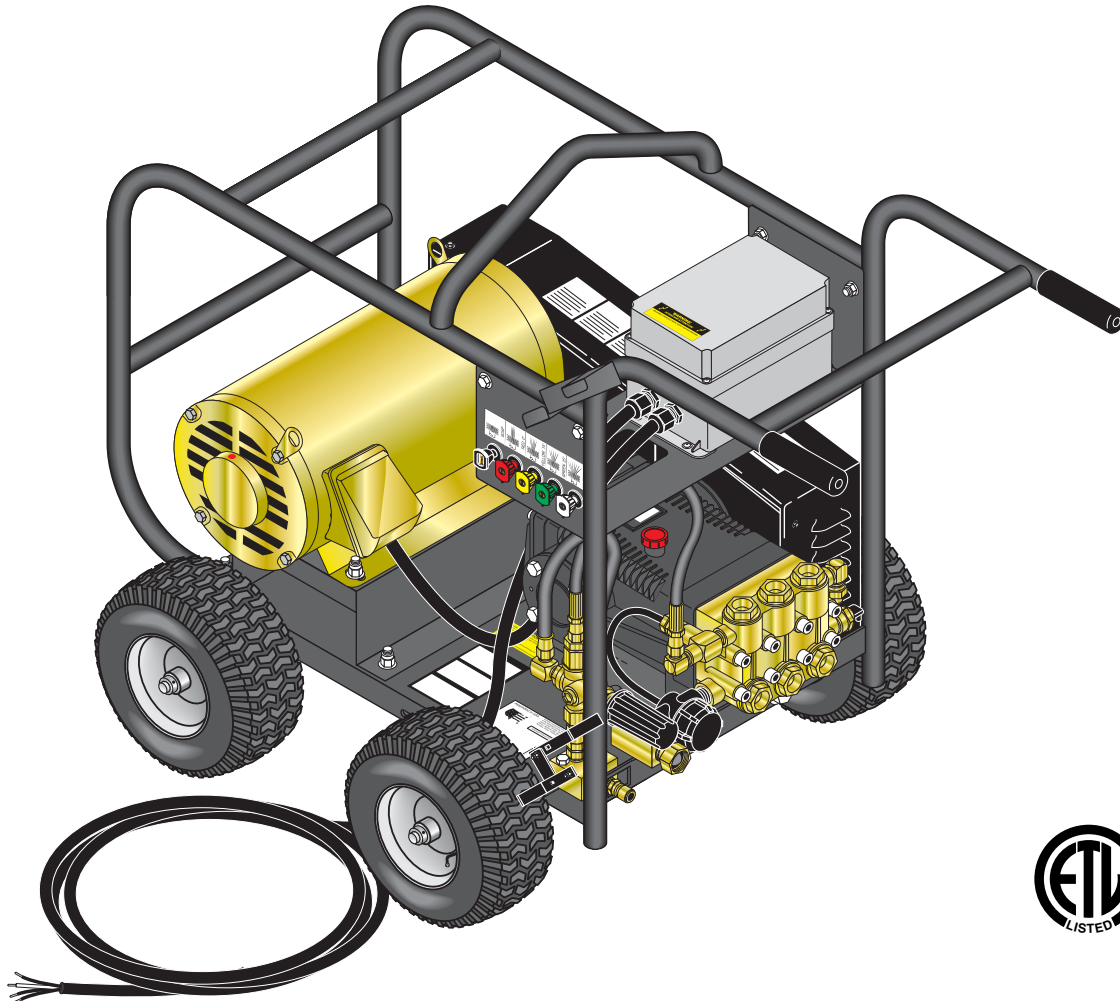

MODEL #	ORDER #
BDE-505009B	1.107-085.0
BDE-505009C	1.107-086.0
MPE5-50024B	1.106-001.0
MPE5-50024C	1.106-002.0
HD 5.0/50 Eb CAGE	1.107-084.0
HD 5.5/50 Ec CAGE	1.107-087.0
BRE-505007B	1.106-060.0
BRE-505007C	1.106-059.0

Exploded View	4
Exploded View, Parts List	5-6
Electrical Box Exploded View and Parts List	7
VBA Unloader	8
Hose & Spray Gun Assembly Troubleshooting	9
H Series Pump Exploded View and Parts List	10-11
Troubleshooting	12
230 VCA Electric Diagram	13
460 VCA Electric Diagram	14

Model Number _____

Serial Number _____

Date of Purchase _____

The model and serial numbers will be found on a decal attached to the pressure washer. You should record both serial number and date of purchase and keep in a safe place for future reference.

EXPLODED VIEW

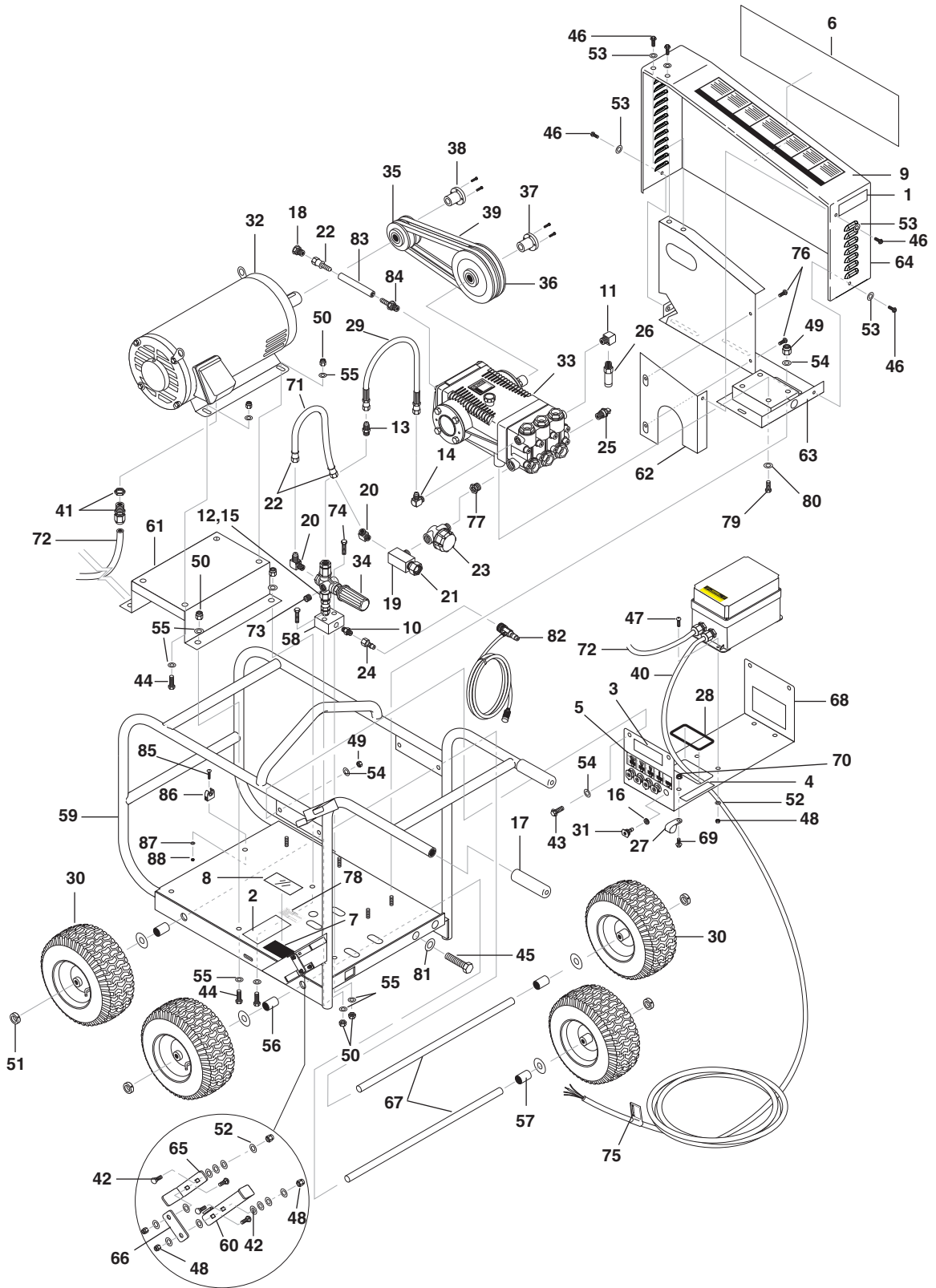

EXPLODED VIEW PARTS LIST

ITEM	PART NO.	DESCRIPTION	QTY	ITEM	PART NO.	DESCRIPTION	QTY
1	8.932-965.0	Label, Warning-Exposed Pulleys	1	31	9.803-810.0	Nozzle, SAQCMEG 0004.5, Red	1
2	9.803-842.0	Label, Operating Instr. (Lexan)	1		9.803-811.0	Nozzle, SAQCMEG 15045, Yellow	1
3	9.803-993.0	Label, Relieve Pressure	1		9.803-812.0	Nozzle, SAQCMEG 25045, Green	1
4	9.803-994.0	Label, Equipment Operated by Trained	1		9.803-813.0	Nozzle, SAQCMEG 4004.5, White	1
5	8.932-967.0	Label, Nozzle, 0, 15, 25, 40, & Soap	1		9.802-311.0	Nozzle Compl, QCEM-6540 Brass	1
6	8.750-465.0	Label, MVC Frame, Logo	1	32	8.751-012.0	Motor, 20HP, 3Ph, 230/460V 1800 Rpm, EM251	1
	8.901-144.0	Label, Logo, Belt Guard, BD	1		9.800-040.0	▲ Label, Ground (Motor)	1
	9.800-047.0	Label, Belt Guard, HD	1		9.802-487.0	▲ Wire Nut, Brown (230V/3PH)	6
	8.900-870.0	Label, Logo, BR	1				
7	9.800-013.0	Label, Intended For Indoor Use	1	33	8.749-518.0	Pump, Landa LH5050/R, 5@5000, 1650 RPM	1
8	9.800-034.0	Label, Clear Lexan, 2-1/4" x 4-1/2"	1		8.749-519.0	Pump, Hotsy, HH5050/R, 5@5000, 1650 RPM	1
9	9.800-036.0	Label, Warning, Pictorial, Small	1		9.804-491.0	Pump, Kärcher KH5050/R 5@5000, 1650 RPM	1
10	9.802-011.0	Nipple, 3/8" Hex Steel	1	34	9.802-360.0	Unloader, PA 10.5 GPM @ 5100PSI, VB350/4	1
11	9.802-030.0	Elbow, 3/8" Street, Female	1	35	9.802-394.0	Pulley, 3TB40	1
12	9.802-036.0	Nipple, 1/2" JIC, 3/8" Pipe	1	36	9.803-979.0	Pulley, 3BK 50 H	1
13	9.802-037.0	Nipple, 1/2" JIC, 3/8" Female	1	37	9.802-403.0	Bushing, H x 25MM	1
14	9.802-039.0	Elbow, 1/2" JIC, 3/8", 90°	1	38	9.803-980.0	Bushing, P1 x 1-5/8"	1
15	9.802-048.0	Swivel, 1/2" JIC Fem, 3/8" Male	1	39	8.749-965.0	Belt, 3/BX 42	1
16	9.802-064.0	Grommet, Rubber, Nozzle Holder	5	40	9.803-992.0	Cord, Service, SO, 4/4 (230V/3PH)	15 ft
17	9.802-070.0	Grip, 1" Sqr, Handle,	2		9.802-437.0	Cord, Serv, SEO 10/4, Coleman (460V)	15 ft
18	9.802-126.0	Plug 1/2" JIC	1	41	9.804-052.0	Connector, 1" Cord, 50 Amp (230V/3PH)	1
19	9.802-118.0	Tee, 1/2" Branch Male	1		9.803-279.0	Strain Relief, 1", 460V	1
20	9.802-131.0	Elbow, 1/2" JIC x 1/2", 90°	2		9.803-280.0	Locknut, 1"	1
21	9.802-146.0	Swivel, 1/2" MP x 3/4" GHF w/Strainer	1	42	9.802-705.0	Bolt, Carriage, Zinc, 1/4-20 x 1.0 PLT	4
22	9.802-151.0	Swivel, 1/2" JIC Fem, Push-On	2	43	9.802-722.0	Bolt, 5/16" x 1", NC HH	4
23	9.802-163.0	Strainer, 1/2" PA, Inline Plastic	1	44	9.802-720.0	Bolt, 3/8" x 1", NC HH	8
24	9.802-168.0	Nipple, 3/8" Fem, 11,000 Psi	1	45	9.803-845.0	Bolt, 1/2" x 5" NC HH TAP, All Thread	1
25	9.802-182.0	Pump Protector, 1/2" Ptp	1	46	9.802-765.0	Screw, 1/4" x 1/2" BH SOC	5
26	9.803-843.0	Valve, Safety Relief, 6000 Psi	1	47	9.802-770.0	Screw, 1/4" x 1", BH SOC	4
27	9.802-204.0	Clamp, Hose (460V)	1	48	9.802-773.0	Nut, 1/4" ESNA, NC	8
	9.802-206.0	Clamp, Hose (230V)	1	49	9.802-776.0	Nut, 5/16", ESNA, NC	8
28	9.802-071.0	Trim, 750 x 1/16", Black	1.66 ft.	50	9.197-003.0	Nut, 3/8", ESNA, NC	10
29	8.918-421.0	Hose, 3/8" x 14", 2 Wire, Pressure Loop	1	51	9.802-782.0	Collar, 5/8" Bore Shaft	8
30	9.802-271.0	Wheel & Tire Assy, 6" Steel Rim w/Tube	4	52	9.802-802.0	Washer, 1/4" Flat, SAE	16

▲ Not Shown

EXPLODED VIEW PARTS LIST

ITEM	PART NO.	DESCRIPTION	QTY	ITEM	PART NO.	DESCRIPTION	QTY
53	9.802-803.0	Washer, 1/4" Flat, SAE, Black Zinc	5	71	9.802-259.0	Hose, 1/2" Push-On	15"
54	9.802-804.0	Washer, 5/16" Flat, SAE	12	72	9.803-992.0	Cord, Service 4/4 (230V/3PH)	37"
55	9.802-807.0	Washer, 3/8" SAE, Flat	16		9.802-437.0	Cord, Service 10/4 (460V/3PH)	37"
56	9.802-810.0	Washer, 5/8" Flat, SAE	8	73	9.802-124.0	Plug, 1/4" Countersunk	1
57	9.802-820.0	Washer, Nylon Spacer, 0.656 x 1.25 x 0.65	4	74	9.802-728.0	Bolt, 3/8" x 2"	2
58	9.802-870.0	Block, Unloader, 3/8" x 3/8", 1.25, Steel	1	75	8.932-969.0	Label, Warning, Service Cord	1
59	9.802-964.0	Assy, Weld, Cage, CW Black	1	76	9.802-765.0	Screw, 1/4" x 1/2" BH SOC CS	2
	8.912-486.0	Assy, Weld, Cage, CW Red	1	77	9.802-148.0	Adaptor, 1/2" x 1/2"	1
60	9.802-966.0	Handle, Brake, CW Cage, Black	1	78	9.800-049.0	Label, Manufacturer's Cleaning Solution	1
	8.912-495.0	Handle, Brake, CW Cage Red	1	79	9.802-744.0	Bolt, 10mm x 20mm, HH	4
61	9.804-008.0	Assy, Weld, Motor Rail, Elec, CW Large, Black	1	80	9.802-816.0	Washer, 7/16", Lock Split Ring	4
	8.917-411.0	Assy, Weld, Motor Rail, Elec, CW Large, Red	1	81	9.802-809.0	Washer, 1/2"	1
62	9.804-009.0	Assy, Weld, Elec, Guard Rear, CW Large	1	82	9.802-226.0	Assy, Downstream Injector	1
63	9.804-010.0	Assy, Weld, Slider, Elec, CW Large, Black	1	83	9.802-259.0	Hose, 1/2" Push-On	20"
	8.917-412.0	Assy, Weld, Slider, Elec, CW Large, Red	1	84	9.802-156.0	Push-On 1/2" x 3/8"	1
64	9.804-011.0	Guard, Belt, Front, Elec, CW Large	1	85	9.802-771.0	Screw 10/32"	1
65	9.802-996.0	Bracket, Brake Pad, Black	1	86	9.802-203.0	Clamp 1/2"	1
	8.912-019.0	Bracket, Brake Pad, Red	1	87	9.802-802.0	Washer	1
66	9.802-997.0	Linkage, Brake, Black	1	88	9.804-567.0	Nut 10/32"	1
	8.912-020.0	Linkage, Brake, Red	1				
67	8.918-839.0	Axle, Lrg, Cw Cage 31.25"	2				
68	9.804-012.0	Bracket, E-Box, CW Cage, Large, Black	1				
	8.917-493.0	Bracket, E-Box, CW Cage Large, Red	1				
69	9.802-759.0	Screw, 10/32" x 1/2" Bhsoc (460V/3PH)	1				
	9.802-770.0	Screw, 1/4" x 1", Bh Soc Cs (230V/3PH)	1				
70	9.802-695.0	Nut, 10/32" Keps 460V/3Ph	1				
	9.802-773.0	Nut, 1/4" ESNA, Nc (230V/3PH)	1				

EXPLODED VIEW - ELECTRICAL BOX

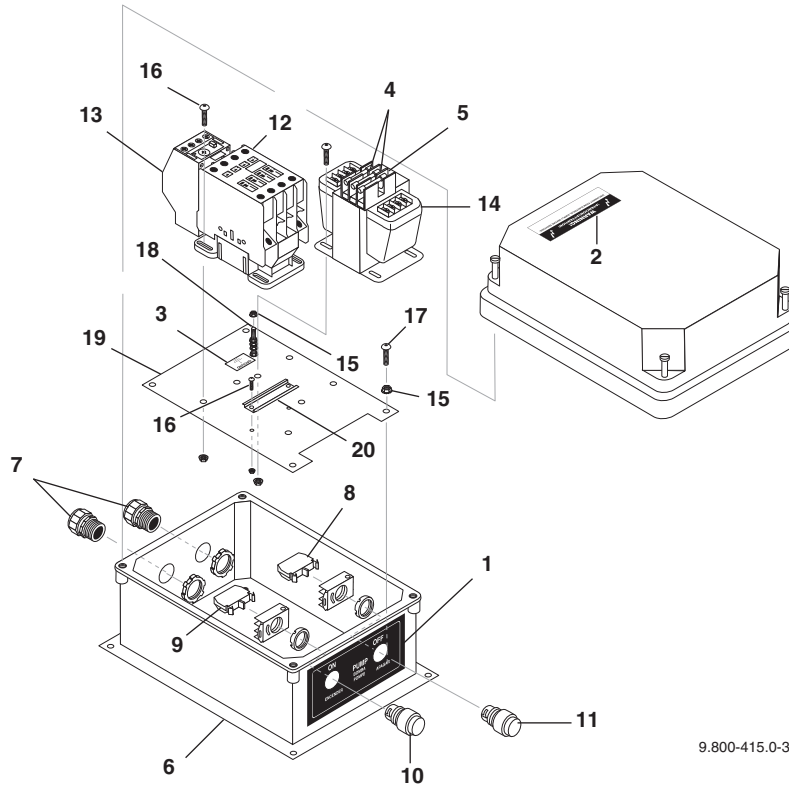

ELECTRICAL BOX PARTS LIST

ITEM	PART NO.	DESCRIPTION	QTY	ITEM	PART NO.	DESCRIPTION	QTY
1	8.900-315.0	Label, On/Off, PE Push Buttons	1	10	9.803-974.0	Switch, Green PB, CH E22PB3	1
2	9.800-016.0	Label, Disconnect Power Supply	1	11	9.803-973.0	Switch, Red PB, CH E22EB2	1
3	9.800-040.0	Label, Ground	1	12	8.724-284.0	Contact 1 (230V/3PH)	1
4	8.933-007.0	Fuse, KTK-R1 600V Midget Fuse (230V/3PH)	2	13	8.724-281.0	Contact 2 (460V/3PH)	1
	9.802-462.0	Fuse, KTK-R-1/2 600V Midget Fuse (460V/3PH)	2	13	8.724-307.0	Overload (230V/3PH)	1
5	9.802-463.0	Fuse, Paper, Buss FNM-1/2, 250V Midget TD	1	13	8.724-305.0	Overload (460V/3PH)	1
6	9.803-976.0	Box, Plastic, 10X8X6.19, RVJ1008W	1	14	9.802-551.0	Transformer, Micron, 240/480V-120V,50/60HZ,.050KVA	1
7	9.804-052.0	Connector, 1" Cord, 50 Amp (5-50024B)	2	15	9.802-695.0	Nut, 10/32" Keps	7
	9.803-280.0	Locknut, 1" Cond. (230V/3PH)	2	16	9.802-750.0	Screw, 8-32 x 1/2" M TPG PH PNH, Black	7
	9.802-518.0	Strain Relief, 3/4" (460V/3PH)	2	17	9.802-759.0	Screw, 10/32" x 1/2" BHSOC Black	4
	9.802-526.0	Locknut, 3/4" Conduit (460V/3PH)	2	18	9.802-762.0	Screw, 10/32" x 11/4" RH, SL, Black	1
8	9.802-534.0	Block, Contact, N/C, CH E22B1	1	19	9.803-990.0	Standoff, CW Cage, Lrg. MPE1	1
9	9.802-535.0	Block, Contact, N/O, CH E22B2	1	20	9.802-457.0	Din Rail, 35mm	3"

VB UNLOADER EXPLODED VIEW

9.802-360.0
VB350/4 10.5 GPM at 5100 PSI

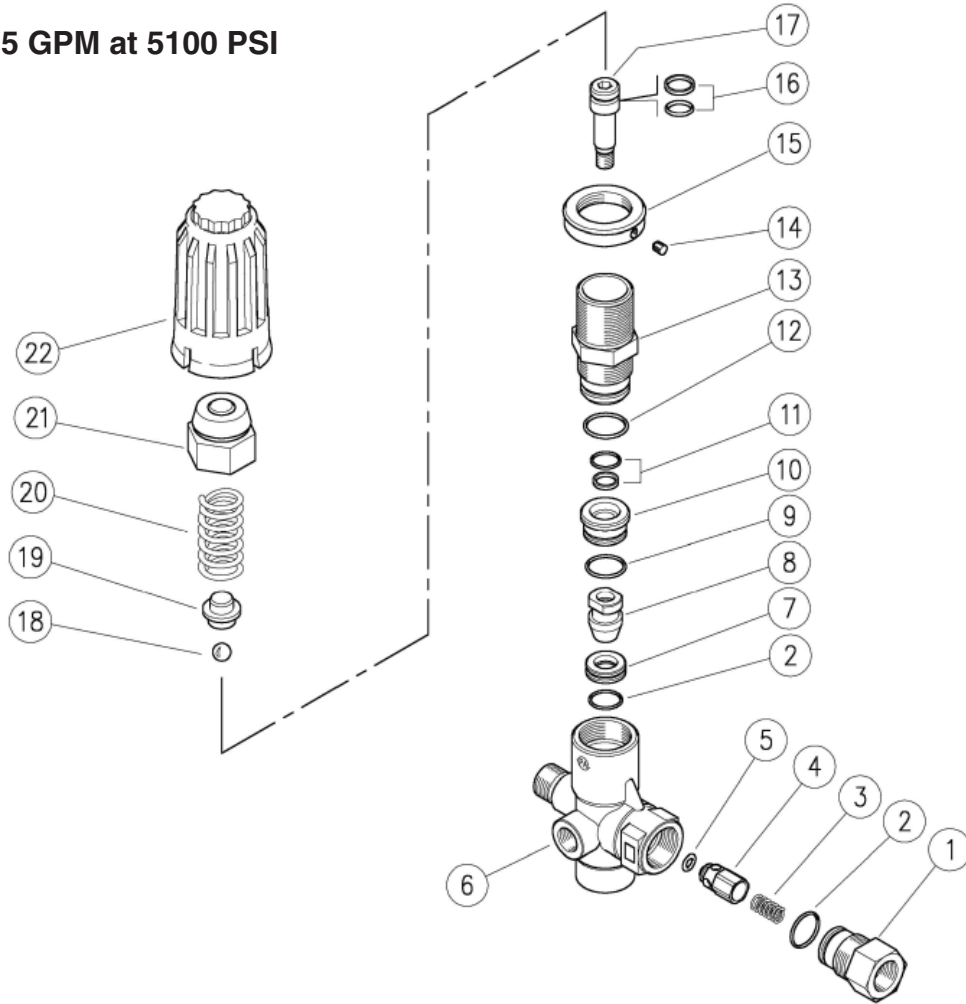

VB UNLOADER EXPLODED VIEW PARTS LIST

ITEM	PART #	DESCRIPTION	QTY	ITEM	PART #	DESCRIPTION	QTY
1		3/8 Bsp F Nipple	1	16	*	VB280-350 Val. Pist. Seal	1
2	*	O-Ring, 1.78 x 15.6 mm	2	17		M8 Piston	1
3		Spring	1	18	*	Sst 11/32" Ball	1
4		SST Check Valve	1	19		Spring Guide	1
5	*	O-Ring, 3 x 6mm	1	20		4.5 x 47 mm Spring (60.1700.00)	1
6		VB280-350 Brass Body	1	21		Brass Cap	1
7	*	Seat	1	22		VB350.4 Red Plastic Knob (60.1700.00)	1
8	*	M 8 Shutter	1				
9	*	O-Ring, 1.78 x 17.17 mm	1				
10		Spacer	1				
11	*	VB280-350 Val. Pist. Seal	1				
12	*	O-Ring, 1.78 x 20.35 mm	1				
13		Piston Housing (60.1700.00)	1				
14		M 4 x 4 mm Dowel	1				
15		Lock Nut	1				

* Available in Repair Kit :

K1 9.800-106.0 VB350 Repair Kit

HOSE & SPRAY GUN ASSEMBLY

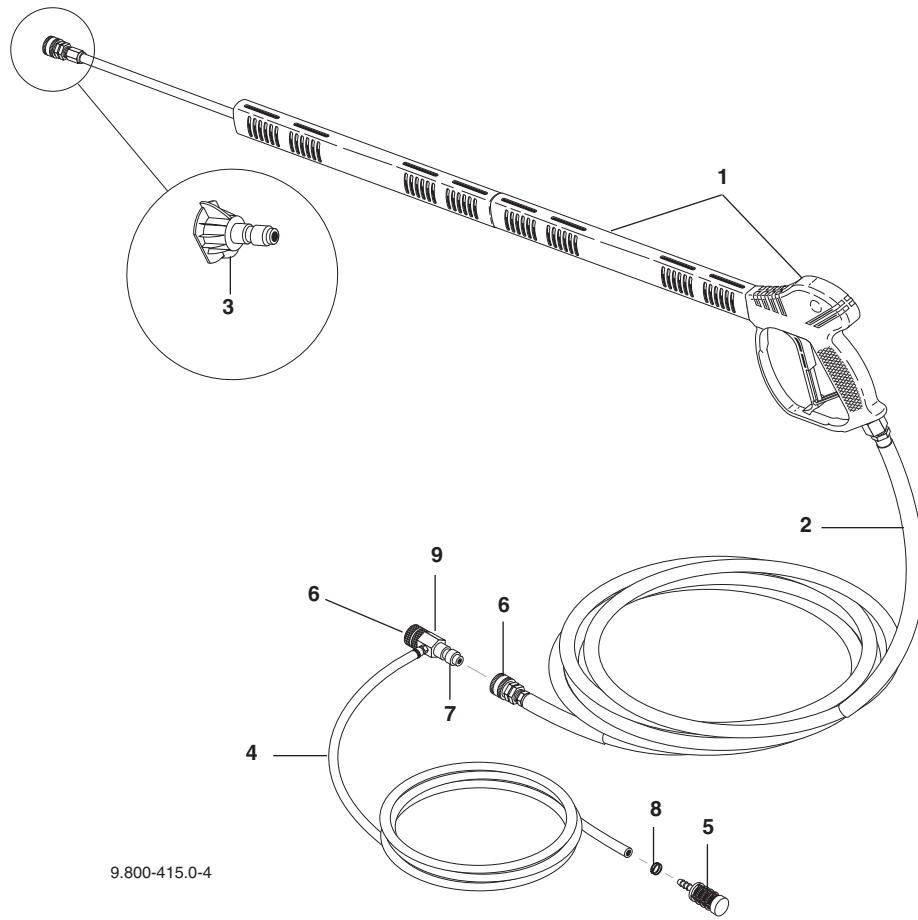

HOSE & SPRAY GUN ASSEMBLY PARTS LIST

ITEM	PART NO.	DESCRIPTION	QTY	ITEM	PART NO.	DESCRIPTION	QTY
1	9.802-228.0	Gun w/Wand (5000 PSI), w/Coupler	1	4	9.802-251.0	Hose, 1/4" x 1/2" Clear Vinyl	6 ft.
2	8.739-346.0	Hose, 3/8" x 50', 2 Wire, TS KA, SO-SW HP CP (BRE, HD)	1	5	9.802-160.0	Strainer, Plastic, 1/4" Hose Barb	1
	8.918-088.0	Hose, 3/8" x 50', 2W,TS,SO-SW HIGH PRESS CP (MPE)	1	6	9.802-167.0	Coupler, 3/8" Fem, 11,000 PSI, Snap-Tite	1
	8.739-322.0	Hose, 3/8" x 50' 2W TS, HO, SO-SW, HP CP (BDE)	1	7	9.802-168.0	Nipple, 3/8" Fem, 11,000 PSI	1
3	9.803-810.0	Nozzle, SAQCMEG 0004.5, Red	1	8	6.390-126.0	Clamp, Hose, .46-.54 ST	2
	9.803-811.0	Nozzle, SAQCMEG 15045, Yellow	1	9	9.802-167.0	Injector, SS, Non Adj, 2.0-4.0 GPM, 5500 PSI	1
	9.803-812.0	Nozzle, SAQCMEG 25045, Green	1				
	9.803-813.0	Nozzle, SAQCMEG 4004.5, White	1				
	9.802-311.0	Nozzle COMPL, QCEM-6540 Brass	1				

H-SERIES PUMP EXPLODED VIEW

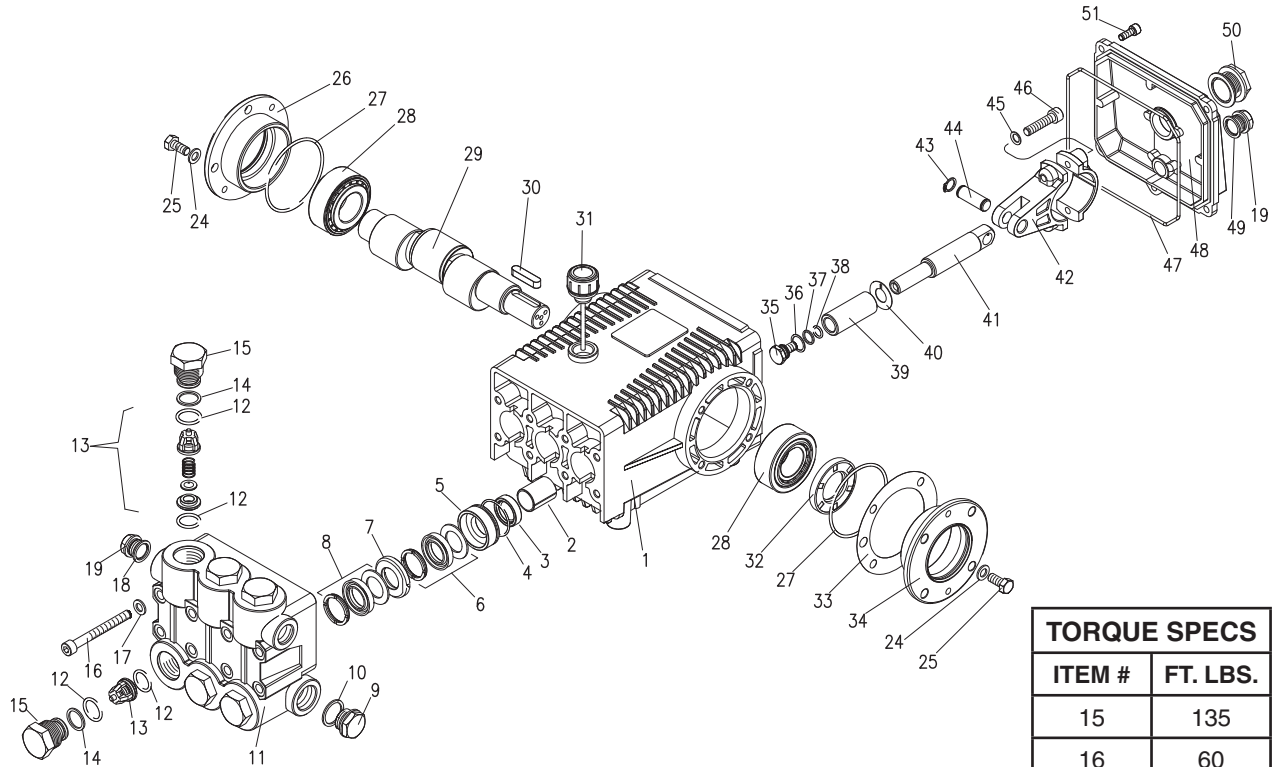

TORQUE SPECS	
ITEM #	FT. LBS.
15	135
16	60
25	18
35	4.5
46	30
51	7.6

H-SERIES PUMP EXPLODED VIEW PARTS LIST

ITEM	PART NO.	DESCRIPTION	QTY	ITEM	PART NO.	DESCRIPTION	QTY
1	9.803-163.0	Crankcase	1	17	9.802-890.0	Lock Washer	8
2	9.803-195.0	Plunger Guide	3	18	9.803-198.0	Copper Washer 3/8	1
3*	See Kit Below	Plunger Oil Seal	3	19	9.802-925.0	Brass Plug 3/8	2
4*	See Kits Below	O-Ring Ø1.78 x 37.82	3	24	9.802-884.0	Washer	8
5*	See Kits Below	Pressure Ring 18mm	3	25	9.802-944.0	Hex Screw	8
6*	See Kit Below	U Seal, Dia. 18 x 28mm	3	26	9.804-501.0	Closed Bearing Housing	1
7*	See Kits Below	Support Ring 18mm	3	27	9.803-186.0	O-Ring Ø2.62 x 71.12	2
8*	See Kits Below	U Seal, Dia 18 x 28mm	3	28	9.804-502.0	Roller Bearing	2
9	9.802-926.0	Brass Plug, 1/2	1	29	9.803-289.0	Crankshaft	1
10	9.803-199.0	Copper Washer 1/2	1	30	9.803-293.0	Crankshaft Key	1
11	8.717-516.0	Manifold Housing	1	31	9.802-923.0	Oil Dip Stick	1
12*	9.804-498.0	O-Ring Ø2.62 x 17.13	12	32	9.803-139.0	Crankshaft Seal	1
13*	See Kit Below	Valve Assembly	6	33	9.803-177.0	Shim	2
14*	9.804-500.0	Teflon Ring	6	34	9.804-503.0	Bearing Housing	1
15	9.803-292.0	Valve Plug	6	35*	9.802-936.0	Plunger Bolt	3
16	9.802-942.0	Manifold Stud Bolt	8	36*	9.802-885.0	Copper Spacer	3

H-SERIES PUMP EXPLODED VIEW PARTS LIST

ITEM	PART NO.	DESCRIPTION	QTY
37*	9.803-188.0	O-Ring Ø1.78x7.66	3
38*	9.803-155.0	Teflon Ring	3
39*	See Kit Below	Plunger 18mm	3
40*	9.802-888.0	Copper Spacer	3
41	9.803-294.0	Plunger Rod	3
42	9.803-157.0	Connecting Rod	3
43	9.802-912.0	Snap Ring	6
44	9.802-915.0	Connecting Rod Pin	3
45	9.802-889.0	Spring Washer	6
46	9.802-937.0	Connecting Rod Screw	6
47	9.803-194.0	O-Ring Ø2.62 x 152.07	1
48	9.803-166.0	Crankcase Cover	1
49	9.803-197.0	Gasket, G3/8	1
50	9.803-202.0	Sight Glass G3/4	1
51	9.802-939.0	Cover Screw	5

* Available in kit (See below)

KIT NUMBERS	9.804-492.0	9.804-493.0	9.802-629.0	9.802-604.0	9.802-606.0
KIT DESCRIPTION	Plunger Seal 18 mm	Seal Packing 18 mm	Plunger 18 mm	Complete Valve	Plunger Oil Seals
ITEMS NUMBERS INCLUDED	4, 6, 8	4, 5, 6, 7, 8	35, 36, 37, 38, 39, 40	12, 13, 14	3
NUMBER OF CYLINDERS KIT WILL SERVICE	3	1	1	6	3

TROUBLESHOOTING

PROBLEM	POSSIBLE CAUSE	SOLUTION
PUMP RUNNING NORMALLY BUT PRESSURE LOW ON INSTALLATION	Pump sucking air	Check water supply and possibility of air seepage.
	Check valves sticking	Check and clean or replace if necessary.
	Unloader valve seat faulty	Check and replace if necessary.
	Nozzle incorrectly sized	Check and replace if necessary.
	Worn piston packing	Check and replace if necessary.
FLUCTUATING PRESSURE	Valves worn	Check and replace if necessary.
	Blockage in valve	Check and clean out if necessary.
	Faulty or misadjusted unloader valve	Tampering with the factory setting may cause personal injury and/or property damage, and will void the manufacturer's warranty.
	Pump sucking air	Check water supply connections.
	Worn piston packing	Check and replace if necessary.
	Insufficient water	Check filter and hose for breakage.
PRESSURE LOW AFTER PERIOD OF NORMAL USE	Nozzle worn	Check and replace if necessary.
	Suction or delivery valves worn	Check and replace if necessary.
	Suction or delivery valves blocked	Check and clean if necessary.
	Unloader valve seat worn	Check and replace if necessary.
	Worn piston package	Check and replace if necessary.
PUMP NOISY	Air in suction line	Check water supply and connections on suction line.
	Broken or weak suction or delivery valve spring	Check and replace if necessary.
	Foreign matter in valves	Check and clean if necessary.
	Worn bearings	Check and replace if necessary.
	Excessive temperature of water	Reduce to below 140°F.
PRESENCE OF WATER IN PUMP OIL	Oil seal worn	Check and replace if necessary.
	High humidity in air	Check and change oil twice as often.
	Piston packing worn	Check and replace if necessary.
WATER DRIPPING FROM UNDER PUMP	Piston packing worn	Check and replace if necessary.
	O-Ring plunger retainer worn	Check and replace if necessary.
WATER DRIPPING FROM PUMP PROTECTOR	Water supply pressure too high (over 90 psi)	Lower water supply pressure using a regulator.
	Spray gun is in the off position for over 1-2 minutes	Turn machine off if not in use for over 1-2 minutes.
OIL DRIPPING	Oil seal worn	Check and replace if necessary.
EXCESSIVE VIBRATION IN HIGH-PRESSURE HOSE	Irregular functioning of the pump valves	Check and replace if necessary

230 VCA ELECTRIC DIAGRAM

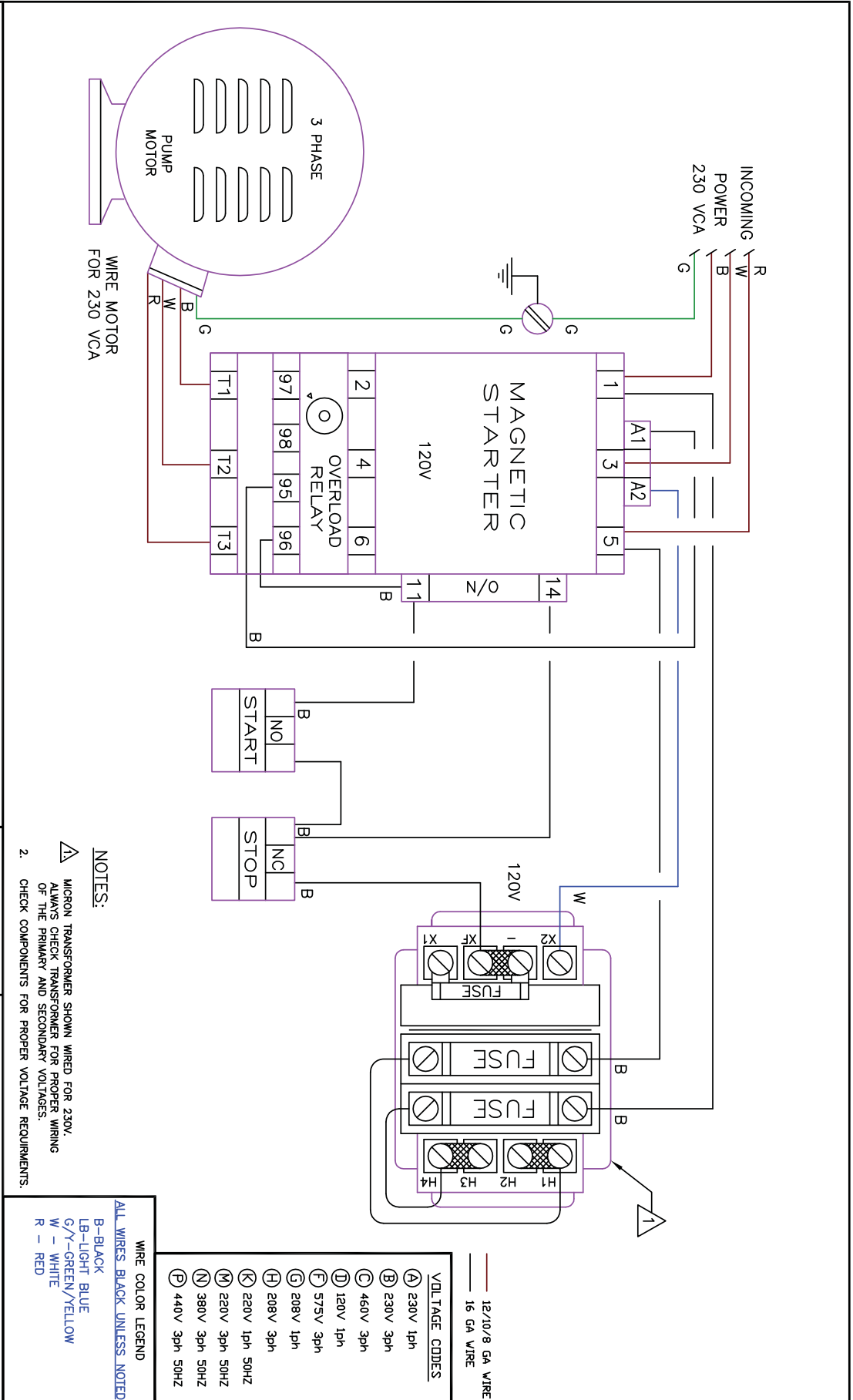

460 VCA ELECTRIC DIAGRAM

