



STUDIO
Conventional Flue
**Instructions for Use,
Installation and Servicing**
For use in GB, IE (Great Britain and Eire)

This appliance has been certified for use in countries other than those stated. To install this appliance in these countries, it is essential to obtain the translated instructions and in some cases the appliance will require modification. Contact Gazco for further information.

IMPORTANT

Do not attempt to burn rubbish in this appliance. This appliance must only be operated with the glass door secured firmly in position. The front casing of this appliance will become hot whilst in operation, it is therefore recommended that a suitable guard should be used for the protection of young children, the elderly or infirm.

These instructions must be left at the property for future reference and when servicing the fire.

The Commissioning Sheet found on page 3 must be completed by the Corgi Installer.

COVERING THE FOLLOWING MODEL:
STUDIO 1 CONVENTIONAL FLUE:
8700CFCHEC 8701CFCHEC
P8700CFCHEC P8701CFCHEC

	PAGE
APPLIANCE COMMISSIONING CHECKLIST	3
USER INSTRUCTIONS	4
INSTALLATION INSTRUCTIONS	8
Technical Specifications	8
Site Requirements	11
Installation	13
Commissioning	22
SERVICING INSTRUCTIONS	23
Fault Finding	23
How to replace parts	25
Basic spare parts list	31
Service Records	32

APPLIANCE COMMISSIONING CHECKLIST

IMPORTANT NOTICE

Explain the operation of the appliance to the end user, hand the completed instructions to them for safe keeping, as the information will be required when making any guaranteed claims.

FLUE CHECK	PASS	FAIL
1. Flue is correct for appliance		
2. Flue flow test		
3. Spillage test		
GAS CHECK		
1. Gas soundness & let by test		
2. Standing pressure test	mb	
3. Appliance working pressure (on High Setting) NB All other gas appliances must be operating on full	mb	
4. Gas rate	m ³ /h	
5. Does ventilation meet appliance requirements		

DEALER AND INSTALLER INFORMATION

Dealer

Installation Company

Contact No.

Engineer

Date of Purchase

Contact No.

Model No.

Corgi Reg No.

Serial No.

Date of Installation

Gas Type

This product is guaranteed for 2 years from the date of installation, as set out in the terms and conditions of sale between Gazco and your local Gazco dealer. **This guarantee will be invalid, to the extent permitted by law, if the above Appliance Commissioning Checklist is not fully completed by the installer and available for inspection by a Gazco engineer.** The guarantee will only be valid during the second year, to the extent permitted by law, if the annual service recommended in the Instructions for Use has been completed by a Corgi registered engineer, and a copy of the service visit report is available for inspection by a Gazco engineer.

USER INSTRUCTIONS

1. GENERAL

- 1.1 A competent person must carry out installation and servicing.
- 1.2 In all correspondence, please quote the appliance type and serial number, which can be found on the data badge located on a plate inside the controls compartment
- 1.3 **Do not** place curtains above the fire:
You must have 300mm (1') clearance between the fire and any curtains at either side.
- 1.4 If any cracks appear in the glass panel do not use the appliance until the panel has been replaced.
- 1.5 In the unlikely event the appliance is receiving interference from other electronic devices, the handset/Control box can be re-programmed. Please consult your dealer if you think this may be the case.
- 1.6 This product is guaranteed for 2 years from the date of installation, as set out in the terms and conditions of sale between Gazco and your local Gazco dealer. Please consult with your local Gazco dealer if you have any questions. In all correspondence always quote the Model Number and Serial Number.

2. LIGHTING THE STUDIO

There are two ways of lighting the Studio:

- by thermostatic remote control, see 2A
- using the fire's touch pad, see 2B

2A - THERMOSTATIC and TIMER REMOTE CONTROL

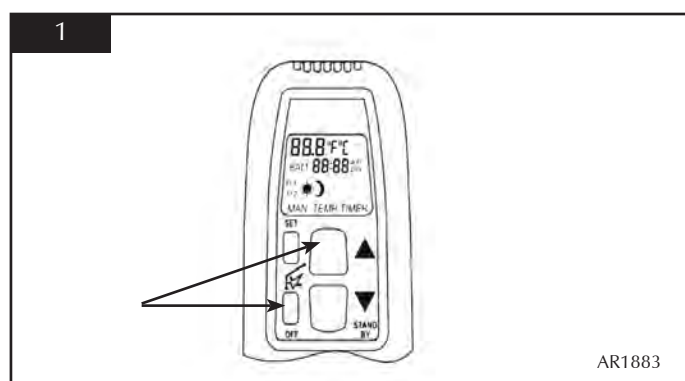

Turning the Studio On

Your remote can control the gas fire from pilot ignition through to shut down.

To turn the fire on:

- Press the OFF button and the UP arrow simultaneously
The pilot and main burner ignite and the remote is now in Manual Mode. In 'MANUAL MODE' you can:
 - turn on the main burner

- regulate the flame from low to high and back
 - turn off the burner leaving just the pilot burning
- In 'TEMP MODE' you can:
- set the room temperature so the thermostat in the remote automatically maintains that temperature
- In 'TIMER MODE' the stove:
- turns on and off according to the set time periods
 - automatically regulates the room temperature during the set periods

NOTE: WHEN OPERATING THE FIRE IN TEMP OR TIMER MODE, THE PILOT REMAINS LIT AND THE FIRE THEN AUTOMATICALLY SWITCHES ON AT PROGRAMMED TIMES TO BRING THE ROOM TO THE SET TEMPERATURE WHETHER OR NOT YOU ARE IN THE ROOM. NEVER LEAVE ANY COMBUSTIBLE MATERIALS WITHIN 1 METRE OF THE FRONT OF THE APPLIANCE.

2.1 SWITCHING BETWEEN MODES

- Press the SET button to change to Manual Operation
- Press again to change to Temperature Mode
- Keep pressing to run through all operating modes. These are:
 - MAN
 - DAY TEMP
 - NIGHT TEMP
 - TIMERand back to MAN

NOTE: MAN mode can also be reached by pressing either the UP or DOWN arrow

2.2 MAN MODE

- Press both the UP arrow and immediately press the OFF button to light the appliance. You hear a click as the fire begins the ignition process, (up to 30 seconds)
- Press the OFF button to turn the appliance off

INCREASING TEMPERATURE

- Press the UP arrow once to increase flame height one stage
- Press and hold the UP arrow to increase to maximum

DECREASING TEMPERATURE

- Press the DOWN arrow once to decrease flame height one stage
- Press and hold the DOWN arrow to decrease to minimum

At the lowest point the fire goes to 'standby mode' (only pilot lit)

NOTE: While pressing a button a symbol indicating transmission appears on the display. The receiver confirms transmission with an acoustic signal.

USER INSTRUCTIONS

Turning the Studio Off

- Press the Off button to extinguish the pilot

2.3 TEMP MODE

The display shows the current **room** temperature.

To increase or decrease the fire's output:

- Press the SET button to select either the DAY TEMP or the NIGHT TEMP mode by briefly pressing the SET button
- Hold the SET button until the TEMP display flashes and then let go
- Set the desired temperature with the UP and DOWN arrows. (Minimum temperature 5C, maximum 30C or fahrenheit)
- Press the OFF button to stop the display flashing or wait to return to TEMP mode.

NOTE: If you set a temperature that is beneath the current room temperature, the fire automatically switches to OFF.

NOTE: If you would like the Night temperature control to turn off then decrease the temperature until [---] is displayed.

2.4 TIMER MODE

There are two programmable settings you can make over a 24 hour period, P1 and P2

- P1 + ● = Start Timed Setting 1
- P1 + ☾ = End of Timed Setting 1
- P2 + ● = Start Timed Setting 2
- P2 + ☾ = End of Timed Setting 2

2.4.1 P1 - Program 1 for a Timed Setting

- Press the SET button until the TIMER mode is displayed
- Hold the SET button. The display flashes the current time for P1. **While the time displayed is flashing you can alter the hours and minutes set.**

To set the time your fire first lights, change the Start Timed Setting for P1 ● .

- Press the UP arrow to alter the hour
- Press the DOWN arrow to alter the minutes in 10 minute increments
- Press SET again to move to the End of Timed Setting, P1. The display shows the current setting for P1 ☾
This is the time your Studio first shuts down:
 - Press the UP arrow to alter the hour
 - Press the DOWN arrow to alter the minutes

2.4.2 P2 - Program 2 for a Timed Setting

Use the same steps outlined in 2.4.1 to change the setting for P2.

If you have already set P1 and want to alter the setting for

P2 only:

- Press the SET button until TIMER mode is displayed
- Hold the SET button **until the display flashes the current time** for P1 ●
- Press the SET button again to scroll past the settings for P1 ● and P1 ☾

With the time still flashing:

- Press the UP arrow to alter the hour
- Press the DOWN arrow to alter the minutes

Once all four times are set press the OFF button or simply wait to complete programming.

2.5 LOW BATTERY

"BATT" is displayed on the remote when its batteries need replacement.

2.6 SETTING THE TIME

- Simultaneously press the up and down arrow buttons
- Press the up arrow to set the hour and the down arrow to set the minutes
- Press OFF to return to the manual mode or simply wait

2.7 SETTING THE °C/24 HOUR OR °F/12 HOUR CLOCK

- Press OFF and the down arrow until the display changes from °C/24 hour clock to °F/12 hour clock and vice versa.

If the remote is removed, lost or damaged, signals transmitted to the receiver cease. Your fire will go to standby (pilot) mode after 6 hours.

2B TOUCH PAD CONTROL

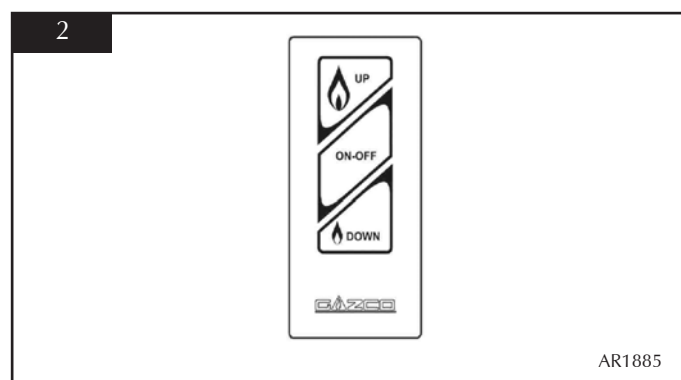

- Press the ON-OFF button to light the appliance, (up to 30 seconds)
- Press the UP button to increase the flame height
- Press the DOWN button to decrease the flame height. At the lowest point it goes to 'standby mode', (only pilot lit)
- Press the ON-OFF button to turn the appliance off

USER INSTRUCTIONS

EMERGENCY SHUT OFF

If the batteries fail during use of the fire, move the switch to the OFF (O) position, Diagram 3

(This switch is set to be ON during normal operation and must remain ON)

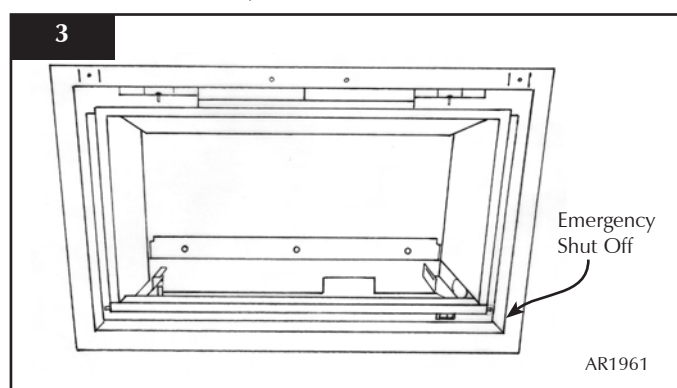

3. CLEANING THE STUDIO

3.1 Make sure the fire and surrounds are cool before cleaning.

Use:

- A dry cloth or stainless steel product to clean the polished plate
- A damp cloth for the painted firebox
- A damp cloth to clean the enamelled inner panels
- Use soap and water to clean the glass

3.2 **Opening the Glass Window**

3.2.1 Steel Frame

[If fitted with a Steel Frame, this needs to be removed first:

- Lift the frame upwards off its four support brackets, Diagram 4

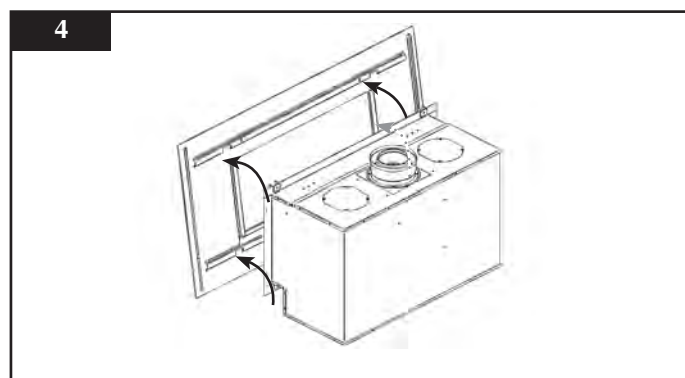

3.3 **All models**

Using the allen key provided:

- Release the two window locks at the top of the glass door, Diagram 5. The locks to move from shut to open towards the outer edges of the glass door, Diagram 5

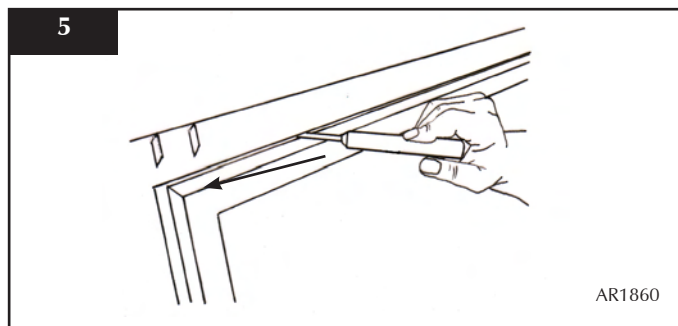

- Support the frame and let it fall gently forward
- Open it down to its stop position

When closing the window ensure the window catches are fully engaged.

4. CHANGING THE STUDIO BATTERIES

The appliance batteries are located under the polished plate mounting the wall switch.

- Undo the two screws securing the wall switch and plate and remove, Diagram 6

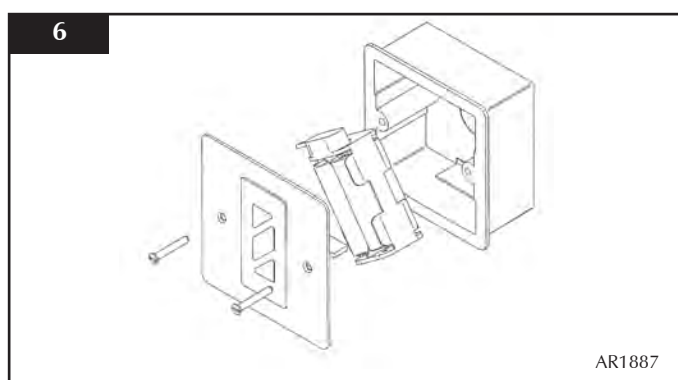

- Correctly position the four new AA size batteries
- Re-assemble the battery holder as shown in Diagram 7
- Ensure the touch pad cable is tucked to the left on fitting the wall plate back onto the wall

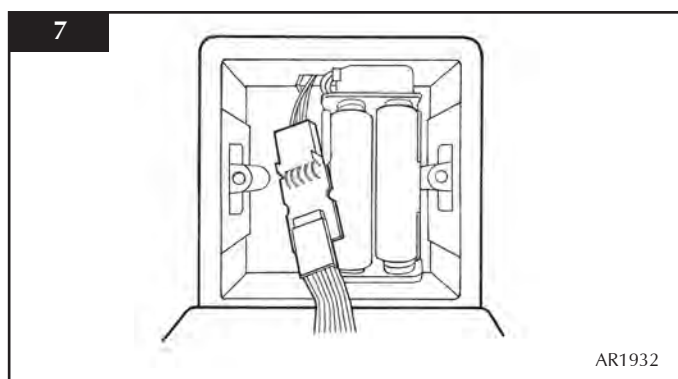

USER INSTRUCTIONS

5. ARRANGEMENT OF FUEL BED

- 5.1 If you need to replace pebbles or refill the tray, make sure the pebbles are flattened so they are level with the rim of the tray.

TAKE CARE NOT TO SPILL PEBBLES INTO THE PILOT AREA

ONLY PEBBLES SUPPLIED BY GAZCO CAN BE USED IN THIS FIRE.

6. FLAME FAILURE DEVICE

- 6.1 This is a safety feature incorporated on this appliance which automatically switches off the gas supply if the pilot goes out and fails to heat the thermocouple.

7. RUNNING IN

- 7.1 The surface coating on the metal used in your GAZCO fire will "burn off" during the first few hours of use producing a harmless and temporary odour. This will disappear after a short period of use. If the odour persists, ask your installer for advice.

8. SERVICING

- 8.1 The fire must be serviced every 12 months by a qualified Gas Engineer. In all correspondence always quote the Model number and the Serial number which may be found on the data badge.

9. VENTILATION

- 9.1 Any purpose provided ventilation should be checked periodically to ensure that it is free from obstruction.

10. INSTALLATION DETAILS

- 10.1 Your installer should have completed the commissioning sheet at the front of this book. This records the essential installation details of the appliance. In all correspondence always quote the Model number and Serial number.

11. HOT SURFACES

- 11.1 Parts of this appliance become hot during normal use.
- Regard all parts of the appliance as a 'working surface'
 - Provide a suitable fire guard to protect young children and the infirm

12. FIRE WILL NOT LIGHT

- 12.1 If you cannot light the Studio:
- Check that the emergency shut off switch is in the ON (1) position, see *Section 2, Emergency Shut Off*
 - Check and change the batteries in the remote handset
 - Check and change the appliance batteries, Section 4.
- Consult your Gazco dealer if the Studio still does not light.

INSTALLATION INSTRUCTIONS

TECHNICAL SPECIFICATION

COVERING THE FOLLOWING MODELS:

STUDIO 1 CF:	STUDIO 2 CF:
8700CFCHEC	8701CFCHEC
P8700CFCHEC	P8701CFCHEC

Model	Gas CAT.	Gas Type	Working Pressure	Aeration	Injector	Gas Rate m ³ /h	Input kW (Gross)		Country
							High	Low	
Studio 1 CF	12H	Natural G20	20mbar	6 x 10	390	0.657	6.9	4.0	GB, IE
Studio 1 CF	13+	Propane G31	37mbar	Open both sides	185	0.257	6.9	4.0	GB, IE
		Butane G30	29mbar			0.197			

Model	Gas CAT.	Gas Type	Working Pressure	Aeration	Injector	Gas Rate m ³ /h	Input kW (Gross)		Country
							High	Low	
Studio 2 CF	12H	Natural G20	20mbar	9 x 15 offset	530	0.791	8.3	4.2	GB, IE
Studio 2 CF	13+	Propane G31	37mbar	One side open + 10 x 16	225	0.312	8.3	4.2	GB, IE
		Butane G30	29mbar	Open both sides		0.238			

Studio 1					Efficiency Class 2 - 70%	NO _x Class 4
Studio 2					Efficiency Class 2 - 78%	NO _x Class 4
Weight	Fire Only	Profil	Bauhaus	Steel	Flue Size	
					TOP EXIT	REAR EXIT
Studio 1	52 Kg	3.6 Kg	3.6Kg	18.5Kg	127mm ø	178mm ø minimum
Studio 2	60Kg	4.6Kg	4.6Kg	21.8Kg	Gas Inlet Connection Size = 8mm ø	
					Minimum Flue Specification = T260/N2/0/D/1	
					Minimum Flue Temp = 220°C	

INSTALLATION INSTRUCTIONS

TECHNICAL SPECIFICATION

This appliance has been certified for use in countries other than those stated. To install this appliance in these countries, it is essential to obtain the translated instructions and in some cases the appliance will require modification. Contact Gazco for further information.

PACKING CHECKLIST

Qty Description	Fixing Kit containing:-
1 White Stone Chippings	1 x Instruction Manual 4 x Wood Screws 4 x Rawl Plugs 1 x Handset 4 x AA cell batteries 1 x 9V cell batteries 1 x wall box 1 x touch pad/wall plate 1 x battery holder

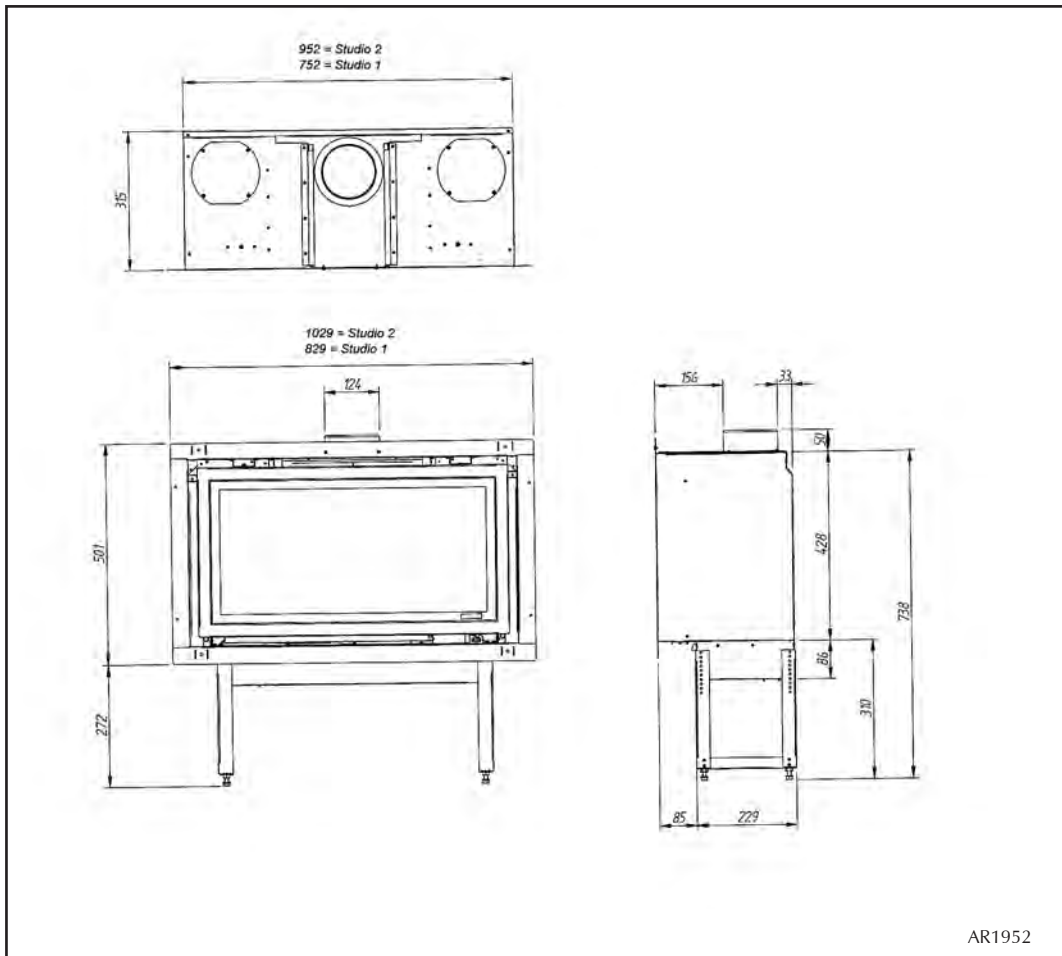

INSTALLATION INSTRUCTIONS

TECHNICAL SPECIFICATION

STEEL FRAME DIMENSIONS		
Dimension	Studio 1	Studio 2
A	1120	1350
B	675	675
C	646	846
D	320	320
E	177	177
F	237	237
G	25	25

PROFIL FRAME DIMENSIONS		
Dimension	Studio 1	Studio 2
A	846	1046
B	520	520
C	750	950
D	424	424
E	48	48
F	48	48
G	12.5	12.5

BAUHAUS FRAME DIMENSIONS		
Dimension	Studio 1	Studio 2
A	860	1060
B	534	534
C	750	950
D	424	424
E	55	55
F	55	55
G	28	28

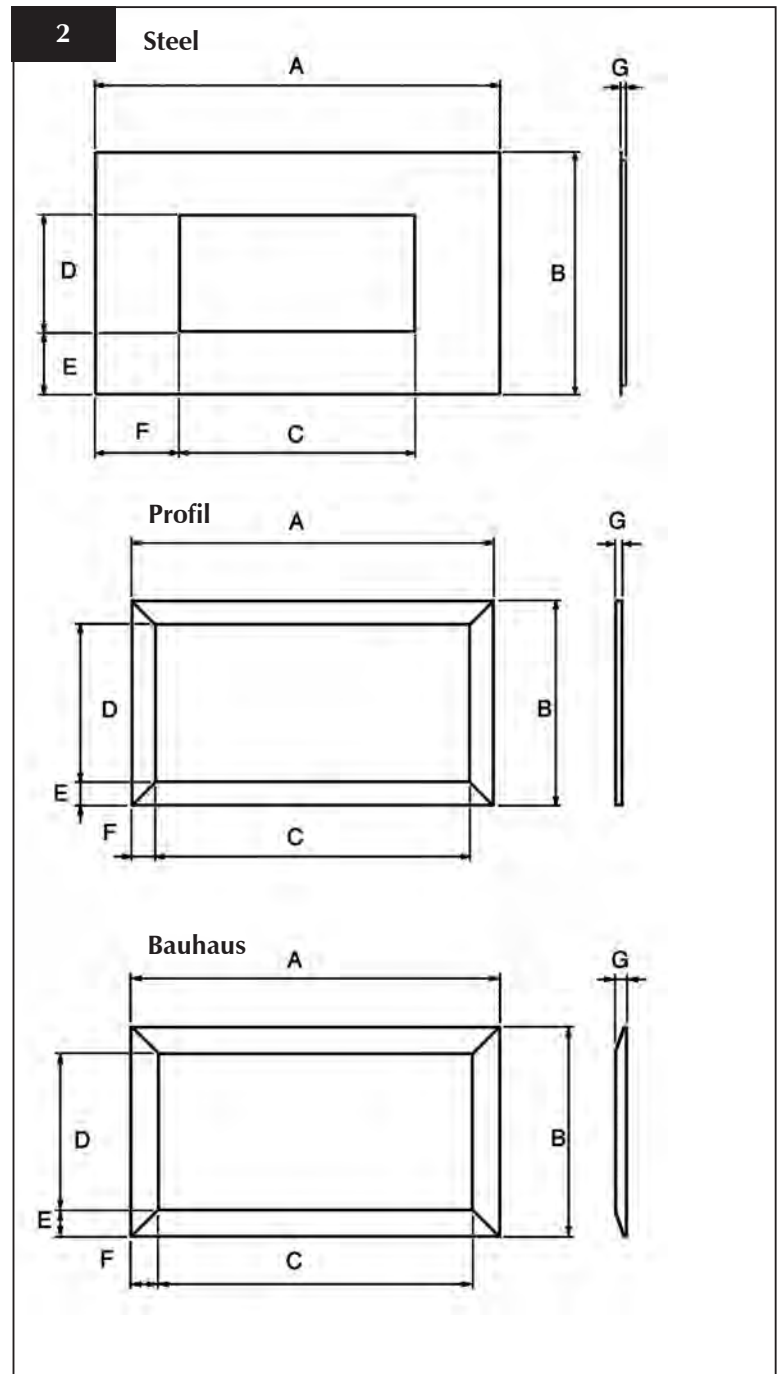

INSTALLATION INSTRUCTIONS

SITE REQUIREMENTS

1. FLUE AND CHIMNEY REQUIREMENTS

WHEN INSTALLING A FLUE SYSTEM PLEASE REFER TO THE MANUFACTURER'S INSTRUCTIONS.

The European chimney standards now describe chimneys and flues by their temperature, pressure and resistance to corrosion, condensation and fire. To identify the correct flue system, the minimum flue specification is shown in the *Technical Specification*. Existing chimneys are not covered by this system.

The flue must be installed in accordance with all local and national regulations and the current rules in force:

- A flexible liner must be continuous from the appliance spigot to the roof terminal
- The minimum effective height of the flue must be 3 metres (10ft)
- The flue must be free from any obstruction
- Any damper plates must be removed or secured in the fully open position and no restrictor plates fitted
- The chimney should be swept immediately before installing the appliance, but it need not be swept if you can see the chimney is clean and free from obstruction throughout

2. FLUE OPTIONS

There are three suitable Conventional Flues:

- **Stud work is Top Exit only - Twin Wall Rigid**
127mm (5")
- **Top Exit - Builder's Opening Lined**
127mm (5")
- **Rear Exit - Builder's Opening Unlined**
178mm (7") minimum

3. GAS SUPPLY

THIS APPLIANCE IS INTENDED FOR USE ON A GAS INSTALLATION WITH A GOVERNED METER.

- 3.1 Make sure local distribution conditions (identification of the type of gas and pressure) and the adjustment of the appliance are compatible before installation.
- 3.2 Ensure the gas supply delivers the required amount of gas and is in accordance with the rules in force.
- 3.3 You can use soft copper tubing on the installation and soft soldered joints outside the appliance and below the fire.
- 3.4 A factory fitted isolation device is part of the inlet connection; no further isolation device is required.
- 3.5 All supply gas pipes must be purged of any debris that may have entered prior to connection to the appliance.
- 3.6 The gas supply enters through the silicone panel located on the LEFT-HAND side of the outer box:

- Slit with a sharp knife prior to passing the supply pipe through

- 3.7 The gas supply must be installed in a way that does not restrict the removal of the appliance for servicing and inspection.

4. VENTILATION

IMPORTANT: Ensure any national ventilation requirements are taken into account during installation of the fire.

UK ONLY:

The Studio 1 has a nominal input not exceeding 7.0kW and does not normally require any additional permanent ventilation.

The Studio 2 must have permanent ventilation with a minimum open area of 5.85cm².

FOR THE REPUBLIC OF IRELAND REFER TO THE RULES IN FORCE FOR VENTILATION REQUIREMENTS

5. APPLIANCE LOCATION

NOTE: It is recommended you construct the back panel of the fireplace from natural materials cut into three or more sections to prevent cracking. Resin-based materials may not be suitable. This appliance is an effective heat producer and attention must be paid to the construction and finish of the fireplace.

When preparing the aperture for installation into a builder's opening, the front of the wall must be cut out down to the level on which the appliance is to stand. Then, to obtain the correct dimensions shown in Diagram 1a, the lower section of wall must be reconstructed as shown in Diagram 1a

- 5.1 This appliance must stand on a non-combustible base that is at least 12mm thick; the minimum opening dimensions are shown in Diagram 1a.

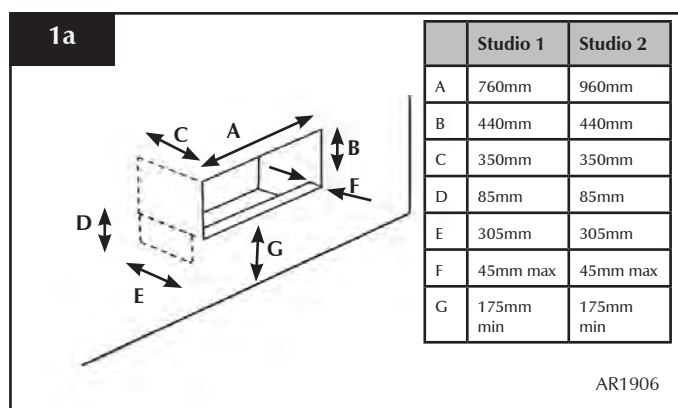

INSTALLATION INSTRUCTIONS

SITE REQUIREMENTS

- 5.2 When the appliance is installed in a masonry chimney without a liner, there must be a minimum debris collection area, Diagram 1b

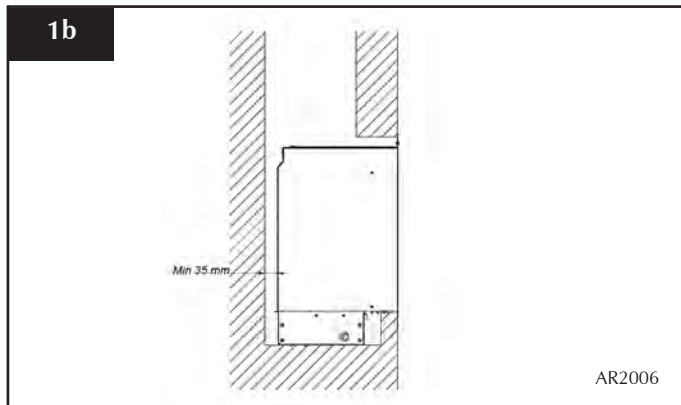

- 5.3 **DO NOT** install onto a combustible wall; all combustible materials must be removed from the area shown in Diagram 1c.

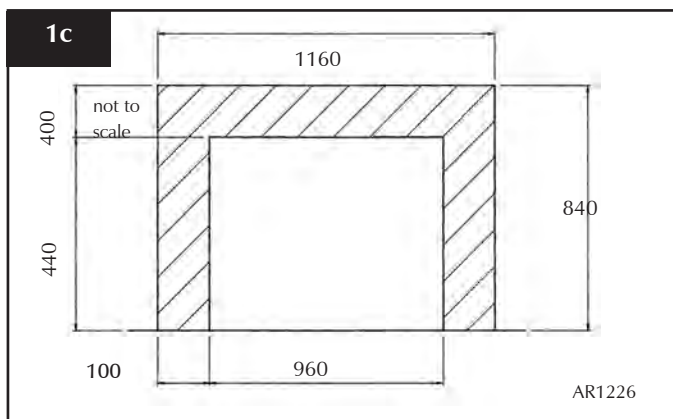

- 5.4 A combustible shelf must be a minimum of 400mm above the top of the appliance. This is based on a 150mm deep shelf. For every extra 13mm of depth add 25mm above the 400mm from the top of the appliance, not the frame.
- 5.5 A side wall must be a minimum of 300mm from the side of the appliance, not the frame.

INSTALLATION INSTRUCTIONS

INSTALLATION

IMPORTANT: REFER TO DATA BADGE AND TECHNICAL SPECIFICATION AT THE FRONT OF THE MANUAL TO ENSURE THE APPLIANCE IS CORRECTLY ADJUSTED FOR THE GAS TYPE AND CATEGORY APPLIED IN THE COUNTRY OF USE.

FOR DETAILS OF CHANGING BETWEEN GAS TYPES REFER TO SECTION 10, **SERVICING**, 'REPLACING PARTS'.

1. SAFETY PRECAUTIONS

- 1.1 For your own and other's safety, you must install this appliance according to local and national codes of practice. Failure to install the stove correctly could lead to prosecution:
 - Read these instructions before installing and using this stove.
- 1.2 These instructions must be left intact with the user.
- 1.3 Do not attempt to burn rubbish on this appliance.
- 1.4 Keep all plastic bags away from young children.
- 1.5 Do not place any object on or near to the appliance and allow adequate clearance above the appliance.

IF THE APPLIANCE IS EXTINGUISHED OR GOES OUT IN USE, WAIT 3 MINUTES BEFORE ATTEMPTING TO RELIGHT THE APPLIANCE.

2. INSTALLATION OF THE APPLIANCE

- 1.1 This appliance can be installed in four different ways:
 - 1) Builder's opening with a frame
 - 2) Builder's opening without a frame
 - 3) Stud work with a frame
 - 4) Stud work without a frame

Where no frame is used an edge kit is available to enable the installer to plaster to a finished edge: Kit No. 8727 CFFK01 for Studio 1 and 8727 CFFK02 for Studio 2

Options 1) and 2) above can be:

- top exit with a liner
 - rear exit without a liner
- 1.2 The Studio is supplied with a flue fixing plate to attach the flue to the appliance within the aperture, Diagram 1.

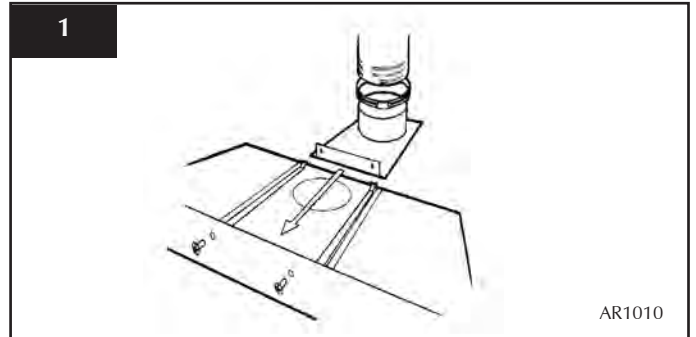

When installing the appliance into a masonry chimney without a liner, it must be converted to a rear exit:

- Remove the two fixing screws securing the spigot assembly
- Slide the blanking plate into the guides
- Replace the two fixing screws, Diagram 2

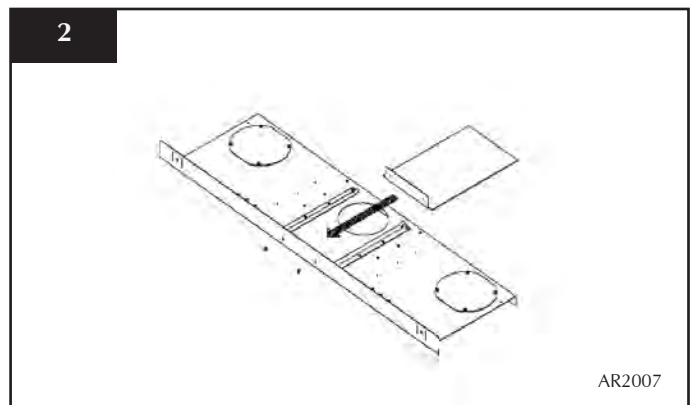

The flue must be in good condition and clear products of combustion, see *Commissioning*)

Option 3) and 4) must be fitted using the top exit only with rigid twin wall flue pipe.

THE APPLIANCE IS SUPPLIED WITH A WALL BOX CONTAINING THE BATTERIES AND TOUCH PAD. THIS MUST BE RECESSED INTO THE WALL WITH ACCESS FOR THE CABLES PRIOR TO FITTING THE APPLIANCE.

- 2.1 Remove the appliance from the carton and discard all unnecessary packaging. Ensure no components are thrown away when unpacking.
- 2.2 To access the controls and gas inlet:
 - Remove the glass door, enamelled liners, burner and splitter plate. See Section 4
- 2.3 The gas supply enters the fire through a silicon panel on the floor under the access panel, Diagram 3:
 - Slit with a sharp knife before bringing through the supply pipe, Diagram 1

INSTALLATION INSTRUCTIONS

INSTALLATION

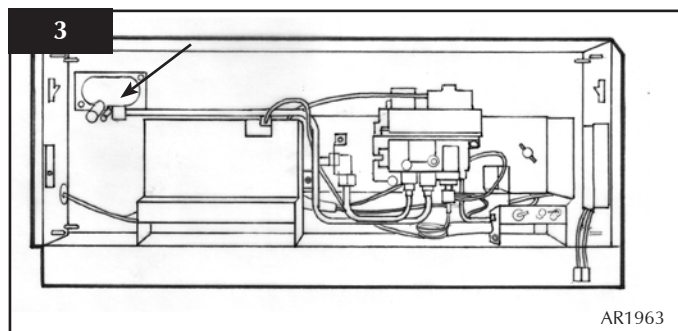

3. STUD WORK INSTALLATION

THERE IS AN OPTIONAL DUCT KIT, CODE No. 8572 WHICH CAN BE FITTED AT THE SAME TIME AS THE APPLIANCE INSTALLATION.

- 3.1 Combustible parts of the stud work must be kept beyond the minimum dimensions shown in Diagram 4. Even if the framework is protected by non-combustible material, you must maintain these dimensions, Diagram 4.

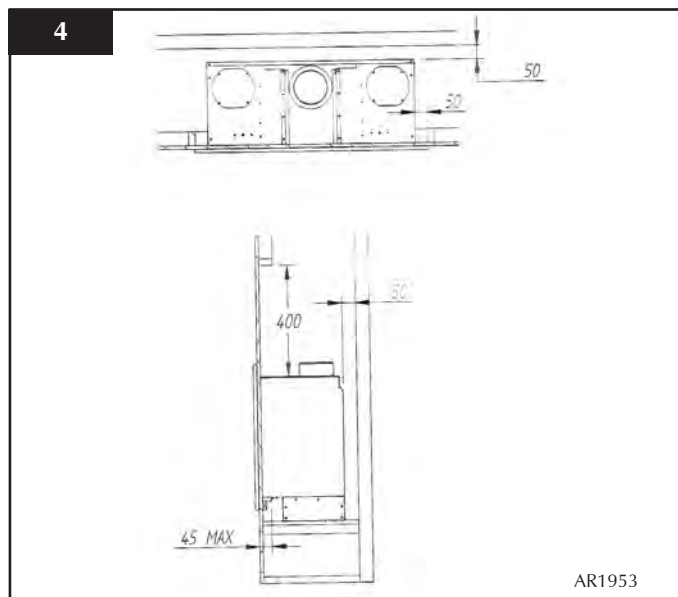

- 3.1.1 **Do not** pack the void around or above the appliance with insulation materials such as mineral wool.
- 3.1.2 **THE VOID BUILT FOR THE CASSETTE MUST BE VENTILATED TO PREVENT A BUILD-UP OF HEAT. IF THE VOID IS SEALED, THEN YOU MUST FIT VENTS AT BOTH LOW AND HIGH LEVELS OF APPROXIMATELY 50CM² EACH. THESE VENTS MUST TAKE COLD AIR FROM THE ROOM AND RETURN WARM AIR BACK INTO THE ROOM.**
- 3.1.3 **AN ACCESS HATCH MUST BE LEFT IN THE SIDE OF THE CHIMNEY BREAST FOR FUTURE SERVICING AND INSPECTION OF THE FLUE AND APPLIANCE.**

3.2 STUD WORK INSTALLATION METHOD 1 (FRAME)

NOTE: With the legs fitted, this appliance can stand directly on the floor (normally in a false chimney breast), or without the legs on a protected platform at the required height, Diagram 5

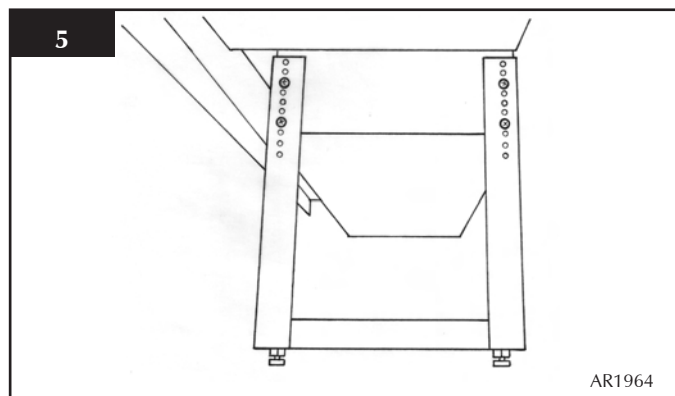

Build the stud work chimney breast and enclosures to the desired size to include the protected platform at the required height.

- Line the aperture for the appliance with 12mm thick non-combustible material as shown, Diagram 6

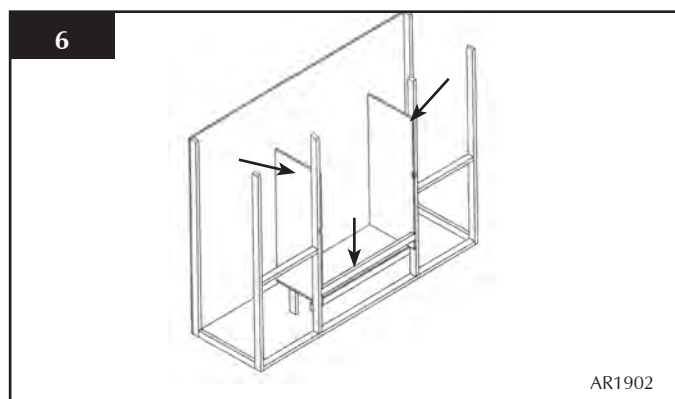

- Ensure the clearances are maintained, see Diagram 7
 - Site the appliance within the aperture
 - Provide gas and battery power services into the cassette void on the left-hand side
 - Mark out the position to fit the supplied top support bar into the stud work at the correct height. This bar needs to be recessed into the stud work, Diagram 5
- It may be advisable at this stage to remove the fire before plastering the enclosure.

INSTALLATION INSTRUCTIONS

INSTALLATION

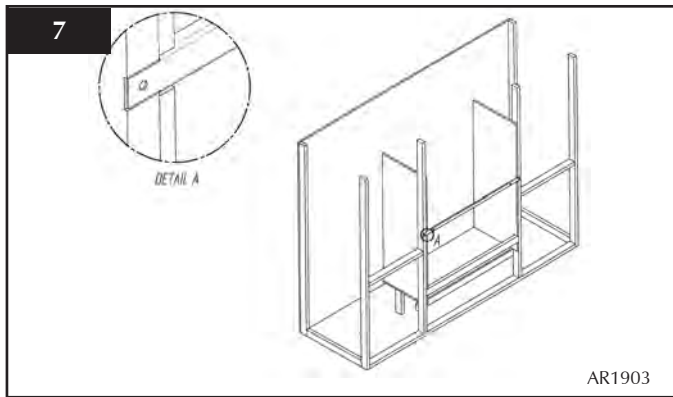

- Fit the supplied top support bar into the stud work at the correct height, Diagram 8, because no combustible material can be used above the fire

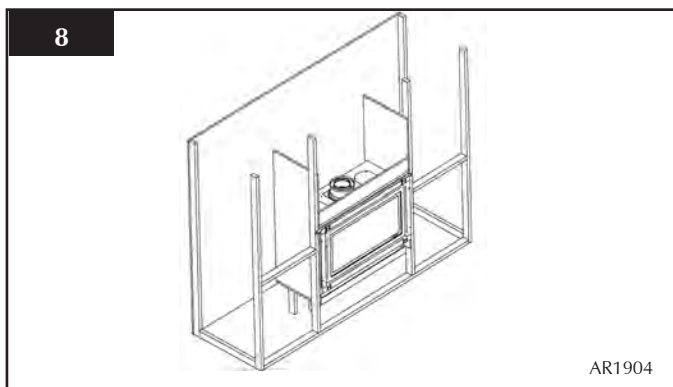

NOTE: If a frame is to be fitted, attach the brackets before installing the appliance.

- Attach the 4 frame fixing brackets to the fire, Diagram 9
- Fix foam seal to the outer flange of the fire

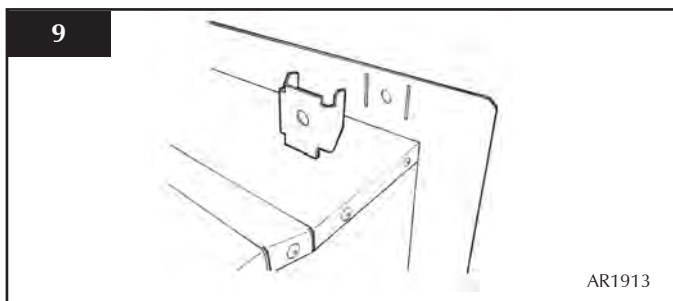

- Position the fire
- Fit non-combustible board to the stud work around the fire. This should extend a minimum of 400mm above the appliance and at least 50mm to the sides of the appliance (from the outer box, not the flanges).

For non-combustible area see Diagram 2b.

The remaining area can be finished using plasterboard:

- Apply a plaster finish to the front of the chimney breast
- Secure the fire back to the stud work using four screws through flange, bracket, support bar
- Decide on the position for the wall box containing the batteries and wall switch
- Connect the wire from the fire to the battery pack, Diagram 10

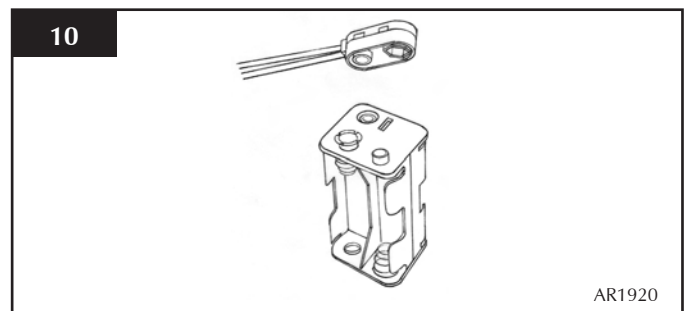

- Connect the wire from the fire to the touch pad/connector, Diagram 11

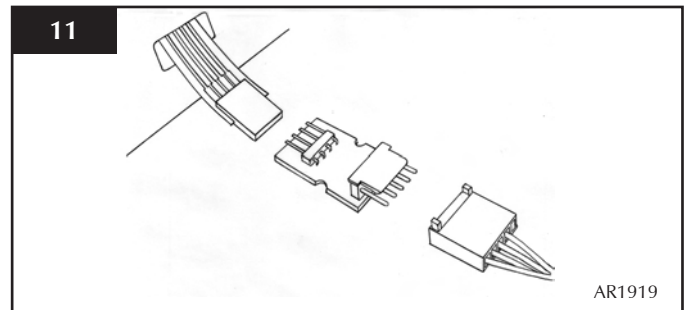

- Correctly position the four new AA size batteries
- Re-assemble the battery holder as shown in Diagram 12
- Ensure the touch pad cable is tucked to the left on fitting the wall plate back onto the wall

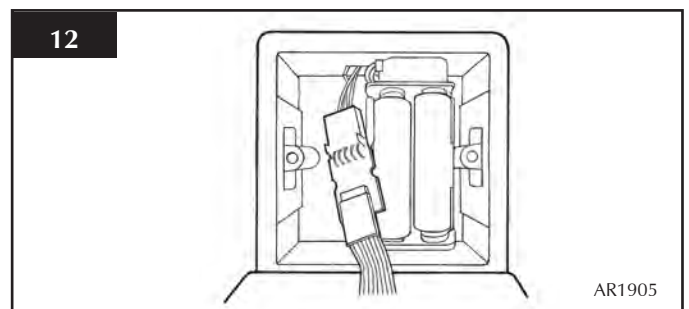

- Secure the wall plate with the touch pad attached to the wall box, Diagram 13

INSTALLATION INSTRUCTIONS

INSTALLATION

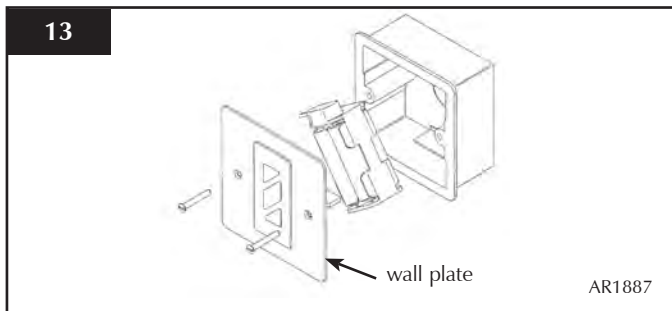

Because of the high temperatures this fire achieves, it is advisable to use marble slips or similar material between the appliance and the plasterboard

Never use a one-piece slip as expansion (even cracking) can occur. If a slip is used, longer screws are needed to secure the appliance.

- Connect the flue system and gas services using the opening in the side of the chimney breast for access. After commissioning, finish the sides of the chimney breast, Diagram 14

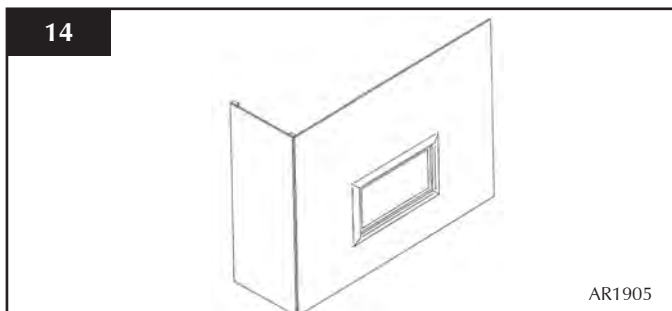

3.3 STUD WORK INSTALLATION METHOD 2 (EDGE)

For this cool-wall Edge installation, the convected heat of the fire is channelled into the chimney cavity and vented at the top.

There is an optional Studio 1 Edge Fixing Kit available for installing the fire without a frame. CODE No. 8727CFFK01 (STUDIO 1) 8727CFFK02 (STUDIO 2). Using the fixing kit:

- Fit the two side and bottom channels to the front flange of the fire, Diagram 15. There is a deliberate gap at the top for convected heat

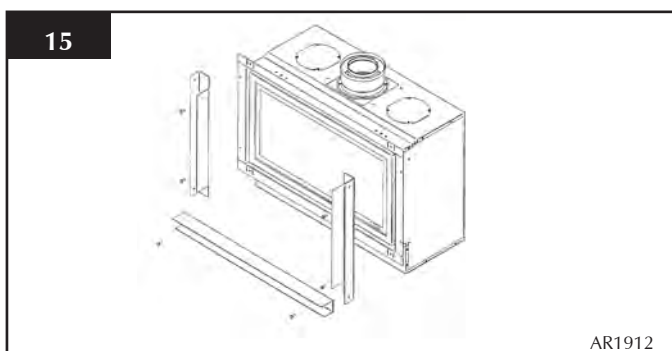

This now determines the width of your two vertical stud work supports. The kit has been designed so that 12mm thick plasterboard can be taken to the three channels, Diagram 16

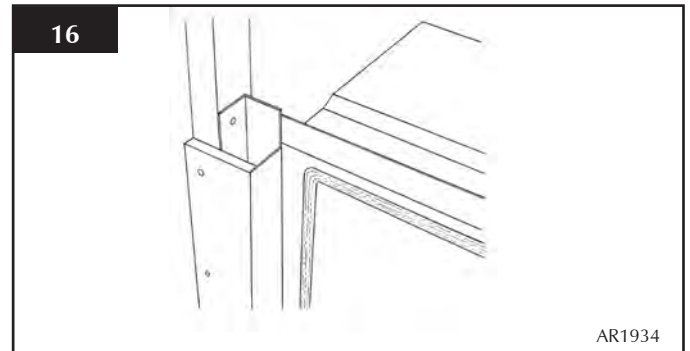

- Fix the edge of the vertical support flush to the edge of the channel

Build the stud work chimney breast to the desired size:

- Ensure all clearances to combustible material are maintained, 3.1 above

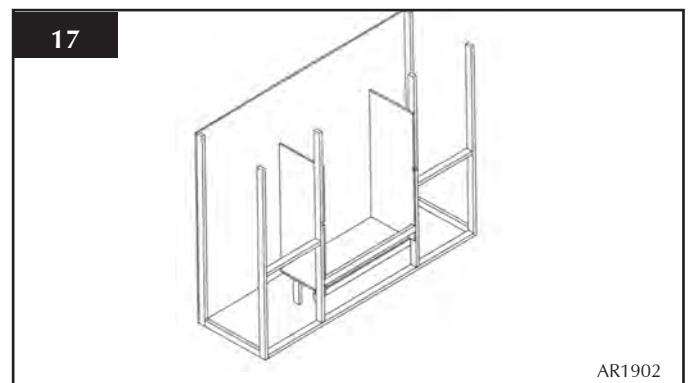

- Fit non-combustible board to the stud work above the fire. This should extend a minimum of 400mm above the appliance.
 - Fit plasterboard to the remaining chimney breast front
 - Decide on the position for the wall box containing the batteries and wall switch
 - Mount it into the stud work chimney breast connecting up the wires from the fire, see *Stud Work Installation with Frame* for wiring detail on previous page
 - Connect the flue system and gas services using the opening in the side of the chimney breast for access
- After commissioning, finish the sides of the chimney breast, Diagram 18

INSTALLATION INSTRUCTIONS

INSTALLATION

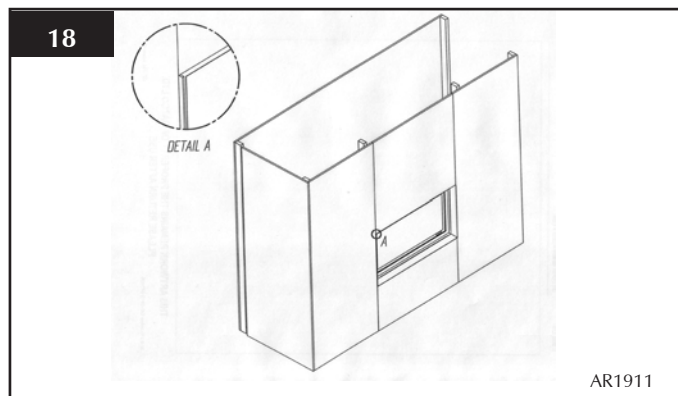

The top of the chimney breast must have a minimum 200mm² vent.

- Apply a plaster finish to the chimney breast

NOTE: Refer to paragraph 4.11 to check gas pressure

4. MASONRY CHIMNEY INSTALLATION

NOTE: Do not use the legs (of the appliance) in this installation

- 4.1
- Remove the glass door
- Using the allen key provided:
- Release the two window locks.

The locks need to be moved from shut to open towards the outer edge of the door, Diagram 19.

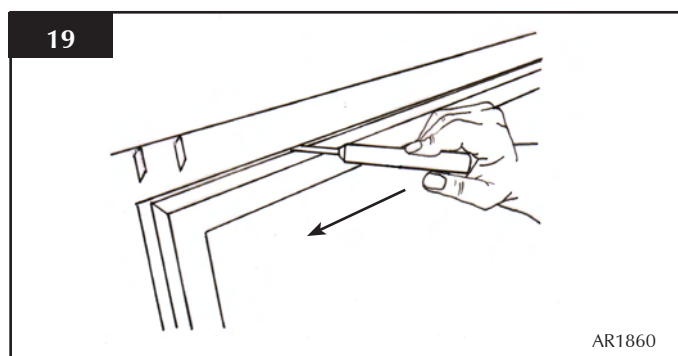

- 4.2 With the door lowered:
- Remove the spring clip from the right-hand hinge pin, Diagram 20

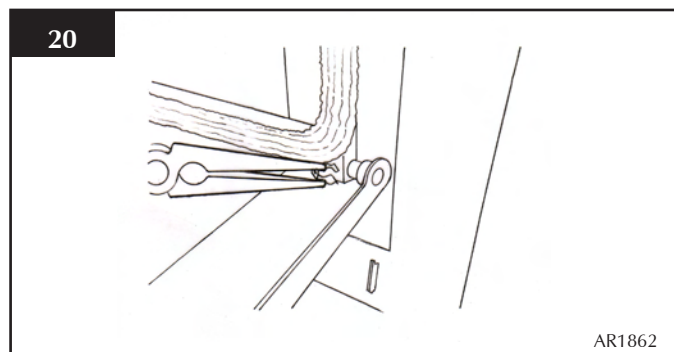

- Raise the door to almost upright and move the door left. This releases the left-hand side off its hinge pin
- Lower the left-hand side of the door to clear the pin and move the door to the right to release it from the right pin. The door is now free to remove, Diagram 21

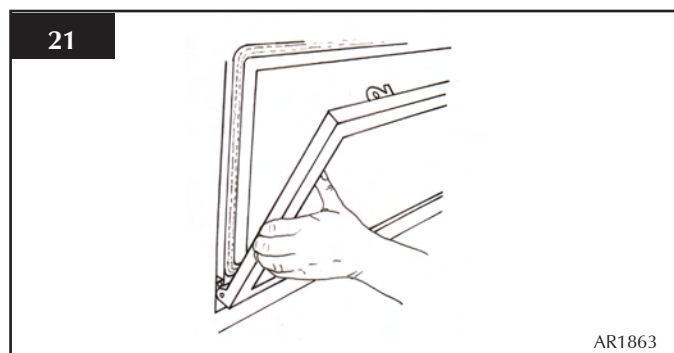

- 4.3
- Remove the two enamelled side panels. (Hold the rear panel whilst removing the second side to prevent it falling).
 - Remove the remaining rear and lower panel, Diagram 22

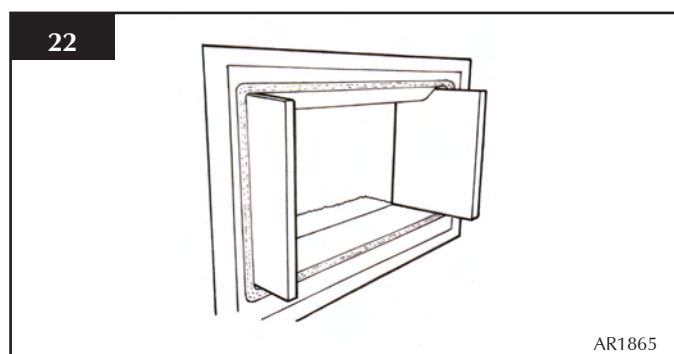

- 4.4
- Remove the screw retaining the burner
 - Move the burner to the left to disengage the burner flange from the slot and injector
 - Raise the right side and remove the burner, Diagram 23

INSTALLATION INSTRUCTIONS

INSTALLATION

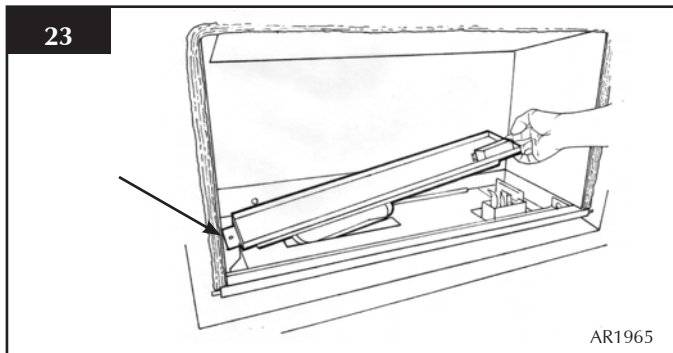

- 4.5
- Loosen the two screws retaining the plate beneath the burner
- The front of the plate can now be lifted off the screws:
- Pull it forward and remove, Diagram 24

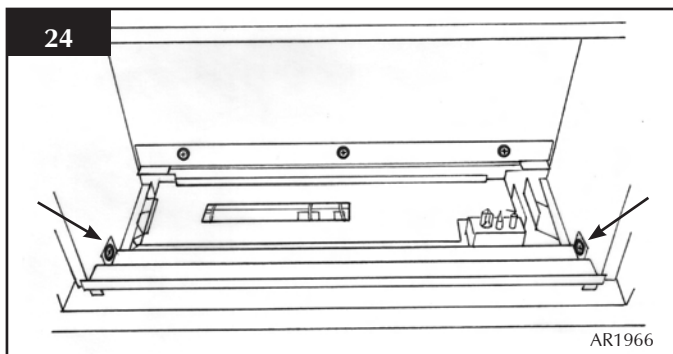

- 4.6
- Remove the three screws retaining the rear back panel
 - Lift and pull forward off the slotted brackets

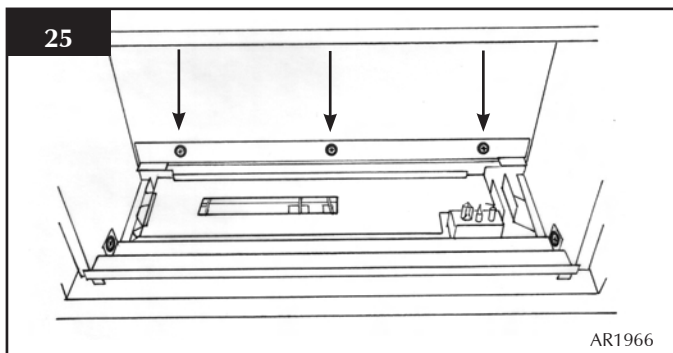

- 4.7 With the appliance on its back:
- Remove the three wing nuts and screws retaining the loose box, Diagram 26.

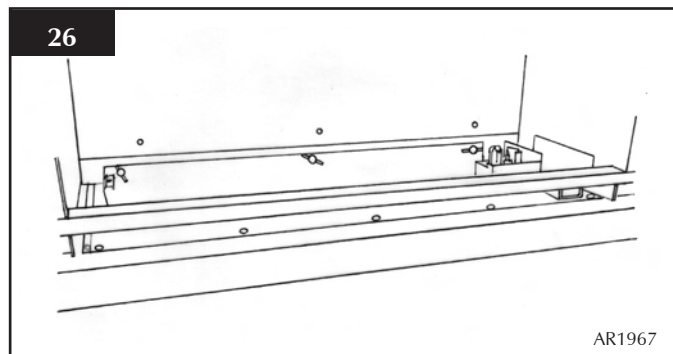

- Move the box forward to release the rear off the studs
- Tilt the front edge of the box upwards and remove from the appliance

4.8 METHOD 1 - FRAME

- Fit the four frame fixing brackets through the rear of the flanges.
- Attach the foam seal around the rear of the flange, Diagram 27

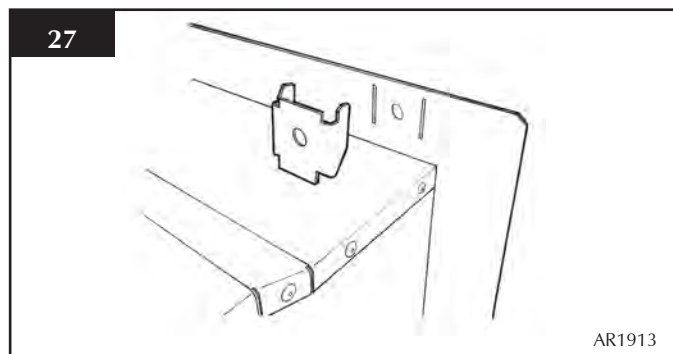

- Fit the main firebox into the aperture and secure with the screws and rawl plugs provided through the top and bottom flanges, Diagram 28

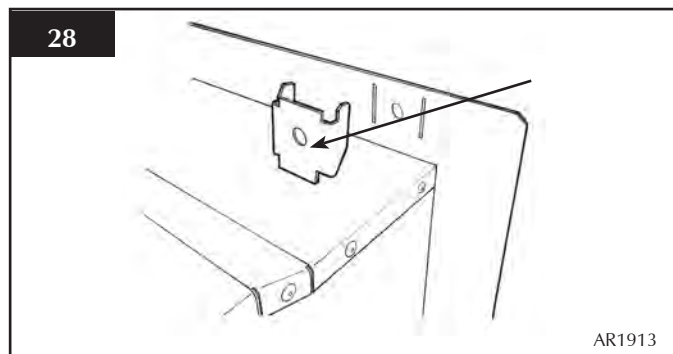

INSTALLATION INSTRUCTIONS

INSTALLATION

- Feed the wires for the remote touch pad through the grommet in the left side of the loose box
- The wires are then fed inside the firebox and routed through the available access
- Replace the loose box inside the main firebox ensuring the wires are not trapped
 - Replace the three wing nuts and seven screws
 - Connect the gas supply and check for leaks
 - Replace the rear panel ensuring the bottom edge locates in the tapered brackets, Diagram 29

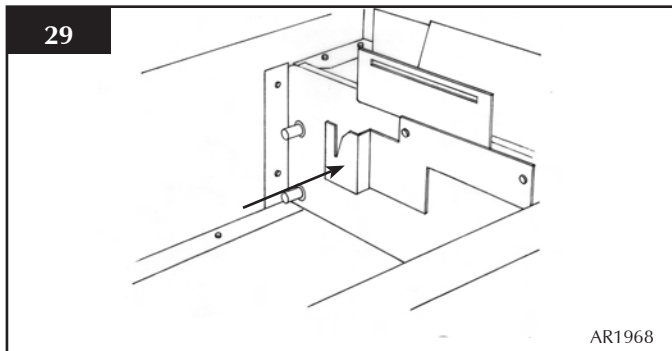

NOTE: To check gas pressure refer to paragraph 4.11

- Replace the splitter plate
- Locate the rear two tabs into the rear panel
- Engage the two side slots over the screws and secure, Diagram 30

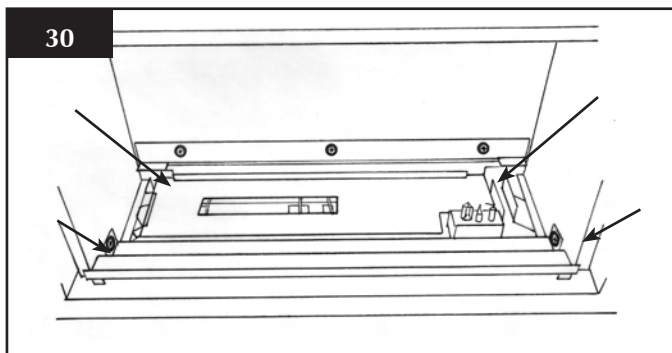

To replace the burner:

- Locate the left-hand side into the burner bracket
- Lower the right-hand side to engage the injector onto the venturi and also the pilot into the aperture in the burner skin
- Push the burner to the right and engage the burner into the slot in the bracket
- Replace the fixing screw, Diagram 31

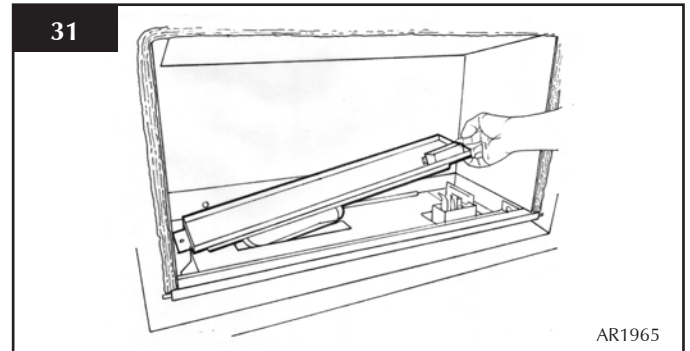

To replace the doors and panels, refer to *Replacing Parts, Section 3 and 5*

4.9 METHOD 2 - NO FRAME

The front of the chimney breast has to be studded and boarded to allow the edge kit to be fitted.

For this cool-wall Edge installation, the convected heat of the fire is channelled into the cavity between the existing chimney and the false wall, then vented at the top. The vent should have a minimum open area of 200mm.

- Proceed as described in *Section 4.1 to 4.8*, but do not fit the frame brackets

You have now removed the box from the appliance and should use the following:

- Fit the edge kit to the two sides and lower edge using the screws and rawl plugs provided, Diagram 32

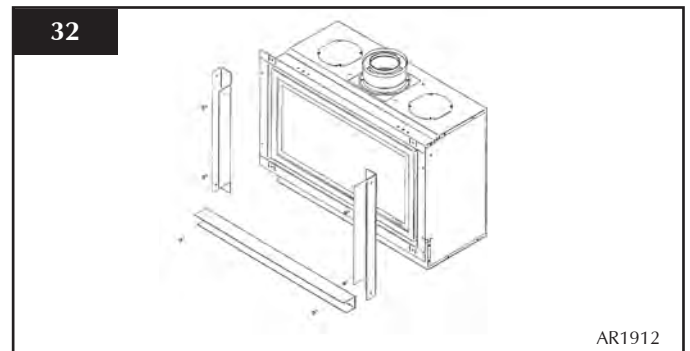

- Stud the face of the chimney breast using the method described in *Section 3.3, Diagrams 14, 15*.

DO NOT FIX ANY HORIZONTAL STUD WORK ABOVE THE APPLIANCE AS THIS WILL PREVENT THE CONVECTED AIR ESCAPING THROUGH THE VENTS

- Fit the non-combustible board and the plasterboard as described in *Section 3.3*
- Apply plaster skim to the front of the chimney breast

INSTALLATION INSTRUCTIONS

INSTALLATION

BOTH METHOD 1 OR 2 - MASONRY INSTALLATION

- 4.10 • Remove the compression elbow from the appliance and connect it to the gas supply pipe

As the loose box is fitted into the main appliance:

- Pass the elbow and supply pipe through the silicone panel on the left side
- Engage the rear of the box onto the three studs on the rear of the appliance and lower the front edge
- Replace the three wing nuts and seven screws
- Replace the rear loose panel
- Ensure the lower edge engages into the tapered brackets
- **PURGE THE SUPPLY PIPE.** This is essential to expel any debris that may block the gas controls
- Connect the elbow to the appliance inlet pipe, Diagram 33

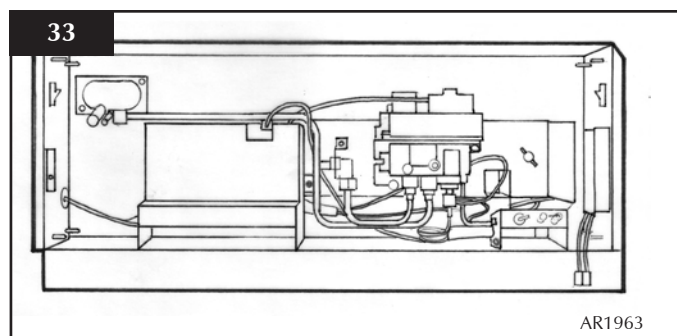

- 4.11 • Connect a suitable pressure gauge to the test point located on the inlet fitting
- Turn on the gas
- The burner must be temporarily fitted whilst completing this procedure
- Light the appliance and check for leaks
 - Turn the appliance to maximum and check that the supply pressure is as stated on the data badge
 - Turn off the gas and replace the test point screw
 - Turn the gas back on and check the test point for leaks
 - Replace the splitter plate and burner

5. ASSEMBLING THE APPLIANCE

- 5.1 • Add the pebbles making sure they are flattened so they are level with the rim of the tray
- TAKE CARE NOT TO SPILL PEBBLES INTO THE PILOT AREA
- ONLY PEBBLES SUPPLIED BY GAZCO CAN BE USED IN THIS FIRE

- 5.2 With the back panel held in place:
- Place the bottom panel at the base of the fire
 - Slide the side panels into position

- 5.2 With the back panel held in place:
- Place the bottom panel at the base of the fire
 - Slide the side panels into position

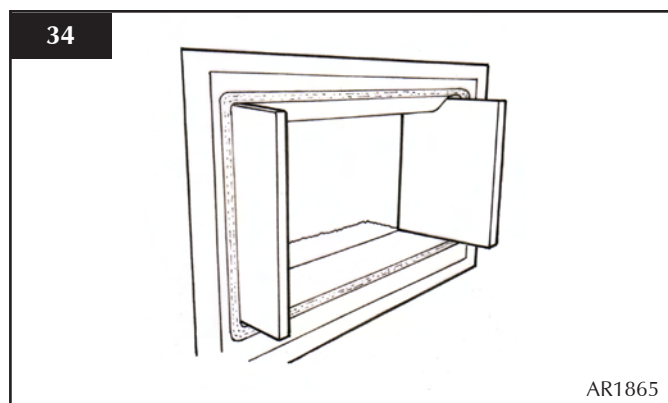

- 5.3 To fit the window frame:
- Keep the frame in the upright position with the locks uppermost
 - Offer the frame to the foot of the opening
 - Slide the frame to the right to locate the right hinge pin

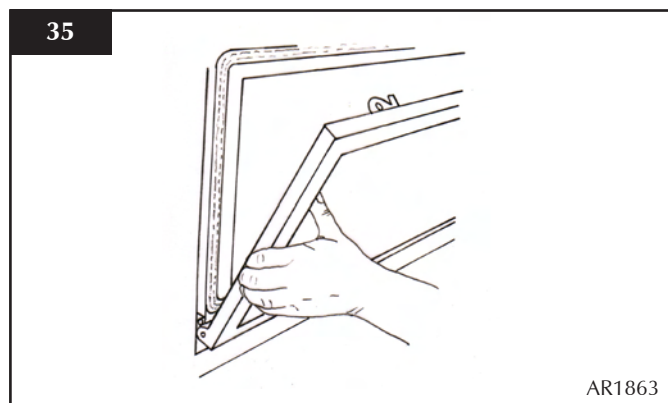

- 5.4 • Manoeuvre the frame up towards the left side to locate the left hinge pin
- Slide onto the hinge with a right movement
 - Secure in place with a spring clip at the right hinge pin, Diagram 36

INSTALLATION INSTRUCTIONS

INSTALLATION

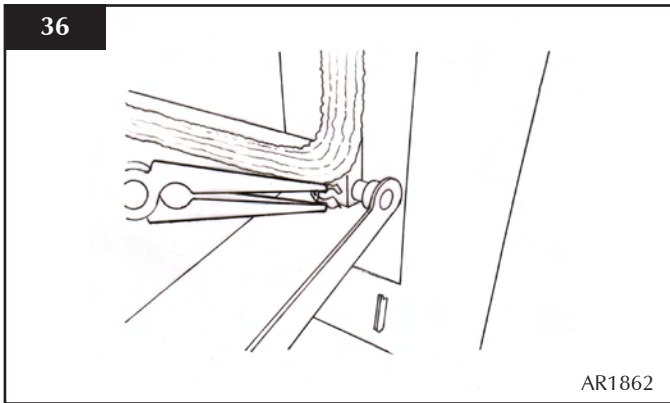

- Close the window
- 5.5 Using the allen key provided:
- Close the window locks by moving from open to shut towards the window centre

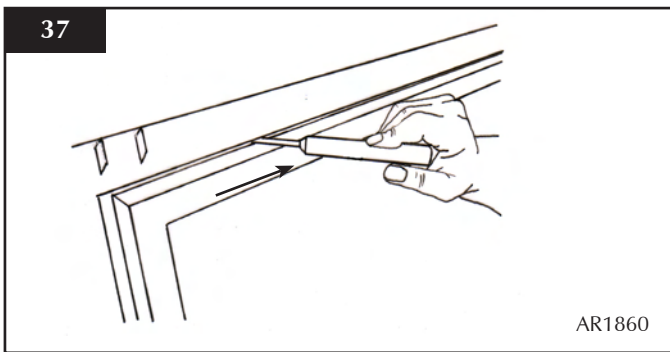

6. LIGHTING THE STUDIO

Note: The Emergency Shut Off switch must be in the ON position, refer to Section 2, User Instructions.

There are two ways of lighting the Studio:

- by thermostatic remote control
- using the fire's touch pad

THERMOSTATIC REMOTE CONTROL

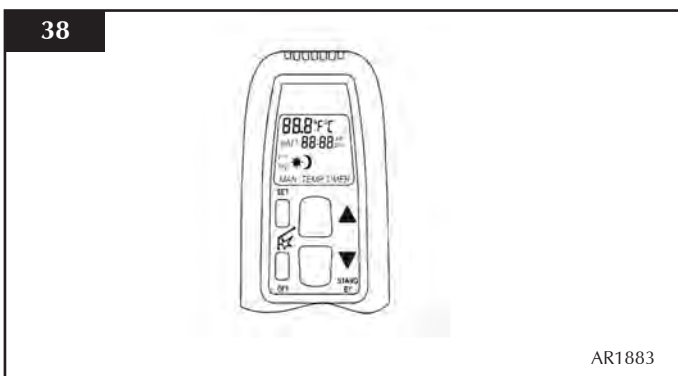

Turning the Studio On

Your remote can control the gas fire from pilot ignition through to shut down.

To turn the fire on:

- Press the OFF button and the UP arrow simultaneously
- The pilot and main burner ignite and the remote is now in Manual Mode. In 'MANUAL MODE' you can:
- turn on the main burner
 - regulate the flame from low to high and back

TOUCH PAD CONTROL



- Press the ON-OFF button to light the appliance, (up to 30 seconds)
- Press the UP button to increase the flame height
- Press the DOWN button to decrease the flame height. At the lowest point it goes to 'standby mode', (only pilot lit)
- Press the ON-OFF button to turn the appliance off

COMMISSIONING

7. COMMISSIONING

- 7.1 Check the flame picture
- 7.2 Check the gas pressure
- 7.3
- Close all door and windows in the room
 - Ignite the Studio and operate on maximum for 5 minutes
 - Position a lighted smoke match just inside the draught diverter opening and check all smoke is drawn in along the opening
- If there is any doubt:
- Run the appliance for a further 10 minutes and repeat the test, Diagram 40

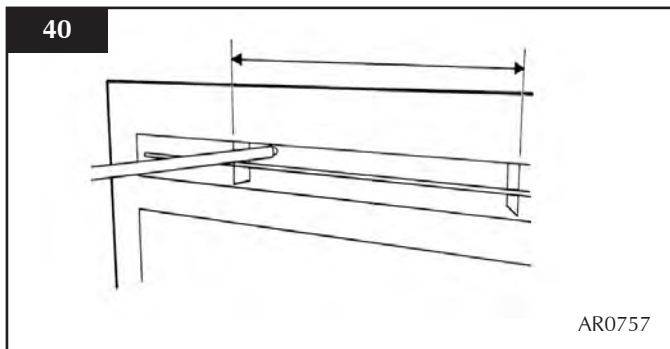

If there are any extractor fans in the room or adjacent rooms, the test must be repeated with the fans running on maximum.

IF SPILLAGE PERSISTS, DISCONNECT THE APPLIANCE AND SEEK EXPERT ADVICE.

For future reference, record the installation details on the *Commissioning Sheet* on page 3.

SERVICING INSTRUCTIONS

SERVICING / FAULT FINDING CHARTS

1. SERVICING REQUIREMENTS

This appliance must be serviced at least once a year by a competent person.

All tests must be serviced by best practice as described by the current CORGI recommendations.

- 1.1 Before any tests are undertaken on the stove:
- Conduct a gas soundness test for the property to ensure there are no gas leaks prior to starting work.

- 1.2 Fully check the operation of the stove

Special checks

1.2.1 Clean any lint or fluff from the pilot - pay particular attention to the aeration hole in the side of the pilot

1.2.2 Clean away any fluff or lint from under the burner

1.2.3 Check the spark gap on the pilot is correct

- Correct any faults found during the initial tests
- Re-commission the stove conducting the usual safety checks

- 1.3 Advise the customer of any remedial action taken.

REPLACE BATTERIES BEFORE ATTEMPTING TO RECTIFY ANY FAULTS

IF THE FIRE DOES NOT WORK, BUT HAS WORKED IN THE PAST:

- **CHECK THE EMERGENCY SHUT OFF SWITCH, (BOTTOM RIGHT CORNER BY THE DOOR), IS SWITCHED ON, SEE USER SECTION, PAGE 6**

ELECTRONIC CONTROL VALVE FAULT ANALYSIS		
Symptom	Cause	Remedy
3 short beeps from control	Batteries low in appliance	Replace appliance batteries
No ignition, 5 seconds continuous tone (there can be several short beeps before)	1. ON/OFF switch is in OFF position 2. Loose/damaged wire	1. Move switch to ON position 2. Check interrupter block and wires
No ignition, no tone, motor turned slightly when operated	Receiver board damaged	Replace receiver
No pilot flame and control continues to spark	Thermocouple circuit wired incorrectly	Correct wiring
Pilot lights, control continues to spark, valve shuts down after 10-30 seconds	1. No spark at pilot burner 2. Loose/damaged wire	1. Rectify spark at pilot burner 2. Check interrupter and wires

IGNITION FUNCTIONAL CHECK 1

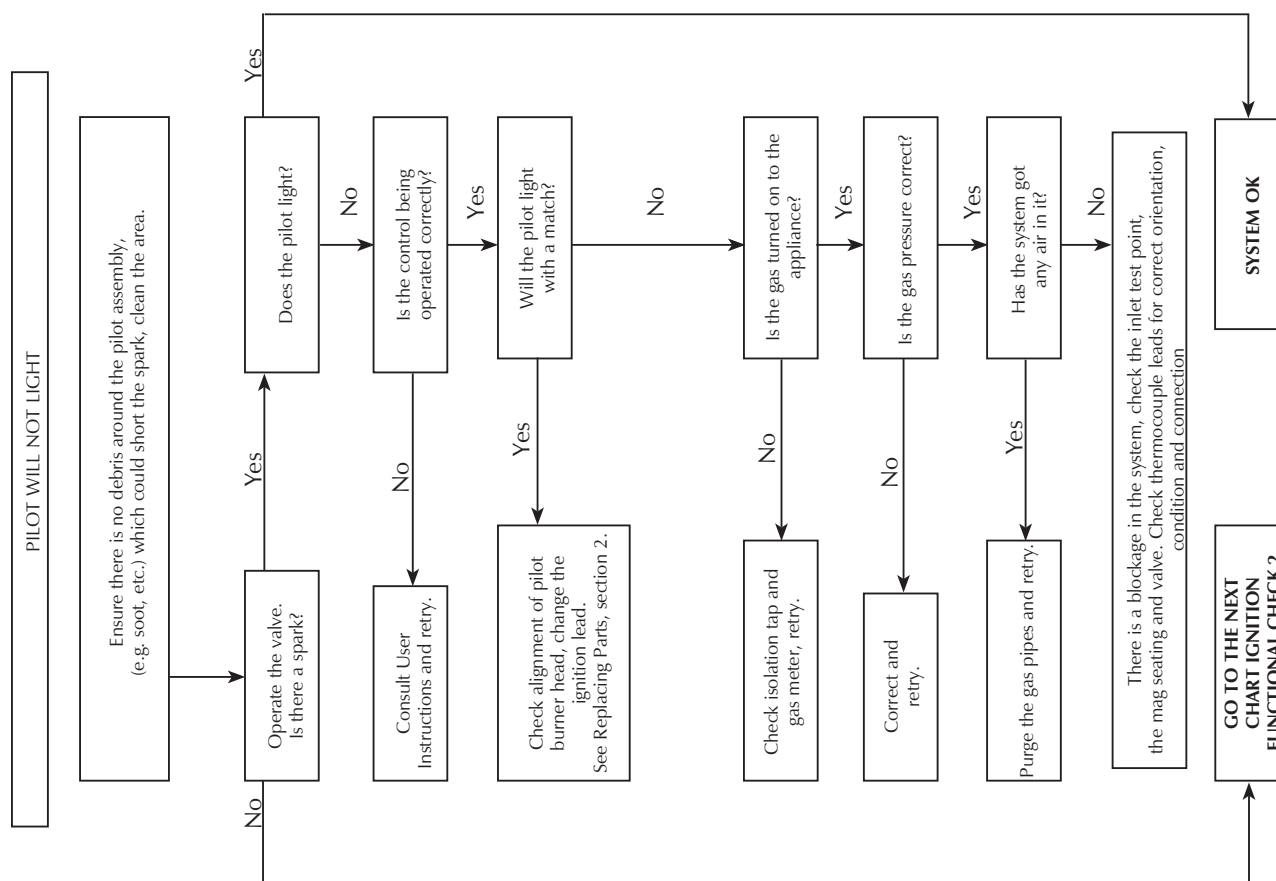

SERVICING INSTRUCTIONS

FAULT FINDING CHARTS

FLAME FAILURE FUNCTIONAL CHECK 3

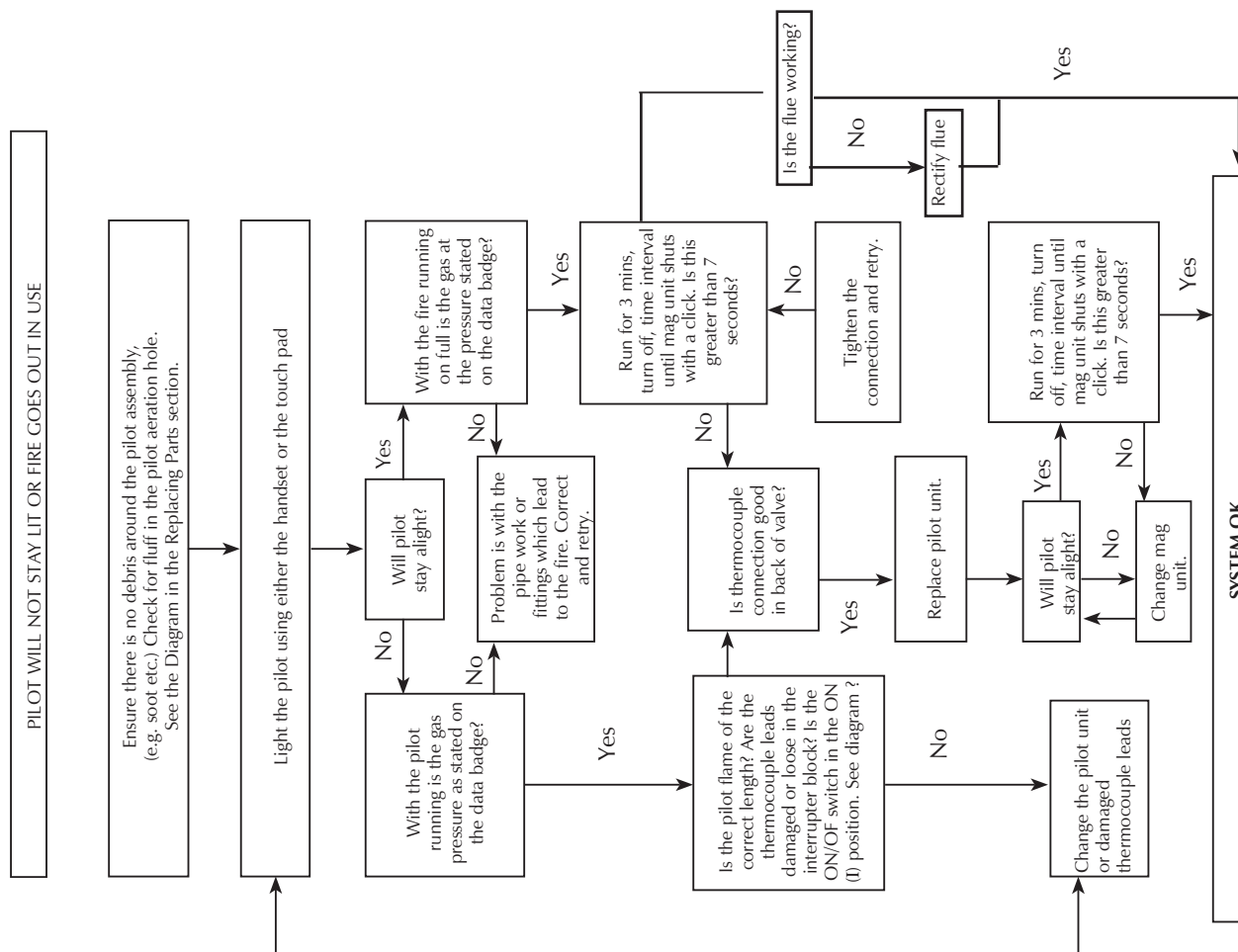

IGNITION FUNCTIONAL CHECK 2

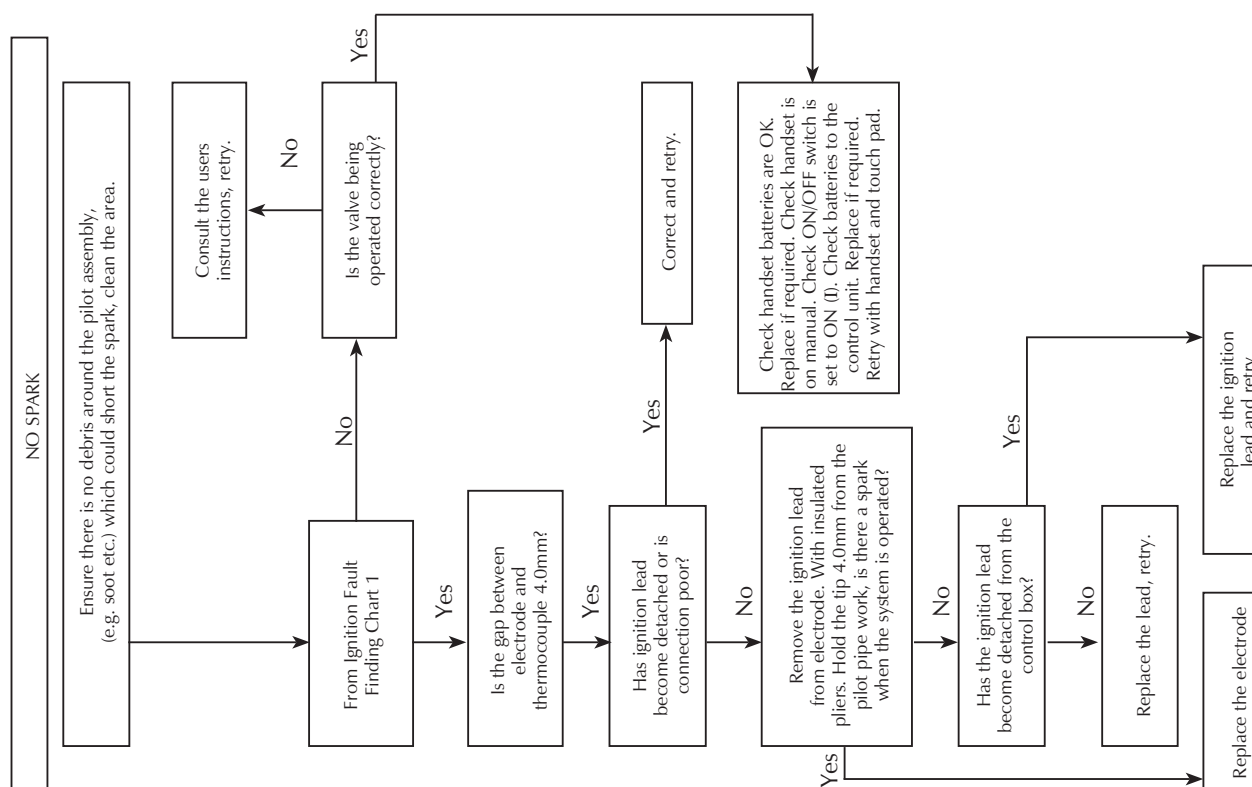

SERVICING INSTRUCTIONS

REPLACING PARTS

1. GENERAL

- 1.1 All main components can be replaced without removing the stove from its installation. **IT IS ESSENTIAL THAT THE GAS SUPPLY TO THE STOVE IS TURNED OFF AT THE ISOLATION DEVICE BEFORE PROCEEDING FURTHER.**

2. DECORATIVE FRAME

- 2.1 The same method is used to remove each frame.
- Lift the frame upwards off the four support brackets, Diagram 1

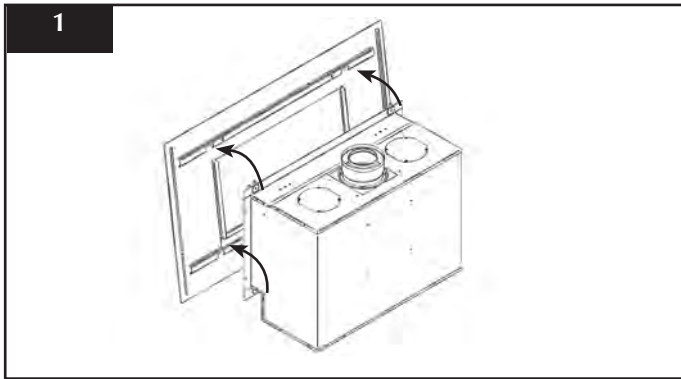

NOTE: THE STEEL FRAME IS HEAVY. TAKE CARE WHEN LIFTING

3. WINDOW FRAME ASSEMBLY

- 3.1 To open the glass door, use the allen key provided:
- Release the two window locks
- The lock needs to be moved from shut to open towards the outer edges, Diagram 2

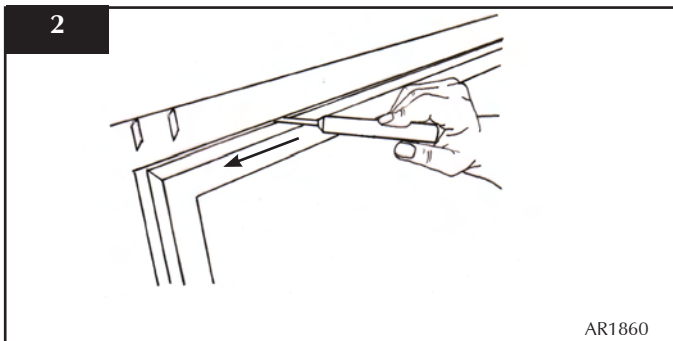

AR1860

- 3.2 To completely remove the glass front:
- Remove the securing spring clip from the bottom-right of the window frame, Diagram 3

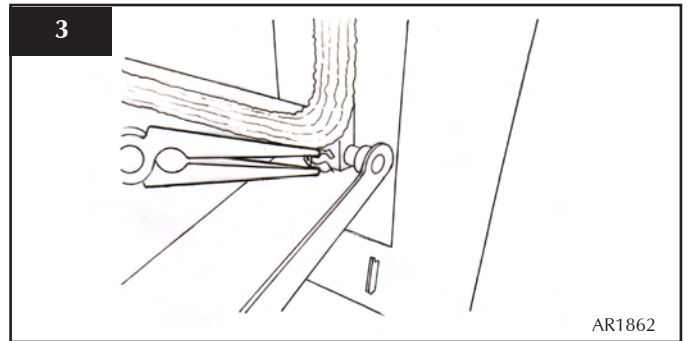

AR1862

- 3.3 With the window frame in an upright position:
- Slide the frame to the left so that it comes off the left hinge pin
- Still keeping the frame upright:
- Drop the left side down and forward slightly, Diagram 4

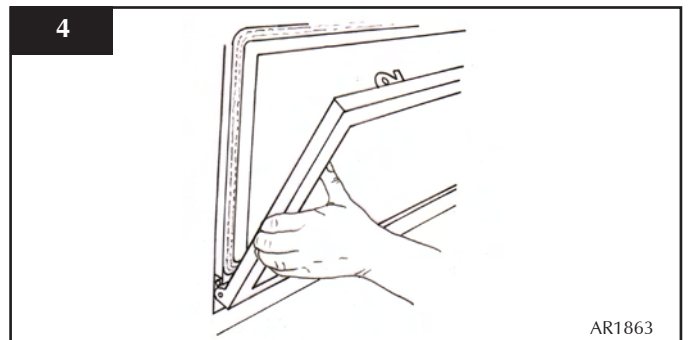

AR1863

- Slide the frame to the right so that the frame comes off the right hinge pin. The window frame is now free.
- Refit in reverse order

SERVICING INSTRUCTIONS

REPLACING PARTS

4. GLASS WINDOW

- 4.1 Remove the two clips and brackets from either side of the frame, Diagram 5

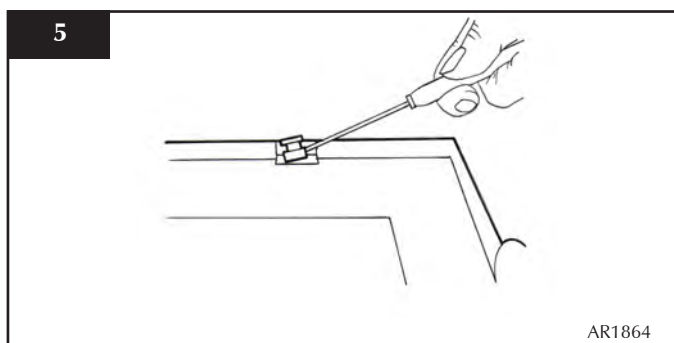

- Lift the glass clear from the lock bracket at the top of the frame and slide out

5. BLACK ENAMELLED PANELS

- 5.1 Hold the rear panel while sliding the side panels forward until clear of the appliance, Diagram 6

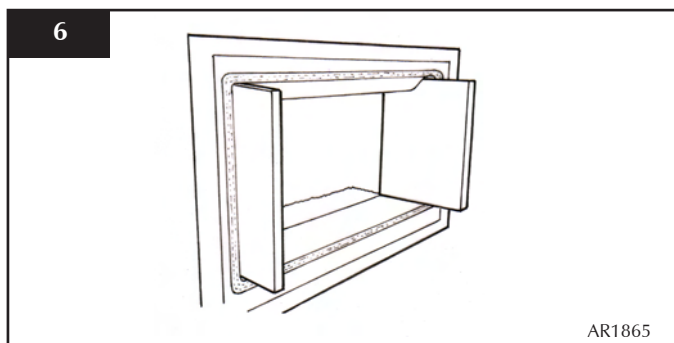

- Lift the bottom panel out of the appliance
 - Lift the panel from the appliance
- 5.2 • Lean the top of the rear panel forward and lift off the support rail
- 5.3 To reassemble the panels in reverse order:
- At an angle, slide the bottom of the back panel into place before the top edge is pushed back
 - Replace the lower panel
 - Replace the side panels
 - Replace the side panels

6. MAIN BURNER

- 6.1 To replace the main burner:
- Remove the stone pebbles from the burner (optional)
 - Remove the burner securing screw from the left side of the burner, Diagram 7

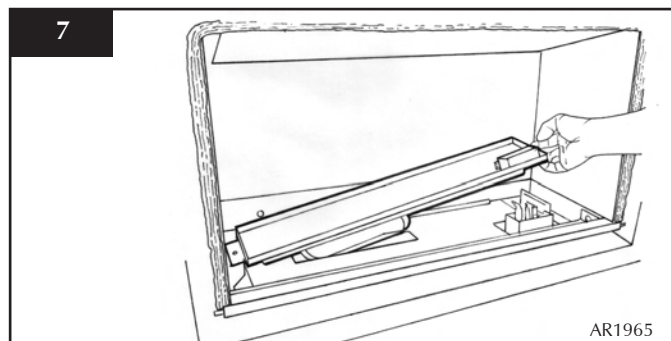

- Slide the burner fully to the left
- Lift the right side clear of the pilot, Diagram 8

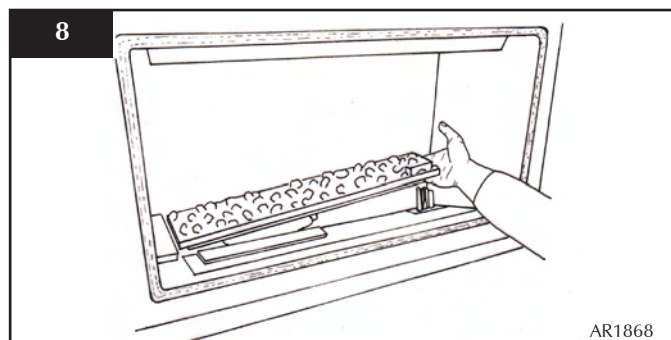

- Slide the burner to the right and out of its location
- Refit in reverse order

When refilling the stone pebbles, fill to the rim of the burner tray and flatten until level.

Ensure no stone pebbles fall into the pilot area.

SERVICING INSTRUCTIONS

REPLACING PARTS

7. MAIN CONTROL ASSEMBLY

7.1 To access the main control assembly, first remove:

- the decorative Steel frame (if fitted)
- window frame
- enamelled panels
- main burner
- splitter plate

7.2 To remove the splitter plater:

- Loosen the fixing screws (one each side)
- Lift the front of the plate off the screws
- Pull forward and upwards, Diagram 9

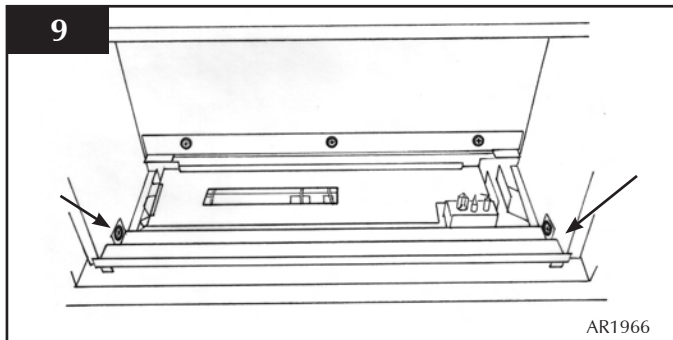

All components can be replaced without removing the control assembly.

8. PILOT UNIT ASSEMBLY

8.1 • Remove the screw retaining the pilot cover, Diagram 10

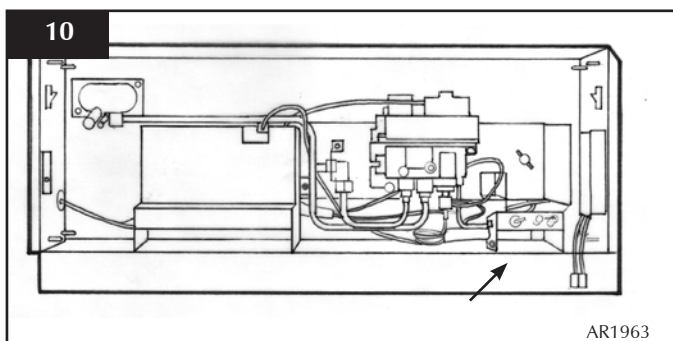

- Cut the cable tie retaining the vida flex sleeve and disconnect the ignition lead from the electrode

11

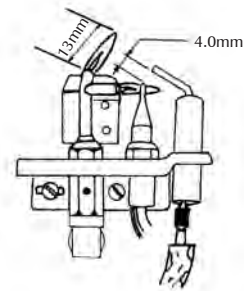

- Undo the pilot pipe and thermocouple
- Remove the two fixing screws and retain the vida flex sleeve which is needed for the replacement
- Replace in reverse order
- Ensure the thermocouple and ignition lead are threaded through the vida flex and secured with a cable tie
- There is a cut out in the pilot shroud to hold the vida flex.
- Check for gas leaks

9. IGNITION LEAD

- 9.1
- Cut the cable tie securing the vida flex and disconnect the ignition lead from the electrode
 - Pull the lead through the vida flex
 - Cut the remaining cable tie and disconnect the lead from the control box, Diagram 12

12

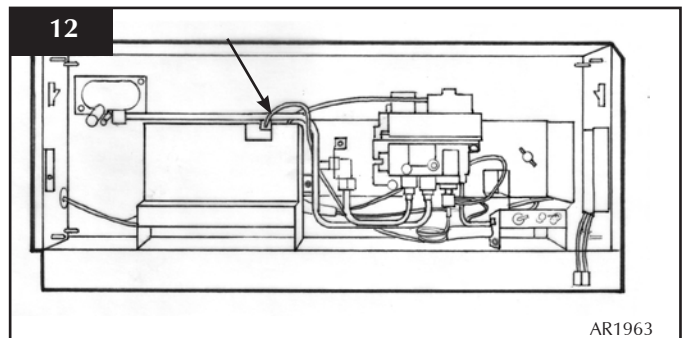

- Replace in reverse order
- Ensure the lead is passed through the vida flex, secured with a cable tie and the red insulated end is attached to the electrode

NOTE: DO NOT ROUTE THE IGNITION LEAD IN THE VICINITY OF THE ANTENNA ON THE CONTROL BOX. THIS DAMAGES THE COMPONENTS.

SERVICING INSTRUCTIONS

REPLACING PARTS

10. GAS VALVE

- 10.1 To change the gas valve:
- Disconnect the inlet pipe
 - Disconnect the feed pipe
 - Disconnect the pilot pipe
 - Disconnect the thermocouple, thermo current wires and the interrupter block
 - Remove the two screws and rotate the valve to access the front
- The cable can now be removed from the valve, Diagram 13

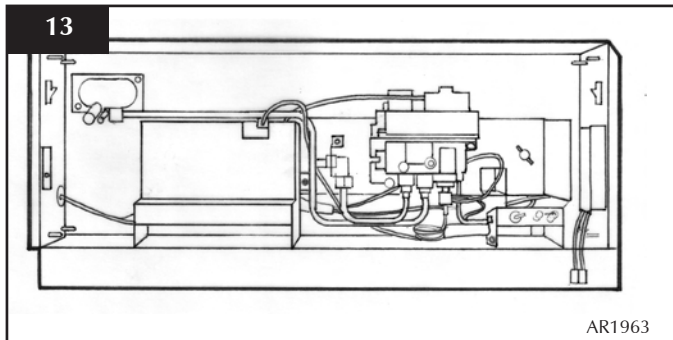

- Reassemble in reverse order and check for leaks

11. MAGNETIC SAFETY VALVE

- 11.1 To replace the magnetic safety valve:
- Undo the thermocouple from the interrupter block and remove the two thermo current cables
 - Unscrew the interrupter block from the back of the valve
 - Undo the silver magnetic valve retaining nut on the back of the valve.
 - Gently tap out the mag valve
 - Replace with a new unit
 - Reassemble in reverse order
 - Check for leaks

12. CONTROL BOX

- Remove the cover fixing screw, Diagram 14

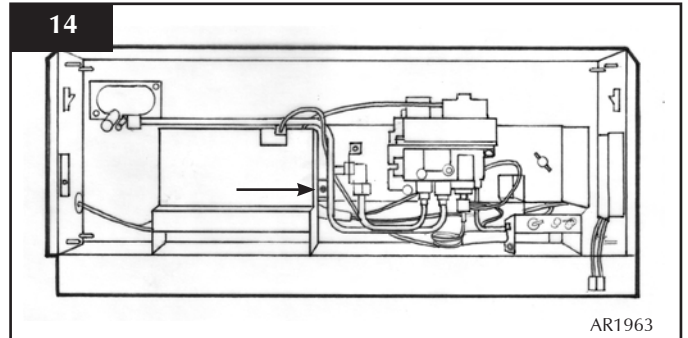

- Remove the two thermo current cables by removing the two screws, Diagram 15
- Remove the ignition lead, Diagram 15
- Remove the eight loom wire from the control box, Diagram 15

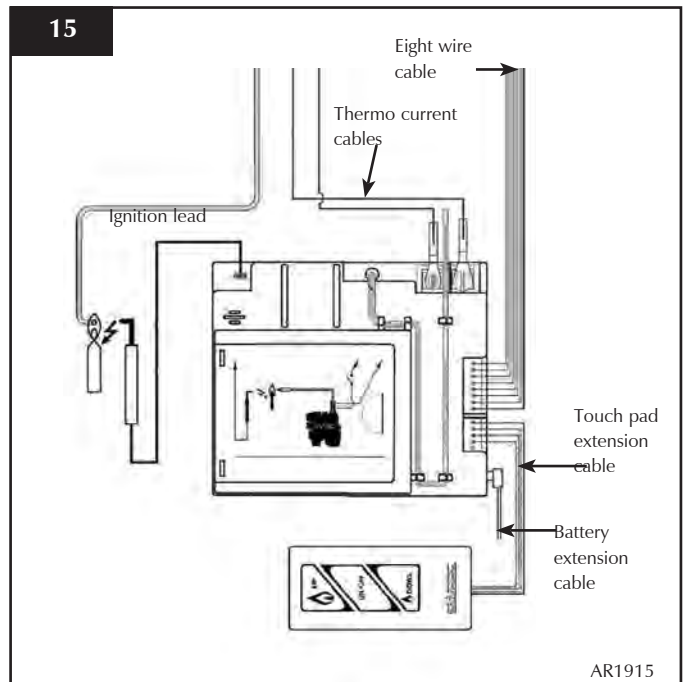

- Remove the battery extension cable, Diagram 15
 - Remove the touch pad extension cable
- The control box can now be replaced.
- After replacing the control box you may need to reprogram the handset:
- Press and hold the reset button on the control box until you hear two signals. After the second longer signal:
 - Release the reset button and within 20 seconds
 - Press the DOWN button on the handset until you hear an additional long signal confirming the new code
 - Refer to separate handset instructions to set new code

SERVICING INSTRUCTIONS

REPLACING PARTS

13. MAIN INJECTOR

- 13.1 To change the main injector:
- Undo the injector feed pipe
 - Undo the lock nut from the injector and remove the silencer
 - Replace with the correct size injector
 - Check for leaks

14. PRIMARY AERATION PLATE

NOT ALL MODELS HAVE AERATION PLATES. REFER TO NOTE AT BEGINNING OF INSTALLATION INSTRUCTIONS.

- 9.1 Remove the burner module as described in *Replacing Parts Section 6*.
- 9.2 Remove the fixing screw and slide the plate off the venturi.
- 9.3 Replace with the correct size plate and secure with the screw. Ensure the lower edge of the plate is located over the venturi flange, Diagram 16.

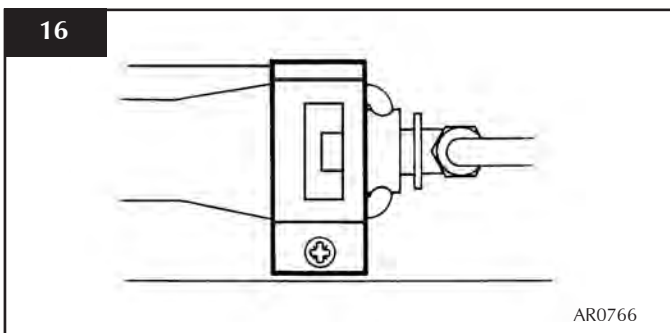

15. DEBRIS AREA ACCESS

- Remove the Steel frame (if fitted)
- Remove the glass door assembly
- Remove the enamelled panels
- Remove the burner and splitter plate
- Isolate the gas supply
- Disconnect the isolating device from the inlet pipe on the appliance
- Remove the seven screws from the front of the loose box, Diagram 17

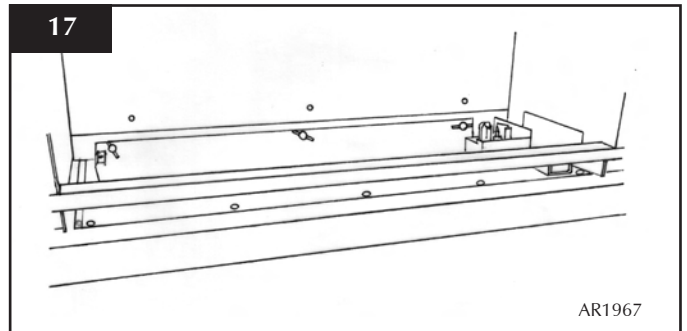

- Remove the three screws from the rear panel
- Lift the panel to disengage the locating brackets, Diagram 17
- Remove the three wing nuts from the rear of the box, Diagram 17

To release the box from the main body:

- Rotate the front of the box upwards and draw the box forward off the rear studs
- Ensure the gas pipe passes through the silicon seal in the base of the box

Any debris can now be removed through the aperture.

- Replace in reverse order taking care not to damage the gas pipe when replacing the box

16. CHANGING BETWEEN GAS TYPES

In order to change between gas types, it will be necessary to change the following items:

Burner Unit

Pilot

Control Valve

Injector

Aeration Plate (if required)

Data badge

A kit of parts is available for this, always quote the Model number and Serial number when ordering any spare parts.

NOTE: THE CONTROL VALVE IS FACTORY PRESET FOR THE CORRECT GAS TYPE AND MODEL, A NEW UNIT WILL NEED TO BE ORDERED WHEN CHANGING BETWEEN GAS TYPES.

SERVICING INSTRUCTIONS

REPLACING PARTS

17. PRESSURE AND LEAK TESTING THE APPLIANCE

14.1 Follow *Section 7, Main Control Assembly, 7.1 and 7.2*

- Access to the pressure test point can now be reached, Diagram 18

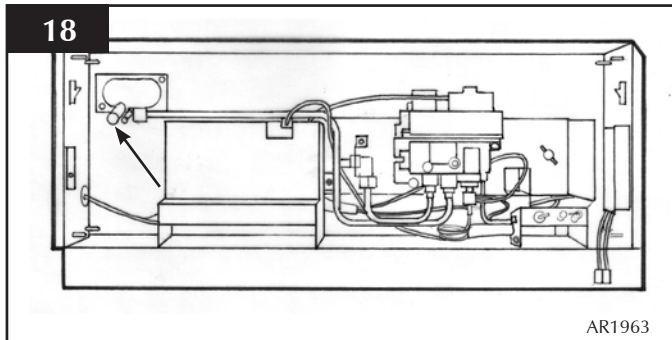

Refer to paragraph 4.11 of the *Installation Instructions* to check gas pressure

- Light the appliance and spray any joints with leak detector fluid
- Tighten joints or replace as required

SERVICING INSTRUCTIONS

REPLACING PARTS

18. SHORT SPARES LIST

COMPONENT	Studio 1 CF		Studio 2 CF	
	NG	LPG	NG	LPG
PILOT	PI0036	PI0037	PI0036	PI0037
MAIN INJECTOR	IN0028	IN0040	IN0029	IN0041
BURNER ASSEMBLY	GZ6714	GZ6759	GZ6861	GZ6860
AERATION PLATE	G20 - GZ3869	G30 - N/A	G20-GZ3868	G30 - N/A
	G25 - GZ4333	G31 - N/A	G25 - GZ3270	G31 - GZ3866
MAG UNIT	GC0092		GC0092	
IGNITION LEAD	GC0125		GC0125	
GAS VALVE	GC0123		GC0123	
CONTROL BOX	GC0129		GC0129	
REMOTE CONTROL	GC0131		GC0131	
INTERRUPTER BLOCK	GC0124		GC0124	
THERMO CURRENT CABLE	GC0126		GC0126	
THERMO CURRENT CABLE SWITCH	GC0128		GC0128	
TOUCH PAD AND LEAD	GC0130		GC0130	
BATTERY HOLDER	EL0410		EL0410	
BATTERY HOLDER CABLE	GC0127		GC0127	
CONTROL BOX/VALVE CABLE	GC0133		GC0133	
REAR ENAMELLED PANEL	GZ6488		GZ6867	
SIDE ENAMELLED PANEL	GZ6489		GZ6489	
BASE ENAMELLED PANEL	GZ6490		GZ6866	
STONE PEBBLES	CE0647		CE0579	

SERVICE RECORDS

1ST SERVICE

Date of Service:.....
Next Service Due:.....
Signed:.....
Dealer's Stamp/CORGI Registration Number

2ND SERVICE

Date of Service:.....
Next Service Due:.....
Signed:.....
Dealer's Stamp/CORGI Registration Number

3RD SERVICE

Date of Service:.....
Next Service Due:.....
Signed:.....
Dealer's Stamp/CORGI Registration Number

4TH SERVICE

Date of Service:.....
Next Service Due:.....
Signed:.....
Dealer's Stamp/CORGI Registration Number

5TH SERVICE

Date of Service:.....
Next Service Due:.....
Signed:.....
Dealer's Stamp/CORGI Registration Number

6TH SERVICE

Date of Service:.....
Next Service Due:.....
Signed:.....
Dealer's Stamp/CORGI Registration Number

7TH SERVICE

Date of Service:.....
Next Service Due:.....
Signed:.....
Dealer's Stamp/CORGI Registration Number

8TH SERVICE

Date of Service:.....
Next Due:.....
Signed:.....
Dealer's Stamp/CORGI Registration Number

9TH SERVICE

Date of Service:.....
Next Service Due:.....
Signed:.....
Dealer's Stamp/CORGI Registration Number

10TH SERVICE

Date of Service:.....
Next Service Due:.....
Signed:.....
Dealer's Stamp/CORGI Registration Number

Gazco Limited, Osprey Road, Sowton Industrial Estate, Exeter, Devon, England EX2 7JG
Tel: (01392) 261999 Fax: (01392) 444148 E-mail: info@gazco.com

A member of the Stovax Group