

INSTALLATION AND SERVICE MANUAL

high efficiency, separated combustion gas-fired unit heaters

model PTC

Model PTC



All models approved for use in California by the CEC and in Massachusetts. Unit heater is certified for residential (size 110 and smaller only) and commercial applications.

™ Effinity⁹³, Conservicore, and any combination of these names either together or with other words is trademarked by Modine Manufacturing Co.

FOR YOUR SAFETY

The use and storage of gasoline or other flammable vapors and liquids in open containers in the vicinity of this appliance is hazardous.

! WARNING

1. Improper installation, adjustment, alteration, service, or maintenance can cause property damage, injury, or death and could cause exposure to substances which have been determined by various state agencies to cause cancer, birth defects, or other reproductive harm. Read the installation, operating, and maintenance instructions thoroughly before installing or servicing this equipment.
2. Do not locate ANY gas-fired units in areas where chlorinated, halogenated, or acidic vapors are present in the atmosphere. These substances can cause premature heat exchanger failure due to corrosion, which can cause property damage, serious injury, or death.

IMPORTANT

The use of this manual is specifically intended for a qualified installation and service agency. All installation and service of these units must be performed by a qualified installation and service agency.

FOR YOUR SAFETY

WHAT TO DO IF YOU SMELL GAS:

1. Open windows.
2. Do not try to light any appliance.
3. Do not touch any electrical switch; do not use any phone in your building.
4. Extinguish any open flame.
5. Immediately call your gas supplier from a neighbor's phone. Follow the gas supplier's instructions. If you can not reach your gas supplier, call your fire department.

Inspection on Arrival

1. Inspect unit upon arrival. In case of damage, report it immediately to the transportation company and your local Modine sales representative.
2. Check rating plate on unit to verify that power supply meets available electric power at the point of installation.
3. Inspect unit upon arrival for conformance with description of product ordered (including specifications where applicable).

Table of Contents

Inspection on Arrival	1
Special Precautions	2
SI (Metric) Conversion Factors	3
Before You Begin	3
Unit Location	4
Combustible Material and Service Clearances	4
Unit Mounting	5
Installation	6
Venting	6
Gas Connections	14
Electrical	15
Operation	16
Unit Components	17
Performance Data/Deflector Hoods	18
Dimensions	19
Service/Troubleshooting	20
Serial/Model Number/Replacement Parts	23
Commercial Warranty	Back Cover

SPECIAL PRECAUTIONS

SPECIAL PRECAUTIONS

THE INSTALLATION AND MAINTENANCE INSTRUCTIONS IN THIS MANUAL MUST BE FOLLOWED TO PROVIDE SAFE, EFFICIENT AND TROUBLE-FREE OPERATION. IN ADDITION, PARTICULAR CARE MUST BE EXERCISED REGARDING THE SPECIAL PRECAUTIONS LISTED BELOW. FAILURE TO PROPERLY ADDRESS THESE CRITICAL AREAS COULD RESULT IN PROPERTY DAMAGE OR LOSS, PERSONAL INJURY, OR DEATH. THESE INSTRUCTIONS SUBJECT TO ANY MORE RESTRICTIVE LOCAL OR NATIONAL CODES.

HAZARD INTENSITY LEVELS

1. **DANGER:** Indicates an imminently hazardous situation which, if not avoided, WILL result in death or serious injury.
2. **WARNING:** Indicates a potentially hazardous situation which, if not avoided, COULD result in death or serious injury.
3. **CAUTION:** Indicates a potentially hazardous situation which, if not avoided, MAY result in minor or moderate injury.
4. **IMPORTANT:** Indicates a situation which, if not avoided, MAY result in a potential safety concern.

DANGER

Appliances must not be installed where they may be exposed to a potentially explosive or flammable atmosphere.

WARNING

1. Gas fired heating equipment must be vented - do not operate unvented.
2. A built-in power exhauster is provided - additional external power exhausters are not required or permitted.
3. Unit must not be common vented with other appliances.
4. If an existing heater is being replaced, the vent system must meet the requirements specified in this manual. Improperly sized or constructed venting systems can result in vent gas leakage or the formation of condensate. Failure to follow these instructions can result in injury or death.
5. In locations where the outside air temperature falls below freezing, icicles may form on horizontal vent terminations from the condensate formed in the vent system. Locate the vent termination where a falling icicle will not be a hazard.
6. Installation must conform with local building codes or in the absence of local codes, the National Fuel Gas Code, ANSI Z223.1 (NFPA 54) - latest edition. In Canada installation must be in accordance with CSA-B149.1.
7. Do not install PVC pipe near high temperature sources of heat exceeding 140° F that could damage the pipe and cause hazardous leaks of products of combustion or water into the space.
8. All field gas piping must be pressure/leak tested prior to operation. Never use an open flame. Use a soap solution or equivalent for testing.
9. Gas pressure to appliance controls must never exceed 14" W.C. (1/2 psi).
10. To reduce the opportunity for condensation, the minimum sea level input to the appliance, as indicated on the serial plate, must not be less than 5% below the rated input, or 5% below the minimum rated input of dual rated units.
11. Disconnect power supply before making wiring connections to prevent electrical shock and equipment damage.
12. All appliances must be wired strictly in accordance with the wiring diagram furnished with the appliance. Any wiring different from the wiring diagram could result in a hazard to persons and property.

WARNING

13. Any original factory wiring that requires replacement must be replaced with wiring material having a temperature rating of at least 105°C.
14. Ensure that the supply voltage to the appliance, as indicated on the serial plate, is not 5% greater than or 5% less than the rated voltage.
15. When servicing or repairing this equipment, use only factory-approved service replacement parts. A complete replacements parts list may be obtained by contacting the factory. Refer to the rating plate on the appliance for complete appliance model number, serial number, and company address. Any substitution of parts or controls not approved by the factory will be at the owner's risk.

CAUTION

1. All literature shipped with this unit should be kept for future use for servicing or service diagnostics. Do not discard any literature shipped with this unit.
2. Consult piping, electrical, and venting instructions in this manual before final installation.
3. Do not attach ductwork, air filters, or polytubes to any propeller unit heater.
4. Clearances to combustible materials are critical. Be sure to follow all listed requirements.
5. Heaters are designed for use in heating applications with ambient temperatures between 40°F and 80°F. Heaters should not be used in applications where the heated space temperature is below 40°F. The combination of low space and combustion air temperatures may result in condensate freezing in the secondary heat exchanger and/or condensate drain.
6. Do not install unit outdoors.
7. In garages or other sections of aircraft hangars such as offices and shops that communicate with areas used for servicing or storage, keep the bottom of the unit at least 7' above the floor unless the unit is properly guarded to provide user protection from moving parts and interior surface temperatures that can cause serious burns if touched. In parking garages, the unit must be installed in accordance with the standard for parking structures ANSI/NFPA 88A, and in repair garages the standard for repair garages NFPA 30A. In Canada, installation of heaters in airplane hangars must be in accordance with the requirements of the enforcing authority, and in public garages in accordance with the current CSA-B149 codes.
8. In aircraft hangars, keep the bottom of the unit at least 10' from the highest surface of the wings or engine enclosure of the highest aircraft housed in the hangars and in accordance with the requirements of the enforcing authority and/or NFPA 409 - latest edition.
9. Installation of units in high humidity or salt water atmospheres will cause accelerated corrosion resulting in a reduction of the normal life of the units.
10. Do not install units below 7' measured from the bottom of the unit to the floor in commercial applications (unless unit is properly guarded to provide user protection from moving parts and interior surface temperatures that can cause serious burns if touched) and 5' measured from the bottom of the unit to the floor in residential applications (sizes 110 and smaller only).
11. Be sure no obstructions block air intake and discharge of unit heaters.

SPECIAL PRECAUTIONS / SI (METRIC) CONVERSION FACTORS

! CAUTION

12. The minimum distance from combustible material is based on the combustible material surface not exceeding 160°F. Clearance from the top of the unit may be required to be greater than the minimum specified if heat damage, other than fire, may occur to materials above the unit heater at the temperature described.
13. Allow 18" of clearance at rear (or 12" beyond end of motor at rear of unit, whichever is greater) and access side to provide ample air for proper operation of fan.
14. The concentric vent adapter box must be installed inside of the structure or building. Do not install this box on the exterior of a building or structure.
15. Purging of air from gas supply line should be performed as described in the National Fuel Gas Code, ANSI Z223.1 (NFPA 54) - latest edition, or in Canada in CSA-B149 codes.
16. When leak testing the gas supply piping system, the appliance and its combination gas control must be isolated during any pressure testing in excess of 14" W.C. (1/2 psi).
17. The unit should be isolated from the gas supply piping system by closing its field installed manual shut-off valve. This manual shut-off valve should be located within 6' of the heater.
18. Turn off all gas before installing appliance.
19. Check the gas inlet pressure at the unit upstream of the combination gas control. The inlet pressure should be 6-7" W.C. on natural gas or 12-14" W.C. on propane. If inlet pressure is too high, install an additional pressure regulator upstream of the combination gas control.
20. Service or repair of this equipment must be performed by a qualified service agency.
21. Do not attempt to reuse any mechanical or electronic ignition controller which has been wet. Replace defective controller.

IMPORTANT

1. To prevent premature heat exchanger failure, do not locate ANY gas-fired appliances in areas where corrosive vapors (i.e. chlorinated, halogenated, or acidic) are present in the atmosphere.
2. To prevent premature heat exchanger failure, the input to the appliance as indicated on the serial plate, must not exceed the rated input by more than 5%.
3. Start-up and adjustment procedures should be performed by a qualified service agency.
4. To check most of the Possible Remedies in the troubleshooting guide listed in Table 21.1 refer to the applicable sections of the manual.

BEFORE YOU BEGIN

! CAUTION

1. All literature shipped with this unit should be kept for future use for servicing or service diagnostics. Leave manual with the owner. Do not discard any literature shipped with this unit.
2. Consult piping, electrical, and venting instructions in this manual before final installation.
3. Do not attach ductwork, air filters, or polytubes to any propeller unit heater.

In the U.S., the installation of these units must comply with the the National Fuel Gas Code, ANSI Z223.1 (NFPA 54) - latest edition, or in other applicable local building codes. In Canada, the installation of these units must comply with local plumbing or waste water codes and other applicable codes and with the current code CSA-B149.1.

1. All installation and service of these units must be performed by a qualified installation and service agency only as defined in ANSI Z223.1 (NFPA 54) - latest edition or in Canada by a licensed gas fitter.
2. This unit is certified with the controls furnished. For replacements parts, please order according to the replacement parts list on serial plate. Always know your model and serial numbers. Modine reserves the right to substitute other authorized controls as replacements.
3. Unit is balanced for correct performance. Do not alter fan or operate motors at speeds below what is shown in this manual.
4. Information on controls is supplied separately.

SI (Metric) Conversion Factors

To Convert	Multiply By	To Obtain
"W.C.	0.249	kPa
°F	(°F-32) x 5/9	°C
BTU	1.06	kJ
Btu/ft ³	37.3	kJ/m ³
Btu/hr	0.000293	kW
CFH (ft ³ /hr)	0.000472	m ³ /min
CFH (ft ³ /hr)	0.00000787	m ³ /s
CFM (ft ³ /min)	0.0283	m ³ /min
CFM (ft ³ /min)	0.000472	m ³ /s
feet	0.305	m
Gal/Hr.	0.00379	m ³ /hr
Gal/Hr.	3.79	l/hr
gallons	3.79	l
Horsepower	746	W
inches	25.4	mm
pound	0.454	kg
psig	6.89	kPa
psig	27.7	"W.C.

UNIT LOCATION

UNIT LOCATION

⚠ DANGER

Appliances must not be installed where they may be exposed to a potentially explosive or flammable atmosphere.

⚠ CAUTION

- Clearances to combustible materials are critical. Be sure to follow all listed requirements.
- Heaters are designed for use in heating applications with ambient temperatures between 40°F and 80°F. Heaters should not be used in applications where the heated space temperature is below 40°F. The combination of low space and combustion air temperatures may result in condensate freezing in the secondary heat exchanger and/or condensate drain.
- Do not install unit outdoors.
- In garages or other sections of aircraft hangars such as offices and shops that communicate with areas used for servicing or storage, keep the bottom of the unit at least 7' above the floor unless the unit is properly guarded to provide user protection from moving parts and interior surface temperatures that can cause serious burns if touched. In parking garages, the unit must be installed in accordance with the standard for parking structures ANSI/NFPA 88A, and in repair garages the standard for repair garages NFPA 30A. In Canada, installation of heaters in airplane hangars must be in accordance with the requirements of the enforcing authority, and in public garages in accordance with the current CSA-B149 codes.
- In aircraft hangars, keep the bottom of the unit at least 10' from the highest surface of the wings or engine enclosure of the highest aircraft housed in the hangars and in accordance with the requirements of the enforcing authority and/or NFPA 409 - latest edition.
- Installation of units in high humidity or salt water atmospheres will cause accelerated corrosion resulting in a reduction of the normal life of the units.

IMPORTANT

To prevent premature heat exchanger failure, do not locate ANY gas-fired appliances in areas where corrosive vapors (i.e. chlorinated, halogenated, or acidic) are present in the atmosphere.

Location Recommendations

- When locating the heater, consider general space and heating requirements, availability of gas and electrical supply, and proximity to vent locations and condensate drain lines.
- When locating units, it is important to consider that the combustion air and exhaust vent piping must be connected to the outside atmosphere. Vent terminals should be located adjacent to one another. Maximum equivalent vent lengths are listed in "Section A - General Instruction - All Units" of the Venting instructions.
- Be sure the structural support at the unit location site is adequate to support the unit's weight. Refer to page 19 for unit weights. For proper operation the unit must be installed in a level horizontal position.

Figure 4.1 - Combustible Material and Service Clearances

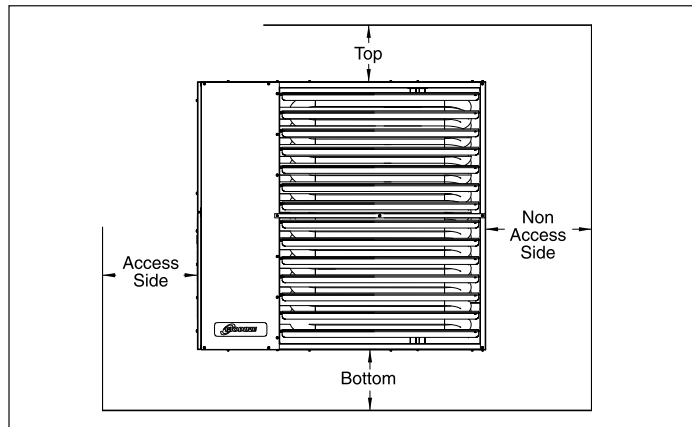

Table 4.1 - Clearances

Unit Side	Clearance To Combustible Materials	Recommended Service Clearance
Top and Bottom	6"	6"
Access Side	6"	18"
Non-Access Side	6"	18"
Rear	18"	18"
Vent Connector	6"	6"

- Do not install units in locations where the flue products can be drawn into the adjacent building openings such as windows, fresh air intakes, etc.
- Be sure that the minimum clearances to combustible materials and recommended service clearances are maintained. Units are designed for installation with the minimum clearances as shown in Figure 4.1 and Table 4.1. Clearance from the top of the unit may be required to be greater than 6" if heat damage other than fire could result (such as material distortion or discoloration).
- Do not install units in locations exposed to water spray, rain, or dripping water.
- Mounting Height (measured from bottom of unit) at which unit heaters are installed is critical. Refer to mounting height and heat throw data on page 18 of this manual. The maximum mounting height for any unit is that height above which the unit will not deliver heated air to the floor.

Sound and Vibration Levels

All standard mechanical equipment generates some sound and vibration that may require attenuation. Libraries, private offices and hospital facilities will require more attenuation, and in such cases, an acoustical consultant may be retained to assist in the application. Locating the equipment away from the critical area is desirable within ducting limitations. Generally, a unit should be located within 15 feet of a primary support beam. Smaller deflections typically result in reduced vibration and noise transmission.

UNIT MOUNTING

! CAUTION

1. Do not install units below 7' measured from the bottom of the unit to the floor in commercial applications (unless unit is properly guarded to provide user protection from moving parts and interior surface temperatures that can cause serious burns if touched) and 5' measured from the bottom of the unit to the floor in residential applications (sizes 110 and smaller only).
2. Be sure no obstructions block air intake and discharge of unit heaters.
3. The minimum distance from combustible material is based on the combustible material surface not exceeding 160°F. Clearance from the top of the unit may be required to be greater than the minimum specified if heat damage, other than fire, may occur to materials above the unit heater at the temperature described.
4. Allow 18" clearance at rear (or 12" beyond end of motor at rear of unit, whichever is greater) and access side to provide ample air for proper operation of fan.

1. Be sure the means of suspension is adequate to support the weight of the unit (see page 19 for unit weights).
2. For proper operation, the unit must be installed in a level horizontal position from front to back and side to side.
3. Clearances to combustibles as specified in Table 4.1 must be strictly maintained.
4. All standard units are shipped fully boxed. Larger units are also supplied with skid supports on the bottom of the box. The larger units may be lifted from the bottom by means of a fork lift or other lifting device only if the shipping support skids are left in place and the forks support the whole depth of the unit. If the unit must be lifted from the bottom for final installation without the carton in place, be sure to properly support the unit over its entire length and width to prevent damage. When lifting units, make sure the load is balanced.
5. Units have four mounting holes and can be mounted with 3/8-16 threaded rod as follows:
 - On each piece of threaded rod used, screw a nut a distance of about one inch onto the end of the threaded rods that will be screwed into the unit heater.
 - Place a washer over the end of the threaded rod and screw the threaded rod into the unit heater weld nuts on the top of the heater at least 5 turns, and no more than 10 turns. Tighten the nut first installed onto the threaded rod to prevent the rod from turning.
 - Drill holes into a steel channel or angle iron at the same center-line dimensions as the heater that is being installed. The steel channels or angle iron pieces need to span and be fastened to appropriate structural members.
 - Cut the threaded rods to the preferred length, place them through the holes in the steel channel or angle iron and secure with washers and lock nuts or lock washers and nuts. A double nut arrangement can be used here instead of at the unit heater (a double nut can be used both places but is not necessary).
 - Do not install standard unit heaters above the maximum mounting height shown in Tables 18.1 or 18.2.

Alternate Suspension Methods

A pipe hanger adapter kit, shown in Figure 5.1 is available as an accessory. One kit consists of two drilled 3/4" IPS pipe caps and two 3/8 - 16 x 1-3/4" capscrews to facilitate threaded pipe suspension. Two kits would be required for PTC units.

Figure 5.1 - Unit Heater Suspension Methods

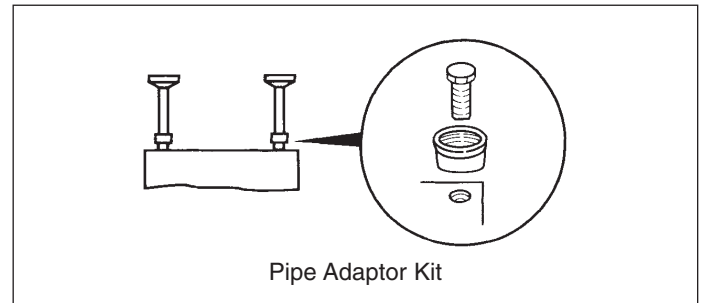

Also available is a 2-point mounting kit for installations where the ceiling structure only allows for two mounting points. Refer to the latest revision of literature #6-574 for instructions.

INSTALLATION - VENTING

⚠ WARNING

1. Gas fired heating equipment must be vented - do not operate unvented.
2. A built-in power exhauster is provided - additional external power exhausters are not required or permitted.
3. Unit must not be common vented with other appliances.
4. If an existing heater is being replaced, the vent system must meet the requirements specified in this manual. Improperly sized or constructed venting systems can result in vent gas leakage or the formation of condensate. Failure to follow these instructions can result in injury or death.
5. In locations where the outside air temperature falls below freezing, icicles may form on horizontal vent terminations from the condensate formed in the vent system. Locate the vent termination where a falling icicle will not be a hazard.
6. Do not install PVC pipe near high temperature sources of heat exceeding 140° F that could damage the pipe and cause hazardous leaks of products of combustion or water into the space.

Model PTC unit heaters must be vented with the proper passageway as described in these instructions to convey flue gases from the unit or the vent connector to the outside atmosphere. The heaters must also have a separate combustion air intake pipe to bring in fresh air for combustion from the outside atmosphere.

The venting instructions are organized in sections, based on installation type. The sections are identified as follows:

Instructions Section	Applicable Installation Instructions by Vent System Type
A	General Instructions for ALL installations
B	VERTICAL vent systems ①
C	HORIZONTAL vent systems ①
D	Additional requirements for HORIZONTAL AND VERTICAL CONCENTRIC vent systems ②

① The differences between Vertical and Horizontal vent systems in 2-Pipe or Concentric Vent configurations will be identified in "Section A - General Instructions – All Units".

② For 2-Pipe installations, only sections B or C are required. For a Concentric Vent installation, section B or C must be followed, along with additional instructions shown in section D.

Section A - General Instructions - All Units

- A1. If the unit heater being installed is replacing existing equipment and using the existing vent system from that equipment, inspect the venting system for proper materials, size and horizontal pitch, as required in these instructions. Determine that there is no blockage or restriction, leakage, corrosion and other deficiencies, which could cause an unsafe condition.
- A2. Model PTC units feature high thermal efficiency and are certified as Category IV vented appliances. The units will produce condensate during operation. Both the heater and the vent system must be connected to a condensate removal drain, which is detailed in this manual.
- A3. Vent pipe must be Schedule 40 PVC pipe. In Canada, all PVC vent pipe must be approved to ULC S636. The combustion air inlet pipe must be Schedule 40 PVC for model sizes 260 and smaller. For model size 310, the combustion air inlet pipe must be sealed, single wall galvanized steel or other suitable corrosion resistant material.

- A4. All heaters come with factory installed vent and combustion air adapters for attaching the vent and combustion air inlet piping to the heater (Refer to Table 6.1 for applicable connector sizes).

Table 6.1 - Combustion Air & Vent Pipe Connection

Model Size	Combustion Air Inlet		Flue Exhaust Outlet	
	Diameter	Material	Diameter	Material
85-135 ①	3"	PVC	3"	PVC
155/156-260	4"	PVC	4"	PVC
310	6"	Steel	4"	PVC

① Size 110 and smaller maximum vent length is 25 feet.

- A5. Attach the vent pipe to the unit heater vent connection adapter by sliding the pipe into the rubber exhaust pipe coupling located on the back of the unit. Tighten the pipe clamp to secure the vent pipe to the unit. Vent pipe must not be smaller than the connector size.
- A6. Attach the combustion air inlet pipe to the unit heater inlet air connection adapter with 3 corrosion resistant screws. (Drill pilot holes through the pipe and adapter prior to screwing in place). Pipe must not be smaller than the connector size.
- A7. Limit the total equivalent vent pipe length to a minimum of 5' and a maximum of 50' (25' for sizes 110 and smaller), making the vent system as straight as possible. The equivalent length of a 3" or 4" 90° elbow is 6' and for a 6" 90° elbow is 7'. Two 45° elbows are equivalent to one 90° elbow. The combustion air inlet pipe length should be approximately the same as the vent pipe.
- A8. A minimum of 12" straight pipe is recommended from the flue outlet before turns in the vent pipe.
- A9. The vent and combustion air piping must be properly supported with special consideration to the weight of the piping system. The approximate weight per 10 foot sections of Schedule 40 PVC is 14 lbs. for 3" diameter, 20 lbs. for 4" diameter, and 35 lbs. for 6" diameter. Do not use the heater or concentric adapter box to provide support.
- A10. Horizontal sections of vent pipe are to be installed with a minimum upward pitch from the appliance of 1/4 inch per foot and suspended securely from overhead structures at points not greater than 3' apart. Cradle type hangers should be used to allow for expansion and contraction.
- A11. To ensure the piping is leak free after installation, the Schedule 40 PVC vent system, and combustion air inlet piping on applicable model sizes, must be solvent welded (glued) in a manner consistent with normal industry standards and in compliance with all local fire and building code requirements. Primer for joints should conform to ASTM F 656. Cement for joints should conform to ASTM D 2564. For single wall metal combustion air inlet piping (model size 310 only), see note A12 for proper joint sealing.
- A12. For single wall galvanized combustion air inlet piping (model size 310 only), seal joints and seams with silicone sealant or two turns of metallic tape. Fasten individual lengths of vent together with at least three corrosion resistant sheet metal screws.
- A13. Do not install PVC pipe near high temperature sources of heat exceeding 140° F that could damage the pipe and cause hazardous leaks of products of combustion or water into the space.
- A14. Avoid venting through unheated space when possible.

INSTALLATION - VENTING

A15. When the vent passes through a combustible wall or roof, no special clearance to combustible precautions are required to the materials through which the vent passes. Because of the low flue gas temperature, the vent is certified as zero clearance.

A16. Minimum vent termination clearances must be maintained per Table 7.1:

Table 7.1 - Minimum Vent Termination Clearances

Structure	Minimum Clearances for Vent Terminal Location
Forced air inlet within 10 feet	3 feet above
Combustion air inlet of another appliance	6 feet all directions
Door, window, gravity air inlet, or any building opening	4 feet horizontal and below 1 foot above
Electric meter, gas meter, and relief equipment ①	4 feet horizontal (U.S.) 6 feet horizontal (Canada)
Gas regulator ①	3 feet horizontal (U.S.) 6 feet horizontal (Canada)
Adjacent public walkways	7 feet all directions
Grade (ground level)	3 feet above ②

① Do not terminate the vent directly above a gas meter or regulator.

② The vent must be at least 12" higher than anticipated snow depth.

- A17. Do NOT vent this appliance into a masonry chimney.
- A18. Do NOT use dampers or other devices in the vent or combustion air pipes.
- A19. The venting system must be exclusive to a single appliance, and no other appliance is allowed to be vented into it.
- A20. Precautions must be taken to prevent degradation of building materials by flue products.
- A21. To improve the ability to inspect and maintain the vent system, it is recommended that the vent pipe not pass through any unoccupied attic, inside wall, concealed space, or floor.
- A22. Long runs of horizontal or vertical combustion air pipes may require insulation in very cold climates to prevent the buildup of condensation on the outside of the pipe where the pipe passes through conditioned spaces.
- A23. Vertical combustion air pipes should be fitted with a tee with a drip leg and a clean out cap to prevent against the possibility of any moisture in the combustion air pipe from entering the unit. The drip leg should be inspected and cleaned out periodically during the heating season.
- A24. In addition to following these General Instructions, specific instructions for Vertical and Horizontal vent systems in 2-Pipe or Concentric Vent configurations must also be followed. The following outlines the differences:

Vertical Vent System Determination

- Vertical vent systems terminate vertically (up) (an example is shown in Figure 9.1).
- Determine the venting configuration as follows:
 - > For two building penetrations through the roof (one for the combustion air inlet pipe and one for the vent pipe), proceed to "Section B - Vertical Venting".
 - > For a single larger building penetration through the roof, through which both the combustion air inlet and vent pipes will pass, proceed to "Section B - Vertical Venting". Follow those instructions which cover the common requirements for both 2-Pipe and Concentric Vent installations. That section will direct you to "Section D - Horizontal and Vertical Concentric Venting" at the appropriate step of the installation.
 - > For all other cases, proceed to the next section for Horizontal Vent System Determination.

Horizontal Vent System Determination

- Horizontal vent systems terminate horizontally (sideways) (an example is shown in Figure 11.1).
- Determine the venting configuration as follows:
 - > For two building penetrations through the wall (one for the combustion air inlet pipe and one for the vent pipe), proceed to "Section C - Horizontal Venting".
 - > For a single larger building penetration through the wall, through which both the combustion air inlet and vent pipes will pass, proceed to "Section C - Horizontal Venting". Follow those instructions which cover the common requirements for both 2-Pipe and Concentric Vent installations. That section will direct you to "Section D - Horizontal and Vertical Concentric Venting" at the appropriate step of the installation.

INSTALLATION - VENTING

Section B - Vertical Vent System Installation

- B1. This section applies to vertically vented 2-pipe (one combustion air inlet pipe and one vent pipe) and concentric (single roof penetration) vent systems and is in addition to "Section A - General Instructions - All Units".
- B2. Vertical vent systems terminate vertically (up).
- B3. It is required to install a tee with drip leg and clean out cap as shown in Figure 8.1. Please note the following requirements:
- a) Only the vent system drip leg and condensate removal drain connections are shown. Vent and combustion air piping must be terminated per the instructions in this manual, for either 2-pipe or vertical concentric vent arrangements. All venting and drain components, except condensate traps, are by others.
 - b) The standard vent drip leg and drain shown for U.S. ONLY installations utilizes a tee, sized to match the vent diameter for the model size (see Table 6.1). The tee captures and directs the condensate to a cap that is drilled and fitted with a 3/4" fitting for connection to the condensate drain. For installation in Canada, see Note B3c.
 - c) The vent drip leg for Canadian installations must be approved to ULC S636. This requires the use of a series of reducers from the outlet of the tee to the drain connection. Drilling or otherwise modifying the shape or structure of any vent components is not allowed per ULC S636. Note that the 3/4" condensate drain piping and condensate traps are not subject to the ULC S636 requirements that apply to the vent system. This method is also acceptable in US installations.

- d) Connection of a combustion air inlet pipe is required to be connected from the building exterior (not shown in Figure 8.1).
 - e) Condensate drains are required for both the unit heater and the vent system. Properly sized traps are included with the unit. Proper drain design and installation is critical to ensure that the unit and vent systems are properly drained. Refer to the section titled "Condensate Drain and Trap Installation" on page 13 for detailed instructions.
- B4. If a concentric vent system is to pass through one common hole in the roof, please proceed at this point to "Section D - Horizontal and Vertical Concentric Venting" for instructions. Otherwise, proceed to note B5 for instructions on terminating a 2-Pipe installation.
- B5. For 2-pipe vertical configurations, refer to the following instructions and Figure 9.1 with minimum distances as shown.
- B6. The combustion air inlet and vent pipes must each be terminated with two 90° elbows with screened openings (four elbows total). The screens are available from Modine as part of a kit. For model sizes 260 and smaller, the four elbows are to be PVC. For model size 310, the vent pipe is to be terminated with two PVC elbows and the combustion air inlet pipe is to be terminated with two galvanized or other approved corrosion resistant metal elbows.
- B7. The combustion air inlet and vent pipe terminations must be positioned in opposite directions.
- B8. Once venting is complete, proceed to the section titled "Condensate Drain and Trap Installation" on page 13.

Figure 8.1 - Vertical Venting System Drip Leg and Condensate Drain Connections

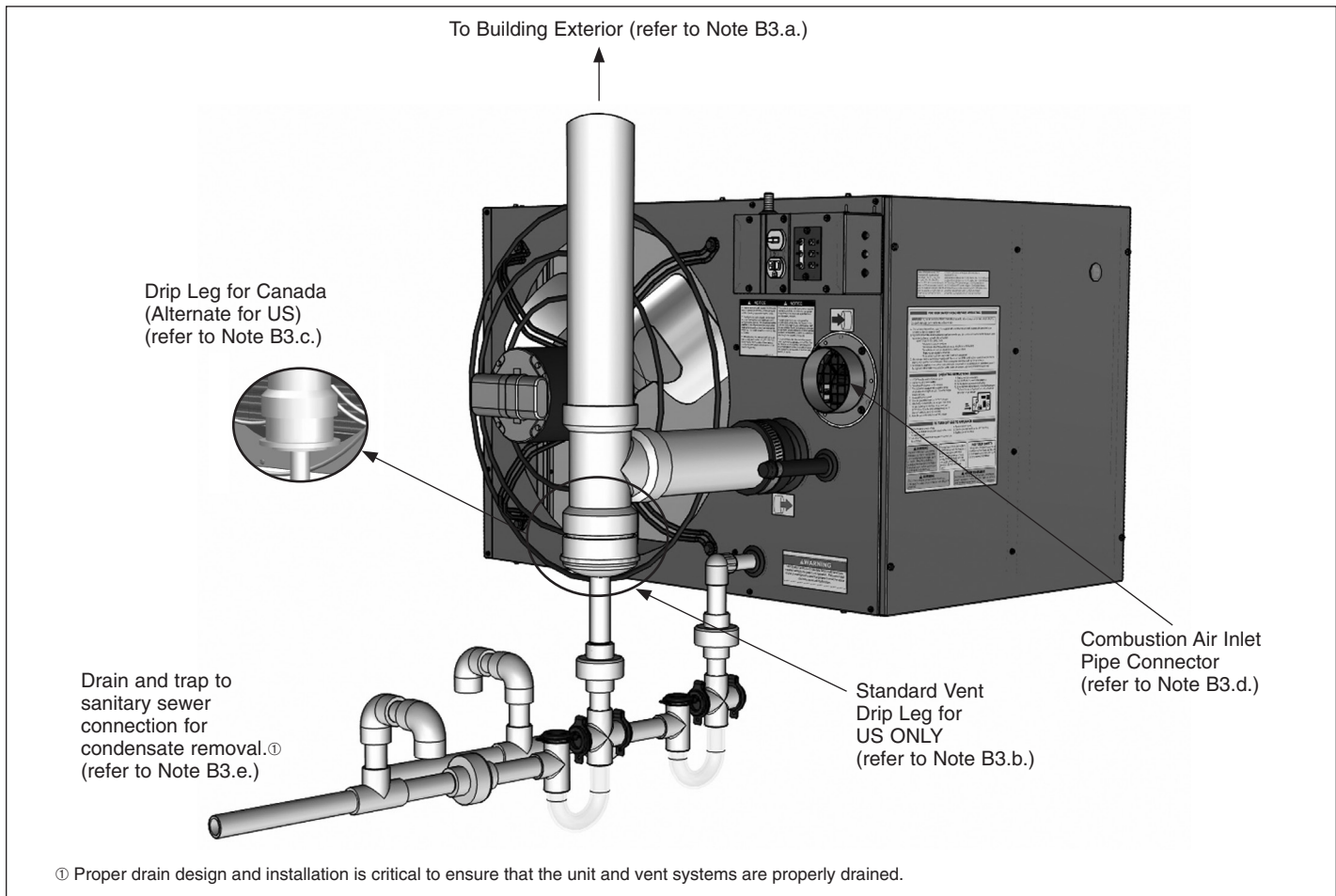

INSTALLATION - VENTING

Figure 9.1 - Vertical 2-Pipe Vent System for Flat Roofs

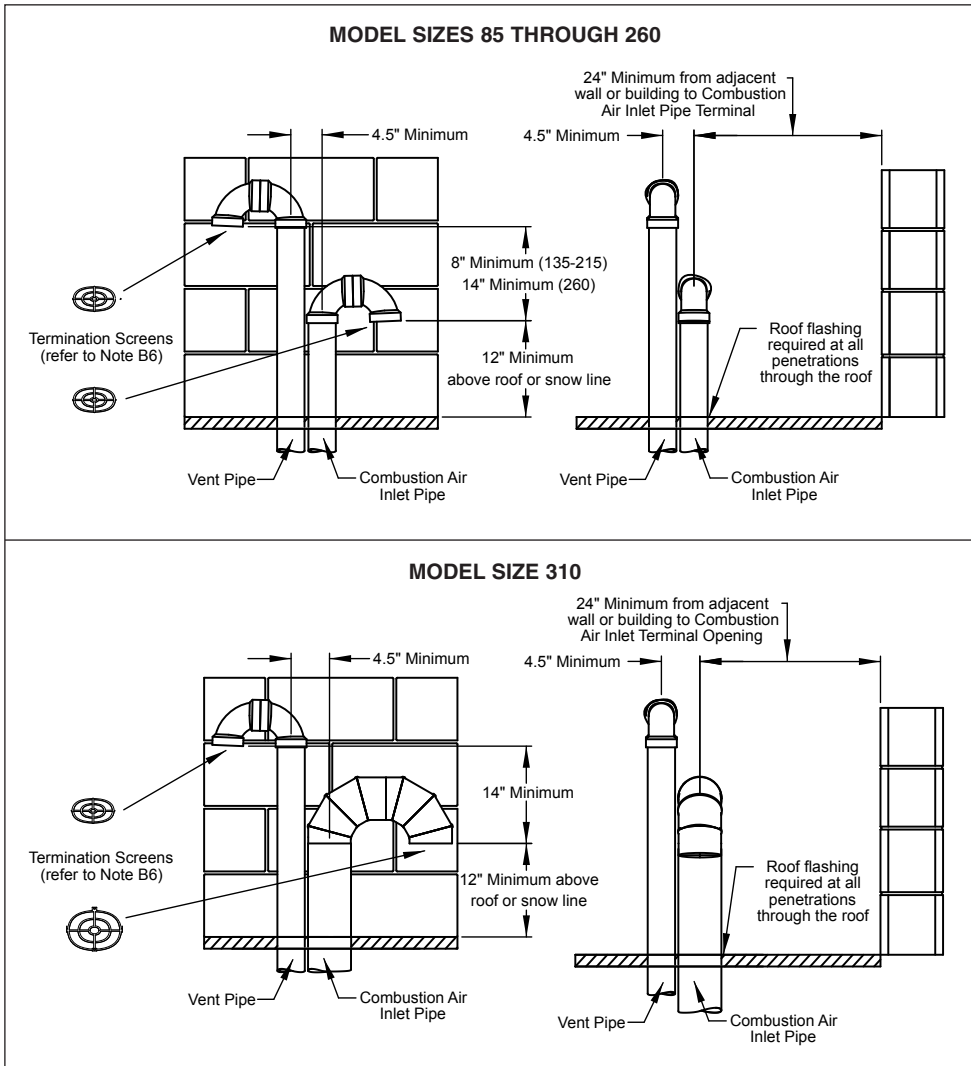
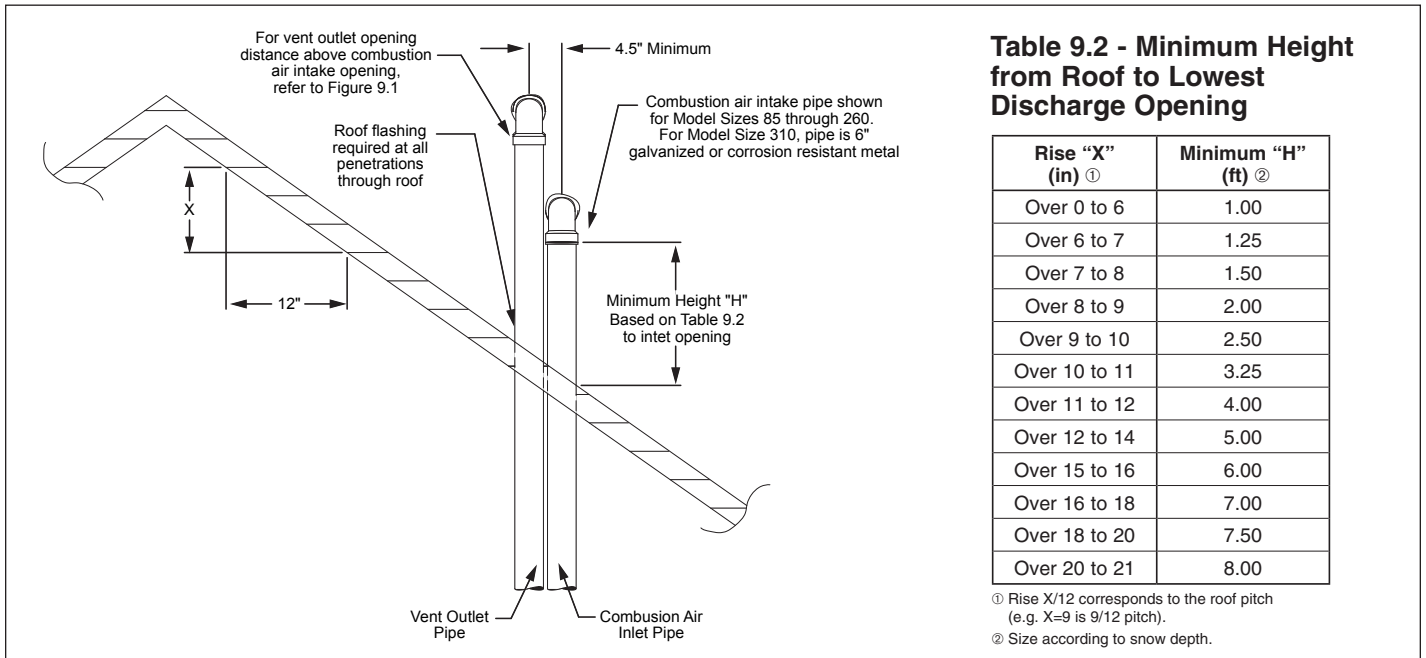

Figure 9.2 - Vertical 2-Pipe Vent System for Sloped Roofs



INSTALLATION - VENTING

Section C - Horizontal Vent System Installation

- C1. This section applies to horizontally vented 2-pipe vent systems (one combustion air inlet pipe and one vent pipe) and concentric (single wall penetration) and is in addition to "Section A - General Instructions - All Units".
- C2. Horizontal vent systems terminate horizontally (sideways).
- C3. It is required to install a tee with drip leg and clean out cap as shown in Figure 10.1. Please note the following requirements:
- a) Only the vent system drip leg and condensate removal drain connections are shown. Vent and combustion air piping must be terminated per the instructions in this manual, for either 2-pipe or horizontal concentric vent arrangements. All venting and drain components, except condensate traps, are by others.
 - b) The standard vent drip leg and drain shown for US ONLY installations utilizes a tee, sized to match the vent diameter for the model size (see Table 6.1). The tee captures and directs the condensate to a cap that is drilled and fitted with a 3/4" fitting for connection to the condensate drain. For installation in Canada, see Note C3c.
 - c) The vent drip leg for Canadian installations must be approved to ULC S636. This requires the use of a series of reducers from the outlet of the tee to the drain connection. Drilling or otherwise modifying the shape or structure of any vent components is not allowed per ULC S636. Note that the 3/4" condensate drain piping and condensate traps are not subject to the ULC S636 requirements that apply to the vent system. This method is also acceptable in US installations.
 - d) Connection of a combustion air inlet pipe is required to be connected from the building exterior (not shown in Figure 10.1)
 - e) A condensate drain each is required from the unit heater and the vent system. Properly sized traps are included with the unit. Proper drain design and installation is critical to ensure that the unit and vent systems are properly drained. Refer to the section titled "Condensate Drain and Trap Installation" on page 13 for detailed instructions.
- C4. If a concentric vent system is to pass through one common hole in the wall, please proceed at this point to "Section D - Horizontal and Vertical Concentric Venting" for instructions. Otherwise, proceed to note C5 for instructions on terminating a 2-Pipe installation.
- C5. For 2-pipe horizontal configurations, refer to the following instructions and Figure 11.1 with minimum distances as shown.
- C6. The vent pipe for all sizes except 260 must be terminated with a PVC 90° elbow with screened opening. The vent pipe for model size 260 must be terminated with a PVC tee with screened openings. These screens are available from Modine as part of a kit.
- C7. For all sizes except 260, the elbow is to be installed on the vent pipe outlet so that the elbow is at a 45° angle with the opening facing away from the combustion air inlet pipe. For model size 260 units, the tee is to be installed horizontally so that the openings of the tee face right and left.
- C8. The combustion air inlet pipe termination is to be a 90° elbow with screened opening. These screens are available from Modine as part of a kit. For model sizes 260 and smaller, the elbow is to be PVC. For model size 310, the elbow is to be galvanized or other approved corrosion resistant metal elbow.
- C9. The elbow is to be installed on the combustion air inlet pipe with the opening of the elbow facing down.
- C10. When condensation may be a problem, the vent system shall not terminate over public walkways or over an area where condensate or vapor could create a nuisance or hazard or could be detrimental to the operation of regulators, relief openings, or other equipment.
- C11. Maintain a 1/4" per foot upward slope away from the heater and place a drip leg with clean out near the vent connector on the heater as shown in Figure 10.1.
- C12. For a vent termination located under an eave, the distance of the overhang must not exceed 24". The clearance to combustibles above the exterior vent must be maintained at a minimum of 12". Consult the National Fuel Gas Code for additional requirements for eaves that have ventilation openings.
- C13. Once venting is complete, proceed section titled "Condensate Drain and Trap Installation" on page 13.

Figure 10.1 - Horizontal Venting System Drip Leg and Condensate Drain Connections

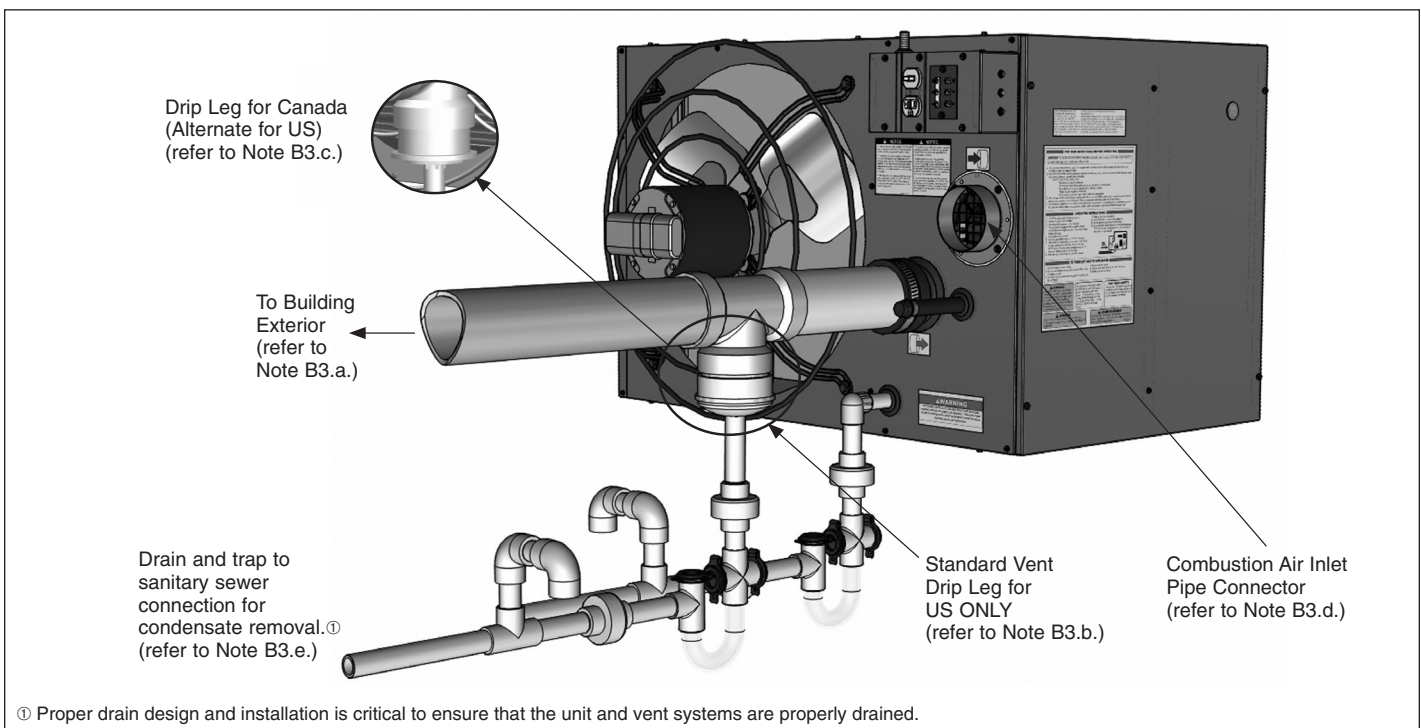

INSTALLATION - VENTING

Figure 11.1 - Horizontal 2-Pipe Vent System

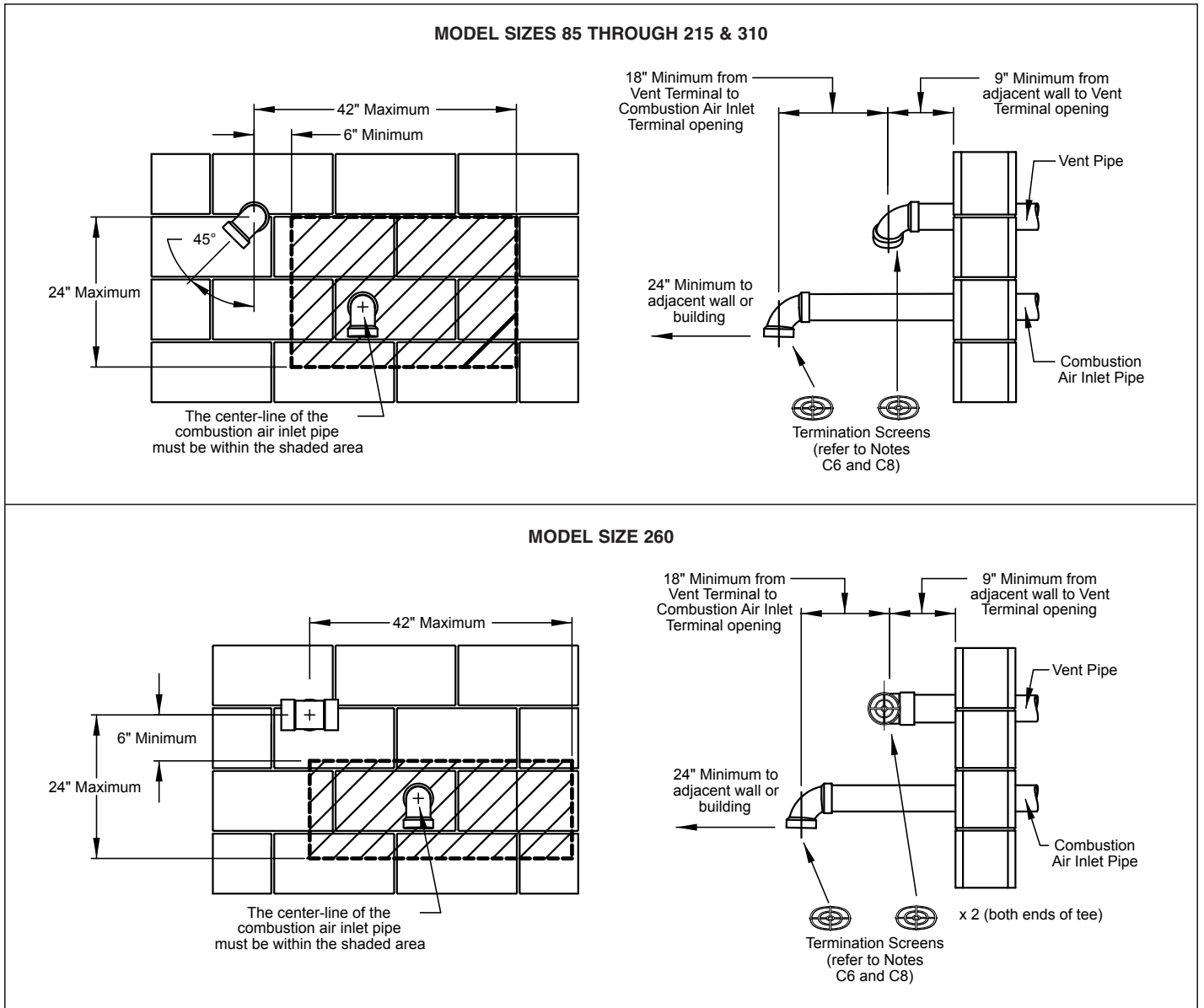

Section D - Concentric Vent System Installation

D1. This section applies to both horizontally and vertically vented concentric vent systems as defined in "Section A - General Instructions - All Units". The required instructions that must be followed are as follows:

For Vertical Concentric Vented Units:

- Section A - General Instructions - All Units
- Section B - Vertical Vent System Installation, steps B1-B4
- Applicable instructions in this section

For Horizontal Concentric Vented Units:

- Section A - General Instructions - All Units
- Section C - Horizontal Vent System Installation, steps C1-C4
- Applicable instructions in this section

D2. When utilizing the concentric vent option, it should have been predetermined whether the appliance will be horizontally or vertically vented. Before proceeding, verify that the concentric vent kit received contains the correct components for the installation:

For Vertically Vented Units (Refer to Figure 12.1):

- ① Concentric Adapter Assembly
- ② Vent Pipe Terminal Screens
- ③ Combustion Air Inlet Pipe Terminal

Figure 12.1 - Vertical Concentric Vent Kit

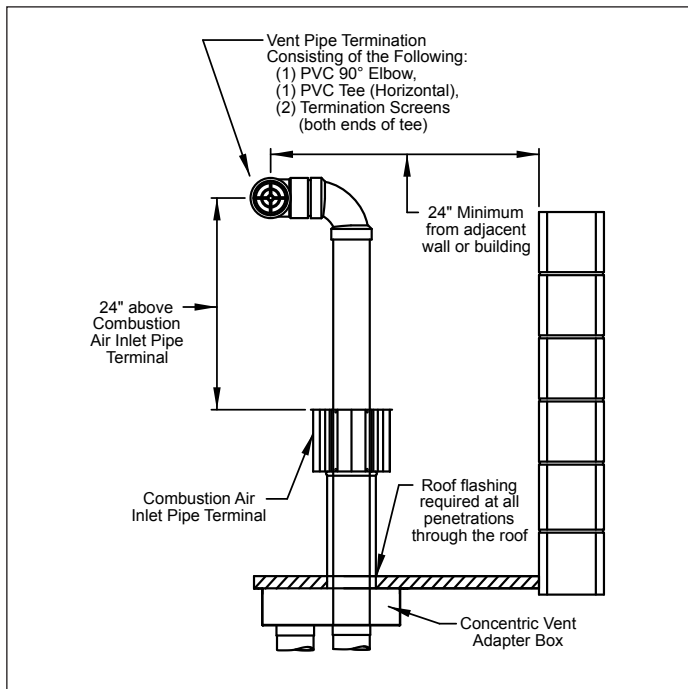

CAUTION

The concentric vent adapter box must be installed inside of the structure or building. Do not install this box on the exterior of a building or structure.

For Horizontally Vented Units (Refer to Figure 12.2):

- ① Concentric Adapter Assembly
- ② Vent Pipe Terminal Screen
- ③ Special Inlet Air Guard

Figure 12.2 - Horizontal Concentric Vent Kit

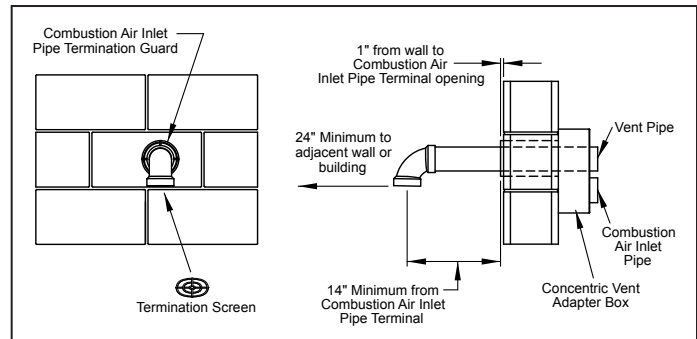

- D3. Once the kit contents have been verified as correct for the direction of venting, the concentric vent adapter box is to be installed. Determine the location of the box. Be sure to maintain all dimensions as listed in these instructions.
- D4. The adapter box is to be mounted on the interior side of the building. It must not be mounted outside the building.
- D5. The adapter box can be mounted flush to the wall (for horizontal kits) or to the ceiling (for vertical kits). When mounting the box, consider serviceability and access to the vent and combustion air pipes.
- D6. Determine the length of the combustion air pipe that must be attached to the combustion air inlet (on the concentric side) of the adapter box to extend through the building wall or roof. Be sure to add the length of the thickness of the wall or roof. Refer to Figures 12.1 or 12.2 to determine the required minimum distance to the termination from the roof or wall.
- D7. Cut the concentric side combustion air pipe to the proper length as determined in the previous step. Refer to Table 6.1 for pipe diameters and material.
- D8. Attach the concentric side combustion air pipe to the air inlet of the concentric adapter box, as shown in Figure 13.1, using at least 3 corrosion resistant sheet metal screws. Seal the joint using caulk.
- D9. Place this assembly (the adapter box and combustion air pipe) through the wall or roof and verify that the distance requirements as defined in Step D6 are met. Securely attach the assembly to the building using the brackets on the adapter box.
- D10. From outside the building, caulk the gap between the combustion air intake pipe and the building penetration.

INSTALLATION - VENTING

Figure 13.1 - Adapter Box with Combustion Air Intake Pipe Attached

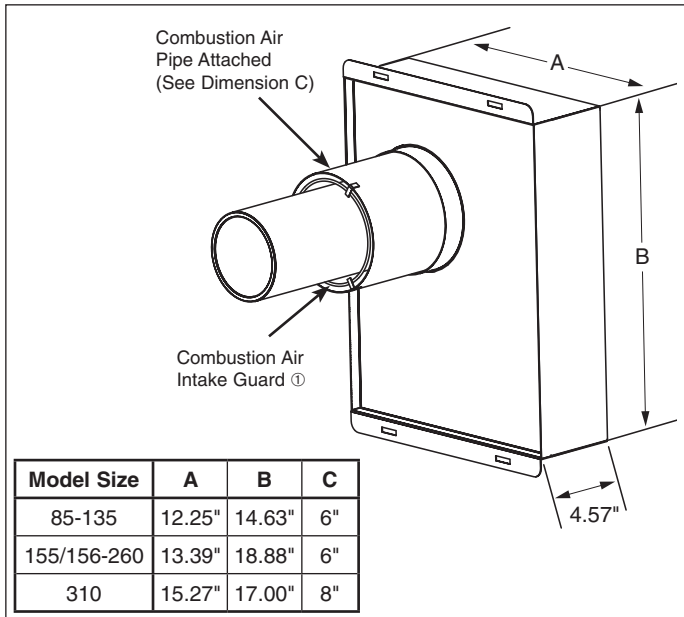

① For reference only for horizontal concentric vent arrangements.

D11. Install the vent pipe by extending the vent pipe all the way through the concentric vent adapter assembly. Seal the adapter around the pipe using caulk.

D12. Attach the combustion air intake and vent pipe terminations as follows:

For Vertical Concentric Vent Kits (refer to Figure 12.1):

- Slide the combustion air cap down over the vent pipe and fasten it to the combustion air pipe with at least 3 corrosion resistant sheet metal screws.
- Terminate the vent pipe with a elbow/tee combination with guards.
- Caulk the gap between the combustion air cap and the vent pipe with silicone sealant or other appropriate caulk.

For Horizontal Concentric Vent Kits (refer to Figure 12.2):

- Attach the combustion air intake guard using corrosion resistant screws at the end of the combustion air intake pipe to prevent animals and debris from entering (see Figure 13.1).
- Solvent weld (glue) the vent termination (elbow or tee) to the vent pipe.
- Install the vent screen(s) in the elbow or tee.

D13. Install the vent and combustion air pipe between unit heater and concentric vent adapter box as outlined in "Section A – General Instructions – All Units".

D14. Once venting is complete, proceed to the following section titled "Condensate Drain and Trap Installation".

Condensate Drain and Trap Installation

During operation, condensate is both produced in the heater and the venting system. The installation requires condensate drain systems from the secondary heat exchanger and from the vent pipe. A condensate trap kit is provided with the unit and consists of two specially designed traps and one PVC elbow for the unit condensate drain connection.

1. For proper heater and vent system performance, the condensate drain system must include a trap for each as shown in Figure 8.1 and Figure 10.1. All joints must be watertight to prevent leakage of condensate.

2. Local code permitting, the condensate drain systems may be joined after the traps and connected to a sanitary drain within the building. Because the condensate produced is acidic, some municipalities may require that the condensate be neutralized before being discharged into the sanitary sewer. A condensate neutralizer tube kit is available from Modine to reduce the pH of the condensate. A separate neutralizer tube is required for both the vent drain and the heater drain, but a single tube can be used for drains that are joined after the traps providing the tube is installed after the junction. Refer to the instructions that come with the kit.
3. Unions are recommended to permit maintenance of the drains and to facilitate service of the heater. A union is shown on both sides of each trap.
4. Connect the threaded side of the PVC elbow supplied to the secondary heat exchanger condensate drain with the socket connection oriented as shown in Figures 8.1 and 10.1.
5. A vacuum breaker is required after each trap as shown in Figures 8.1 and 10.1. The vacuum breaker should be constructed so that dirt and debris do not enter and clog the drain system.
6. For safe operation, the traps should be primed with water. The traps must be installed with the higher side connected to the heater and the lower side connected to the drain.
7. If there is an opportunity that the temperature in the space will fall below freezing during non-operating periods, the condensate drain systems and secondary heat exchanger must be completely drained to prevent freeze damage. Alternately, heat tape can be applied to the drain pipe system in accordance with the heat tape manufacturers instructions.
8. Once the condensate drain lines are complete, proceed to the following section, "Installation - Gas Connections".

Figure 13.2 - Drain Trap

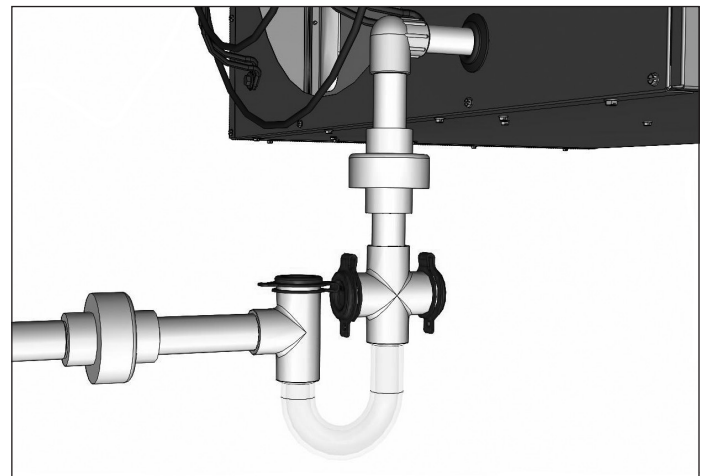
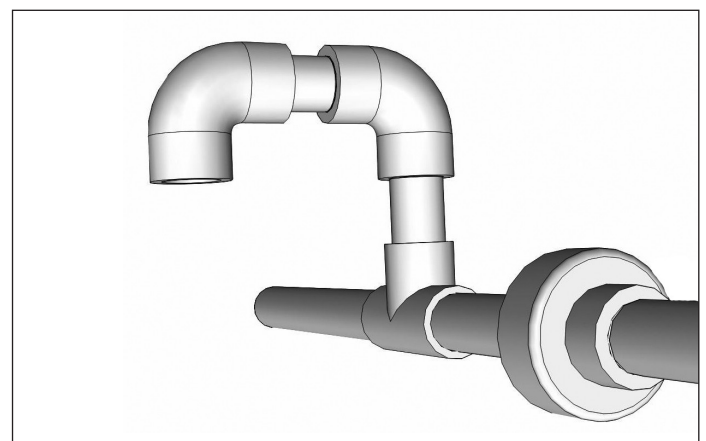

Figure 13.3 - Vacuum Breaker Example



INSTALLATION - GAS CONNECTIONS

GAS CONNECTIONS

⚠ WARNING

1. Installation must conform with local building codes or in the absence of local codes, with the National Fuel Gas Code, ANSI Z223.1 (NFPA 54) - latest edition. In Canada installation must be in accordance with CSA B149.1.
2. All field gas piping must be pressure/leak tested prior to operation. Never use an open flame. Use a soap solution or equivalent for testing.
3. Gas pressure to appliance controls must never exceed 14" W.C. (1/2 psi).
4. To reduce the opportunity for condensation, the minimum sea level input to the appliance, as indicated on the serial plate, must not be less than 5% below the rated input, or 5% below the minimum rated input of dual rated units.

⚠ CAUTION

1. Purging of air from gas lines should be performed as described in the National Fuel Gas Code, ANSI Z223.1 (NFPA 54) - latest edition, or in Canada CSA-B149 codes.
2. When leak testing the gas supply piping system, the appliance and its combination gas control must be isolated during any pressure testing in excess of 14" W.C. (1/2 psi).
3. The unit should be isolated from the gas supply piping system by closing its field installed manual shut-off valve. This manual shut-off valve should be located within 6' of the heater.
4. Turn off all gas before installing appliance.

IMPORTANT

To prevent premature heat exchanger failure, the input to the appliance, as indicated on the serial plate, must not exceed the rated input by more than 5%.

1. Installation of piping must conform with local building codes, or in the absence of local codes, with the National Fuel Gas Code, ANSI Z223.1 (NFPA 54) - latest Edition. In Canada, installation must be in accordance with CSA-B149.1.
2. Piping to units should conform with local and national requirements for type and volume of gas handled, and pressure drop allowed in the line. Refer to Table 14.1 to determine the cubic feet per hour (CFH) for the type of gas and size of unit to be installed. Using this CFH value and the length of pipe necessary, determine the pipe diameter from Table 14.2. Where several units are served by the same main, the total capacity, CFH and length of main must be considered. Avoid pipe sizes smaller than 1/2". Table 14.2 allows for a 0.3" W.C. pressure drop in the supply pressure from the building main to the unit. The inlet pressure to the unit must be 6-7" W.C. for natural gas and 11-14" W.C. for propane gas. When sizing the inlet gas pipe diameter, make sure that the unit supply pressure can be met after the 0.3" W.C. has been subtracted. If the 0.3" W.C. pressure drop is too high, refer to the Gas Engineer's Handbook for other gas pipe capacities.
3. Install a ground joint union with brass seat and a manual shut-off valve adjacent to the unit for emergency shut-off and easy servicing of controls, including a 1/8" NPT plugged tapping accessible for test gauge connection (See Figure 14.1).
4. Provide a sediment trap before each unit in the line where low spots cannot be avoided. (See Figure 14.1).
5. When Pressure/Leak testing, pressures above 11" W.C. (1/2 psi), close the field installed shut-off valve, disconnect the appliance and its combination gas control from the gas supply line, and plug the supply line before testing. When testing pressures 14" W.C. (1/2 psi) or below, close the manual shut-off valve on the appliance before testing.

Figure 14.1 - Recommended Sediment Trap/Manual Shut-off Valve Installation - Side or Bottom Gas Connection ①

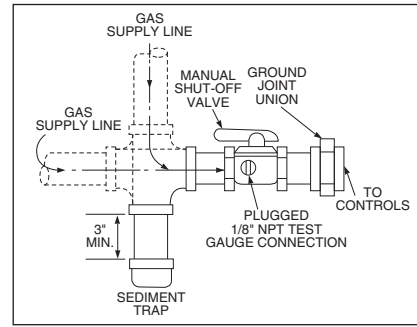

① Manual shut-off valve is in the "OFF" position when handle is perpendicular to pipe.

Table 14.1 - Manifold Pressure & Gas Consumption

Model Size	Manifold Pressure ("W.C.):	Natural	Propane	# of Orifices
		3.5	10	
85	CFH	81.0	34.0	5
	Gal/Hr. Propane	n/a	0.9	
	Orifice Drill Size	47	1.25mm	
110	CFH	105.0	44.0	5
	Gal/Hr. Propane	n/a	1.2	
	Orifice Drill Size	43	54	
135	CFH	128.6	54.0	6
	Gal/Hr. Propane	n/a	1.5	
	Orifice Drill Size	43	54	
155/156	CFH	147.6	62.0	6
	Gal/Hr. Propane	n/a	1.7	
	Orifice Drill Size	41	NA/1.50mm	
180	CFH	171.4	72.0	7
	Gal/Hr. Propane	n/a	2.0	
	Orifice Drill Size	41	53	
215	CFH	204.8	86.0	9
	Gal/Hr. Propane	n/a	2.4	
	Orifice Drill Size	42	54	
260	CFH	247.6	104.0	9
	Gal/Hr. Propane	n/a	2.9	
	Orifice Drill Size	38	52	
310	CFH	295.2	124.0	12
	Gal/Hr. Propane	n/a	3.4	
	Orifice Drill Size	41	53	

Table 14.2 - Gas Pipe Capacities - Natural Gas ① ②

Pipe Length (ft)	Natural Gas					
	1/2"	3/4"	1"	1-1/4"	1-1/2"	2"
10	132	278	520	1050	1600	3050
20	92	190	350	730	1100	2100
30	73	152	285	590	890	1650
40	63	130	245	500	760	1450
50	56	115	215	440	670	1270
60	50	105	195	400	610	1150
70	46	96	180	370	560	1050
80	43	90	170	350	530	930
100	38	79	150	305	460	870
125	34	72	130	275	410	780
150	31	64	120	250	380	710

① Capacities in Cubic Feet per Hour through Schedule 40 pipe with maximum 0.3" W.C. pressure drop with up to 14" W.C. gas pressure. Specific gravity is 0.60 for Natural gas and 1.50 for Propane gas.

② For Pipe Capacity with Propane Gas, divide Natural gas capacity by 1.6. Example: What is the propane gas pipe capacity for 60 feet of 1-1/4" pipe? The Natural gas capacity is 400 CFH. Divide by 1.6 to get 250 CFH for Propane gas.

INSTALLATION - ELECTRICAL CONNECTIONS

ELECTRICAL CONNECTIONS

! WARNING

1. Disconnect power supply before making wiring connections to prevent electrical shock and equipment damage.
2. All appliances must be wired strictly in accordance with wiring diagram furnished with the appliance. Any wiring different from the wiring diagram could result in a hazard to persons and property.
3. Any original factory wiring that requires replacement must be replaced with wiring material having a temperature rating of at least 105°C.
4. Ensure that the supply voltage to the appliance, as indicated on the serial plate, is not 5% greater than or 5% less than the rated voltage.

1. Installation of wiring must conform with local building codes, or in the absence of local codes, with the National Electric Code ANSI/NFPA 70 - Latest Edition. Unit must be electrically grounded in conformance to this code. In Canada, wiring must comply with CSA C22.1, Part 1, Electrical Code.
2. Two copies of the unit wiring diagram are provided with each unit. One is located in the side access control compartment and the other is supplied in the literature packet. Refer to this diagram for all wiring connections.
3. Make sure all multi-voltage components (motors, transformers, etc.) are wired in accordance with the power supply voltage.
4. The power supply to the unit must be protected with a fused or circuit breaker switch.
5. The power supply must be within 5 percent of the voltage rating and each phase must be balanced within 2 percent of each other. If not, advise the utility company.
6. External electrical service connections that must be installed include:
 - a. Supply power connection (115, 208, 230, 460, or 575 volts).
 - b. Connection of thermostats, or any other accessory control devices that may be supplied (24 volts).

NOTE: All units with supply voltage 208V and greater must use a field installed step-down transformer, available as a separate accessory. Refer to Table 15.1 for additional information on the required transformer.

7. Refer to Figure 15.1 for the junction box wiring entry location.

Figure 15.1 - Power/Control Wiring

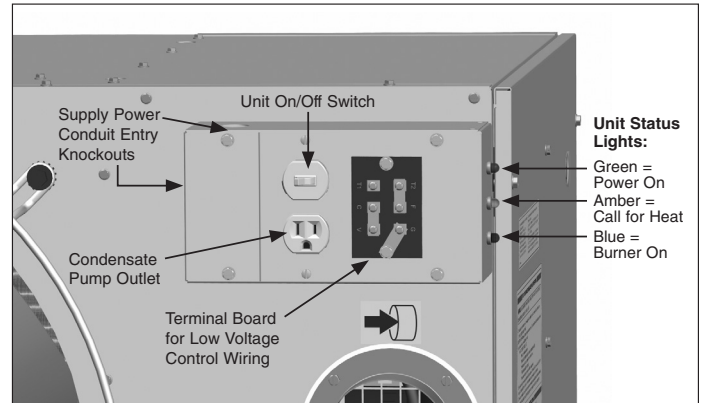

8. All supply power electrical connections are made in the junction box compartment of the unit. The low voltage (thermostat and accessory control devices) can be wired to the terminals on the junction box.

Additional Notes for the Condensate Pump Outlet:

9. The Condensate Pump Outlet supplied with this unit is intended for use with a condensate pump with operating amps not to exceed 2 Amps.
10. The Condensate Pump Outlet can be used as a Service Outlet. To be used as a Service Outlet, the disconnect switch located above the outlet must be in the Off position to disable the unit heater power and gas control circuits to prevent equipment damage. When the unit is wired directly to a 115V power supply, the outlet is rated for a maximum load of 20 amps at 115V. If this unit has been provided with an accessory step-down transformer to 115V from a higher supply voltage, ensure that the load plugged into the outlet does not exceed 8A for 1.0kVA or 12A for 1.5kVA rated transformers.

Table 15.1 - Model PTC Operating Electrical Data ①

Supply Voltage	Power Code		Model PTC Sizes							
			85	110	135	155/156	180	215	260	310
115V 1 Phase	01 (115V)	Motor Amps	2.2	4.6	4.6	4.6	4.6	7.0	8.8	8.8
		Total Amps	4.5	6.9	6.9	6.9	6.9	9.3	11.1	9.9
		Transformer kVA	n/a	n/a	n/a	n/a	n/a	n/a	n/a	n/a
208V 1 or 3 Phase	01 (115V) with Transformer	208V Total Amps	2.49	3.81	3.81	3.81	3.81	5.14	6.14	5.47
		Transformer kVA	1.0	1.0	1.0	1.0	1.0	1.5	1.5	1.5
230V 1 or 3 Phase	01 (115V) with Transformer	230V Total Amps	2.25	3.45	3.45	3.45	3.45	4.65	5.55	4.95
		Transformer kVA	1.0	1.0	1.0	1.0	1.0	1.5	1.5	1.5
460V 3 Phase	01 (115V) with Transformer	460V Total Amps	1.13	1.73	1.73	1.73	1.73	2.33	2.78	2.48
		Transformer kVA	1.0	1.0	1.0	1.0	1.0	1.5	1.5	1.5
575V 3 Phase	01 (115V) with Transformer	575V Total Amps	0.9	1.38	1.38	1.38	1.38	1.86	2.22	1.98
		Transformer kVA	1.0	1.0	1.0	1.0	1.0	1.5	1.5	1.5

① Amp draw data shown is operating amp draw at incoming power. For units that use a field installed accessory step-down transformer as noted, the amp draw shown is the primary side operating amp draw. For sizing of circuit protection for equipment with transformers, please refer to the National Electric Code.

INSTALLATION - OPERATION

OPERATION

Prior to Operation

IMPORTANT

1. Start-up and adjustment procedures should be performed by a qualified service agency.

Although this unit has been assembled and fire-tested at the factory, the following pre-operational procedures should be performed to assure proper on-site operation.

1. Turn off power to the unit at the disconnect switch. Check that fuses or circuit breakers are in place and sized correctly. Turn all hand gas valves to the "OFF" position.
2. Remove the side control access panel.
3. Check that the supply voltage matches the unit supply voltage listed on the Model Identification plate. Verify that all wiring is secure and properly protected. Trace circuits to insure that the unit has been wired according to the wiring diagram.
4. Check to see that there are no obstructions to the intake and discharge of the unit.
5. Check fan clearance. Fan should not contact casing when spun by hand.
6. Perform a visual inspection of the unit to make sure no damage has occurred during installation.
7. Turn on power to the unit at the disconnect switch. Verify that the Green light on the unit junction box is on, which confirms power is on.
8. With the gas turned off, check the thermostat, ignition control, gas valve, and supply fan motor for electrical operation by creating a call for heat from the thermostat. If these do not function, recheck the wiring diagram. Verify that the Amber light on the unit junction box is on, confirming that there is a call for heat.
9. Check the motor speed (rpm).
10. Check the motor voltage.
11. Check the motor amp draw to make sure it does not exceed the motor nameplate rating.
12. Recheck the gas supply pressure at the field installed manual shut-off valve. The minimum inlet pressure should be 6" W.C. on natural gas and 11" W.C. on propane gas. The maximum inlet pressure for either gas is 14" W.C. If inlet pressure exceeds 14" W.C., a gas pressure regulator must be added upstream of the combination gas valve.
13. Open the field installed manual gas shut-off valve.
14. Place the manual main gas valve on the combination gas valve in the "On" position. Call for heat with the thermostat.
15. Check to make sure that the main gas valve opens. Check the manifold gas pressure (See Main Gas Adjustment) while the supply fan is operating. Verify that the Blue light on the unit junction box is on, confirming that the main gas valve is open.
16. Check to insure that gas controls sequence properly (See Control Operating Sequence). If you are not familiar with the unit's controls (i.e. combination gas control), refer to the control manufacturer's literature supplied with the unit.

17. Check to insure that the venting system is installed correctly and is free from obstructions. Before you start use the following steps to verify that the venting system is adequately sized:
 - a. Inspect the venting system for proper size and horizontal pitch, as required in these instructions. Determine that there is no blockage or restriction, leakage, and other deficiencies, which could cause an unsafe condition.
 - b. Follow the lighting instructions. Place the appliance being inspected in operation. Adjust thermostat so that the appliance will operate continuously.
 - c. If the vent pressure switch does not close during any of the above tests, the venting system must be corrected.
18. Once proper operation of the unit has been verified, remove any jumper wires that were required for testing.
19. Replace the side control access panel.

Main Gas Adjustment

The gas pressure regulator (integral to the combination gas control) is adjusted at the factory for average gas conditions. It is important that gas be supplied to the unit heater in accordance with the input rating on the serial plate. Actual input should be checked and necessary adjustments made after the unit heater is installed. Over-firing, a result of too high an input, reduces the life of the appliance and increases maintenance. Under no circumstances should the input exceed that shown on the serial plate.

Measuring the manifold pressure is done at the outlet pressure tap of the gas valve.

To Adjust the Manifold Pressure

1. Move the field installed manual shut-off valve to the "OFF" position.
2. Remove the 1/8" pipe plug from the outlet pressure tap on the gas valve and attach a water manometer of "U" tube type which is at least 12" high.
3. Move the field installed manual gas shut-off valve to the "ON" position.
4. Create a call for heat from the thermostat.
5. Refer to Table 14.1 to determine the correct manifold pressure for the gas type of the unit. Adjust the main gas pressure regulator spring to achieve the proper manifold pressure (for location, see the combination gas control literature supplied with unit).
6. After adjustment, move the field installed manual shut-off valve to the "OFF" position and replace the 1/8" pipe plug.
7. After the plug is in place, move the field installed manual shut-off valve to the "ON" position and recheck pipe plugs for gas leaks with soap solution.

CONTROL OPERATING SEQUENCE

Upon a call for heat from the thermostat, power is supplied to the power exhaustor motor. The unit will go through a purge period and then the direct spark igniter will be energized. At the same time, the main valve in the combination control valve will open to allow gas to flow to the burners. If the fan motor has not already started it will start shortly. If a flame is not sensed within 7 seconds for any reason the main valve will close and there will be a short purge period before ignition is tried again. If the flame is not sensed after four tries there will be at least a one hour wait before ignition is tried again.

UNIT COMPONENTS

Control Options

Control Description	Control Code No.	Service Voltage	Thermostat Voltage	Type of Gas
Single-Stage, Direct Spark Ignition, 100% Shut-Off with Continuous Retry Utilizes a single-stage combination gas control with ignition control. Gas is lit with a direct spark igniter on call for heat.	11	115V	24V	natural
	21	115V	24V	propane

Figure 17.1 - Factory Mounted Standard Features

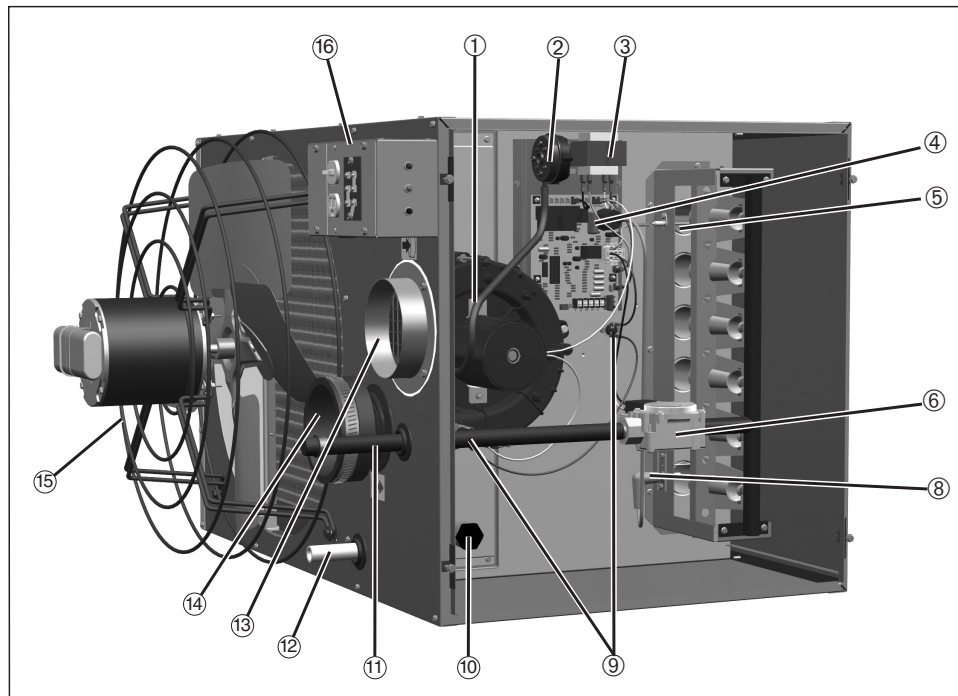

- ⑥ **Single Stage Gas Valve**
The main gas valve is factory installed on the unit heater gas train. The main gas valve provides regulator, main gas, and manual shutoff functions. The valve is redundant and provides 100% shut off. Natural gas is Control Code 11, propane gas is Control Code 21.
- ⑦ **Flame Roll Out Switch (size 110 and smaller only) (hidden)**
Flame roll out switches are mounted near the burners and will shut off the gas supply in the event of an unsafe flame roll out condition.
- ⑧ **Direct Spark Igniter**
Provides spark for direct ignition of the burners.
- ⑨ **High Limit Switches**
One limit control is mounted in the air stream and will shut off the gas supply in the event of overheating. The other limit control is mounted on the power exhauster housing and will shut off the gas supply in the event of overheating flue gas temperatures.

- ① **Power Exhauster**
All units are supplied with a round vent pipe and combustion air inlet pipe connections.
- ② **Pressure Switch**
An automatic reset vent pressure switch is supplied on all units and is designed to prevent operation of the main burner in the event there is restricted venting of flue products. This restriction may occur due to an improper vent diameter, long vent runs, un-approved vent terminal, high winds, high negative pressure within space, etc. After the cause of the restriction has been corrected, the pressure switch will reset automatically.
- ③ **Control Step Down Transformer**
The control step down transformer is located in the electrical junction box. The transformer is used to step the voltage down from 115V to 24V for the gas controls, fan delay relay, field supplied motor starter, etc. An additional field installed transformer is required if the supply voltage is 208V, 230V, 460V, or 575V. To determine the control transformer supplied as well as any required accessory transformers, refer to Table 15.1.
- ④ **Integrated Direct Spark Control Board**
The integrated direct spark ignition control combines all furnace control functions. The integrated board provides digital control of the air mover, inducer, ignition, gas valve and flame sensing as well as monitoring the safety circuit at all times. The board includes LED diagnostics for trouble shooting and a fused power supply. Ignition control is 100% shut-off with continuous retry.
- ⑤ **Flame Sensor**
Remote flame sensor verifies ignition of all burners, monitors the flame signal and communicates with the integrated circuit board.
- ⑩ **Condensate Drain Overflow Switch**
Shuts down gas controls if condensate is not properly draining from the unit.
- ⑪ **Gas Pipe Connection**
Easy access to factory installed gas pipe connection stubbed to outside of unit casing.
- ⑫ **Condensate Drain Connection**
Easy access to factory installed condensate drain pipe connection stubbed to outside of unit casing.
- ⑬ **Combustion Air Inlet Pipe Connection**
Simple connection for combustion air inlet piping.
- ⑭ **Vent Pipe Connection**
Rubber exhaust coupling with clamp for easy connection of PVC vent system.
- ⑮ **Fan Guard**
Propeller units may be equipped with an optional (standard on size 110 and smaller) finger proof fan guard for added protection. If ordered, the finger proof fan guard is installed at the factory in place of the standard fan guard.
- ⑯ **Contractor Convenience Package**
External junction box features simple connection of supply power wiring internally, thermostat wiring to terminals externally, an On/Off switch, a single 115V outlet for connection of an external condensate pump, and status indicator lights to display the operational state of the unit.
- ⑰ **Horizontal Air Deflector Blades (not shown in Figure 17.1)**
Factory mounted on the discharge of the unit, the blades can be adjusted to provide horizontal (up and down) delivery control of the heated air. Vertical deflector blades are available as a field installed accessory.

GENERAL PERFORMANCE DATA - MODELS PTC

Table 18.1 - Propeller Unit Heater Model PTC General Performance Data

	Model PTC Sizes							
	85	110	135	155/156	180	215	260	310
Btu/Hr Input ①	85,000	110,000	135,000	155,000	180,000	215,000	260,000	310,000
Btu/Hr Output ①	79,050	102,300	125,500	144,150	167,400	199,950	241,800	288,300
Condensate Production (Gal./Hr.)	0.5	0.7	1.0	1.1	1.3	1.6	1.9	2.3
Entering Airflow (CFM) @ 70°F ②	1650	1750	2160	2510/2600	3020	3865	4585	5400
Outlet Velocity (FPM) ②	619	668	719	835/862	676	699	831	765
Air Temp. Rise (°F)	44	54	54	53/51	51	48	49	49
Max. Mounting Height (Ft.) ②	13	13	14	17/18	15	17	20	19
Heat Throw (Ft.) @ Max. Mtg Ht	48	46	51	59/62	53	60	70	67
Motor Type ③	PSC	PSC	PSC	PSC	PSC	PSC	PSC	PSC
Motor HP	1/8	1/3	1/3	1/3	1/3	1/2	3/4	3/4
Motor RPM	1550	1075	1075	1075	1075	1075	1125	1125

① Ratings shown are for elevations up to 2,000 ft. For elevations above 2,000 feet, ratings should be reduced at the rate of 4% for each 1,000 feet above sea level. (In Canada see rating plate.) Reduction of ratings requires use of a high altitude kit.

② Data taken at 65°F ambient and unit fired at full-rated input. Mounting height as measured from bottom of unit, and without deflector hoods.

③ All motors used are produced, rated and tested by reputable manufacturers in accordance with NEMA standards and carry the standard warranty of both the motor manufacturer and Modine. All motors are totally enclosed and all single phase motors have built-in thermal overload protection.

Figure 18.1 - 30°, 60°, & 90° Deflector Hoods

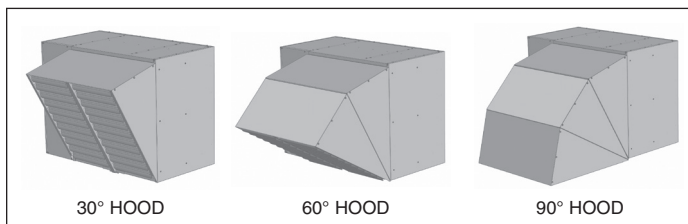

Figure 18.2 - 30° & 60° Hood Throw/Floor Coverage

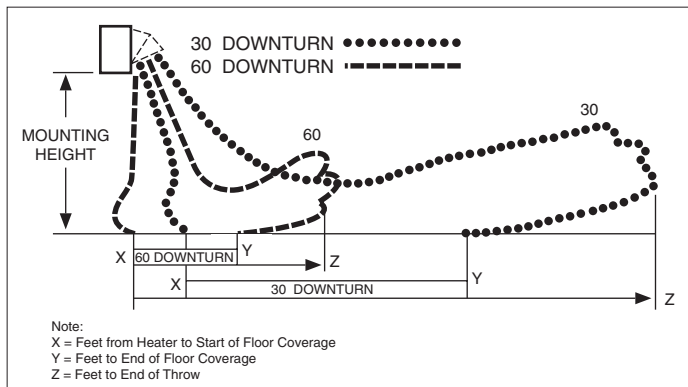

Figure 18.3 - 90° Hood Throw/Floor Coverage

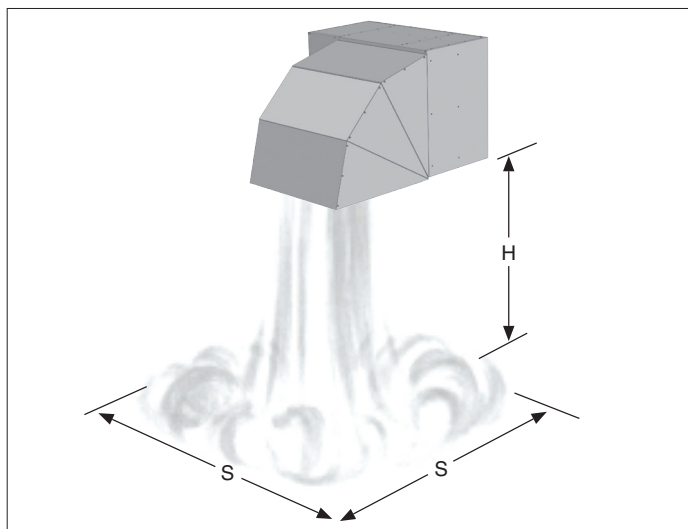

Table 18.2 - Deflector Hood Performance Data

Model Size	Airflow (CFM)	Temp Rise (°F)	Mounting Height (ft)	Blade Angle (°)	30° Hood			60° Hood			90° Hood
					X	Y	Z	X	Y	Z	S
					(ft)	(ft)	(ft)	(ft)	(ft)	(ft)	(ft)
85	1650	44	8	59	14	30	41	0	32	43	17
			10	49	12	29	39	0	29	40	16
			12	39	11	26	37	0	26	36	14
			13	32	10	25	35	0	24	33	14
110	1750	54	8	57	13	29	39	0	30	41	16
			10	47	11	27	37	0	28	38	15
			12	35	10	25	34	0	24	33	13
			13	28	9	23	32	0	22	30	13
135	2160	53	8	60	15	32	44	0	34	47	24
			10	52	13	31	42	0	32	44	21
			12	42	12	29	40	0	29	40	19
			14	30	10	26	36	0	25	34	18
155	2510	53	8	60	14	32	43	0	33	46	23
			10	51	13	30	42	0	31	43	21
			12	41	12	28	39	0	28	39	19
			14	29	10	25	35	0	24	33	17
156	2600	51	8	60	19	41	56	0	43	60	26
			10	51	18	40	55	0	42	57	23
			12	41	17	38	53	0	40	55	21
			14	29	15	37	51	0	37	51	20
180	3020	51	8	63	16	35	48	0	37	51	26
			10	55	15	34	46	0	35	48	23
			12	46	13	32	44	0	32	45	21
			14	36	12	29	41	0	29	40	20
215	3865	48	8	66	19	41	56	0	43	59	32
			10	60	18	40	54	0	42	57	29
			12	53	17	38	53	0	40	54	26
			14	46	15	36	50	0	37	51	24
260	4585	49	8	69	22	45	62	0	48	66	37
			10	63	21	44	61	0	47	64	33
			12	57	19	43	59	0	45	62	30
			14	51	18	42	57	0	43	59	28
310	5400	49	8	68	20	43	58	0	45	62	34
			10	61	19	42	57	0	44	60	31
			12	55	18	40	55	0	42	58	28
			14	48	17	39	53	0	40	54	26
310	5400	49	16	40	15	37	51	0	36	50	24
			18	31	13	34	47	0	32	44	23

Note: Refer to Figures 18.1 and 18.2

DIMENSIONAL DATA - MODEL PTC

Figure 19.1 - Dimensional Drawings - Model PTC

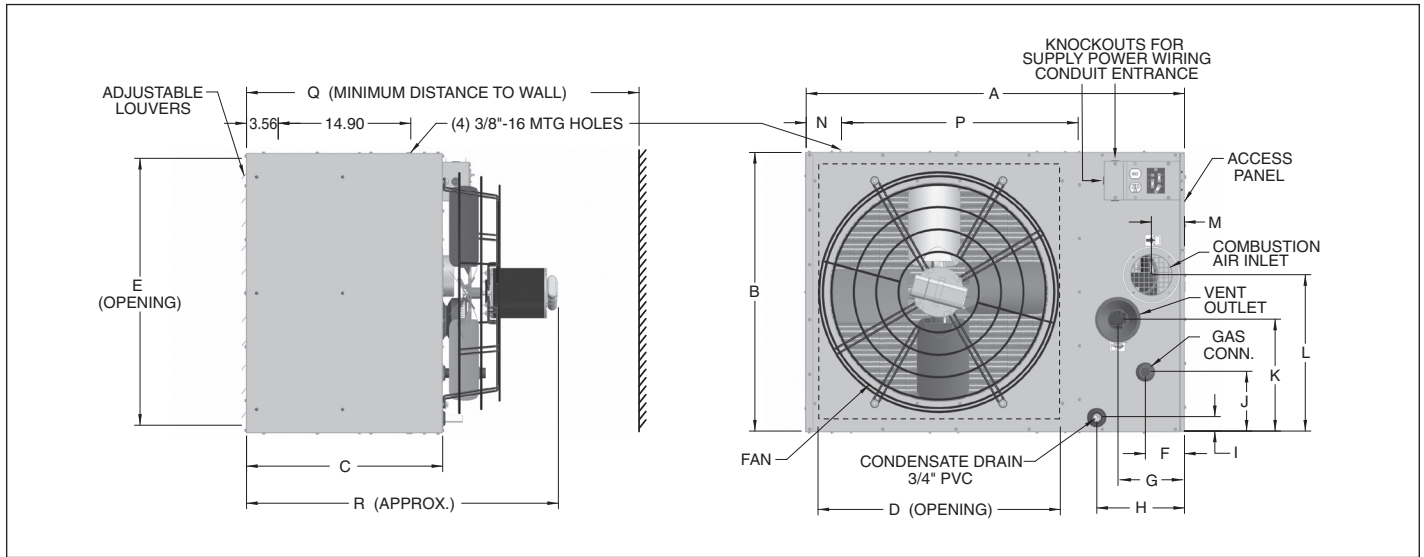

Table 19.1 - Dimensions (inches)

Models	PTC 85	PTC110	PTC135	PTC155/156	PTC180	PTC 215	PTC260	PTC310
A	35.53	35.53	35.53	35.53	42.53	42.53	42.53	42.53
B	20.31	20.31	23.06	23.06	25.81	31.31	31.31	39.56
C	22.05	22.05	22.05	22.05	22.05	22.05	22.05	22.05
D	22.52	22.52	22.52	22.52	29.52	29.52	29.52	29.52
E	18.42	18.42	21.18	21.18	23.93	29.43	29.43	37.68
F	4.50	4.50	4.50	4.50	4.50	4.50	4.50	4.50
G	7.98	7.98	7.98	7.98	7.98	7.47	7.47	8.12
H	10.27	10.27	10.18	10.18	10.36	9.86	9.86	9.79
I	1.32	1.32	2.15	2.15	1.73	1.63	1.63	1.88
J	6.73	6.73	8.09	8.09	9.47	6.72	6.72	10.84
K	8.74	8.74	8.45	8.45	9.82	12.58	12.58	16.19
L	12.13	12.13	12.95	13.45	14.92	17.58	17.58	22.19
M	3.86	3.86	3.48	3.98	3.98	3.72	3.72	4.62
N	1.54	1.54	1.54	1.54	3.97	3.97	3.97	3.97
P	22.03	22.03	22.03	22.03	26.60	26.60	26.60	26.60
Q	45.83	45.83	45.83	45.83	45.83	45.83	46.83	46.83
R	33.83	33.83	33.83	33.83	33.83	33.83	34.83	34.83
Combustion Air Inlet Pipe	3	3	3	4	4	4	4	6
Vent Outlet Pipe	3	3	3	4	4	4	4	4
Gas Connection	1/2	1/2	1/2	1/2	1/2	3/4	3/4	3/4
Fan Diameter	18	18	20	20	22	24	24	26
Approx. Shipping Weight (lbs.)	125	128	165	165	215	265	265	310

SERVICE / MAINTENANCE / TROUBLESHOOTING

WARNING

When servicing or repairing this equipment, use only factory-approved service replacement parts. A complete replacement parts list may be obtained by contacting the factory. Refer to the rating plate on the appliance for complete appliance model number, serial number, and company address. Any substitution of parts or controls not approved by the factory will be at the owner's risk.

CAUTION

1. Service or repair of this equipment must be performed by a qualified service agency.
2. Do not attempt to reuse any mechanical or electrical controllers which have been wet. Replace defective controller.

IMPORTANT

To check most of the Possible Remedies in the troubleshooting guide listed in Table 21.1, refer to the applicable sections of the manual.

General Maintenance

The unit and venting system must be checked once a year by a qualified service technician.

All installation and service of these units must be performed by a qualified installation and service agency.

Before any service, BE SURE TO TURN OFF GAS AT THE MANUAL SHUT-OFF VALVE AHEAD OF THE COMBINATION GAS CONTROL AND TURN OFF ALL ELECTRIC POWER TO THE HEATER.

1. Service air moving components annually.
 - a. Check fan for fit on motor shaft and for damage to blades.
2. Keep unit free from dust, dirt, grease, and foreign matter, paying particular attention to:
 - a. Combustion air inlets.
 - b. Burners and burner orifices. Open the union on the gas line, and disconnect the igniter and sensor wires. Remove the screws that attach the burner tray to the header plate and remove the burner tray and manifold assembly from the heater. Carefully clean the burners with a wire brush or other suitable means. Replace any damaged or deteriorating burners or orifices. Verify that the burners are touching each other at the carryover points. This will ensure flame carryover from burner to burner. Install the burner assembly back on to the header making certain that all screws, pipes and electrical connections are tight.
 - c. Clean exterior of heat exchanger tubes. For cleaning the fins on the secondary heat exchanger, either use a soft brush and vacuum cleaner or use a compressed air hose through the discharge opening of the unit (the opening with the louvers) to blow the debris out of the fins.
 - d. Fan blades.
3. Inspect the flame sensor and igniter for deterioration and/or cracks.

CAUTION: Be careful when handling the igniter and flame sensor.
4. Check wiring for possible loose connections.
5. The gas valves and piping should be checked annually for general cleanliness and tightness. The gas controls should be checked to insure that the unit is operating properly. See control instruction sheets furnished separately with the unit heater.
6. The power exhaust motor bearings have been lubricated for long life and do not require additional lubrication. In dirty atmospheres, it may be desirable to clean the motors and blower housing and blow out the cooling air passages of the motor with compressed air.
7. Perform periodic cleaning of inlet and vent terminal screens.
8. Clean the condensate drain traps and refill with water.
9. If a condensate pump is being used with overhead condensate drain lines, inspect the pump for proper operation and maintain per the pump manufacturer's instructions. Replace the condensate pump treatment tablets if equipped.
10. If a condensate neutralizer tube is installed, recharge per the neutralizer tube manufacturer's instructions.
11. Check the condensate overflow switch for cleanliness and proper operation.

SERVICE / MAINTENANCE / TROUBLESHOOTING

Table 21.1 - Troubleshooting

TROUBLE	POSSIBLE CAUSE	POSSIBLE REMEDY
Unit does nothing (verify Green light on side of junction box is lit)	<ol style="list-style-type: none"> 1. Power supply is off 2. No 24V power to thermostat 3. Thermostat malfunction 4. LED flashes 5. Defective control 	<ol style="list-style-type: none"> 1. Turn on main power 2 a. Check control transformer <ol style="list-style-type: none"> b. If failed transformer - check thermostat wire gage and length 3 a. Verify wire connections to R&W terminals only <ol style="list-style-type: none"> b. Check / replace thermostat 4. Check LED flash code 5. Replace control
LED light on ignition controller in main control compartment off or flashing	<ol style="list-style-type: none"> 1. Multiple causes 	<ol style="list-style-type: none"> 1. Control board LED flash codes vary with control type. A decal is installed in the unit giving a brief description of the applicable codes for your heater. For more detail, see the control board data sheet included with this manual.
Unit starts but does not ignite (verify Green and Amber lights on side of junction box are lit)	<ol style="list-style-type: none"> 1. Main gas is off 2. Air in gas line 3. Main or manifold gas pressure 4. Check gas valve switch 5. Clogged condensate drain line 6. Tripped limit switch on Power Exhauster 	<ol style="list-style-type: none"> 1. Open manual gas valve 2. Purge gas line 3. Set gas pressures per manual instructions 4. Set gas valve switch to "ON" position 5. Check condensate drain line, clean as required 6. Inspect and reset limit switch if no unit damage found
Unit goes through cycle, but the burners go out in less than 10 seconds	<ol style="list-style-type: none"> 1. Reversed main power polarity 2. Unit not grounded 3. Flame not sensed 	<ol style="list-style-type: none"> 1. Black wire - HOT, White wire - NEUTRAL, Green wire - Ground 2. Ground unit and verify quality of ground connection 3. Check flame sensing probe and connection
Air circulating fan inoperable	<ol style="list-style-type: none"> 1. Loose connections 2. Defective control board 3. Defective fan motor 	<ol style="list-style-type: none"> 1. Check all connections 2. Check control board data sheet and function 3. Check fan motor

PAGE INTENTIONALLY LEFT BLANK

SERIAL & MODEL NUMBER / REPLACEMENT PARTS

Serial Number Designations (Remove access cover to locate)

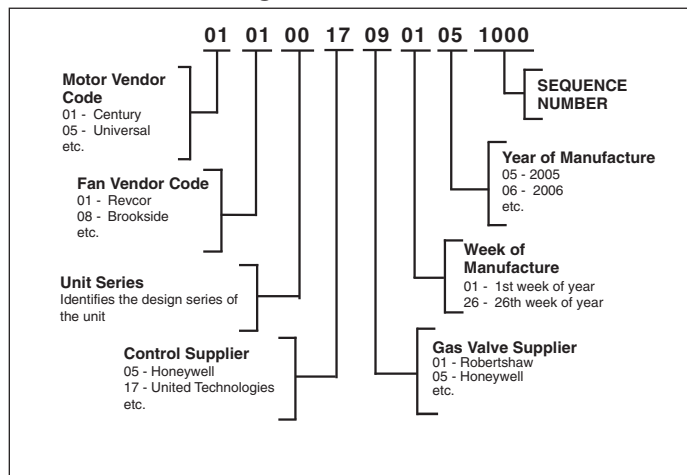

Model Number Designations (Remove access cover to locate)

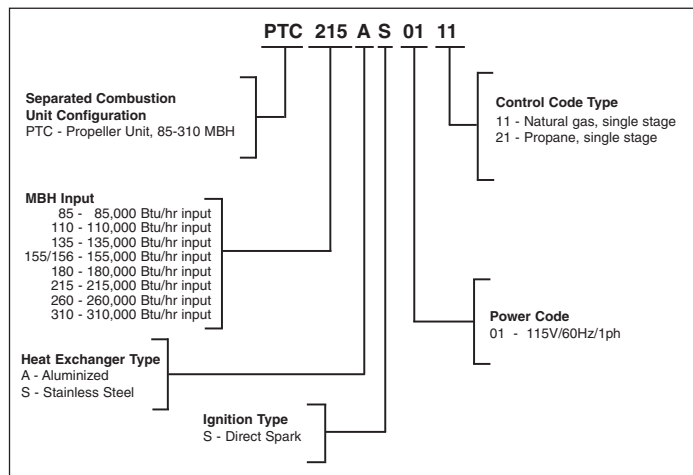

Replacement Parts

When requesting parts please contact your local representative. Please have full model and serial number available. If you require assistance in locating your representative, please call the number located on the back page.

Table 23.1 Common Replacement Parts (The list is subject to change. Please refer to unit mounted parts list for most up-to-date list.)

Model Size	Power Exhauster	Limit Control Switch			Pressure Switch	Igniter	Ignition Control	Combination Gas Valve	
		Heat Exchanger Header	Power Exhauster	Flame Rollout				Control Code 11	Control Code 21
PTC 85	5H080704	5H073593A	5H080746A1	5H075002A5	5H079441B8	5H079636	5H079749B1700	5H079751	5H079869
PTC110	5H080704	5H073593A	5H080746A1	5H075002A7	5H079441B7	5H079636	5H079749B1700	5H079751	5H079869
PTC135	5H080704	5H074976A7	5H080746A1	NA	5H079441B2	5H079636	5H079749B1700	5H079751	5H079869
PTC155	5H080704	5H074976A7	5H080746A1	NA	5H079441B9	5H079636	5H079749B1700	5H079751	5H079869
PTC156	5H080704	5H074976A7	5H080746A1	NA	5H079441B7	5H079636	5H079749B1700	5H079751	5H079869
PTC180	5H080704	5H073593B	5H080746A1	NA	5H079441B7	5H079636	5H079749B1700	5H079751	5H079869
PTC215	5H080704	5H073593B	5H080746A1	NA	5H079441B13	5H079636	5H079749B1700	5H079750	5H079870
PTC260	5H080704	5H075769B3	5H080746A1	NA	5H079441B2	5H079636	5H079749B1700	5H079750	5H079870
PTC310	5H080749	5H073593B	5H080746A1	NA	5H079441B10	5H079636	5H079749B1700	5H079750	5H079870

COMMERCIAL WARRANTY

Seller warrants its products to be free from defects in material and workmanship, EXCLUSIVE, HOWEVER, of failures attributable to the use of materials substituted under emergency conditions for materials normally employed. This warranty covers replacement of any parts furnished from the factory of Seller, but does not cover labor of any kind and materials not furnished by Seller, or any charges for any such labor or materials, whether such labor, materials or charges thereon are due to replacement of parts, adjustments, repairs, or any other work done. This warranty does not apply to any equipment which shall have been repaired or altered outside the factory of Seller in any way so as, in the judgment of Seller, to affect its stability, nor which has been subjected to misuse, negligence, or operating conditions in excess of those for which such equipment was designed. This warranty does not cover the effects of physical or chemical properties of water or steam or other liquids or gases used in the equipment.

BUYER AGREES THAT SELLER'S WARRANTY OF ITS PRODUCTS TO BE FREE FROM DEFECT IN MATERIAL AND WORKMANSHIP, AS LIMITED HEREIN, SHALL BE IN LIEU OF AND EXCLUSIVE OF ALL OTHER WARRANTIES, EITHER EXPRESS OR IMPLIED, WHETHER ARISING FROM LAW, COURSE OF DEALING, USAGE OF TRADE, OR OTHERWISE, THERE ARE NO OTHER WARRANTIES, INCLUDING WARRANTY OF MERCHANTABILITY OR FITNESS FOR PURPOSE, WHICH EXTEND BEYOND THE PRODUCT DESCRIPTION CONFIRMED BY BUYER AND SELLER AS OF THE DATE OF FINAL AGREEMENT.

This warranty is void if the input to the product exceeds the rated input as indicated on the product serial plate by more than 5% on gas-fired and oil-fired units, or if the product in the judgment of SELLER has been installed in a corrosive atmosphere, or subjected to corrosive fluids or gases, been subjected to misuse, negligence, accident, excessive thermal shock, excessive humidity, physical damage, impact, abrasion, unauthorized alterations, or operation contrary to SELLER'S printed instructions, or if the serial number has been altered, defaced or removed.

BUYER'S REMEDY FOR BREACH OF WARRANTY, EXCLUSIVE OF ALL OTHER REMEDIES PROVIDED BY LAW, IS LIMITED TO REPAIR OR REPLACEMENT AT THE FACTORY OF SELLER, ANY COMPONENT WHICH

SHALL, WITHIN THE APPLICABLE WARRANTY PERIOD DEFINED HEREIN AND UPON PRIOR WRITTEN APPROVAL, BE RETURNED TO SELLER WITH TRANSPORTATION CHARGES PREPAID AND WHICH THE EXAMINATION OF SELLER SHALL DISCLOSE TO HAVE BEEN DEFECTIVE; EXCEPT THAT WHEN THE PRODUCT IS TO BE USED BY BUYER AS A COMPONENT PART OF EQUIPMENT MANUFACTURED BY BUYER, BUYER'S REMEDY FOR BREACH, AS LIMITED HEREIN, SHALL BE LIMITED TO ONE YEAR FROM DATE OF SHIPMENT FROM SELLER. FOR GAS-FIRED PRODUCTS INSTALLED IN HIGH HUMIDITY APPLICATIONS AND UTILIZING STAINLESS STEEL HEAT EXCHANGERS, BUYER'S REMEDY FOR BREACH, AS LIMITED HEREIN, SHALL BE LIMITED TO TEN YEARS FROM DATE OF SHIPMENT FROM SELLER.

These warranties are issued only to the original owner-user and cannot be transferred or assigned. No provision is made in these warranties for any labor allowance or field labor participation. Seller will not honor any expenses incurred in its behalf with regard to repairs to any of Seller's products. No credit shall be issued for any defective part returned without proper written authorization (including, but not limited to, model number, serial number, date of failure, etc.) and freight prepaid.

OPTIONAL SUPPLEMENTAL WARRANTY

Provided a supplemental warranty has been purchased, Seller extends the warranty herein for an additional four (4) years on certain compressors. Provided a supplemental warranty has been purchased, Seller extends the warranty herein for an additional four (4) years or nine (9) years on certain heat exchangers.

EXCLUSION OF CONSUMABLES & CONDITIONS BEYOND SELLER'S CONTROL

The above referenced warranty shall not be applicable to any of the following items: refrigerant gas, belts, filters, fuses and other items consumed or worn out by normal wear and tear or conditions beyond Seller's control, including (without limitation as to generality) polluted or contaminated or foreign matter contained in the air or water utilized for heat exchanger (condenser) cooling or if the failure of the part is caused by improper air or water supply, or improper or incorrect sizing of power supply.

Component Applicable Models	"APPLICABLE WARRANTY PERIOD"
Heat Exchangers Gas-Fired Unit Heaters	TEN YEARS FROM DATE OF FIRST BENEFICIAL USE BY BUYER OR ANY OTHER USER, WITHIN TEN YEARS FROM DATE OF RESALE BY BUYER OR ANY OTHER USER, WITHIN TEN YEARS FROM DATE OF RESALE BY BUYER IN ANY UNCHANGED CONDITION, OR WITHIN ONE HUNDRED TWENTY-SIX MONTHS FROM DATE OF SHIPMENT FROM SELLER, WHICHEVER OCCURS FIRST
Heat Exchangers Low Intensity Infrared Units Compressors Condensing Units for Cassettes	FIVE YEARS FROM DATE OF FIRST BENEFICIAL USE BY BUYER OR ANY OTHER USER, WITHIN FIVE YEARS FROM DATE OF RESALE BY BUYER OR ANY OTHER USER, WITHIN FIVE YEARS FROM DATE OF RESALE BY BUYER IN ANY UNCHANGED CONDITION, OR WITHIN SIXTY-SIX MONTHS FROM DATE OF SHIPMENT FROM SELLER, WHICHEVER OCCURS FIRST
Burners Low Intensity Infrared Units Other Components excluding Heat Exchangers, Coils, Condensers, Burners, Sheet Metal	TWO YEARS FROM DATE OF FIRST BENEFICIAL USE BY BUYER OR ANY OTHER USER, WITHIN TWO YEARS FROM DATE OF RESALE BY BUYER IN ANY UNCHANGED CONDITION, OR WITHIN THIRTY MONTHS FROM DATE OF SHIPMENT FROM SELLER, WHICHEVER OCCURS FIRST
Heat Exchangers/Coils Indoor and Outdoor Duct Furnaces and System Units, PSH/BSH, Steam/Hot Water Units, Oil-Fired Units, Electric Units, Cassettes, Vertical Unit Ventilators Compressors Vertical Unit Ventilators Burners High Intensity Infrared Units Sheet Metal Parts All Products	ONE YEAR FROM DATE OF FIRST BENEFICIAL USE BY BUYER OR ANY OTHER USER, WITHIN ONE YEAR FROM DATE OF RESALE BY BUYER IN ANY UNCHANGED CONDITION, OR WITHIN EIGHTEEN MONTHS FROM DATE OF SHIPMENT FROM SELLER, WHICHEVER OCCURS FIRST

As Modine Manufacturing Company has a continuous product improvement program, it reserves the right to change design and specifications without notice.



Commercial Products Group
 Modine Manufacturing Company
 1500 DeKoven Avenue
 Racine, WI 53403
 Phone: 1.800.828.4328 (HEAT)
 www.modinehvac.com
 Litho in USA