



**P&PE**

PUMPS & PROCESS EQUIPMENT INC.

To Request a Quote,

**CALL US 1-847-882-8116**



Always the Right Solution™

Section:  
METERING/DOSING PUMP

Page: 1 of 5

Date: July 2009

## SERVICE MANUAL

# METERING/DOSING PUMP

## BARE SHAFT

A4015A, A4050A, A4100A, AND A4190A, A2400A, and A4400A MODELS

### DESIGN FEATURES

**Suction Housing:** Stainless steel  
**Bearing Housing:** Cast iron  
**Pump Rotor:** Chrome plated, 300 series stainless steel  
**Pump Stator:** Nitrile, EPDM, Fluoroelastomer  
**Shaft:** 300 series stainless steel  
**Bearings:** Pre-lubricated, fully sealed ball bearings  
**Seal:** Single or double mechanical seals, packing  
**Flexible Joint:** Pre-lubricated and sealed

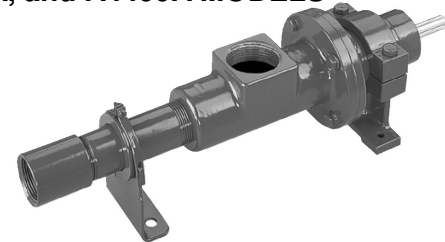

### INSTALLATION

**Mounting.** Provide the proper alignment between the pump and drive by mounting both to a common flat base. Pump may be mounted in any position. When mounting vertically, it is necessary to keep bearings above seals to prevent possible seal leakage into bearings. Loosen screws on body support and stator support to rotate pump to desired position.

**Pre-Wetting.** Prior to connecting pump, wet pump elements and mechanical seal or packing by adding fluid to be pumped into suction port. Turn shaft over several times in a clockwise direction when viewed from the shaft end to work fluid into pump elements.

**Piping.** Piping to pump should be self-supporting to avoid excessive strain on pump housings. The suction port is 1-1/2" NPT and the discharge port is 1-1/4" NPT. Use pipe "dope" or tape to facilitate disassembly and to provide seal.

**Drive.** On belt driven units, adjust belt tension to point of non-slip. Do not overtighten.

On direct drive units, coupling components should be aligned and spaced at least 1/16" apart.

– Pump rotation must be clockwise when facing shaft. –

Check direction of rotation before startup.

– Maximum speed is 1750 rpm.

### OPERATION

**Self-Priming.** With wetted pumping elements, the mechanical seal model pump is capable of 15 feet of suction lift when operating at 1750 rpm with pipe size equal to port size.

**DO NOT RUN DRY.** Unit depends on liquid pumped for lubrication. For proper lubrication, flow rate should be at least 10% of rated capacity.

**Storage.** Always drain pump for extended storage periods using pipe plug in suction housing.

**Pressure Limits.** See Table 1 for maximum discharge pressure of each model.

Table 1

Models	
4015	Max. Pressure 300 PSI, 20 bar
4050	Max. Pressure 300 PSI, 20 bar
4100	Max. Pressure 300 PSI, 20 bar
4190	Max. Pressure 300 PSI, 20 bar
2400	Max. Pressure 175 PSI, 12 bar
4400	Max. Pressure 300 PSI, 20 bar

**Temperature Limits.** Unit is capable for service at 10°F to 210°F with nitrile, and to 260°F with EPDM, and 350°F with fluoroelastomer. Note: an undersize rotor may be required for elevated temperature applications.

### TROUBLESHOOTING

**WARNING: Before making adjustments, disconnect power source and thoroughly bleed pressure from system. Failure to do so could result in electric shock or serious bodily harm.**

#### Failure to Pump.

1. Belt or coupling slip: Adjust belt tension or tighten set screw on coupling.
2. Wrong rotation: Rotation must be clockwise when facing shaft.
3. Excessive suction lift, vacuum or obstruction in suction piping.
4. Flexible joint broken; possible excessive pressure: Replace joint, check pressure at discharge port.

#### Will Not Start.

1. Insufficient horsepower: Check motor starting torque for minimum model starting torque given on performance curves.
2. Low voltage: Check power supply.

**Noisy Operation.**

1. Starved suction: Check fluid supply, length of suction line, and obstructions in pipe.
2. Bearings worn: Replace parts; check alignment, belt tension, pressure at discharge port.
3. Broken flexible joint: Replace part; check pressure at discharge port.
4. Insufficient mounting: Mount to firm base. Vibration-induced noise can be reduced by using mount pads and hose on suction and discharge ports.

**Pump Overloads.**

1. Excessive discharge pressure: Check discharge pressure for maximum rating given in Table 1. Check for obstruction in discharge pipe.
2. Excessive temperature.
3. Belt or coupling slip: Check pressure at discharge port.
4. Loose bond in stator: High temperature and caustics will cause bond between rubber and tube to fail. Replace stator. Check fluid temperature and pressure at discharge port.
5. Fluid viscosity too high: See chart below for recommended maximum RPM.

Viscosity CP	Limit RPM
1-1,000	1750
1,000-2,500	1200
2,500-5,000	600
5,000-10,000	300
10,000-20,000	175
20,000-50,000	80

Based on 60% min. volumetric efficiency. See PEC449 or consult Moyno representative for exact values.

6. Motor connected incorrectly: Motor wired for 230 VAC, connected to 115 VAC service.

**Poor Performance.**

1. Low pressure; worn stator: Replace stator: Check for excessive abrasive material in fluid. Check for run dry condition.

**Mechanical Seal Leakage.**

1. Leakage at startup: If leakage is slight, allow pump to run several hours to let faces run in.
2. Persistent seal leakage: Faces may be cracked from freezing or thermal shock. Replace seal.

**Pump Will Not Prime.**

1. Air leak on suction side: Check pipe connections. Suction lift over 15 ft. will cause seal faces to open.
2. Defective mechanical seal: Inspect and repair as necessary.

**MAINTENANCE**

**General.** These pumps have been designed for a minimum of maintenance. The pump is one of the easiest to work on in that the main elements are very accessible and require few tools to disassemble.

**Bearing Lubrication.** The prelubricated, fully sealed bearings do not require additional lubrication.

**PUMP DISASSEMBLY**

**WARNING: Before disassembling pump, disconnect power source and thoroughly bleed pressure from system. Failure to do so could result in electric shock or serious bodily harm.**

1. Disconnect power source.
2. Remove suction and discharge piping.
3. Discharge coupling (9) may be removed from stator (21) by unscrewing in a counter-clockwise direction (RH thread).
4. Remove stator support clamp screw and remove top half of stator support (38).
5. Stator (21) may be removed from suction housing (2) by unscrewing in a counter-clockwise direction (RH thread). Use strap wrench on stator to avoid crushing with a pipe wrench. Pull stator (21) from rotor (22). To assist removal of stator, hold drive shaft (26) from turning and turn stator clockwise when facing suction housing after disengaging thread.
6. Remove screws (112) holding suction housing (2) to bearing housing (1) or adapter (74). Remove suction housing and suction housing gasket (83). Gaskets on cast iron models only. Remove O-Ring (270) on other models.
7. The rotor (22) and flexible joint (24) may be removed using the following procedure (do not bend joint more than 15 degrees).
  - a. Remove rotor (22) from flexible joint (24) by using a punch to remove rotor shaft pin (46). Support joint while removing pin.
  - b. Remove joint (24) from shaft (26) by using a punch to remove shaft pin (46).
8. **Single Mechanical Seal Models.** Carefully slide mechanical seal (69) off shaft (26). Carefully pry seal out of bearing housing (1), or seal housing (3). Remove seal housing if pump is a stainless model.

**Double Mechanical Seal Models.** Carefully slide seal housing (71) from the drive shaft. Remove rotational part of mechanical seal from the shaft. Carefully remove seal gland (73) from adapter. Remove stationary seal faces if required.

If any parts of mechanical seal are worn out or broken, the complete assembly should be replaced. Seal components are matched parts and are not interchangeable.

**Packing Models.** Slide stuffing box assembly from the shaft. Remove packing gland halves and replace packing.

9. The bearings (29) and shaft (26) assembly can be removed from bearing housing (1) after snap ring (66) has been removed. To remove the shaft assembly, lightly tap the shaft at the flexible joint connection end using a block of wood to protect the shaft. The bearings may be pressed off the shaft.

**PUMP ASSEMBLY**

1. Press bearings (29) on shaft (26), and locate slinger ring (77) on the shaft near the radial bearing.

**NOTE:** When replacing bearings, always press on the inner race when assembling to shaft, and on the outer race when pressing bearings into the housings.

2. Press shaft assembly into bearing housing (1) securing with snap ring (66).
3. On stainless steel models install seal housing (3) in bearing housing with O-Ring (270) installed in the O-Ring groove.

On packing models install stuffing box assembly (stuffing box, packing, and packing gland) on shaft with O-ring (270) installed in the O-ring groove.

4. Install mechanical seal (69) or (70) using the following procedure:

a. Clean and oil sealing faces using a clean light oil (not grease).

**CAUTION: Do not use oil on EPDM parts. Substitute glycerin or soap and water.**

b. Oil the outer surface of the seal seat, and push the assembly into the seal bore in the bearing housing (1), or seal gland and housing, seating it firmly and squarely. On double seal models install seal gland on shaft.

c. After cleaning and oiling shaft, slide the seal body along the shaft until it meets the seal seat.

d. Install seal spring and spring retainer or seal housing with O-rings (72 and 270) on shaft.

5. The flexible joint (24) and rotor (22) may be installed using the following procedure (do not bend joint more than 15 degrees):

a. Pin flexible joint (24) to shaft (26) using the shaft pin (46).

b. Pin rotor (22) to joint using rotor pin (46). Support joint while installing pin.

6. Secure suction housing gasket (83) (cast iron pumps only) and suction housing (2) to bearing housing (1) using lock washers (215) and screws (112).

7. Slide stator support retainer (39) on stator (21).

8. Screw coupling (9) on stator (21) in a clockwise direction (RH thread).

**NOTE:** Apply pipe "dope" on all pipe threads before assembly.

9. Lubricate rotor (22) surface to assist installation of stator (21). Slide stator on rotor, and screw into suction housing (2) by turning clockwise (RH threads). An additional assist in installing stator is to lock the shaft from turning and rotate the stator counter-clockwise while pushing towards suction housing.

10. Secure clamp assembly (40) to the stator support (38) and the support retainer (39) using the clamp assembly (40) screw.

11. Proceed as in installation instructions.

**WARNING: Replace belt or coupling guards before reconnecting power.**

**When ordering parts**, please specify pump model number, pump serial number, part number, part description and quantity.

### Double Seal Models

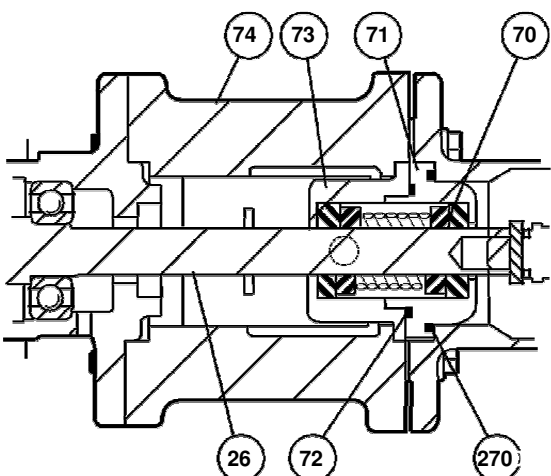

### Packing Models

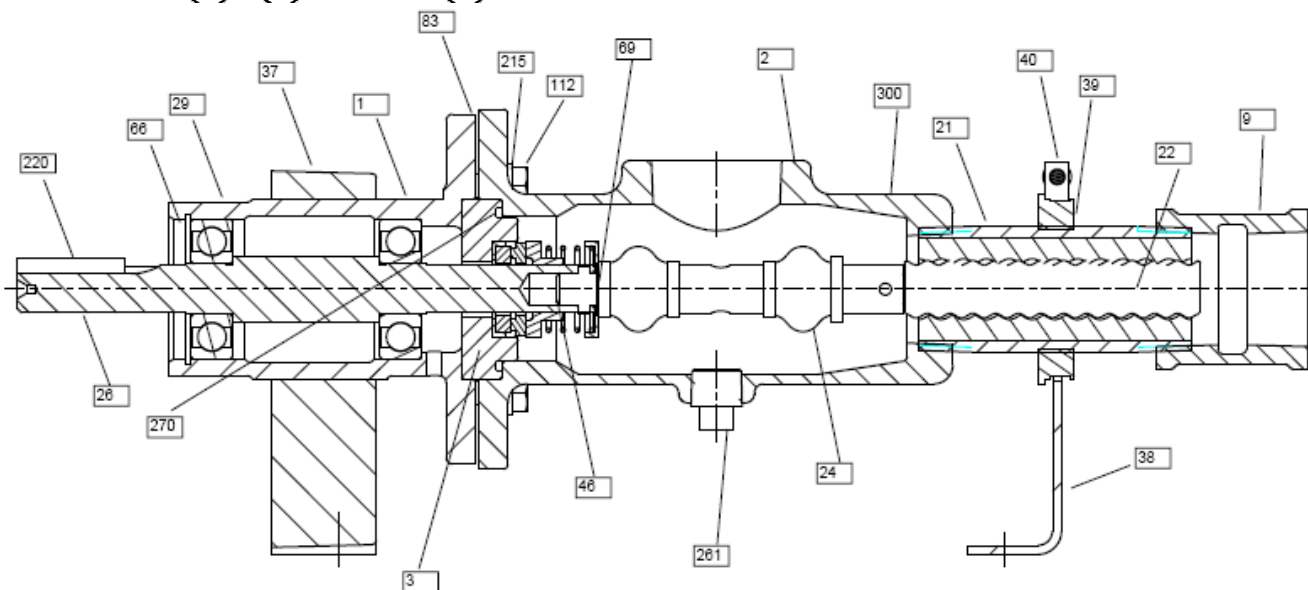
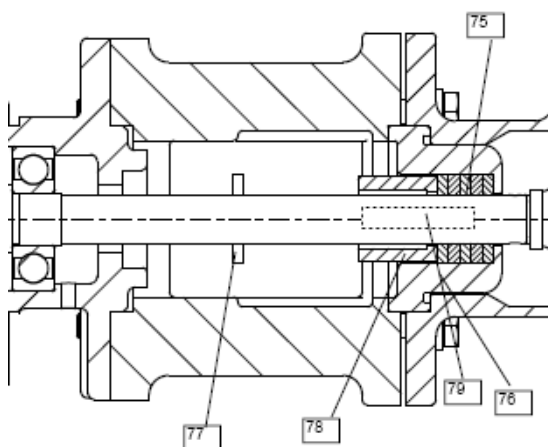

Note: Item 83 is used on cast iron only.

**BARE SHAFT MODELS PARTS LIST**

Item	Type	Description	Qty	A4015, A4050, A4100, A4190, A2400, A4400
1	CD	Bearing Housing	1	3308813000
2	SS	Suction Housing	1	3403932007
3	CD/SS	Seal Housing	1	3403930007
9	SS	Discharge Coupling	1	3205342020
21	See Table	Stator	1	See Stator Table
22	See Table	Rotor	1	See Rotor Table
24	Q,R,B,F	Flexible Joint	1	3308811005
26	SS	Drive Shaft	1	3303577002
29	SS	Bearing	2	6300503031
37	SS	Body Support	1	3403947001
38	SS	Stator Support	1	3403945001
39	SS	Stator Support Retainer	1	3201733000
40	SS	Clamp Assembly	1	3204277000 and 3201734000
46	SS	Rotor/Shaft Pin	2	3204069001
66	SS	Snap Ring	1	3205162000
69	Q,R,B,F	Mech Seal (Cbn vs Cer)	1	3206501000
69	Q,R,B,F	Mech Seal (AR)	1	3206503000
70	Q,R,B,F	Double Mechanical Seal	1	3208652002
71	SS	Seal Housing, Double	1	3403986015
72	Q,R,B,F	O-Ring	1	3207902128
73	SS	Seal Gland, Double	1	3403985015
74	SS	Adapter	1	3501688004
75	SS	Packing Set	1	3403396002
76	SS	Suffing Box	1	3403934007
77	SS	Slinger Ring	1	3206382000
78	SS	Packing Gland Half	2	3403933007
79	SS	Packing Gland Stud	2	3208591000
83	Q,R,B,F	Housing Gasket	1	3203028005
112	SS	Screw	4	6191520141
215	SS	Lock Washer	4	6230010401
261	SS	Drain Plug	1	6100420030
270	Q,R,B,F	O-Ring	1	3207905134
300	SS	Nameplate	1	3208597000

<b>Stator Material</b>			
<b>Element</b>	<b>Q (Nitrile)</b>	<b>B (EPDM)</b>	<b>F (Fluoro)</b>
<b>4015</b>	3403923104	3403923304	3403923504
<b>4050</b>	3202145013	3203676013	3303719013
<b>4100</b>	3403924104	3403925304	3403924504
<b>4190</b>	3403925104	3403925304	3240392504
<b>2400</b>	4252489102	4252489302	425489502
<b>4400</b>	4252489104	4252489304	4252489504

<b>Rotor</b>	
<b>Element</b>	<b>300 Series SS and CD</b>
<b>4015</b>	3403927015
<b>4050</b>	4252492015
<b>4100</b>	3403928015
<b>4190</b>	3403929015
<b>2400</b>	4252524015
<b>4400</b>	4252491015

For further information, call:  
 Inside U.S.A. - 800-845-1310 or 800-325-1331  
 Outside U.S.A. - 937-327-3553