

POWERFACTOR 3

DIGITAL POWER AMPLIFIER

POWERFACTOR 5

DIGITAL POWER AMPLIFIER

POWERFACTOR 7

DIGITAL POWER AMPLIFIER



2nd Edition

SERVICE MANUAL

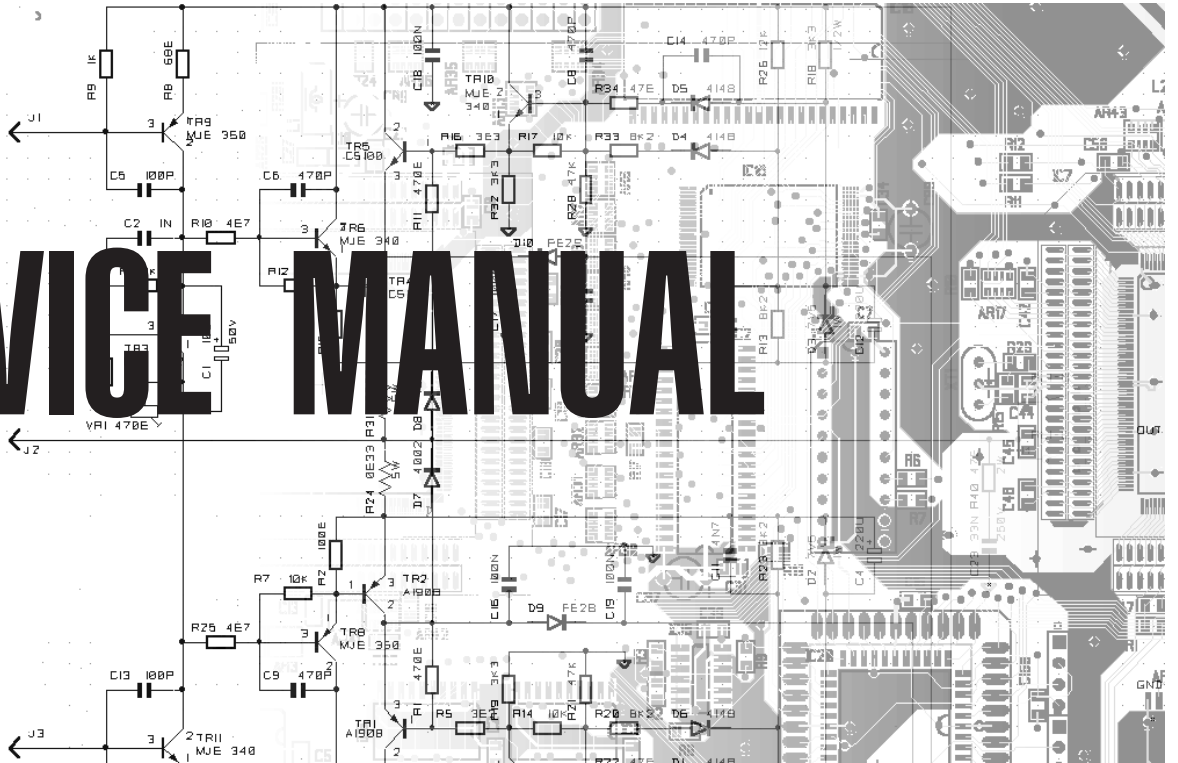

▶ CODE: 270242 ◀

Assistance Procedure

WARRANTY CONDITIONS

The GM warranty validity will depend on the integrity of the seal applied on the cover's edge (back side) of each product, which must not be broken or removed for any reason by the user and/or the GM Service Centre, otherwise the validity will be lost as penalty.

FIRST LEVEL ASSISTANCE SERVICE (made by GM Service Center)

The seal includes all the electronics of the power amplifier module with the exception of the Lem control panel assembly, which is accessible by means of four screws with hexagonal head.

We therefore authorize only the first level assistance relevant to the Lem control panel assembly (see the spare parts mentioned below) and to the faultiness checking of the power amplifier module.

SECOND LEVEL ASSISTANCE SERVICE (made by GM Italy)

The second level assistance on the amplifier will be made directly by GM Italy. The distributor/service centre will have to send GM Italy the faulty equipment and GM Italy will ship the equipment under temporary replacement, if requested.

PROCEDURE (made by GM Service Center)

The correct procedure for getting a second level assistance is the following one:

- 1) Please fill in properly the SERVICE CARD with all data required, particularly specify the S/N relating to the Powerfactor to be repaired and briefly explaining its faultiness and stating exactly whether the equipment (under temporary replacement) is required or not.
- 2) Kindly fax to GM Italy (S.A.T. Dept.) the SERVICE CARD and the WARRANTY CARD properly compiled (only for equipment which are under guarantee) in order to have the GM authorization and the indications to manage the repairing.
NOTE: The WARRANTY CARD must be filled in the properly way otherwise its validity will be lost.
- 3) The GM Italy (S.A.T. Dept.) will authorize by fax the shipment of the equipment to be repaired and a possible confirmation about a new equipment to send you under temporary replacement.

REPAIRING AND FREIGHT CHARGES

- 1) The freight charges relating to the **temporary** equipment will be always debited to the final user.
- 2) The repairing costs of equipment **under warranty** will be charged to GM Italy.
- 3) The repairing costs and the freight charges of equipment **out of warranty** will be invoiced by GM Italy to the addressee within 30 days starting from the equipment return.

OTHER CONDITIONS

- 1) GM Italy answers for the equipment repairing and the relating shipment to the addressee within 30 days from the receipt date of the same equipment.
- 2) The temporary equipment ought to be sent back to GM Italy within 5 days from receipt of the repaired one. *In case the temporary equipment should not return to GM Italy, it will be automatically invoiced after 30 days from the date of the repaired equipment shipment.*

Spare Part List

Ref	Code	Description
	277339	Owner's Manual (English, Italian)
	PWS887000	Mains Cable with Neutrik NAC3FCA plug
1	PWS667003	"Lem" Rack Support (ME000017)
2	PWS667000	PowerFactor 3 Control Panel (ME000018)
3	PWS667001	PowerFactor 5 Control Panel (ME000018)
12	PWS667005	PowerFactor 7 Control Panel (ME000018)
4	PWS110000	Power Switch (IN000001)
5	PWS667004	Potentiometer Knob (MA000001)
6	PWS768000	Controls Panel PCB Assembly (DA22 FR04)
7	PWS100000	LM3915N Vu-Meter IC (IC000015)
8	PWS074000	470ohm Lin Rot Potentiometer (PO000001)
9	PWS080002	Green Led (LE000005)
10	PWS080000	Yellow Led (LE000003)
11	PWS080001	Red Led (LE000004)

Fax directly to GM Italy: + + 39-(0)541-957-404

Address

 **GENERALMUSIC S.p.A. Sales Division: 47842 S.Giovanni in Marignano (RN) ITALY - Via delle Rose, 12**

 **Phone + 39(0)541/959511 - Fax + 39(0)541/957404 - GENERALMUSIC on the NET: <http://www.generalmusic.com>**

Use a hexagonal rod spanner of 2.5mm to uncrows the fixing screws of the rack support control panel.

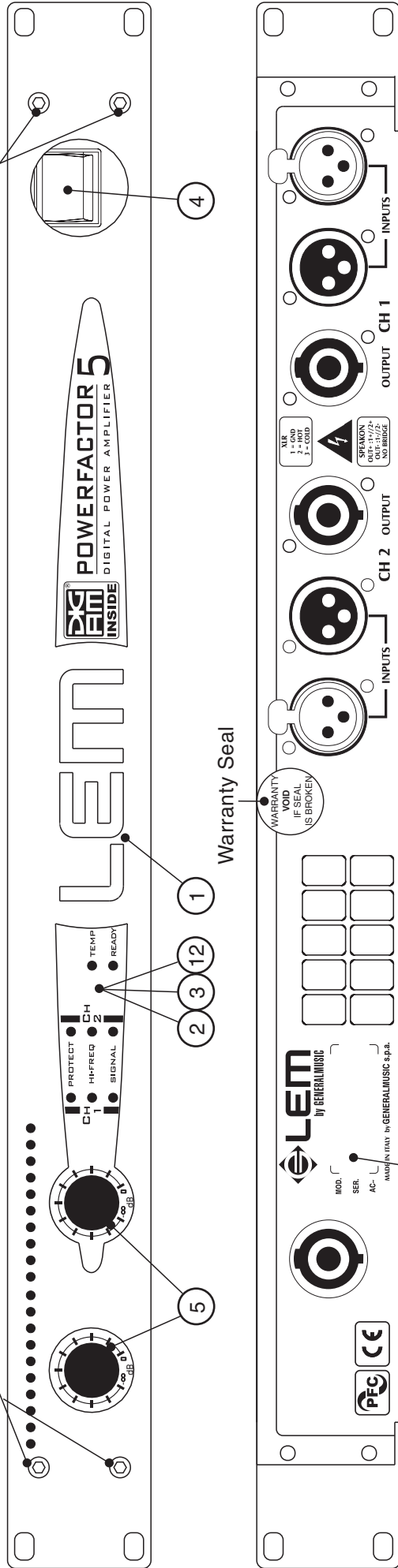

Model
Serial Number
AC supply specifications

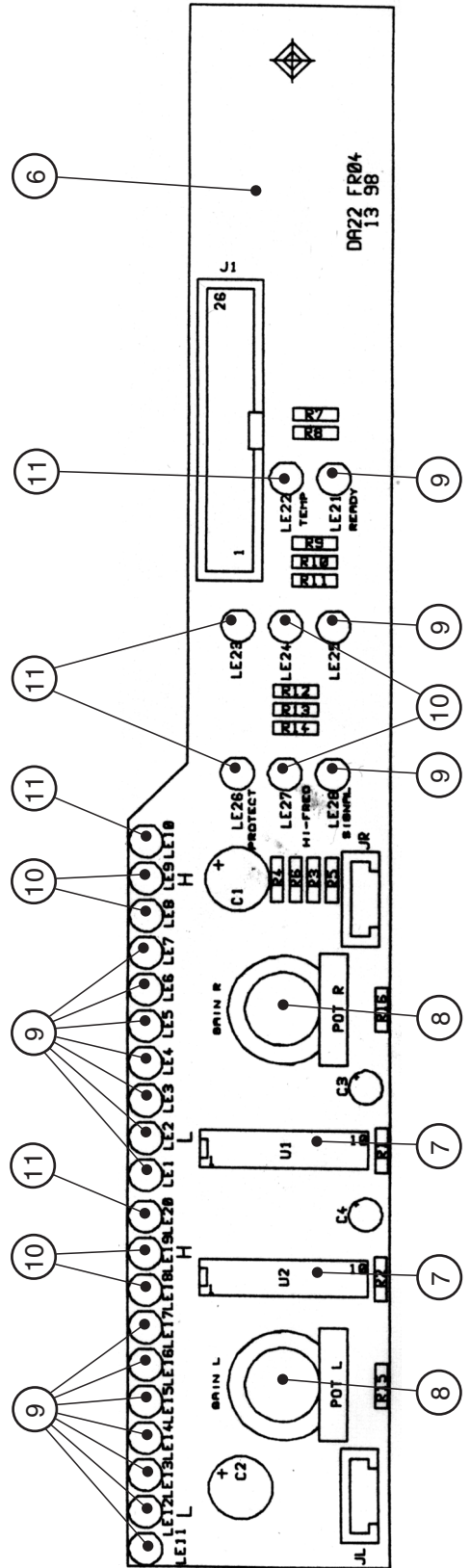

POWER AMPLIFIER MODULE CH1

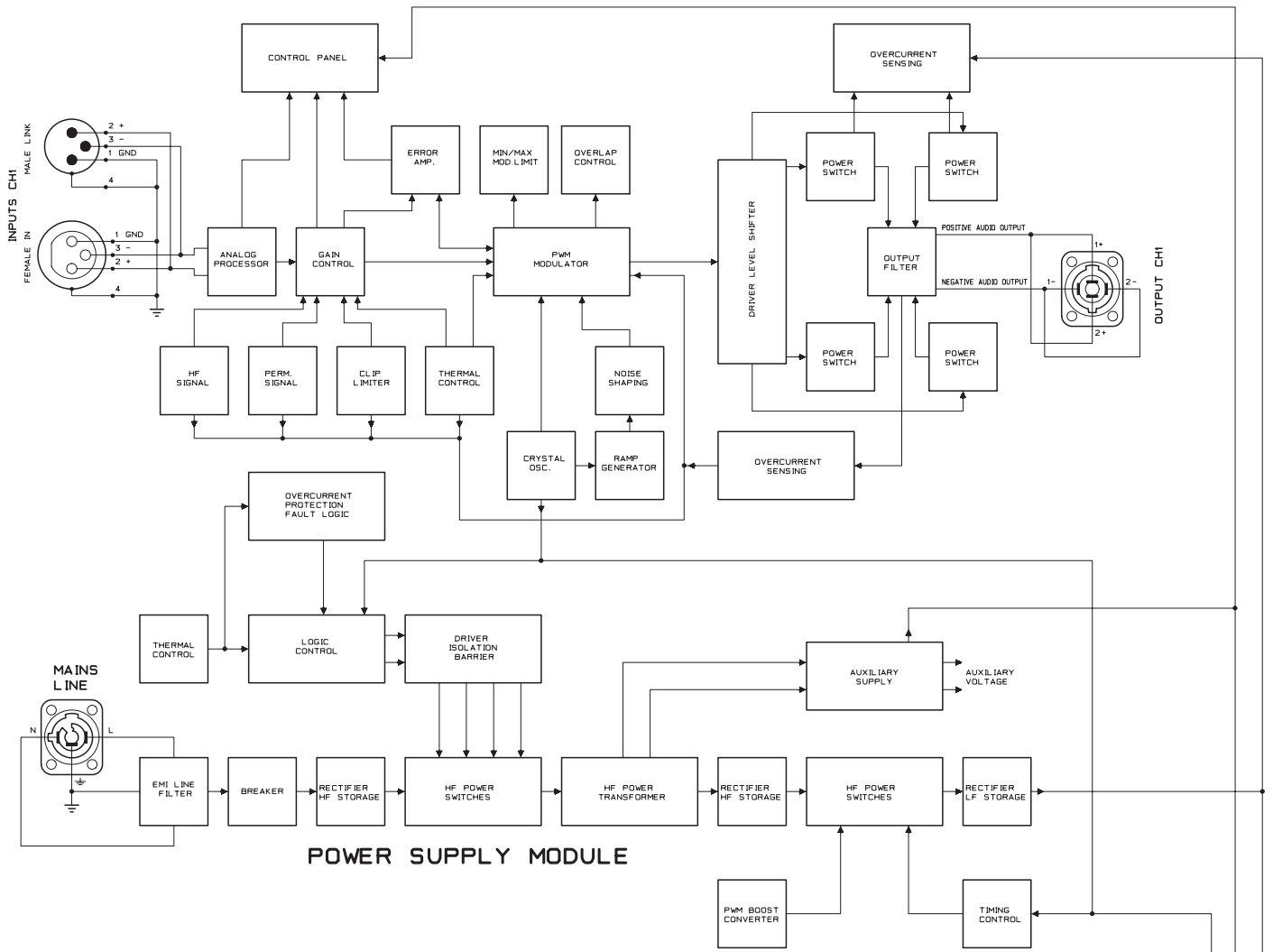

POWER SUPPLY MODULE

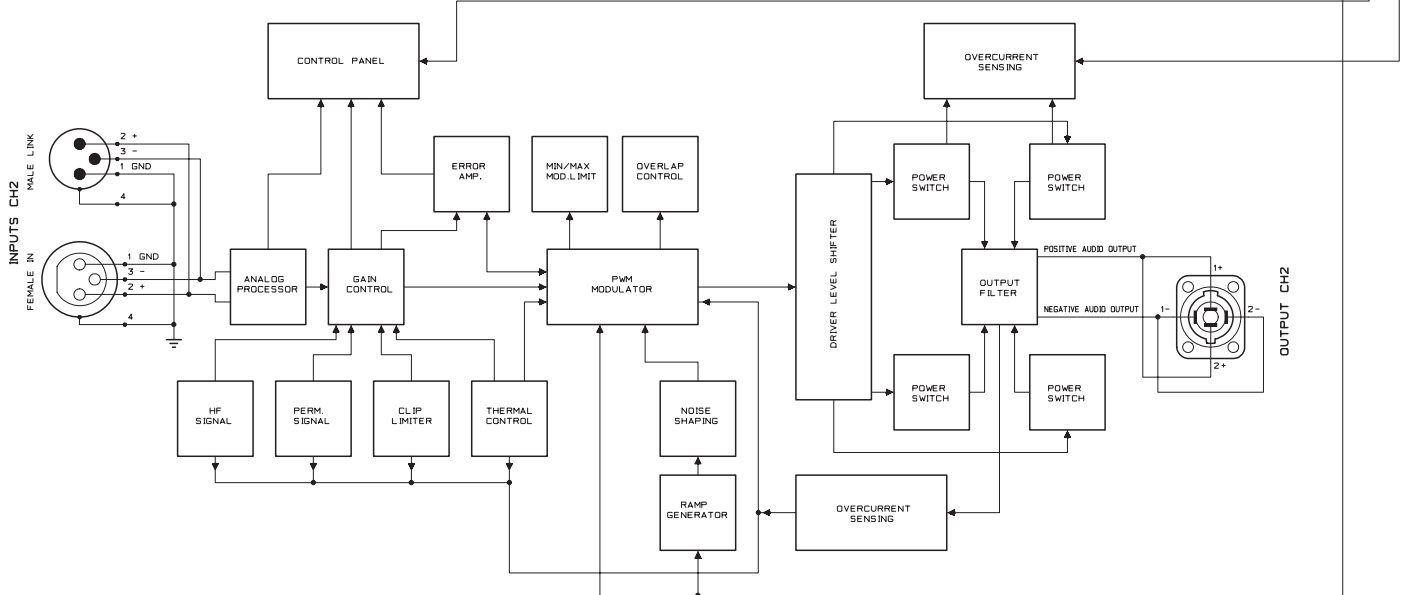

POWER AMPLIFIER MODULE CH2

DRW BOCCATO	DWG# 550645	PCB#	GENERALMUSIC S.p.A. ITALY
CKD	DSK# 6 PART: 1/1	SCHEMATIC DIAGRAM POWERFACTOR 3/5/7	ALL RIGHTS ARE RESERVED. NO COPIES OR REPRODUCE THIS DOCUMENT WITHOUT WRITTEN CONSENT BY GENERALMUSIC.
APP	REV: 16/03/00	BLOCK DIAGRAM	

POWERFACTOR SERIES • TECHNICAL SPECIFICATIONS

POWER SPECIFICATIONS		POWERFACTOR 3	POWERFACTOR 5	POWERFACTOR 7
EIAJ impulse output power 1kHz, THD maximum 1% Both channels	2 Ohms	1500+1500	2500+2500	3500+3500
	4 Ohms	820+820	1360+1360	1910+1910
	8 Ohms	450+450	750+750	1050+1050
Efficiency (at any sound level)	95%	DIGAM (DIGital AMplifier) and PWM (Pulse Width Modulation), "Full Switching" output amplification stage using a 250KHz sampling rate, new D/A power conversion and other dedicated devices are the circuits used in these high technology amplifiers to achieve their high performances.		

ELECTRICAL SPECIFICATIONS				
INPUT SENSITIVITY		0dB (0.775Vrms)		
INPUT IMPEDANCE		10 kOhms (balanced)		
FREQUENCY RESPONSE		10÷40000 Hz (-0.5dB)		
VOLTAGE GAIN		+38 dB	+40 dB	+41 dB
SLEW RATE		50 V/μs		
DAMPING FACTOR		100Hz = 400, 10kHz = 400		
CROSSTALK		-90 dB		
S/N ratio		-100 dB		
Harmonic distortion THD		<0.5% from 0.1W to full power (typical <0.1%)		
Intermodulation distortion SMPTE		<0.5% from 0.1W to full power (typical <0.1%)		
Intermodulation distortion DIM 100		<0.02% from 0.1W to full power (typical <0.01%)		

PROTECTIONS	
AMPLIFIER	<p>Short circuit and over current protection for loads < 2ohm. When the protection trips the led PROTECT lights up and the relative channel is muted.</p> <p>Thermal protection with three operating levels:</p> <p>1) Normal condition: The fan flow air from front to rear slits according with the temperature level. To ensuring the normal condition the airflow must be unobstructed from rack, fly-cases or dust.</p> <p>2) Safety condition: When the temperature reaches 60°C the protection circuit gradually reduces the output gain and the TEMP led flashes.</p> <p>3) Protected condition: When the temperature exceeds 70°C all the channels are muted until safe temperature level is restored, the TEMP led lights steadily.</p> <p>DC offset current protection. When the protection trips the led PROTECT lights up and the relative channel is muted.</p>
LOUDSPEAKERS	<p>Muting circuit at Power on and off.</p> <p>High-frequency protections. Two dedicated device, one for each channel, filters internal VHF signals and external RF interferences outside the audio range, its activity is indicated by means of HI-FREQ leds.</p> <p>Soft Clipping protections. Two clip limiters, one for each channel, prevent distortions due to excessive input signals. Their activities are displayed by the VU-Meters:</p> <p>Green leds indicate normal running conditions.</p> <p>First yellow led lights up at -3dB.</p> <p>Second yellow led lights up at 0dB.</p> <p>Red Led lights up at +4dB and indicates the interventions of the soft clip circuit, it must lights up only occasionally.</p>

POWERFACTOR SERIES • TECHNICAL SPECIFICATIONS

GENERAL SPECIFICATIONS		POWERFACTOR 3	POWERFACTOR 5	POWERFACTOR 7
CONTROLS		ON/OFF switch Input level control for each channel		
INDICATORS		SIGNAL LEVEL: 2 x 10-LED bar PROTECT: 2 red LEDs HI-FREQ: 2 yellow LEDs SIGNAL: 2 green LEDs ON/READY: 1 green LED TEMP: 1 red LED		
CONNECTORS	INPUT	1 XLR-F + 1 XLR-M in parallel for each channel		
	OUTPUT	1 4-way SPEAKON for each channel		
POWER SUPPLY	Europe	230Vac ±15%		
	U.S.	115Vac ±15%		
	Power requirement	2000W	3400W	4800W
	SSC	The "Soft Start Circuit" is a device that allows to avoid high energy consumption when the unit is switched on.		
	APFC	The "Active Power Factor Correction" circuit, parts of the switching supply circuit, simulates a pure resistive load on the mains line, this permits to ensure almost total stabilization of the supply voltage of the output stage, obtaining a perfect dynamic capacity on PA systems without over-dimension the power supply of the mains line.		
MAINS CABLE		Supplied with the unit and terminated with a Neutrik Powercon (type NAC3FCA) at unit side, the other side (mains line) must be equipped with a right plug at least 20A current capacity and respecting the following connections: Blue wire = N - Neutral Brown wire = L - Line Green/Yellow =  Earth / Ground		
DIMENSIONS		483x44x450 mm (WxHxD)		
WEIGHT		9.5 kg		



ATTENTION

These amplifiers cannot be used in bridge mode, this is due to the PWM final stage structure.

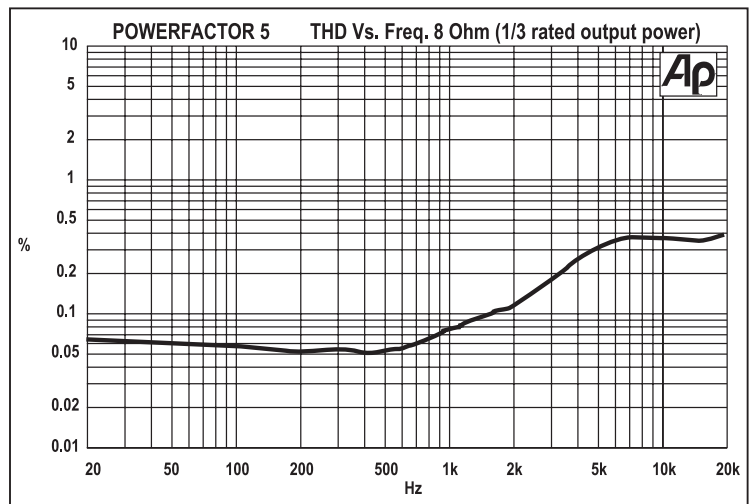
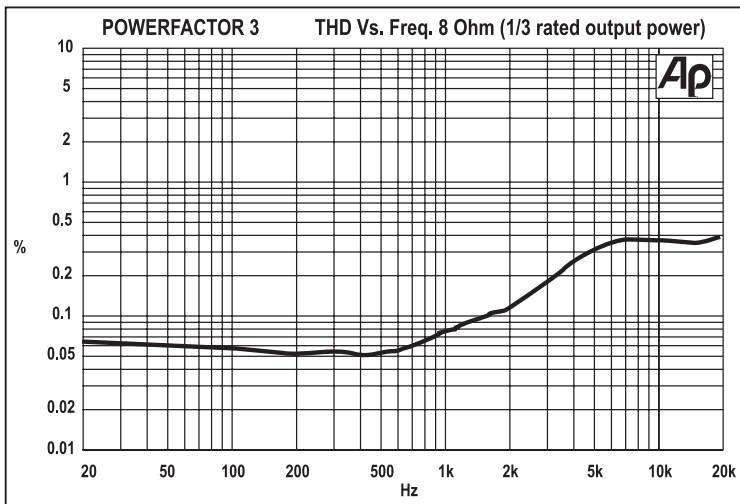
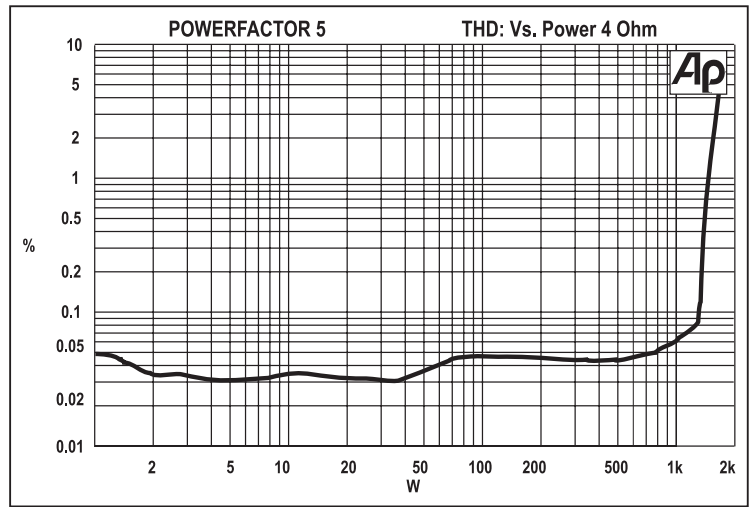
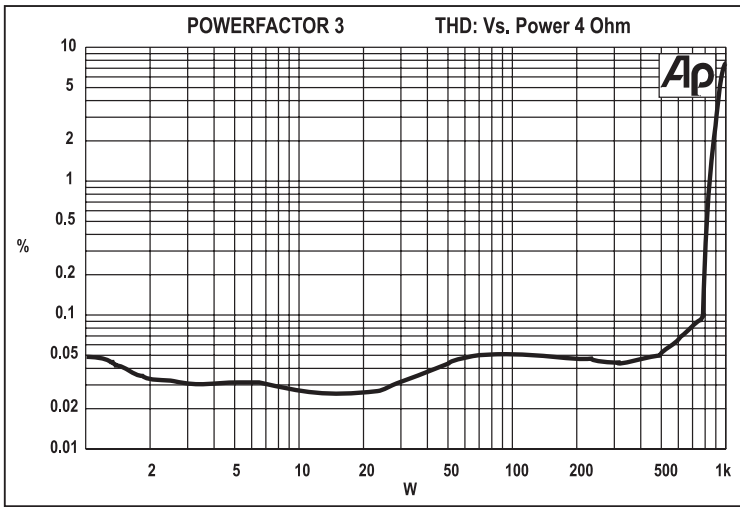
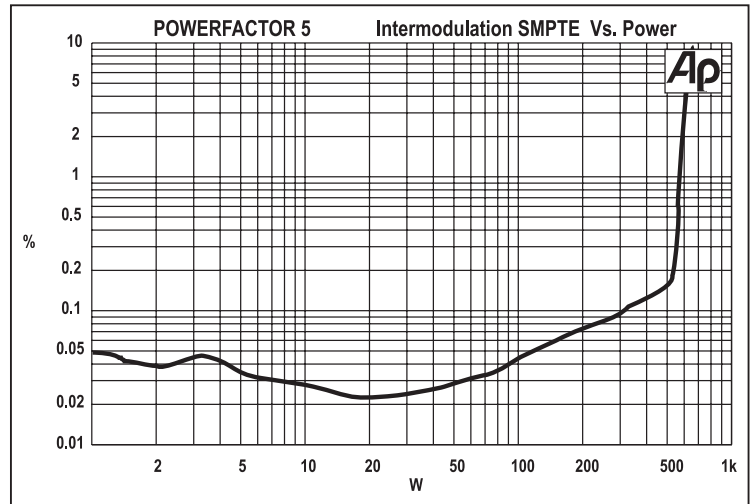
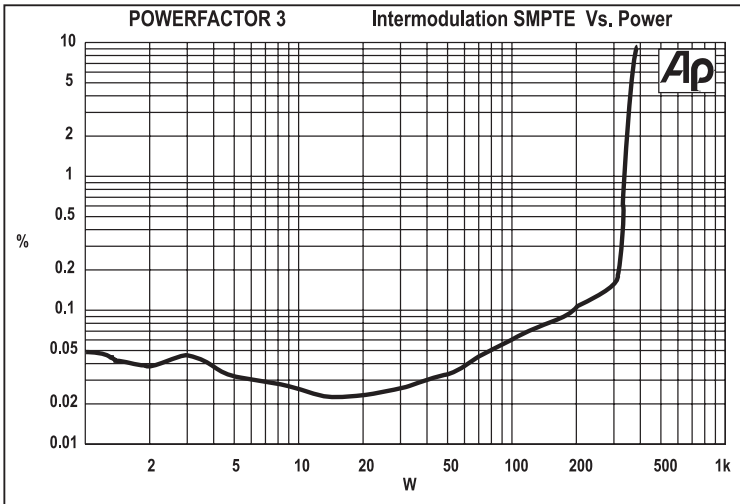
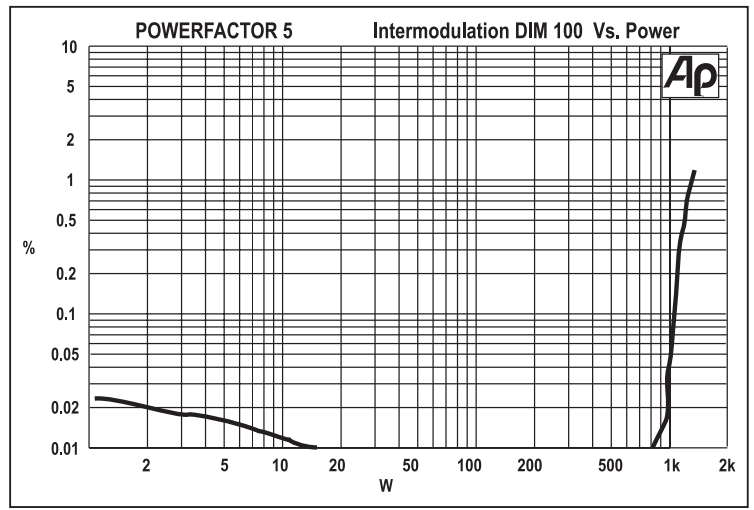
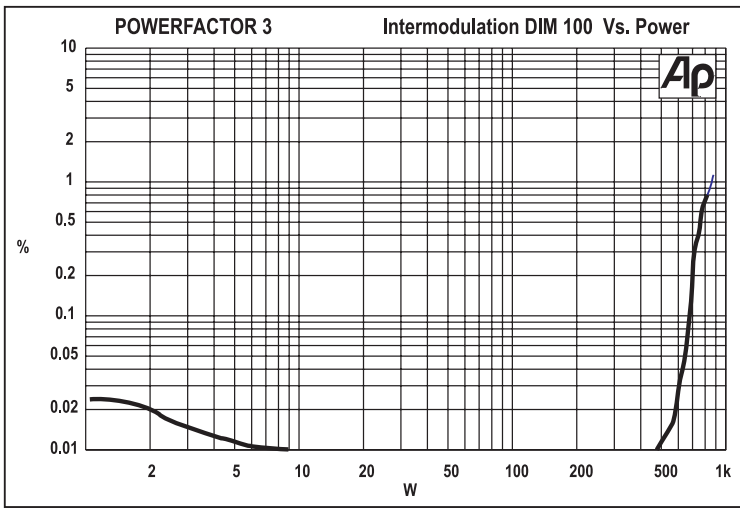

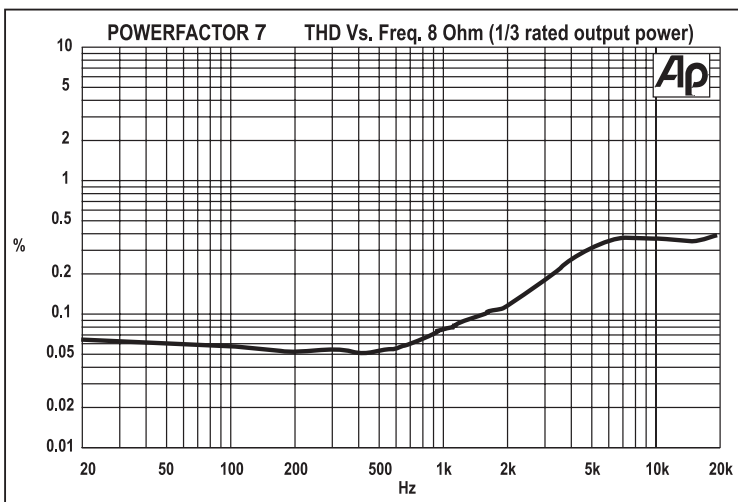
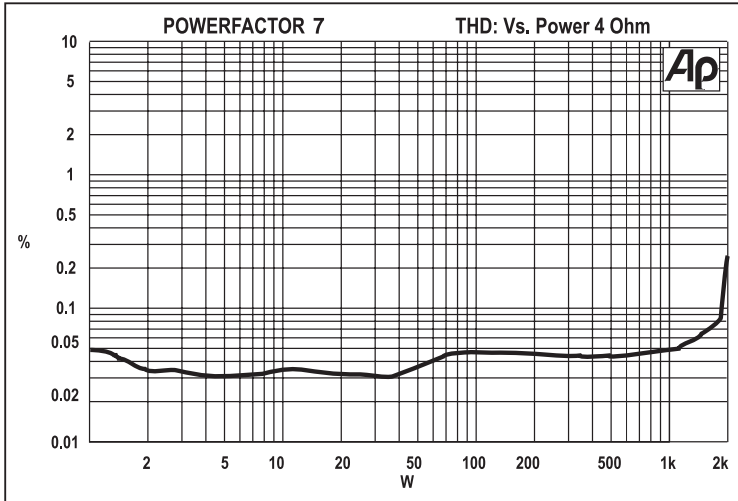
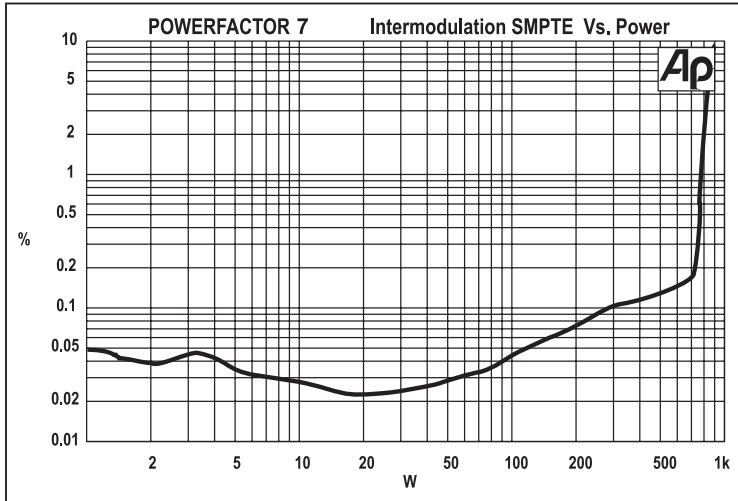
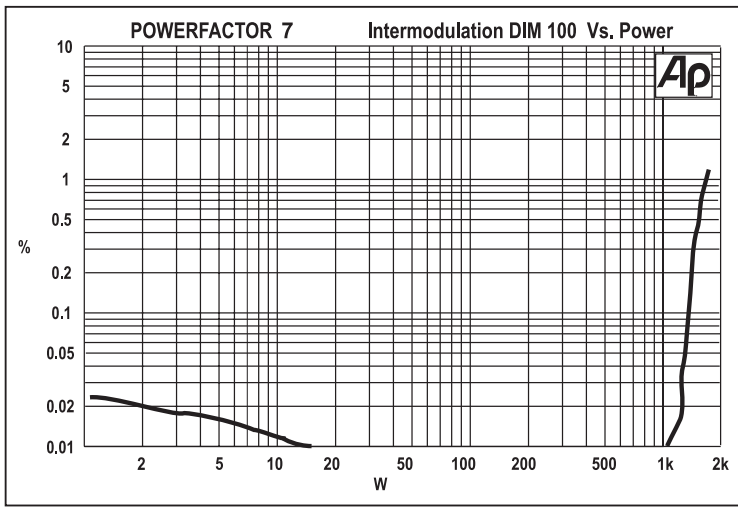

THIS PAGE IS INTENTIONALLY LEFT BLANK.

Fax to: ++39-(0)541-957-404 GENERALMUSIC S.p.A. Italy (Att. S.A.T. Department)

SERVICE REQUEST: fill in by Service Center**MODEL :** **SER.N° :**

NOTE: fill in with defective equipment data as referred exactly in the back label.

Under Warranty ? **YES** **NO**

NOTE: if YES, fax the WARRANTY CERTIFICATE also.

Brief explanation of defect:

.....

.....

.....

Service Center (addressee)

Name :

Address :

Post code : City: Country:

Phone : Fax:

VAT registration number (EU countries only):

Date : Sign & Stamp:

Request of temporary equipment : **YES** **NO**

NOTE: all freight charges of temporary equipment is always debited to the final customer.

REPAIRING AUTHORIZATION: fill in by GM Italy**Authorization N°:** Ship the defective unit to the below address and shipment conditions:

Date : Sign & Stamp:

Temporary equipment references (if requested):**MODEL :** **SER.N° :**

Delivered by means of :

Shipment referement :

REPAIRING INFO: fill in by GM Italy

Delivered by means of : Date:

Shipment referement : Cost:

TEMPORARY EQUIPMENT RETURNING INFO: fill in by SERVICE CENTER

Delivered by means of : Date:

Shipment referement :

NOTE: Fax the shipment info only just you have delivered the temporary equipment at the carrier.

Fax a: ++39-(0)541-957-404 GENERALMUSIC S.p.A. Italy (Att. S.A.T. Department)

RICHIESTA DI ASSISTENZA: compilata dal Centro Assistenza _____

Autorizzato

MODELLO : **SER.N°** :

NOTA: compilare con i dati dell'apparecchio difettoso come riportati esattamente nella targhetta posteriore.

In Garanzia ? **SI** **NO**

NOTA: se SI faxare anche il Certificato di Garanzia.

Breve spiegazione del difetto:

.....
.....
.....**Centro di Assistenza (mittente)**

Nome :

Indirizzo :

Codice Postale : Citta': Provincia:

Telefono : Fax:

Partita IVA:

Data : Firma e Timbro:

Richiesta dell'apparecchio temporaneo : **SI** **NO**

NOTA: tutte le spese di spedizione dell'apparecchio temporaneo sono sempre a carico del cliente finale.

AUTORIZZAZIONE RIPARAZIONE: compilata da GM Italia _____**N° Autorizzazione:** Inviare l'unita' difettosa all'indirizzo con le modalita' di spedizione specificati:

Data : Firma e Timbro:

Riferimenti dell'apparecchio temporaneo (se richiesto):**MODELLO** : **SER.N°** :

Consegnato tramite :

Riferimento spedizione :

INFORMAZIONI RIPARAZIONE: compilata da GM Italia _____

Consegnato tramite : Data:

Riferimento spedizione : Costo:

INFORMAZIONI RESTITUZIONE APPARECCHIO TEMPORANEO: compilata dal Centro Assistenza Autorizzato _____

Consegnato tramite : Data:

Riferimento Spedizione :

NOTA: Faxare queste info sulla spedizione solo quando avrai consegnato l'apparecchio temporaneo al corriere.

Fax to: ++39-(0)541-957-404 GENERALMUSIC S.p.A. Italy (Att. S.A.T. Department)

SERVICE REQUEST: fill in by Service Center _____

MODEL : **SER.N° :**

NOTE: fill in with defective equipment data as referred exactly in the back label.

Under Warranty ? **YES** **NO**

NOTE: if YES, fax the WARRANTY CERTIFICATE also.

Brief explanation of defect:

.....

.....

.....

Service Center (addressee)

Name :

Address :

Post code : City: Country:

Phone : Fax:

VAT registration number (EU countries only):

Date : Sign & Stamp:

Request of temporary equipment :

YES

NO

NOTE: all freight charges of temporary equipment is always debited to the final customer.

REPAIRING AUTHORIZATION: fill in by GM Italy _____

Authorization N°: Ship the defective unit to the below address and shipment conditions:

Date : Sign & Stamp:

Temporary equipment references (if requested):

MODEL : **SER.N° :**

Delivered by means of :

Shipment referement :

REPAIRING INFO: fill in by GM Italy _____

Delivered by means of : Date:

Shipment referement : Cost:

TEMPORARY EQUIPMENT RETURNING INFO: fill in by SERVICE CENTER _____

Delivered by means of : Date:

Shipment referement :

NOTE: Fax the shipment info only just you have delivered the temporary equipment at the carrier.

Fax a: ++39-(0)541-957-404 GENERALMUSIC S.p.A. Italy (Att. S.A.T. Department)

RICHIESTA DI ASSISTENZA: compilata dal Centro Assistenza _____

Autorizzato

MODELLO : **SER.N°** :

NOTA: compilare con i dati dell'apparecchio difettoso come riportati esattamente nella targhetta posteriore.

In Garanzia ? **SI** **NO**

NOTA: se SI faxare anche il Certificato di Garanzia.

Breve spiegazione del difetto:
.....
.....

Centro di Assistenza (mittente)

Nome :

Indirizzo :

Codice Postale : Citta': Provincia:

Telefono : Fax:

Partita IVA:

Data : Firma e Timbro:

Richiesta dell'apparecchio temporaneo : **SI** **NO**

NOTA: tutte le spese di spedizione dell'apparecchio temporaneo sono sempre a carico del cliente finale.

AUTORIZZAZIONE RIPARAZIONE: compilata da GM _____

Italia

N° Autorizzazione: Inviare l'unita' difettosa all'indirizzo con le modalita' di spedizione specificati:

Data : Firma e Timbro:

Riferimenti dell'apparecchio temporaneo (se richiesto):

MODELLO : **SER.N°** :

Consegnato tramite :

Riferimento spedizione :

INFORMAZIONI RIPARAZIONE: compilata da GM _____

Italia

Consegnato tramite : Data:

Riferimento spedizione : Costo:

INFORMAZIONI RESTITUZIONE APPARECCHIO TEMPORANEO: compilata dal Centro Assistenza Autorizzato _____

Consegnato tramite : Data:

Riferimento Spedizione :

NOTA: Faxare queste info sulla spedizione solo quando avrai consegnato l'apparecchio temporaneo al corriere.



MEMO