

DISHWASHER

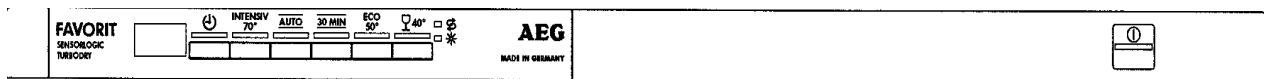

+ EDW 1503



Dishwasher



+
EDW 1503

© Electrolux
Muggenhofer Straße 135
D-90429 Nürnberg
Germany

Publ.-Nr.:
599 515 184
EN

Fax +49 (0)911 323 1022

Spares Operation

Ausgabe: 09.02
R.Kurzke

Index

1.	Control panel	3
2.	Dimensions	3
3.	Components	4
3.1	Electronic	4
3.2.	Circulation pump	4
3.3	Drain pump	4
3.4	Flow heater	4
3.5	Detergent dispenser	5
3.6	NTC-thermal sensor	6
3.7	Pressure switch	6
3.8	Interference filter	6
3.9	Spray arms	7
3.10	Drying fan	7
3.11	Regeneration dosing with condensor	8
3.11.1	Water softening/regeneration	8
4.	Repair informations	9
4.1	Open the housing	9
4.2	Position of the components	10 - 12
5.	Water course Scheme	13
5.1	All-Around Water Protection	14
5.2	Water intake	15
5.2.1	Water load steps	16 - 17
5.3	Draining	18 - 19
6.	Electronic	20
6.1	In- and Output Elements	20
6.2	General information	21
6.3	Input-philosophy: Program selection	22
6.4	Input-philosophy: Select start time	23
6.5	Input-philosophy: Program sequence	24
6.6	Input-philosophy: delete program	25
6.7.1	Input-philosophy: alter program	26
6.7.2	Input-philosophy: alter program	27
6.8	Input-philosophy: interrupt program	28
6.9	Input-philosophy: Displays	29
6.10	Overview of customer and aftersales service functions	30
6.11	Servicefunction / Adjust water hardness	31
6.12	Deactivation of rinse-aid addition	32
6.13	Deactivation of signal sound	33
6.14	fault memory and single actuator selection	34
6.15	LED test with integrated deletion of the fault memory	35
6.16	manufacturing test routine:	36
6.17	Overview of error displays	37
8.	Wirings	39
8.1	electric circuit diagram	39
8.2	Wiring diagramn	40

1. Control panel

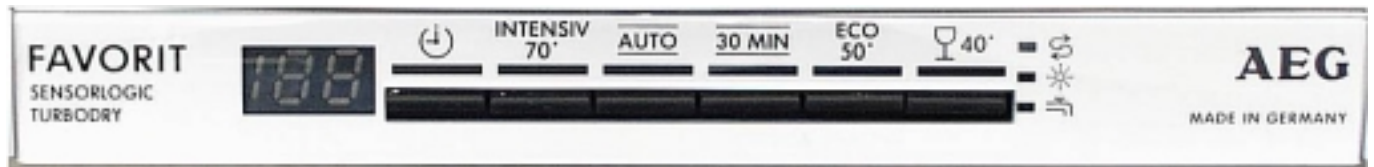

2. Dimensions

Build-in dimensions for Integrated Dishwashers

ÖKO-FAVORIT

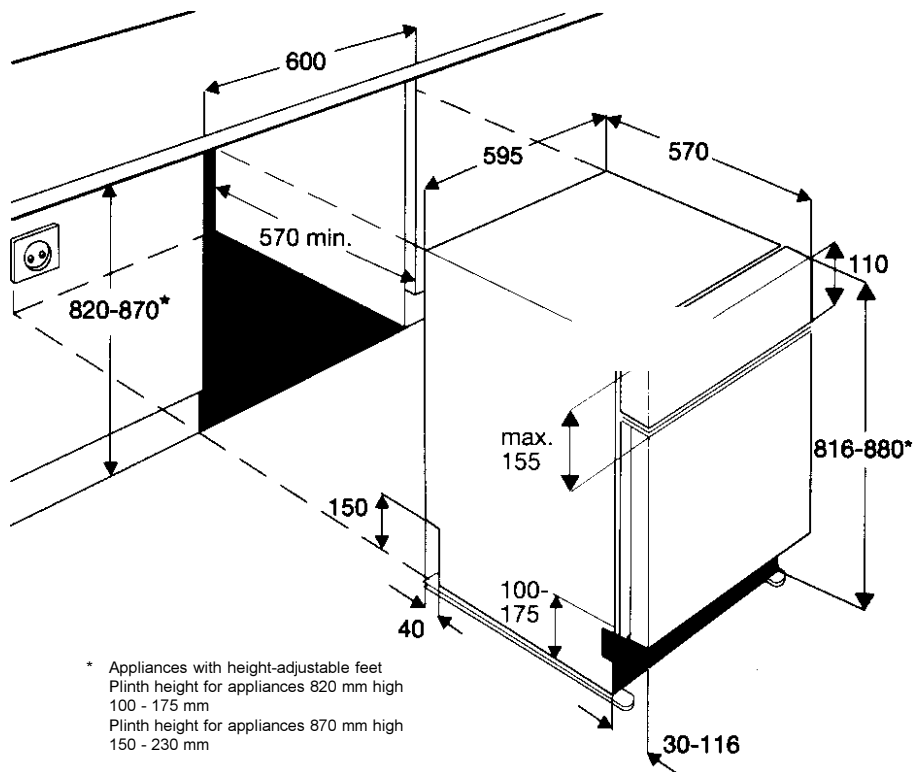

3. Components

3.1 Electronic

On electronic models, a micro processor controls all components, this is done using triacs. The electronic also memorizes all programme data.

The heating is switched by a relay on the electronic board.



3.2 Circulation Pump

The circulation pump is driven by an asynchronous motor with an auxiliary winding. The auxiliary winding is in circuit with a 3 mF capacitor. A tachogenerator is used for speed control. There are three speeds for rinsing. 2800 1/min, 2200 1/min, 1900 1/min, 1700 1/min, 1600 1/min, Power output 50 W.



Only for models with ceiling spray arm

3.3 Drain Pump

The drain pump is driven by a synchronous motor.

Power output 26 W.
Pump rate 15 l/min.



3.4 Flow Heater

The flow heater heats the water to the required temperature. During the wash cycle, water is constantly passing through the flow heater.

Power output	2000 W
Resistor	25 Ω
Protector	98 °C \pm 5 K
Thermal fuse	260 °C



3.5 Detergent dispenser

Dosing of detergent

prewash 10 ml
 wash 20 - 30 ml

Dosing of rinse aid

position 1 - 6 2 ml - 7 ml

Capacity

140 ml

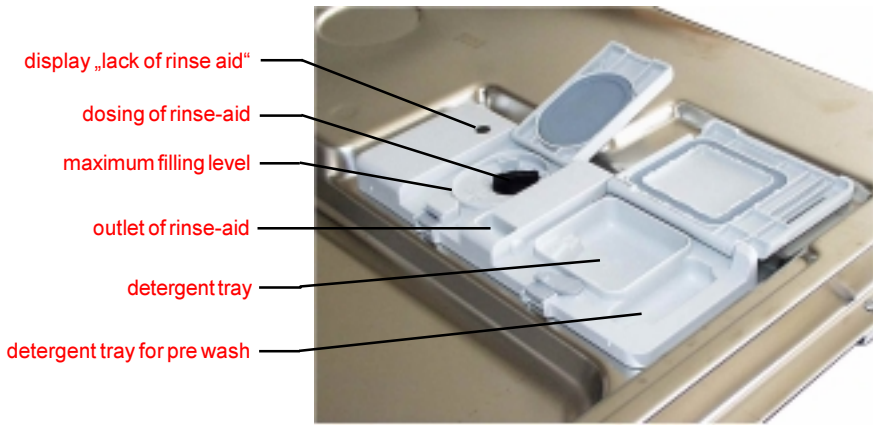

The detergent compartment 1 is filling corresponding to the set dosing quantity when the door is open. Possibly existing rinse-aid in compartments 2 and 3 flows back into the storage tank of the rinse-aid. The detergent trays are filled up. The door will be closed and the detergent for prewash will be rinsed out through the slots in the detergent dispenser cover.

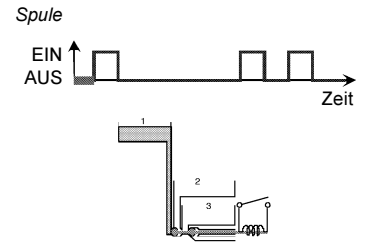

During the washing cycle the coil is switched on and the detergent compartment cover releases the detergent. The rinse-aid flows from compartment 1 into compartment 2.

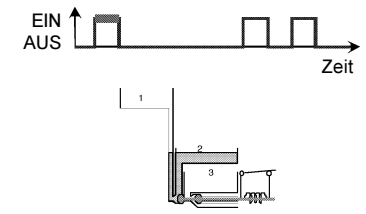

After switching off the coil, the rinse-aid flows from compartment 2 into compartment 3.

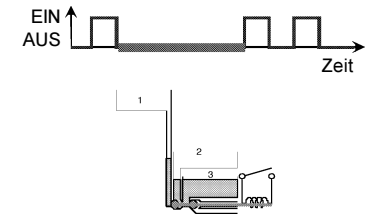

During the rinse cycle, the coil will be switched on when the rinse is warmed and the rinse-aid runs from compartment 3 into the rinse tank. At the same time, the remaining rinse-aid (15 %) runs from compartment 1 into compartment 2.

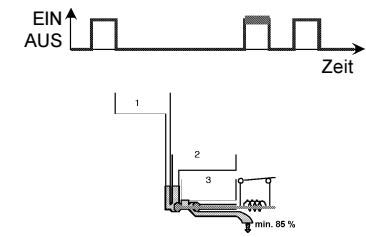

With the coil switched off, the rinse-aid flows from compartment 2 into compartment 3.

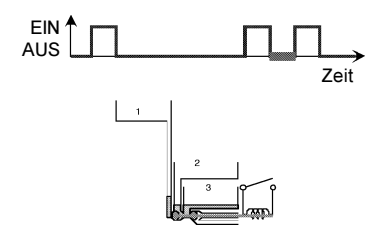

During the rinse cycle, the coil is always switched on twice. When it is switched on the second time, the remaining rinse-aid flows into the rinse tank.

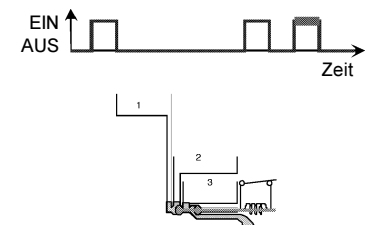

3.6 NTC-Temperature Sensor

Temp.	Resistor
10°C	9653 Ohm
25°C	4843 Ohm
60°C	1204 Ohm
90°C	445 Ohm



3.7 Pressure Switch

The pressure switch controls the water level.
Without water, contact 11 - 12 is closed.

fN Switch point with level 65 mm Ws
 Reset point with level 45 mm Ws

The pressure switch is not adjustable.

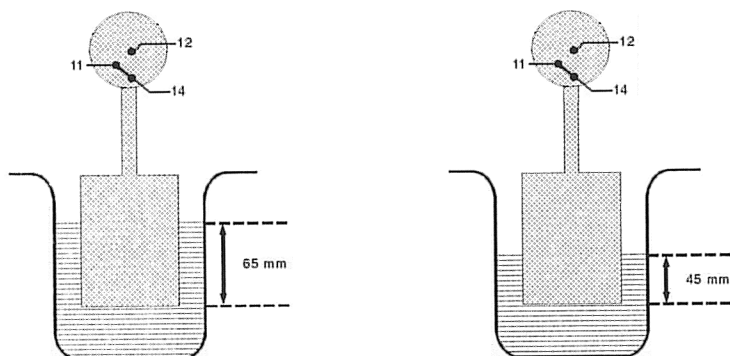

3.8 Interference Filter

The interference filter is connected in the terminal board parallel to the mains feed.

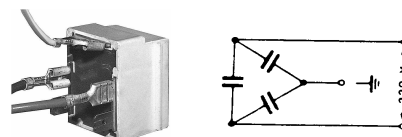

3.9 Spray arms

The new cutlery basket is placed at the upper dishwasher basket. The ceiling sprayarm sprays the water directly onto the cutlery basket and guarantees an excellent washing result with the cutlery placed in that basket.



Ceiling spray arm



upper spray arm



lower spray arm

3.10 Drying fan

The new drying fan is located at the top on the rinse tank.



Function mode of the condensing drying

Rinse tank, fan and regenerating dosing with condenser form a closed circuit. The humid air is sucked from the top of the rinse tank and blown through an air guide between rinse tank and regenerating dosing. Thereby the air gets dry and the condensate is guided to the drain tub.

The dry air gets through the rinse tank ventilation into the rinse tank. During the drying phase, the condenser is additionally cooled with 1 liter of water.

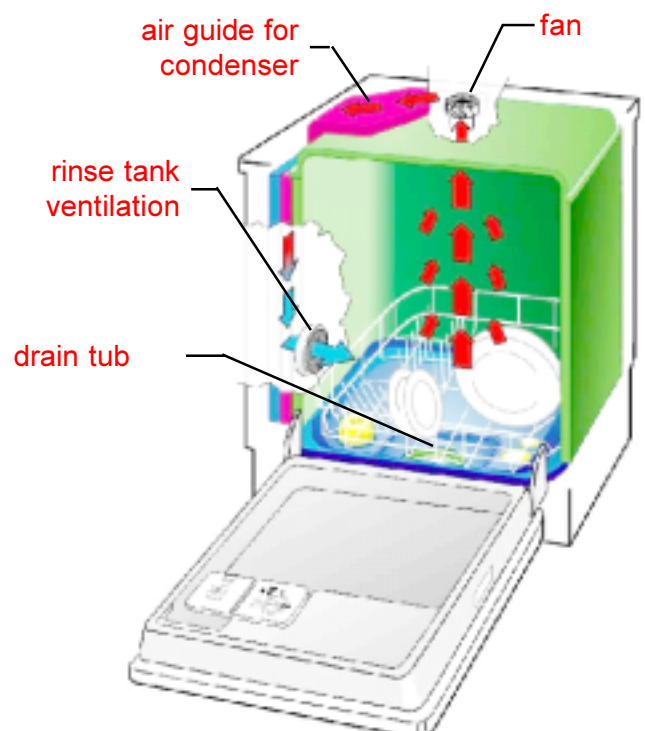

3.11 Regenerating dosing with condenser

With every filling step, the condenser cools down due to the cold incoming water. Therefore another 1 liter of water is required during the drying cycle.



1. softener unit
2. regeneration dosage chamber

3.11.1 Water softening/regeneration

The water softening can be adjusted in 10 levels. The incoming water flows until position 5 to 85 % through the softener which works according to the ion exchange principle. The ion exchanger is filled with small epoxy resin balls. The resins exchange the hardness constituents (calcium and magnesium), for sodium ions.

When all the sodium ions are used up, it is necessary to regenerate the softener. This is done by flushing a brine solution through the softener.

Afterwards the softener is washed out with fresh water and is now fully effective.

Depending on the water hardness, regeneration is only necessary after several wash cycles.

The remaining 15 % of water flow through the rinse tank ventilation directly into the appliance.

From setting of level 6, the whole water flows through the softener. For this purpose you also have to set mechanically from 0 to 1 with the regenerating dosing.

With the setting of level 9, it is additionally regenerated after the washing in a rinse cycle. With the settings 1 to 8, it is regenerated after the final rinse depending on need. The softening system is designed for a water hardness of up to 70 °dH.

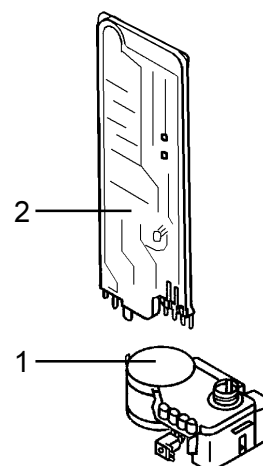
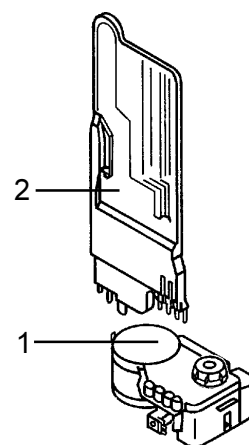

4. Service tips

4.1 Open the housing

To remove side panel remove fixing screws, pull the panel away from the rear, and gently out of the front trim. (pic.1).

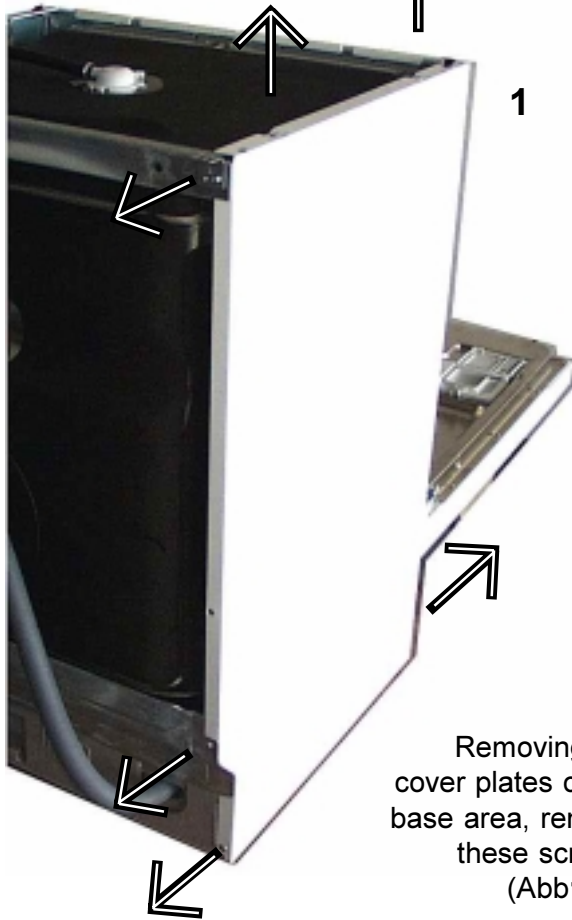

You need
Torx equipment



Remove the screws (1) to pull the outer door away.

To remove the panel, remove the fixing screws (2).

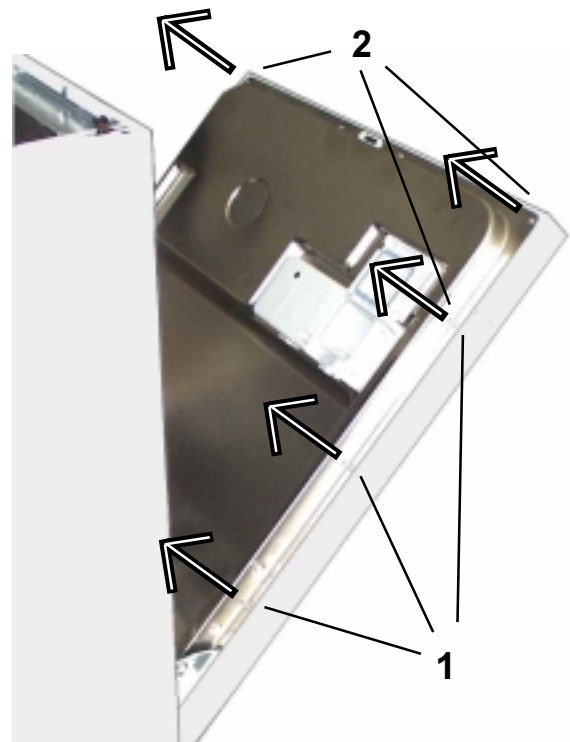

4.2 Position of Components

- Detergent dispenser (1)
- Spray arms (2)
- Roof-mounted shower (3)
- Salt container (4)
- Filter (5)

- Type plate (6)

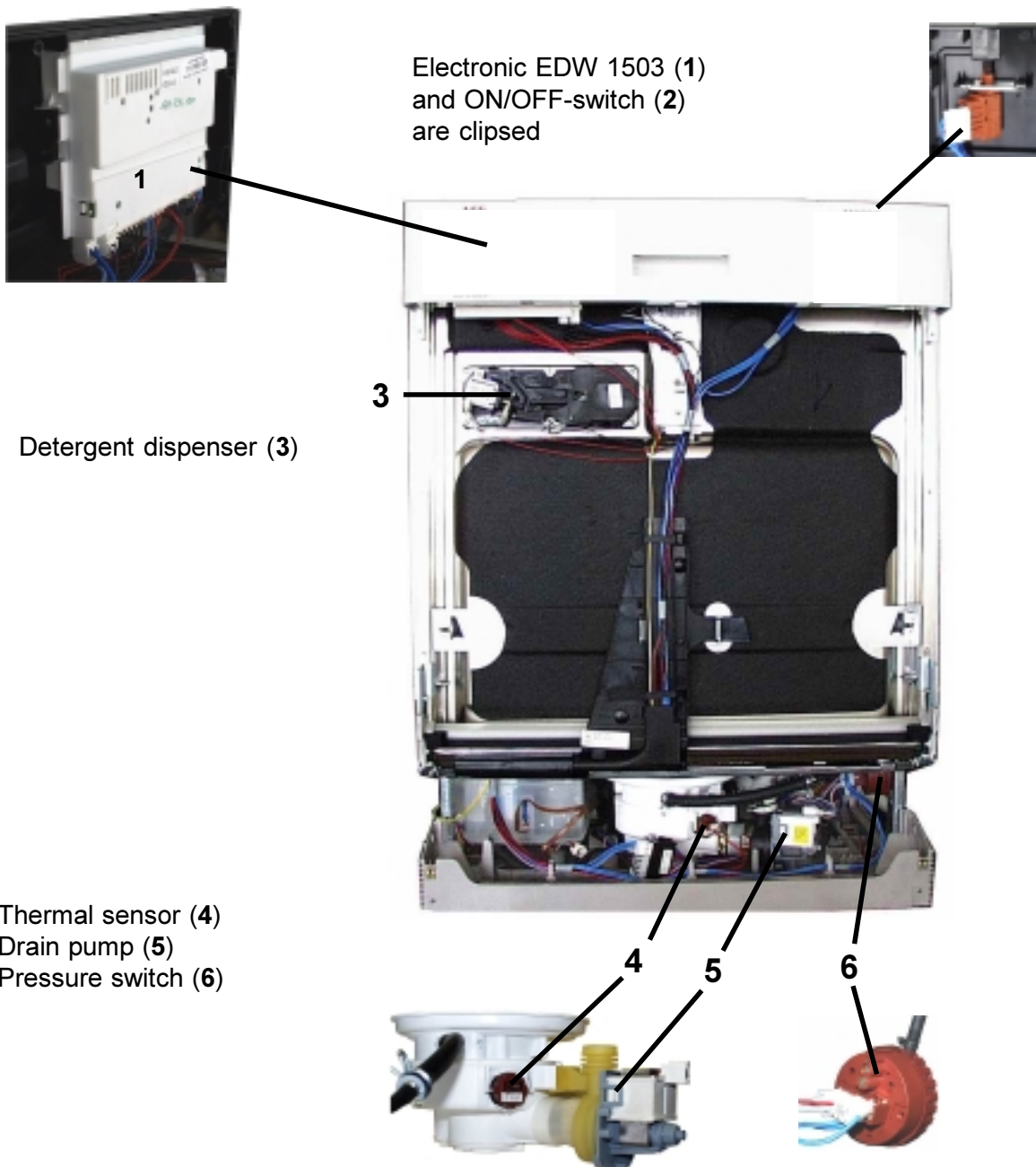
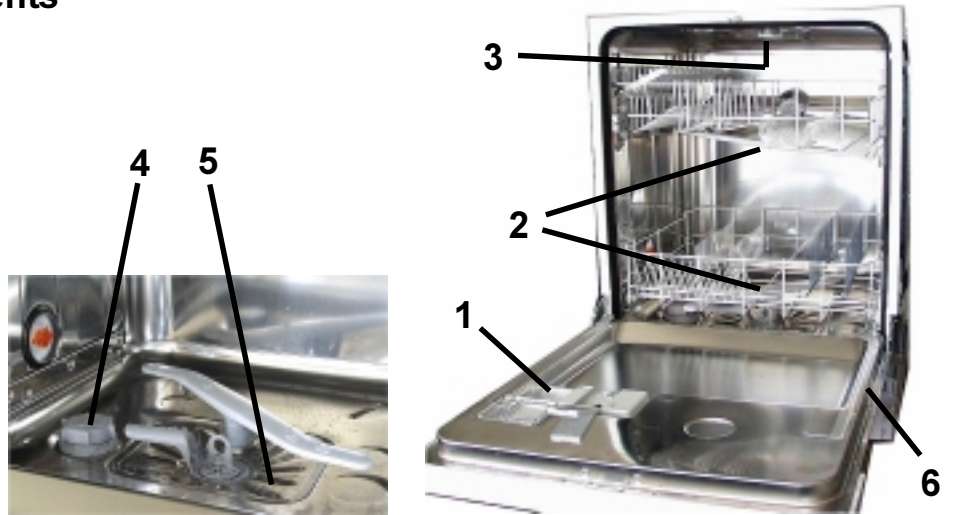

Back side view

- Flow heater (1)
- Terminal box (2)
- Inlet hose (3)
- Drain hose (4)
- Water inlet for above spray arm (5)

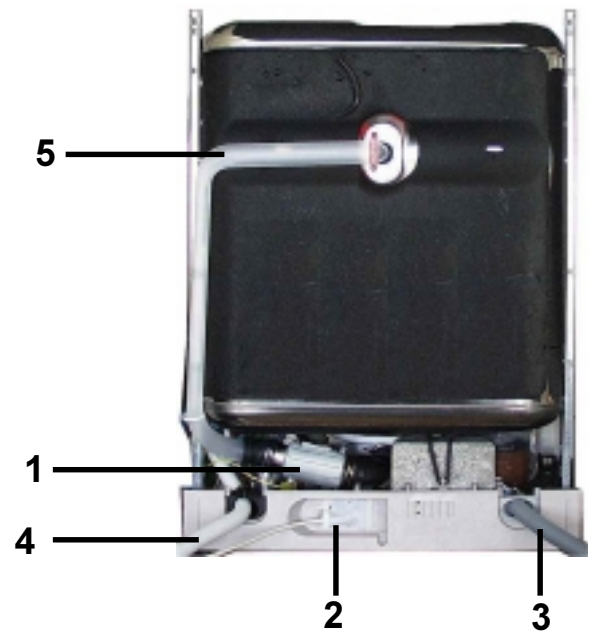

Removing the detergent dosage chamber:

- disengage locking tabs (1), disconnect hoses (2)
- holding the top of the chamber, pull upwards disengaging it from the softener.

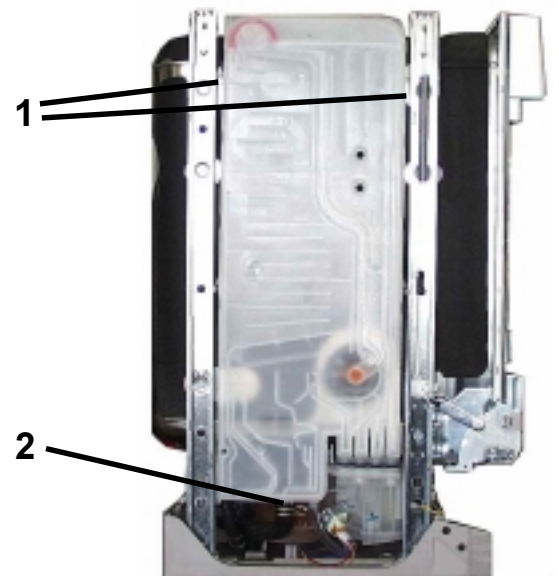

Removing the softener unit :

- remove the securing nut located under the salt cap.
- press softener (1) down and remove it through the front from the base area
- CAUTION if accessible release reed switch.

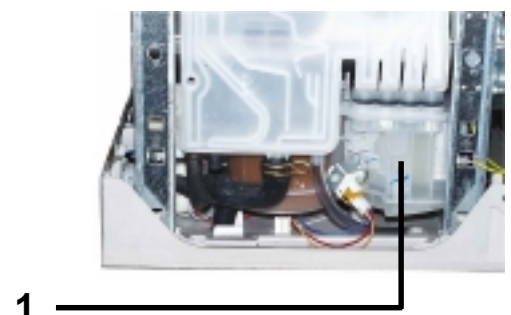

Removing the base :

- remove side panels, rear panel and plinth panel
- gently release base fixing clips with a screwdriver (figure)
- take off base carefully and release circulation pump, electronic and heater relay
- disconnect the float switch



With base removed, following components are accessible:

- Drain pump (1)
- Circulation pump (2)
- Flow heater (3)
- Temperature sensor / Turbidity sensor (4)
- Pressure switch (5)

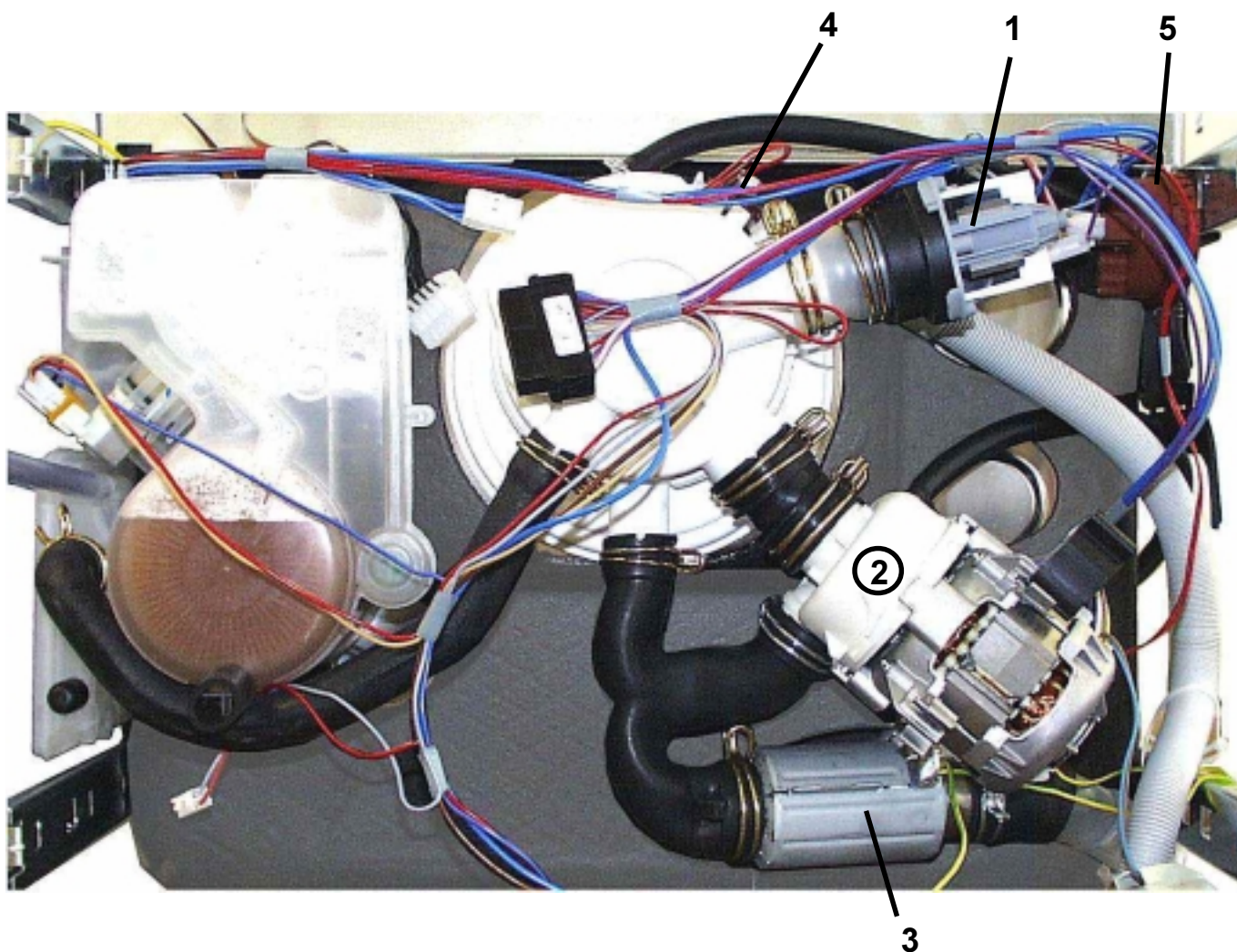

5. Water Course Scheme

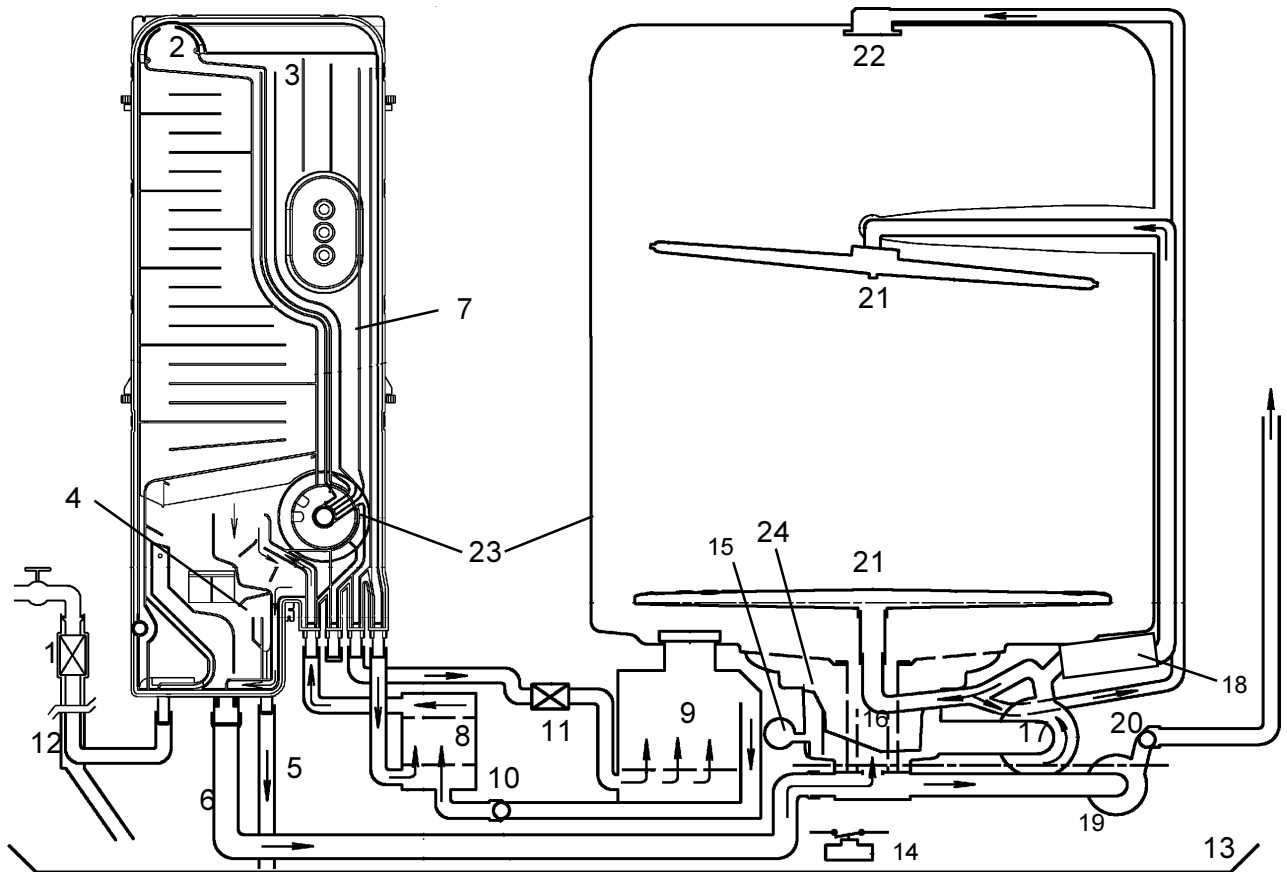

- | | | | | | |
|---|--|----|---------------------------------|----|---------------------|
| 1 | Inlet valve | 10 | Non-return valve salt container | 18 | Flow heater |
| 2 | Air break | 11 | Regeneration valve | 19 | Drain pump |
| 3 | Regeneration water dosage | 12 | Safety inlet hose | 20 | Non-return valve |
| 4 | Overflow safety level | 13 | Base tray | 21 | Spray arms |
| 5 | Safety overflow | 14 | Float switch | 22 | Roof-mounted shower |
| 6 | Inlet to sump from regeneration dosage chamber | 15 | Pressure switch | 23 | Tub vent |
| 7 | Regeneration dosage chamber | 16 | Filter | 24 | Sump assembly |
| 8 | Softener | 17 | Circulation pump | | |
| 9 | Salt container | | | | |

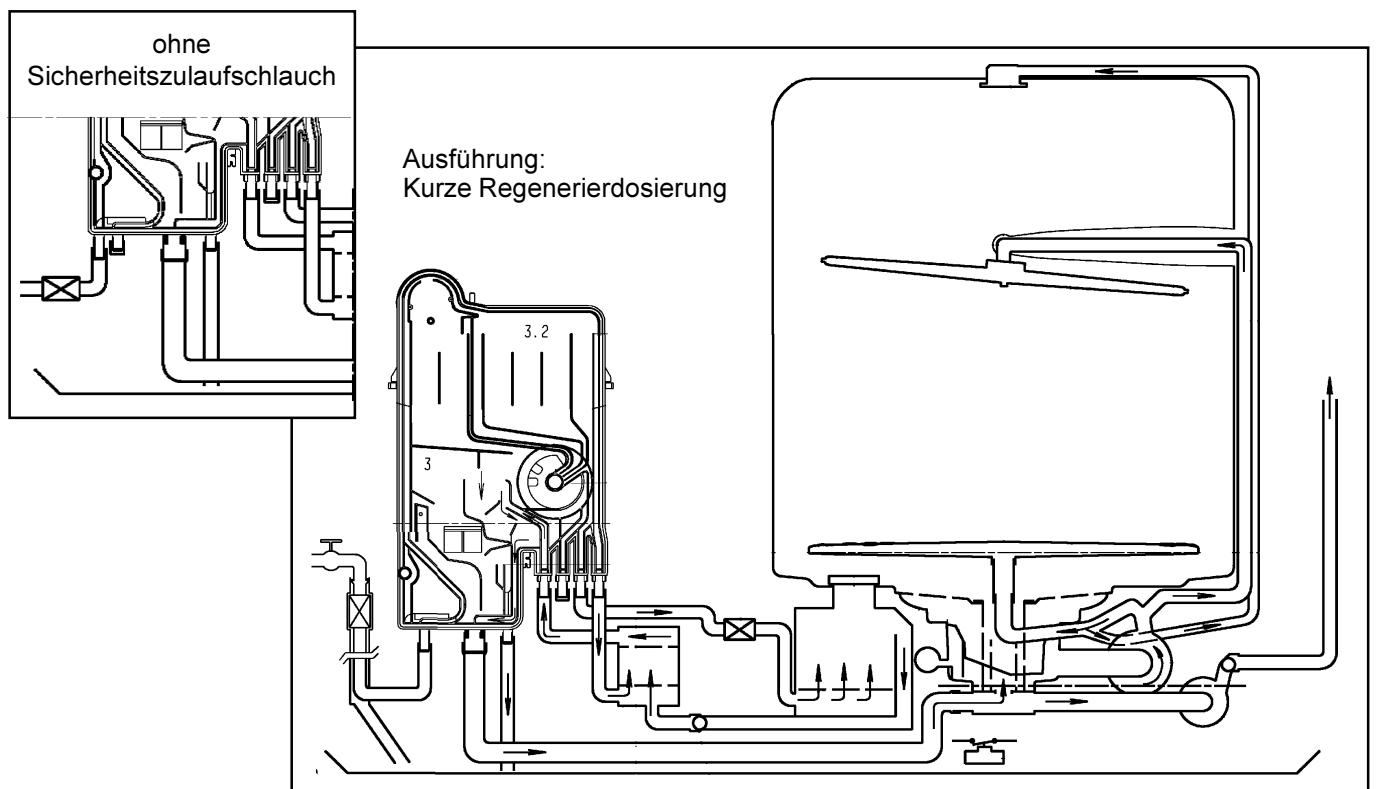

5.1 All-Around Water Protection

Aqua-Control Inlet Hose

The inlet hose has a double-wall construction. The inner hose is equipped with a flow restrictor built into the tap connection, and has a flow rate of 4 litres per minute. The inlet valve (1) is located in the base of the dishwasher. The safety outer hose (12) is connected to the regeneration chamber. If the inner hose should burst, the water passes into the tub. The safety pressure switch activates the drain pump and decreases the waterlevel down to „normal“ level. An additional overflow protection is a defined overflow through the regeneration chamber. The water flows into the bottom tray and activates the float switch, which energises the drain pump. This drains the dishwasher preventing water damage.

Safety level

If the safety level is reached by over-filling, the safety pressure switch starts the drain pump. The water is only drained until it has reached the normal level because the reset point of the safety pressure switch is above the switchpoint of the normal pressure switch.

Leakage Protection

The anti-flood switch in the base tray will activate the drain pump and drain the water from the tub in the event of an internal leakage. If the float switch is activated, all electric components are switched off except the electronic and the drain pump.

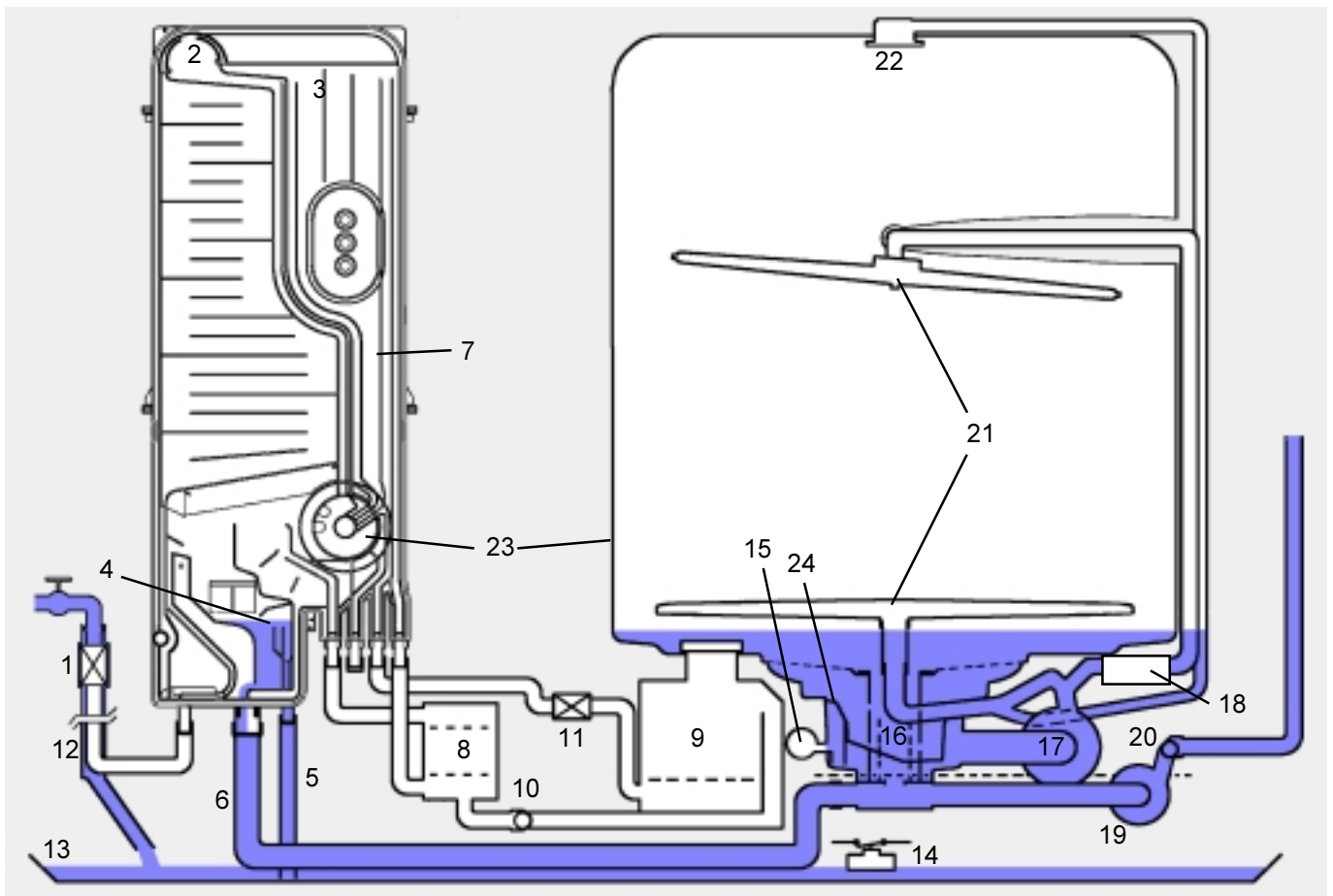

1	Inlet valve	10	Non-return valve salt container	18	Flow heater
2	Air break	11	Regeneration valve	19	Drain pump
3	Regeneration water dosage	12	Safety inlet hose	20	Non-return valve
4	Overflow safety level	13	Base tray	21	Spray arms
5	Safety overflow	14	Float switch	22	Roof-mounted shower
6	Inlet to sump from regeneration dosage chamber	15	Pressure switch	23	Tub vent
7	Regeneration dosage chamber	16	Filter	24	Sump assembly
8	Softener	17	Circulation pump		
9	Salt container				

5.2 Water Inlet

The water flows into the regeneration dosage chamber (7) via inlet valve (1), over air break (2), into regeneration dosage chambers (3) into softener (8). At this point the water divides. 1/4 of the water enters the tub through the vent (23). 3/4 of the water enters the sump (24) through hose (6).

The level control chamber built into the sump operates the pressure switch (15).

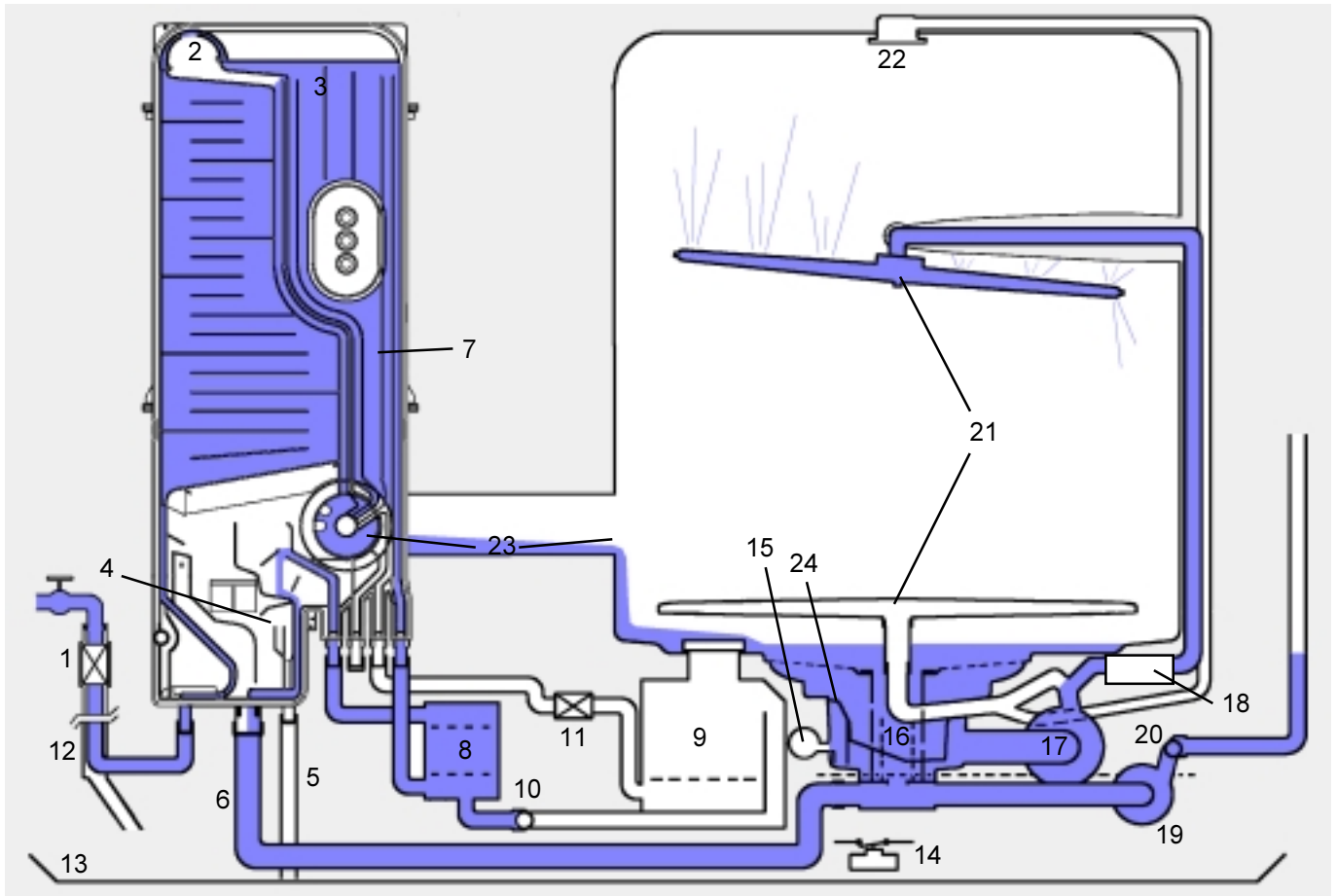

1	Inlet valve	10	Non-return valve salt container	18	Flow heater
2	Air break	11	Regeneration valve	19	Drain pump
3	Regeneration water dosage	12	Safety inlet hose	20	Non-return valve
4	Overflow safety level	13	Base tray	21	Spray arms
5	Safety overflow	14	Float switch	22	Roof-mounted shower
6	Inlet to sump from regeneration dosage chamber	15	Pressure switch	23	Tub vent
7	Regeneration dosage chamber	16	Filter	24	Sump assembly
8	Softener	17	Circulation pump		
9	Salt container				

5.2.1 Water load steps (Example)

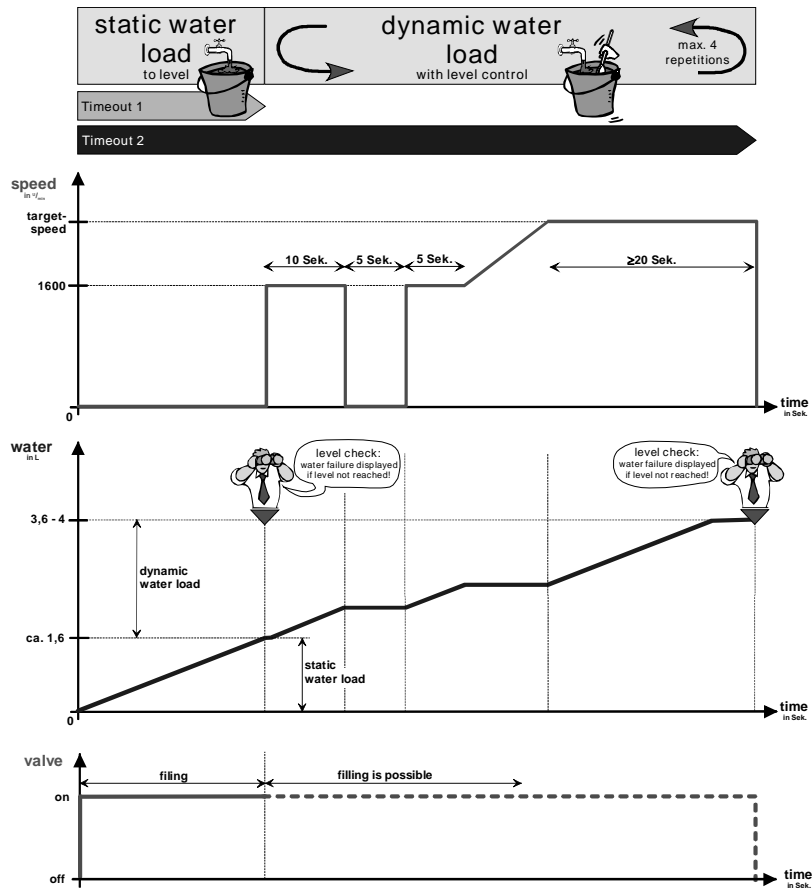

Static filling

- Static filling until pressure switch point.
failure code:
If this point isn't reached after max. 2 minutes (Timeout 1), a failure code is displayed and the program is stopped.

Dynamic filling

- 10 seconds filling at reduced circulation pump speed
- 5 seconds pause
- 10 seconds filling at reduced circulation pump speed
- filling with increasing circulation pump speed. As soon as the target speed has been reached, it is filled up to the pressure switch point.
Failure code:
If this dynamic switchpoint isn't reached within total 4 minutes (Timeout 2), the dynamic filling can be repeated 3 times. Only after non-successful repeating 3 times, a failure code is displayed and the program is stopped.

*) The target speed is dependent on the subsequent pulse wash.

pulse wash	pulse 2800 1/min	Pause 1600 1/min	target speed in dynamic filling
1	0,9 sec	4,5 sec	2200 1/min
2	0,6 sec	3 sec	1900 1/min
3	0,3 sec	1,5 sec	1700 1/min

New pulse wash with „random“ functionality

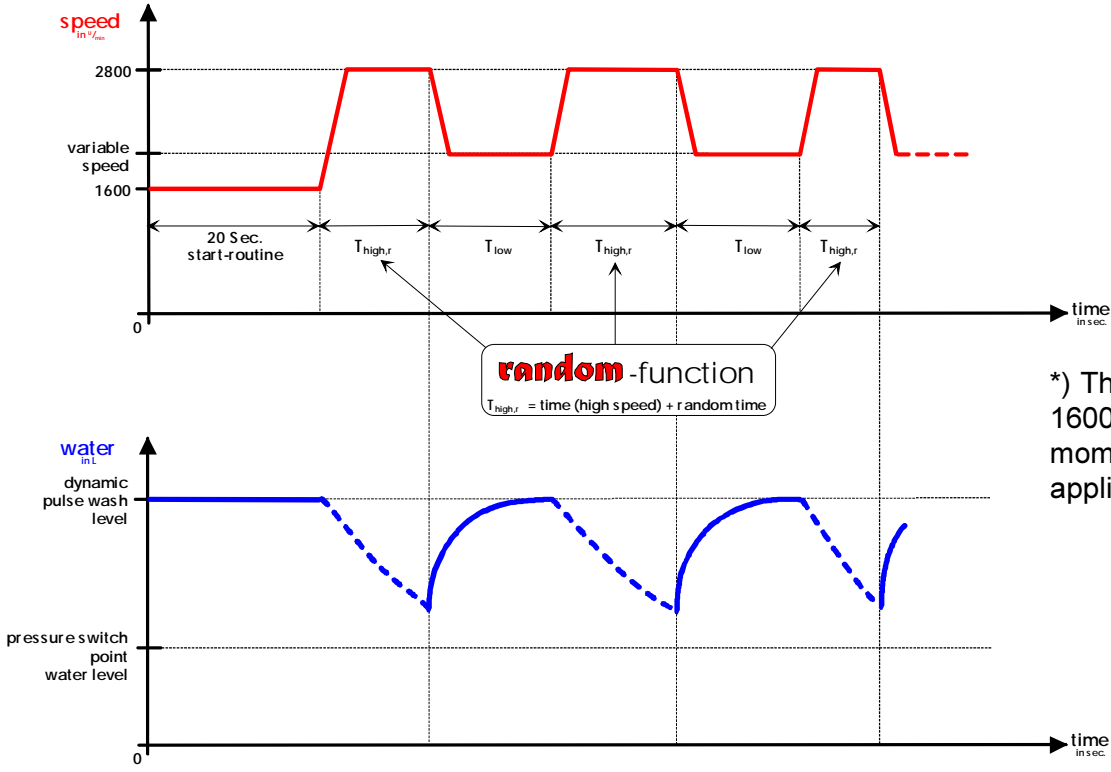

*) The variable speed is 1600 1/min at the moment and equal to all appliances.

Random-function

$$T_{high, r} = T_{high} + T_r$$

$$T_{low} = T_{high, r} + Ratio$$

- $T_{high, r}$ = time for high speed (calculated with random funktion)
- T_{high} = time for high speed (cycle definition)
- T_r = random time
- T_{low} = time for low speed
- Ratio = factor for low speed (eeprom definition)

Circulation

The circulation pump (17) pumps the water simultaneously into the ceiling shower (22) and into both spray arms (21). The water is filtered in the sieves (16) and led to the circulation pump.

Function of the new pulse wash with “random” functionality

After the filling steps, the circulation pump is running at two rotational speeds.

Pulse Wash	Pulse time 2800 1/min		Pause 1600 1/min		Use with Wash Cycles
	Definitive Time	+ Random Time	Definitive Time	+ Random Time	
1	0.9 sec	0 - 0.3 sec	4.5	0 - 1.5 sec	prewash intensive
					wash intensive
2	0.6 sec	0 - 0.3 sec	3	0 - 1.5 sec	wash and intermediate wash
					prewash normal
3	0.3 sec	0 - 0.3 sec	1.5	0 - 1.5 sec	rinse

The ratio of pulse time and pause is always 1 : 5.

5.3 Draining

During the wash cycle the water is pumped out at various stages. First the draining water cleans the filters (16). The filters are open at the bottom which allows any soilage to be rinsed off sufficiently. There is a non-return valve (20) at the inlet connection to the drain pump (19). This valve prevents the water

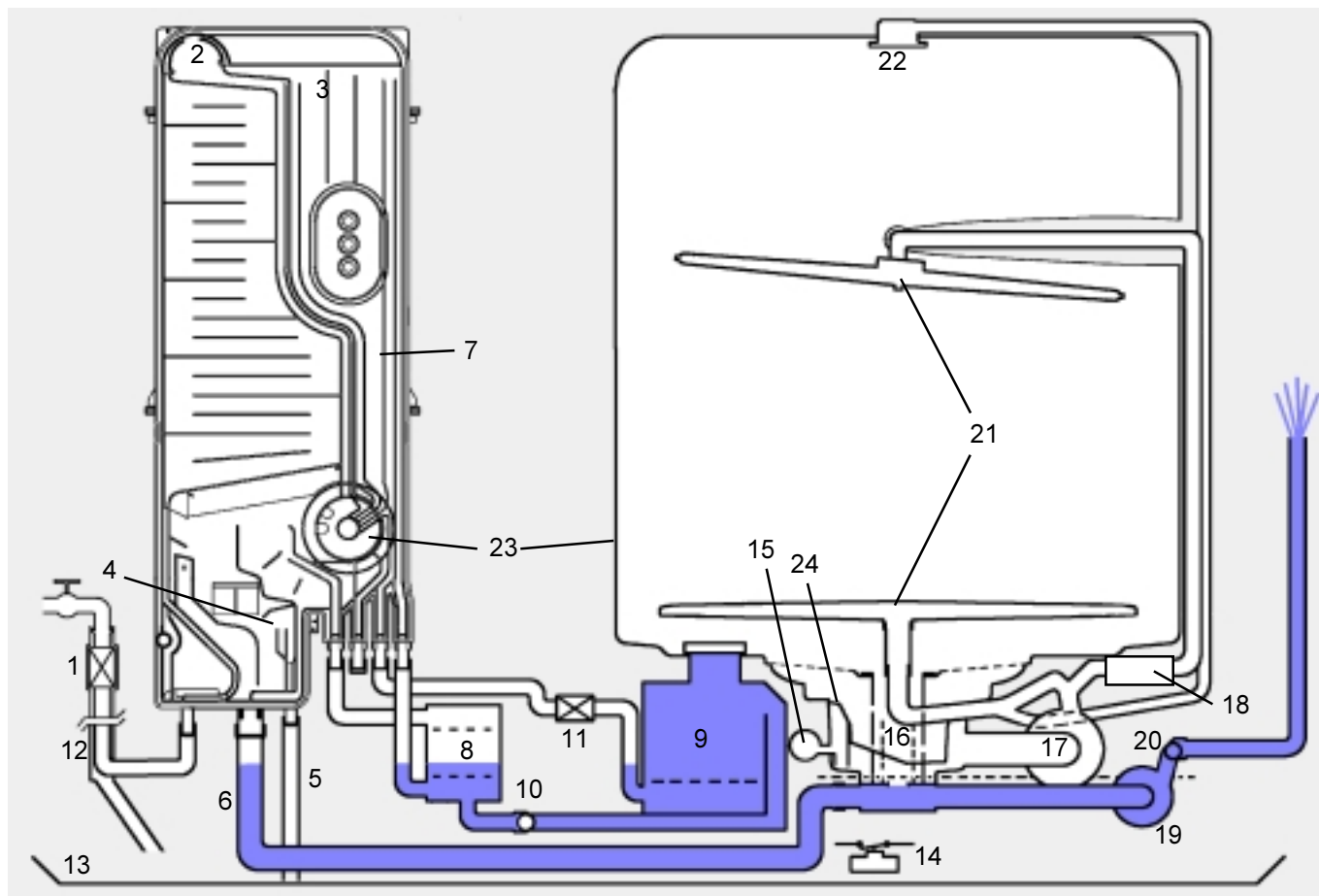

1	Inlet valve	10	Non-return valve salt container	18	Flow heater
2	Air break	11	Regeneration valve	19	Drain pump
3	Regeneration water dosage	12	Safety inlet hose	20	Non-return valve
4	Overflow safety level	13	Base tray	21	Spray arms
5	Safety overflow	14	Float switch	22	Roof-mounted shower
6	Inlet to sump from regeneration dosage chamber	15	Pressure switch	23	Tub vent
7	Regeneration dosage chamber	16	Filter	24	Sump assembly
8	Softener	17	Circulation pump		
9	Salt container				

Sequence draining with pressure switch level check

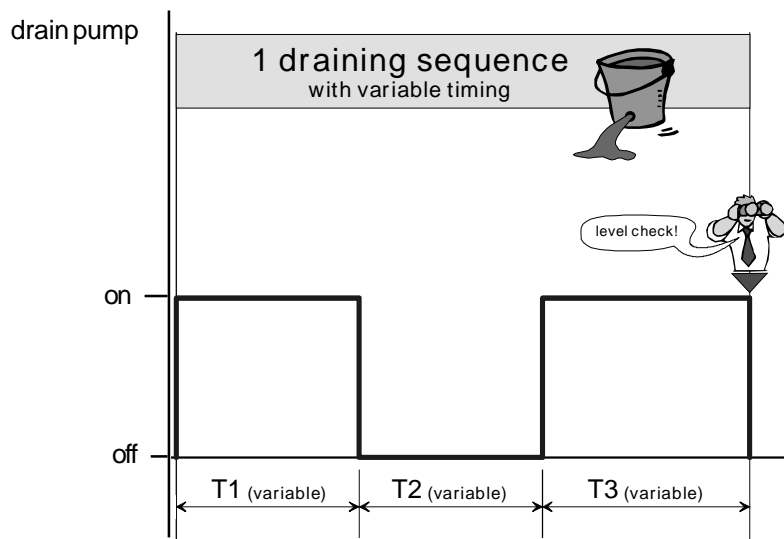

Drain Cycle	T1	T2	T3
First draining before every wash cycle	45 sec	15 sec	20 sec
Draining after the wash cycles	30 sec	20 sec	10 sec

New draining with sequence draining

- The draining step contains of 3 time sequences.
In the middle sequence, during time T2 the drain pump is stopped.
- At the end of the drain step, the water level is checked.
- If the switch back is reached, the drain step is terminated.
If the switch back isn't reached, the drain step is repeated.
- A failure code is displayed, if after 2 drain steps, the switch back couldn't be reached.
In this case, the program is stopped.

6. Electronic EDW 1503

6.1 In- and output elements

- EDW1503

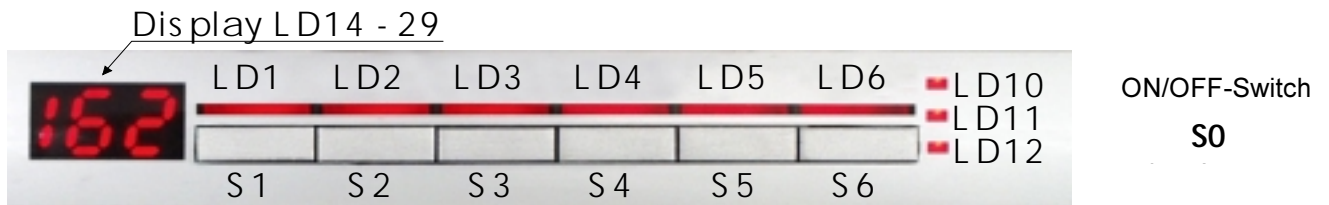

6.2. General information

- **Equipment in the panel area**

(see description page B 1)

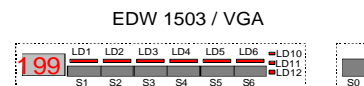

- **Possible equipment**

- ♦ Separate ON/OFF switch S0 without optical confirmation
 - ♦ 6 keys S1 to S6 to select programs or options with the corresponding LEDs
 - All keys are free and can be programmed without any restriction by the programming of the appliance variant.
 - ♦ 2.5-digit display and 3 LEDs (LD10 TO LD12)

- **⚠ Absolutely necessary minimum equipment:**

Keys S0 (ON/OFF) and the first 3 keys S1 to S3 with the corresponding LEDs and display. The keys S1 to S3 are absolutely necessary to select all customer respectively service functions, such as setting of hardness!

- **Variant-dependent existing equipment:**

- ♦ Indication of start time by 2.5-digit display
 - Indication between 1 and 19 hours (in steps of 1h)
 - ♦ Indication of remaining run time by 2.5-digit display
 - indication of maximum run time "199"
 - ♦ LED display for salt
 - ♦ LED display for rinse-aid
 - ♦ LED display for water tap closed
 - ♦ LED display for END

- **Functions which can be adjusted variably by the customer via the control panel:**

(see description page B 11-13)

- ♦ Indication and alteration of water hardness by display and acoustic output.
 - ♦ Activation/deactivation of rinse-aid addition. Indication by display.
 - ♦ Activation/deactivation of signal sound for end. Indication by display.

- **Miscellaneous:**

- ♦ regeneration depending on need
 - ♦ manufacturing test routine
 - ♦ various service functions (fault memory, single actuator selection ...)
 - ♦ design of appliance for max. energy label AAA
 - ♦ alternatively with or without fan drying
 - ♦ aqua control system in different versions
 - depending on electr. and mech. components and the corresponding variant programming

- **Possible selectable program options:**

- ♦ start-time preselection
 - ♦ half load "small quantity" as automatic system or with key
 - ♦ additional washing cycle
 - ♦ 3 in 1 (special tablet program)
 - ♦ sanitize

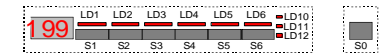

6.3. Input philosophy: program selection

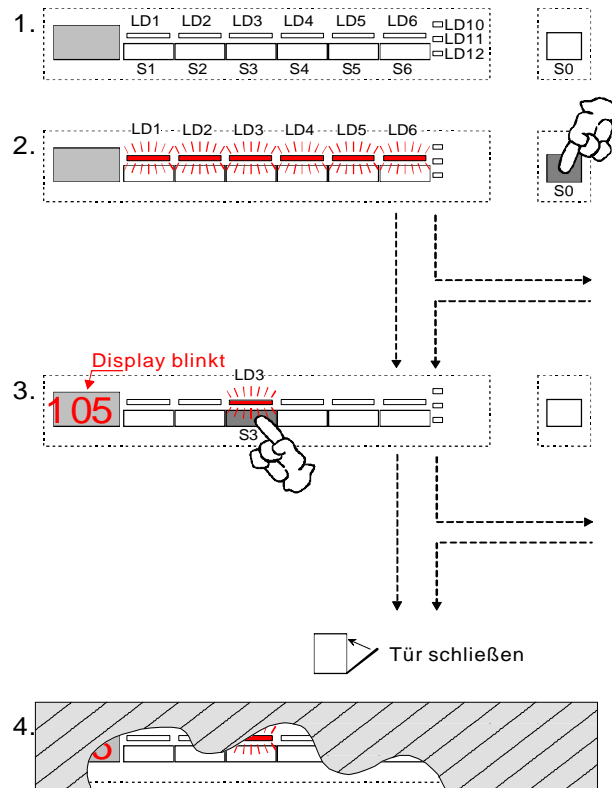

1. Appliance in switched-off condition

2. Switch on appliance with ON/OFF key S0 -- "prestart" mode

↪ Appliance is in the prestart mode

↪ All LEDs of the program keys and the "SZV" (start-time preselection) key are lit, the keys can be selected

Selection of a start time possible

(see description page B 4 / "Input philosophy start-time preselection")

3. Select program by pressing the corresponding key.

↪ Corresponding program LED is lit, run time to be expected is flashing.

Within 3 seconds it is possible to alter or additionally select an option.

Selection of a start time possible

(see description page B 4 / "Input philosophy start-time preselection")

4. Program starts only when the door has been closed.

Up to this moment it is possible to alter or additionally select an option at any time.

When the door has been closed, the program starts automatically.

↪ Corresponding program LED is lit.

↪ Run time is indicated.

6.4. Input philosophy: select start time

Variant A time preselection after program selection

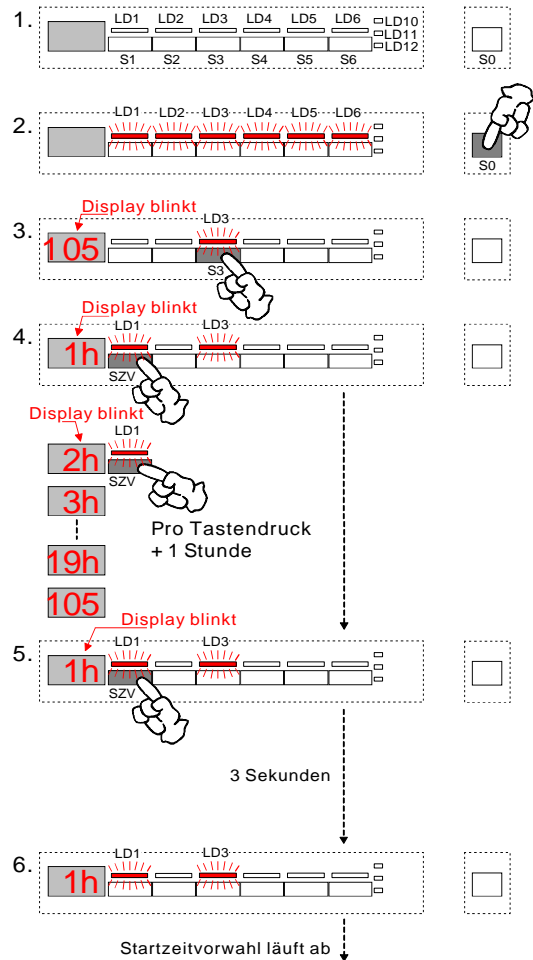

Variant A

- Appliance in switched-off condition
- Switch on appliance with ON/OFF key S₀
 - Appliance in "prestart" mode
 - All LEDs of program and option keys are lit, the keys can be selected.
- Select program by pressing the corresponding key.
 - Corresponding program LED is lit
 - Run time to be expected is flashing
- Actuate start-time preselection key within 3 seconds
 - The keys of program and "SZV" are lit
 - Adjusted start time is flashing
- Any additional key pressure causes the start time scrolling by 1 hour
 1h - 2h - ... - 19h - display remaining run time (SZV=0h) - 1h - 2h - ...
- 3 seconds after the last actuation of any key, the adjusted start time gets active and runs down after the door has been closed.
 - LEDs of program, "SZV" and start time are lit in the display

Variant B →

- like variant A
- Actuate start-time preselection key.
 - "SZV" LED is lit
 - adjusted start time is flashing
- Any additional key pressure causes the start time scrolling by 1 hour
 1h - 2h - 3h - ... - 19h - display off (SZV=0h) - 1h - 2h - ...
 (With the setting 0h all LEDs of program and option keys are lit)
- Indication of "SZV" is flashing in the display until a washing cycle will be selected additionally. The selected start time is not active!
- Select program by pressing the corresponding key.
 - LEDs of program and "SZV" are lit
 - Run time to be expected is flashing
- 3 seconds after the last actuation of any key the adjusted start time gets active and runs down after the door has been closed.
 - LEDs of program, "SZV" and start time are lit in the display

Variant B time preselection before program selection

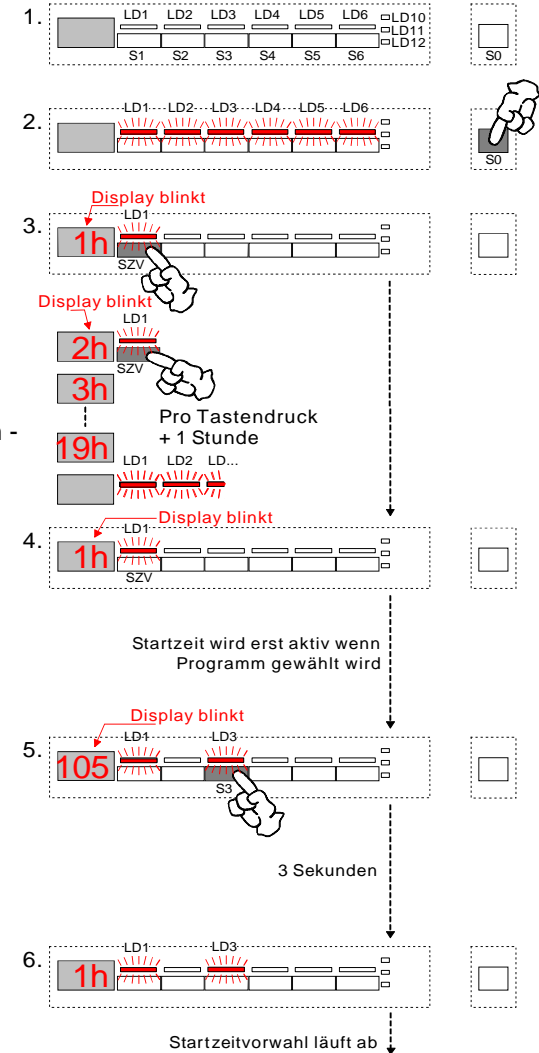

6.5. Input philosophy: program run

- ⚠ A special feature with fully integrated appliances is the condition that there are no control and display elements visible when the door has been closed.
That is why important information for the customer, such as the cycle end or information on faults are indicated acoustically in addition.
This results in a few differences for the start, run and end of a cycle in comparison with normal upright, substructure resp. integrated variants of appliances.

• Cycle start

- ♦ The cycle starts finally when the door has been closed!
- ♦ After the door has been closed and the cycle has started successfully it is no more possible to make any alterations etc.
But to make changes in the program setting in exceptional cases, you have to open the door during the running cycle.
 - ☞ *cancel resp. delete cycle*
(see description page B 6 / "Delete cycle")
 - ☞ *change resp. alter cycle*
(see description page B 7.2 / "Reselect cycle")

• Cycle run

- ⚠ As already described above there are no displays visible with VGA appliances caused by the type of construction. The optical displays are selected but not hidden by the worktop.
 - ♦ The LEDs of the selected washing cycle are lit during the whole cycle run.
 - ♦ The display indicates the still remaining washing time in minutes.
The run time is updated depending on the program.
The update is executed in changes of program parts. In doing so the run time can correct in jumps downward, or the display is stopped until the time will be synchronized again.

• Cycle end

- ⚠ As already described above there are no displays visible with VGA appliances caused by the type of construction. The optical displays are selected but hidden by the worktop.
 - ♦ When the cycle has ended, an acoustic signal will sound.
The acoustic end signal is a whistling sound with the following interval:
15 seconds on - 3 minutes off - 15 seconds on - 3 minutes off - 15 seconds on - completely off
The end signal is cleared immediately by opening the door.
 - ♦ The confirmation LED of the program key of the run-down cycle is lit and the display indicates "0". These displays, however, are immediately deleted when opening the door.
 - ♦ When the cycle end has been reached, it is possible to delete the run-down cycle by opening the door. After closing the door, the appliance is automatically again in the "prestart" mode, i.e. a new program could be selected again at once.
 - ♦ In order to switch off the appliance completely, you have to actuate the ON/OFF key S0.
Even in this case, the run-down cycle is deleted. All displays go out.

6.6. Input philosophy: delete program

EDW 1503 / VGA

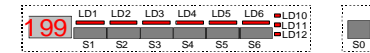

A selected or already started washing cycle can be deleted at any time during normal operation

• Delete program (using the reset function)

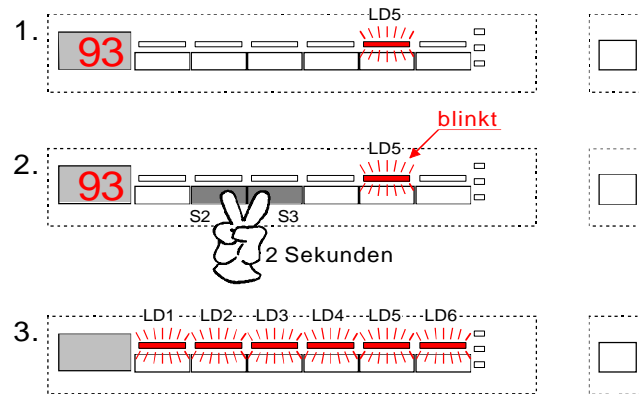

⚠ Reset function always with keys S2 and S3

1. Cycle running
2. Actuate reset keys S2 and S3 for about 2 seconds
 - ↳ LED of the running cycle starts flashing
 - ↳ The run time continues to be indicated.
3. After about 2 seconds all LEDs of program and option keys are lit. The program is deleted. The appliance is in the "prestart" mode.

6.7.1. Input philosophy: alter program

EDW 1503 / VGA

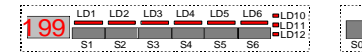

- Alter program during the prestart mode

The door is still open at that moment!

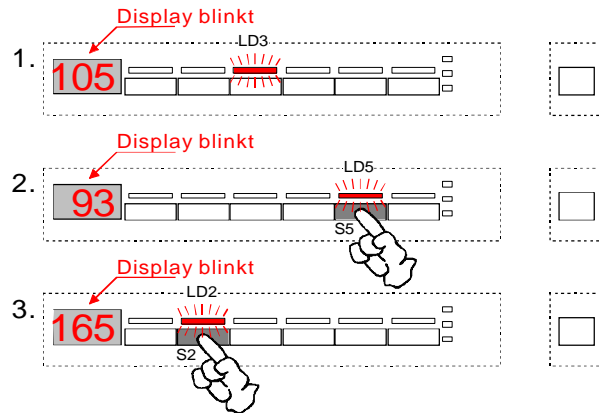

- Program has been selected but did not yet start
 - ↪ Corresponding program LED is lit.
 - ↪ Presumable run time is flashing in the display.
- By pressing the new desired program key shortly it is possible to alter directly. Options already selected before are cleared and have to be selected anew.
 - ↪ New selected program LED is lit.
 - ↪ Presumable new run time is flashing in the display.
- Before the door has been closed it can be altered as many times as one wants.

Only when the door has been closed, the program will start automatically.

Special feature when a start time was selected before!

- Program and start time have been selected but did not yet start.
 - ↪ LEDs of program and "SZV" are lit.
 - ↪ Programmed start time is flashing in the display.
- By pressing the new desired program key shortly it is possible to alter directly. The start-time preselection already selected is preserved after the alteration! Program options already selected before, however, are deleted and must be selected anew.
 - ↪ New program LED and "SZV" LED are lit.
 - ↪ Run time to be expected is flashing in the display for 2 sec., afterwards the start time is flashing again.

If the selected start time is already running down (the time is permanently lit in the display) you have to press the new desired program key a longer time (about 6 seconds) for alteration.

6.7.2. Input philosophy: alter program

EDW 1503 / VGA

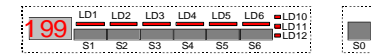

• Alter program after program start

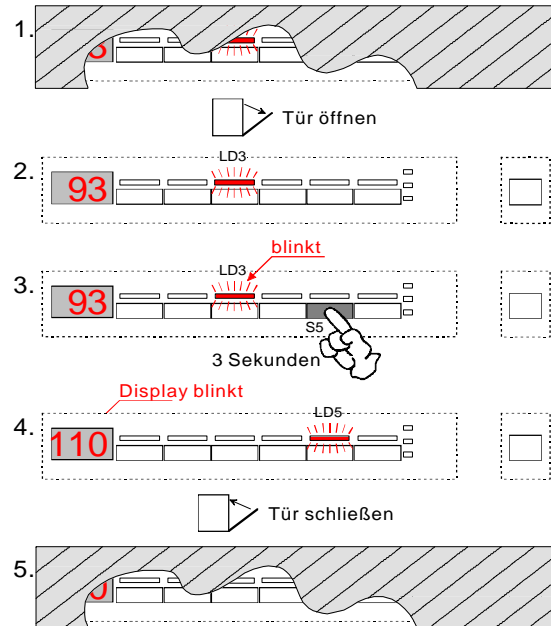

1. To alter a program you have to open the door!
2. Program is stopped by opening the door.
 - ↪ Corresponding program LED is lit.
 - ↪ Run time is indicated in the display.
3. Actuate key of the new desired program (in our example S5) for about 6 seconds.
 - ↪ Display LED of running program starts flashing.
 - ↪ Run time is indicated in the display.
4. After this time the previous program LED and the program LED of the new desired program is lit.
 - ↪ The display indicates the run time which is to be expected anew flashing.
5. The cycle will start automatically when the door has been closed.

⚠ If a program is altered after an already started cycle the new cycle starts generally from the beginning! This is also indicated by the run time in the display.
Options already selected before will be deleted and must be selected anew.

6.8. Input philosophy: interrupt program

• Interrupt program

- ♦ Using the ON/OFF key S0 it is possible to interrupt the program as long as one wants. The same is valid for an interruption by opening the door.
- ♦ There is no deleting function integrated in the ON/OFF key S0.
- ♦ If the cycle is interrupted by using the ON/OFF key, all displays go out.
- ♦ The cycle run is continued by switching on using the ON/OFF key S0 resp. by closing the door, without that another key actuation becomes necessary. Information: The cycle is continued with a short time delay.
- ♦ All displays and confirmations appear in the same condition as before the interruption.

• What happens when opening and closing the door?

- ♦ **The appliance is switched on and in the "prestart" mode**
 - ♦ After opening the door all indications keep to be displayed on the panel. The power supply of the electronic is fully guaranteed as long as the appliance remains switched on.
- ♦ **The door is opened during the running cycle**
 - ♦ After opening the door all indications keep to be displayed on the panel, as long as the appliance keeps to be switched on by using the ON/OFF key S0.
 - ♦ After closing the door the appliance will start automatically and the cycle run will be continued.

Attention:

- ♦ When the 1. regeneration has been reached in the program part "drying" it is valid:
 - ♦ When the door is open longer than 30 seconds, the program will be deleted. When the door has been closed, the appliance will be automatically again in the "prestart" mode. A new program could be selected again immediately.
 - ♦ Switching off the appliance by pressing the ON/OFF key S0 also deletes the current program from that moment.(see description page B 3 / "Input philosophy program selection")

• What happens in case of resp. after a power failure?

- ♦ In case of a power failure the appliance behaves as when switched off using the ON/OFF key.
(see description above / under "Interrupt program")
- ♦ After the mains have returned the appliance behaves as after being switched on using the ON/OFF key S0.
- ♦ After a power failure the cycle continues without any necessary key actuations.

6.9. Input philosophy - displays

All displays are designed as LED displays and are available depending on the appliance variant. Start-time preselection and run time are indicated via a display only with the EDW1503.

 A special feature with fully integrated appliances is the condition that there are no control and display elements visible when the door has been closed.

• Displays for program selection and options

- ↪ Above resp. next to a program or option key there is generally a corresponding LED to confirm the selected function.
- ↪ They are lit permanently during the whole cycle run.

• Display for start-time preselection (SZV)

- ↪ The start-time preselection is indicated via a 2.5-digit display.
- ↪ The display indicates the start time in hours.
- ↪ The start time is counted down to 0h in steps of hours.
- ↪ The start-time setting is displayed scrolling.
1h - 2h - 3h - ... - 19h - 0h (SZV off) - 1h - 2h - ...
- ↪ When the start-time preselection has run down, the display indicates the run time to be expected of the selected washing cycle in minutes.

• Run time display (RLA)

- ↪ The remaining run time is indicated via a 2.5-digit display.
- ↪ The display indicates the still remaining washing time in minutes.
- ↪ The run time is updated depending on the program. The update is executed in changes of program parts. In doing so the start time can correct downward in jumps, or the display is stopped until the time is synchronized again.

• Information displays

- ↪ The LED position is depending on the programming of the variant.
They can be programmed to any LED which is not programmed with a program or option key.
- ↪ The LEDs are lit permanently from switching on the appliance by ON/OFF key S0, until the moment of the started program. Furthermore, the LEDs are lit when the cycle end has been reached until the appliance is switched off.
- ↪ The information LEDs go out during the whole cycle run!

♦ LED display "salt"

- ↪ LED is lit in case of a lack of salt
- ↪ LED goes out when salt has been refilled
(Depending on the salt dissolution it can take some time until the LED goes out)
Information: LED display "salt" goes out with hardness setting 1
(no regeneration necessary - indication in the display "1L")

♦ LED display "rinse-aid"

- ↪ LED is lit in case of a lack of rinse-aid
- ↪ LED goes out after rinse-aid has been refilled
Information: The rinse-aid addition can be deactivated completely by the customer.
This also deactivates the LED display "rinse-aid".
(see description page B 12 / "Deactivation of rinse-aid addition")

 If the option "3 in 1" is selected (special tablet option) neither the "salt" LED nor the "rinse-aid" LED is selected.

♦ LED display "water"

- ↪ LED is lit when there is no or too less water filling into the appliance.
A reason for that could be, for example, a closed water tap.
- ↪ The program is stopped and can be continued when the fault has been eliminated by actuating the program key.
(see also description page B 19 / "Survey of fault displays - fault 10")

6.10. Short survey of all customer, service and aftersales service functions

EDW 1503 / VGA

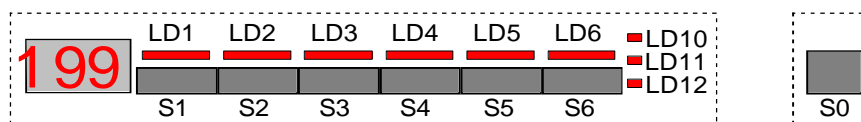

Who?	Which function?	Selection of special mode customer or service	Confirmation of the special mode	Call of special function	Detailed description
Custo	setting of water hardness	→ switch on appliance with ON/OFF <u>S0</u> →	simultaneously and keep them pressed until ...	→ keys <u>S1</u> - <u>S3</u> are flashing →	press key <u>S1</u> see page B 11
	deactivation rinse-aid addition	→		→	press key <u>S2</u> see page B 12
	deactivation signal sound	→	 Bei Aufruf der Kunden-Funktionen darf generell kein Spülprogramm gewählt sein!		→ press key <u>S3</u> see page B 13
manu factur ing /	readout of fault memory single actuator selection	→	press keys <u>S1</u> and <u>S2</u> simultaneously and switch on appliance with ON/OFF <u>S0</u> keep keys <u>S1</u> and <u>S2</u> pressed for	→ ... LEDs of keys <u>S1</u> - <u>S3</u> are flashing →	press key <u>S1</u> see page B 14
	LED test with integrated deletion of fault memory	→		→	press key <u>S2</u> see page B 15
	manufacturing test routine	→		→	press key <u>S3</u> see page B 16
	deactivation Pulse Wash	→		→	press keys <u>S2</u> + <u>S3</u> see page B 17
	additional washing cycle	→		→	press keys <u>S1</u> + <u>S2</u> see page B 18

6.11. Service function / setting of water hardness

General information

- Setting and changing the water hardness area is executed in all designs resp. key arrangements analogously.
- For that you always have to use the keys S0, S1, S2 and S3 independent of their variant-dependent program load.
- Key S1 is ALWAYS the "water hardness area key"**
- The water hardness area value 4 is preset by the manufacturer. With setting "1L" it is generally not regenerated. A salt addition is not necessary.
- A possibly existing "salt" LED is not selected.

Electronic and mechanical setting with the appliance:

- In addition to the "electronic" setting on the control panel described on the right you also have to pay attention to the mechanical setting in the appliance by the 2-step blending switch. (see for that the table for hardness area values)

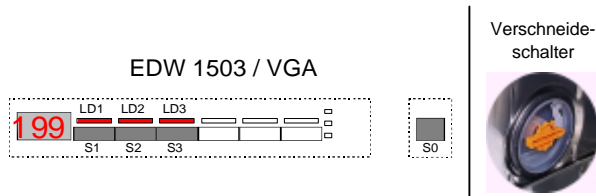
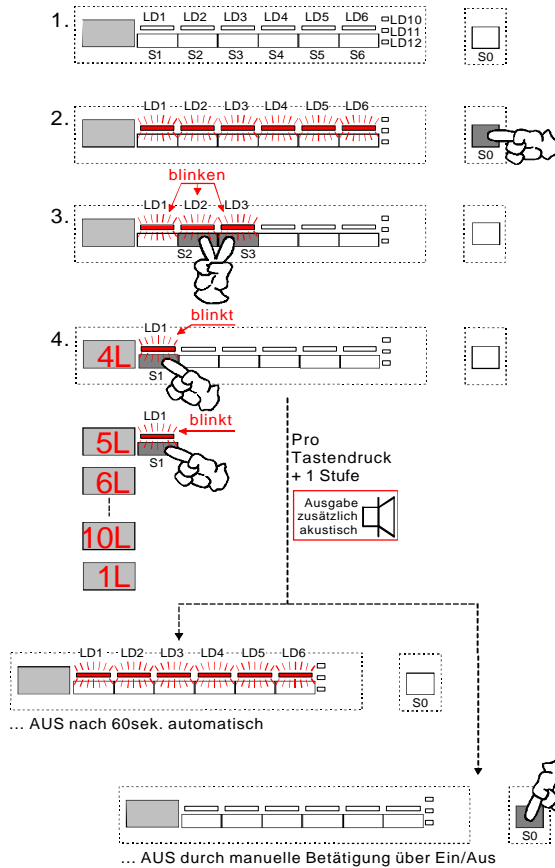

Table for hardness area values:

Anzeige Display	Anzeige Ende-LED	Einstellung der Härtestufe		Wasserhärte			Bemerkung
		Anzahl blinken	elekt. / mech.	in dH	in mmol/L	Bereich	
1L	1 mal	1	0	bis 4	bis 0,7	I	kein Regenerieren
2L	2 mal	2		4 bis 10	0,7 bis 1,8	I / II	
3L	3 mal	3		11 bis 14	1,9 bis 2,5	II	
4L	4 mal	4		15 bis 18	2,6 bis 3,2	III	
5L	5 mal	5	19 bis 22	3,3 bis 3,9			
6L	6 mal	6	23 bis 28	4,0 bis 5,0			
7L	7 mal	7	1	29 bis 36	5,1 bis 6,4	IV	
8L	8 mal	8		37 bis 42	6,5 bis 7,5		
9L	9 mal	9		43 bis 50	7,6 bis 8,9		
10L	10 mal	10		51 bis 70	9,0 bis 12,5		doppelt Regenerieren

Calling / changing / saving the "electronic" hardness area value



Calling the function "set water hardness"

- Appliance in switched-off condition
- Switch on appliance with ON/OFF key S0 -- "prestart" mode
↳ All LEDs of the program and option keys are lit.
- Press keys S2 and S3 simultaneously until the confirmation LEDs LD1, LD2 and LD3 are flashing.
- By actuating the function key S1 you now can call the water hardness function. The confirmation LED LD1 continues flashing, LEDs LD2 and LD3 go out. The set hardness area is indicated in the display and in addition acoustically.
(see for that the table on the left side of this page!)

Changing the set hardness

Any other actuation of the function key S1 changes the hardness area. This increases the value scrolling. (4L - 5L - 6L - ... - 10L - 1L - 2L - ...)

Leaving the function

After the last key pressure of function key S1 you can leave the special program as follows. After 60 seconds all LEDs of the program and option keys are lit automatically. The indication in the display goes out. The appliance is in the "prestart" mode again or the appliance is switched off by the ON/OFF key S0.

Saving the set water hardness

The selected hardness area is saved directly after any entry.

6.12. Customer function / deactivation of rinse-aid addition

General information

The function rinse-aid deactivation does not exist generally and must be programmed in the software variant.

- Deactivation resp. activation of rinse-aid addition is executed in all designs resp. key arrangements analogously.
 - For that you always have to use keys S0, S1, S2 and S3 independent of their variant-dependent program load.
 - **Key S2 is ALWAYS the "rinse-aid deactivation key"**
 - The rinse-aid addition is always set active by the manufacturer.
 - If the rinse-aid addition is deactivated it means that no more rinse-aid is added via the detergent dispenser.
- Along with the deactivation, a variant-dependent existing "rinse-aid" LED is deactivated generally.

EDW 1503 / VGA

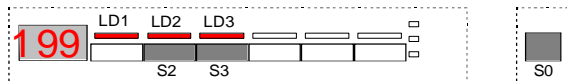

Calling / changing / saving the rinse-aid addition deactivation

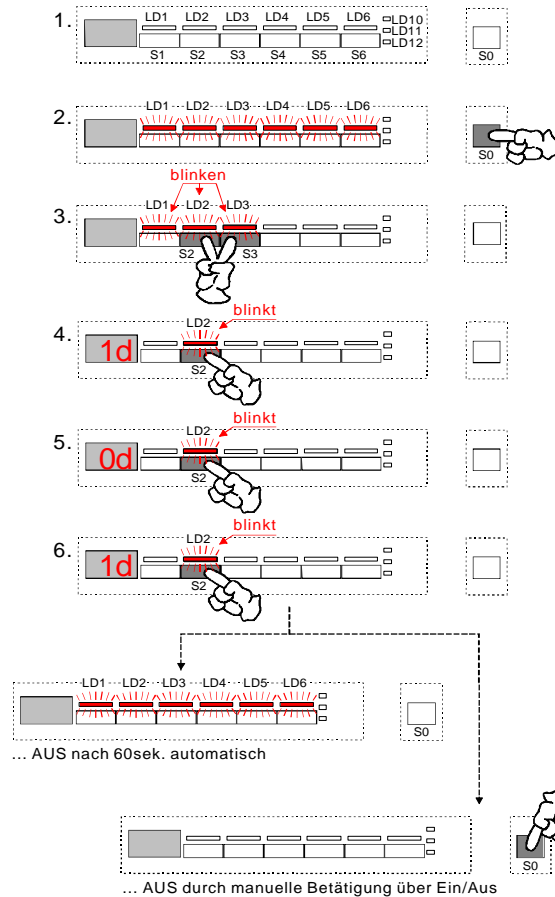

Calling the function "deactivate rinse-aid addition"

1. Appliance in switched-off condition
2. Switch on appliance with ON/OFF key S0 -- "prestart" mode
↳ All LEDs of the program and option keys are lit.
3. Press keys S2 and S3 simultaneously until the confirmation LEDs LD1, LD2 and LD3 are flashing.
4. By actuating the function key S2 you now can call the function rinse-aid addition. The confirmation LED LD2 continues flashing, LEDs LD1 and LD3 go out. The current condition whether the rinse-aid addition is active or not is indicated in the display.
1d = rinse-aid addition on / 0d = rinse-aid addition off

Deactivation resp. activation of rinse-aid addition:

5. / 6. By any further actuation of the function key S2 you activate resp. deactivate the addition alternating.

Leaving the function

After the last key pressure of the function key S1 you can leave the special program as follows.
After 60 seconds all LEDs of the program and option keys are lit automatically. The indication in the display goes out. The appliance is in the "prestart" mode again
or
the appliance is switched off by ON/OFF key S0.

Saving the set condition

The currently valid condition is saved directly after any entry.

6.13. Customer function / deactivation of signal sound

General information

The function deactivation of the signal sound does not exist generally and must be programmed in the software variant.

- Deactivation resp. activation of the signal sound is executed in all designs resp. key arrangements analogously.
- For that you always have to use keys S0, S1, S2 and S3 independent of their variant-dependent program load.
- **Key S3 is ALWAYS the "signal sound deactivation key"**
- The signal sound is always set active by the manufacturer.
- If the signal sound is deactivated it means that in general no acoustic end signal will sound any more. Even the acoustic fault signals cannot be heard any more!

EDW 1503 / VGA

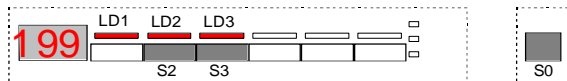

Calling / changing / saving the signal sound deactivation

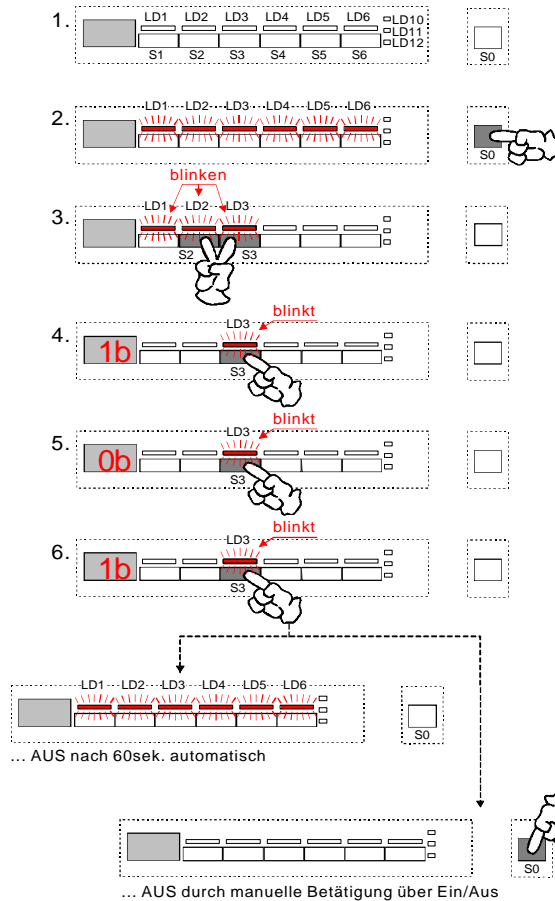

Calling the function "signal sound deactivation"

1. Appliance in switched-off condition
2. Switch on appliance with ON/OFF key S0 -- "prestart" mode
↳ All LEDs of the program and option keys are lit.
3. Press keys S2 and S3 simultaneously until the confirmation LEDs LD1, LD2 and LD3 are flashing.
4. By actuating the function key S3 you now can call the function. The confirmation LED LD3 continues flashing, LEDs LD1 and LD2 go out.
The current condition whether the signal sound is active or not is indicated in the display.
1b = signal sound on / 0b = signal sound off

Deactivation resp. activation of the signal sound:

5. / 6. By any further actuation of the function key S3 you can activate resp. deactivate the signal sound alternating.

Leaving the function

After the last key pressure of the function key S1 you can leave the special program as follows.
After 60 seconds all LEDs of the program and option keys are lit automatically. The indication in the display goes out. The appliance is in the "prestart" mode again
or
the appliance is switched off by ON/OFF key S0.

Saving the set condition

The currently valid condition is saved directly after any entry.

6.14. Service function / readout of fault memory and single actuator selection:

General information

- Calling the service function is executed in all designs resp. key arrangements analogously.
- For that you always have to use keys S0, S1, S2 and S3 independent of their variant-dependent program load.
- In the service function mode key S1 is ALWAYS responsible for the function "readout of fault memory" and "single actuator selection"

EDW 1503 / VGA



It is generally valid:

For calling all service functions you always have first to actuate function keys S1 and S3 before switching on the appliance by ON/OFF switch S0. The keys have to remain pressed about 3 seconds to activate the function. This procedure is intentionally different to that for the customer functions.

Calling above-mentioned service function

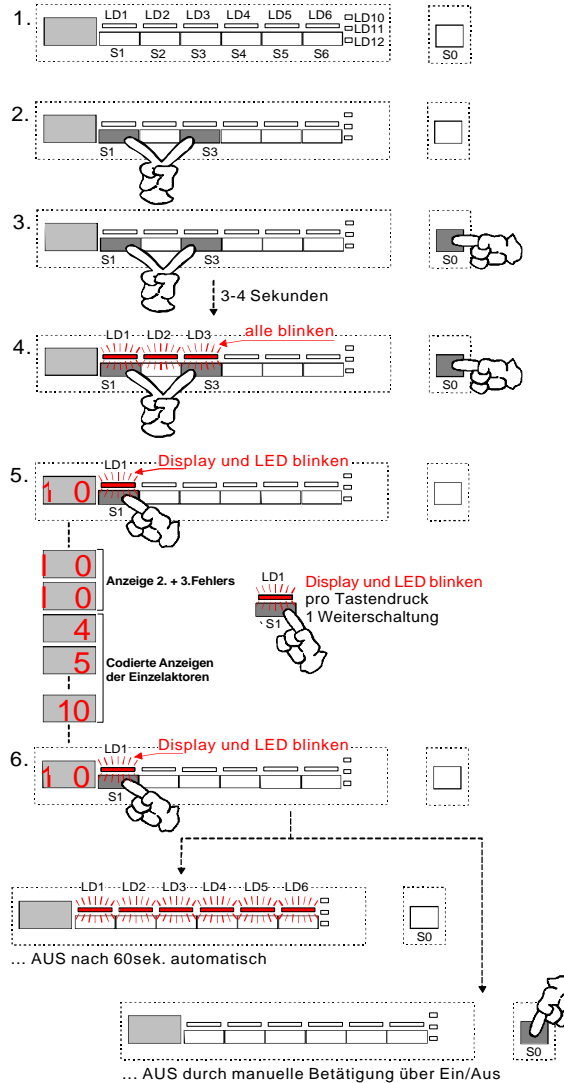

Calling the functions

"readout of fault memory" and "single actuator selection"

1. Appliance in switched-off condition
2. Press keys S1 and S3 simultaneously and ...
3. / 4. ... and switch on the appliance by ON/OFF switch S0. For that keep pressed keys S1 and S3 until the 3 confirmation LEDs LD1, LD2 and LD3 are flashing. (A temporary flashing up of LEDs is possible and no fault!)
5. / 6. By actuating the function key S1 you now can call the function. The confirmation LED LD1 continues flashing, LEDs LD2 and LD3 go out. The first value of the fault memory is indicated in the display. The display indication is flashing. By any further actuation of the function key S1 it is possible to call the next step and indicate it in the display as follows.
 2. actuation: Display of second value of the fault memory
 3. actuation: Display of third value of the fault memory
 4. actuation: Display "4" - selection of regeneration valve
 5. actuation: Display "5" - selection of drain pump
 6. actuation: Display "6" - selection of valve (filling to level - if level already existing, no filling)
 7. actuation: Display "7" - selection of heating (only when level detected)
 8. actuation: Display "8" - selection of circulation pump
 9. actuation: Display "9" - selection of detergent dispenser
 10. actuation: Display "10" - selection of drying fan (see description page B 19 / "Survey of fault displays")
 All positions can be called scrolling as many time as one wants.

The several steps are switched onward manually by pressing any key. If the function key S1 is not pressed within 60 seconds, the service function is left automatically. All LEDs of the program and option keys are lit. The indication in the display goes out. The appliance is in the "prestart" mode again. It is also possible to leave the function by switching off the appliance by ON/OFF key S0.

6.15. Service function / LED test with integrated deletion of the fault memory:

General information

- Calling the service functions is executed in all designs resp. key arrangements analogously.
- For that you always have to use keys S0, S1, S2 and S3 independent of their variant-dependent program load.
- In the service function mode, the key S2 is ALWAYS responsible for the function "LED test with integrated deletion of the fault memory".

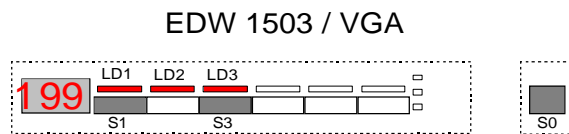

Calling above-mentioned service function

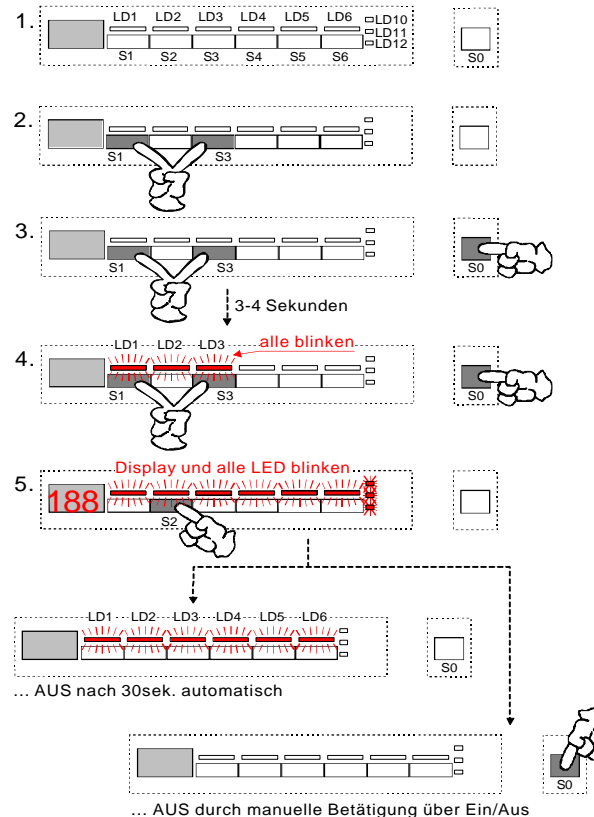

Calling the functions

"LED test with integrated deletion of the fault memory"

1. Appliance in switched-off condition
2. Press keys S1 and S3 simultaneously and ...
3. / 4. ... and switch on the appliance by ON/OFF switch S0. For that keep the keys S1 and S3 pressed simultaneously until the 3 confirmation LEDs LD1, LD2 and LD3 are flashing. (A temporary flashing up of LEDs is possible and no fault!)
5. By actuating the function key S2 you now can call the function. All LEDs and "188" in the display are flashing about 30 seconds.

Leaving the function / deletion of the fault memory

When all above-mentioned LEDs resp. the display have been flashing for about 30 seconds, the function will be left automatically.

All LEDs of the program and option keys are lit. The indication in the display goes out. The appliance is in the "prestart" mode again.

The function can be left even earlier by switching off the appliance by ON/OFF key S0.

In any case, the service fault memory is deleted.

It is generally valid:

For calling all service functions you always have first to actuate the function keys S1 and S3 before switching on the appliance by ON/OFF switch S0. The keys have to remain pressed about 4 seconds to activate the function.

This procedure is intentionally different to that for the customer functions.

6.16. Service function / manufacturing test routine:

General information

- Calling the service functions is executed in all designs resp. key arrangements analogously.
- For that you always have to use keys S0, S1, S2 and S3 independent of their variant-dependent program load.
- In the service function mode, the key S3 is ALWAYS responsible for calling the "manufacturing test routine"

EDW 1503 / VGA

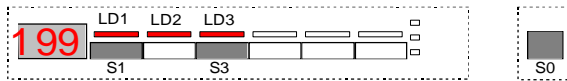

It is generally valid:

For calling all service functions you always have first to actuate the function keys S1 and S3 before switching on the appliance by ON/OFF switch S0! The keys have to remain pressed about 4 seconds to activate the function. This procedure is intentionally different to that for the customer functions.

Calling above-mentioned service function

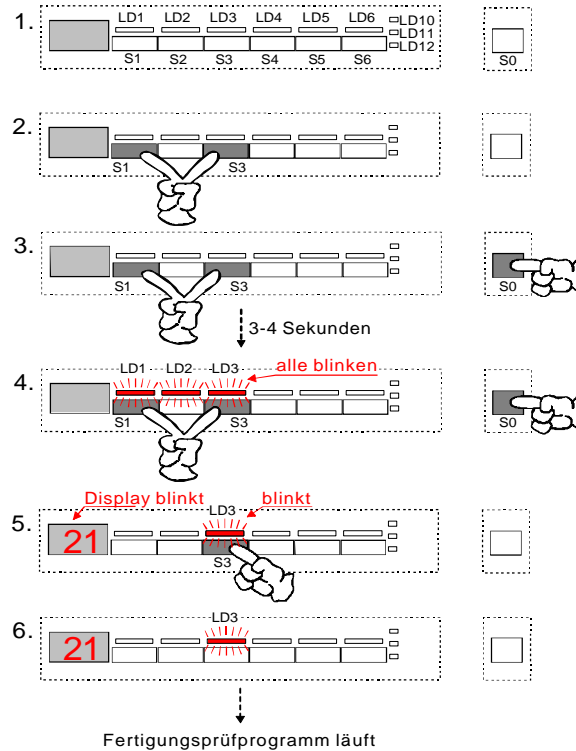

Calling the function "manufacturing test routine"

1. Appliance in switched-off condition
2. Press keys S1 and S3 simultaneously ...
3. / 4. ... and switch on the appliance by ON/OFF switch S0. For that keep the keys S1 and S3 pressed until the 3 confirmation LEDs LD1, LD2 and LD3 are flashing. (A temporary flashing up of LEDs is possible and no fault!)
5. By actuating the function key S3 you can call the manufacturing test routine. The key LED LD3 continues flashing, LEDs LD1 and LD2 go out. The presumable run time is indicated in the display flashing.
6. The test routine starts automatically. The key LED LD3 continues flashing. The display is now indicating the expected run time.

From that moment the same input philosophy is valid for the manufacturing test routine as for normal washing cycles.

- ☞ *cycle run and cycle end*
(see description page B 5)
- ☞ *delete cycle in advance*
(see description page B 6)
- ☞ *interrupt program*
(see description page B 8)

Overview Errors Displayed

Applicable for EDW1500 / 1503 (VGA) -- EDW1100 / 1003 (VGA) -- EDW2000

Error Name	Display on Screen	Display by END LED <small>2Hz / 5sec. Pause</small>	Acoustic Indication <small>No.of Beeps</small> <small>If available for this model</small>	Error Display visible for Customer**		Call Error Memory (Service)		Output via Indicator Lamp <small>If available for this model</small>	Short Explanation	What happens?
				Display PAA	AK	Display PAA	AK			
Water tap closed		1 x flashing	1 x	☺	☺	☺	☺	LED Water	Switchpoint of pressostat is not reached after max. 60 secs. (only in programme steps incl. Filling up to level!)	Programme stops and can be continued after error remedy by pressing the programme key. If fault is not corrected and programme key is pressed, the machine runs dry until next subprogramme.
Drain pump		2 x flashing	2 x	☺	☺	☺	☺	---	Reset point of pressostat is not reached after max. 120secs. Programme stop.	Programme stops and can be continued after error remedy by pressing the programme key.
Aqua-Control		3 x flashing	3 x	☺	☺	☺	☺	---	Aqua-Control System switches off solenoid directly.	Programme stops and restarts automatically when error has terminated.
Recycling pump Triac short-circuit		5 x flashing	5 x	☺		☺	☺	---	Tacho signals are recognized although rec. pump is not selected.	Programme stops and water is filled up until reset point of pressostat
Heating		6 x flashing	6 x			☺	☺	---	During heating, temperature rise by min. 1.5K is not detected within 3min.	Programme is continued until its end without heating function!
NTC Sensor		7 x flashing	7 x			☺	☺	---	NTC short-circuit or break.	Programme is continued until its end without heating function!
EEPROM		8 x flashing	8 x	☺ ?				---	Communication error with ext. EEPROM	
Check sum MCF / CCF		9 x flashing	9 x			☺	☺	---	Check sum (model programming) MCF or Check sum CCF not OK. Only recognized after switching on!	Programme selection not possible. On/Off LED is on
Sprayarm blocked		10 x flashing	10 x		☺	☺	☺	LED Spray arm	At programme start and each subprogramme start, also after door open/close or mains failure, spray arm rotation is checked and evaluated.	Error display until sprayarm speed is recognized, or if no control.
Turbidity sensor		11 x flashing	11 x			☺	☺	---	The turbidity signal required for calibration is not reached with 15secs.	Always recognition of turbidity. Programme sequence is adapted accordingly.
Communication error		12 x flashing	12 x			☺	☺	---	Communication failure with User Interface.	Machine stops, waiting until communication is cleared.
Tacho		13 x flashing	13 x			☺	☺	---	Recycling pump selected, but no tacho signal recognized for 5 + 20 secs	Recycling pump without control, heating off. This function is checked again on each step.
Filling time error		15 x flashing	15 x			☺	☺	---	Time limit during filling exceeded	Programme is completed until next subprogramme without level. No further filling up of water top up. Error is reset after one complete drain cycle.

** = If 7-Segment display available, no PAA error display/Sound error display generally with VGA, with other machines depending on model

List of Possible Error Causes

Code	Possible error causes		
i10	No or not enough water let in	Water tap is closed or faulty No water pressure, pressure too low or changing Screen in front of inlet valve clogged Flow governor at inlet valve faulty Inlet valve faulty Inlet valve deenergized (faulty wiring or no activation by electronics) Inlet hose bent	
	Machine runs dry (Siphon effect)	Softener system clogged (by filling detergent into salt compartment, for instance) Upright installation without upright assembly kit Connection height of the discharge hose is lower than 30cm above appliance base Connection w/o siphon or air chamber	
	Water level inside appliance is not detected	Pressure controller faulty Pressure controller hose obstructed, bent or leaking Pressure controller wiring is faulty Screens in the appliance clogged (also check spray arm nozzles for clogging)	
i20	Water is not pumped off	Fault with discharge pump Discharge pump deenergized (faulty wiring or no activation by electronics) Obstruction/blocking (filters in the appliance, discharge opening in discharge trough, discharge pump, discharge hose, siphon, cover plug at siphon connection not removed during first commissioning) Discharge hose bent or connection height above 100cm Ball valve in discharge trough glued / blocked (discharge pump does not aerate)	
	Water level inside appliance is not detected	Pressure controller faulty Pressure controller hose obstructed or bent Insulation fault with heating element	
i30	Water remains in base trough	Leakage	Leakage at recipient, discharge trough, hose system (e.g., Y-type hose), regeneration dosage etc.
		Overflow	Inlet valve faulty (does not close) Water inlet too high (faulty flow governor at inlet valve) Connecting hose regenerating dosing to discharge trough blocked Water inlet channels in regeneration dosing unit blocked Screens in the appliance clogged (also check spray arm nozzles for clogging) Pressure controller faulty Pressure controller hose obstructed, bent or leaking Pressure controller wiring is faulty Foam production in the appliance (splashed rinsing liquid / leaking dosing unit or con-compatible detergent / rinsing agent used)
	Base trough is dry	Inlet valve or wiring electrically interrupted	
i50	Motor triac short-circuit	Faulty electronics	
i60	No rise in temperature	Heating element faulty Heating element deenergized (faulty wiring or no activation by electronics)	
i70	NTC signal faulty	Thermal sensor defect Wiring faulty (e.g. short-circuit or interruption)	
i80	Check sum error EEPROM	Mains filter defect Faulty electronics EMC problem	
i90	Check sum error model programming	Faulty electronics	
iA0	Upper spray arm does not rotate	Blocking by dishes or cutlery basket Nozzles clogged (drive nozzles at spray arm extremities) Spray arm leaking (welding seam) Spray arm bearing blocked (dirt, foreign bodies) Screens in the appliance clogged Bellows at connecting pipe not sealed at recipient rear wall (bellows not contacting/glued together) Circulating pump does not reach full power (nominal speed is not reached due to winding influence) Too little water in appliance - for possible causes see Error codes i10 and iF0 Foam production in the appliance (splashed rinsing liquid / leaking dosing unit or con-compatible detergent / rinsing agent used)	
	No spray arm detection	No magnet in spray arm Spray arm detection sensor faulty Wiring faulty	
ib0	turbidity signal faulty	turbidity sensor defect Wiring faulty turbidity sensor dirty Foam production in the appliance (splashed rinsing liquid / leaking dosing unit or con-compatible detergent / rinsing agent used)	
ic0	communication faulty	Faulty electronics Wiring faulty	
id0	Circulation pump no function	Circulating pump / capacitor defect Circulating pump deenergized (faulty wiring or no activation by electronics)	
	No tachometer signal recognized	Tachometer generator defect Wiring faulty	
iF0	Time limit during filling exceeded	Problem with water inlet in general - see Error code i10, pipette effect in particular (also look for an error memory entry i10) Problem by incomplete pumping in previous program cycle (remaining water) - see Error code i20 (also look for an error memory entry i20) Improper loading, e.g. big item (pot, bowl is reversed and fills with water) Foam production in the appliance (splashed rinsing liquid / leaking dosing unit or con-compatible detergent / rinsing agent used)	

8. Wirings

8.1 Circuit diagram

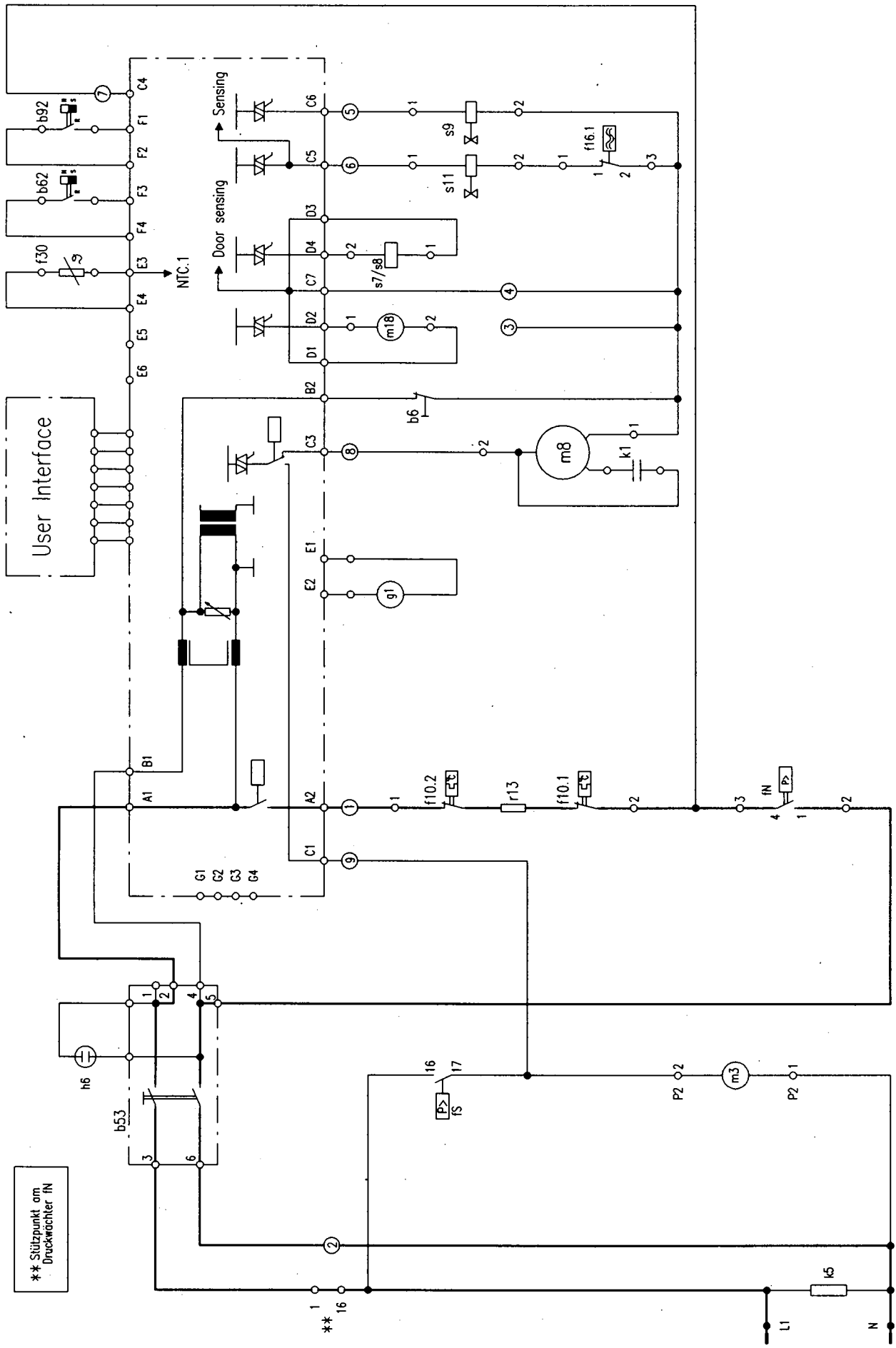

8.2 Wiring diagram

