



INSTRUCTIONS

-J01983

REV. 5-05-2005

Kit Number 68971-98B, 69728-01, and 69723-XX

HEADLAMP VISOR KIT

General

Kit Number 68971-98B is designed to fit 1984-1999 FXST, FXSTC models.

Kit Number 69728-01 is designed to fit 1991-2005 FXDWG models (Will not fit FXSTB models.).

Kit Number 69723-XX is designed to fit 1991-2005 FXD, FXDC, FXDWG, and 2006 and later FXDL, FXDB and FXD models.

NOTE

A Service Manual for your motorcycle is available from your Harley-Davidson Dealer.

See Service Parts illustration for kit contents.

Installation

1. See Service Parts illustration. Install the edge gasket (4) to the headlamp visor (1). The gasket should be installed at the headlamp opening as indicated in illustration. When installing gasket, start at the top of the headlamp opening and work the gasket into place, finishing with the seam top.
2. See Figure 1. Remove headlamp assembly from motorcycle according to Service Manual instructions. Save all hardware for reinstallation, except mounting block (1) and screw (2) as shown. These may be stored for use without the Headlamp Visor in place.

NOTE

Take care while removing headlamp not to scratch any chrome surfaces.

3. See Figure 1. (For 2005 and earlier models) Replace existing mounting block with mounting block from kit (2) and secure with screw (7) as shown. The mounting block should be positioned with the through hole positioned forward and to the front as shown. Leave loose until Step 4 is completed.
4. Position visor bracket (3) on back of headlamp. Secure headlamp to mounting block (2) using existing bolt, washers and nut removed in Step 2. Align headlamp using procedure in appropriate Service Manual.
5. See Service Parts Illustration. Attach the headlamp visor (1) to the bracket with the 5 screws (5) and 5 washers (6) as shown and tighten to 40 in-lbs (4.5 N-m).

NOTE

If the clutch cable is rubbing on the headlamp visor, proceed to Step 6.

6. See Figure 2. Relocate clutch cable to the inside of the handlebars as shown in illustration as follows:
 - a. Slide rubber boot off cable adjuster. Adjuster is located approximately halfway along clutch cable by the front frame downtube.
 - b. Holding cable adjuster with 1/2 inch wrench, loosen jam nut using a 9/16 inch wrench. Back jam nut away from cable adjuster. Move adjuster toward jam nut to introduce a large amount of freeplay at the hand lever.

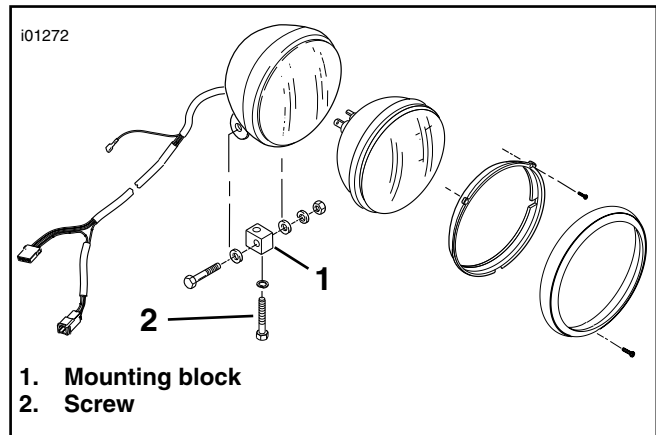

Figure 1. Headlamp assembly (FXSTC shown)

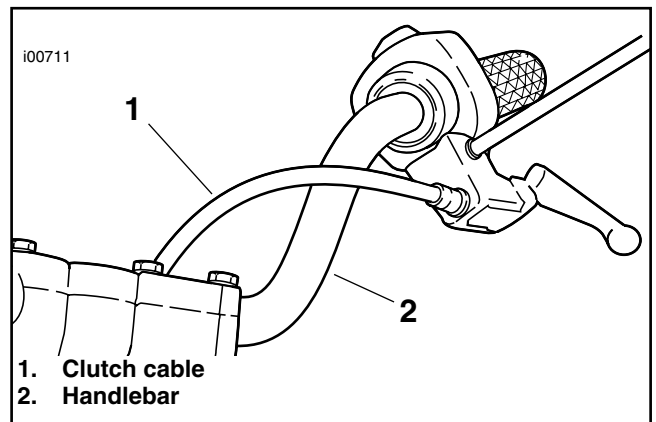

Figure 2. New Clutch Cable Routing

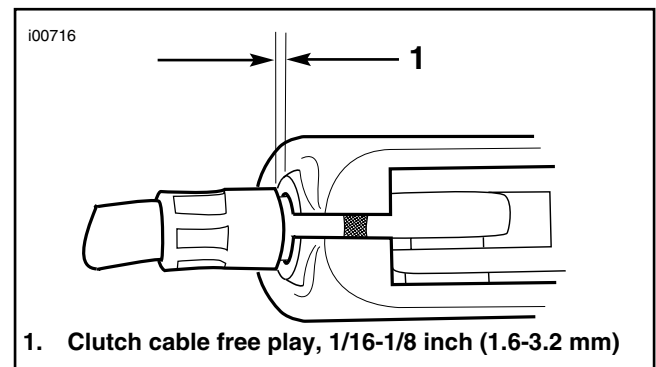

Figure 3. Clutch Cable Adjustment

- c. Remove small snap ring from pivot pin groove at bottom of clutch lever bracket. Remove pivot pin and clutch hand lever from bracket.
- d. Reroute clutch cable to the inside of the handlebars as shown in Figure 2 and reconnect clutch cable to clutch lever by reversing step c.



Service Parts

Part No. 68971-98A, 69728-01, 69723-XX | Date 5/05

Headlamp Visor Kits

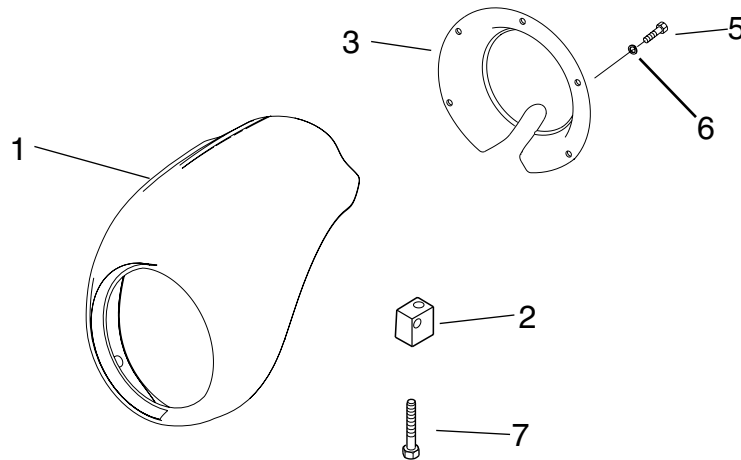

ITEM	DESCRIPTION	PART NUMBER	ITEM	DESCRIPTION	PART NUMBER
1	Headlamp visor	Not sold separately	4	Gasket (not shown)	68134-97
2	Headlamp mounting block	67627-97	5	Screws, buttonhead (5)	4363
3	Visor bracket	90338-01	6	Washer (5)	6424
			7	Screw, hex head, mounting block	4722

Note

Item 2, headlamp mounting block and item 7, hex head mounting block screw are only used on 2005 and earlier models.

Note

Place gasket around interior edge of headlamp visor opening.