

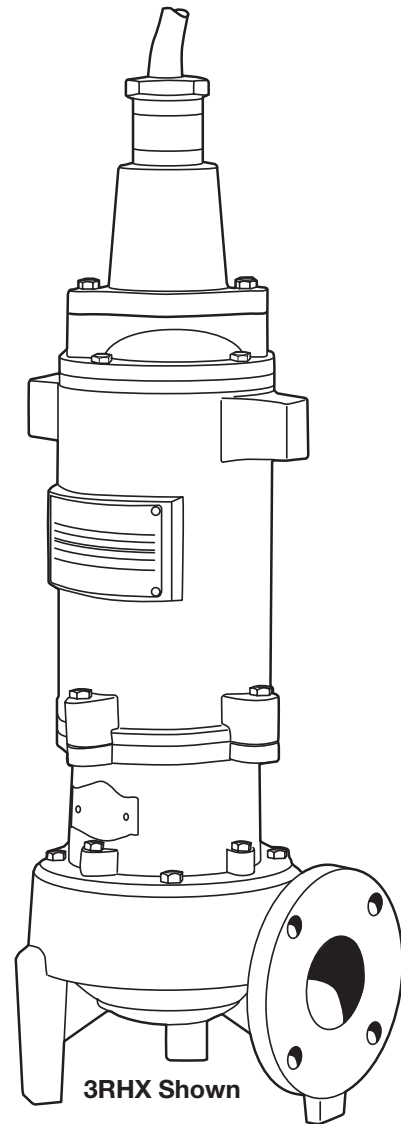

MYERS®



MODELS 3V(X*), 3R(X*),
3RH(X*), 4V(X*) and 4R(X*)

*Used in Hazardous Locations Class I, Division 1, Groups C & D

SUBMERSIBLE SOLIDS HANDLING PUMPS

INSTALLATION AND SERVICE MANUAL

For use with product built with Regal motor.

NOTE! To the installer: Please make sure you provide this manual to the owner of the equipment or to the responsible party who maintains the system.

(*Hazardous Location
Motor End)



CAUTION!

Read these safety warnings first before installing, servicing, or operating any pump.

CALIFORNIA PROPOSITION 65 WARNING:

▲ WARNING This product and related accessories contain chemicals known to the State of California to cause cancer, birth defects or other reproductive harm.

GENERAL

1. Most accidents can be avoided by using **COMMON SENSE**.
2. Read the operation and maintenance instruction manual supplied with the pump.
3. Do not wear loose clothing that can become entangled in the impeller or other moving parts.
4. This pump is designed to handle materials that could cause illness or disease through direct exposure.

Wear adequate protective clothing when working on the pump or piping.

ELECTRICAL

5. To reduce the risk of electrical shock, pump must be properly grounded in accordance with the National Electric Code and all applicable state and local codes and ordinances.
6. To reduce risk of electrical shock, disconnect the pump from the power source before handling or servicing.
7. Any wiring to be done on pumps should be done by a qualified electrician.
8. Never operate a pump with a power cord that has frayed or brittle insulation.
9. Never let cords or plugs lie in water.
10. Never handle connected power cords with wet hands.

PUMPS

11. Pump builds up heat and pressure during operation; allow time for pump to cool before handling or servicing.
12. Only qualified personnel should install, operate or repair pump.
13. Keep clear of suction and discharge openings. **DO NOT** insert fingers in pump with power connected.
14. Do not pump hazardous material not recommended for pump (flammable, caustic, etc.).
15. Make sure lifting handles are securely fastened each time before lifting.
16. Do not lift pump by the power cord.

17. Do not exceed manufacturer's recommendation for maximum performance, as this could cause the motor to overheat.
18. Secure the pump in its operating position so it cannot tip over, fall or slide.
19. Keep hands and feet away from impeller when power is connected.
20. Submersible solids handling pumps are not approved for use in swimming pools, recreational water installations, decorative fountains or any installation where human contact with the pumped fluid is common.
21. Do not operate pump without safety devices in place.

IMPORTANT! Myers® is not responsible for losses, injury or death resulting from a failure to observe these safety precautions, misuse or abuse of pumps or equipment.

GENERAL INFORMATION:

Pump Models: These instructions cover the installation and service of the Myers pumps as listed on the front cover. The hazardous location models are Factory Mutual approved and listed hazardous location for hazardous sewage locations Class 1, Division 1, Groups C,D.

Motor HP & Voltages: These pumps are offered in a three phase wiring configuration only. Voltages will vary according to the application.

Electrical Controls: All of these pump models must be used with a control panel. Myers built control panels are designed to supply the correct electrical controls, motor starting equipment and include the circuitry for moisture and heat sensors. It is recommended that a Myers built control panel be used so that all warranties apply.

General Construction: The motor construction is designed to meet Factory Mutual's requirements for Class 1, Division 1, Groups C,D sewage applications. The hazardous location models are certified and nameplated with this approval. The motor chamber and seal chamber are filled with a high dielectric type oil for improved lubrication and heat transfer of the bearings and motor. Since the bearings have been designed for 50,000 hours of life, the oil should never require replacement under normal operating conditions. An air space above the oil level in both the seal and motor chambers is provided to allow for the expansion of the oil when at operating temperature. The power and control lines are sealed and strain relieved by grommet in the cord cap, and internally through the use of a dielectric potting resin surrounding the electrical wires. All of the pump fasteners and shafts are made from corrosion resistant stainless steel, while the pump castings are made of ASTM A-48 Class 30 cast iron.

General Installation: Various configurations and methods of plumbing this series of solids handling pumps may be used; however, for ease of installation and service a Myers® 3" or 4" rail lift-out system is recommended.

Note: If the hazardous location pumps are used in conjunction with a rail lift-out system, it must be an FM approved nonsparking, hazardous location system. The Myers approved lift-out models are:

3" Liftout	4" Liftout
SRAX3030	SRAX4040
SRAX33HH	SRAX44HH

If these guidelines are not followed, the Factory Mutual approval is void.

Hazardous Location Service: These pumps are to be used for handling sewage, wastewater and storm water only. Do not use in other hazardous locations. These pumps must be repaired and serviced only at Myers authorized service centers or at the Myers factory. Any unauthorized field repair voids warranty, hazardous location rating and Factory Mutual approval.

CAUTION: After the pump is installed and sewage has entered the basin there are methane and hydrogen sulfide gases, which are poisonous. Never enter a wet well unless the cover is open for a sufficient period of time to allow fresh air into the basin. Myers recommends using the rail lift-out system so that no service is required inside the basin.

Motor: Each motor is provided with heat sensor thermostats attached directly to the motor windings. The thermostats open if the motor windings see excessive heat and, in turn, open the motor contactor in the control panel, breaking the power to the pump. When the motor is stopped due to an overheated condition, it will not start until the motor has cooled and the heat sensor reset button is manually pushed on the front of the Myers control panel. This circuitry is provided in the Myers control panel designs.

Thermostats are set to open at a temperature of 248°F (120°C). The maximum contact rating is 18 amps at 115 VAC and 12 amps at 230 VAC. Motor winding insulation is good for Class F (311°F, 155°C).

Note: Failure to use proper circuitry and to connect the motor overheat protection in the control panel would negate all warranties and FM approval.

Motor Seal Failure Warning: The seal chamber is oil filled and provided with moisture sensing probes to detect water leakage through the lower shaft seal. The probes can also detect moisture present in the upper motor housing.

The presence of water energizes a red seal leak warning light at the control panel. This is a warning light only, and does not stop the motor. It indicates a leak has occurred and the pump must be repaired. Normally, this indicates the outboard seal has leaked. Allowing the unit to operate after the warning could cause upper seal leakage along with motor failure.

The resistance across the moisture sensing (seal failure) probes should be checked after a seal leak warning light has lit. This can be done by disconnecting the red and orange control wires from the control panel, and measuring the resistance with an ohmmeter between the wires. If the measured values are below specification, the pump may have a lower seal failure and require service.

On the Myers hazardous location control panels the seal leak test switch tests the seal leak circuit continuity. When pushed, the seal leak test bulb should light. If the test bulb does not light it means either the wiring circuitry to the seal leak probes has been broken or the bulb has burned out.

Note: Myers built control panels supply the correct circuitry for moisture and heat sensor connections. Failure to install the correct circuitry with proper connection would negate warranty and FM approval.

Motor Power Cord, Control Cord and Cord Cap Assembly: Each motor power cord has 4 conductors: white, black, red and green. For a three phase motor the red, black and white conductors connect to the three line leads, and the green is connected to a good ground. Interchanging any two line leads will reverse the rotation of the motor.

Note: Rotation should be clockwise when observed from the top of the pump. This can be checked by noting which direction the pump torque is up on initial starting. A properly rotating pump will torque counterclockwise upon start.

The control cable has 5 conductors: black, white, red, orange and green. White and black connect to the heat sensor terminals in the control panels; red and orange connect to the seal failure terminals in the control panel; and the green connects to the ground in the control panel.

The cord cap is epoxy potted. The cord cap provides for a sealed wire connection. This allows the cord cap, with cords, to be removed from the motor. An approved hazardous location junction box is required for hazardous locations. **The control and power cables cannot be spliced!**

Note: Each cable has a green ground wire and must be properly grounded per the National Electric Code and local codes.

Electrical Motor Controls: All electrical controls and motor starting equipment should be as specified in these instructions. Consult factory for any acceptable alternatives. For hazardous locations the controls and control panel must be installed outside the hazardous area, or approved hazardous location controls that are intrinsically safe must be used.

Junction Box: If a junction box is used in a hazardous location, it must be a hazardous location approved type with hazardous location cord connectors. Wires from the junction box must pass through a hazardous location seal connector.

Level Sensing Controls: Intrinsically safe type float controls are recommended for all applications and required for hazardous location service. An intrinsically safe control panel relay will limit the current and voltage to the level controls. A Myers® control panel can be supplied with this type circuitry.

The float level controls maintain the basin sewage water level by controlling pump turn-on and turn-off levels.

1. The lower turn-off control should be set so that the pump stops at approximately the top of the pump. Consult the factory for any settings below this point.
2. The upper turn-on control should be set above the lower turn-off control. The exact height between the two controls is determined by the number of pump starts desired and the depth of the basin. A maximum of 10 starts per hour should not be exceeded.
3. The override control is set at a specified height above the upper turn-on control.
4. The alarm control is set about 6" to 12" above the override control.
5. No control should be set above the inlet invert.

Electrical Connections: All electrical wiring must be in accordance with local code and only qualified electricians should make the installations. All wires should be checked for shorts to ground with an ohmmeter or megger after the connections are made. This is important, as one grounded wire can cause failure of the pump, control panel or personal injury.

WARNING: Disconnect pump from power source before servicing or handling pump.

Disassembly

1. With the pump located in a secure place, remove the bolts fastening the seal housing to the volute. The motor and impeller can now be removed as a unit.
2. Lay the unit down on its side. If the lower seal is to be removed, it is recommended that the oil in the seal chamber be drained. This can be done by

removing the lower seal chamber plug and draining the oil into a holding container.

3. To remove the impeller: Using a proper wrench, the impeller retaining bolt and washer must be removed. This may require a piece of wood placed between the vanes to keep the impeller from rotating while removing the bolt. Once the bolt has been removed, tap lightly with a hammer around the outside diameter of the impeller to loosen from shaft and key. After removing impeller, the seal retainer needs to be removed to expose seal.

Caution: The impeller is large and heavy and will need to be supported.

4. If the lower seal needs removed, first remove the compression spring that rides between the impeller and the seal assembly. Next take a pair of screwdrivers and remove the compression ring that surrounds the rubber bellows on the rotating portion of the seal assembly. Again using the screwdrivers, pry the remaining portion of the rotating seal assembly off the shaft. The ceramic stationary can be removed by placing a screwdriver between the rubber and the ceramic face, and then prying, working around the entire diameter. Note, these parts should be discarded and a new seal assembly installed.
5. If the oil in the seal chamber was drained, examine the contents to determine if the upper seal has been damaged. Signs of grit or other abrasive material may indicate that the upper seal has also been damaged. Pressurizing the motor housing assembly between 7 and 10 psi and observing any drop in pressure will indicate if the upper seal is functioning properly.
Note: Upper seal repairs must be done at a Myers authorized service center or at the Myers factory. Any unauthorized field repair voids warranty and the hazardous location approval on the Factory Mutual listed pump.
6. The wear ring can be removed from the volute for repair or replacement. First remove the retaining screws from the wear ring. With a soft mallet the wear ring can be tapped out of the volute case.

Reassembly

1. Remove the ceramic portion of the new seal from the package. Brush new dielectric oil or glycerine around the rubber portion of the stationary assembly and into the pocket in the seal housing. Note, keep the oil off the seal face. Without scratching the seal face, press the ceramic stationary portion into the seal housing using a Myers seal pusher. With clean cloth, lightly wipe the face of the seal surface to make sure it is dirt free. Remove the rotating portion of the seal from the package and lubricate the inside diameter of the rubber bellows and the outside diameter of the shaft. Place the seal over the shaft (make sure the key is removed). Evenly press on the body of the rotational assembly and slide it down the shaft

until the seal faces meet. Once the seal assembly is in position, place the spring over the register on the rotational portion of the seal.

2. Before placing impeller on shaft, the seal spring retainer should be placed on shaft with stepped end toward seal spring. Position the key into the seat in the shaft. Align the impeller onto the shaft, making sure that the seal spring is registered properly onto the back side of the impeller. Insert the bolt and washer assembly into the shaft and tighten to 43 ft.-lbs.
3. Fill the seal chamber with new dielectric oil. An air gap of 10–15% volume must be left for the expansion of the oil when it is at operating temperature.

4. The brass wear ring can be aligned with the retaining holes and tapped into place with a soft mallet. The proper Loctite® should be applied to the bolts. Install and tighten.
5. The motor and impeller assembly can be installed into the volute. Make sure that the impeller aligns properly with the volute. Install the volute retaining bolts and tighten.
6. Air tends to trap in the pump case when water rises in the sump or when the pump is lowered into the water after service. To vent off this air, a small hole is drilled into the volute casing.
Be sure this vent hole is clean after any service work on pump. Air venting is not a problem after initial start.

CHECK LIST IF PUMP DOES NOT OPERATE PROPERLY

Checking for Moisture in Motor: Use an ohm-meter or a megger and set on highest scale. Readings on the large power cord between any of the conductors red, black or white to the green conductor or to the motor housing should be greater than 1,000,000 ohms (1 megohm). Service work should be done only at an authorized service station. Note, readings should be taken with line leads disconnected from the control panel.

Resistance of Windings: Every motor winding has a fixed resistance. The windings must check close to specification values. Verification of the proper wiring of a dual voltage motor can also be checked by measuring the motor winding resistance.

CONDITION

Red light comes on at control box.

PROBABLE CAUSE

This indicates some water has leaked past the lower seal and has entered the seal chamber and made contact with the electrode probe. Pump must be removed for replacement of lower seal. This preventive repair will save an expensive motor.

Overload trips at control box and alarm buzzer or flashing red light comes on due to high water level in basin.

1. Push in on red reset button to reset overload. If overload trips again after short run, pump has some damage and must be removed from basin for checking.
2. Trouble may be from clogged impeller causing motor to overload or could be from failed motor.
3. Trouble may be from faulty component in control box. Always check control box before removing pump.

Yellow run light stays on continuously.

1. Indicates H-O-A switch may be in the hand position.
2. Level control switch may have failed causing pump to continue to operate when water is below lower control.
3. Impeller may be partially clogged causing pump to operate at very reduced capacity.
4. Gate valve or check valve may be clogged causing low pump flow.
5. Pump may be air locked.

CONDITION

Circuit breaker trips.

PROBABLE CAUSE

1. Reset breaker by pushing completely down on handle then back to ON position. If breaker trips again in a few seconds it indicates excessive load probably caused by a short in the motor or control box. Check out instructions given with control box before pulling pump.
2. If this condition happens after an electrical storm, motor or control box may be damaged by lightning.
3. Resistance reading of the motor with lead wires disconnected from the control box can determine if trouble is in motor or control box.

Pump is noisy and pump rate is low.

1. Impeller may be partially clogged with some foreign objects causing noise and overload on the motor.
2. Impeller may be rubbing on wear ring due to bent shaft or misalignment.
3. Pump may be operating too close to shut-off. Check head.

Grease and solids have accumulated around pump and will not pump out of basin.

1. Lower control switch may be set too high.
2. Run pump on hand operation for several minutes with small amount of water running into basin to clean out solids and grease. This allows pump to break suction and surge which will break up the solids. If level switch is set properly this condition generally will not occur.
3. Trash and grease may have accumulated around floats causing pump to operate erratically.

MOTOR SPECIFIC PARTS LISTS

3R/3RX

2 POLE		5HP	5HP	5HP	5HP	5HP	7.5HP	7.5HP	7.5HP
		230/1	200/3	230/3	460/3	575/3	230/3	460/3	575/3
	MPG	27695P388	27695P389	27695P390	27695P391	27695P392	27695P348	27695P349	27695P450
A1	STATOR	22574C200	22574C201	22574C202	22574C202	22574C204	22574C216	22574C216	22574C217
A2	ROTOR/SHAFT	22846C111	22846C112	22846C112	22846C112	22846C112	22846C111	22846C111	22846C111
A3	BEARING	08565A022	08565A022	08565A022	08565A022	08565A022	08565A022	08565A022	08565A022
A4	BEARING	08565A023	08565A023	08565A023	08565A023	08565A023	08565A023	08565A023	08565A023
A5	SHAFT SEAL	04916-000-1	04916-000-1	04916-000-1	04916-000-1	04916-000-1	04916-000-1	04916-000-1	04916-000-1

3RH/3RHX

2 POLE		3 HP	3 HP	3 HP	3 HP	5 HP	5 HP	5 HP	5 HP	7.5 HP	7.5 HP	7.5 HP
		230/1	200/3	230-460/3	575/3	230/1	200/3	230-460/3	575/3	200/3	230-460/3	575/3
A1	STATOR	22574C210	22574C211	22574C212	22574C214	22574C200	22574C201	22574C202	22574C204	22574C215	22574C216	22574C217
A2	ROTOR	26124C000	26124C001	26124C001	26124C001	26124C002	26124C003	26124C003	26124C003	26124C002	26124C002	26124C002
A3	BEARING	08565A022	08565A022	08565A022	08565A022	08565A022	08565A022	08565A022	08565A022	08565A022	08565A022	08565A022
A4	BEARING	25833A003	25833A003	25833A003	25833A003	25833A003	25833A003	25833A003	25833A003	25833A003	25833A003	25833A003
A5	SHAFT SEAL	04916-000-1	04916-000-1	04916-000-1	04916-000-1	04916-000-1	04916-000-1	04916-000-1	04916-000-1	04916-000-1	04916-000-1	04916-000-1

3V/3VX

4 POLE		1/1.5 HP	1/1.5 HP	1/1.5 HP	1/1.5 HP	2 HP	2 HP	2 HP	2 HP	3 HP	3 HP	3 HP	3 HP
		230/1	200/3	230-460/3	575/3	230/1	200/3	230-460/3	575/3	230/1	200/3	230-460/3	575/3
A1	STATOR	24407C241	24407C242	24407C243	24407C244	24407C245	24407C246	24407C247	24407C248	24407C200	24407C201	24407C202	24407C203
A2	ROTOR	22875C108	22875C115	22875C115	22875C115	22875C110	22875C107	22875C107	22875C107	22875C105	22875C105	22875C105	22875C105
A3	BEARING	08565A022	08565A022	08565A022	08565A022	08565A022	08565A022	08565A022	08565A022	08565A022	08565A022	08565A022	08565A022
A4	BEARING	08565A027	08565A027	08565A027	08565A027	08565A027	08565A027	08565A027	08565A027	08565A027	08565A027	08565A027	08565A027
A5	SHAFT SEAL	009200011	009200011	009200011	009200011	009200011	009200011	009200011	009200011	009200011	009200011	009200011	009200011

4V/4VX

4 POLE		3 HP	3 HP	3 HP	3 HP	5 HP	5 HP	5 HP	5 HP	7.5 HP	7.5 HP	7.5 HP
		230/1	200/3	230-460/3	575/3	230/1	200/3	230-460/3	575/3	200/3	230-460/3	575/3
A1	STATOR	24407C200	24407C201	24407C202	24407C203	24407C204	24407C205	24407C206	24407C207	24407C208	24407C209	24407C210
A2	ROTOR	22875C105	22875C105	22875C105	22875C105	22875C105	22875C105	22875C105	22875C105	22875C105	22875C105	22875C105
A3	BEARING	08565A022	08565A022	08565A022	08565A022	08565A022	08565A022	08565A022	08565A022	08565A022	08565A022	08565A022
A4	BEARING	08565A027	08565A027	08565A027	08565A027	08565A027	08565A027	08565A027	08565A027	08565A027	08565A027	08565A027
A5	SHAFT SEAL	009200011	009200011	009200011	009200011	009200011	009200011	009200011	009200011	009200011	009200011	009200011

3R/3RX / 4R/4RX

4 POLE		2HP	2HP	2HP	2HP	3 HP	3 HP	3 HP	3 HP
		230/1	200/3	230-460/3	575/3	230/1	200/3	230-460/3	575/3
A1	STATOR	24407C245	24407C246	24407C247	24407C248	24407C200	24407C201	24407C202	24407C203
A2	ROTOR	22846C098	22846C099	22846C099	22846C099	22846C100	22846C100	22846C100	22846C100
A3	BEARING	08565A022	08565A022	08565A022	08565A022	08565A022	08565A022	08565A022	08565A022
A4	BEARING	08565A023	08565A023	08565A023	08565A023	08565A023	08565A023	08565A023	08565A023
A5	SHAFT SEAL	04916-000-1	04916-000-1	04916-000-1	04916-000-1	04916-000-1	04916-000-1	04916-000-1	04916-000-1

3R/3RX / 4R/4RX

4 POLE		5 HP	5 HP	5 HP	5 HP	7.5 HP	7.5 HP	7.5 HP
		230/1	200/3	230-460/3	575/3	200/3	230-460/3	575/3
A1	STATOR	24407C204	24407C205	24407C206	24407C207	24407C208	24407C209	24407C210
A2	ROTOR	22846C100	22846C100	22846C100	22846C100	22846C100	22846C100	22846C100
A3	BEARING	08565A022	08565A022	08565A022	08565A022	08565A022	08565A022	08565A022
A4	BEARING	08565A023	08565A023	08565A023	08565A023	08565A023	08565A023	08565A023
A5	SHAFT SEAL	04916-000-1	04916-000-1	04916-000-1	04916-000-1	04916-000-1	04916-000-1	04916-000-1

4R/4RX

6 POLE		1 HP	1 HP	1 HP	1 HP	1.5 HP	1.5 HP	1.5 HP	1.5 HP	2 HP	2 HP	2 HP	2 HP
		230/1	200/3	230-460/3	575/3	230/1	200/3	230-460/3	575/3	230/1	200/3	230-460/3	575/3
A1	STATOR	24407C223	24407C224	24407C225	24407C226	24407C227	24407C228	24407C229	24407C226	24407C231	24407C232	24407C233	24407C234
A2	ROTOR	22846C105	22846C104	22846C104	22846C104	22846C110	22846C102	22846C102	22846C104	22846C100	22846C100	22846C102	22846C102
A3	BEARING	08565A022	08565A022	08565A022	08565A022	08565A022	08565A022	08565A022	08565A022	08565A022	08565A022	08565A022	08565A022
A4	BEARING	08565A023	08565A023	08565A023	08565A023	08565A023	08565A023	08565A023	08565A023	08565A023	08565A023	08565A023	08565A023
A5	SHAFT SEAL	04916-000-1	04916-000-1	04916-000-1	04916-000-1	04916-000-1	04916-000-1	04916-000-1	04916-000-1	04916-000-1	04916-000-1	04916-000-1	04916-000-1

MOTOR END PARTS

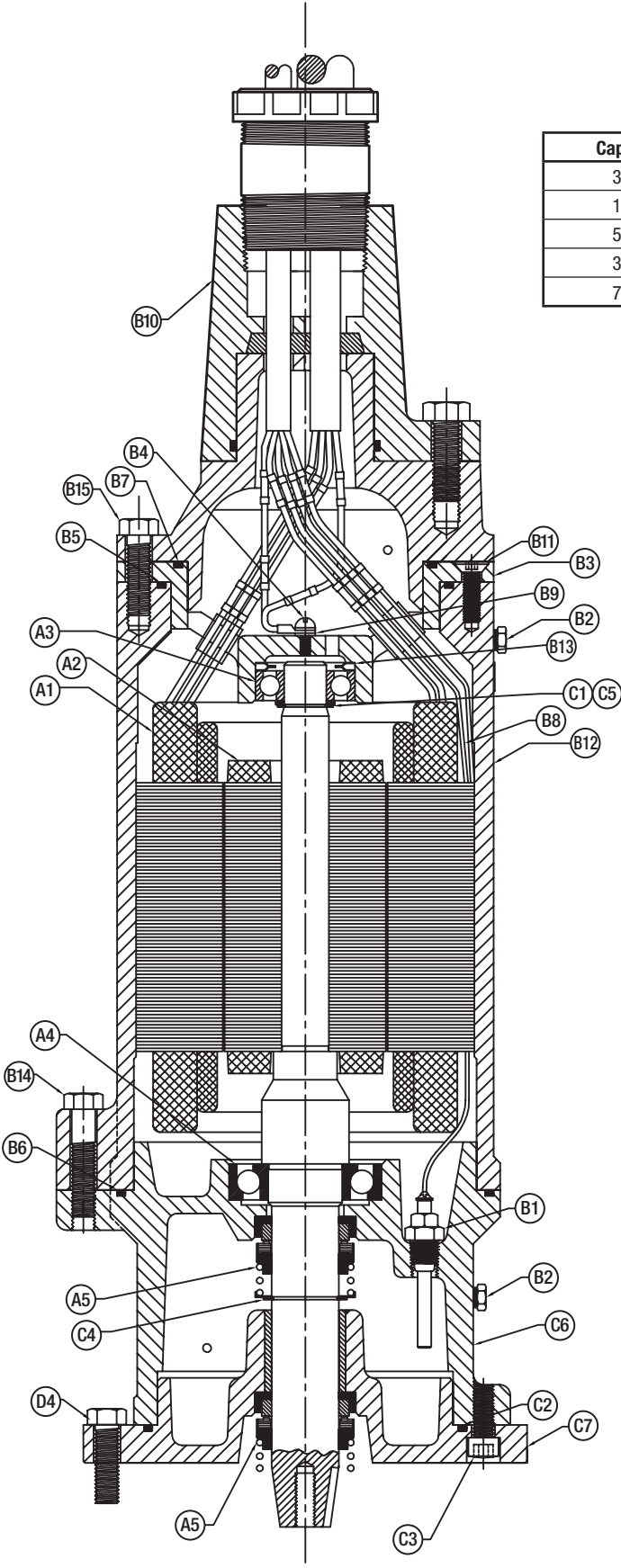

Cap Screw	Torque Value
3/8-16	20 ft.-lbs.
1/2-13	43 ft.-lbs.
5/8-11	93 ft.-lbs.
3/4-10	128 ft.-lbs.
7/8-14	193 ft.-lbs.

COMMON PARTS LIST

For use with product built with Regal motor.

Ref.	Part Number	Description	Qty.
B1	25343A100	PROBE; SEAL LEAK FOR 3-20HP	2
B2	05022A092	PLUG; PIPE ST GALV 1/4 HEX HD w/LOCTITE 513 COATING	2
B3*	22590B000 (x)	CAP, BEARING; UPPER 5HP GRINDER PUMP CI	1
B4	05434A043	SCREW; MACH ST 10-24UNC x 3/8 LG	1
B5	05876A112	RING, O; 5-1/2 OD x 5-1/4 ID x 1/8	1
B6	05876A114	RING, O; 7 OD x 6-3/4 ID x 1/8	1
B7	05876A123	RING, O; 4-7/8 OD x 4-5/8 ID x 1/8	1
B8	22578A100	WIRE; ELECTRODE FOR 3-20HP	2
B9	06107A015	WASHER; LOCK SHKPRF INTERNAL ST NO 10	1
B10	22569B104	35' CORD ASSEMBLY 14-4 - ORDINARY LOCATION	1
	22569B031	35' CORD ASSEMBLY 10-4 - ORDINARY LOCATION	1
	22569B032	35' CORD ASSEMBLY 8-4 SOOW - ORDINARY LOCATION	1
	22569B102	35' CORD ASSEMBLY 8-4 W - ORDINARY LOCATION	1

Ref.	Part Number	Description	Qty.
B10	22569B702	35' CORD ASSEMBLY 14-4 - HAZARDOUS LOCATION	1
	22569B631	35' CORD ASSEMBLY 10-4 - HAZARDOUS LOCATION	1
	22569B632	35' CORD ASSEMBLY 8-4 SOOW - HAZARDOUS LOCATION	1
	22569B700	35' CORD ASSEMBLY 8-4 W - HAZARDOUS LOCATION	1
B11	07597A017	SCREW; MACH FLT HD HEX SKT SST 5/16-18UNC-3A x 1LG	2
B12*	22571D000 (x)	HOUSING; MOTOR 5HP GRINDER PUMP CI	1
B13	19331A006	WASHER; SPRING FINGER 1.189 ID x 1.830 OD	2
B14	19102A023	SCREW; CAP HEX SST 302 7/16-14NC x 2-1/4	4
B15	19102A006	SCREW; CAP HEX 7/16-14 UNC SST 1-1/2	4

MODEL SPECIFIC PARTS LIST

Ref.	Description	Qty.	3RH/3RHX	3V/4V/3VX/4VX	3R/3RX/4R/4RX
C1	WASHER; SUPPORT ST 1.1/1.09 x .789/.799	1	05030A215	--	--
C2	O-RING	1	05876A113	05876A127	05876A113
C3	SCREW; CAP SKT HD SST 3/8-16UNC-3A x 1LG	4	06106A028	19102A006	06106A028
C4	RING; RET EXTERNAL SST 1-1/4 SHAFT	1	12558A008	12558A018	12558A008
C5	RING; RET EXTERNAL ST .7874 SHAFT	1	12558A025	--	--
C6*	UPPER SEAL HOUSING	1	22576D010 (x)	22709D010 (x)	22576D010 (x)
C7*	LOWER SEAL HOUSING	1	22638C000 (x)	22710C000 (x)	22853C000 (x)

*Note: Hazardous location pumps require replacement parts be designated with x where noted.

WIRING DIAGRAMS

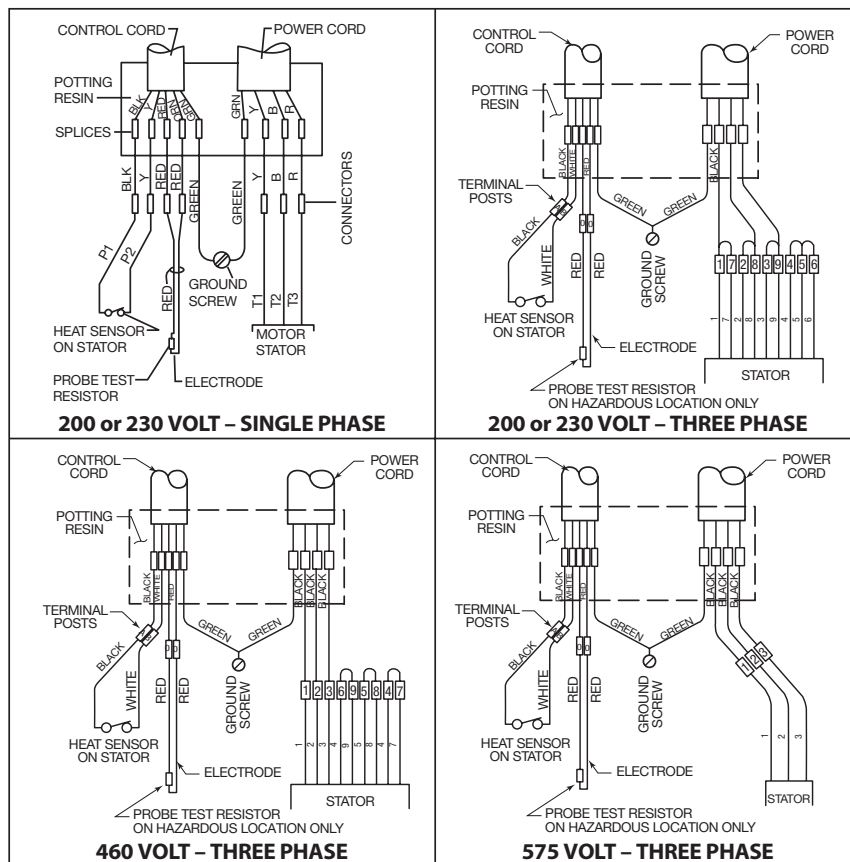

3V/3VX

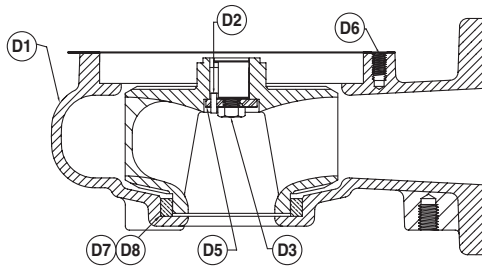

4V/4VX

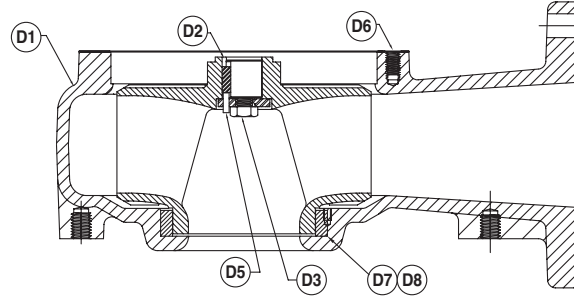

3R/3RX

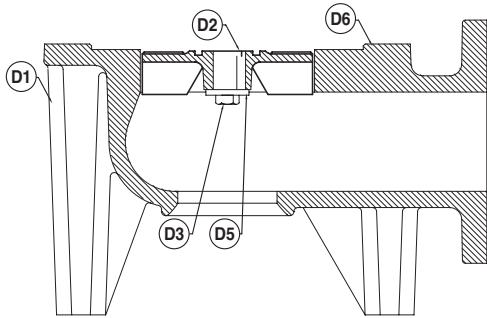

4R/4RX

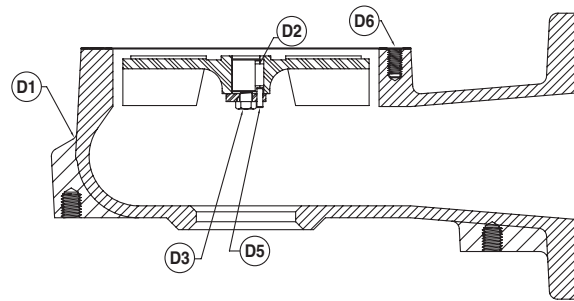

3RH/3RHX

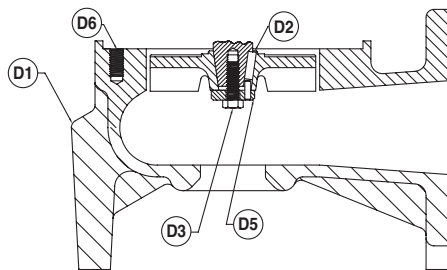

WET END PARTS For use with product built with Regal motor.

3V/3VX

Ref.	Description	Part Number	Qty.
D1	CASE; VOLUTE	22945D050	1
D2	KEY; SQ SST 1/4 x 1/4 13/16	05818A066	1
D3	SCREW; CAP HEX SST 3/8-16 x 1 LG	19103A052	1
D4	SCREW; CAP HEX SST 7/16 x 1-1/4 LG (PG. 12)	23609A002	4
D5	WASHER; RETAINER, W/PIN	19102A006	1
D6	GASKET; VELLUMOID 10-3/8 x 8-7/16 x 1/32	05231A079	1
D7	BRONZE WEAR RING	22945D061A	1
D8	1/4-20 SET SCREW	05013A013	2

4V/4VX

Ref.	Description	Part Number	Qty.
D1	CASE; VOLUTE	22712D000	1
D2	KEY; SQ SST 1/4 x 1/4 13/16	05818A066	1
D3	SCREW; CAP HEX SST 300 1/2-13UNC x 1-1/4 LG	19103A052	1
D4	SCREW; CAP HEX SST 7/16 x 1-1/2 LG (PG. 12)	19102A006	4
D5	WASHER; RETAINER, W/PIN	23609A002	1
D6	GASKET; VELLUMOID 10-3/8 x 8-7/16 x 1/32	05231A079	1
D7	BRONZE WEAR RING	22712D001A	1
D8	1/4-20 SET SCREW	05013A013	2

3R/3RX

Ref.	Description	Part Number	Qty.
D1	CASE; VOLUTE 2 POLE	27705D010	1
	CASE; VOLUTE 4 POLE	27706D010	1
D2	KEY; SQ SST 1/4 x 1/4 11/16	05818A074	1
D3	SCREW; CAP HEX SST 3/8-16 x 1 LG	19101A010	1
D4	SCREW; CAP HEX SST 7/16 x 1-1/2 LG (PG. 12)	19102A006	4
D5	WASHER; RETAINER, W/PIN	23609A001	1
D6	GASKET; VELLUMOID 10-3/8 x 8-7/16 x 1/32	05231A079	1

4R/4RX

Ref.	Description	Part Number	Qty.
D1	CASE; VOLUTE	22854D000	1
D2	KEY; SQ SST 1/4 x 1/4 11/16	05818A074	1
D3	SCREW; CAP HEX SST 3/8-16 x 1 LG	19101A010	1
D4	SCREW; CAP HEX SST 7/16 x 1-1/2 LG (PG. 12)	19102A006	4
D5	WASHER; RETAINER, W/PIN	23609A001	1
D6	GASKET; VELLUMOID 10-3/8 x 8-7/16 x 1/32	05231A079	1

3RH/3RHX

Ref.	Description	Part Number	Qty.
D1	CASE; VOLUTE	25984D000	1
D2	KEY; SQ SST 1/4 x 1/4 13/16	05818A066	1
D3	SCREW; CAP HEX SST 3/8-16 x 1 LG	19101A010	1
D4	SCREW; CAP HEX SST 7/16 x 1-1/4 LG (PG. 12)	19102A020	4
D5	WASHER; RETAINER, W/PIN	23609A001	1
D6	GASKET; VELLUMOID 10-3/8 x 8-7/16 x 1/32	-	1

IMPELLER CHART

Pump	RPM	HP	Trim	Impeller
3V/3VX10M4-21	1750	1	5.0	22946C565
3V/3VX10M4-03	1750	1	5.0	22946C565
3V/3VX10M4-23	1750	1	5.0	22946C565
3V/3VX10M4-43	1750	1	5.0	22946C565
3V/3VX10M4-53	1750	1	5.0	22946C565
3V/3VX15M4-21	1750	1.5	5.5	22946C561
3V/3VX15M4-03	1750	1.5	5.5	22946C561
3V/3VX15M4-23	1750	1.5	5.5	22946C561
3V/3VX15M4-43	1750	1.5	5.5	22946C561
3V/3VX15M4-53	1750	1.5	5.5	22946C561
3V/3VX20M4-21	1750	2	5.75	22946C559
3V/3VX20M4-03	1750	2	5.75	22946C559
3V/3VX20M4-23	1750	2	5.75	22946C559
3V/3VX20M4-43	1750	2	5.75	22946C559
3V/3VX20M4-53	1750	2	5.75	22946C559
3V/3VX30M4-21	1750	3	6.25	22946C555
3V/3VX30M4-03	1750	3	6.25	22946C555
3V/3VX30M4-23	1750	3	6.25	22946C555
3V/3VX30M4-43	1750	3	6.25	22946C555
3V/3VX30M4-53	1750	3	6.25	22946C555
3V/3VX50M4-21	1750	5	6.75	22946C551
3V/3VX50M4-03	1750	5	6.75	22946C551
3V/3VX50M4-23	1750	5	6.75	22946C551
3V/3VX50M4-43	1750	5	6.75	22946C551
3V/3VX50M4-53	1750	5	6.75	22946C551

Pump	RPM	HP	Trim	Impeller
3RH/3RHX30M2-01	3450	3	3.50	25983B501
3RH/3RHX30M2-21	3450	3	3.50	25983B501
3RH/3RHX30M2-03	3450	3	3.50	25983B501
3RH/3RHX30M2-23	3450	3	3.50	25983B501
3RH/3RHX30M2-43	3450	3	3.50	25983B501
3RH/3RHX30M2-53	3450	3	3.50	25983B501
3RH/3RHX50M2-01	3450	5	4.25	25983B507
3RH/3RHX50M2-21	3450	5	4.25	25983B507
3RH/3RHX50M2-03	3450	5	4.25	25983B507
3RH/3RHX50M2-23	3450	5	4.25	25983B507
3RH/3RHX50M2-43	3450	5	4.25	25983B507
3RH/3RHX50M2-53	3450	5	4.25	25983B507
3RH/3RHX75M2-03	3450	7.5	4.75	25983B511
3RH/3RHX75M2-23	3450	7.5	4.75	25983B511
3RH/3RHX75M2-43	3450	7.5	4.75	25983B511
3RH/3RHX75M2-53	3450	7.5	4.75	25983B511

Note: Standard non-overloading impeller diameters shown.

Pump	RPM	HP	Trim	Impeller
3R/3RX30M2-01	3450	3	3.75	27708B012
3R/3RX30M2-21	3450	3	3.75	27708B012
3R/3RX30M2-03	3450	3	3.75	27708B012
3R/3RX30M2-23	3450	3	3.75	27708B012
3R/3RX30M2-43	3450	3	3.75	27708B012
3R/3RX30M2-53	3450	3	4.75	27708B010
3R/3RX50M2-21	3450	5	4.75	27708B010
3R/3RX50M2-03	3450	5	4.75	27708B010
3R/3RX50M2-23	3450	5	4.75	27708B010
3R/3RX50M2-43	3450	5	4.75	27708B010
3R/3RX50M2-53	3450	5	4.75	27708B010
3R/3RX20M4-01	1750	2	5.25	22855C519
3R/3RX20M4-21	1750	2	5.25	22855C519
3R/3RX20M4-03	1750	2	5.25	22855C519
3R/3RX20M4-23	1750	2	5.25	22855C519
3R/3RX20M4-43	1750	2	5.25	22855C519
3R/3RX20M4-53	1750	2	5.25	22855C519
3R/3RX30M4-01	1750	3	6	22855C517
3R/3RX30M4-21	1750	3	6	22855C517
3R/3RX30M4-03	1750	3	6	22855C517
3R/3RX30M4-23	1750	3	6	22855C517
3R/3RX30M4-43	1750	3	6	22855C517
3R/3RX30M4-53	1750	3	6	22855C517
3R/3RX50M4-21	1750	5	6.75	22855C511
3R/3RX50M4-03	1750	5	6.75	22855C511
3R/3RX50M4-23	1750	5	6.75	22855C511
3R/3RX50M4-43	1750	5	6.75	22855C511
3R/3RX50M4-53	1750	5	6.75	22855C511

Pump	RPM	HP	Trim	Impeller
4R/4RX30M4-21	1750	3	6.0	22855C517
4R/4RX30M4-03	1750	3	6.0	22855C517
4R/4RX30M4-23	1750	3	6.0	22855C517
4R/4RX30M4-43	1750	3	6.0	22855C517
4R/4RX30M4-53	1750	3	6.0	22855C517
4R/4RX50M4-21	1750	5	6.75	22855C511
4R/4RX50M4-03	1750	5	6.75	22855C511
4R/4RX50M4-23	1750	5	6.75	22855C511
4R/4RX50M4-43	1750	5	6.75	22855C511
4R/4RX50M4-53	1750	5	6.75	22855C511
4R/4RX75M4-03	1750	7.5	7.5	22855C505
4R/4RX75M4-23	1750	7.5	7.5	22855C505
4R/4RX75M4-43	1750	7.5	7.5	22855C505
4R/4RX75M4-53	1750	7.5	7.5	22855C505

4R/4RX10M6-21	1150	1	6.0	22855C517
4R/4RX10M6-03	1150	1	6.0	22855C517
4R/4RX10M6-23	1150	1	6.0	22855C517
4R/4RX10M6-43	1150	1	6.0	22855C517
4R/4RX10M6-53	1150	1	6.0	22855C517
4R/4RX15M6-21	1150	1.5	6.75	22855C511
4R/4RX15M6-03	1150	1.5	6.75	22855C511
4R/4RX15M6-23	1150	1.5	6.75	22855C511
4R/4RX15M6-43	1150	1.5	6.75	22855C511
4R/4RX15M6-53	1150	1.5	6.75	22855C511
4R/4RX20M6-21	1150	2	7.25	22855C507
4R/4RX20M6-03	1150	2	7.25	22855C507
4R/4RX20M6-23	1150	2	7.25	22855C507
4R/4RX20M6-43	1150	2	7.25	22855C507
4R/4RX20M6-53	1150	2	7.25	22855C507

Pump	RPM	HP	Trim	Impeller
4V/4VX30M4-21	1750	3	6.0	22711C518
4V/4VX30M4-03	1750	3	6.0	22711C518
4V/4VX30M4-23	1750	3	6.0	22711C518
4V/4VX30M4-43	1750	3	6.0	22711C518
4V/4VX30M4-53	1750	3	6.0	22711C518
4V/4VX50M4-21	1750	5	7.0	22711C510
4V/4VX50M4-03	1750	5	7.0	22711C510
4V/4VX50M4-23	1750	5	7.0	22711C510
4V/4VX50M4-43	1750	5	7.0	22711C510
4V/4VX50M4-53	1750	5	7.0	22711C510
4V/4VX75M4-03	1750	7.5	7.5	22711C506
4V/4VX75M4-23	1750	7.5	7.5	22711C506
4V/4VX75M4-43	1750	7.5	7.5	22711C506
4V/4VX75M4-53	1750	7.5	7.5	22711C506

4V/4VX10M6-21	1150	1	6.0	22711C518
4V/4VX10M6-03	1150	1	6.0	22711C518
4V/4VX10M6-23	1150	1	6.0	22711C518
4V/4VX10M6-43	1150	1	6.0	22711C518
4V/4VX10M6-53	1150	1	6.0	22711C518
4V/4VX15M6-21	1150	1.5	7.0	22711C510
4V/4VX15M6-03	1150	1.5	7.0	22711C510
4V/4VX15M6-23	1150	1.5	7.0	22711C510
4V/4VX15M6-43	1150	1.5	7.0	22711C510
4V/4VX15M6-53	1150	1.5	7.0	22711C510
4V/4VX20M6-21	1150	2	7.5	22711C506
4V/4VX20M6-03	1150	2	7.5	22711C506
4V/4VX20M6-23	1150	2	7.5	22711C506
4V/4VX20M6-43	1150	2	7.5	22711C506
4V/4VX20M6-53	1150	2	7.5	22711C506

STANDARD LIMITED WARRANTY

Pentair Myers® warrants its products against defects in material and workmanship for a period of 12 months from the date of shipment from Pentair Myers or 18 months from the manufacturing date, whichever occurs first – provided that such products are used in compliance with the requirements of the Pentair Myers catalog and technical manuals for use in pumping raw sewage, municipal wastewater or similar, abrasive-free, noncorrosive liquids.

During the warranty period and subject to the conditions set forth, Pentair Myers, at its discretion, will repair or replace to the original user, the parts that prove defective in materials and workmanship. Pentair Myers reserves the right to change or improve its products or any portions thereof without being obligated to provide such a change or improvement for prior sold and/or shipped units.

Start-up reports and electrical schematics may be required to support warranty claims. Submit at the time of start-up through the Pentair Myers website: <http://forms.pentairliterature.com/startupform/startupform.asp?type=m>. Warranty is effective only if Pentair Myers authorized control panels are used. All seal fail and heat sensing devices must be hooked up, functional and monitored or this warranty will be void. Pentair Myers will cover only the lower seal and labor thereof for all dual seal pumps. Under no circumstance will Pentair Myers be responsible for the cost of field labor, travel expenses, rented equipment, removal/reinstallation costs or freight expenses to and from the factory or an authorized Pentair Myers service facility.

This limited warranty will not apply: (a) to defects or malfunctions resulting from failure to properly install, operate or maintain the unit in accordance with the printed instructions provided; (b) to failures resulting from abuse, accident or negligence; (c) to normal maintenance services and parts used in connection with such service; (d) to units that are not installed in accordance with applicable local codes, ordinances and good trade practices; (e) if the unit is moved from its original installation location; (f) if unit is used for purposes other than for what it is designed and manufactured; (g) to any unit that has been repaired or altered by anyone other than Pentair Myers or an authorized Pentair Myers service provider; (h) to any unit that has been repaired using non factory specified/OEM parts.

Warranty Exclusions: PENTAIR MYERS MAKES NO EXPRESS OR IMPLIED WARRANTIES THAT EXTEND BEYOND THE DESCRIPTION ON THE FACE HEREOF. PENTAIR MYERS SPECIFICALLY DISCLAIMS THE IMPLIED WARRANTIES OF MERCHANTABILITY AND FITNESS FOR ANY PARTICULAR PURPOSE.

Liability Limitation: IN NO EVENT SHALL PENTAIR MYERS BE LIABLE OR RESPONSIBLE FOR CONSEQUENTIAL, INCIDENTAL OR SPECIAL DAMAGES RESULTING FROM OR RELATED IN ANY MANNER TO ANY PENTAIR MYERS PRODUCT OR PARTS THEREOF. PERSONAL INJURY AND/OR PROPERTY DAMAGE MAY RESULT FROM IMPROPER INSTALLATION. PENTAIR MYERS DISCLAIMS ALL LIABILITY, INCLUDING LIABILITY UNDER THIS WARRANTY, FOR IMPROPER INSTALLATION. PENTAIR MYERS RECOMMENDS INSTALLATION BY PROFESSIONALS.

Some states do not permit some or all of the above warranty limitations or the exclusion or limitation of incidental or consequential damages and therefore such limitations may not apply to you. No warranties or representations at any time made by any representatives of Pentair Myers shall vary or expand the provision hereof.



MYERS®

1101 MYERS PARKWAY
ASHLAND, OHIO, USA 44805
419-289-1144

490 PINEBUSH ROAD, UNIT #4
CAMBRIDGE, ONTARIO, CANADA N1T 0A5
800-363-PUMP

WWW.FEMYERS.COM