

## SERVICE MANUAL Massage chair

**HEC-902** (GENERAL)

**HEC-904** (GENERAL)

MODEL	HEC-902	HEC-904
Power consumption	90 W	130 W
Rated time	30 min	
Timer	[manual]about 15 minutes,[automatic]neck / shoulder about 11 minutes,[upper half of the body]about 13 minutes,[waist]about 13 minutes.	
Dimension	660 mm(width) X 1,000 mm(depth) X 1,030 mm(height) *When not reclined(with foot rest retracted)	
	660 mm(width) X 1,650 mm(depth) X 570 mm(height) *When reclined (with foot rest set horizontally)	
Weight	Approx. 50 kg	Approx. 52 kg
Exterior cloth	Polyester chloride 100 %	
Number of massagings	3 stages 20 times/min., 25 times/min., 30 times/min.	
Number of tappings	3 stages 360 times/min., 480 times/min., 600 times/min.	
Tapping width	3 stages Approx. 70 mm, 100 mm, 130 mm	
Vertical movement speed	One reciprocating motion in approx. 27 sec.	
Backborn stretching width	3 stages Approx. 70 mm, 100 mm, 130 mm	
Massaging ball up/down range	Approx. 600 mm	
Height adjustment of massaging ball.	3 stages	
Leg vibration	Vibration type	
Reclining angle	Approx. 120~170°	
Reclining method	Manual method	Motor-driven type
Accessory	Head cover	

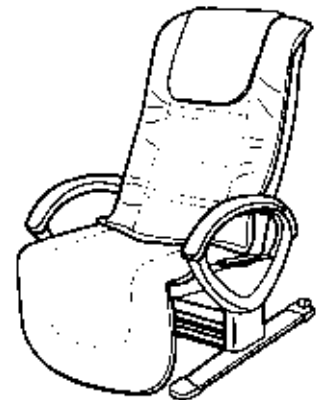

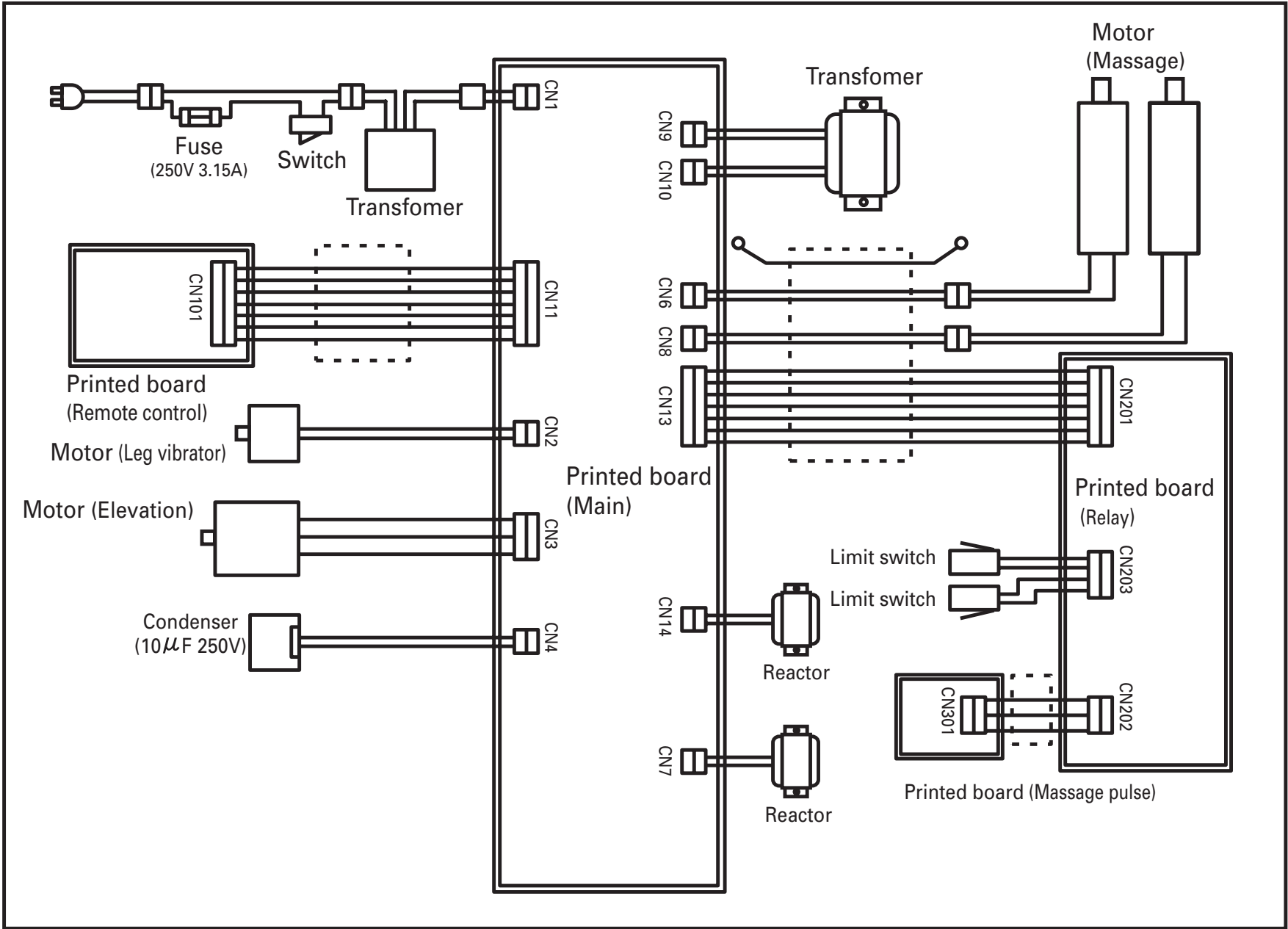

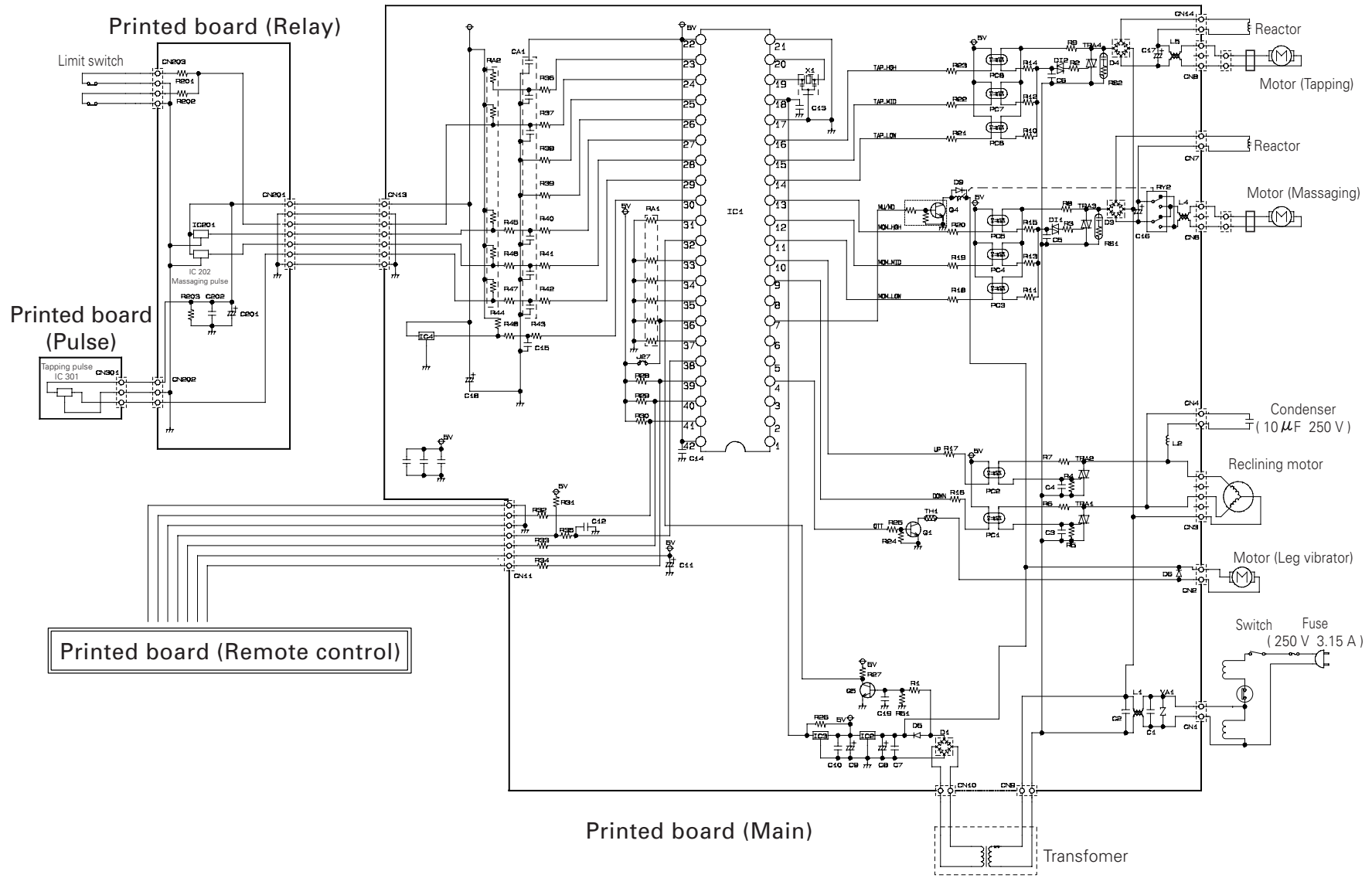

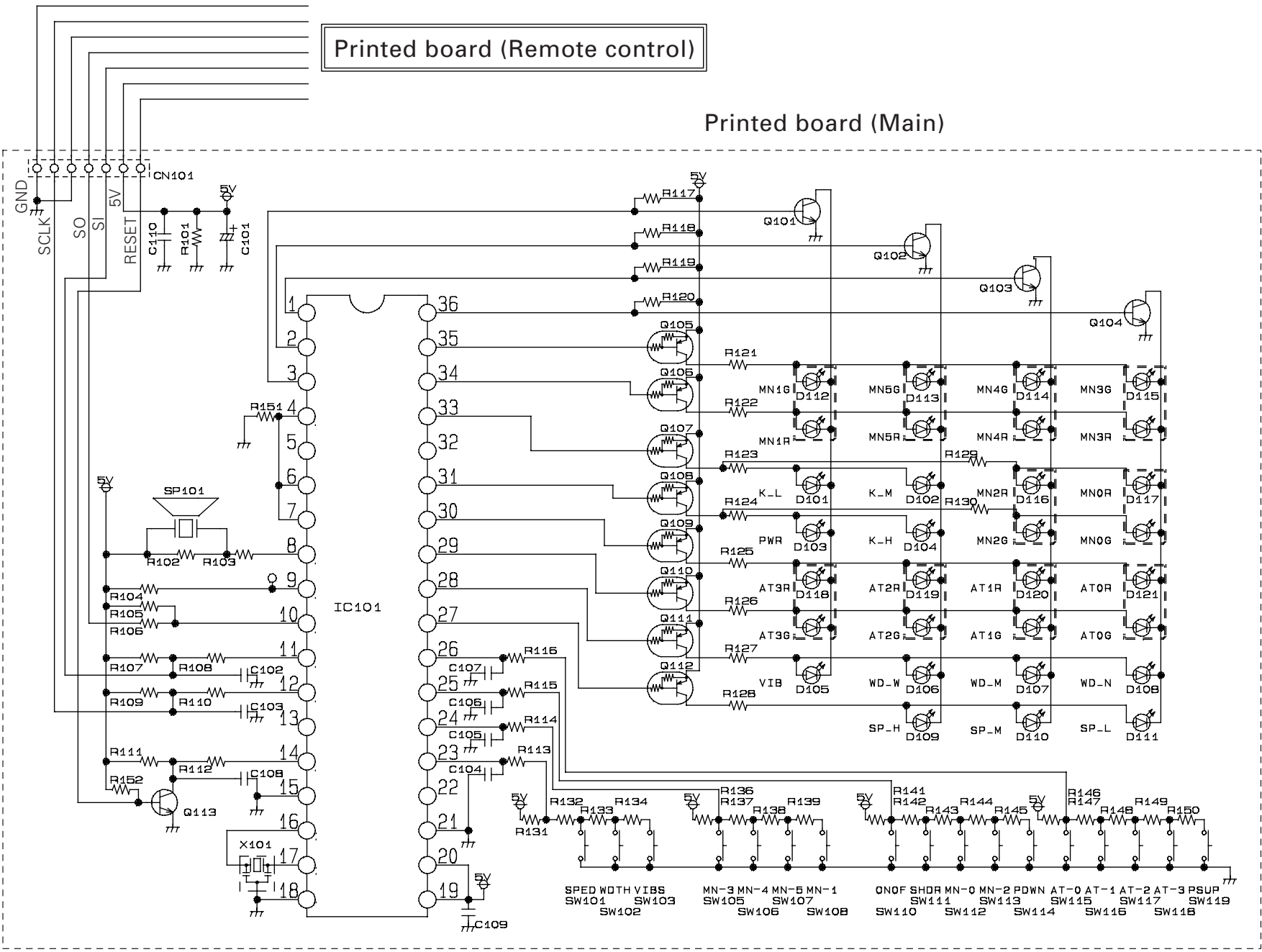

Printed board (Remote control)

Printed board (Main)

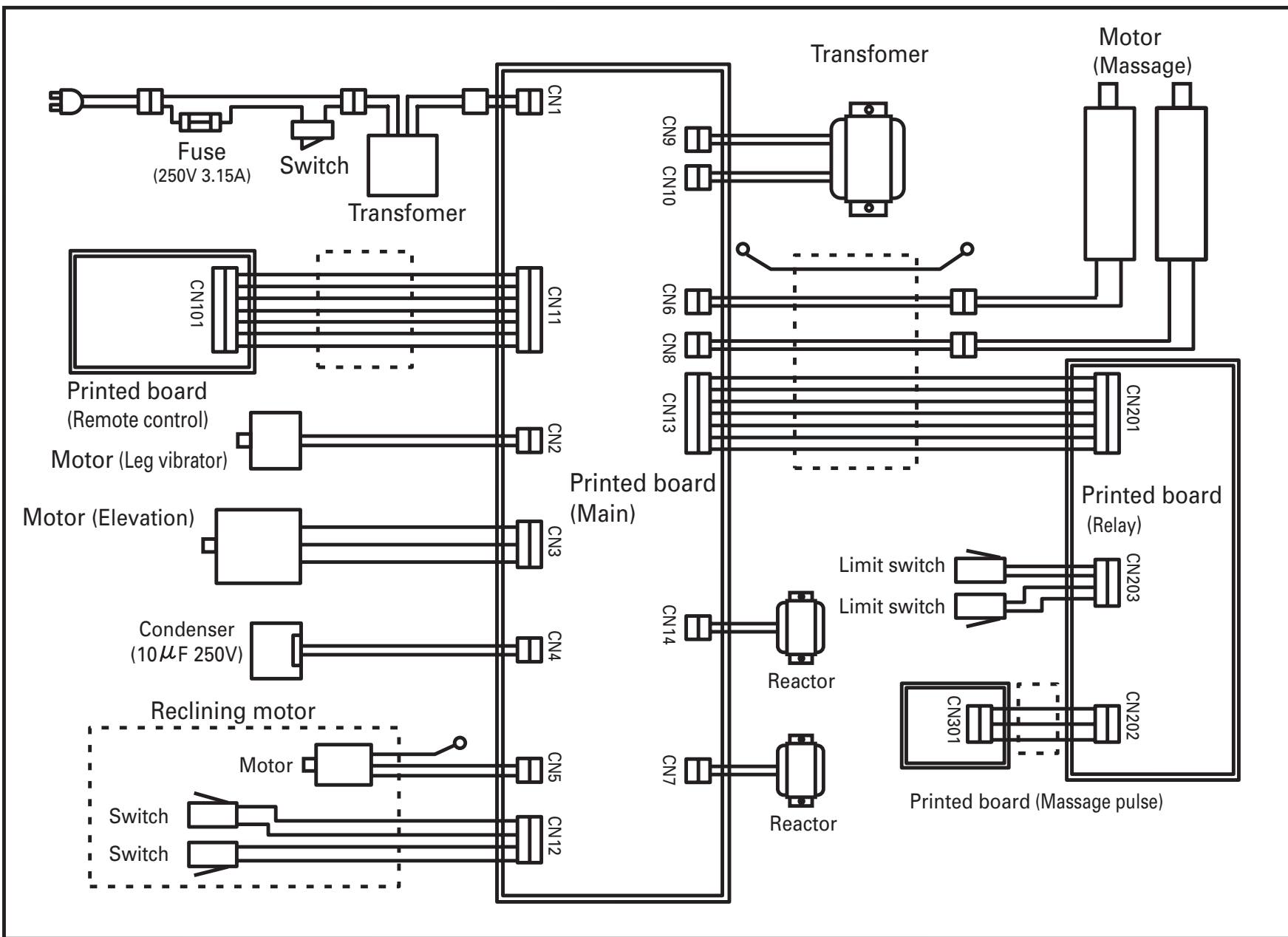

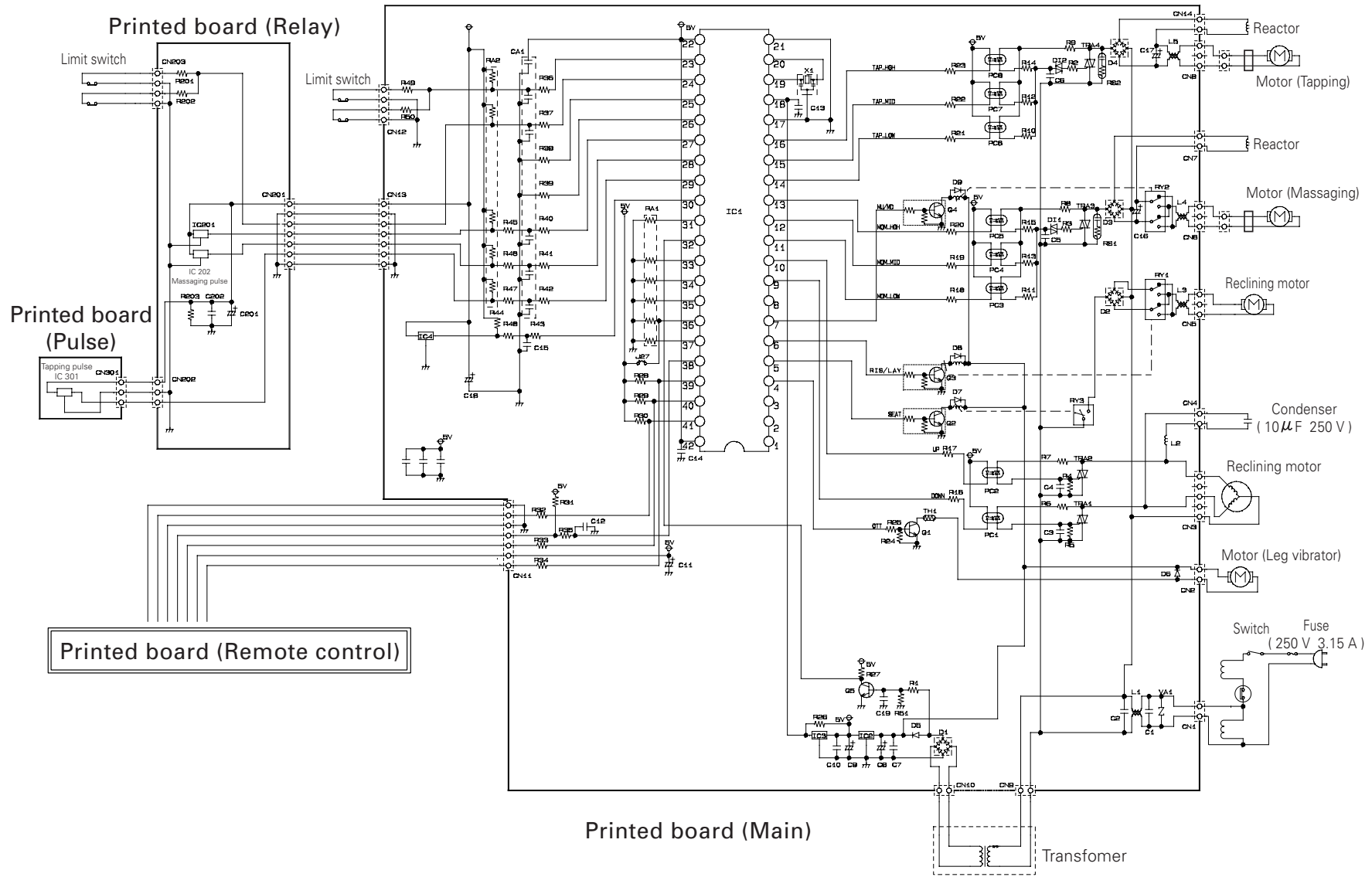

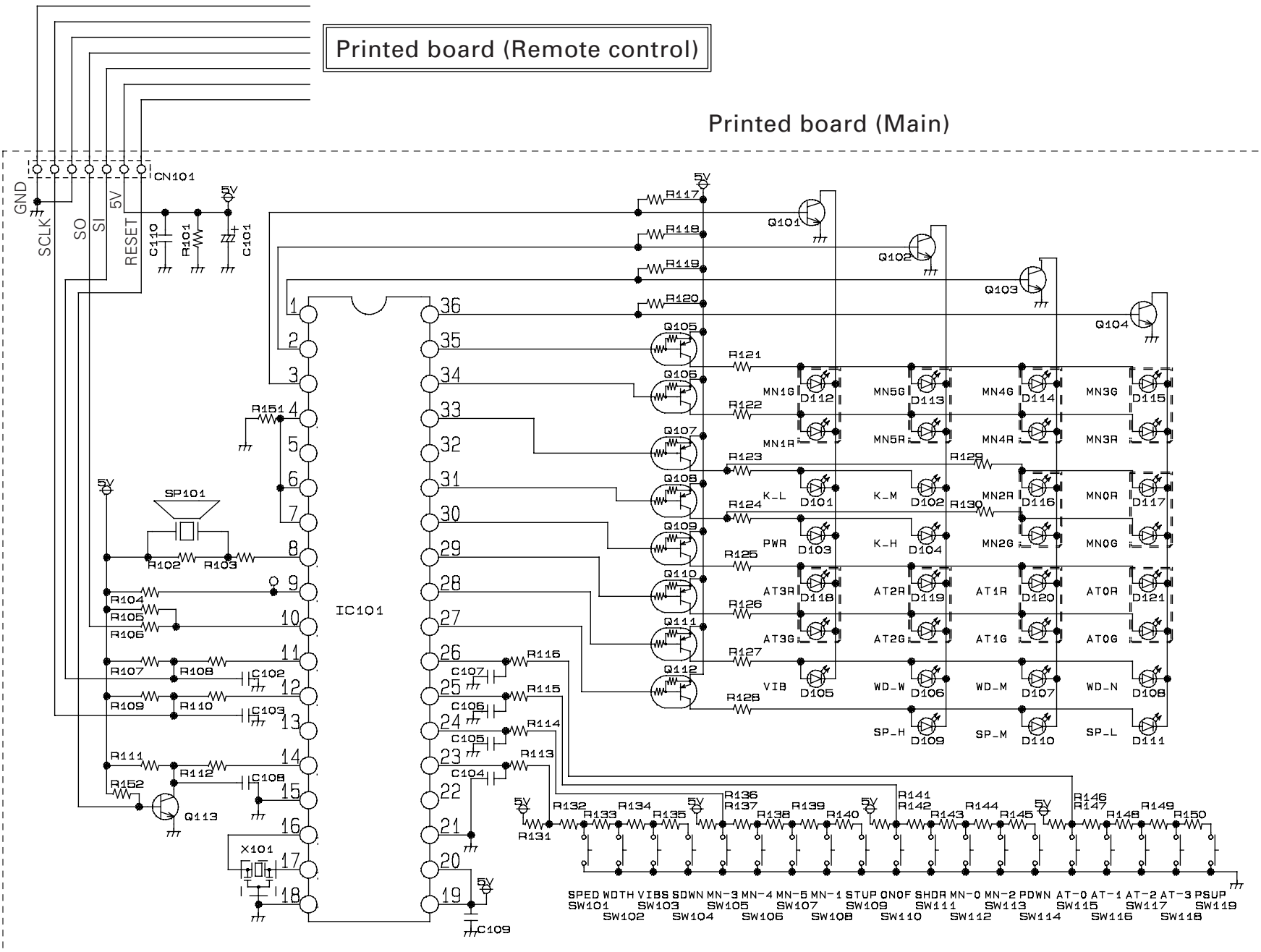

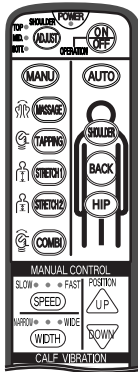

Printed board (Remote control)

Printed board (Main)

Trouble indication pattern	Troubled portion	Trouble phenomenon	Occurrence condition (after power "ON")	Check item	Counteraction method
 <p>Nothing is displayed</p>	Power and remote control relations	Nothing is displayed after the power ON.	Immediate	<ol style="list-style-type: none"> <li>1. Check current fuse (3.15A) for fusion.</li> <li>2. Check Printed board (Main) CN1 output (AC100V).</li> <li>3. Check Printed board (Main) CN9 output (AC100V).</li> <li>4. Check power transformer output CN10 (approx. 12V).</li> <li>5. Check Printed board (main) CN11 and Printed board (remote control) CN101 for connector come-off. Check pins (both No.5 (brown) and No.7 (black), or No.1 (white) and No.2 (red) for come-off.)</li> <li>6. Check the remote control cable for disconnection or shorting. (both brown and black wires or white and red wires)</li> <li>7. When no fault is detected upon checking in Step 1 - 6;</li> </ol>	<p>Replace the current fuse (3.15A).</p> <p>Check the power switch and power cord and transformer for normal conductivity and replace them if necessary upon check. Replace the Printed board (main).</p> <p>Replace the power transformer.</p> <p>Insert the connector and pins.</p> <p>Replace the remote control cable.</p> <p>Replace the Printed board (remote control) or Printed board (main).</p>
 <p>The power lamp, and message red lamp, tapping red lamps, stretch 1 red lamps, stretch 2 red lamps, combi red lamps lighting.</p>	Remote control relations	Trouble described left is displayed immediately or 3 seconds after the power switch is turned ON.	Immediately or 3 seconds later	<ol style="list-style-type: none"> <li>1. Check the Printed board (main) CN11 and Printed board (remote control) CN101 connector pins for come-off. (Pin No. 3 (blue), 4 (yellow), and 6 (orange))</li> <li>2. Check the remote control cable for disconnection or shorting. (Blue, yellow and orange wires)</li> <li>3. When no fault is detected upon above check;</li> </ol>	<p>Insert the connector pins.</p> <p>Replace the remote control cable.</p> <p>Replace the Printed board (remote control) or Printed board (main).</p>

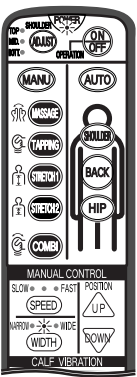

Trouble indication pattern	Troubled portion	Trouble phenomenon	Occurrence condition (after power "ON")	Check item	Counteraction method	
 <p>The power lamp, the center of the width lamp and massage red lamp, tapping red lamps, stretch 1 red lamps, stretch 2 red lamps, combi red lamps lighting.</p>	Massage motor relations	Trouble described left is displayed 15 seconds after the power is turned ON or "MESSAGE" is selected.	Massaging failure	15 seconds later or 15 seconds after massaging motion	<ol style="list-style-type: none"> <li>1. Check the Printed board (main) CN6 and CN7 and massage motor junction connector for come-off.</li> <li>2. Check the harness between the Printed board (main) CN6 and massage motor junction connector for disconnection.</li> </ol>	<p>Insert the connector.</p> <p>Replace the main harness</p>
				during massage	<ol style="list-style-type: none"> <li>3. Check the Printed board (main) CN6 output (approx. DC57 - 100V).</li> </ol>	<p>If output → Replace the massage motor. If no output → Replace the Printed board (main).</p>
		Massaging mode remains unchanged.	15 seconds later or 15 seconds after massaging motion	<ol style="list-style-type: none"> <li>4. Check the Printed board (relay) CN201 connector and Printed board (main) CN13 connector for come-off of each lead wire pin (Pin No. 3 (brown), 4 (yellow) and 7 (white).)</li> <li>5. Check the main harness CN201 to CN13 line for disconnection or shorting.</li> <li>6. Check the massaging "POSITION" and "ROTATION" magnets for their mounting direction and fall-down.</li> <li>7. Check the Printed board (relay) IC 201 and IC 202 for inclination.</li> <li>8. Check the belt (MOMI) for dislocation and cut-off.</li> </ol>	<p>Insert each lead wire pin.</p> <p>Replace the main harness</p> <p>Mount the magnet in normal condition.</p> <p>Correct the tilted condition or replace the Printed board (relay).</p> <p>Mount or replace the belt (MOMI).</p>	
		Message motor running		<ol style="list-style-type: none"> <li>9. When no fault is detected upon checking in the Step 1 - 8;</li> </ol>	<p>Replace the Printed board (relay) or the Printed board (main).</p>	

Trouble indication pattern	Troubled portion	Trouble phenomenon	Occurrence condition (after power "ON")	Check item	Counteraction method	
 <p>The power lamp, the center of the width lamp and massage red lamp, tapping red lamps, stretch 1 red lamps, stretch 2 red lamps, combi red lamps lighting.</p>	Tapping motor relations	Trouble described left is displayed 15 seconds after the power is turned ON or "TAPPING" is selected.	Tapping failure	15 seconds later or 15 seconds after tapping motion	<ol style="list-style-type: none"> <li>1. Check the Printed board (main) CN8 and CN14 and the tapping motor junction connector for come-off.</li> <li>2. Check the Printed board (main) CN8 to tapping motor connector harness for disconnection.</li> </ol>	<p>Insert the connector.</p> <p>Replace the main harness</p>
				during tapping	<ol style="list-style-type: none"> <li>3. Check the Printed board (main) CN8 output (approx. DC57 ~ 100V).</li> </ol>	<p>If output → Replace The tapping motor. If no output → Replace the Printed board (main).</p>
			Tapping mode remains unchanged.	15 seconds after tapping motion	<ol style="list-style-type: none"> <li>4. Check the Printed board (relay) CN202 connector for come-off and pins for come-off.</li> <li>5. Check the Printed board (pulse) CN301 connector for come-off and pins for come-off.</li> <li>6. Check the Printed board (relay) CN201 and Printed board (main) CN13 connectors for come-off of each lead wire pin (No.2).</li> <li>7. Check the junction harness (CN202 - CN301 circuit) for disconnection or shorting.</li> <li>8. Check the tapping magnet for its mounting direction and fall-down.</li> <li>9. Check the Printed board (pulse) IC 301 for inclination.</li> <li>10. Check the belt (TATAKI) for dislocation and cut-off.</li> </ol>	<p>Insert the connector and pins.</p> <p>Insert the connector and pins.</p> <p>Insert each lead wire pin.</p> <p>Replace the junction harness</p> <p>Mount the magnet in normal condition.</p> <p>Correct the tilted condition or replace the Printed board (pulse). Mount or replace the belt (TATAKI).</p>
			Tapping motor running		<ol style="list-style-type: none"> <li>11. When no fault is detected upon check in Step 1 - Step 10;</li> </ol>	<p>Replace the Printed board (relay or pulse) or the Printed board (main).</p>

Trouble indication pattern	Troubled portion	Trouble phenomenon	Occurrence condition (after power "ON")	Check item	Counteraction method
 <p>The power lamp, the center of the speed lamp, and massage red lamp, tapping red lamps, stretch 1 red lamps, stretch 2 red lamps, combi red lamps lighting.</p>	Elevation motor relations	Elevation failure	During elevation or 30 seconds later	<ol style="list-style-type: none"> <li>1. Check the Printed board (main) CN3 and CN4 connectors for come-off and pins for come-off.</li> <li>2. Pull out CN3 on the Printed board (main) and check for the red pin to white pin output and blue pin to white pin output of the Printed board side CN3 (to be approx. AC100V respectively). *For checking, turn ON the massager from the remote control and keep either vertical adjust button "UP" or "DOWN" as pressed.</li> </ol>	Insert the connector and pins.  If output from the both ↓ Replace the elevation motor.  If either or neither from the both ↓ Replace the Printed board (main).
		Trouble described left is displayed 3 seconds after the power is turned ON. (The upward motion is effected immediately only after the power is turned ON.)	3 seconds later	<ol style="list-style-type: none"> <li>3. Check the Printed board (relay) CN201 connector for come-off.</li> <li>4. Check the Printed board (relay) CN203 connector for come-off.</li> <li>5. Check the Printed board (main) CN13 connector for come-off.</li> <li>6. Check the Printed board (relay) CN201 connector and Printed board (main) CN13 connector for come-off of each lead wire pin thereof (both No.1 (black) and No.6 (red), or No.5 (blue).</li> <li>7. Check the main harness (CN201 to CN13) for disconnection or shorting. (No.1 (black), No.6 (red) and No.5 (blue) )</li> </ol>	Insert the connector.  Insert the connector.  Insert the connector.  Insert each lead wire pin.   Replace the main harness.

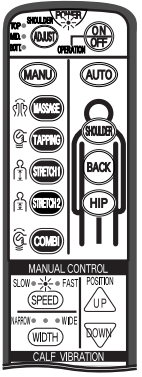
Trouble indication pattern	Troubled portion	Trouble phenomenon	Occurrence condition (after power "ON")	Check item	Counteraction method
 <p>The power lamp, the center of the speed lamp, and massage red lamp, tapping red lamps, stretch 1 red lamps, stretch 2 red lamps, combi red lamps lighting.</p>	Elevation motor relations	Trouble described left is displayed 3 seconds after the power is turned ON or after starting elevation. (Start elevation.)	3 seconds later or 30 seconds after elevation	8. Check the upper and lower limit switches for trouble (micro switch and harness). < Under normal condition > 1. Stop at the highest position (upper limit switch ON, lower limit switch OFF) Pin 1 - 2 (white - red) of CN203 connector $\infty$ (open) Pin 3 - 4 (green - yellow) of CN203 0 $\Omega$ (close) 2. Stop at the middle position. (Upper limit switch OFF, lower limit switch OFF) Pin 1 - 2 (white - red) of CN203 connector 0 $\Omega$ (close) Pin 3 - 4 (green - yellow) of CN203 0 $\Omega$ (close) 3. Stop at the lowest position. (Upper limit switch OFF, lower limit switch ON) Pin 1 - 2 (white - red) of CN203 connector 0 $\Omega$ (close) Pin 3 - 4 (green - yellow) of CN203 connector $\infty$ (open)	Replace the connector ass'y (upper and lower limit switches).
		When "STRETCH 2" mode is selected, "STRETCH 1" motion is effected and trouble described left is displayed.	30 seconds after elevation	9. Check the elevation magnet for the mounting direction and fall-down. 10. Check the Printed board (main) IC4 for tilt.	Mount the magnet in normal condition. Correct the tilted condition or replace the Printed board (main).
		Trouble described left is displayed with no elevating motion. (The elevation motor running)		11. Check the belt (ROLLING) for dislocation and cut-off.	Mount or replace the belt (ROLLING).
			12. When no fault is detected upon check in Step 1 ~ 11;	Replace the Printed board (relay or pulse) or the Printed board (main).	

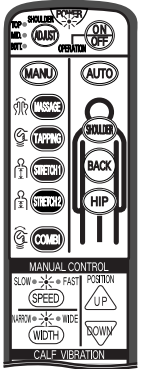
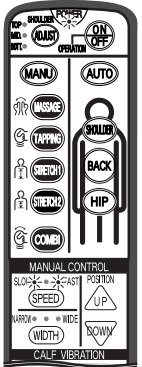
Trouble indication pattern	Troubled portion	Trouble phenomenon	Occurrence condition (after power "ON")	Check item	Counteraction method
 <p>The power lamp, the center of the speed lamp, the center of the width lamp and massage red lamp, tapping red lamps, stretch 1 red lamps, stretch 2 red lamps, combi red lamps lighting.</p>	Motorized reclining relations (HEC-904 only)	Trouble described left is displayed with no reclining motion.	When the motorized reclining operation is effected normally;	1. Check the Printed board (main) CN5 connector and pins for come-off. 2. Check the Printed board (main) CN5 output (to be approx. DC90V).	Insert the connector and pins. If output, → Replace the reclining motor. If no output → Replace the Printed board (main).
		Trouble described left is displayed three minutes after the power ON.	3 seconds later	3. Check the Printed board (main) CN12 connector for come-off.	Insert the connector.
				4. Pull out the Printed board (main) CN12 connector and check whether the current is across No.1 to No.2 pin and No.3 to No.4 pin of the motorized recliner side CN12 connector.	When the both are ∞ (open); ↓ Replace the reclining motor.
			3 seconds later	5. Pull out the Printed board (main) CN5 connector for shorting No.1 to No.2 circuit of CN12. Turn ON the power switch after shorting Pin No. 3 to 4, to check whether trouble is displayed or not.	occur → Replace the Printed board (main). No occur → Replace the reclining motor.
				6. When no fault is detected upon check in Step 1 - 5;	Replace the Printed board (main).
			Other	Trouble described left is displayed.	No
 <p>The power lamp, the both edges of the speed lamp, and massage red lamp, tapping red lamps, stretch 1 red lamps, stretch 2 red lamps, combi red lamps lighting.</p>					

Trouble indication pattern	Troubled portion	Trouble phenomenon	Occurrence condition (after power "ON")	Check item	Counteraction method
No trouble is displayed.	Leg vibrator	Leg vibrator fails to start.	Leg vibrator "ON"	1. Check that Leg vibrator lamp on the remote control is ON.  2. Check the Printed board (main) CN2 output (to be approx. DC12V).	If the lamp OFF ▼ Check and replace the Printed board (remote control).  If output ▶ Replace the cushion (footrest). If no output ▶ Replace the Printed board (main).
Various	Remote control relations	Trouble is displayed (motion stop) from time to time.	Each function in running	1. Start massaging in "AUTO" mod and lightly pull the remote control cord to check whether massaging motion stops or trouble is displayed.	Replace the remote control.

( ON-Printed-board Connectors Configuration Drawing )

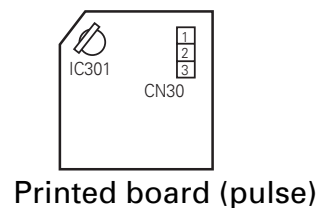
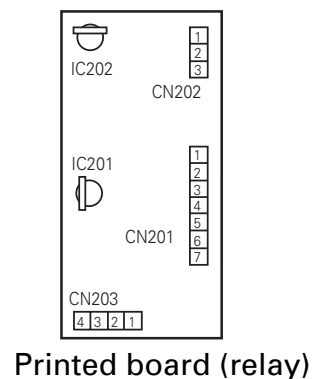
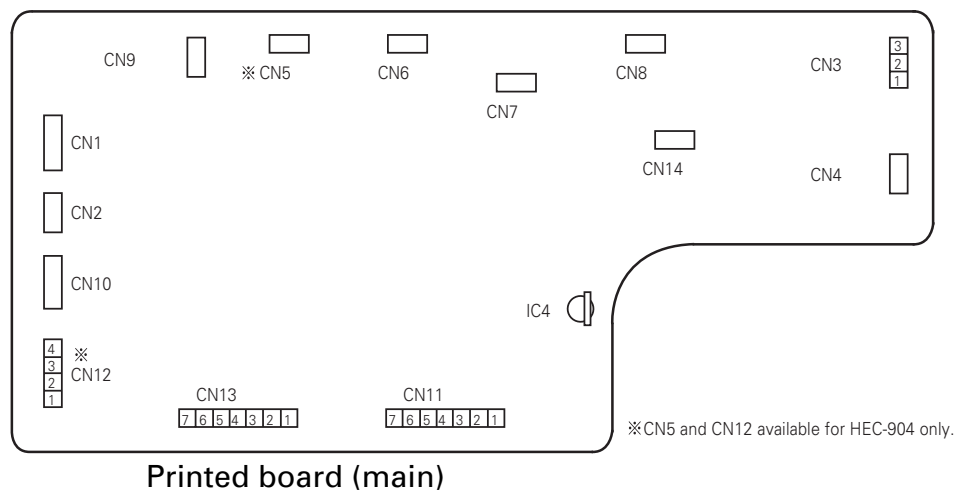

The back rest can recline steplessly up to 170 degree maximum by operating "RECLINING" switch on the remote control.

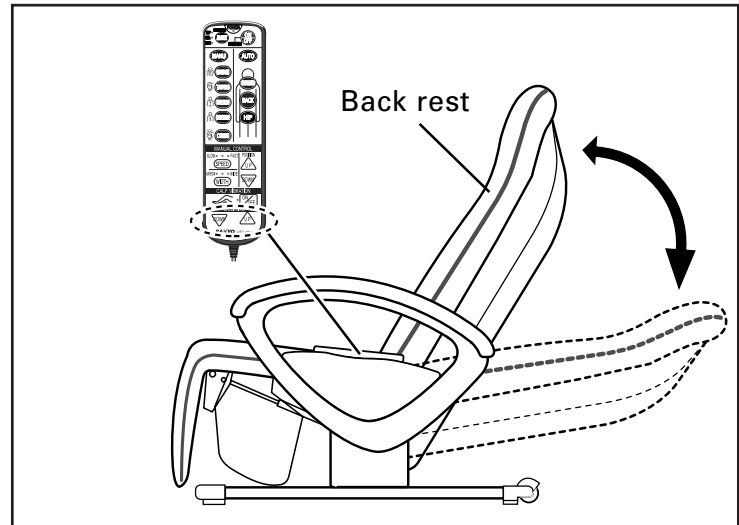

### Motorized reclining operation

1. The reclining motor rotates both clockwise and counterclockwise to make the cylinder stroke length adjustable.
2. The cylinder stroke length is made shorter simultaneously with startup of the reclining motor, so that the backrest is pulled and reclines from the frame supporting center by the cylinder.

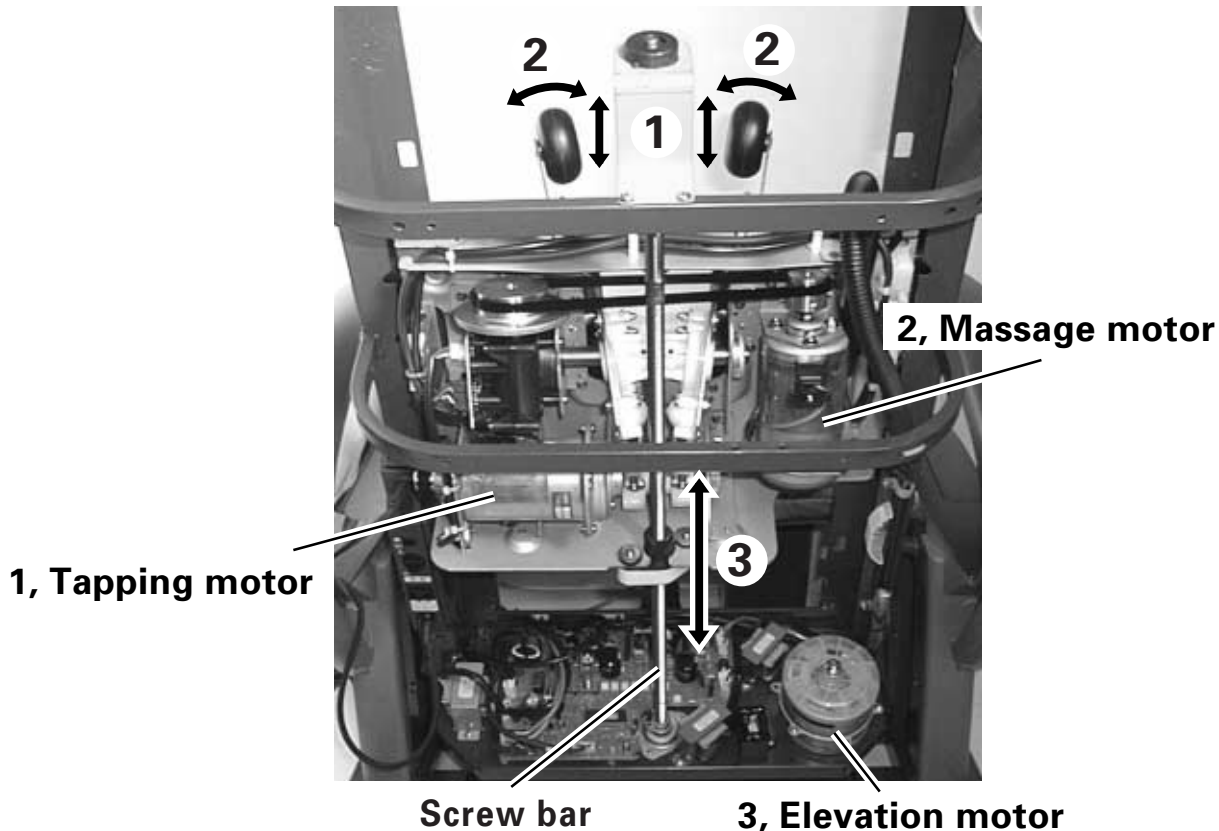
**1, Tapping motor**

This motor rotates to move the massage balls upward and downward alternately via the driving belt coupled to the motor.

(The motor revolutions is adjustable in three steps so that the patting frequency can be changed over to approximately 360, 480 and 600 cycles/minute.)

**2, Massage motor**

This motor rotates to move the massage balls crosswise via the driving belt and gear box coupled to the motor.

(The motor revolutions is adjustable in three steps so that the massaging frequency can be changed over to approximately 20, 25 and 30 cycles/minute.)

(When patting and stretching the backbone line, the massage ball position (ball moving range) can be changed over in three steps after starting the patting motor.)

**3, Elevation motor**

This motor rotates to transmit its rotating torque to the threaded rod via the driving belt, whereby the massage unit is moved upward and downward.

(This motor rotates clockwise and counterclockwise to thereby move the massage unit upward and downward.)

**Tapping-massaging**

You can enjoy the good comfort that you can not do by hand tapping-massage, by starting both the tapping motor and the massage motor simultaneously.

**I-shaped tapping - Z-shaped massaging**

Massaging same portion can be prevented by moving minutely the massage balls upward and downward by starting the elevation motor while running the tapping motor for tapping operation or the massage motor for massaging operation.



## Replacement procedure

HEC-902 (GENERAL)

HEC-904 (GENERAL)

### (1) How to remove the rear cover

1. Unscrew four fixing screws to remove the rear cover. Fig.1

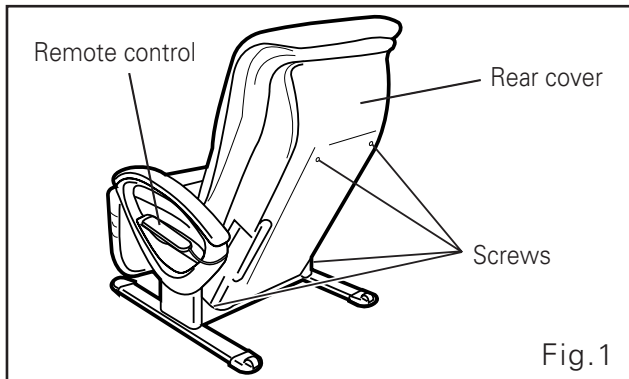

### (2) Replacement of the printed board (main)

1. Unscrew three fixing screws to remove the cover (the printed board, main). Photo.2

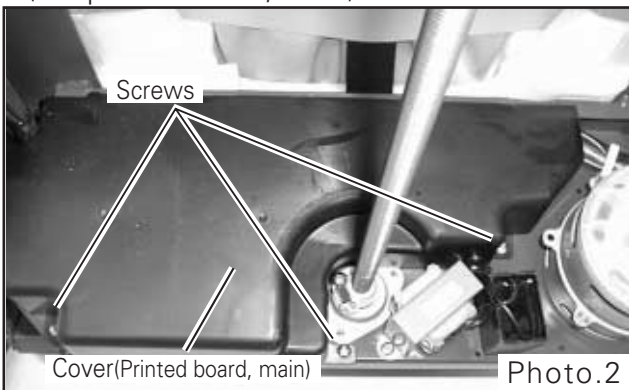

2. Pull out 14 connectors (12 in the case of HEC-902) which are connected to the printed board (main) and thereafter demount the printed board. Photo.3
3. Unscrew two transformer fixing screws to remove the transformer. Photo.3
4. Unscrew two reactor fixing screws and one capacitor fixing screw. Photo.3

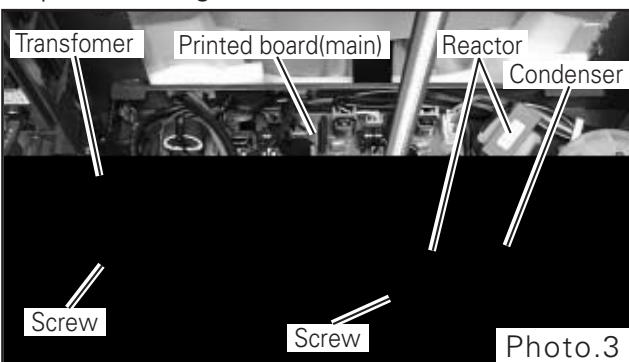

### (3) Replacement of power switch

1. Unscrew two case fixing screws to remove the power switch. Photo.4

\* In removing, shift the switch in arrow direction from the bushing of the remote control cord.

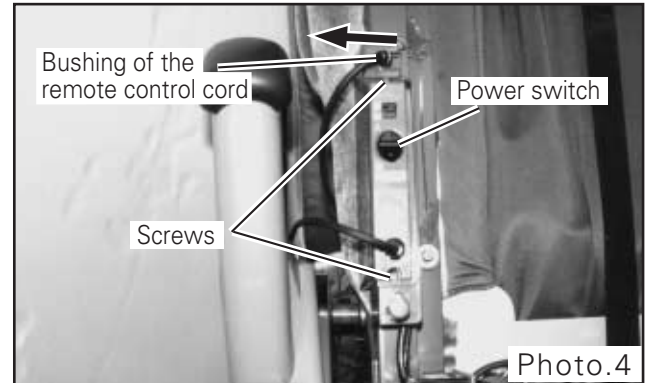

2. Open the power fuse case to take out the fuse. Photo.5
3. Unscrew two switch holder fixing screws to remove the power switch. Photo.5
4. Pull out the auxiliary connector outward, which is fitted in the case (power switch). Photo.5

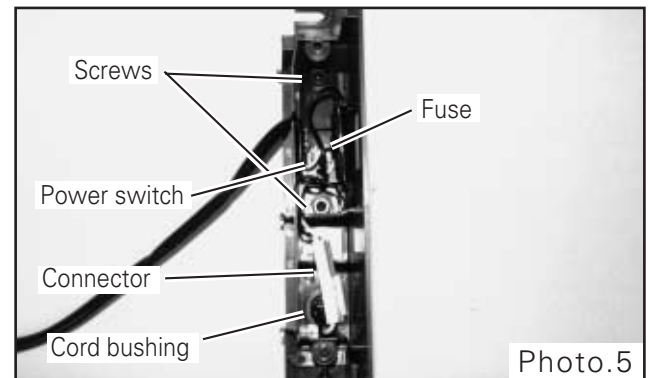

### (4) Replacement of power cord

1. Disconnect the power cord connector to remove the cord bushing from the power cord. Photo.5

### (5) Replacement of remote control

1. Remove the bushing from the remote cord. Photo.4
2. Unscrew four remote control case fixing screws to open the case. Fig.1
3. Unscrew two printed board (remote control) fixing screws to disconnect the remote control cord connector.

## Replacement procedure

HEC-902 (GENERAL)

HEC-904 (GENERAL)

### (6) Replacement of elevation motor

1. Disconnect the elevation motor lead wires.
2. Remove the belt (Rolling) and unscrew four motor mounting screws. Photo.6
3. Remove the pulley (SM) from the elevation motor output shaft and unscrew four elevation motor fixing screws. Photo.6

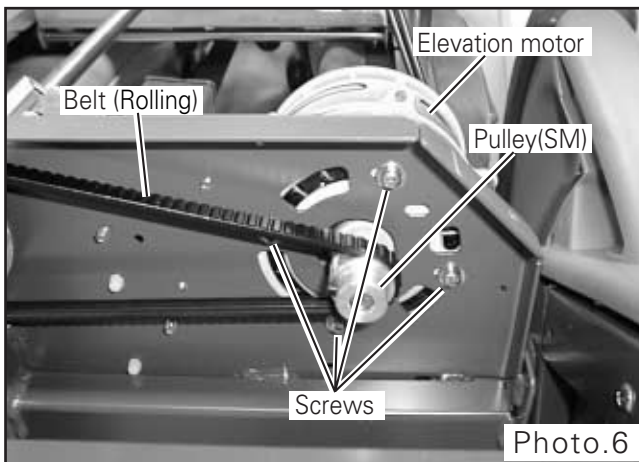

#### • Cautions in reassembling

Apply the elevation belt to the pulley and adjust the belt tension as shown in Photo.7.

Thereafter, tighten four motor mounting screws with specific torque. Photo.7

Adjust and mount the pulley (SM) so its groove is kept in line with that of the pulley (S).

Photo.7

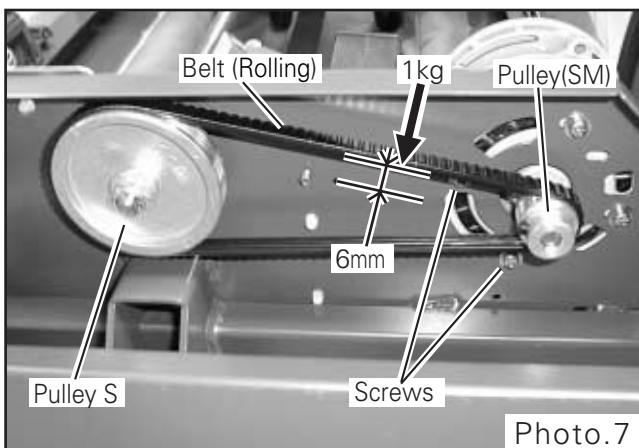

Be careful not to allow adhesion of grease to the belt drive unit, etc.

(Adhesion of grease thereto would result in malfunction due to slip.)

### (7) Replacement of tapping motor

1. Disconnect the tapping motor cord connector.
2. Remove the belt (TATAKI). Photo.8
3. Unscrew one motor fixing screw. Photo.8
4. Unscrew two stay A (motor T) fixing screws and remove the tapping motor unit. Photo.8
5. Draw the pulley (TM) out of the tapping motor shaft and unscrew three tapping motor fixing screws. Photo.8

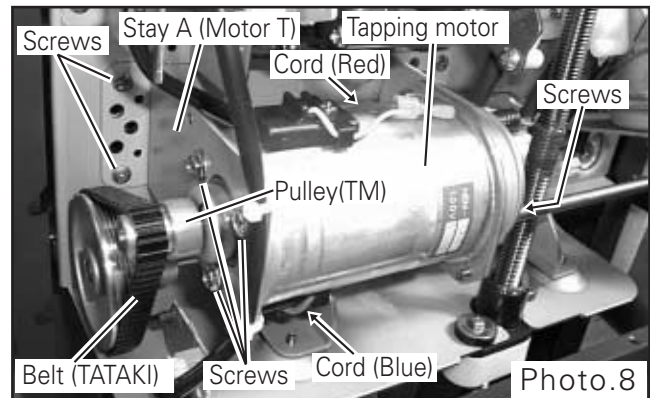

#### Cautions in reassembling

Fix the stay A firmly with two fixing screws so the round portion shown in Photo. 9 is aligned with the holes of the frame and of stay A (motor T). Photo.9.

Adjust and mount the pulley (TM) so its groove is kept in line with the groove of pulley (T).

Photo.9

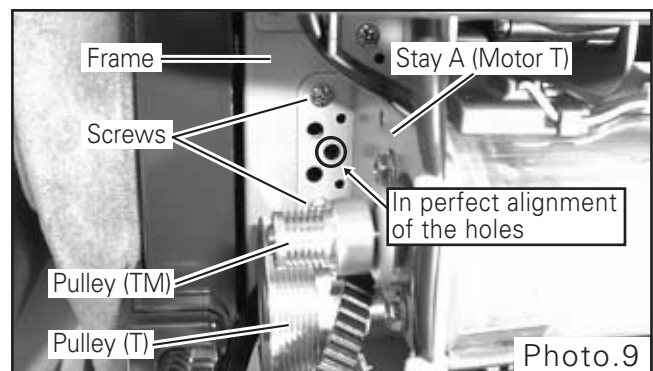

Be careful not to allow adhesion of grease to the belt drive unit, etc.

(Adhesion of grease thereto would result in malfunction due to slip.)

## Replacement procedure

HEC-902 (GENERAL)

HEC-904 (GENERAL)

### (8) Replacement of massage motor

1. Disconnect the massage motor cord connector.
2. Take off the belt (MOMI). Photo.10
3. Unscrew one motor fixing screw. Photo.10
4. Unscrew two stay A (motor M) fixing screws to remove the massage motor unit. Photo.10
5. Draw the pulley (MM) out of the massage motor shaft and unscrew three massage motor fixing screws. Photo.10

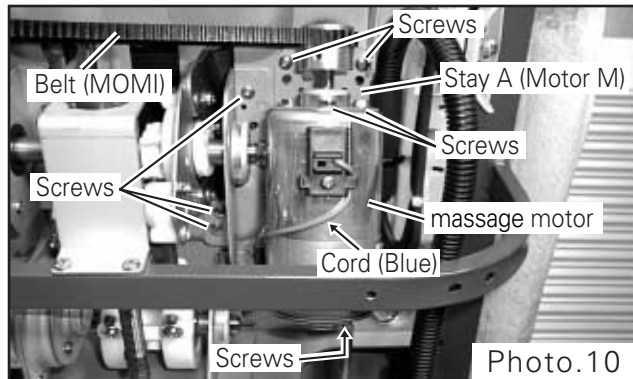

#### • Cautions in reassembling

Fix the stay A firmly with two fixing screws so the round portion shown in Photo. 11 is aligned with the holes of the frame and stay A (motor M). Photo.11

Adjust and mount the pulley (MM) so its groove is kept in line with the groove of the pulley (M). Photo.11

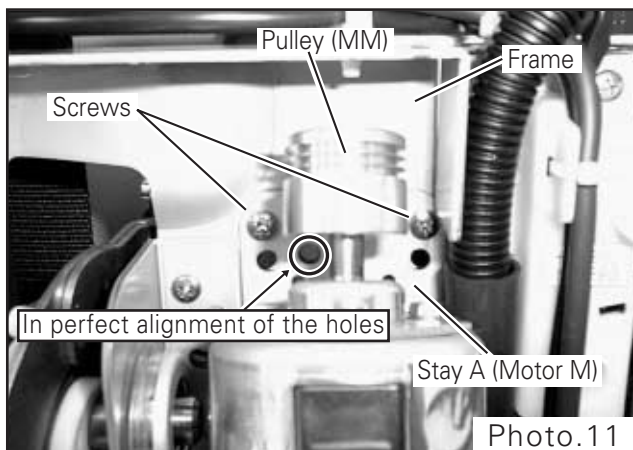

\*Be careful not to allow adhesion of grease to the belt drive unit, etc.  
(Adhesion of grease thereto would result in malfunction due to slip.)

### (9) Replacement of gear box

1. Take off the belt (MOMI). Photo.12
2. Unscrew two stay (HARNESS) fixing screws to remove the stay (HARNESS). Photo.12
3. Unscrew one holder (MAGNET WIDTH) fixing screw to remove the holder (MAGNET WIDTH) from the shaft. Photo.12
4. Take off C-ring from the shaft. Photo.12

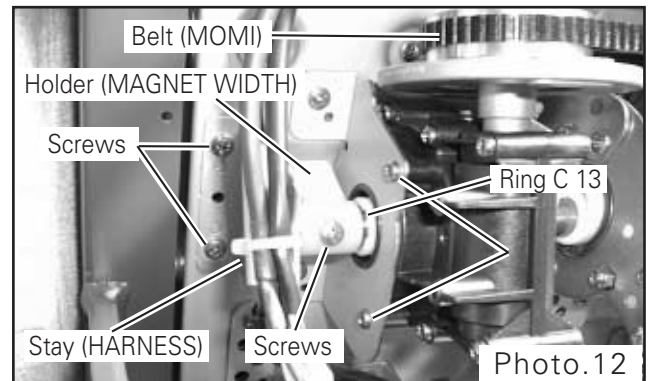

5. Loosen a little four right-side shaft M fixing screws. Photo.10
6. Unscrew four gear box fixing screws to separate the gear box from the shaft. Photo.13
7. Remove the pulley (M) from the gear box. Photo.13
8. Unscrew two stay fixing screws at each side of the gear box to remove the stays (left and right). Photo.13

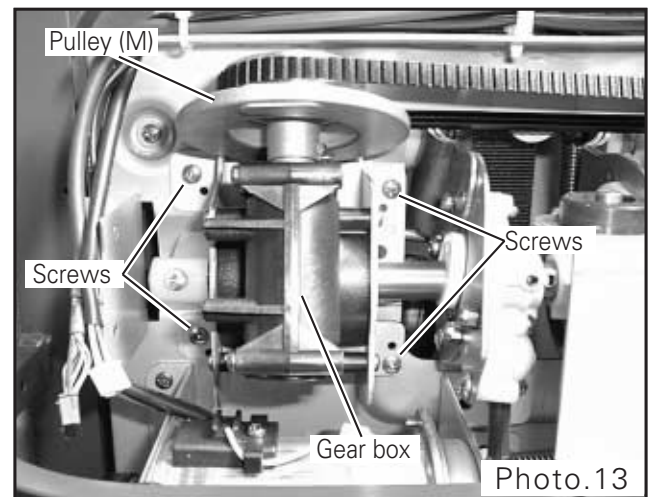

## Replacement procedure

HEC-902 (GENERAL)

HEC-904 (GENERAL)

### (10) Replacement of Printed boards (Relay or pulse)

1. Disconnect three connectors connected to the Printed board (Relay). Photo.14
2. Unscrew one screw fixing the Printed board (Relay) to remove the Printed board (Relay). Photo.14
3. Disconnect one connector connected to the Printed board (pulse). Photo.14
4. Unscrew one screw fixing the Printed board (pulse) to remove the Printed board. Photo.14

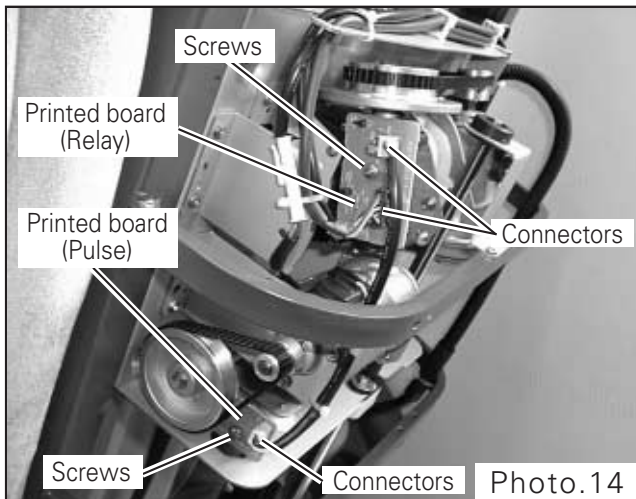

### (11) Replacement of limit switch

1. Unscrew three switch holder fixing screws. Photo.15
2. Unscrew two switch fixing screws (upper and lower: one each). After that, remove solder from each switch terminal to demount the switch. Photo.15

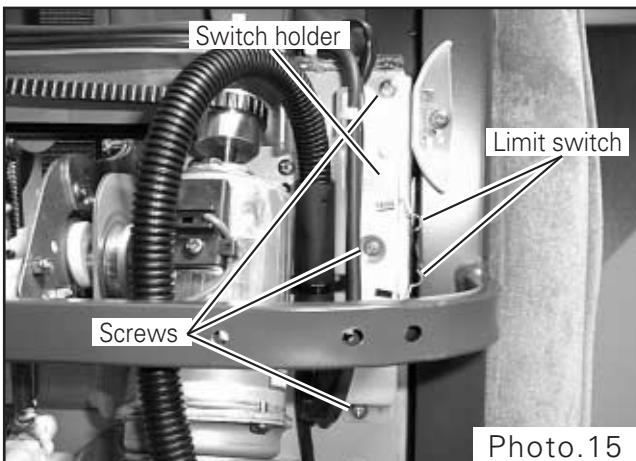

### (12) How to remove the back rest

1. Turn OFF the power switch after moving the massage unit to the position shown in Photo. 16 using "UP/DOWN ADJUSTMENT" on the remote control.
2. Unscrew five back rest (pair) fixing screws to remove the back rest (pair). Photo.16

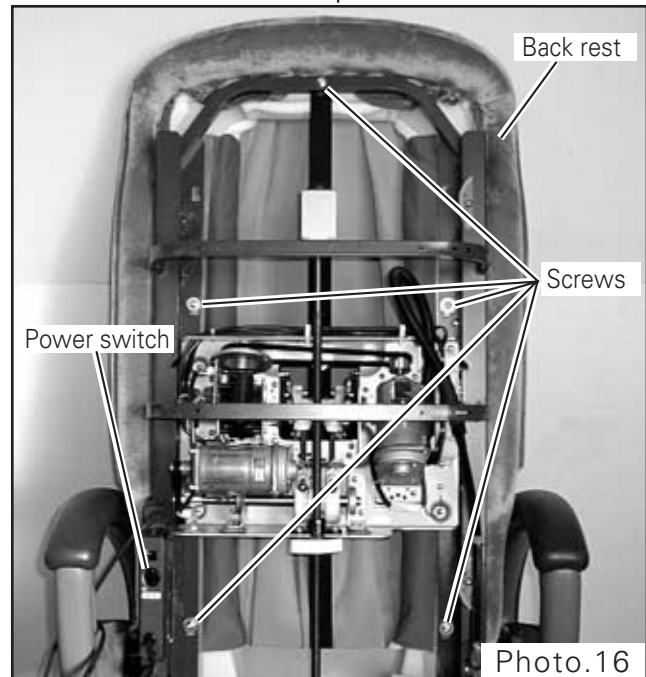

### (13) Replacement of right and left arm

1. Remove the helical spring for the arm. Photo.14
  2. Unscrew the right arm fixing nut to remove the right arm. (Also, remove the left arm similarly.) Photo.14
- \* Remove the left arm similarly.

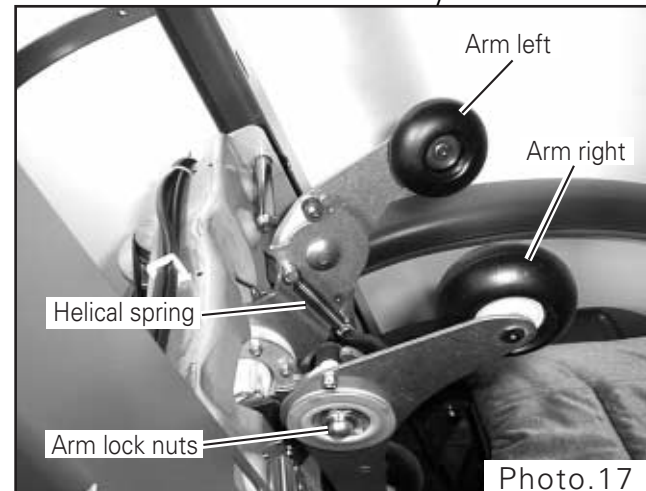

## Replacement procedure

HEC-902 (GENERAL)

HEC-904 (GENERAL)

### (14) Replacement of screw bar

1. Unscrew two nut (plastic nut) lock screws. Photo.18
2. Unscrew two holder (Screw rod, upper) fixing screws and remove the holder, subsequently taking out the massage unit upward. Photo.18
3. After temporarily locking the magnet with a pliers or the like, unscrew the backside pulley (S) fixing nut and remove the pulley (S) from the screw rod. Photo.18
3. Unscrew two screw rod holder screws from the backside. Photo.18

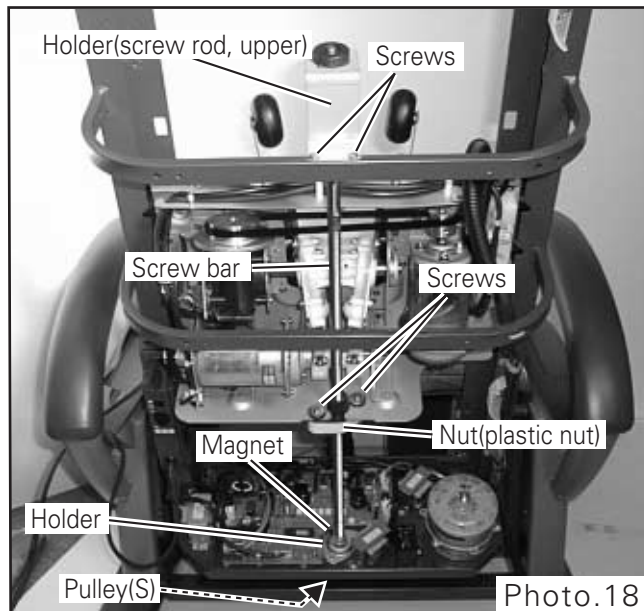

### (15) Replacement of leg vibrator

1. Disconnect the lead wires of the leg vibrator motor.
2. Remove the seat cover from underside, with the foot rest lifted.
3. Open the fastener and take out the leg vibrator. Fig.16

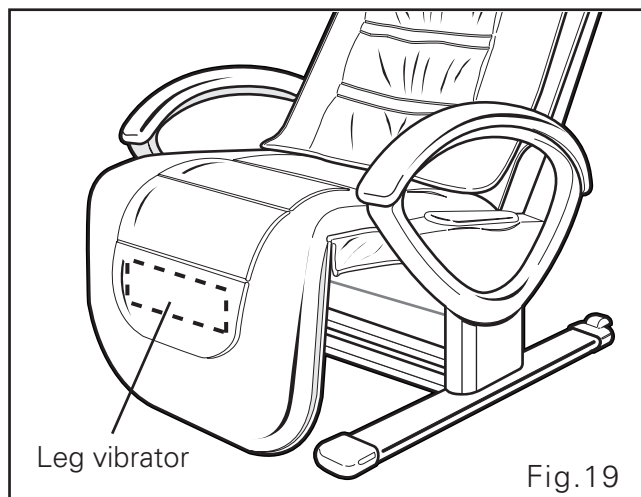

### (16) Replacement of transformer

1. Unscrew three fixing screws to remove the transformer cover. Photo.20

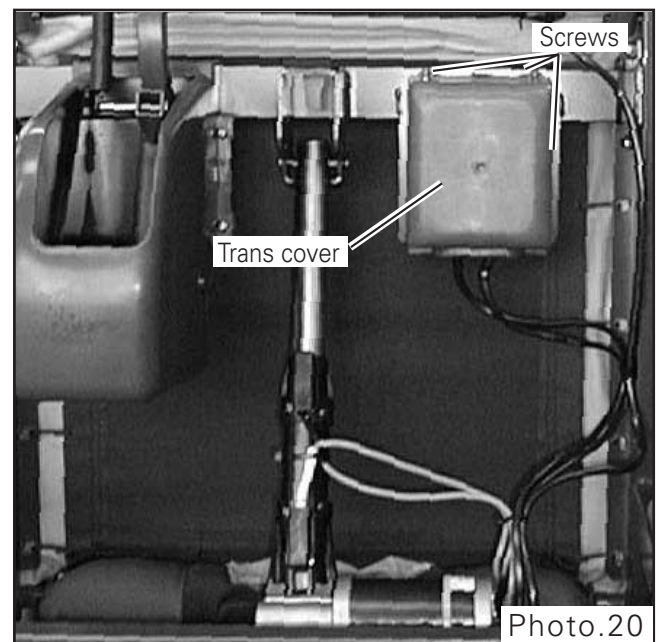

2. Unscrew fixing screws to remove the folder and pull out a connector.
3. Unscrew fixing screws to remove the transformer. Photo.21

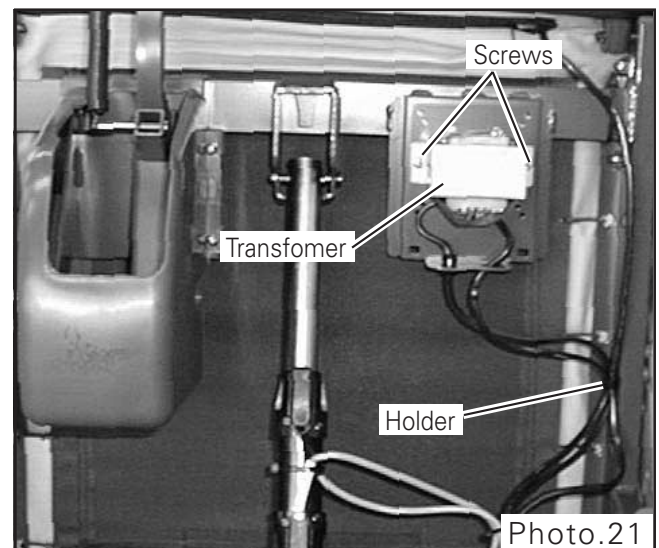

## Replacement procedure

HEC-902 (GENERAL)

HEC-904 (GENERAL)

### (17) Replacement of reclining unit

#### • HEC-902

1. Disconnect the reclining wire.
2. The cylinder is fixed at its both end sides. Take off the lock C-ring at the both sides and pull out the pin. Photo.21

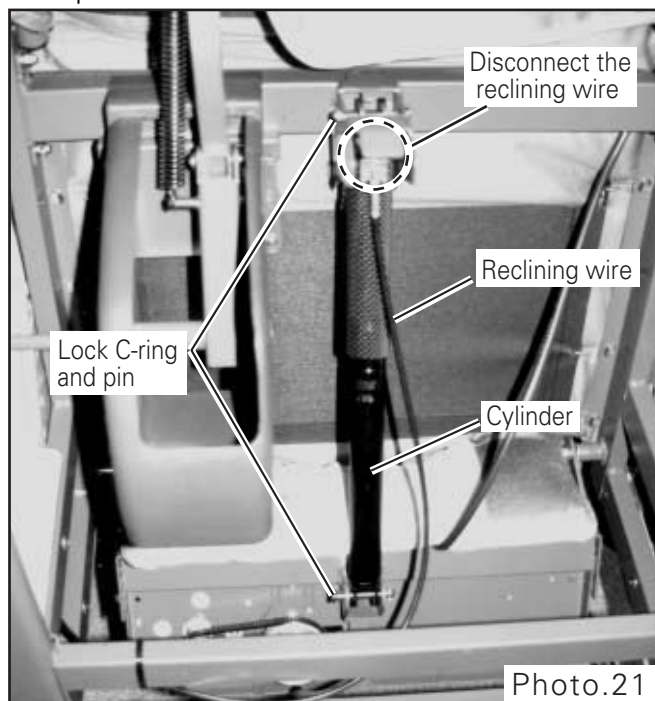

#### • HEC-904

1. Disconnect the lead wires from the reclining motor.
2. The reclining motor is fixed at the both end sides. Take off the lock C-rings from the both ends and pull out the pin. Photo.22

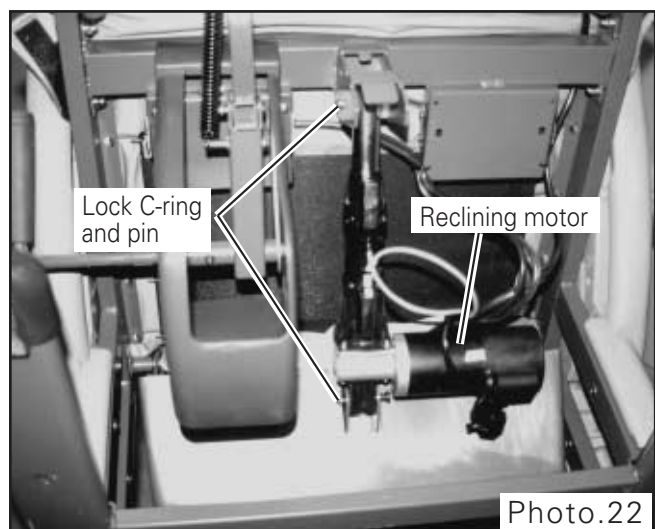

**SANYO**