

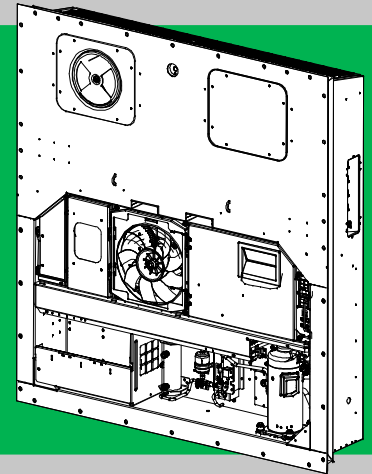

Container Refrigeration

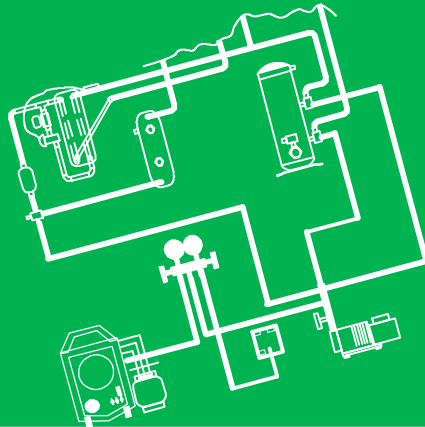

OPERATION AND SERVICE
for
69NT40-561-001 to 199
Container Refrigeration Units

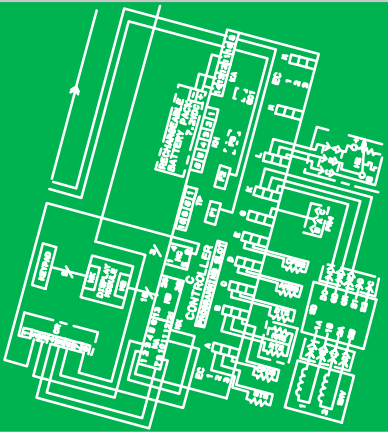

TRANSICOLD

**OPERATION AND SERVICE MANUAL
CONTAINER REFRIGERATION UNIT**

**Models
69NT40-561-001 to 199**

TABLE OF CONTENTS

PARAGRAPH NUMBER	Page
GENERAL SAFETY NOTICES	Safety-1
FIRST AID	Safety-1
OPERATING PRECAUTIONS	Safety-1
MAINTENANCE PRECAUTIONS	Safety-1
SPECIFIC WARNING AND CAUTION STATEMENTS	Safety-1
INTRODUCTION	1-1
1.1 INTRODUCTION	1-1
1.2 CONFIGURATION IDENTIFICATION	1-1
1.3 OPTION DESCRIPTION	1-1
1.3.1 Battery	1-1
1.3.2 Dehumidification	1-1
1.3.3 Control Box	1-1
1.3.4 Temperature Readout	1-1
1.3.5 Pressure Readout	1-1
1.3.6 USDA	1-1
1.3.7 Interrogator	1-1
1.3.8 Remote Monitoring	1-1
1.3.9 Communications	1-1
1.3.10 Compressor	1-1
1.3.11 Condenser Coil	1-1
1.3.12 Autotransformer	1-2
1.3.13 Temperature Recorder	1-2
1.3.14 Handles	1-2
1.3.15 Thermometer Port	1-2
1.3.16 Water Cooling	1-2
1.3.17 Back Panels	1-2
1.3.18 460 Volt Cable	1-2
1.3.19 230 Volt Cable	1-2
1.3.20 Cable Restraint	1-2
1.3.21 Upper Air (Fresh Air Make Up)	1-2
1.3.22 Lower Air (Fresh Air Make Up)	1-2
1.3.23 Evaporator	1-2
1.3.24 Evaporator Fan Operation	1-2
1.3.25 Labels	1-2
1.3.26 Plate Set	1-2
1.3.27 Controller	1-2
1.3.28 Condenser Grille	1-2
DESCRIPTION	2-1
2.1 GENERAL DESCRIPTION	2-1
2.1.1 Refrigeration Unit - Front Section	2-1
2.1.2 Fresh Air Makeup Vent	2-1
2.1.3 Evaporator Section	2-2
2.1.4 Compressor Section	2-3
2.1.5 Air-Cooled Condenser Section	2-4

TABLE OF CONTENTS - Continued

PARAGRAPH NUMBER	Page
2.1.6 Water-Cooled Condenser Section	2-5
2.1.7 Control Box Section	2-6
2.1.8 Communications Interface Module	2-6
2.2 REFRIGERATION SYSTEM DATA	2-7
2.3 ELECTRICAL DATA	2-8
2.4 SAFETY AND PROTECTIVE DEVICES	2-9
2.5 REFRIGERATION CIRCUIT	2-10
2.5.1 Standard Operation	2-10
2.5.2 Economized Operation	2-10
2.5.3 Liquid Injection Valve	2-10
2.5.4 Electronic Expansion Valve	2-10
MICROPROCESSOR	3-1
3.1 TEMPERATURE CONTROL MICROPROCESSOR SYSTEM	3-1
3.1.1 Keypad	3-2
3.1.2 Display Module	3-2
3.1.3 Controller	3-3
3.2 CONTROLLER SOFTWARE	3-3
3.2.1 Configuration Software (Variables)	3-3
3.2.2 Operational Software (Function Codes)	3-3
3.3 CONTROLLER SEQUENCE AND MODES OF OPERATION	3-4
3.3.1 Start up - Compressor Phase Sequence	3-4
3.3.2 Start up - Compressor Bump Start	3-4
3.3.3 Perishable Set Point Temperature - Perishable Pulldown	3-4
3.3.4 Perishable Set Point Temperature - Conventional Temperature Control Mode	3-4
3.3.5 Perishable Set Point Temperature - Economy Mode	3-4
3.3.6 Perishable Set Point Temperature Control	3-4
3.3.7 Perishable Mode Cooling - Sequence of Operation	3-5
3.3.8 Perishable Mode Heating - Sequence of Operation	3-6
3.3.9 Sequence of Operation - Perishable Mode (Capacity Trim Heat)	3-6
3.3.10 Perishable Mode - Dehumidification	3-6
3.3.11 Perishable, Dehumidification - Bulb Mode	3-7
3.3.12 Frozen - Pulldown	3-7
3.3.13 Frozen Mode Temperature Control	3-7
3.3.14 Frozen Mode - Conventional	3-7
3.3.15 Frozen Mode - Heat Lockout Temperature	3-7
3.3.16 Frozen Mode - Economy	3-7
3.3.17 Frozen Mode Cooling - Sequence of Operation	3-8
3.3.18 Defrost Interval	3-9
3.3.19 Defrost Mode - Sequence of Operation	3-9
3.4 PROTECTION MODES OF OPERATION	3-10
3.4.1 Evaporator Fan Operation	3-10
3.4.2 Failure Action	3-10
3.4.3 Generator Protection	3-10
3.4.4 Compressor High Temperature, Low Pressure Protection	3-10

TABLE OF CONTENTS - Continued

PARAGRAPH NUMBER	Page
3.4.5 Perishable Mode - System Pressure Regulation	3-10
3.4.6 Condenser Fan Switch Override	3-10
3.5 CONTROLLER ALARMS	3-10
3.6 UNIT PRE-TRIP DIAGNOSTICS	3-11
3.7 DataCORDER	3-11
3.7.1 Description	3-11
3.7.2 DataCORDER Software	3-11
3.7.3 Sensor Configuration (dCF02)	3-12
3.7.4 Logging Interval (dCF03)	3-12
3.7.5 Thermistor Format (dCF04)	3-12
3.7.6 Sampling Type (dCF05 & dCF06)	3-14
3.7.7 Alarm Configuration (dCF07 - dCF10)	3-14
3.7.8 DataCORDER Power-Up	3-14
3.7.9 Pre-Trip Data Recording	3-14
3.7.10 DataCORDER Communications	3-14
3.7.11 USDA Cold Treatment	3-15
3.7.12 USDA Cold Treatment Procedure	3-15
3.7.13 DataCORDER Alarms	3-16
3.7.14 ISO Trip Header	3-16
OPERATION	4-1
4.1 INSPECTION (Before Starting)	4-1
4.2 CONNECT POWER	4-1
4.2.1 Connection To 380/460 VAC Power	4-1
4.2.2 Connection To 190/230 VAC Power	4-1
4.3 ADJUST FRESH AIR MAKEUP VENT	4-1
4.3.1 Upper Fresh Air Makeup Vent	4-2
4.3.2 Lower Fresh Air Makeup Vent	4-2
4.3.3 Vent Position Sensor	4-2
4.4 CONNECT WATER-COOLED CONDENSER	4-2
4.4.1 Water-Cooled Condenser with Water Pressure Switch	4-2
4.4.2 Water-Cooled Condenser with Condenser Fan Switch	4-2
4.5 CONNECT REMOTE MONITORING RECEPTACLE	4-3
4.6 STARTING AND STOPPING INSTRUCTIONS	4-3
4.6.1 Starting the Unit	4-3
4.6.2 Stopping the Unit	4-3
4.7 START-UP INSPECTION	4-3
4.7.1 Physical Inspection	4-3
4.7.2 Check Controller Function Codes	4-3
4.7.3 Start Temperature Recorder	4-3
4.7.4 Complete Inspection	4-3
4.8 PRE-TRIP DIAGNOSIS	4-3
4.9 OBSERVE UNIT OPERATION	4-4
4.9.1 Probe Check	4-4
TROUBLESHOOTING	5-1
5.1 UNIT WILL NOT START OR STARTS THEN STOPS	5-1

TABLE OF CONTENTS - Continued

PARAGRAPH NUMBER	Page
5.2 UNIT OPERATES LONG OR CONTINUOUSLY IN COOLING	5-1
5.3 UNIT RUNS BUT HAS INSUFFICIENT COOLING	5-2
5.4 UNIT WILL NOT HEAT OR HAS INSUFFICIENT HEATING	5-2
5.5 UNIT WILL NOT TERMINATE HEATING	5-2
5.6 UNIT WILL NOT DEFROST PROPERLY	5-2
5.7 UNIT WILL NOT DEFROST PROPERLY (Continued)	5-3
5.8 ABNORMAL PRESSURES (COOLING)	5-3
5.9 ABNORMAL NOISE OR VIBRATIONS	5-3
5.10 MICROPROCESSOR MALFUNCTION	5-3
5.11 NO EVAPORATOR AIR FLOW OR RESTRICTED AIR FLOW	5-4
5.12 ELECTRONIC EXPANSION VALVE MALFUNCTION	5-4
5.13 AUTOTRANSFORMER MALFUNCTION	5-4
5.14 WATER-COOLED CONDENSER OR WATER PRESSURE SWITCH	5-4
5.15 COMPRESSOR OPERATING IN REVERSE	5-5
5.16 ABNORMAL TEMPERATURES	5-5
5.17 ABNORMAL CURRENTS	5-5
SERVICE	6-1
6.1 SECTION LAYOUT	6-1
6.2 MANIFOLD GAUGE SET	6-1
6.3 REFRIGERATION SYSTEM SERVICE-UNITS WITH STANDARD PIPING (with Service Valves)	6-2
6.3.1 Service Connections	6-2
6.3.2 Pumping Down the Unit	6-2
6.3.3 Refrigerant Leak Checking	6-3
6.3.4 Evacuation and Dehydration	6-3
6.3.5 Refrigerant Charge	6-4
6.4 COMPRESSOR	6-4
6.4.1 Removal and Replacement of Compressor	6-5
6.5 HIGH PRESSURE SWITCH	6-6
6.5.1 Replacing High Pressure Switch	6-6
6.5.2 Checking High Pressure Switch	6-6
6.6 CONDENSER COIL	6-6
6.7 CONDENSER FAN AND MOTOR ASSEMBLY	6-7
6.8 WATER-COOLED CONDENSER CLEANING	6-7
6.9 FILTER DRIER	6-9
6.10 EVAPORATOR COIL AND HEATER ASSEMBLY	6-9
6.10.1 Evaporator Coil Replacement	6-9
6.10.2 Evaporator Heater Replacement	6-9
6.11 EVAPORATOR FAN AND MOTOR ASSEMBLY	6-9
6.11.1 Replacing The Evaporator Fan Assembly	6-10
6.11.2 Disassemble The Evaporator Fan Assembly	6-10
6.11.3 Assemble The Evaporator Fan Assembly	6-10
6.12 ELECTRONIC EXPANSION VALVE	6-10
6.12.1 Replacing Expansion Valve and Screen	6-11
6.13 ECONOMIZER EXPANSION VALVE	6-11
6.13.1 Valve Replacement	6-11

TABLE OF CONTENTS - Continued

PARAGRAPH NUMBER	Page
6.14 ECONOMIZER AND LIQUID INJECTION SOLENOID VALVES	6-12
6.15 DIGITAL UNLOADER VALVE	6-12
6.16 VALVE OVERRIDE CONTROLS	6-13
6.17 AUTOTRANSFORMER	6-15
6.18 CONTROLLER	6-15
6.18.1 Handling Modules	6-15
6.18.2 Controller Troubleshooting	6-15
6.18.3 Controller Programming Procedure	6-16
6.18.4 Removing and Installing a Module	6-18
6.18.5 Battery Replacement	6-18
6.19 VENT POSITION SENSOR SERVICE	6-18
6.20 TEMPERATURE SENSOR SERVICE	6-19
6.20.1 Sensor Checkout Procedure	6-19
6.20.2 Sensor Replacement	6-19
6.20.3 Sensor Re-Installation	6-20
6.21 ELECTRONIC PARTLOW TEMPERATURE RECORDER	6-22
6.22 MAINTENANCE OF PAINTED SURFACES	6-24
6.23 COMMUNICATIONS INTERFACE MODULE INSTALLATION	6-24
ELECTRICAL WIRING SCHEMATICS	7-1
7.1 INTRODUCTION	7-1

LIST OF ILLUSTRATIONS

FIGURE NUMBER	Page
Figure 2-1 Refrigeration Unit - Front Section	2-1
Figure 2-2 Evaporator Section	2-2
Figure 2-3 Compressor Section	2-3
Figure 2-4 Air-Cooled Condenser Section	2-4
Figure 2-5 Water-Cooled Condenser Section	2-5
Figure 2-6 Control Box Section	2-6
Figure 2-7 Refrigeration Circuit Schematic - Standard Operation	2-11
Figure 2-8 Refrigeration Circuit Schematic - Economized Operation	2-12
Figure 3-1 Temperature Control System	3-1
Figure 3-2 Keypad	3-2
Figure 3-3 Display Module	3-3
Figure 3-4 Control Module	3-3
Figure 3-5 Controller Operation - Perishable Mode	3-5
Figure 3-6 Perishable Mode - Cooling	3-5
Figure 3-7 Perishable Mode Heating	3-6
Figure 3-8 Controller Operation - Frozen Mode	3-8
Figure 3-9 Frozen Mode	3-8
Figure 3-10 Defrost	3-10
Figure 3-11 Standard Configuration Download Report	3-13
Figure 3-12 Data Reader	3-15
Figure 4-1 Autotransformer	4-1
Figure 6-1 Manifold Gauge Set	6-1
Figure 6-2 R-134a Manifold Gauge/Hose Set	6-1
Figure 6-3 Service Valve	6-2
Figure 6-4 Refrigeration System Service Connections	6-3
Figure 6-5 Compressor Kit	6-5
Figure 6-6 High Pressure Switch Testing	6-6
Figure 6-7 Water-Cooled Condenser Cleaning - Forced Circulation	6-8
Figure 6-8 Water-Cooled Condenser Cleaning - Gravity Circulation	6-9
Figure 6-9 Evaporator Fan Assembly	6-10
Figure 6-10 Electronic Expansion Valve	6-11
Figure 6-11 Economizer Expansion Valve	6-11
Figure 6-12 Hermetic Thermostatic Expansion Valve Brazing Procedure	6-12
Figure 6-13 Coil View of Economizer Solenoid Valve (ESV) and Liquid Injection Valve (LIV)	6-12
Figure 6-14 Controller Section of the Control Box	6-16
Figure 6-15 Sensor Types	6-20
Figure 6-16 Sensor and Cable Splice	6-20
Figure 6-17 Supply Sensor Positioning	6-21
Figure 6-18 Return Sensor Positioning	6-21
Figure 6-19 Evaporator Temperature Sensor Positioning	6-21
Figure 6-20 Electronic Partlow Temperature Recorder	6-23
Figure 6-21 Communications Interface Installation	6-24
Figure 7-1 LEGEND	7-1
Figure 7-2 SCHEMATIC DIAGRAM	7-2
Figure 7-3 SCHEMATIC AND WIRING DIAGRAM - Vent Position Sensors (VPS)	7-3
Figure 7-4 UNIT SCHEMATIC DIAGRAM	7-4

LIST OF TABLES

TABLE NUMBER	Page
Table 2-1 Safety and Protective Devices	2-9
Table 3-1 Keypad Function	3-2
Table 3-2 DataCORDER Configuration Variables	3-12
Table 3-3 DataCORDER Standard Configurations	3-14
Table 3-4 Controller Configuration Variables	3-17
Table 3-5 Controller Function Codes	3-19
Table 3-6 Controller Alarm Indications	3-23
Table 3-7 Controller Pre-Trip Test Codes	3-27
Table 3-8 DataCORDER Function Code Assignments	3-31
Table 3-9 DataCORDER Pre-Trip Result Records	3-32
Table 3-10 DataCORDER Alarm Indications	3-33
Table 6-1 Valve Override Control Displays	6-14
Table 6-2 Sensor Temperature/Resistance Chart	6-19
Table 6-3 Recommended Bolt Torque Values	6-24
Table 6-4 R-134a Temperature - Pressure Chart	6-25

SAFETY SUMMARY

GENERAL SAFETY NOTICES

The following general safety notices supplement specific warnings and cautions appearing elsewhere in this manual. They are recommended precautions that must be understood and applied during operation and maintenance of the equipment covered herein. The general safety notices are presented in the following three sections labeled: First Aid, Operating Precautions and Maintenance Precautions. A listing of the specific warnings and cautions appearing elsewhere in the manual follows the general safety notices.

FIRST AID

An injury, no matter how slight, should never go unattended. Always obtain first aid or medical attention immediately.

OPERATING PRECAUTIONS

Always wear safety glasses.

Keep hands, clothing and tools clear of the evaporator and condenser fans.

No work should be performed on the unit until all circuit breakers and start-stop switches are turned off, and power supply is disconnected.

Always work in pairs. Never work on the equipment alone.

In case of severe vibration or unusual noise, stop the unit and investigate.

MAINTENANCE PRECAUTIONS

Beware of unannounced starting of the evaporator and condenser fans. Do not open the condenser fan grille or evaporator access panels before turning power off, disconnecting and securing the power plug.

Be sure power is turned off before working on motors, controllers, solenoid valves and electrical control switches. Tag circuit breaker and power supply to prevent accidental energizing of circuit.

Do not bypass any electrical safety devices, e.g. bridging an overload, or using any sort of jumper wires. Problems with the system should be diagnosed, and any necessary repairs performed by qualified service personnel.

When performing any arc welding on the unit or container, disconnect all wire harness connectors from the modules in both control boxes. Do not remove wire harness from the modules unless you are grounded to the unit frame with a static safe wrist strap.

In case of electrical fire, open circuit switch and extinguish with CO₂ (never use water).

SPECIFIC WARNING AND CAUTION STATEMENTS

To help identify the label hazards on the unit and explain the level of awareness each one carries, an explanation is given with the appropriate consequences:

DANGER - means an immediate hazard that **WILL** result in severe personal injury or death.

WARNING - means to warn against hazards or unsafe conditions that **COULD** result in severe personal injury or death.

CAUTION - means to warn against potential hazard or unsafe practice that could result in minor personal injury, product or property damage.

The statements listed below are applicable to the refrigeration unit and appear elsewhere in this manual. These recommended precautions must be understood and applied during operation and maintenance of the equipment covered herein.

DANGER

Never use air for leak testing. It has been determined that pressurized, mixtures of refrigerant and air can undergo combustion when exposed to an ignition source.

WARNING

Beware of unannounced starting of the evaporator and condenser fans. The unit may cycle the fans and compressor unexpectedly as control requirements dictate.

WARNING

Do not attempt to remove power plug(s) before turning OFF start-stop switch (ST), unit circuit breaker(s) and external power source.

WARNING

Make sure the power plugs are clean and dry before connecting to power receptacle.

WARNING

Make sure that the unit circuit breaker(s) (CB-1 & CB-2) and the START-STOP switch (ST) are in the "O" (OFF) position before connecting to any electrical power source.

WARNING

Never use air for leak testing. It has been determined that pressurized, air-rich mixtures of refrigerants and air can undergo combustion when exposed to an ignition source.

 **WARNING**

Make sure power to the unit is OFF and power plug disconnected before replacing the compressor.

 **WARNING**

Before disassembly of the compressor, be sure to relieve the internal pressure very carefully by slightly loosening the couplings to break the seal.

 **WARNING**

Do not use a nitrogen cylinder without a pressure regulator. Do not use oxygen in or near a refrigeration system as an explosion may occur.

 **WARNING**

Do not open the condenser fan grille before turning power OFF and disconnecting power plug.

 **WARNING**

Do not open condenser fan grille before turning power OFF and disconnecting power plug.

 **WARNING**

Oakite No. 32 is an acid. Be sure that the acid is slowly added to the water. **DO NOT PUT WATER INTO THE ACID** - this will cause spattering and excessive heat.

 **WARNING**

Wear rubber gloves and wash the solution from the skin immediately if accidental contact occurs. Do not allow the solution to splash onto concrete.

 **WARNING**

Always turn OFF the unit circuit breakers (CB-1 & CB-2) and disconnect main power supply before working on moving parts.

 **WARNING**

Installation requires wiring to the main unit circuit breaker, CB1. Make sure the power to the unit is off and power plug disconnected before beginning installation.

 **CAUTION**

Do not remove wire harnesses from controller modules unless you are grounded to the unit frame with a static safe wrist strap.

 **CAUTION**

Unplug all controller module wire harness connectors before performing arc welding on any part of the container.

 **CAUTION**

Do not attempt to use an ML2i PC card in an ML3 equipped unit. The PC cards are physically different and will result in damage to the controller.

 **CAUTION**

Pre-trip inspection should not be performed with critical temperature cargoes in the container.

 **CAUTION**

When Pre-Trip key is pressed, economy, dehumidification and bulb mode will be deactivated. At the completion of Pre-Trip activity, economy, dehumidification and bulb mode must be reactivated.

 **CAUTION**

When condenser water flow is below 11 lpm (3 gpm) or when water-cooled operation is not in use, the CFS switch **MUST** be set to position "1" or the unit will not operate properly.

 **CAUTION**

Pre-trip inspection should not be performed with critical temperature cargoes in the container.

 **CAUTION**

When Pre-Trip key is pressed, economy, dehumidification and bulb mode will be deactivated. At the completion of Pre-Trip activity, economy, dehumidification and bulb mode must be reactivated.

 **CAUTION**

When a failure occurs during automatic testing, the unit will suspend operation awaiting operator intervention.

 **CAUTION**

When Pre-Trip test Auto 2 runs to completion without being interrupted, the unit will terminate pre-trip and display "Auto 2" "end." The unit will suspend operation until the user depresses the ENTER key!

 **CAUTION**

Allowing the scroll compressor to operate in reverse for more than two minutes will result in internal compressor damage. Turn the start-stop switch OFF immediately.

 **CAUTION**

To prevent trapping liquid refrigerant in the manifold gauge set be sure set is brought to suction pressure before disconnecting.

 **CAUTION**

The scroll compressor achieves low suction pressure very quickly. Do not operate the compressor in a deep vacuum, internal damage will result.

 **CAUTION**

The scroll compressor achieves low suction pressure very quickly. Do not use the compressor to evacuate the system below 0 psig. Never operate the compressor with the suction or discharge service valves closed (frontseated). Internal damage will result from operating the compressor in a deep vacuum.

 **CAUTION**

Take necessary steps (place plywood over coil or use sling on motor) to prevent motor from falling into condenser coil.

 **CAUTION**

Do not remove wire harnesses from module unless you are grounded to the unit frame with a static safe wrist strap.

 **CAUTION**

Unplug all module connectors before performing arc welding on any part of the container.

 **CAUTION**

The unit must be OFF whenever a programming card is inserted or removed from the controller programming port.

 **CAUTION**

Use care when cutting wire ties to avoid nicking or cutting wires.

 **CAUTION**

Do not allow moisture to enter wire splice area as this may affect the sensor resistance.

 **CAUTION**

Do not allow the recorder stylus to snap back down. The stylus arm base is spring loaded, and damage may occur to the chart, or the stylus force may be altered.

DO NOT move the stylus arm up and down on the chart face. This will result in damage to the stylus motor gear.

SECTION 1

INTRODUCTION

1.1 INTRODUCTION

The Carrier Transicold model 69NT40-561-001 to 199 series units are of lightweight aluminum frame construction, designed to fit in the front of a container and serve as the container's front wall.

They are one piece, self-contained, all electric units, which include cooling and heating systems to provide precise temperature control.

The units are supplied with a complete charge of refrigerant R-134a and compressor lubricating oil, and are ready for operation upon installation. Forklift pockets are provided for unit installation and removal.

The base unit operates on nominal 380/460 volt, 3-phase, 50/60 hertz (Hz) power. An optional autotransformer may be fitted to allow operation on nominal 190/230, 3-phase, 50/60 Hz power. Power for the control system is provided by a transformer which steps the supply power down to 18 and 24 volts, single phase.

The controller is a Carrier Transicold Micro-Link 3 microprocessor. The controller will operate automatically to select cooling, holding or heating as required to maintain the desired set point temperature within very close limits. The unit may also be equipped with an electronic temperature recorder.

The controller has a keypad and display for viewing or changing operating parameters. The display is also equipped with lights to indicate various modes of operation.

1.2 CONFIGURATION IDENTIFICATION

Unit identification information is provided on a plate located near the economizer heat exchanger, on the back wall of the condenser section. The plate provides the unit model number, the unit serial number and the unit parts identification number (PID). The model number identifies the overall unit configuration, while the PID provides information on specific optional equipment, factory provisioned to allow for field installation of optional equipment and differences in detailed parts.

Configuration identification for the models covered herein may be obtained in the Container Identification Matrix located in the Container Products Group Information Center available to authorized Carrier Transicold Service Centers.

1.3 OPTION DESCRIPTION

Various options may be factory or field equipped to the base unit. These options are listed in the tables and described in the following subparagraphs.

1.3.1 Battery

The refrigeration controller may be fitted with standard replaceable batteries or a rechargeable battery pack. Rechargeable battery packs may be fitted in the standard or in a secure location.

1.3.2 Dehumidification

The unit may be fitted with a humidity sensor. This sensor allows setting of a humidity set point in the controller. In dehumidification mode, the controller will operate to reduce internal container moisture level.

1.3.3 Control Box

Units are equipped with either an aluminum or composite material box, and may be fitted with a lockable door.

1.3.4 Temperature Readout

The unit is fitted with suction and discharge temperature sensors. The sensor readings may be viewed on the controller display.

1.3.5 Pressure Readout

The unit is fitted with evaporator and discharge transducers. The transducer readings may be viewed on the controller display.

1.3.6 USDA

The unit may be supplied with fittings for additional temperature probes, which allow recording of USDA Cold Treatment data by the integral DataCORDER function of the Micro-Link refrigeration controller.

1.3.7 Interrogator

Units that use the DataCORDER function are fitted with interrogator receptacles for connection of equipment to download the recorded data. Two receptacles may be fitted; one is accessible from the front of the container and the other is mounted inside the container (with the USDA receptacles).

1.3.8 Remote Monitoring

The unit may be fitted with a remote monitoring receptacle. This item allows connection of remote indicators for COOL, DEFROST and IN RANGE. Unless otherwise indicated, the receptacle is mounted at the control box location.

1.3.9 Communications

The unit may be fitted with a communications interface module. The communications interface module is a slave module, which allows communication with a master central monitoring station. The module will respond to communication and return information over the main power line. Refer to the ship master system technical manual for further information.

1.3.10 Compressor

The unit is fitted with a scroll compressor that is equipped with suction and discharge service connections.

1.3.11 Condenser Coil

The unit is fitted with a four-row coil using 7mm tubing.

1.3.12 Autotransformer

An autotransformer may be provided to allow operation on 190/230, 3-phase, 50/60 Hz power. The autotransformer raises the supply voltage to the nominal 380/460 volt power required by the base unit. The autotransformer may also be fitted with an individual circuit breaker for the 230 volt power.

If the unit is equipped with an autotransformer and communications module, the autotransformer will be fitted with a transformer bridge unit (TBU) to assist in communications.

1.3.13 Temperature Recorder

The units may be fitted with an electronic temperature recording device manufactured by the Partlow Corporation.

1.3.14 Handles

The unit may be equipped with handles to facilitate access to stacked containers. These fixed handles are located on either side of the unit.

1.3.15 Thermometer Port

The unit may be fitted with ports in the front of the frame for insertion of a thermometer to measure supply and/or return air temperature. If fitted, the port(s) will require a cap and chain.

1.3.16 Water Cooling

The refrigeration system may be fitted with a water-cooled condenser. The condenser is constructed using copper-nickel tube for sea water applications. The water-cooled condenser is in series with the air cooled condenser and replaces the standard unit receiver. When operating on the water-cooled condenser, the condenser fan is deactivated by either a water pressure switch or condenser fan switch.

1.3.17 Back Panels

Aluminum back panels may have access doors and/or hinge mounting.

1.3.18 460 Volt Cable

Various power cable and plug designs are available for the main 460 volt supply. The plug options tailor the cables to each customer's requirements.

1.3.19 230 Volt Cable

Units equipped with an autotransformer require an additional power cable for connection to the 230 volt source. Various power cable and plug designs are available. The plug options tailor the cables to each customer's requirements.

1.3.20 Cable Restraint

Various designs are available for storage of the power cables. These options are variations of the compressor section cable guard.

1.3.21 Upper Air (Fresh Air Make Up)

The unit may be fitted with an upper fresh air makeup assembly. The fresh air makeup assembly is available with a vent positioning sensor (VPS) and may also be fitted with screens.

1.3.22 Lower Air (Fresh Air Make Up)

The unit may be fitted with a lower fresh air makeup assembly. The fresh air makeup assembly is available with a vent positioning sensor (VPS) and may also be fitted with screens.

1.3.23 Evaporator

Evaporator section is equipped with an electronic expansion valve (EEV).

1.3.24 Evaporator Fan Operation

Units are equipped with three-phase evaporator fan motors. Opening of an evaporator fan internal protector will shut down the unit.

1.3.25 Labels

Safety Instruction and Function Code listing labels differ, depending on the options installed. Labels available with additional languages are listed in the parts list.

1.3.26 Plate Set

Each unit is equipped with a tethered set of wiring schematics and wiring diagram plates. The plate sets are ordered using a seven-digit base part number and a two-digit dash number.

1.3.27 Controller

Two different controllers are available:

1. Remanufactured - Controller is the equivalent of a new OEM controller and is supplied with a 12-month warranty.
2. Repaired - Controller has had previous faults repaired and upgraded with the latest software.

Note: Repaired controllers are NOT to be used for warranty repairs; only full OEM Remanufactured controllers are to be used.

Controllers will be factory-equipped with the latest version of operational software, but will NOT be configured for a specific model number and will need to be configured at the time of installation or sale.

1.3.28 Condenser Grille

Two styles of condenser grilles are available: direct bolted grilles and hinged grilles.

SECTION 2

DESCRIPTION

2.1 GENERAL DESCRIPTION

2.1.1 Refrigeration Unit - Front Section

The unit is designed so that the majority of the components are accessible from the front (see Figure 2-1). The unit model number, serial number and parts identification number can be found on the serial plate to the left of the economizer.

2.1.2 Fresh Air Makeup Vent

The function of the upper or lower makeup air vent is to provide ventilation for commodities that require fresh air circulation.

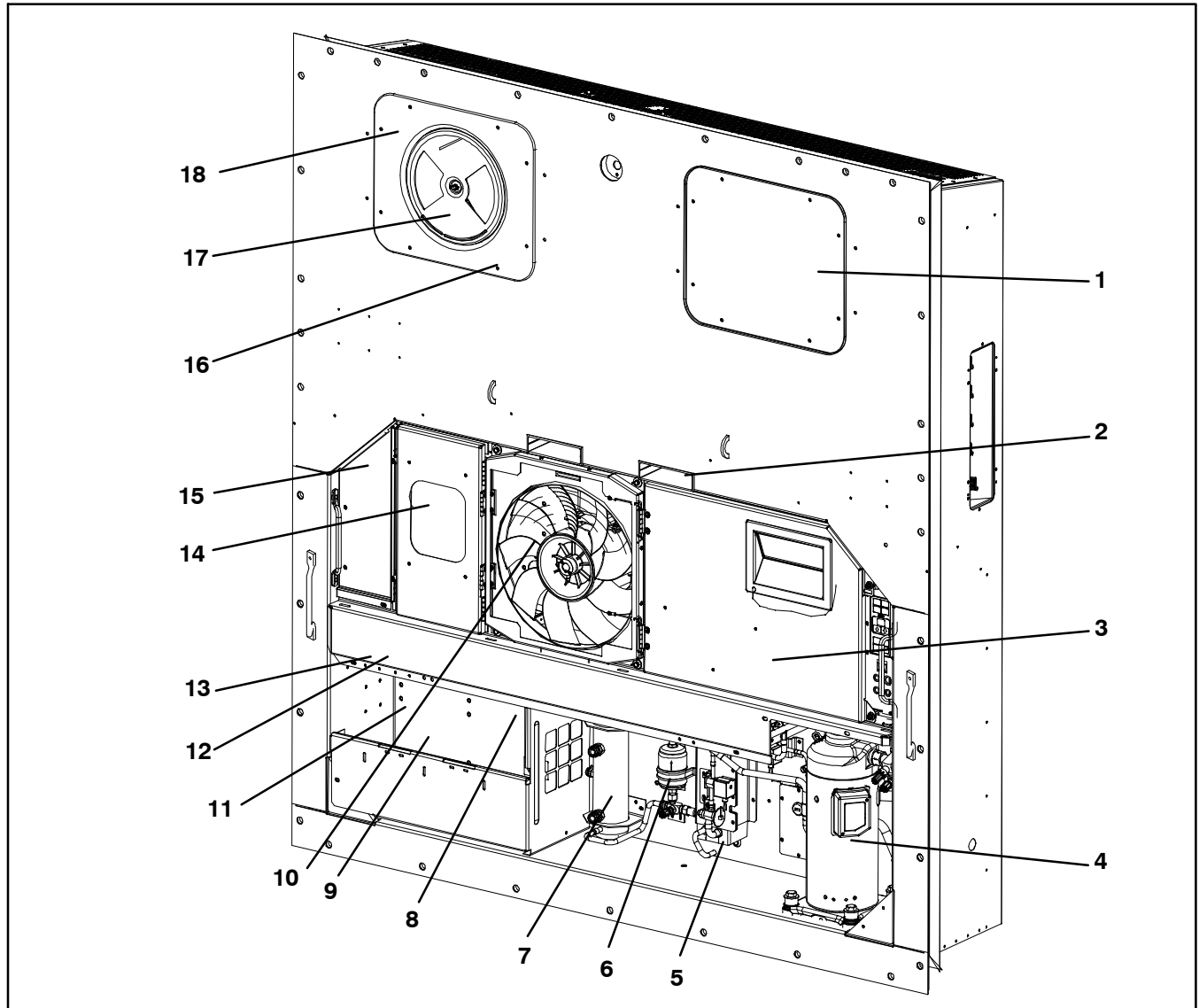

- | | |
|---|--|
| 1. Access Panel (Evap. Fan #1) | 11. Autotransformer (Location) |
| 2. Fork Lift Pockets | 12. TransFRESH Communications Connector |
| 3. Control Box | 13. Interrogator Connector (Front left) |
| 4. Compressor | 14. Temperature Recorder |
| 5. Economizer | 15. Lower Fresh Air Makeup Vent Location (Blank Cover Shown) |
| 6. Filter Drier | 16. TIR (Transports Internationaux Routiers) Sealing Provisions - Typical All Panels |
| 7. Receiver or Water Cooled Condenser | 17. Upper Fresh Air Makeup Vent |
| 8. Unit Serial Number, Model Number and Parts Identification Number (PID) Plate | 18. Access Panel (Evap. Fan #2) |
| 9. Power Cables and Plug (Location) | |
| 10. Condenser Fan | |

Figure 2-1 Refrigeration Unit - Front Section

2.1.3 Evaporator Section

The evaporator section (Figure 2-2) contains the return temperature sensor, humidity sensor, electronic expansion valve, dual speed evaporator fans (EM1 and EM2), evaporator coil and heaters, defrost temperature sensor, heat termination thermostat and evaporator temperature sensors (ETS1 and ETS2).

The evaporator fans circulate air through the container by pulling it in the top of the unit, directing it through the evaporator coil, where it is heated or cooled, and discharging it at the bottom.

Most evaporator components are accessible by removing the upper rear panel (as shown in the illustration) or by removing the front access panels.

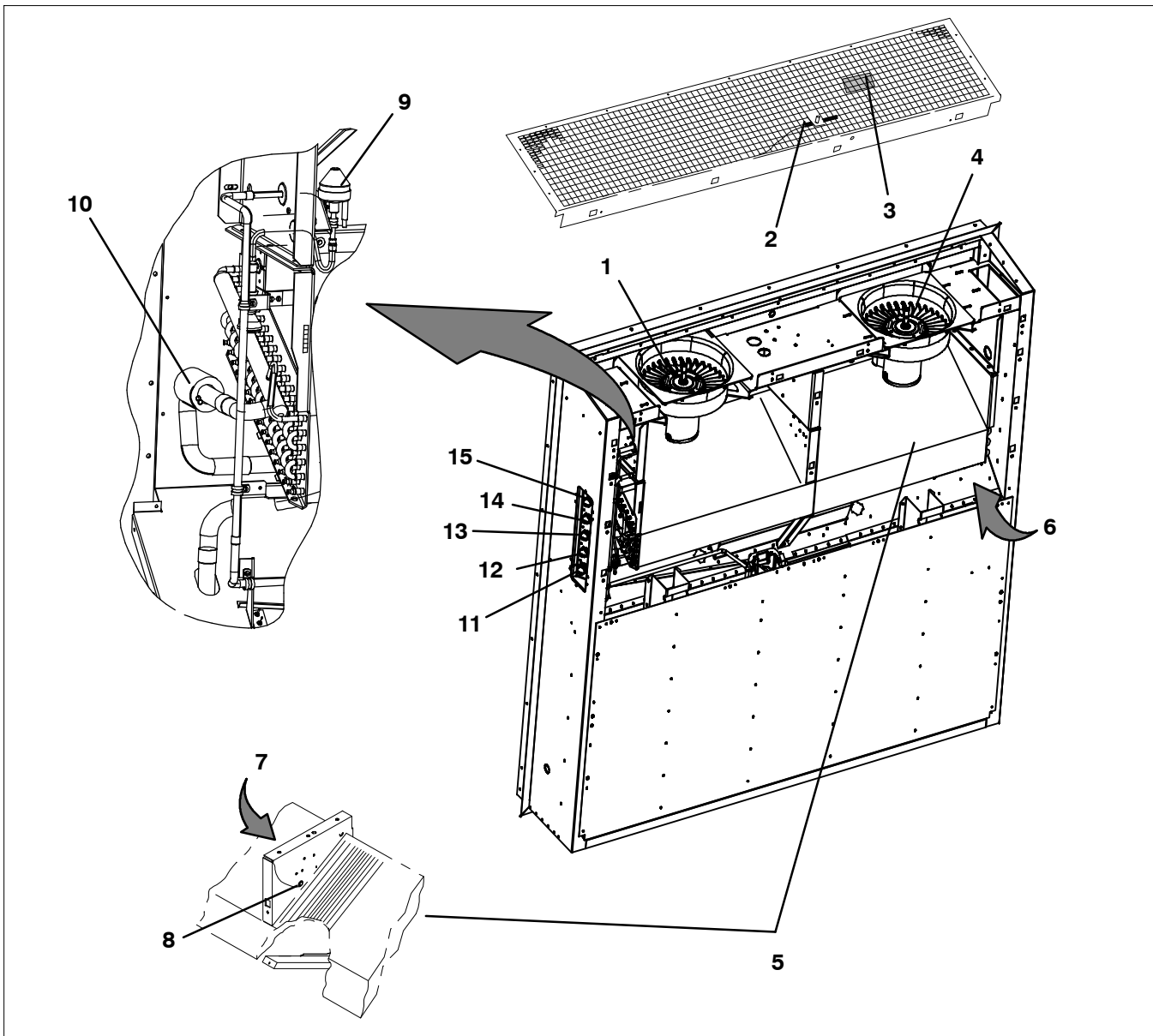

- | | |
|--|---|
| 1. Evaporator Fan Motor #1 (EM1) | 9. Electronic Expansion Valve (EEV) |
| 2. Return Recorder Sensor/Temperature Sensor (RRS/RTS) | 10. Evaporator Temperature Sensors (Location) (ETS1 & ETS2) |
| 3. Humidity Sensor (HS) | 11. Interrogator Connector (Rear) (ICR) |
| 4. Evaporator Fan Motor #2 (EM2) | 12. USDA Probe Receptacle PR2 |
| 5. Evaporator Coil | 13. USDA Probe Receptacle PR1 |
| 6. Evaporator Coil Heaters (Underside of Coil) | 14. USDA Probe Receptacle PR3 |
| 7. Heater Termination Thermostat (HTT) | 15. Cargo Probe Receptacle PR4 |
| 8. Defrost Temperature Sensor (DTS) | |

Figure 2-2 Evaporator Section

2.1.4 Compressor Section

The compressor section includes the compressor, digital unloader valve (DUV), high pressure switch, discharge pressure transducer (DPT), evaporator

pressure transducer (EPT) and the suction pressure transducer (SPT).

The supply temperature sensor, supply recorder sensor and ambient sensor are located to the left of the compressor.

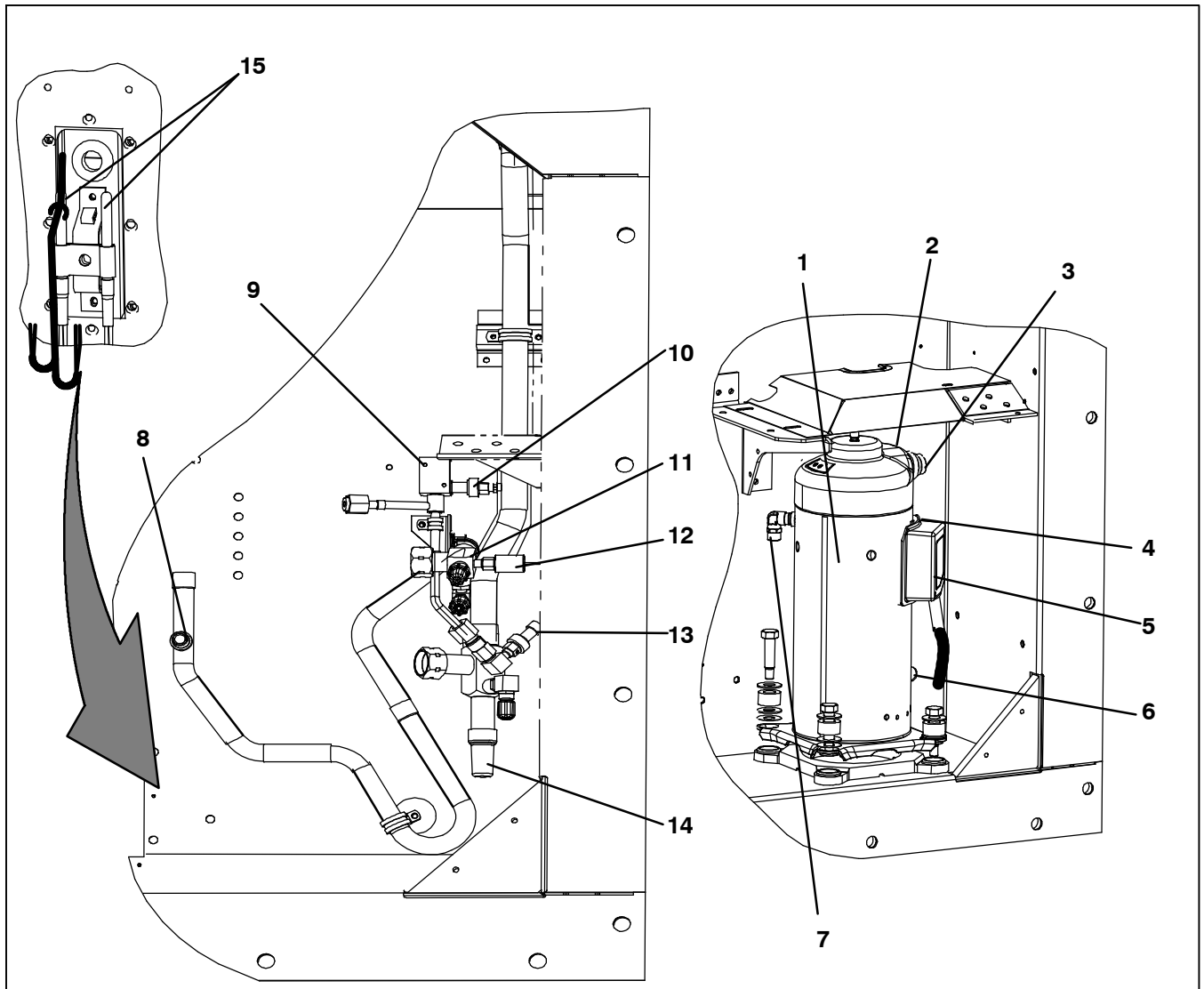

- | | |
|---|--|
| 1. Compressor | 9. Digital Unloader Valve (DUV) |
| 2. Discharge Temperature Sensor (CPDS) (Location) | 10. Evaporator Pressure Transducer (EPT) |
| 3. Discharge Connection | 11. Discharge Service Valve |
| 4. Suction Connection (Location) | 12. High Pressure Switch (HPS) |
| 5. Compressor Terminal Box | 13. Suction Pressure Transducer (SPT) |
| 6. Oil Drain (Location) | 14. Suction Service Valve |
| 7. Economizer Connection | 15. Supply Temperature/Supply Recorder Sensor Assembly (STS/SRS) |
| 8. Discharge Pressure Transducer (DPT) | |

Figure 2-3 Compressor Section

2.1.5 Air-Cooled Condenser Section

The air-cooled condenser section (Figure 2-4) consists of the condenser fan, condenser coil, receiver, liquid line service valve, filter drier, fusible plug, economizer, liquid injection valve (LIV), economizer expansion

valve, economizer solenoid valve (ESV), and sight glass/moisture indicator.

The condenser fan pulls air through the bottom of the coil and discharges it horizontally through the condenser fan grille.

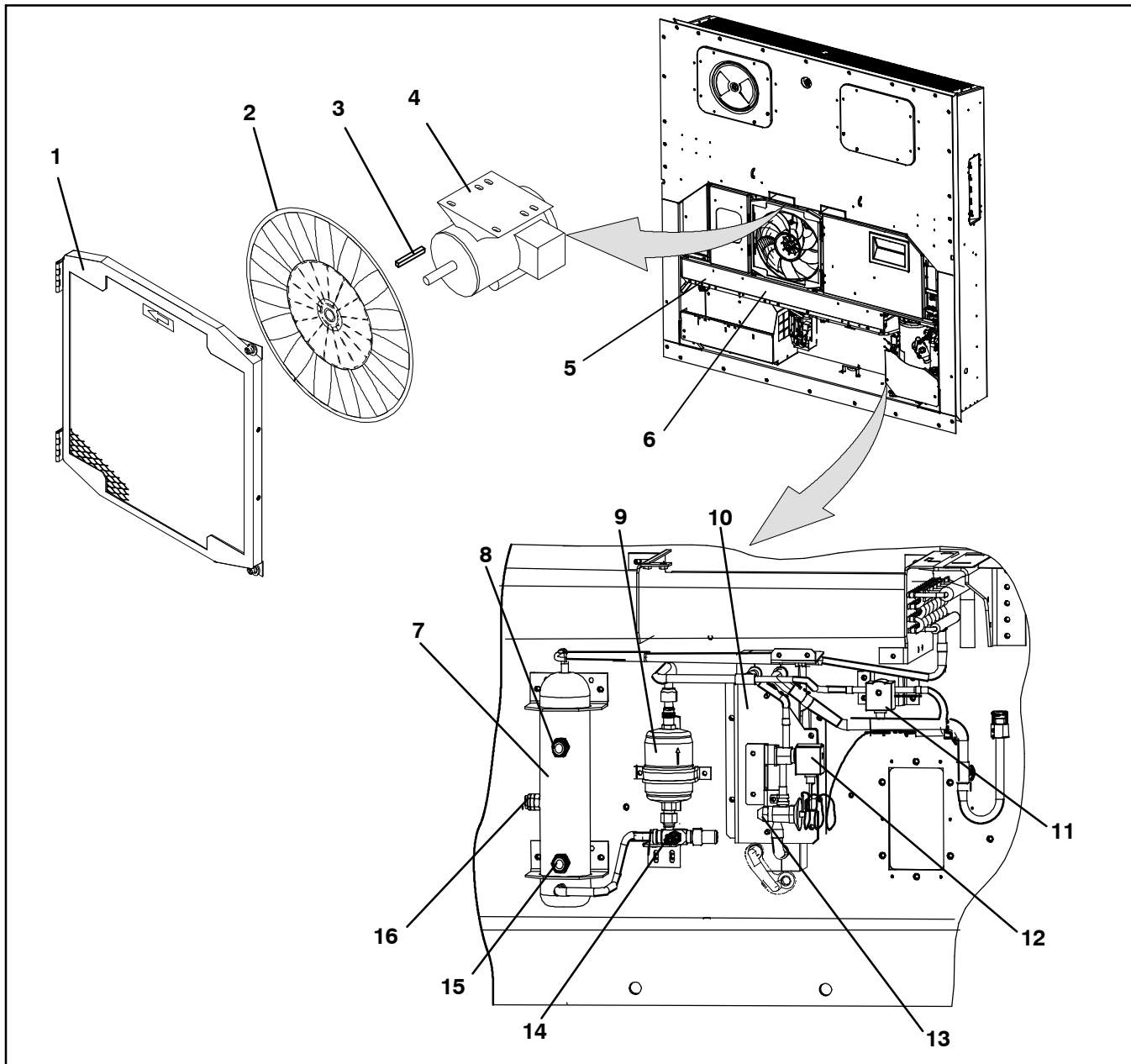

- | | |
|--------------------------------|-------------------------------------|
| 1. Grille and Venturi Assembly | 9. Filter Drier |
| 2. Condenser Fan | 10. Economizer |
| 3. Key | 11. Liquid Injection Valve (LIV) |
| 4. Condenser Fan Motor | 12. Economizer Solenoid Valve (ESV) |
| 5. Condenser Coil | 13. Economizer Expansion Valve |
| 6. Condenser Coil Cover | 14. Service Access Valve |
| 7. Receiver | 15. Sight Glass/Moisture Indicator |
| 8. Sight Glass | 16. Fusible Plug |

Figure 2-4 Air-Cooled Condenser Section

2.1.6 Water-Cooled Condenser Section

The water-cooled condenser section (Figure 2-5) consists of a water-cooled condenser, sight glass, rupture disc, filter drier, water couplings, water pressure switch, economizer, liquid injection valve (LIV), economizer ex-

pansion valve, economizer solenoid valve (ESV), and moisture/liquid indicator.

The water-cooled condenser replaces the standard unit receiver.

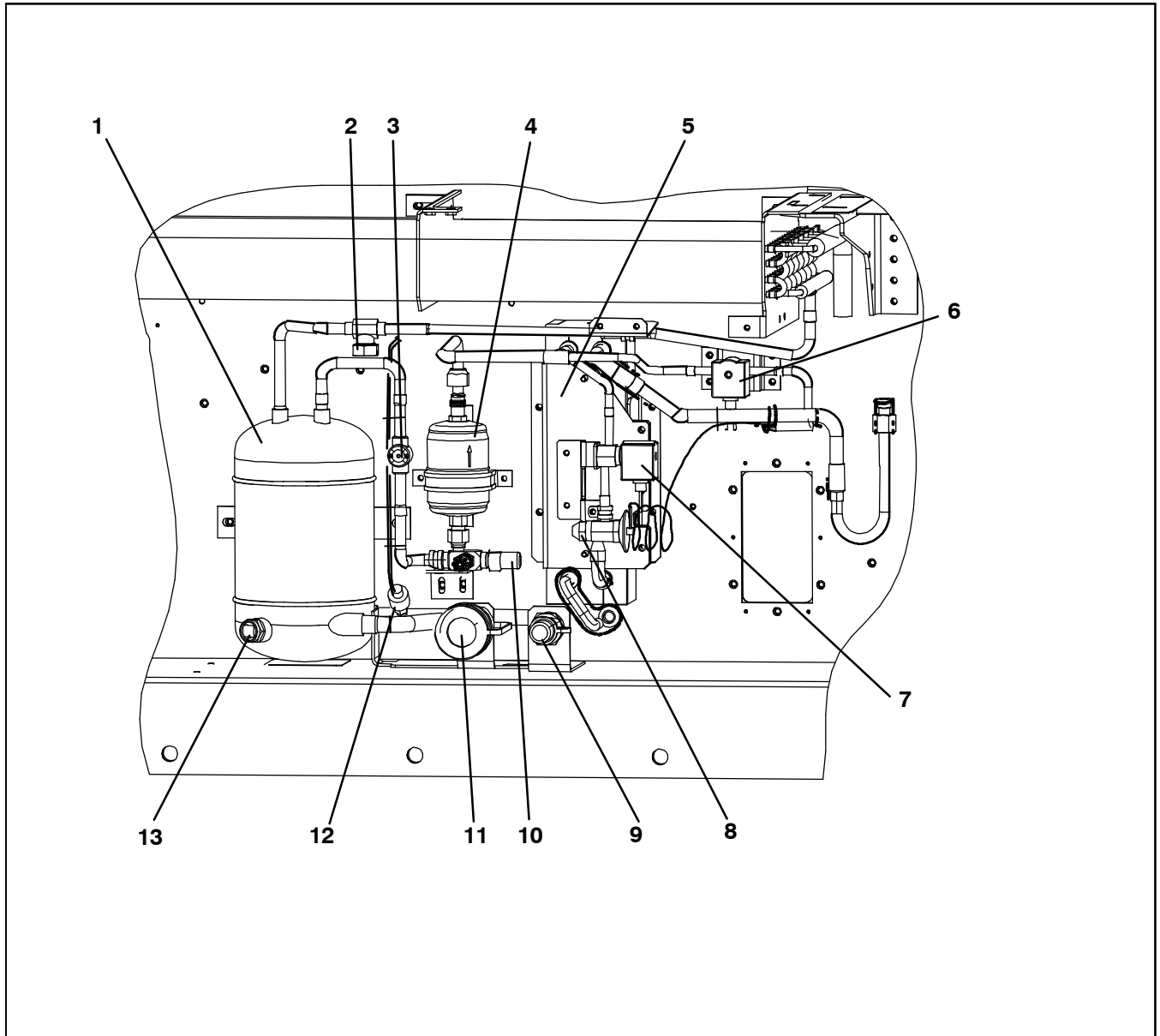

- | | |
|------------------------------------|--|
| 1. Water-Cooled Condenser | 8. Economizer Expansion Valve |
| 2. Rupture Disc | 9. Coupling (Water In) |
| 3. Moisture/Liquid Indicator | 10. Liquid Line Service Valve/Connection |
| 4. Filter Drier | 11. Self Draining Coupling (Water Out) |
| 5. Economizer | 12. Water Pressure Switch (WP) |
| 6. Liquid Injection Valve (LIV) | 13. Sight Glass |
| 7. Economizer Solenoid Valve (ESV) | |

Figure 2-5 Water-Cooled Condenser Section

2.1.7 Control Box Section

The control box (Figure 2-6) includes: the manual operation switches, circuit breaker (CB-1), compressor, fan and heater contactors, control power transformer, fuses, key pad, display module, current sensor module, controller module and the communications interface module.

2.1.8 Communications Interface Module

The communications interface module is a slave module that allows communication with a master central monitoring station. The module will respond to communication and return information over the main power line. Refer to the master system technical manual for further information.

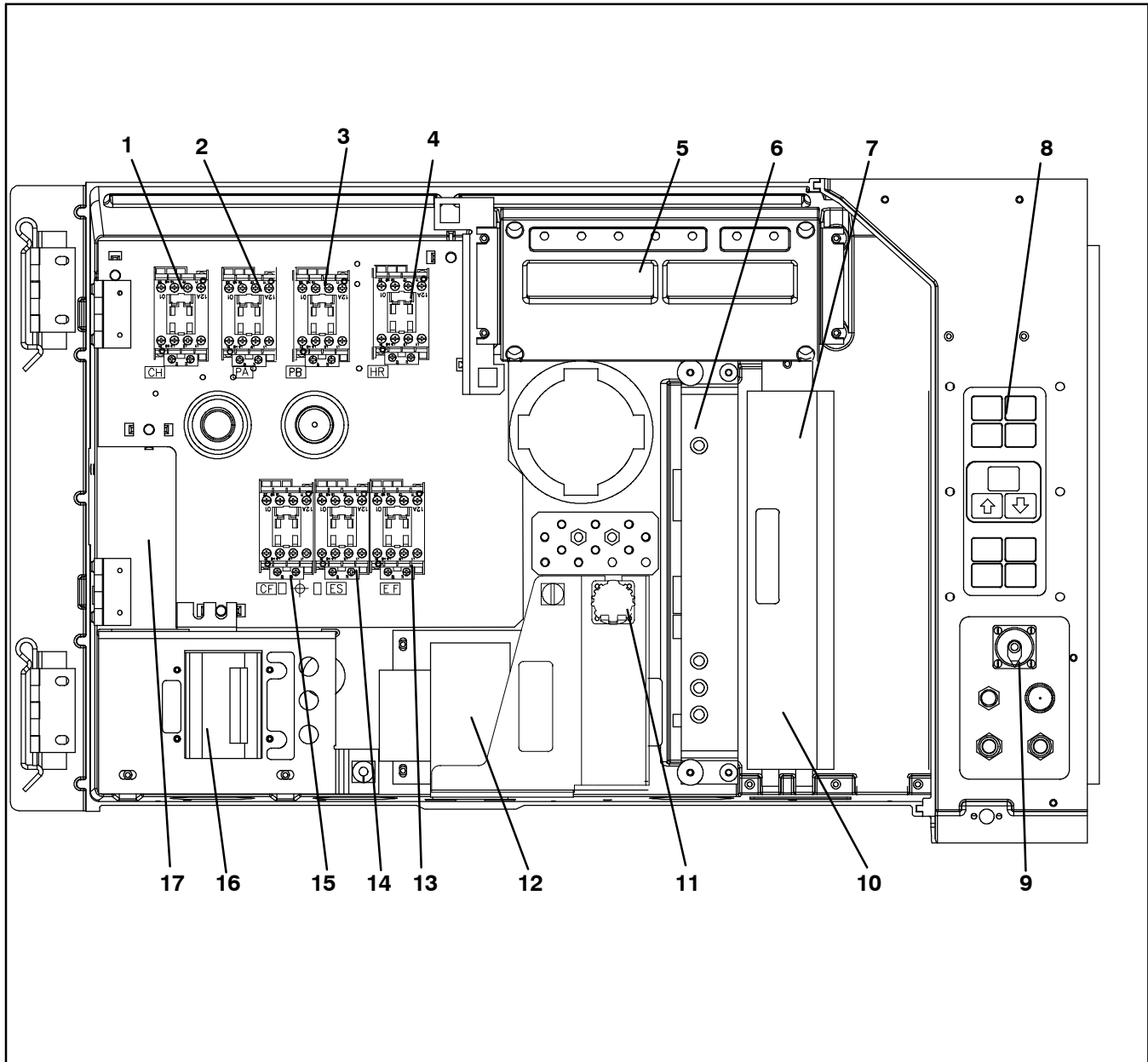

- | | |
|--|---|
| 1. Compressor Contactor - CH | 10. Controller Battery Pack (Standard Location) |
| 2. Compressor Phase A Contactor - PA | 11. Interrogator Connector (Box Location) |
| 3. Compressor Phase B Contactor - PB | 12. Control Transformer |
| 4. Heater Contactor - HR | 13. High Speed Evaporator Fan Contactor - EF |
| 5. Display Module | 14. Low Speed Evaporator Fan Contactor - ES |
| 6. Communications Interface Module | 15. Condenser Fan Contactor - CF |
| 7. Controller/DataCORDER Module (Controller) | 16. Circuit Breaker - 460V |
| 8. Key Pad | 17. Current Sensor Module |
| 9. Remote Monitoring Receptacle | |

Figure 2-6 Control Box Section

2.2 REFRIGERATION SYSTEM DATA

a. Compressor/Motor Assembly	Model Number	ZMD26KVE-TFD-272
	Weight (With Oil)	42.9 kg (95 lb)
	Approved Oil	Uniqema Emkarate RL-32-3MAF
	Oil Charge	1774 ml (60 ounces)
b. Electronic Expansion Valve Superheat (Evaporator)	Verify at -18C (0F) container box temperature	4.4 to 6.7C (8 to 12F)
c. Economizer Expansion Valve Superheat	Verify at -18C (0F) container box temperature	4.4 to 11.1C (8 to 20F)
d. Heater Termination Thermostat	Opens	54 (+/- 3) C = 130 (+/- 5) F
	Closes	38 (+/- 4) C = 100 (+/- 7) F
e. High Pressure Switch	Cutout	25 (+/- 1.0) kg/cm ² = 350 (+/- 10) psig
	Cut-In	18 (+/- 0.7) kg/cm ² = 250 (+/- 10) psig
f. Refrigerant Charge	Unit Configuration	Charge Requirements - R-134a (Compressors are shipped with factory charge)
	Water-Cooled Condenser	5.67 kg (12.5 lbs)
	Receiver	5.22 kg (11.5 lbs)
g. Fusible Plug	Melting point	99C = (210F)
	Torque	6.2 to 6.9 mkg (45 to 50 ft-lbs)
h. Rupture Disc	Bursts at	35 +/- 5% kg/cm ² = (500 +/- 5% psig)
	Torque	6.2 to 6.9 mkg (45 to 50 ft-lbs)
i. Unit Weight	Refer to unit model number plate.	
j. Water Pressure Switch	Cut-In	0.5 +/- 0.2 kg/cm ² (7 +/- 3 psig)
	Cutout	1.6 +/- 0.4 kg/cm ² (22 +/- 5 psig)

2.3 ELECTRICAL DATA

a. Circuit Breaker	CB-1 Trips at	29 amps	
	CB-2 (50 amp) Trips at	62.5 amps	
	CB-2 (70 amp) Trips at	87.5 amps	
b. Compressor Motor	Full Load Amps (FLA)	13 amps @ 460 VAC	
c. Condenser Fan Motor		380 VAC, Single Phase, 50 Hz	460 VAC, Single Phase, 60 Hz
	Full Load Amps	1.3 amps	1.6 amps
	Horsepower	0.43 hp	0.75 hp
	Rotations Per Minute	1425 rpm	1725 rpm
	Voltage and Frequency	360 - 460 VAC +/- 2.5 Hz	400 - 500 VAC +/- 2.5 Hz
	Bearing Lubrication	Factory lubricated, additional grease not required.	
	Rotation	Counter-clockwise when viewed from shaft end.	
d. Evaporator Coil Heaters	Number of Heaters	6	
	Rating	750 watts +/-10% each @ 230 VAC	
	Resistance (cold)	66.8 to 77.2 ohms @ 20C (68F)	
	Type	Sheath	
e. Evaporator Fan Motor(s)		380 VAC/3 PH/50 Hz	460 VAC/3 PH/60 Hz
	Full Load Amps High Speed	1.0	1.2
	Full Load Amps Low Speed	0.6	0.6
	Nominal Horsepower High Speed	0.49	0.84
	Nominal Horsepower Low Speed	0.06	0.11
	Rotations Per Minute High Speed	2850 rpm	3450 rpm
	Rotations Per Minute Low Speed	1425 rpm	1725 rpm
	Voltage and Frequency	360 - 460 VAC +/- 1.25 Hz	400 - 500 VAC +/- 1.5 Hz
	Bearing Lubrication	Factory lubricated, additional grease not required	
	Rotation	CW when viewed from shaft end	
f. Fuses	Control Circuit	7.5 amps (F3A,F3B)	
	Controller/DataCORDER	5 amps (F1 & F2)	
g. Vent Positioning Sensor	Electrical Output	0.5 VDC to 4.5 VDC over 90 degree range	
	Supply Voltage	5 VDC +/- 10%	
	Supply Current	5 mA (typical)	
h. Solenoid Valve Coils (ESV, LIV) 24 VDC	Nominal Resistance @ 77F (25C)	7.7 ohms +/- 5%	
	Maximum Current Draw	0.7 amps	
i. DUV Coils 12 VDC	Nominal Resistance @ 77F (20C)	14.8 ohms +/- 5%	
	Maximum Current Draw	929 mA	
j. EEV Nominal Resistance	Coil Feed to Ground (Gray Wire)	47 ohms	
	Coil Feed to Coil Feed	95 ohms	

Section 2.3 - ELECTRICAL DATA-CONTINUED

k. Humidity Sensor	Orange wire	Power
	Red wire	Output
	Brown wire	Ground
	Input voltage	5 VDC
	Output voltage	0 to 3.3 VDC
	Output voltage readings versus relative humidity (RH) percentage:	
	30%	0.99 V
	50%	1.65 V
	70%	2.31 V
	90%	2.97 V

2.4 SAFETY AND PROTECTIVE DEVICES

Unit components are protected from damage by safety and protective devices listed in Table 2-1. These devices monitor the unit operating conditions and open a set of electrical contacts when an unsafe condition occurs.

Open safety switch contacts on either or both of devices

IP-CP or HPS will shut down the compressor.

Open safety switch contacts on device IP-CM will shut down the condenser fan motor.

The entire refrigeration unit will shut down if one of the following safety devices open: (a) circuit breaker(s); (b) fuse (F3A/F3B, 7.5A); or (c) evaporator fan motor internal protector(s) - (IP).

Table 2-1 Safety and Protective Devices

UNSAFE CONDITION	DEVICE	DEVICE SETTING
Excessive current draw	Circuit Breaker (CB-1) - Manual Reset	Trips at 29 amps (460 VAC)
	Circuit Breaker (CB-2, 50 amp) - Manual Reset	Trips at 62.5 amps (230 VAC)
	Circuit Breaker (CB-2, 70 amp) - Manual Reset	Trips at 87.5 amps (230 VAC)
Excessive current draw in the control circuit	Fuse (F3A & F3B)	7.5 amp rating
Excessive current draw by the controller	Fuse (F1 & F2)	5 amp rating
Excessive condenser fan motor winding temperature	Internal Protector (IP-CM) - Automatic Reset	N/A
Excessive compressor motor winding temperature	Internal Protector (IP-CP) - Automatic Reset	N/A
Excessive evaporator fan motor(s) winding temperature	Internal Protector(s) (IP-EM) - Automatic Reset	N/A
Abnormal pressures/temperatures in the high refrigerant side	Fusible Plug - Used on the Receiver	99C = (210F)
	Rupture Disc - Used on the Water-Cooled Condenser	35 kg/cm ² = (500 psig)
Abnormally high discharge pressure	High Pressure Switch (HPS)	Opens at 25 kg/cm ² (350 psig)

2.5 REFRIGERATION CIRCUIT

2.5.1 Standard Operation

Starting at the compressor, (see Figure 2-7, upper schematic) the suction gas is compressed to a higher pressure and temperature.

In the standard mode, the economizer valve is closed.

The refrigerant gas flows through the discharge line and continues into the air-cooled condenser. When operating with the air-cooled condenser active, air flowing across the coil fins and tubes cools the gas to saturation temperature. By removing latent heat, the gas condenses to a high pressure/high temperature liquid and flows to the receiver, which stores the additional charge necessary for low temperature operation.

When operating with the water-cooled condenser active (see Figure 2-7, lower schematic), the refrigerant gas passes through the air-cooled condenser and enters the water-cooled condenser shell. The water flowing inside the tubing cools the gas to saturation temperature in the same manner as the air passing over the air-cooled condenser. The refrigerant condenses on the outside of the tubes and exits as a high temperature liquid. The water-cooled condenser also acts as a receiver, storing excess refrigerant.

The liquid refrigerant continues through the liquid line, the filter drier (which keeps refrigerant clean and dry) and the economizer (which is not active during standard operation) to the electronic expansion valve. As the liquid refrigerant passes through the variable orifice of the expansion valve, some of it vaporizes into a gas (flash gas). Heat is absorbed from the return air by the balance of the liquid, causing it to vaporize in the evaporator coil. The vapor then flows through the suction tube back to the compressor.

On systems fitted with a water pressure switch, the condenser fan will be off when there is sufficient pressure to open the switch. If water pressure drops below the switch cut out setting, the condenser fan will automatically start. When operating a system fitted with a condenser fan switch, the condenser fan will be off when the switch is placed in the "O" position. The condenser fan will be on when the switch is placed in the "I" position.

During the standard mode of operation, the normally closed digital unloader valve (DUV) controls the system refrigerant flow and capacity by loading and unloading

the compressor in frequent discrete time intervals. If the system capacity has been decreased to the lowest allowable capacity with the DUV, the unit will enter a trim heat mode of operation, during which the controller will pulse the evaporator heaters in sequence with the compressor digital signal in order to absorb the excess capacity.

2.5.2 Economized Operation

In the economized mode, (see Figure 2-8) the frozen and pull down capacity of the unit is increased by sub-cooling the liquid refrigerant entering the electronic expansion valve. Overall efficiency is increased because the gas leaving the economizer enters the compressor at a higher pressure, therefore requiring less energy to compress it to the required condensing conditions.

Liquid refrigerant for use in the economizer circuit is taken from the main liquid line as it leaves the filter drier. The flow is activated when the controller energizes the economizer solenoid valve (ESV).

The liquid refrigerant flows through the economizer expansion valve and the economizer internal passages absorbing heat from the liquid refrigerant flowing to the electronic expansion valve. The resultant "medium" temperature/pressure gas enters the compressor at the economizer port fitting.

When the air temperature falls to 2.5 C (4.5 F) above set point, the DUV unloads the compressor's scroll and begins to reduce the capacity of the unit. Percentage of the unit capacity is accessed through code select 01 (Cd01). For example, if Cd01 displays 70, it indicates that the compressor is operating unloaded with the DUV engaged 30% of the time.

2.5.3 Liquid Injection Valve

The normally closed liquid injection valve (LIV) will open and close to cool the compressor and prevent it from overheating.

2.5.4 Electronic Expansion Valve

The microprocessor controls the superheat leaving the evaporator via the electronic expansion valve (EEV), based on inputs from the evaporator temperature sensor (ETS) and the evaporator pressure transducer (EPT). The microprocessor transmits electronic pulses to the EEV stepper motor, which opens or closes the valve orifice to maintain the superheat setpoint.

STANDARD OPERATION WITH RECEIVER

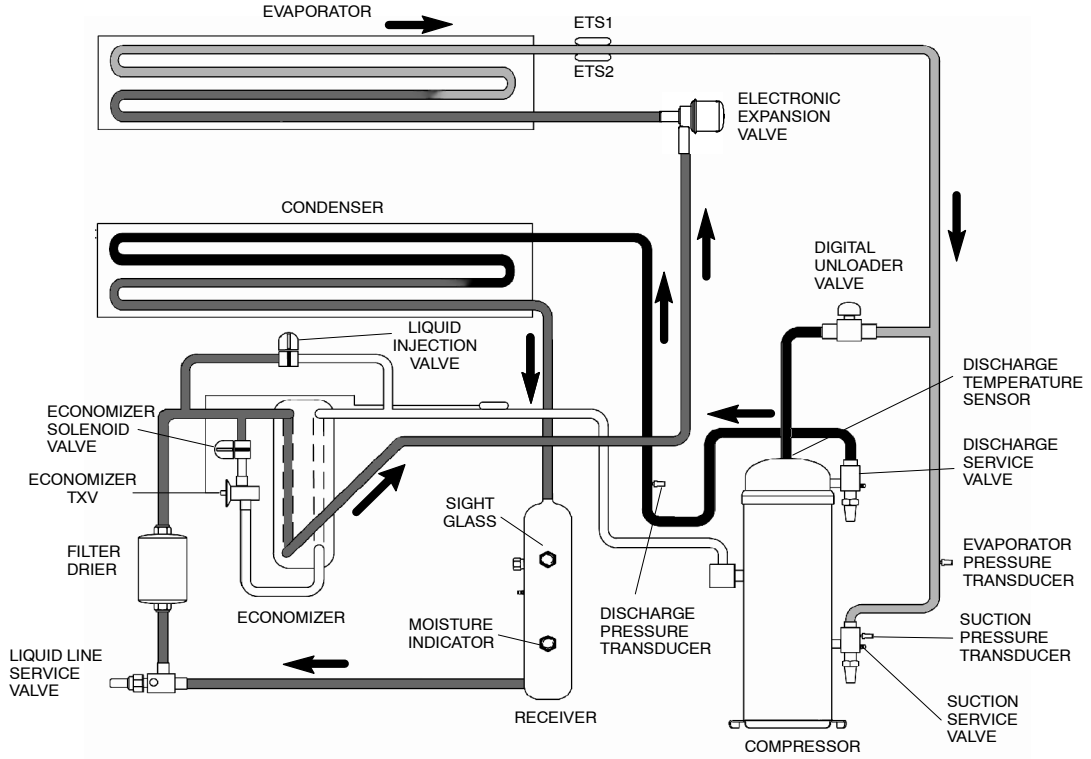

STANDARD OPERATION WITH WATER-COOLED CONDENSER

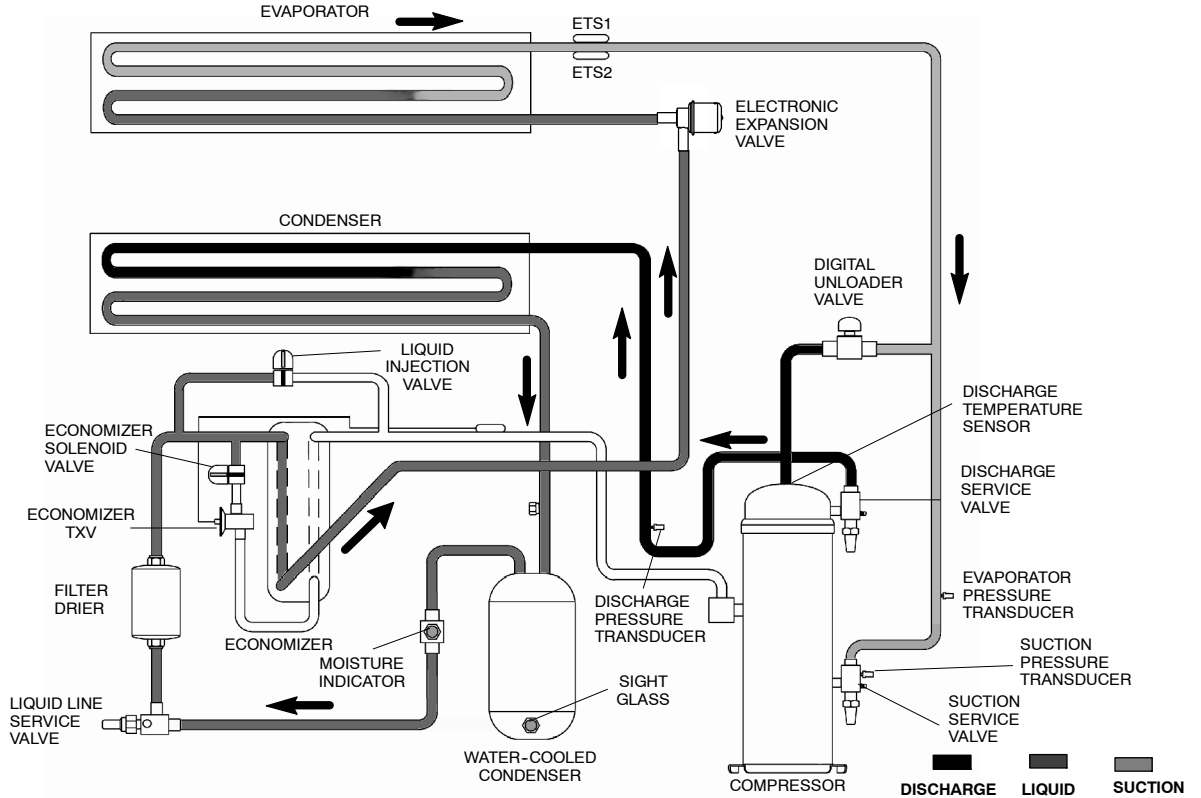

Figure 2-7 Refrigeration Circuit Schematic - Standard Operation

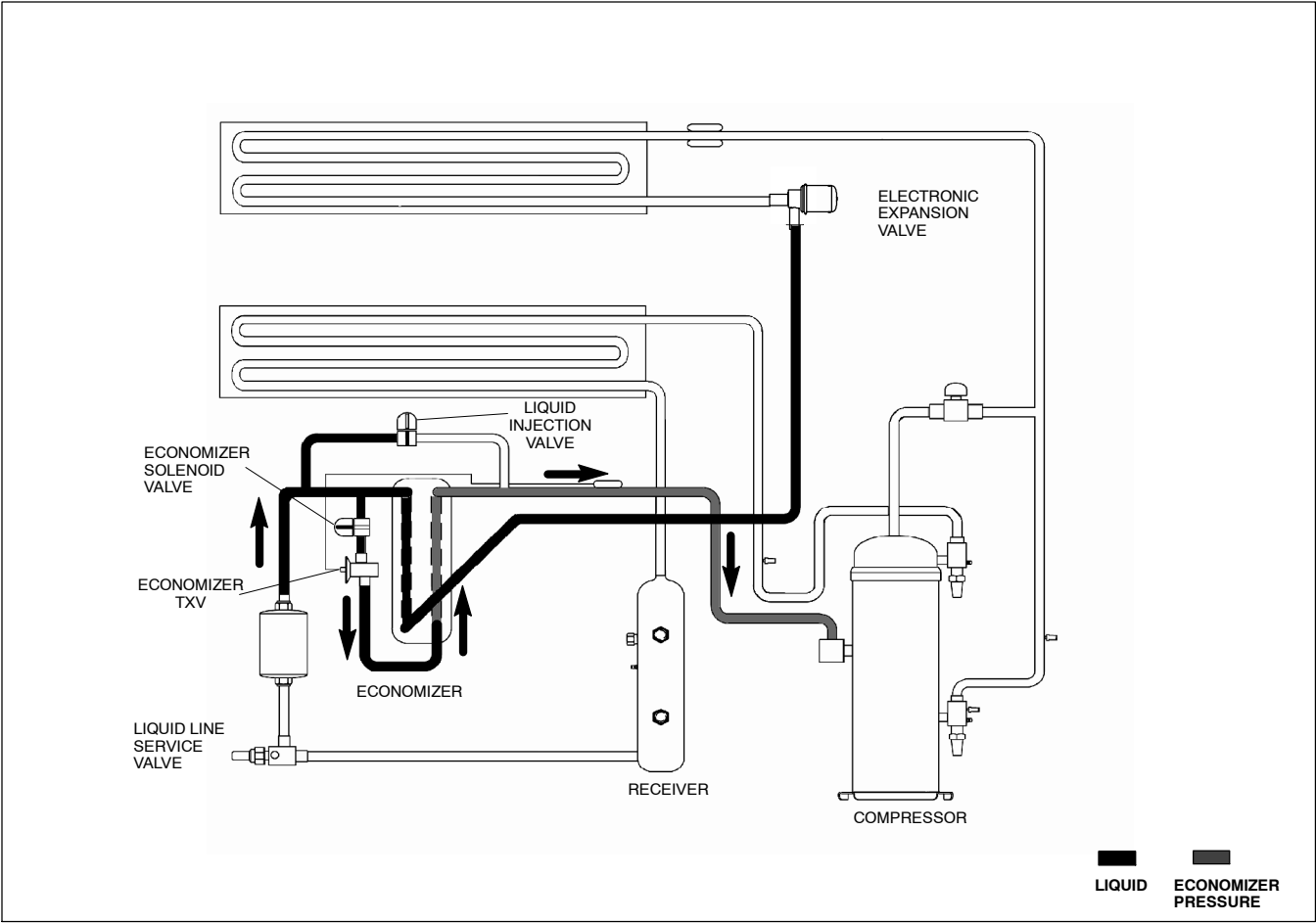

Figure 2-8 Refrigeration Circuit Schematic - Economized Operation

SECTION 3 MICROPROCESSOR

3.1 TEMPERATURE CONTROL MICROPROCESSOR SYSTEM

The temperature control Micro-Link 3 microprocessor system (see Figure 3-1) consists of a keypad, display module, the control module (controller) and interconnecting wiring. The controller houses the temperature control software and the DataCORDER software. The temperature control software functions to operate the unit components as required to provide the desired cargo temperature and humidity. The DataCORDER software functions to record unit

operating parameters and cargo temperature parameters for future retrieval. Coverage of the temperature control software begins with paragraph 3.2. Coverage of the DataCORDER software is provided in paragraph 3.7.

The keypad and display module serve to provide user access and readouts for both of the controller functions, temperature control and DataCORDER. The functions are accessed by keypad selections and viewed on the display module. The components are designed to permit ease of installation and removal.

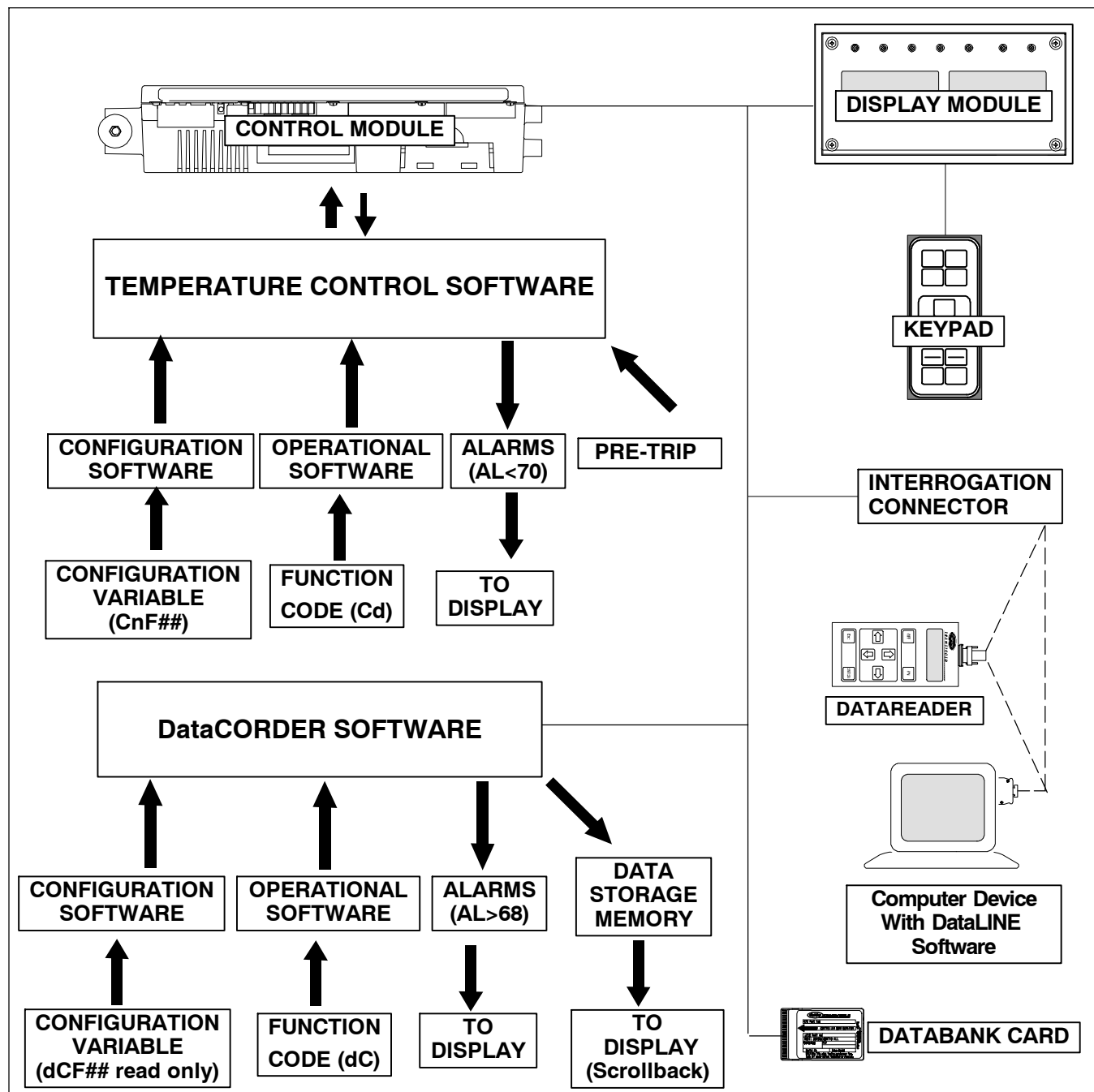
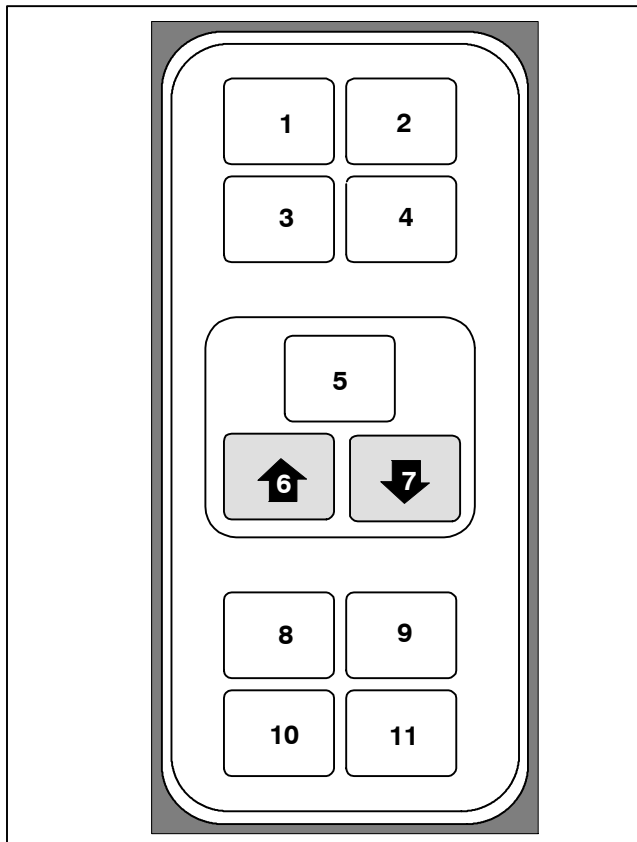

Figure 3-1 Temperature Control System

3.1.1 Keypad

The keypad (Figure 3-2) is mounted on the right-hand side of the control box. The keypad consists of eleven push button switches that act as the user's interface with the controller. Descriptions of the switch functions are provided in Table 3-1.



- | | |
|--------------------------------|-----------------------|
| 1. Code Select | 6. UP Arrow |
| 2. Pre-Trip | 7. DOWN Arrow |
| 3. Alarm List | 8. Return/Supply |
| 4. Manual Defrost/
Interval | 9. Celsius/Fahrenheit |
| 5. ENTER | 10. Battery Power |
| | 11. Alt. Mode |

Figure 3-2 Keypad

3.1.2 Display Module

The display module (Figure 3-3) consists of two 5-digit displays and seven indicator lights. The indicator lights include:

1. Cool - White LED: Energized when the refrigerant compressor is energized.
2. Heat - Orange LED: Energized to indicate heater operation in the heat or defrost mode.
3. Defrost - Orange LED: Energized when the unit is in the defrost mode.
4. In-Range - Green LED: Energized when the controlled temperature probe is within specified tolerance of set point.

NOTE

The controlling probe in the perishable range will be the SUPPLY air probe and the controlling probe in the frozen range will be the RETURN air probe.

Table 3-1 Keypad Function

KEY	FUNCTION
Code Select	Accesses function codes.
Pre-Trip	Displays the pre-trip selection menu. Discontinues pre-trip in progress.
Alarm List	Displays alarm list and clears the alarm queue.
Manual Defrost/ Interval	Displays selected defrost mode. Depressing and holding the Defrost interval key for five (5) seconds will initiate defrost using the same logic as if the optional manual defrost switch was toggled on.
Enter	Confirms a selection or saves a selection to the controller.
Arrow Up	Change or scroll a selection upward Pre-trip advance or test interruption.
Arrow Down	Change or scroll a selection downward. Pre-trip repeat backward.
Return/ Supply	Displays non-controlling probe temperature (momentary display).
Celsius / Fahrenheit	Displays alternate English/Metric scale (momentary display). When set to F, pressure is displayed in psig and vacuum in "/hg." "P" appears after the value to indicate psig and "I" appears for inches of mercury. When set to C, pressure readings are in bars. "b" appears after the value to indicate bars.
Battery Power	Initiate battery backup mode to allow set point and function code selection if AC power is not connected.
ALT. Mode	This key is pressed to switch the functions from the temperature software to the DataCORDER Software. The remaining keys function the same as described above except the readings or changes are made to the DataCORDER programming.

5. Supply - Yellow LED: Energized when the supply air probe is used for control. When this LED is illuminated, the temperature displayed in the AIR TEMPERATURE display is the reading at the supply air probe. This LED will flash if dehumidification or humidification is enabled.
6. Return - Yellow LED: Energized when the return air probe is used for control. When this LED is illuminated, the temperature displayed in the AIR TEMPERATURE display is the reading at the return air probe. This LED will flash if dehumidification or humidification is enabled.
7. Alarm - Red LED: Energized when there is an active or an inactive shutdown alarm in the alarm queue.

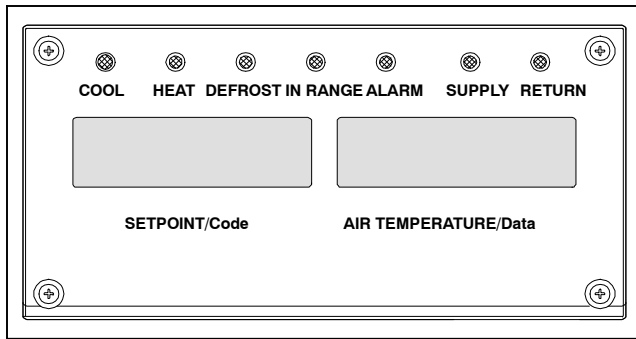

Figure 3-3 Display Module

3.1.3 Controller

CAUTION

Do not remove wire harnesses from controller modules unless you are grounded to the unit frame with a static safe wrist strap.

CAUTION

Unplug all controller module wire harness connectors before performing arc welding on any part of the container.

CAUTION

Do not attempt to use an ML2i PC card in an ML3 equipped unit. The PC cards are physically different and will result in damage to the controller.

NOTE

Do not attempt to service the controller modules. Breaking the seal will void the warranty.

The Micro-Link 3 controller is a dual module microprocessor as shown in Figure 3-4. It is fitted with test points, harness connectors and a software card programming port.

3.2 CONTROLLER SOFTWARE

The controller software is a custom designed program that is subdivided into configuration software and operational software. The controller software performs the following functions:

- a. Control supply or return air temperature to required limits, provide modulated refrigeration operation, economized operation, unloaded operation, electric heat control and defrost. Defrost is performed to clear buildup of frost and ice and ensure proper air flow across the coil.
- b. Provide default independent readouts of set point and supply or return air temperatures.
- c. Provide ability to read and (if applicable) modify the configuration software variables, operating software Function Codes and Alarm Code indications.
- d. Provide a Pre-Trip step-by-step checkout of refrigeration unit performance including: proper component operation, electronic and refrigeration control operation, heater operation, probe calibration, pressure limiting and current limiting settings.
- e. Provide battery-powered ability to access or change selected codes and set point without AC power connected.
- f. Provide the ability to reprogram the software through the use of a memory card.

3.2.1 Configuration Software (Variables)

The configuration software is a variable listing of the components available for use by the operational software. This software is factory installed in accordance with the equipment fitted and options listed on the original purchase order. Changes to the configuration software are required only when a new controller has been installed or a physical change has been made to the unit such as the addition or removal of an option. A configuration variable list is provided in Table 3-4. Change to the factory-installed configuration software is achieved via a configuration card or by communications.

3.2.2 Operational Software (Function Codes)

The operational software is the actual operation programming of the controller which activates or deactivates components in accordance with current unit operating conditions and operator selected modes of operation.

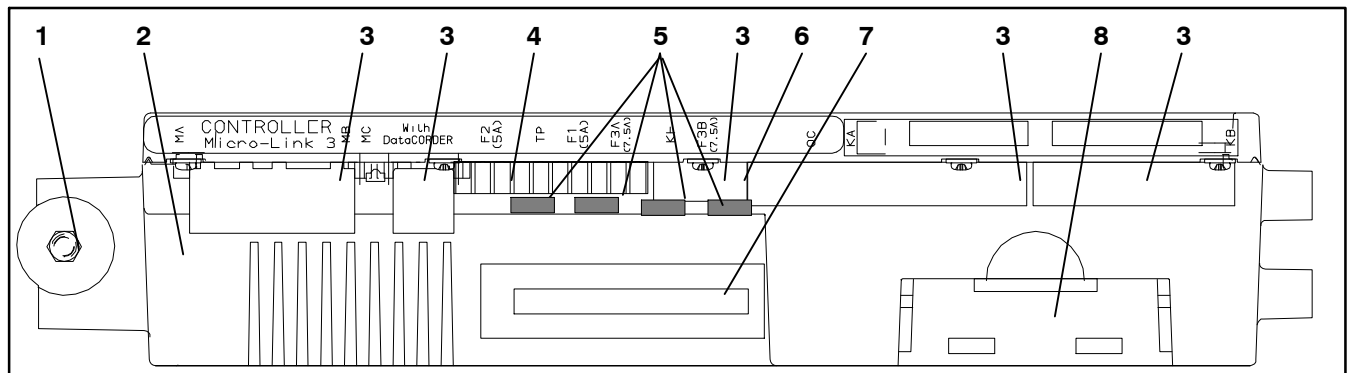

- | | |
|---|-------------------------------------|
| 1. Mounting Screw | 5. Fuses |
| 2. Micro-Link 3 Control/DataCORDER Module | 6. Control Circuit Power Connection |
| 3. Connectors | 7. Software Programming Port |
| 4. Test Points | 8. Battery Pack (Standard Location) |

Figure 3-4 Control Module

The programming is divided into function codes. Some of the codes are read only while the remaining codes may be user configured. The value of the user configurable codes can be assigned in accordance with user desired mode of operation. A list of the function codes is provided in Table 3-5.

To access the function codes, perform the following:

- a. Press the CODE SELECT key, then press an arrow key until the left window displays the desired code number.
- b. The right window will display the value of this item for five seconds before returning to the normal display mode.
- c. If a longer time is desired, press the ENTER key to extend the time to five minutes.

3.3 CONTROLLER SEQUENCE AND MODES OF OPERATION

General operation sequences for cooling, heating and defrost are provided in the following subparagraphs. Schematic representation of controller action is provided in Figure 3-5.

The operational software responds to various inputs. These inputs come from the temperature and pressure sensors, the temperature set point, the settings of the configuration variables and the function code assignments. The action taken by the operational software will change if any one of the inputs change. Overall interaction of the inputs is described as a "mode" of operation. The modes of operation include perishable (chill) mode and frozen mode. Descriptions of the controller interaction and modes of operation are provided in the following sub paragraphs.

3.3.1 Start up - Compressor Phase Sequence

The controller logic will check for proper phase sequencing and compressor rotation. If sequencing is allowing the compressor and three-phase evaporator fan motor to rotate in the wrong direction, the controller will energize or de-energize relay TCP as required (see Figure 7-2). Relay TCP will switch its contacts, energizing or de-energizing relays PA and PB. Relay PA is wired to energize the circuit(s) on L1, L2 and L3. Relay PB is wired to energize the circuit(s) on L3, L2, and L1, thus providing reverse rotation.

3.3.2 Start up - Compressor Bump Start

The controller logic will initiate a compressor bump start procedure to clear refrigerant from the compressor. If the unit has been without power for four hours or if suction and discharge pressures have equalized, the compressor will perform three compressor bump starts. The EEV will close. Relays TS, TQ, TN, TE, TV will be de-energized (opened). The result of this action will close the ESV, LIV, and shut all fans off. The compressor will start for 1 second, then pause for five seconds. This sequence will be repeated two additional times. After the final bump start the unit will pre-position the EEV to correct starting position pause and startup.

3.3.3 Perishable Set Point Temperature - Perishable Pulldown

When cooling from a temperature that is more than 2.5C (4.5F) above set point, the system will be in the perishable pulldown mode. It will be in economized operation. However, pressure and current limit

functions may restrict the valve if either exceeds the preset value.

3.3.4 Perishable Set Point Temperature - Conventional Temperature Control Mode

The unit is capable of maintaining supply air temperature to within +/-0.25C (+/-0.5F) of set point. Supply air temperature is controlled by positioning of the electronic expansion valve (EEV), cycling of the compressor and cycling of the heaters.

Once set point is reached, the unit will transition to the perishable steady state mode. This results in unloaded operation.

If the controller has determined that cooling is not required or the controller logic determines suction pressure is at the low pressure limit, the unit will transition to the perishable idle mode. The compressor is turned off and the evaporator fans continue to run to circulate air throughout the container. If temperature rises above set point +0.2C, the unit will transition back to the perishable steady state mode

If the temperature drops to 0.5C (0.9F) below set point, the unit will transition to the perishable heating mode and the heaters will be energized. The unit will transition back to the perishable idle mode when the temperature rises to 0.2C (0.4F) below the set point and the heaters will de-energize.

3.3.5 Perishable Set Point Temperature - Economy Mode

The economy mode is an extension of the conventional mode. The mode is activated when the setting of function code Cd34 is "ON." Economy mode is provided for power saving purposes. Economy mode could be utilized in the transportation of temperature-tolerant cargo or non-respiration items which do not require high airflow for removing respiration heat. There is no active display indicator that economy mode has been activated. To check for economy mode, perform a manual display of code Cd34.

In order to achieve economy mode, a perishable set point must be selected prior to activation. When economy mode is active, the evaporator fans will be controlled as follows:

At the start of each cooling or heating cycle, the evaporator fans will run in high speed for three minutes. They will then be switched to low speed any time the supply air temperature is within +/- 0.25C (0.45F) of the set point and the return air temperature is less than or equal to the supply air temperature +3C (5.4F). The fans will continue to run in low speed for one hour. At the end of the hour, the evaporator fans will switch back to high speed and the cycle will be repeated. If bulb mode is active, the economy fan activity will be overridden.

3.3.6 Perishable Set Point Temperature Control

With configuration variable CnF26 (Heat Lockout Temperature) set to -10C the perishable mode of operation is active with set points *above* -10C (+14F). With the variable set to -5C, the perishable mode is active *above* -5C (+23F). Refer to Table 3-4.

When in the perishable mode, the controller maintains the supply air temperature at set point, the SUPPLY indicator light will be illuminated on the display module and the default reading on the display window will be the supply temperature sensor reading.

When the supply air temperature enters the in-range temperature tolerance (as selected at function code Cd30), the in-range light will energize.

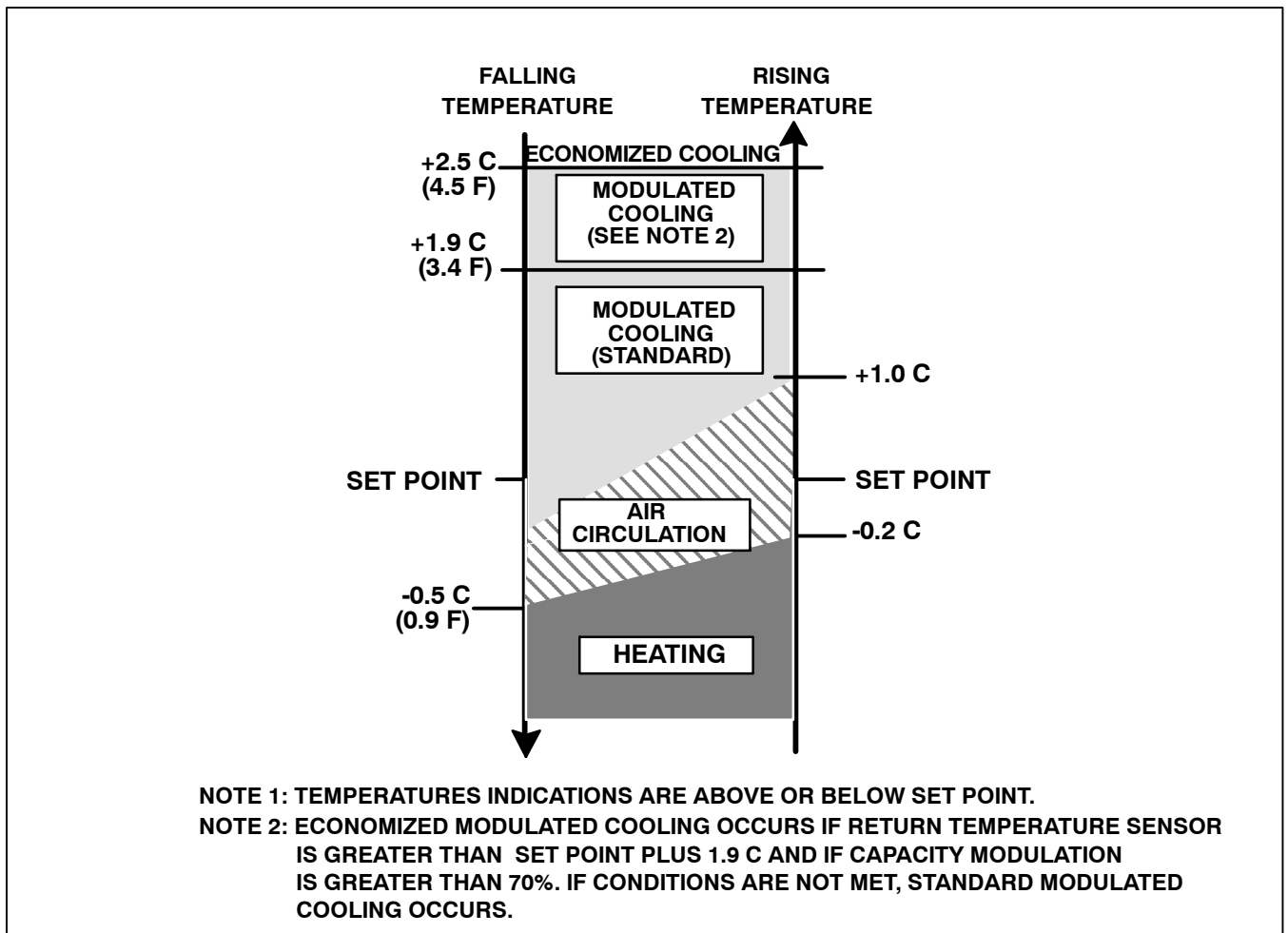

Figure 3-5 Controller Operation - Perishable Mode

3.3.7 Perishable Mode Cooling - Sequence of Operation

NOTE

In the Conventional Perishable Mode of Operation, the evaporator motors run in high speed. In the Economy Perishable Mode, the fan speed is varied.

- a. With supply air temperature above set point and decreasing, the unit will cool with the condenser fan motor (CF), compressor motor (CH), evaporator fan motors (EF) energized and the COOL light illuminated. (See Figure 3-6). Also, if current or pressure limiting is not active, the controller will close contacts TS to open the economizer solenoid valve (ESV) and place the unit in economized operation.
- b. When the air temperature decreases to a predetermined tolerance above set point, the in-range light is illuminated.

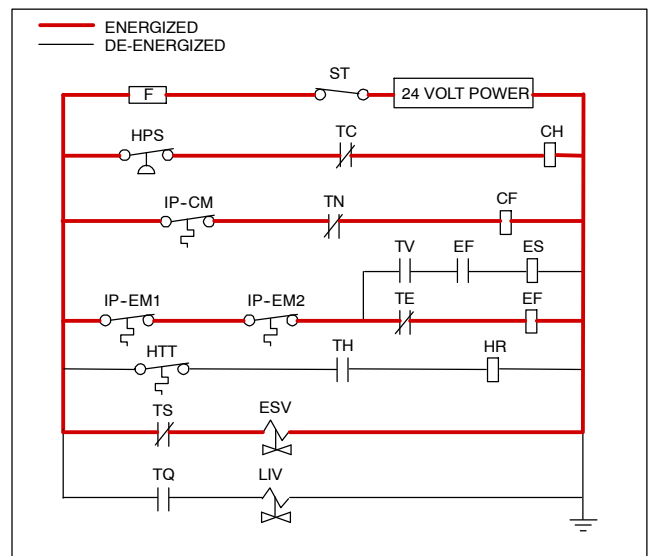

NOTE: The EEV and DUV are independently operated by the microprocessor. For full diagrams and legend, see Section 7.

Figure 3-6 Perishable Mode - Cooling

c. As the air temperature continues to fall, modulated cooling starts approximately 2.5C (4.5F) above set point. (See Figure 3-5). When modulated cool starts, the EEV control will transition from a full cool superheat set point to a lower modulated cool superheat set point. Once modulation starts, the EEV controls evaporator superheat based on the system duty cycle where instantaneous superheat will vary. When the return air has fallen to within 1.9C (3.4F) of set point temperature and the average capacity of the system has fallen below 70%, the unit will open contacts TS and close the ESV.

d. The controller monitors the supply air. Once the supply air falls below set point, the controller periodically records the supply air temperature, set point and time. A calculation is then performed to determine temperature drift from set point over time. If the calculation determines cooling is no longer required, contacts TC and TN are opened to de-energize compressor motor and condenser fan motor. In addition the controller will close the EEV. Perishable heat mode is locked disabled for five minutes. The cool light is also de-energized.

e. The evaporator fan motors continue to run to circulate air throughout the container. The in-range light remains illuminated as long as the supply air is within tolerance of set point.

f. If the return air temperature increases to 1.0C (1.8F) above set point and three minutes have elapsed, contacts TC and TN close to restart the compressor and condenser fan motors in standard mode (non-economized) operation. The cool light is also illuminated.

g. If the average system capacity has risen to 100% during modulated cooling and three minutes has elapsed, relay TS will energize and open the ESV, placing the unit in economized mode.

h. If the supply air increases more than 2.5C (4.5F) above set point temperature, the microprocessor will transition the evaporator superheat control from modulation back to full cool control.

3.3.8 Perishable Mode Heating - Sequence of Operation

a. If the air temperature decreases 0.5C (0.9F) below set point, the system enters the heating mode. (See Figure 3-5). The controller closes contacts TH (see Figure 3-7) to allow power flow through the heat termination thermostat (HTT) to energize the heaters (HR). The HEAT light is also illuminated. The evaporator fans continue to run to circulate air throughout the container.

b. When the temperature rises to 0.2C (0.4F) below set point, contacts TH open to de-energize the heaters. The HEAT light is also de-energized. The evaporator fans continue to run to circulate air throughout the container.

c. The safety heater termination thermostat (HTT) is attached to an evaporator coil circuit and will open the heating circuit if overheating occurs.

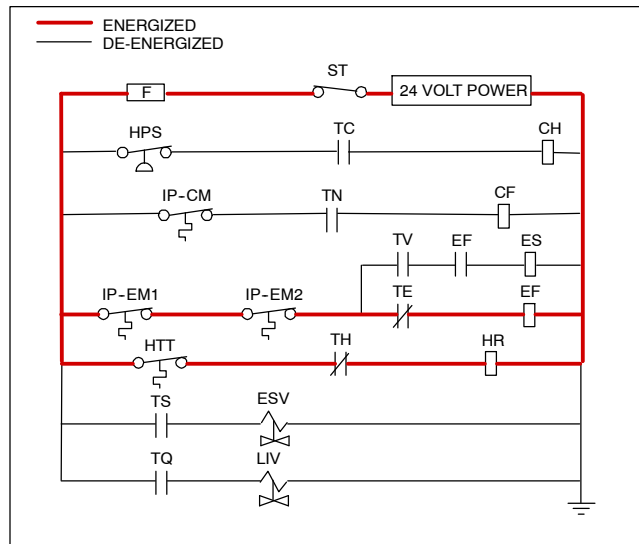

NOTE: The EEV and DUV are independently operated by the microprocessor. For full diagrams and legend, see Section 7.

Figure 3-7 Perishable Mode Heating

3.3.9 Sequence of Operation - Perishable Mode (Capacity Trim Heat)

a. If the system capacity has been decreased to the lowest allowable capacity and conditions exist that warrant maximum temperature stability the controller will pulse the HR relay to energize the evaporator heaters in sequence with the compressor digital signal. Trim heat is enabled only if (12.77C < set point < 15.55C [54.99F < set point < 59.99F]) and (-6.67C < ambient temperature < 1.66 C [19.99F < ambient temperature < 34.99F]).

3.3.10 Perishable Mode - Dehumidification

The dehumidification mode is provided to reduce the humidity levels inside the container. The mode is activated when a humidity value is set at function code Cd33. The display module SUPPLY LED will flash ON and OFF every second to indicate that the dehumidification mode is active. Once the Mode is active and the following conditions are satisfied, the controller will activate the heat relay to begin dehumidification.

1. The humidity sensor reading is above the set point.
2. The unit is in the perishable steady state mode and supply air temperature is less than 0.25C above set point.
3. The heater debounce timer (three minutes) has timed out.
4. Heater termination thermostat (HTT) is closed.

If the above conditions are true the evaporator fans will switch from high to low speed operation. The evaporator fan speed will switch every hour thereafter as long as all conditions are met (see Bulb Mode section for different evaporator fan speed options). If any condition except item (1) becomes false OR if the relative humidity sensed is 2% below the dehumidification set point, the high speed evaporator fans will be energized.

Power is applied to the defrost heaters in the dehumidification mode. This added heat load causes the controller to open the ESV to match the increased heat load while still holding the supply air temperature very close to the set point.

Opening the ESV reduces the temperature of the evaporator coil surface, which increases the rate at

which water is condensed from the passing air. Removing water from the air reduces the relative humidity. When the relative humidity sensed is 2% below the set point, the controller de-energizes the heat relay. The controller will continue to cycle heating to maintain relative humidity below the selected set point. If the mode is terminated by a condition other than the humidity sensor, e.g., an out-of-range or compressor shutdown condition, the heat relay is de-energized immediately.

Two timers are activated in the dehumidification mode to prevent rapid cycling and consequent contactor wear. They are:

1. Heater debounce timer (three minutes).
2. Out-of-range timer (five minutes).

The heater debounce timer is started whenever the heater contactor status is changed. The heat contactor remains energized (or de-energized) for at least three minutes even if the set point criteria are satisfied.

The out-of-range timer is started to maintain heater operation during a temporary out-of-range condition. If the supply air temperature remains outside of the user selected in-range setting for more than five minutes, the heaters will be de-energized to allow the system to recover. The out-of-range timer starts as soon as the temperature exceeds the in-range tolerance value set by function code Cd30.

3.3.11 Perishable, Dehumidification - Bulb Mode

Bulb mode is an extension of the dehumidification mode, which allows changes to the evaporator fan speed and/or defrost termination set points.

Bulb mode is active when configuration code Cd35 is set to "Bulb." Once the bulb mode is activated, the user may then change the dehumidification mode evaporator fan operation from the default (speed alternates from low to high each hour) to constant low or constant high speed. This is done by toggling function code Cd36 from its default of "alt" to "Lo" or "Hi" as desired. If low speed evaporator fan operation is selected, this gives the user the additional capability of selecting dehumidification set points from 60 to 95% (instead of the normal 65 to 95%).

In addition, if bulb mode is active, function code Cd37 may be set to override the previous defrost termination thermostat settings. (Refer to paragraph NO TAG) The temperature at which the defrost termination thermostat will be considered "open" may be changed [in 0.1C (0.2F) increments] to any value between 25.6C (78F) and 4C (39.2F). The temperature at which the defrost termination thermostat is considered closed for interval timer start or demand defrost is 10C for "open" values from 25.6C (78F) down to a 10C setting. For "open" values lower than 10C, the "closed" values will decrease to the same value as the "open" setting. Bulb mode is terminated when:

1. Bulb mode code Cd35 is set to "Nor."
2. Dehumidification code Cd33 is set to "Off."
3. The user changes the set point to one that is in the frozen range.

When bulb mode is disabled by any of the above, the evaporator fan operation for dehumidification reverts to "alt" and the DTS termination setting resets to the value determined by controller configuration variable CnF41.

3.3.12 Frozen - Pulldown

Schematic representation of controller action is provided in Figure 3-8. When cooling from a temperature that is more than 2.5C (4.5F) above set point, the system will be in the frozen pulldown mode. It will transition to economized operation. However, pressure and current limit functions may restrict the valve, if either exceeds the preset value.

3.3.13 Frozen Mode Temperature Control

When in the frozen mode, the controller maintains the return air temperature at set point, the RETURN indicator light will be illuminated on the display module and the default reading on the display window will be the return air probe reading.

When the return air temperature enters the in-range temperature tolerance as selected at function code Cd30, the in-range light will energize.

3.3.14 Frozen Mode - Conventional

Frozen range cargos are not sensitive to minor temperature changes. The method of temperature control employed in this range takes advantage of this to greatly improve the energy efficiency of the unit. Temperature control in the frozen range is accomplished by cycling the compressor on and off as the load demand requires.

Once set point is reached, the unit will transition to the frozen steady state mode (economized operation).

When temperature drops to set point minus 0.2C and the compressor has run for at least five minutes, the unit will transition to the frozen idle mode. The compressor is turned off and the evaporator fans continue to run to circulate air throughout the container. If temperature rises above set point +0.2C, the unit will transition back to the frozen steady state mode.

3.3.15 Frozen Mode - Heat Lockout Temperature

With configuration variable CnF26 (Heat Lockout Temperature) set to -10C the frozen mode of operation is active with set points *at or below* -10C (+14F). With the variable set to -5C, the frozen mode is active *at or below* -5C (+23F).

If the temperature drops 10C below set point, the unit will transition to the frozen "heating" mode, in which the evaporator fans are brought to high speed. The unit will transition back to the frozen steady state mode when the temperature rises back to the transition point.

3.3.16 Frozen Mode - Economy

In order to activate economy frozen mode operation, a frozen set point temperature must be selected. The economy mode is active when function code Cd34 is set to "ON." When economy mode frozen is active, the system will perform normal frozen mode operations except that the entire refrigeration system, excluding the controller, will be turned off when the control temperature is less than or equal to the set point -2C. After an off-cycle period of 60 minutes, the unit will turn on high speed evaporator fans for three minutes, and then check the control temperature. If the control temperature is greater than or equal to the set point +0.2C, the unit will restart the refrigeration system and continue to cool until the previously mentioned off-cycle temperature criteria are met. If the control temperature is less than the set point +0.2C, the unit will turn off the evaporator fans and restart another 60 minute off-cycle.

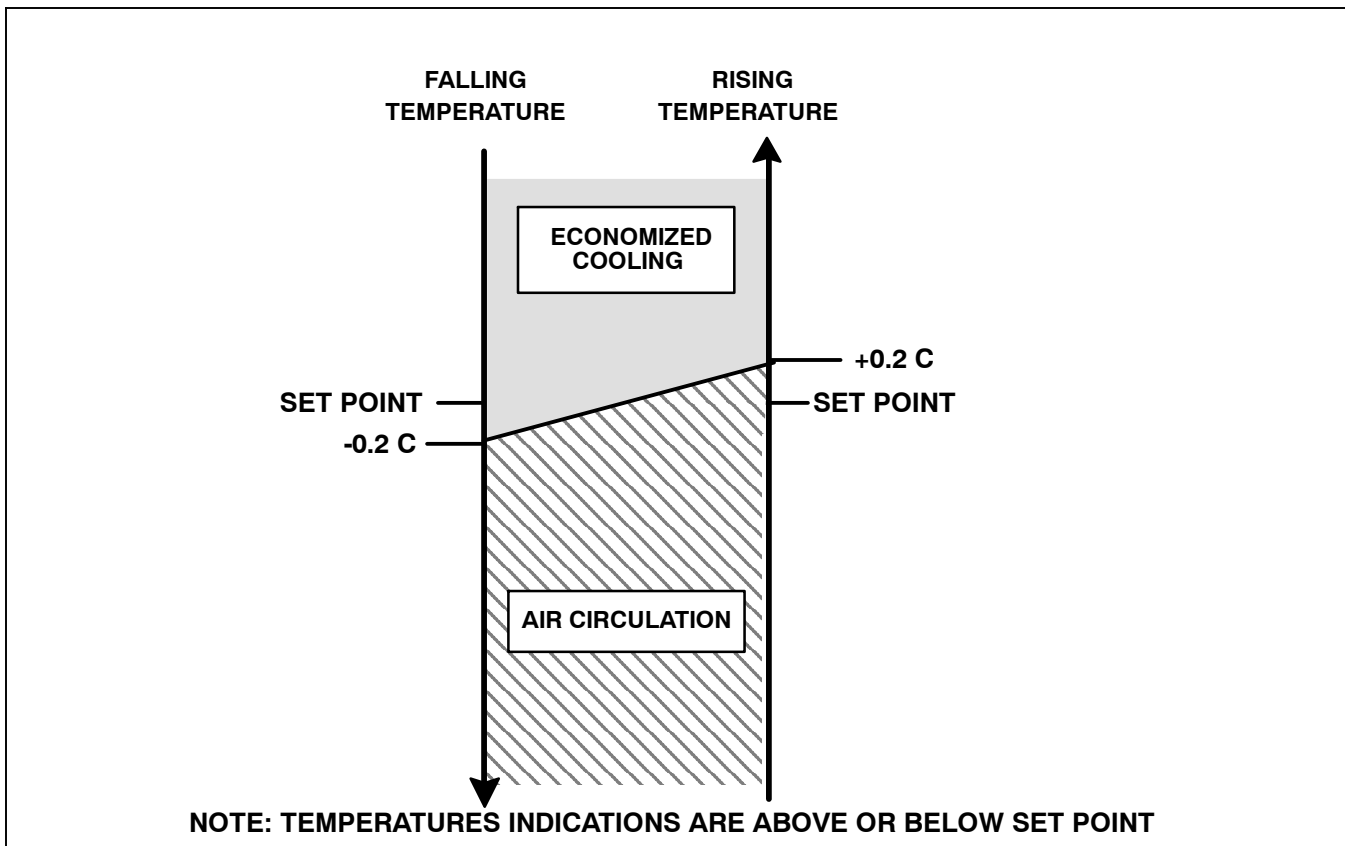
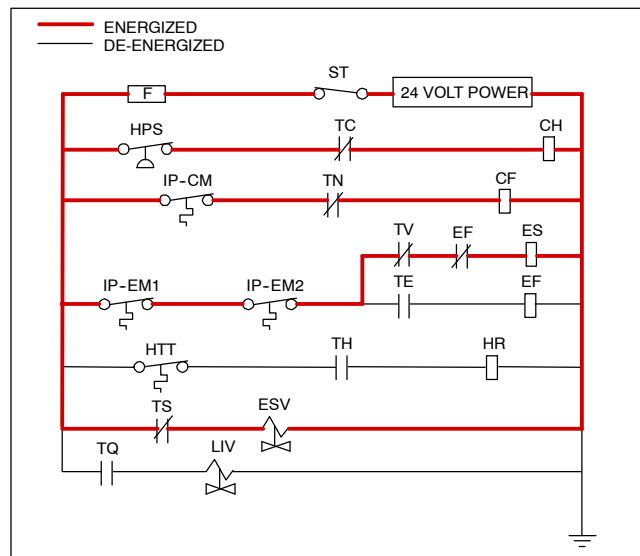

Figure 3-8 Controller Operation - Frozen Mode

3.3.17 Frozen Mode Cooling - Sequence of Operation

- When the supply air temperature is above set point and decreasing, the unit will transition to economized cooling with the condenser fan motor (CF), compressor motor (CH), economizer solenoid valve (ESV), low speed evaporator fan motors (ES) energized and the COOL light illuminated. (See Figure 3-9).
- When the air temperature decreases to a predetermined tolerance above set point, the in-range light is illuminated.
- When the return air temperature decreases to 0.2C (0.4F) below set point, contacts TC, TS and TN are opened to de-energize the compressor, economizer solenoid valve and condenser fan motor. The cool light is also de-energized. The EEV will close.
- The evaporator fan motors continue to run in low speed to circulate air throughout the container. The in-range light remains illuminated as long as the return air is within tolerance of set point.
- If return air temperature drops to 10C (18F) or more below set point, the evaporator fans increase to high speed.
- When the return air temperature increases to 0.2C (0.4F) above set point and three minutes have elapsed, the EEV opens and contacts TC, TS and TN close to restart the compressor, open the ESV and restart the condenser fan motor. The cool light is illuminated.



NOTE: The EEV and DUV are independently operated by the microprocessor. For full diagrams and legend, see Section 7.

Figure 3-9 Frozen Mode

3.3.18 Defrost Interval

Controller function code Cd27 sets two modes for defrost initiation, either user-selected timed intervals or automatic control. The user-selected values are 3, 6, 9, 12, 24 hours or AUTO. Some units may be configured to allow defrost to be disabled altogether. In this case, a user-selected value of OFF will be available. The factory default for defrost is AUTO. Refer to Table 3-5.

In perishable mode, perishable-pulldown mode, or frozen-pulldown mode, automatic defrost starts with an initial defrost set to three hours and then adjusts the interval to the next defrost based on the accumulation of ice on the evaporator coil. In this way, defrosts are scheduled to occur only when necessary.

Once set point has been reached in frozen operation, the automatic selection will set the time interval to 12 hours for the first two defrosts once the return probe is reading below the frozen set point and then adjust to 24 hours thereafter.

All defrost interval times reflect the number of compressor runtime hours since the last defrost de-ice cycle. The minimum defrost interval under the automatic setting is three hours while the maximum is 24. In frozen mode the amount of wall-clock time necessary to accumulate a given amount of defrost interval time will exceed the defrost interval time by a factor of two to three depending on the compressor duty-cycle. Defrost interval time is not accumulated in any mode until the defrost termination sensor reads less than 10C (50F).

If defrost does not terminate correctly and temperature reaches set point of the heat termination thermostat (HTT), the thermostat will open to de-energize the heaters. If termination does not occur within two hours, the controller will terminate defrost. An alarm will be activated to inform of a possible DTS failure.

If probe check (controller function code CnF31) is configured to SPECIAL, the unit will proceed to the next operation (snap freeze or terminate defrost). If the code is configured to STANDARD, the unit will perform a probe check. The purpose of the probe check is to detect malfunctions in the sensed temperature. If probe check fails, the system will run for eight minutes to validate. At the end of eight minutes, probe alarms will be set or cleared based on the conditions seen.

When the return air falls to 7C (45F), the controller ensures that the defrost temperature sensor (DTS) reading has dropped to 10C or below. If it has not, a DTS failure alarm is given and the defrost mode is operated by the return temperature sensor (RTS).

If controller function code CnF33 is configured to snap freeze, the controller will sequence to this operation. The snap freeze consists of running the compressor without the evaporator fans in operation for a period of 4 minutes at 100% capacity. When the snap freeze is completed, defrost is formally terminated.

3.3.19 Defrost Mode - Sequence of Operation

- a. The defrost cycle may consist of up to three distinct operations. The first is de-icing of the coil, the second is a probe check cycle and the third is snap freeze. Defrost may be initiated by any one of the following methods:
 1. The manual defrost function (also manual defrost switch function, if equipped) is initiated by the user

through the use of the keypad or manual defrost switch. The manual defrost function is ended by use of the DTS.

NOTE

The Manual Defrost / Interval key can be used to initiate a manual defrost.

Manual Defrost/Interval key operation:

Depressing and holding the Defrost Interval key for five seconds will initiate defrost. If the defrost interval key is released in less than five seconds, defrost interval (code 27) shall be displayed.

2. The user sends a defrost command by communications.
3. The defrost interval timer (controller function code Cd27) reaches the defrost interval set by the user.
4. The controller probe diagnostic logic determines that a probe check is necessary based on the temperature values currently reported by the supply and return probes.
5. If the controller is programmed with the Demand Defrost option and the option is set to "IN" the unit will enter defrost if it has been in operation for more than 2.5 hours without reaching set point.
6. The system is actively in a compressor suction pressure or high pressure ratio protection mode and reduced the average system capacity below a predetermined threshold value.

Defrost may be initiated any time the defrost temperature sensor reading falls below the controller defrost termination thermostat set point. Defrost will terminate when the defrost temperature sensor reading rises above the defrost termination thermostat set point. The defrost termination thermostat is not a physical component. It is a controller setting that acts as a thermostat, "closing" (allowing defrost) when the defrost temperature sensor reading is below the set point and "opening" (terminating or preventing defrost) when the sensor temperature reading is above set point. When the unit is operating in bulb mode (refer to paragraph NO TAG), special settings may be applicable.

If the controller is programmed with the Lower DTT setting option, the defrost termination thermostat set point may be configured to the default of 25.6C (78F) or lowered to 18C (64F). When a request for defrost is made through the manual defrost switch, communications or probe check the unit will enter defrost if the defrost temperature thermostat reading is at or below the defrost termination thermostat setting. Defrost will terminate when the defrost temperature sensor reading rises above the defrost termination thermostat setting. When a request for defrost is made with the defrost interval timer or by demand defrost, the defrost temperature setting must be below 10C (50F).

When the defrost mode is initiated, the controller closes the EEV, opens contacts TC, TN and TE (or TV) to de-energize the compressor, condenser fan and evaporator fans. The COOL light is also de-energized. The controller then closes contacts TH to supply power to the heaters. The defrost light is illuminated. When the defrost temperature sensor reading rises to the defrost termination thermostat setting, the de-icing operation is terminated.

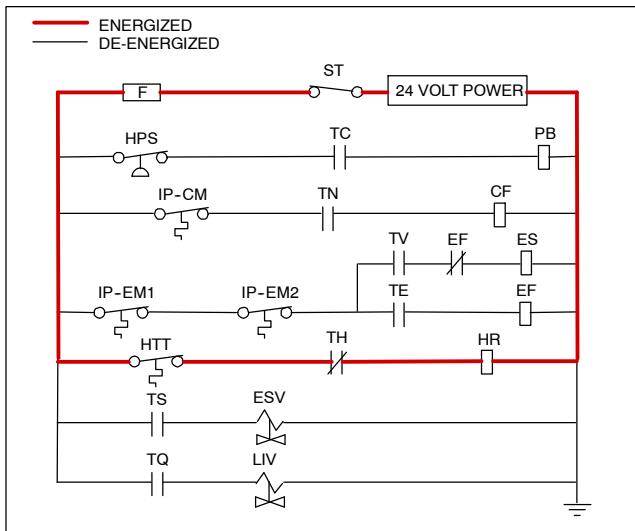

NOTE: The EEV and DUV are independently operated by the microprocessor. For full diagrams and legend, see Section 7.

Figure 3-10 Defrost

3.4 PROTECTION MODES OF OPERATION

3.4.1 Evaporator Fan Operation

Opening of an evaporator fan internal protector will shut down the unit.

3.4.2 Failure Action

Function code Cd29 may be operator set to select action the controller will take upon system failure. The factory default is full system shutdown. Refer to Table 3-5.

3.4.3 Generator Protection

Function codes Cd31 (Stagger Start, Offset Time) and Cd32 (Current Limit) may be operator set to control start up sequence of multiple units and operating current draw. The factory default allows on demand starting (no delay) of units and normal current draw. Refer to Table 3-5.

3.4.4 Compressor High Temperature, Low Pressure Protection

The controller monitors compressor discharge pressure, and temperature and suction pressure. If discharge pressure or temperature rises above the allowed limit or suction pressure falls below the allowed limit, the compressor will be cycled off on a three-minute timer. Condenser and evaporator fans continue to operate during the compressor off cycle.

1. If compressor dome temperature exceeds 136C (276.8F) continuously for five seconds (high dome temperature), the liquid injection solenoid valve will open. When compressor dome temperature then decreases to 121C (249.8F) or below, the liquid injection solenoid valve will close.
2. If suction superheat exceeds a 55C range during unloaded capacity mode operation (suction quench), the liquid injection solenoid valve will open. When suction superheat decreases below 20C range, or if unit leaves unloaded capacity mode, the liquid injection solenoid valve will close.

3. If conditions occur that would require the liquid injection valve to open, valve will close when dome temperature goes below 136C and suction superheat is less than 20C range.

3.4.5 Perishable Mode - System Pressure Regulation

In perishable mode, system pressures may need to be regulated at ambient temperatures of 20C (68F) and below. Once below this ambient temperature, the condenser fan may cycle on and off based on limits imposed for discharge pressure. For extremely cold ambient temperatures, -18C (0F), heater cycling may occur within normal system operation based on discharge pressure limits.

3.4.6 Condenser Fan Switch Override

When configuration variable CnF15 (Discharge Temperature Sensor) is set to "In" and CnF48 (Condenser Fan Switch Override) is set to "On" the condenser fan switch override logic is activated. If condenser cooling water pressure is sufficient to open the water pressure switch (de-energizing the condenser fan) when water flow or temperature conditions are not maintaining discharge temperature, the logic will energize the condenser fan as follows:

1. If the discharge temperature switch reading is valid and discharge temperature is greater than 115C (240F), the condenser fan is energized.
2. When discharge temperature falls to 90.5C (195F), the condenser fan is de-energized.
3. If the system is running on condenser fan override and the high pressure switch opens twice within a seven-minute period, the condenser fan is energized and will remain energized until the system is power cycled. Alarm 58 (Compressor High Pressure Safety) will be triggered.

3.5 CONTROLLER ALARMS

Alarm display is an independent controller software function. If an operating parameter is outside of expected range or a component does not return the correct signals back to the controller, an alarm is generated. A listing of the alarms is provided in Table 3-6, page 3-23.

The alarm philosophy balances the protection of the refrigeration unit and that of the refrigerated cargo. The action taken when an error is detected always considers the survival of the cargo. Rechecks are made to confirm that an error actually exists.

Some alarms requiring compressor shutdown have time delays before and after to try to keep the compressor on line. An example is alarm code "LO," (low main voltage), when a voltage drop of over 25% occurs, an indication is given on the display, but the unit will continue to run.

When an Alarm Occurs:

- a. The red alarm light will illuminate for alarm code numbers 15, 17, 20, 21, 22, 23, 24, 25, 26, and 27.
- b. If a detectable problem exists, its alarm code will be alternately displayed with the set point on the left display.
- c. The user should scroll through the alarm list to determine what alarms exist or have existed. Alarms must be diagnosed and corrected before Alarm List can be cleared.

To Display Alarm Codes:

- a. While in the Default Display mode, press the ALARM LIST key. This accesses the Alarm List Display Mode, which displays any alarms archived in the alarm queue.
- b. The alarm queue stores up to 16 alarms in the sequence in which they occurred. The user may scroll through the list by depressing an ARROW key.
- c. The left display will show "AL##," where ## is the alarm number sequentially in the queue.
- d. The right display will show the actual alarm code. "AA##" will display for an active alarm, where "##" is the alarm code. Or "IA##" will display for an inactive alarm, See Table 3-6, page 3-23.
- e. "END" is displayed to indicate the end of the alarm list if any alarms are active.
- f. "CLEAR" is displayed if all alarms are inactive. The alarm queue may then be cleared by pressing the ENTER key. The alarm list will clear and "----" will be displayed.

Note:

AL26 is active when all of the sensors are not responding. Check the connector at the back of the controller; if it is loose or unplugged, reconnect it, then run a pre-trip test (P5) to clear AL26.

3.6 UNIT PRE-TRIP DIAGNOSTICS

Pre-Trip Diagnostics is an independent controller function that suspends normal refrigeration controller activities and provide preprogrammed test routines. The test routines include Auto Mode testing, which automatically performs a pre programmed sequenced of tests, or Manual Mode testing, which allows the operator to select and run any of the individual tests.



Pre-trip inspection should not be performed with critical temperature cargoes in the container.



When Pre-Trip key is pressed, economy, dehumidification and bulb mode will be deactivated. At the completion of Pre-Trip activity, economy, dehumidification and bulb mode must be reactivated.

Testing may be initiated by use of the keypad or via communication, but when initiated by communication the controller will execute the entire battery of tests (auto mode).

At the end of a pre-trip test, the message "P," "rSLts" (pretest results) will be displayed. Pressing the ENTER key will allow the user to see the results for all subtests. The results will be displayed as "PASS" or "FAIL" for all the tests run to completion.

A detailed description of the pre-trip tests and test codes is provided in Table 3-7, page 3-27. detailed operating instructions are provided in paragraph 4.8.

3.7 DataCORDER

3.7.1 Description

The Carrier Transicold "DataCORDER" software is integrated into the controller and serves to eliminate the temperature recorder and paper chart. The DataCORDER functions may be accessed by keypad selections and viewed on the display module. The unit is also fitted with interrogation connections (see Figure 3-1) which may be used with the Carrier Transicold Data Reader to download data. A personal computer with Carrier Transicold DataLINE software may also be used to download data and configure settings. The DataCORDER consists of:

- Configuration Software
- Operational Software
- Data Storage Memory
- Real Time Clock (with internal battery backup)
- Six Thermistor Inputs
- Interrogation Connections
- Power Supply (battery pack)

The DataCORDER performs the following functions:

- a. Logs data at 15, 30, 60 or 120 minute intervals and stores two years of data (based on one hour interval).
- b. Records and displays alarms on the display module.
- c. Records results of pre-trip testing.
- d. Records DataCORDER and temperature control software generated data and events as follows:
 - Container ID Change
 - Software Upgrades
 - Alarm Activity
 - Battery Low (battery pack)
 - Data Retrieval
 - Defrost Start and End
 - Dehumidification Start and End
 - Power Loss (with and without battery pack)
 - Power Up (with and without battery pack)
 - Remote Probe Temperatures in the Container (USDA Cold treatment and Cargo probe recording)
 - Return Air Temperature
 - Set Point Change
 - Supply Air Temperature
 - Real Time Clock Battery (internal battery) Replacement
 - Real Time Clock Modification
 - Trip Start
 - ISO Trip Header (When entered via Interrogation program)
 - Economy Mode Start and End
 - "Auto 1/Auto 2/Auto 3" Pre-Trip Start and End
 - Bulb Mode Start
 - Bulb Mode Changes
 - Bulb Mode End
 - USDA Trip Comment
 - Humidification Start and End
 - USDA Probe Calibration
 - Fresh Air Vent Position

3.7.2 DataCORDER Software

The DataCORDER Software is subdivided into the Operational Software, Configuration Software, and the Data Memory.

a. Operational Software

The Operational Software reads and interprets inputs for use by the Configuration Software. The inputs are labeled Function Codes. Controller functions (see Table 3-8, page 3-31) which the operator may access to examine the current input data or stored data. To access these codes, do the following:

1. Press the ALT. MODE and CODE SELECT keys.
2. Press an arrow key until the left window displays the desired code number. The right window will display the value of this item for five seconds before returning to the normal display mode.
3. If a longer display time is desired, press the ENTER key to extend the display time to five minutes.

b. Configuration Software

The configuration software controls the recording and alarm functions of the DataCORDER. Reprogramming to the factory-installed configuration is achieved via a configuration card. Changes to the unit DataCORDER configuration may be made using the DataView/DataLINE interrogation software. A listing of the configuration variables is provided in Table 3-2. Descriptions of DataCORDER operation for each variable setting are provided in the following paragraphs.

3.7.3 Sensor Configuration (dCF02)

Two modes of operation may be configured, the Standard Mode and the Generic Mode.

a. Standard Mode

In the standard mode, the user may configure the DataCORDER to record data using one of seven standard configurations. The seven standard configuration variables, with their descriptions, are listed in Table 3-3.

The inputs of the six thermistors (supply, return, USDA #1, #2, #3 and cargo probe) and the humidity sensor input will be generated by the DataCORDER. See Figure 3-11.

NOTE

The DataCORDER software uses the supply and return recorder sensors (SRS, RRS). The temperature control software uses the supply and return temperature sensors (STS, RTS) .

b. Generic Mode

The generic recording mode allows user selection of the network data points to be recorded. The user may select up to a total of eight data points for recording. A list of the data points available for recording follows. Changing the configuration to generic and selecting which data points to record may be done using the Carrier Transicold Data Retrieval Program.

1. Control mode
2. Control temperature
3. Frequency
4. Humidity
5. Phase A current
6. Phase B current
7. Phase C current
8. Main voltage
9. Evaporator expansion valve percentage
10. Discrete outputs (Bit mapped - require special handling if used)
11. Discrete inputs (Bit mapped - require special handling if used)
12. Ambient sensor
13. Evaporator temperature sensor
14. Compressor discharge sensor
15. Return temperature sensor (RTS)
16. Supply temperature sensor (STS)
17. Defrost temperature sensor
18. Discharge pressure transducer
19. Suction pressure transducer
20. Condenser pressure transducer
21. Vent position sensor (VPS)

3.7.4 Logging Interval (dCF03)

The user may select four different time intervals between data recordings. Data is logged at exact intervals in accordance with the real time clock. The clock is factory set at Greenwich Mean Time (GMT).

3.7.5 Thermistor Format (dCF04)

The user may configure the format in which the thermistor readings are recorded. The short resolution is a 1 byte format and the long resolution is a 2 byte format. The short requires less memory and records temperature with variable resolutions depending on temperature range. The long records temperature in 0.01C (0.02F) steps for the entire range.

Table 3-2 DataCORDER Configuration Variables

CONFIGURATION NO.	TITLE	DEFAULT	OPTION
dCF01	(Future Use)	--	--
dCF02	Sensor Configuration	2	2,5,6,9,54,64,94
dCF03	Logging Interval (Minutes)	60	15,30,60,120
dCF04	Thermistor Format	Short	Long
dCF05	Thermistor Sampling Type	A	A,b,C
dCF06	Controlled Atmosphere/Humidity Sampling Type	A	A,b
dCF07	Alarm Configuration USDA Sensor 1	A	Auto, On, Off
dCF08	Alarm Configuration USDA Sensor 2	A	Auto, On, Off
dCF09	Alarm Configuration USDA Sensor 3	A	Auto, On, Off
dCF10	Alarm Configuration Cargo Sensor	A	Auto, On, Off

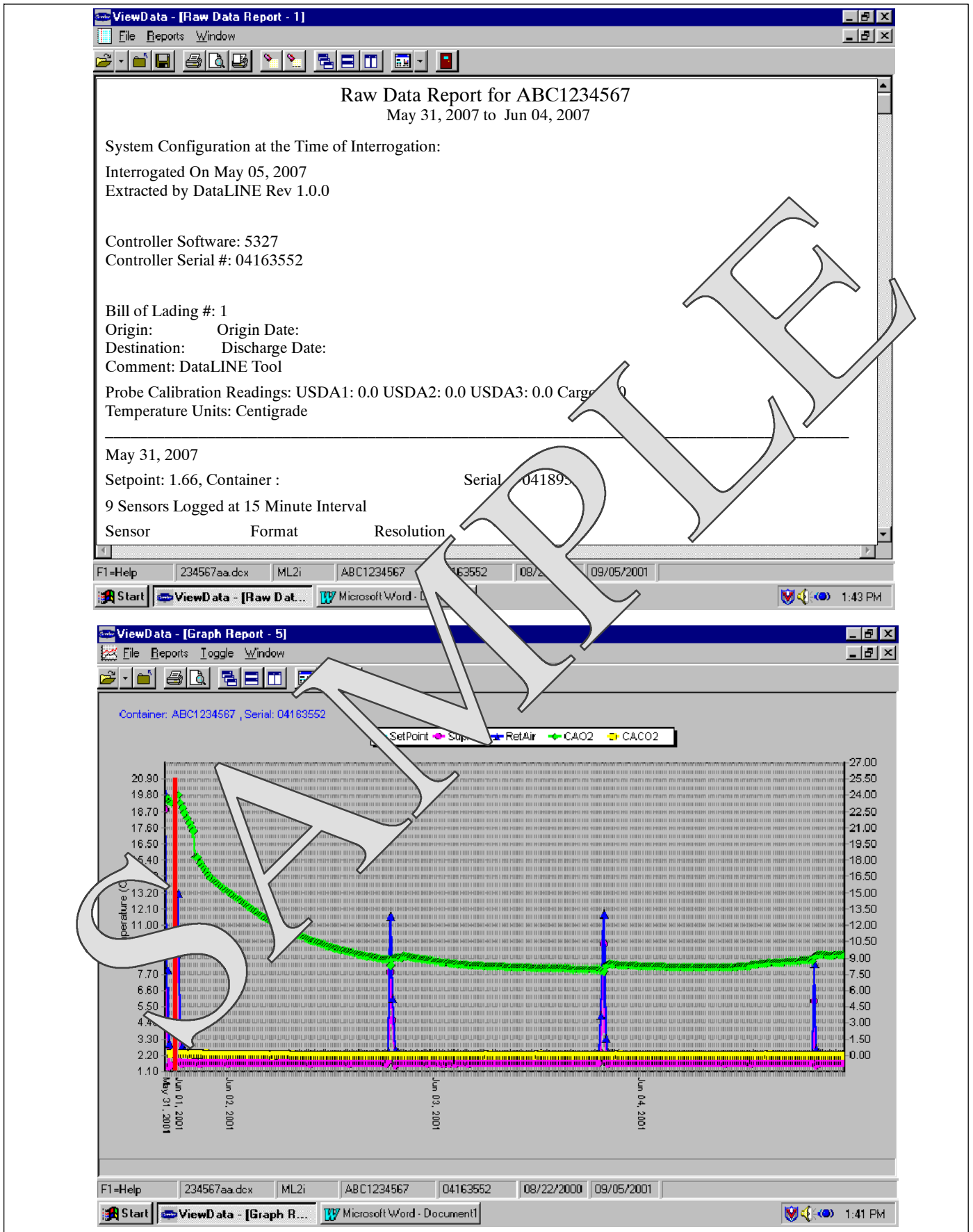

Figure 3-11 Standard Configuration Download Report

Table 3-3 DataCORDER Standard Configurations

Standard Config.	Description
2 sensors (dCF02=2)	2 thermistor inputs (supply & return)
5 sensors (dCF02=5)	2 thermistor inputs (supply & return) 3 USDA thermistor inputs
6 sensors (dCF02=6)	2 thermistor inputs (supply & return) 3 USDA thermistor inputs 1 humidity input
9 sensors (dCF02=9)	Not Applicable
6 sensors (dCF02=54)	2 thermistor inputs (supply & return) 3 USDA thermistor inputs 1 cargo probe (thermistor input)
7 sensors (dCF02=64)	2 thermistor inputs (supply & return) 3 USDA thermistor inputs 1 humidity input 1 cargo probe (thermistor input)
10 sensors (dCF02=94)	2 thermistor inputs (supply & return) 3 USDA thermistor inputs 1 humidity input 1 cargo probe (thermistor input) 3 C.A. inputs (NOT APPLICABLE)

3.7.6 Sampling Type (dCF05 & dCF06)

Three types of data sampling are available: average snapshot and USDA. When configured to average, the average of readings taken every minute over the recording period is recorded. When configured to snapshot, the sensor reading at the log interval time is recorded. When USDA is configured, the supply and return temperature readings are averaged and the three USDA probe readings are snapshot.

3.7.7 Alarm Configuration (dCF07 - dCF10)

The USDA and cargo probe alarms may be configured to OFF, ON or AUTO.

If a probe alarm is configured to OFF, the alarm for this probe is always disabled.

If a probe alarm is configured to ON, the associated alarm is always enabled.

If the probes are configured to AUTO, they act as a group. This function is designed to assist users who keep their DataCORDER configured for USDA recording, but do not install the probes for every trip. If all the probes are disconnected, no alarms are activated. As soon as one of the probes is installed, all of the alarms are enabled and the remaining probes that are not installed will give active alarm indications.

3.7.8 DataCORDER Power-Up

The DataCORDER may be powered up in any one of four ways:

1. *Normal AC power:* The DataCORDER is powered up when the unit is turned on via the stop-start switch.
2. *Controller DC battery pack power:* If a battery pack is installed, the DataCORDER will power up for

communication when an interrogation cable is plugged into an interrogation receptacle.

3. *External DC battery pack power:* A 12 volt battery pack may also be plugged into the back of the interrogation cable, which is then plugged into an interrogation port. No controller battery pack is required with this method.

4. *Real Time Clock demand:* If the DataCORDER is equipped with a charged battery pack and AC power is not present, the DataCORDER will power up when the real time clock indicates that a data recording should take place. When the DataCORDER is finished recording, it will power down.

During DataCORDER power-up, while using battery-pack power, the controller will perform a hardware voltage check on the battery. If the hardware check passes, the controller will energize and perform a software battery voltage check before DataCORDER logging. If either test fails, the real time clock battery power-up will be disabled until the next AC power cycle. Further DataCORDER temperature logging will be prohibited until that time.

An alarm will be generated when the battery voltage transitions from good to bad indicating that the battery pack needs recharging. If the alarm condition persists for more than 24 hours on continuous AC power, the battery pack needs replacement.

3.7.9 Pre-Trip Data Recording

The DataCORDER will record the initiation of a pre-trip test (refer to paragraph 3.6) and the results of each of the tests included in pre-trip. The data is time-stamped and may be extracted via the Data Retrieval program. Refer to Table 3-9 for a description of the data stored in the DataCORDER for each corresponding Pre-Trip test.

3.7.10 DataCORDER Communications

Data retrieval from the DataCORDER can be accomplished by using one of the following: DataReader, DataLINE/DataView or a communications interface module.

NOTE

A DataReader, DataLINE/DataView or a communications interface module display of Communication Failed is caused by faulty data transfer between the DataCORDER and the data retrieval device. Common causes include:

1. Bad cable or connection between DataCORDER and data retrieval device.
2. PC communication port(s) unavailable or misassigned.
3. Chart Recorder Fuse (FCR) blown.

Configuration identification for the models covered herein may be obtained on the Container Products Group Information Center by authorized Carrier Transicold Service Centers.

a. DataReader

The Carrier Transicold Data Reader (see Figure 3-12) is a simple to operate handheld device designed to extract data from the DataCORDER and upload it to a PC. The Data Reader has the ability to store multiple data files. Refer to Data Retrieval manual 62-02575 for a more detailed explanation of the DataReader.

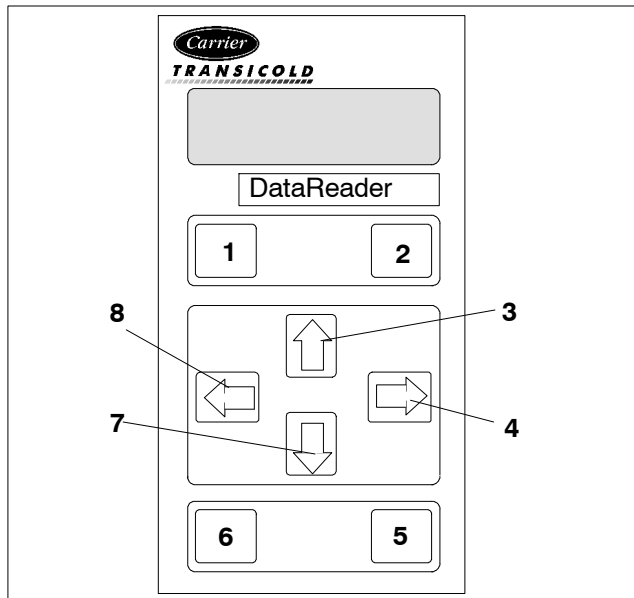

- | | |
|----------------|---------------|
| 1. OFF | 5. ENTER |
| 2. ON | 6. Escape |
| 3. UP Arrow | 7. DOWN Arrow |
| 4. RIGHT Arrow | 8. LEFT Arrow |

Figure 3-12 Data Reader

b. DataBANK™ Card

The DataBANK™ card is a PCMCIA card that interfaces with the controller through the programming slot and can download the data at a much faster rate, when compared to the PC or DataReader. Files downloaded to DataBANK card files are accessible through an Omni PC Card Drive. The files can then be viewed using the DataLINE software.

c. DataLINE

The DataLINE software for a personal computer is supplied on both floppy disks and CD. This software allows interrogation, configuration variable assignment, screen view of the data, hard copy report generation, cold treatment probe calibration and file management. Refer to Data Retrieval manual 62-10629 for a more detailed explanation of the DataLINE interrogation software. The DataLINE manual may be found on the internet at www.container.carrier.com.

d. Communications Interface Module

The communications interface module is a slave module, which allows communication with a master central monitoring station. The module will respond to communication and return information over the main power line.

With a communications interface module installed, all functions and selectable features that are accessible at the unit may be performed at the master station. Retrieval of all DataCORDER reports may also be performed. Refer to the master system technical manual for further information.

3.7.11 USDA Cold Treatment

Sustained cold temperature has been employed as an effective postharvest method for the control of Mediterranean and certain other tropical fruit flies. Exposing infested fruit to temperatures of 2.2C (36F) or below for specific periods results in the mortality of the various stages of this group of insects.

In response to the demand to replace fumigation with this environmentally sound process, Carrier has integrated Cold Treatment capability into its microprocessor system. These units have the ability to maintain supply air temperature within one-quarter degree Celsius of set point and record minute changes in product temperature within the DataCORDER memory, thus meeting USDA criteria. Information on USDA is provided in the following subparagraphs

a. USDA Recording

A special type of recording is used for USDA cold treatment purposes. Cold treatment recording requires three remote temperature probes be placed at prescribed locations in the cargo. Provision is made to connect these probes to the DataCORDER via receptacles located at the rear left-hand side of the unit. Four or five receptacles are provided. The four 3-pin receptacles are for the probes. The 5-pin receptacle is the rear connection for the Interrogator. The probe receptacles are sized to accept plugs with tricam coupling locking devices. A label on the back panel of the unit shows which receptacle is used for each probe.

The standard DataCORDER report displays the supply and return air temperatures. The cold treatment report displays USDA #1, #2, #3 and the supply and return air temperatures. Cold treatment recording is backed up by a battery so recording can continue if AC power is lost.

b. USDA/ Message Trip Comment

A special feature, incorporated in DataLINE/DataView, allows the user to enter a USDA (or other) message in the header of a data report. The maximum message length is 78 characters. Only one message will be recorded per day.

3.7.12 USDA Cold Treatment Procedure

The following is a summary of the steps required to initiate a USDA Cold Treatment:

- a. Calibrate the three USDA probes by ice bathing the probes and performing the calibration function with the DataReader, DataView or DataLINE. This calibration procedure determines the probe offsets and stores them in the controller for use in generating the cold treatment report. Refer to the Data Retrieval manual 62-02575 for more details.
- b. Pre-cool the container to the treatment temperature or below.
- c. Install the DataCORDER module battery pack (if not already installed).
- d. Place the three probes. The probes are placed into the pulp of the product (at the locations defined in the following table) as the product is loaded.

Sensor 1	Place in pulp of the product located next to the return air intake.
Sensor 2	Place in pulp of the product five feet from the end of the load for 40 foot containers, or three feet from the end of the load for 20 foot containers. This probe should be placed in a center carton at one-half the height of the load.
Sensor 3	Place in pulp of product five feet from the end of the load for 40 foot containers or three feet from the end of the load for 20 foot containers. This probe should be placed in a carton at a side wall at one-half the height of the load.

e. To initiate USDA recording, connect the personal computer and perform the configuration as follows, using either the DataView or DataLINE software:

1. Enter ISO header information.
2. Enter a trip comment if desired.
3. Configure the DataCORDER for five probes (s, r, P1, P2, P3) (dcf02=5).
4. Configure the logging interval for one hour.
5. Set the sensor configuration to "USDA."
6. Configure for two byte memory storage format (dcf04=LONG).
7. Perform a "trip start."

3.7.13 DataCORDER Alarms

The alarm display is an independent DataCORDER function. If an operating parameter is outside of the expected range or a component does not return the correct values to the DataCORDER, an alarm is generated. The DataCORDER contains a buffer of up to eight alarms. A listing of the DataCORDER alarms is provided in Table 3-10, page 3-33. Refer to paragraph 3.7.7 for configuration information.

To display alarm codes:

- a. While in the Default Display mode, press the ALT. MODE & ALARM LIST keys. This accesses the DataCORDER Alarm List Display Mode, which displays any alarms stored in the alarm queue.
- b. To scroll to the end of the alarm list, press the UP ARROW. Depressing the DOWN ARROW key will scroll the list backward.
- c. The left display will show "AL#" where # is the alarms number in the queue. The right display will show "AA##," if the alarm is active, where ## is the alarm number. "IA##," will show if the alarm is inactive
- d. "END" is displayed to indicate the end of the alarm list if any alarms are active. "CLEAR" is displayed if all the alarms in the list are inactive.

e. If no alarms are active, the alarm queue may be cleared. The exception to this rule is the DataCORDER alarm queue Full alarm (AL91), which does not have to be inactive in order to clear the alarm list. To clear the alarm list:

1. Press the ALT. MODE & ALARM LIST keys.
2. Press the UP/DOWN ARROW key until "CLEAR" is displayed.
3. Press the ENTER key. The alarm list will clear and "----" will be displayed.
4. Press the ALARM LIST key. "AL" will show on the left display and "----" on the right display when there are no alarms in the list.
5. Upon clearing of the alarm queue, the alarm light will be turned off.

3.7.14 ISO Trip Header

DataLINE provides the user with an interface to view/modify current settings of the ISO trip header through the ISO Trip Header screen.

The ISO Trip Header screen is displayed when the user clicks on the "ISO Trip Header" button in the "Trip Functions" Group Box on the System Tools screen.

F9 function - Provides the user with a shortcut for manually triggering the refresh operation. Before sending modified parameter values, the user must ensure that a successful connection is established with the controller.

If the connection is established with the DataCORDER, the current contents of the ISO Trip Header from the DataCORDER will be displayed in each field. If the connection is not established with the DataCORDER, all fields on the screen will be displayed as "Xs." If at any time during the display of the ISO Trip Header screen the connection is not established or is lost, the user is alerted to the status of the connection.

After modifying the values and ensuring a successful connection has been made with the DataCORDER, click on the "Send" button to send the modified parameter values.

The maximum allowed length of the ISO Trip Header is 128 characters. If the user tries to refresh the screen or close the utility without sending the changes made on the screen to the DataCORDER, the user is alerted with a message.

Table 3-4 Controller Configuration Variables (Sheet 1 of 2)

CONFIGURATION NUMBER	TITLE	DEFAULT	OPTION
CnF02	Evaporator Fan Speed	dS (Dual)	SS (Single)
CnF03	Control Sensors	FOUr	duAL
CnF04	Dehumidification Mode	On	OFF
CnF06	Condenser Fan Speed Select	OFF (Single)	On (Variable)
CnF07	Unit Selection, 20FT/ 40FT/ 45FT	40ft	20ft,45
CnF08	Single Phase/3-Phase Evaporator Fan Motor	1Ph	3Ph
CnF09	Refrigerant Selection	r134a	r744
CnF10	Two Speed Compressor Logic	Out (Single)	In (Dual)
CnF11	Defrost "Off" Selection	noOFF	OFF
CnF14	Condenser Pressure Control (CPC)	In	Out
CnF15	Discharge Temperature Sensor	Out	In
CnF16	DataCORDER Present	On (Yes)	(Not Allowed)
CnF17	Discharge Pressure Sensor	Out (No)	In (Yes)
CnF18	Heater	Old (Low Watt)	nEW (High Watt)
CnF19	Controlled Atmosphere	Out (No)	In (Yes)
CnF20	Suction Pressure Sensor	Out (No)	In (Yes)
CnF21	Autotransformer	Out	In
CnF22	Economy Mode Option	OFF	Std, Full
CnF23	Defrost Interval Timer Save Option	noSAv	SAv
CnF24	Advanced Pre-Trip Enhanced Test Series Option	Auto	Auto2, Auto 3
CnF25	Pre-Trip Test Points/Results Recording Option	rSLtS	dAtA
CnF26	Heat Lockout Change Option	Set to -10C	Set to -5C
CnF27	Suction Temperature Display Option	Out	In
CnF28	Bulb Mode Option	NOr	bULb
CnF29	Arctic Mode	Out	In
CnF30	Compressor Size	41 CFM	37 CFM
CnF31	Probe Check Option	Std	SPEC
CnF32	Single Evaporator Fan Option	2EF0	(Not Allowed)
CnF33	Snap Freeze Option	OFF	SnAP
CnF34	Degree Celsius Lockout Option	bOth	F
CnF35	Humidification Mode	OFF	On
CnF37	Electronic Temperature Recorder	rEtUR	SUPPL, bOth
CnF39	Expanded Current Limit Range	Out	In
CnF40	Demand Defrost	Out	In

Table 3-4 Controller Configuration Variables (Sheet 2 of 2)

CONFIGURATION NUMBER	TITLE	DEFAULT	OPTION
CnF41	Lower DTT Setting	Out	In
CnF42	Auto Pre-trip Start	Out	In
CnF47	Fresh Air Vent Position Sensor	OFF	UPP,LOW,CUSTOM
CnF48	CFS Override	OFF	On
CnF49	DataCORDER Configuration Restore	OFF	On
CnF50	Enhanced Bulb Mode Selection	OFF	Bulb, dEHUM
CnF51	Timed Defrost Disable	0	0-out, 1-in
CnF52	Oil Return Algorithm	1	0-out, 1-in
CnF53	Water Cool Oil Return Logic	0	0-out, 1-in
CnF55	TXV Boost Relay	0	0-out, 1-in
CnF56	TXV Boost Circuit	0	0-out, 1-in
CnF58	Condenser Motor Type	0	0-1 ph, 1-3 ph
CnF59	Electronic Expansion Valve	0	0-none, 1-EC, 2-KE, 3- NA
CnF60	Compressor-Cycle Perishable Cooling	0	0-out, 1-in

Note: Configuration numbers not listed are not used in this application. These items may appear when loading configuration software to the controller but changes will not be recognized by the controller programming.

**Table 3-5 Controller Function Codes
(Sheet 1 of 4)**

Code No.	TITLE	DESCRIPTION
Note: If the function is not applicable, the display will read "-----"		
Display Only Functions		
Cd01	Digital Unloader Valve Opening (%)	Displays the DUV percent closed. The right display reads 100% when the valve is fully closed. The valve will usually be at 10% on start up of the unit except in very high ambient temperatures.
Cd03	Compressor Motor Current	The current sensor measures current draw in lines L1 & L2 by all of the high voltage components. It also measures current draw in compressor motor leg T3. The compressor leg T3 current is displayed.
Cd04	Line Current, Phase A	The current sensor measures current on two legs. The third unmeasured leg is calculated based on a current algorithm. The current measured is used for control and diagnostic purposes. For control processing, the highest of the Phase A and B current values is used for current limiting purposes. For diagnostic processing, the current draws are used to monitor component energization. Whenever a heater or a motor is turned ON or OFF, the current draw increase/reduction for that activity is measured. The current draw is then tested to determine if it falls within the expected range of values for the component. Failure of this test will result in a pre-trip failure or a control alarm indication.
Cd05	Line Current, Phase B	
Cd06	Line Current, Phase C	
Cd07	Main Power Voltage	The main supply voltage is displayed.
Cd08	Main Power Frequency	The value of the main power frequency is displayed in Hertz. The frequency displayed will be halved if either fuse F1 or F2 is bad (alarm code AL21).
Cd09	Ambient Temperature	The ambient sensor reading is displayed.
Cd10	Evaporator Temperature Sensor	Evaporator temperature sensor reading is shown on the right display.
Cd11	Compressor Discharge Temperature	Compressor discharge temperature sensor reading, using compressor dome temperature, is displayed.
Cd12	Compressor Suction Pressure	Reading for primary transducer (EPT) is shown on the right display. Press ENTER at Cd12 to show reading for secondary transducer (SPT) on left display.
Cd13	Not Applicable	Not used
Cd14	Compressor Discharge Pressure	Compressor discharges pressure transducer reading is displayed.
Cd15	Digital Unloader Valve	The status of the valve is displayed (Open - Closed).
Cd16	Compressor Motor Hour Meter	Records total hours of compressor run time. Total hours are recorded in increments of 10 hours (i.e., 3000 hours is displayed as 300).
Cd18	Software Revision #	The software revision number is displayed.
Cd19	Battery Check	This code checks the Controller/DataCORDER battery pack. While the test is running, "btest" will flash on the right display, followed by the result. "PASS" will be displayed for battery voltages greater than 7.0 volts. "FAIL" will be displayed for battery voltages between 4.5 and 7.0 volts, and "-----" will be displayed for battery voltages less than 4.5 volts. After the result is displayed for four seconds, "btest" will again be displayed, and the user may continue to scroll through the various codes.
Cd20	Config/Model #	This code indicates the dash number of the model for which the Controller is configured (i.e., if the unit is a 69NT40-551-100, the display will show "51100").
Cd21	Economizer Solenoid Valve	The status of the valve is displayed (Open - Closed).
Cd22	Compressor State	The status of the compressor is displayed (Off, On).
Cd23	Evaporator Fan	Displays the current evaporator fan state (high, low or off).
Cd24	Controlled Atmosphere State	Not used in this application.

Table 3-5 Controller Function Codes (Sheet 2 of 4)

Cd25	Compressor Run Time Remaining Until Defrost	This code displays the time remaining until the unit goes into defrost (in tenths of an hour). This value is based on the actual accumulated compressor running time.
Cd26	Defrost Temperature Sensor Reading	Defrost temperature sensor reading is displayed.
Configurable Functions		
NOTE		
Function codes Cd27 through Cd37 are user-selectable functions. The operator can change the value of these functions to meet the operational needs of the container.		
Cd27	Defrost Interval (Hours or Automatic)	<p>There are two modes for defrost initiation: user-selected timed intervals or automatic control. The user-selected values are (OFF), 3, 6, 9, 12, 24 hours or AUTO. The factory default is AUTO. Automatic defrost starts with an initial defrost at three hours, then the interval to the next defrost is adjusted based on the accumulation of ice on the evaporator coil. Following a start-up or after termination of a defrost, the time will not begin counting down until the defrost temperature sensor (DTS) reading falls below set point. If the reading of DTS rises above set point any time during the timer count down, the interval is reset and the count-down begins over. If DTS fails, alarm code AL60 is activated and control switches over to the the return temperature sensor. The controller will act in the same manner as with the DTS except the return temperature sensor reading will be used.</p> <p><i>Defrost Interval Timer Value (Configuration variable CnF23):</i> If the software is configured to "SAV" (save) for this option, the value of the defrost interval timer will be saved at power down and restored at power up. This option prevents short power interruptions from resetting an almost expired defrost interval, and possibly delaying a needed defrost cycle.</p> <p style="text-align: center;">NOTE</p> <p style="text-align: center;">The defrost interval timer counts only during compressor run time.</p>
Cd28	Temperature Units (C or F)	<p>This code determines the temperature units (C or F) that will be used for all temperature displays. The user selects C or F by selecting function code Cd28 and pushing the ENTER key. The factory default value is Celsius units.</p> <p style="text-align: center;">NOTE</p> <p style="text-align: center;">This function code will display "----" if Configuration Variable CnF34 is set to F.</p>
Cd29	Failure Action (Mode)	<p>If all of the control sensors are out of range (alarm code AL26) or there is a probe circuit calibration failure (alarm code AL27), the unit will enter the shutdown state defined by this setting. The user selects one of four possible actions as follows:</p> <p>A - Full Cooling (Compressor is on, economized operation.) B - Partial Cooling (Compressor is on, standard operation.) C - Evaporator Fan Only (Evaporator fans on high speed, not applicable with frozen set points.) D - Full System Shutdown - Factory Default (Shut down every component in the unit.)</p>
Cd30	In-Range Tolerance	<p>The in-range tolerance will determine the band of temperatures around the set point which will be designated as in-range. If the control temperature is in-range, the in-range light will be illuminated. There are four possible values:</p> <p>1 = +/- 0.5C (+/- 0.9F) 2 = +/- 1.0C (+/- 1.8F) 3 = +/- 1.5C (+/- 2.7F) 4 = +/- 2.0C (+/- 3.6F) - Factory Default</p>
Cd31	Stagger Start Offset Time (Seconds)	<p>The stagger start offset time is the amount of time that the unit will delay at start-up, thus allowing multiple units to stagger their control initiation when all units are powered up together. The eight possible offset values are: 0 (Factory Default), 3, 6, 9, 12, 15, 18 or 21 seconds</p>

Table 3-5 Controller Function Codes (Sheet 3 of 4)

Cd32	Current Limit (Amperes)	The current limit is the maximum current draw allowed on any phase at any time. Limiting the unit's current reduces the load on the main power supply. When desirable, the limit can be lowered. Note, however, that capacity is also reduced. The five values for 460 VAC operation are: 15, 17, 19, 21, or 23 amperes. The factory default setting is 21 amperes.
Cd33	Perishable Mode Dehumidification Control (% RH)	Relative humidity set point is available only on units configured for dehumidification. When the mode is activated, the control probe LED flashes on and off every second to alert the user. If not configured, the mode is permanently deactivated and "----" will display. The value can be set to "OFF," "TEST," or a range of 65 to 95% relative humidity in increments of 1%. [If bulb mode is active (code Cd35) and "Lo" speed evaporator motors are selected (code Cd36), then set point ranges from 60 to 95%.] When "TEST" is selected or test set point is entered, the heat LED should illuminate, indicating that dehumidification mode is activated. After a period of five minutes in the "TEST" mode has elapsed, the previously selected mode is reinstated.
Cd34	Economy Mode (On-Off)	Economy mode is a user selectable mode of operation provided for power saving purposes.
Cd35	Bulb Mode	Bulb mode is a user selectable mode of operation that is an extension of dehumidification control (Cd33). If dehumidification is set to "Off," code Cd35 will display "Nor" and the user will be unable to change it. After a dehumidification set point has been selected and entered for code Cd33, the user may change code Cd35 to "bulb." After bulb has been selected and entered, the user may utilize function codes Cd36 and Cd37 to make the desired changes.
Cd36	Evaporator Speed Select	This code is enabled only if in the dehumidification mode (code Cd33) and bulb mode (Cd35) has been set to "bulb." If these conditions are not met, "alt" will be displayed (indicating that the evaporator fans will alternate their speed) and the display cannot be changed. If a dehumidification set point has been selected along with bulb mode, "alt" may be selected for alternating speed, "Lo" for low speed evaporator fan only, or "Hi" for high speed evaporator fan only. If a setting other than "alt" has been selected and bulb mode is deactivated in any manner, the selection reverts back to "alt."
Cd37	Defrost Termination Temperature Setting (Bulb Mode)	This code, as with function code Cd36, is used in conjunction with bulb mode and dehumidification. If bulb mode is active, this code allows the user to change the temperature above which defrost will terminate. It allows the user to change the setting within a range of 4C to 25.6C in 0.1C (0.2F) increments. This value is changed using the UP/DOWN ARROW keys, followed by the ENTER key when the desired value is displayed. If bulb mode is deactivated, the DTS setting returns to the default.
Display Only Functions - Continued		
Cd38	Secondary Supply Temperature Sensor	Code Cd38 will display the current secondary supply temperature sensor (SRS) reading for units configured for four probes. If the unit is configured with a DataCORDER, Cd38 will display "----." If the DataCORDER suffers a failure, (AL55) Cd38 will display the supply recorder sensor reading.
Cd39	Secondary Return Temperature Sensor	Code Cd39 will display the current secondary return temperature sensor (RRS) reading for units configured for four probes. If the unit is configured with a DataCORDER, Cd39 will display "----." If the DataCORDER suffers a failure, (AL55) Cd39 will display the return recorder sensor reading.
Cd40	Container Identification Number	Code Cd40 is configured at commissioning to read a valid container identification number. The reading will not display alpha characters; only the numeric portion of the number will display.
Cd41	Valve Override	SERVICE FUNCTION: This code is used for troubleshooting, and allows manual positioning of the economizer and oil return valves. Refer to paragraph 6.16 for operating instructions.
Cd45	Fresh Air Vent Position Sensor	Unless AL50 is active or CnF47 is OFF, the fresh air flow (CMH/CFM) is displayed. This function code will automatically activate for 30 seconds and displayed when a vent position change occurs.
Cd46	Airflow Display Units	This code displays the airflow units to be displayed for Cd 45. Options are CF, CM or bOth (dependant on the setting of Cd28 or pressing of the C/F key.

Table 3-5 Controller Function Codes (Sheet 4 of 4)

Cd47	Variable Economy Temperature Setting	Code Cd47 is used with optional economy mode. The values are 0.5C-4.0C. The default is 3.0C. If the unit is not configured for economy mode, "----" will be displayed.
Cd48	Dehumidification Parameter Selection	Code Cd48 is used both when dehumidification set point is set above 65% RH and below 64% RH. When dehumidification set point is set above 65% RH, select goes to LO if it had been set to hi. When dehumidification set point is set below 64% RH, select goes to Alt if it had been set to LO.
Cd49	Days Since Last Successful Pre-trip	Code Cd49 will display the time period (days) since the last successful pre-trip.
Cd51	Automatic Cold Treatment Parameter Selection	Code Cd51 initially displays countdown timer increments of 1 day, 1 hour with the temperature default. Pressing ENTER allows selection of within the current menu and proceeds to the next menu. After five seconds of no activity, the display reverts to normal system display, but retains the parameters previously selected. "ACT" = "On," "Off" or "----". The default is Off. "trEAt"=C /F in 0.1 degree increments. The default is 0.0C. "DAyS"= "0-99" increments of 1. The default is 0. "ProbE"=probe positions (example 12_4) . The default is ----. "SPnEW"= C /F in 0.1 degree increments. The default is 10.0C.
Cd53	Automatic Set point Change Mode Parameter Selection	Code Cd53 initially displays countdown timer increments of 1 day, 1 hour with the temperature default. Pressing ENTER allows selection of within the current menu and proceeds to the next menu. After five seconds of no activity, the display reverts to normal system display, but retains the parameters previously selected. "ASC"="On" or "Off" The default is Off. "NSC"="1-2" "SP 0"=C /F in 0.1 degree increments. The default is 10.0C. "DAY 0"= "0-99" increments of 1. The default is 1. "SP 1"=C /F in 0.1 degree increments. The default is 10.0C. "DAY 1"= "0-99" increments of 1. The default is 1. "SP 2"=C /F in 0.1 degree increments. The default is 10.0C.
Cd54	Electronic Expansion Valve Status	Reading for evaporator superheat is shown on the right display. Press ENTER at Cd54 to show reading for EEV position (in %) on left display.
Cd55	Discharge Superheat	Code Cd55 will display the discharge superheat values in C /F as calculated by the discharge temperature minus the discharge saturation temperature as calculated from discharge pressure. "-----" will be displayed if the selection is not valid.

Table 3-6 Controller Alarm Indications (Sheet 1 of 4)

Code No.	TITLE	DESCRIPTION
AL03	Loss of Superheat Control	Alarm 03 is triggered if superheat operates below 1.66C (3F) for five minutes continuously while the compressor is running and the EEV is at 0% open. The alarm will trigger off when superheat has remained above 1.66C (3F) for five minutes continuously while the compressor is running.
AL05	Manual Defrost Switch Failure	Alarm 05 is triggered if the controller detects continuous Manual Defrost Switch action for five minutes or more. The alarm will only trigger off when the unit is power cycled.
AL06	Keypad or Harness Failure	Alarm 06 is triggered if the controller detects continuous keypad button activity for five minutes or more. The alarm will only trigger off when the unit is power cycled.
AL07	Fresh Air Vent Open with Frozen Set Point	Alarm 07 is triggered if the VPS is reading greater than 0 CMH based on the function code display value and a frozen set point is active. If AL 50 is active, AL 07 will not be generated. The alarm will go inactive if the VPS reading transitions to 0 CMH, the set point transitions to the perishable range, or an AL50 is active.
AL08	High Compressor Pressure Ratio	Alarm 08 is triggered when the controller detects that the discharge pressure to suction pressure ratio is too high. The alarm triggers shut down of the compressor, which will restart in normal staging logic, after three minutes.
AL14	Phase Sequence Failure - Electronic	Alarm 14 is triggered if the electronic phase detection system is unable to determine the correct phase relationship. AL 14 is also triggered if electronic phase sequence detection was successful and conclusive, but unit is miswired. The miswiring causes increased suction pressure and decreased discharge pressure when the compressor is running; these conditions are present only when the compressor is energized in the direction opposite of that indicated by electronic phase sequence detection. If the system is unable to determine the proper relationship, alarm 14 will remain active. Additional information on phase detection may be displayed at Function Code Cd41. If the right most digit of Code Cd41 is 3 or 4, this indicates incorrect motor or sensor wiring. If the right most digit is 5, this indicates a failed current sensor assembly.
AL16	Compressor Current High	Alarm 16 is triggered if compressor current draw is 15% over calculated maximum for 10 minutes out of the last hour. The alarm is display only and will trigger off when the compressor operates for one hour without over current.
AL17	Phase Sequence Failure - Pressure	Alarm 17 is triggered if a compressor start in both directions fails to generate sufficient pressure differential. The controller will attempt restart every 20 minutes and deactivate the alarm if successful. This alarm triggers failure action C (evaporator fan only) or D (all machinery off) of Function Code Cd29 if the unit has a perishable set point. Failure action D (all machinery off) is triggered if the unit has a frozen set point.
AL18	Discharge Pressure High	Alarm 18 is triggered if discharge pressure is 10% over calculated maximum for 10 minutes within the last hour. The alarm is display only and will trigger off when the compressor operates for one hour without overpressure.
AL19	Discharge Temperature High	Alarm 19 is triggered if discharge temperature exceeds 135C (275F) for 10 minutes within the last hour. The alarm is display only and will trigger off when the compressor operates for one hour without over temperature.
AL20	Control Circuit Fuse Open (24 VAC)	Alarm 20 is triggered by control power fuse (F3A, F3B) opening and will cause the software shutdown of all control units. This alarm will remain active until the fuse is replaced.

Table 3-6 Controller Alarm Indications (Sheet 2 of 4)

AL21	Micro Circuit Fuse Open (18 VAC)	Alarm 21 is triggered by one of the fuses (F1/F2) being opened on 18 VAC power supply to the controller. Temperature control will be maintained by cycling the compressor.
AL22	Evaporator Fan Motor Safety	Alarm 22 responds to the evaporator motor internal protectors. On units with Normal Evaporator Fan Operation (CnF32 set to 2EFO), the alarm is triggered by opening of either internal protector. It will disable all control units until the motor protector resets. On units with Single Evaporator Fan Capability (CnF32 set to 1EFO), the alarm is triggered by opening of both internal protectors. It will disable all control units until a motor protector resets.
AL23	Loss of Phase B	Alarm 23 is triggered if low current draw is detected on phase B and IPCP, HPS or IPEM is not tripped. If the compressor should be running, the controller will initiate a start up every five minutes and trigger off if current reappears. If the evaporator fan motors only should be running, the alarm will trigger off if current reappears. This alarm triggers failure action C (evaporator fan only) or D (all machinery off) of Function Code Cd29 if the unit has a perishable set point. Failure action D (all machinery off) is triggered if the unit has a frozen set point.
AL24	Compressor Motor Safety	Alarm 24 is triggered when compressor is not drawing any current. It also triggers failure action "C" or "D" set by function Code 29 for perishable set point, or "D" for frozen set point. If the compressor should be running, the controller will initiate a start up every five minutes and trigger off, if current reappears. This alarm will remain active until compressor draws current.
AL25	Condenser Fan Motor Safety	Alarm 25 is triggered by the opening of the condenser motor internal protector and will disable all control units except for the evaporator fans. This alarm will remain active until the motor protector resets. This alarm triggers failure action C (evaporator fan only) or D (all machinery off) of Function Code Cd29 if the unit has a perishable set point. Failure action D (all machinery off) is triggered if the unit has a frozen set point.
AL26	All Supply and Return temperature Control Sensors Failure	Alarm 26 is triggered if the controller determines that all of the control sensors are out-of-range. This can occur for box temperatures outside the range of -50C to +70C (-58F to +158F). This alarm triggers the failure action code set by Function Code Cd29.
AL27	A/D Accuracy Failure	The controller has a built-in Analog to Digital (A-D) converter, used to convert analog readings (i.e. temperature sensors, current sensors, etc.) to digital readings. The controller continuously performs calibration tests on the A-D converter. If the A-D converter fails to calibrate for 30 consecutive seconds, this alarm is activated. This alarm will be inactivated as soon as the A-D converter calibrates.
AL28	Low Suction Pressure	Alarm 28 is triggered if evaporator pressure is invalid. This alarm triggers shut down of the compressor off for three minutes. This alarm will be inactivated when suction pressure rises above 2 psia for three continuous minutes.
AL29	AutoFresh Failure	Alarm 29 is triggered if CO2 or O2 level is outside of the limit range and the vent position is at 100% for longer than 90 minutes. Alarm LED will be activated and user intervention is required. The alarm is triggered off when atmospheric conditions are within limit settings.
AL50	Fresh Air Position Sensor (VPS)	Alarm 50 is activated whenever the sensor is outside the valid range. There is a four-minute adjustment period where the user can change the vent position without generating an alarm event. The sensor requires four minutes of no movement to confirm stability. If the vent position changes at any point beyond the four-minute adjustment period, the sensor will generate an alarm event. The alarm is triggered off when the unit power cycles and the sensor is within valid range.
AL51	Alarm List Failure	During start-up diagnostics, the EEPROM is examined to determine validity of its contents. This is done by testing the set point and the alarm list. If the contents are invalid, alarm 51 is activated. During control processing, any operation involving alarm list activity that results in an error will cause alarm 51 to be activated. Alarm 51 is a "display only" alarm and is not written into the alarm list. Pressing the ENTER key when "CLEAR" is displayed will result in an attempt to clear the alarm list. If that action is successful (all alarms are inactive), alarm 51 will be reset.
AL52	Alarm List Full	Alarm 52 is activated whenever the alarm list is determined to be full at start-up or after recording an alarm in the list. Alarm 52 is displayed, but is not recorded in the alarm list. This alarm can be reset by clearing the alarm list. This can be done only if all alarms written in the list are inactive.

Table 3-6 Controller Alarm Indications (Sheet 3 of 4)

AL53	Battery Pack Failure	Alarm 53 is caused by the battery pack charge being too low to provide sufficient power for battery-backed recording. If this alarm occurs on start up, allow a unit fitted with rechargeable batteries to operate for up to 24 hours to charge rechargeable batteries sufficiently to deactivate the alarm.
AL54	Primary Supply Temperature Sensor Failure (STS)	Alarm 54 is activated by an invalid supply temperature sensor (STS) reading that is sensed outside the range of -50 to +70C (-58F to +158F) or if the probe check logic has determined there is a fault with this sensor. If alarm 54 is activated and the primary supply is the control sensor, the secondary supply sensor (SRS) will be used for control if the unit is so equipped. If the unit does not have a secondary supply temperature sensor, and AL54 is activated, the primary return sensor reading minus 2C will be used for control. NOTE The P5 Pre-Trip test must be run to inactivate the alarm.
AL55	I/O Failure	This alarm activates to indicate I/O functions have failed and require replacement.
AL56	Primary Return Temperature Sensor Failure (RTS)	Alarm 56 is activated by an invalid primary return temperature sensor (RTS) reading that is outside the range of -50 to +70C (-58F to +158F). If alarm 56 is activated and the primary return is the control sensor, the secondary return sensor (RRS) will be used for control if the unit is so equipped. If the unit is not equipped with a secondary return temperature sensor or it fails, the primary supply sensor will be used for control. NOTE The P5 Pre-Trip test must be run to inactivate the alarm.
AL57	Ambient Temperature Sensor Failure	Alarm 57 is triggered by an ambient temperature reading outside the valid range from -50 to +70C (-58F to +158F).
AL58	Compressor High Pressure Safety	Alarm 58 is triggered when the compressor high discharge pressure safety switch remains open for at least one minute. This alarm will remain active until the pressure switch resets, at which time the compressor will restart.
AL59	Heater Termination Thermostat (HTT)	Alarm 59 is triggered when the heat termination thermostat switch is opened (except when defrost sensor alarm is active). This alarm will remain active until the heat termination thermostat closes.
AL60	Defrost Temperature Sensor Failure	Alarm 60 is an indication of a probable failure of the defrost temperature sensor (DTS). It is triggered by the opening of the heat termination thermostat (HTT) or the failure of the DTS to go above set point within two hours of defrost initiation. After one-half hour with a frozen range set point, or one-half hour of continuous compressor run time, if the return air falls below 7C (45F), the controller checks to ensure the DTS reading has dropped to 10C or below. If not, a DTS failure alarm is given and the defrost mode is operated using the return temperature sensor. The defrost mode will be terminated after one hour by the controller.
AL61	Heaters Failure	Alarm 61 is triggered by detection of improper amperage resulting from heater activation or deactivation. Each phase of the power source is checked for proper amperage. This alarm is a display alarm with no resulting failure action and will be reset by a proper amp draw of the heater.
AL62	Compressor Circuit Failure	Alarm 62 is triggered by improper current draw increase (or decrease) resulting from compressor turn on (or off). The compressor is expected to draw a minimum of 2 amps; failure to do so will activate the alarm. This is a display alarm with no associated failure action and will be reset by a proper amp draw of the compressor.
AL63	Current Over Limit	Alarm 63 is triggered by the current limiting system. If the compressor is ON and current limiting procedures cannot maintain a current level below the user selected limit, the current limit alarm is activated. This alarm is a display alarm and is inactivated by power cycling the unit, changing the current limit via the code select Cd32, or if the current decreases below the activation level.
AL64	Discharge Temperature Over Limit	Alarm 64 is triggered if the discharge temperature sensed is outside the range of -60C (-76F) to 175C (347F), or if the sensor is out of range. This is a display alarm and has no associated failure action.
AL65	Discharge Pressure Transducer Failure	Alarm 65 is triggered if a compressor discharge transducer is out of range. This is a display alarm and has no associated failure action.

Table 3-6 Controller Alarm Indications (Sheet 4 of 4)

AL66	Evaporator Pressure Transducer Out of Range	Alarm 66 is triggered if an evaporator pressure transducer is less than 0.2 volts or greater than 4.95 volts. When alarm 66 is triggered on, use the Suction port pressure to calculate superheat. Alarm is triggered off when evaporator pressure sensor is back in range.	
AL67	Humidity Sensor Failure	Alarm 67 is triggered by a humidity sensor reading outside the valid range of 0% to 100% relative humidity. If alarm AL67 is triggered when the dehumidification mode is activated, then the dehumidification mode will be deactivated.	
AL68	Condenser Pressure Sensor Fault	Alarm 68 is triggered when the Condenser Pressure Sensor is out of range. This is a display alarm and has no associated failure action.	
AL69	Primary Evaporator Temperature Sensor Out of Range	Alarm 69 is triggered when the primary evaporator temperature sensor (ETS1) is out of range. The controller switches to use of the secondary evaporator temperature sensor (ETS2). This is a display alarm and triggered off when ETS1 is back within range.	
NOTE			
If the controller is configured for four probes without a DataCORDER, the DataCORDER alarms AL70 and AL71 will be processed as Controller alarms AL70 and AL71. Refer to Table 3-10, page 3-33.			
ERR #	Internal Microprocessor Failure	The controller performs self-check routines. If an internal failure occurs, an "ERR" alarm will appear on the display. This is an indication the controller needs to be replaced.	
		ERROR	
		DESCRIPTION	
		ERR 0-RAM failure	Indicates that the controller working memory has failed.
		ERR 1-Program Memory failure	Indicates a problem with the controller program.
		ERR 2-Watchdog time-out	The controller program has entered a mode whereby the controller program has stopped executing.
		ERR 3-N/A	N/A
		ERR 4-N/A	N/A
		ERR 5-A-D failure	The controller's Analog to Digital (A-D) converter has failed.
		ERR 6-IO Board failure	Internal program/update failure.
		ERR 7-Controller failure	Internal version/firmware incompatible.
		ERR 8-DataCORDER failure	Internal DataCORDER memory failure.
ERR 9-Controller failure	Internal controller memory failure.		
		In the event that a failure occurs and the display cannot be updated, the status LED will indicate the appropriate ERR code using Morse code as shown below.	
		E R R 0 to 9	
		ERR0 =	
		ERR1 =	
		ERR2 =	
		ERR3 =	
		ERR4 =	
		ERR5 =	
		ERR6 =	
		ERR7 =	
		ERR8 =	
		ERR9 =	
Entr StPt	Enter Set point (Press Arrow & Enter)	The controller is prompting the operator to enter a set point.	
LO	Low Main Voltage (Function Codes Cd27-38 disabled and NO alarm stored.)	This message will be alternately displayed with the set point whenever the supply voltage is less than 75% of its proper value.	

Table 3-7 Controller Pre-Trip Test Codes (Sheet 1 of 4)

Code No.	TITLE	DESCRIPTION
<p align="center">NOTE</p> <p>“Auto” or “Auto1” menu includes the: P0, P1, P2, P3, P4, P5, P6 and rSLts. “Auto2” menu includes P0, P1, P2, P3, P4, P5, P6, P7, P8, P9, P10 and rSLts. “Auto3” menu includes P0, P1, P2, P3, P4, P5, P6, P7 and P8.</p>		
P0-0	Pre-Trip Initiated	All lights and display segments will be energized for five seconds at the start of the pre-trip. Since the unit cannot recognize lights and display failures, there are no test codes or results associated with this phase of pre-trip.
P1-0	Heaters Turned On	Setup: Heater must start in the OFF condition, and then be turned on. A current draw test is done after 15 seconds. Pass/Fail Criteria: Passes if current draw change is within the range specified.
P1-1	Heaters Turned Off	Setup: Heater must start in the ON condition, and then be turned off. A current draw test is done after 10 seconds. Pass/Fail Criteria: Passes if current draw change is within the range specified.
P2-0	Condenser Fan On	Requirements: Water pressure switch or condenser fan switch input must be closed. Setup: Condenser fan is turned ON, a current draw test is done after 15 seconds. Pass/Fail Criteria: Passes if current draw change is within the range specified.
P2-1	Condenser Fan Off	Setup: Condenser fan is turned OFF, a current draw test is done after 10 seconds. Pass/Fail Criteria: Passes if current draw change is within the range specified.
P3	Low Speed Evaporator Fans	<p>Requirements: The unit must be equipped with a low speed evaporator fan, as determined by the Evaporator Fan speed select configuration variable.</p> <p align="center">NOTE</p> <p>If the unit is configured for single evaporator fan operation, Pre-Trip tests P3-0, P3-1, P4-0 and P4-1 will fail immediately if Controller alarm codes AL11 or AL12 are active at the start of testing.</p>
P3-0	Low Speed Evaporator Fan Motors On	Setup: The High Speed Evaporator fans will be turned on for 10 seconds, then off for two seconds, then the low speed evaporator fans are turned on. A current draw test is done after 60 seconds. Pass/Fail Criteria: Passes if change in current draw is within the range specified. Fails if AL11 or AL12 activates during test for units operating with single fan only.
P3-1	Low Speed Evaporator Fan Motors Off	Setup: The Low Speed Evaporator fan is turned off, a current draw test is done after 10 seconds. Pass/Fail Criteria: Passes if change in current draw is within the range specified. Fails if AL11 or AL12 activates during test for units operating with single fan only.
P4-0	High Speed Evaporator Fan Motors On	Setup: The high speed evaporator fan is turned on, a current draw test is done after 60 seconds. Pass/Fail Criteria: Passes if change in current draw is within the range specified. Fails if AL11 or AL12 activates during test for units operating with single fan only.
P4-1	High Speed Evaporator Fan Motors Off	Setup: The high speed evaporator fan is turned off, a current draw test is done after 10 seconds. Pass/Fail Criteria: Passes if change in current draw is within the range specified. Fails if AL11 or AL12 activates during test.

Table 3-7 Controller Pre-Trip Test Codes (Sheet 2 of 4)

P5-0	Supply/Return Probe Test	<p>Setup: The High Speed Evaporator Fan is turned on and run for eight minutes, with all other outputs de-energized.</p> <p>Pass/Fail Criteria: A temperature comparison is made between the return and supply probes.</p> <p style="text-align: center;">NOTE</p> <p>If this test fails, "P5-0" and "FAIL" will be displayed. If both Probe tests (this test and the PRIMARY/ SECONDARY) pass, the display will read "P5" "PASS."</p>
P5-1	Supply Probe Test	<p>Requirements: For units equipped with secondary supply probe only.</p> <p>Pass/Fail Criteria: The temperature difference between primary (STS) and secondary (SRS) probe (supply) is compared.</p> <p style="text-align: center;">NOTE</p> <p>If this test fails, "P5-1" and "FAIL" will be displayed. If both Probe tests (this and the SUPPLY/RETURN TEST) pass, because of the multiple tests, the display will read "P 5" "PASS."</p>
P5-2	Return Probe Test	<p>Requirements: For units equipped with secondary return probe only.</p> <p>Pass/Fail Criteria: The temperature difference between primary (RTS) and secondary (RRS) probe (return) is compared.</p> <p style="text-align: center;">NOTES</p> <ol style="list-style-type: none"> 1. If this test fails, "P5-2" and "FAIL" will be displayed. If both Probe tests (this test and the SUPPLY/RETURN) pass, because of the multiple tests, the display will read "P 5," "PASS." 2. The results of Pre-Trip tests 5-0, 5-1 and 5-2 will be used to activate or clear control probe alarms.
P5-3	Evaporator Fan Direction Test	<p>Requirements: Test P5-0 must pass before this test is run.</p> <p>Setup: While the evaporator is running on high speed, the temperature differential between primary supply (STS) and primary return (RTS) probes is measured, with and without heaters energized.</p> <p>Pass/Fail Criteria: Passes if differential of primary supply temperature is 0.25 degree C higher than primary return temperature.</p>
P5-7	Primary .vs Secondary Evaporator Temperature Sensor Test	<p>Pass/Fail Criteria: Passes if secondary evaporator temperature sensor (ETS2) is within +/- 0.5 degree C of the primary evaporator temperature sensor (ETS1).</p>
P5-9	Primary .vs Secondary Suction (Evaporator) Pressure Transducer Test	<p>Pass/Fail Criteria: Passes if secondary transducer (SPT) is within +/- 1.5 psi of the primary transducer (EPT).</p>
P5-10	Humidity Sensor Controller Configuration Verification Test	<p>Requirements: Test P5-9 must pass before this test is run. Test is skipped if controller is not configured for the humidity sensor and the voltage is less than 0.20 volts.</p> <p>Pass/Fail Criteria: Passes if controller configuration has the humidity sensor installed. Fails if controller is not configured for humidity sensor and the voltage is greater than 0.20 volts.</p>
P5-11	Humidity Sensor Installation Verification Test	<p>Requirements: Test P5-10 must pass before this test is run.</p> <p>Pass/Fail Criteria: Passes if voltage is greater than 0.20 volts for the humidity sensor. Fails if voltage is less than 0.20 volts for the humidity sensor.</p>
P5-12	Humidity Sensor Range Check Test	<p>Requirements: Test P5-11 must pass before this test is run.</p> <p>Pass/Fail Criteria: Passes if the voltage for the humidity sensor is between 0.66 volts and 4 volts. Fails if voltage is outside of the 0.66 volt to 4 volt range.</p>

Table 3-7 Temperature Controller Pre-Trip Test Codes (Sheet 3 of 4)

P6-0	Discharge Thermistor Test	If alarm 64 is activated any time during the first 45 second period of Step 1, the test fails.
P6-1	Suction Thermistor Test	Alarm is activated if suction temperature is outside of the valid range of -60C (-76F) to 150C (302F) any time during the first 45 second period of Step 1, the test fails.
P6-2	Discharge Pressure Sensor Test	If alarm 65 is activated any time during the first 45 second period of Step 1, the test fails.
P6-3	Suction Pressure Sensor Test	If alarm 66 is activated, the test fails.
P6-4	Compressor Current Draw Test	Compressor current is tested before and 10 seconds after start up. If current does not increase, the test fails. P6-7 is run at the end of P6-4. If this test fails, P6-6 is skipped.
NOTE		
<p>P6-6 through P6-10 tests are conducted by changing the status of each individual valve and comparing suction pressure change and/or compressor current change with predetermined values. The tests will cause the compressor and condenser fans to cycle on and off as needed to generate the pressure required for the individual pre-trip sub tests. The compressor will start in order to build discharge pressure, followed by a compressor pump down sequence. At the conclusion of the compressor pump down sequence, the compressor will shut down and the valve test will start.</p>		
P6-6	Economizer Valve Test	Passes if suction pressure increases a minimum of 4 psi when the valve opens for 15 seconds.
P6-7	Digital Unloader Valve Test	Passes if pressure and current changes are within 3 seconds of DUV switch signal and either the pressure change or the current draw change is above 5 psi or above 1.5A, respectively.
P6-9	Liquid Injection Valve Test	Passes if increase in suction pressure reaches above 4 psi when the valve opens for 15 seconds.
P6-10	Electronic Expansion Valve Test	Pass/Fail Criteria: The test records the suction pressure during the open valve position and passes if the suction pressure increase is above 3 psi when the valve opens for 10 seconds.
NOTE		
<p>P7-0 & P8 are included with "Auto2 & Auto 3" only. P9-0 through P10 are included with "Auto2" only.</p>		
NOTE		
P7-0	High Pressure Switch Open	<p>This test is skipped if the sensed ambient temperature is less than 7C (45F), the return air temperature is less than -17.8C (0F), the water pressure switch is open or the condenser fan switch is open.</p> <p>Setup: With the unit running, the condenser fan is turned off and a 900 second (15 minute) timer is started. The right display shows the value of the initial sensor configured and valid out of the discharge pressure, CPC pressure, discharge temperature.</p> <p>Pass/Fail Criteria: The test fails immediately if:</p> <ul style="list-style-type: none"> -all three sensors are not configured or are invalid. -the ambient temperature or return air temperature sensors are invalid at the start of the test. <p>The test fails if:</p> <ul style="list-style-type: none"> -the high pressure switch if open at the start of the test. -the high pressure switch fails to open within 15 minutes. -a valid discharge temperature exceeds 137.78 C (280 F). -a valid discharge pressure or valid condensing pressure exceeds 390 psig. <p>The test passes if the high pressure switch opens within the 15 minute time limit and before any of the valid and configured sensors exceed their limits.</p>
P7-1	High Pressure Switch Closed	<p>Requirements: Test P7-0 must pass for this test to execute. Setup: The condenser fan is started and a 60 second timer is started.</p> <p>Pass/Fail Criteria: Passes the test if the high pressure switch (HPS) closes within the 60 second time limit, otherwise, it fails.</p>

Table 3-7 Temperature Controller Pre-Trip Test Codes (Sheet 4 of 4)

P8-0	Perishable Mode Heat Test	<p>Setup: If the container temperature is below 15.6C (60F), the set point is changed to 15.6C, and a 180-minute timer is started. The left display will read "P8-0." The control will then heat the container until 15.6C is reached. If the container temperature is above 15.6C at the start of the test, then the test proceeds immediately to test P8-1 and the left display will change to "P8-1."</p> <p>Pass/Fail Criteria: The test fails if the 180 minute timer expires before the control temperature reaches set point. The display will read "P8-0," "FAIL."</p>
P8-1	Perishable Mode Pulldown Test	<p>Requirements: Control temperature must be at least 15.6C (60F).</p> <p>Setup: The set point is changed to 0C (32F), and a 180-minute timer is started. The left display will read "P8-1," the right display will show the supply air temperature. The unit will then start to pull down the temperature to the 0C set point.</p> <p>Pass/Fail Criteria: The test passes if the container temperature reaches set point before the 180 minute timer expires.</p>
P8-2	Perishable Mode Maintain Temperature Test	<p>Requirements: Test P8-1 must pass for this test to execute. This test is skipped if the DataCORDER is not configured or not available.</p> <p>Setup: A 15-minute timer is started. The unit will be required to minimize control temperature error (supply temperature minus set point) until the timer expires. The control temperature will be sampled at least once each minute starting at the beginning of P8-2.</p> <p>Pass/Fail Criteria: If the average recorded temperature is within +/- 1.0C (1.8F) of set point, the test passes. If the average temperature is outside of the tolerance range or if the DataCORDER supply temperature probe is invalid, the test fails and the control probe temperature will be recorded as -50.0C. P8-2 will auto-repeat by starting P8-0 over.</p>
P9-0	Defrost Test	<p>Setup: The defrost temperature sensor (DTS) reading will be displayed on the left display. The right display will show the supply air temperature. The unit will run FULL COOL for 30 minutes maximum until the DTT is considered closed. Once the DTT is considered closed, the unit simulates defrost by running the heaters for up to two hours, or until the DTT is considered open.</p> <p>Pass/Fail Criteria: The test fails if: the DTT is not considered closed after the 30 minutes of full cooling, HTT opens when DTT is considered closed or if return air temperature rises above 49C (120F).</p>
P10-0	Frozen Mode Heat Test	<p>Setup: If the container temperature is below 7.2C (45F), the set point is changed to 7.2C and a 180-minute timer is started. The control will then be placed in the equivalent of normal heating. If the container temperature is above 7.2C at the start of the test, then the test proceeds immediately to test 10-1. During this test, the control temperature will be shown in the right display.</p> <p>Pass/Fail Criteria: The test fails if the 180-minute timer expires before the control temperature reaches set point -0.3C (0.17F). If the test fails it will not auto-repeat. There is no pass display for this test. Once the control temperature reaches set point, the test proceeds to test 10-1</p>
P10-1	Frozen Mode Pull-down Test	<p>Requirements: Control temperature must be at least 7.2C (45F)</p> <p>Setup: The set point is changed to -17.8C (0F). The system will then attempt to pull down the control temperature to set point using normal frozen mode cooling. During this test, the control temperature will be shown on the right display.</p> <p>Pass/Fail Criteria: If the control temperature does not reach set point -0.3C (0.17F) before the 180-minute timer expires the test fails and will auto-repeat by starting P10-0 over.</p>
P10-2	Frozen Mode Maintain Temperature Test	<p>Requirements: Test P10-1 must pass for this test to execute. This test is skipped if the DataCORDER is not configured or not available.</p> <p>Setup: A 15-minute timer is started. The unit will be required to minimize return probe temperature error (supply temperature minus set point) until the timer expires. The return probe temperature will be sampled at least once each minute starting at the beginning of P10-2.</p> <p>Pass/Fail Criteria: If the average recorded temperature is within +/- 1.6C (+/- 2.9) of set point, the test passes. If the average temperature is outside of the tolerance range or if the DataCORDER return temperature probe is invalid, the test fails and the control probe temperature will be recorded as -50.0C. P10-2 will auto-repeat by starting P10-0 over.</p>

Table 3-8 DataCORDER Function Code Assignments

NOTE		
Inapplicable Functions Display “-----”		
To Access: Press ALT. MODE key		
Code No.	TITLE	DESCRIPTION
dC1	Recorder Supply Temperature	Current reading of the supply recorder sensor.
dC2	Recorder Return Temperature	Current reading of the return recorder sensor.
dC3-5	USDA 1,2,3 Temperatures	Current readings of the three USDA probes.
dC6-13	Network Data Points 1-8	Current values of the network data points (as configured). Data point 1 (Code 6) is generally the humidity sensor and its value is obtained from the controller once every minute.
dC14	Cargo Probe 4 Temperature	Current reading of the cargo probe #4.
dC15-19	Future Expansion	These codes are for future expansion, and are not in use at this time.
dC20-24	Temperature Sensors 1-5 Calibration	Current calibration offset values for each of the five probes: supply, return, USDA #1, #2, and #3. These values are entered via the interrogation program.
dC25	Future Expansion	This code is for future expansion, and is not in use at this time.
dC26,27	S/N, Left 4, Right 4	The DataCORDER serial number consists of eight characters. Function code dC26 contains the first four characters. Function code dC27 contains the last four characters. (This serial number is the same as the controller serial number.)
dC28	Minimum Days Left	An approximation of the number of logging days remaining until the DataCORDER starts to overwrite the existing data.
dC29	Days Stored	Number of days of data that are currently stored in the DataCORDER.
dC30	Date of last Trip start	The date when a Trip Start was initiated by the user. In addition, if the system goes without power for seven continuous days or longer, a trip start will automatically be generated on the next AC power up. Press and hold “ENTER” key for five seconds to initiate a “Trip Start.”
dC31	Battery Test	Shows the current status of the optional battery pack. PASS: Battery pack is fully charged. FAIL: Battery pack voltage is low.
dC32	Time: Hour, Minute	Current time on the real time clock (RTC) in the DataCORDER.
dC33	Date: Month, Day	Current date (month and day) on the RTC in the DataCORDER.
dC34	Date: Year	Current year on the RTC in the DataCORDER.
dC35	Cargo Probe 4 Calibration	Current calibration value for the Cargo Probe. This value is an input via the interrogation program.

Table 3-9 DataCORDER Pre-Trip Result Records

Test No.	TITLE	DATA
1-0	Heater On	Pass/Fail/Skip Result, Change in current for Phase A, B and C
1-1	Heater Off	Pass/Fail/Skip Result, Change in currents for Phase A, B and C
2-0	Condenser Fan On	Pass/Fail/Skip Result, Water pressure switch (WPS) - Open/Closed, Change in currents for Phase A, B and C
2-1	Condenser Fan Off	Pass/Fail/Skip Result, Change in currents for Phase A, B and C
3-0	Low Speed Evaporator Fan On	Pass/Fail/Skip Result, Change in currents for Phase A, B and C
3-1	Low Speed Evaporator Fan Off	Pass/Fail/Skip Result, Change in currents for Phase A, B and C
4-0	High Speed Evaporator Fan On	Pass/Fail/Skip Result, Change in currents for Phase A, B and C
4-1	High Speed Evaporator Fan Off	Pass/Fail/Skip Result, Change in currents for Phase A, B and C
5-0	Supply/Return Probe Test	Pass/Fail/Skip Result, STS, RTS, SRS and RRS
5-1	Secondary Supply Probe (SRS) Test	Pass/Fail/Skip
5-2	Secondary Return Probe (RRS) Test	Pass/Fail/Skip
6-0	Discharge Thermistor Test	Pass/Fail/Skip
6-1	Suction Thermistor Test	Pass/Fail/Skip
6-2	Discharge Pressure Sensor Test	Pass/Fail/Skip
6-3	Suction Pressure Sensor Test	Pass/Fail/Skip
6-4	Compressor Current Draw Test	Pass/Fail/Skip
6-6	Economizer Valve Test	Pass/Fail/Skip
6-7	Digital Unloader Valve Test	Pass/Fail/Skip
7-0	High Pressure Switch Closed	Pass/Fail/Skip Result, AMBS, DPT or CPT (if equipped) Input values that component opens
7-1	High Pressure Switch Open	Pass/Fail/Skip Result, STS, DPT or CPT (if equipped) Input values that component closes
8-0	Perishable Mode Heat Test	Pass/Fail/Skip Result, STS, time it takes to heat to 16C (60F)
8-1	Perishable Mode Pulldown Test	Pass/Fail/Skip Result, STS, time it takes to pull down to 0C (32F)
8-2	Perishable Mode Maintain Test	Pass/Fail/Skip Result, Averaged DataCORDER supply temperature (SRS) over last recording interval.
9-0	Defrost Test	Pass/Fail/Skip Result, DTS reading at end of test, line voltage, line frequency, time in defrost.
10-0	Frozen Mode Heat Test	Pass/Fail/Skip Result, STS, time unit is in heat.
10-1	Frozen Mode Pulldown Test	Pass/Fail/Skip Result, STS, time to pull down unit to -17.8C (0F).
10-2	Frozen Mode Maintain Test	Pass/Fail/Skip Result, Averaged DataCORDER return temperature (RRS) over last recording interval.

Table 3-10 DataCORDER Alarm Indications

To Access: Press ALT. MODE key		
Code No.	TITLE	DESCRIPTION
dAL70	Recorder Supply Temperature Out of Range	The supply recorder sensor reading is outside of the range of -50C to 70C (-58F to +158F), or the probe check logic has determined there is a fault with this sensor. NOTE The P5 Pre-Trip test must be run to inactivate the alarm.
dAL71	Recorder Return Temperature Out of Range	The return recorder sensor reading is outside of the range of -50C to 70C (-58F to +158F), or the probe check logic has determined there is a fault with this sensor. NOTE The P5 Pre-Trip test must be run to inactivate the alarm.
dAL72-74	USDA Temperatures 1, 2, 3 Out of Range	The USDA probe temperature reading is outside of -50C to 70C (-58F to +158F) range.
dAL75	Cargo Probe 4 Out of Range	The cargo probe temperature reading is outside of -50C to 70C (-58F to +158F) range.
dAL76, 77	Future Expansion	These alarms are for future expansion and are not in use at this time.
dAL78-85	Network Data Point 1 - 8 Out of Range	The network data point is outside of its specified range. The DataCORDER is configured by default to record the supply and return recorder sensors. The DataCORDER may be configured to record up to eight additional network data points. An alarm number (AL78 to AL85) is assigned to each configured point. When an alarm occurs, the DataCORDER must be interrogated to identify the data point assigned. When a humidity sensor is installed, it is usually assigned to AL78.
dAL86	RTC Battery Low	The real time clock (RTC) backup battery is too low to adequately maintain the RTC reading.
dAL87	RTC Failure	An invalid date or time has been detected. This situation may be corrected by changing the real time clock (RTC) to a valid value using the DataView.
dAL88	DataCORDER EEPROM Failure	A write of critical DataCORDER information to the EEPROM has failed.
dAL89	Flash Memory Error	An error has been detected in the process of writing daily data to the non-volatile FLASH memory.
dAL90	Future Expansion	This alarm is for future expansion, and is not in use at this time.
dAL91	Alarm List Full	The DataCORDER alarm queue is determined to be full (eight alarms).

SECTION 4 OPERATION

4.1 INSPECTION (Before Starting)



WARNING

Beware of unannounced starting of the evaporator and condenser fans. The unit may cycle the fans and compressor unexpectedly as control requirements dictate.

- a. If container is empty, check inside for the following:
 1. Check channels or “T” bar floor for cleanliness. Channels must be free of debris for proper air circulation.
 2. Check container panels, insulation and door seals for damage. Effect permanent or temporary repairs.
 3. Visually check evaporator fan motor mounting bolts for proper securement (refer to paragraph 6.11).
 4. Check for dirt or grease on evaporator fans or fan deck and clean if necessary.
 5. Check evaporator coil for cleanliness or obstructions. Wash with fresh water.
 6. Check defrost drain pans and drain lines for obstructions and clear if necessary. Wash with fresh water.
 7. Check panels on refrigeration unit for loose bolts and condition of panels. Make sure TIR devices are in place on access panels.
- b. Check condenser coil for cleanliness. Wash with fresh water.
- c. Open control box door. Check for loose electrical connections or hardware.
- d. Check color of moisture-liquid indicator.

4.2 CONNECT POWER



WARNING

Do not attempt to remove power plug(s) before turning OFF start-stop switch (ST), unit circuit breaker(s) and external power source.



WARNING

Make sure the power plugs are clean and dry before connecting to power receptacle.

4.2.1 Connection To 380/460 VAC Power

1. Make sure start-stop switch (ST, on control panel) and circuit breaker (CB-1, in the control box) are in position “0” (OFF).

2. Plug the 460 VAC (yellow) cable into a de-energized 380/460 VAC, 3-phase power source. Energize the power source. Place circuit breaker (CB-1) in position “I” (ON). Close and secure control box door.

4.2.2 Connection To 190/230 VAC Power

An autotransformer (Figure 4-1) is required to allow operation on nominal 230 volt power. It is fitted with a 230 VAC cable and a receptacle to accept the standard 460 VAC power plug. The 230 volt cable is black in color while the 460 volt cable is yellow. The transformer may also be equipped with a circuit breaker (CB-2). The transformer is a step up transformer that will provide 380/460 VAC, 3-phase, 50/60 Hz power to the unit when the 230 VAC power cable is connected to a 190/230 VAC, 3-phase power source.

1. Make sure that the start-stop switch (ST, on control panel) and circuit breakers CB-1 (in the control box) and CB-2 (on the transformer) are in position “0” (OFF). Plug in and lock the 460 VAC power plug at the receptacle on the transformer.
2. Plug the 230 VAC (black) cable into a de-energized 190/230 VAC, 3-phase power source. Energize the power source. Set circuit breakers CB-1 and CB-2 to position “I” (ON). Close and secure control box door.

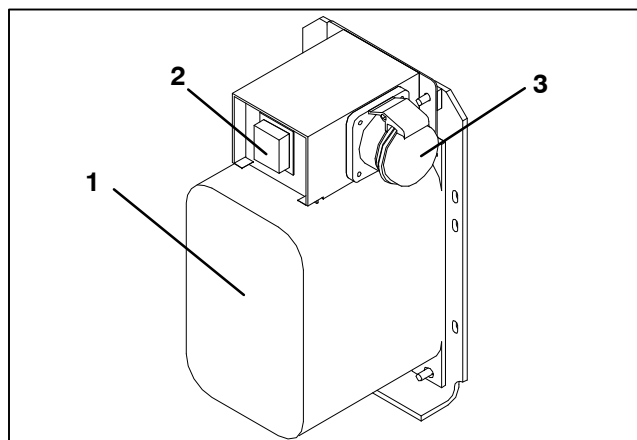

1. Dual Voltage Modular Autotransformer
2. Circuit Breaker (CB-2) 230-Volt
3. 460 VAC Power Receptacle

Figure 4-1 Autotransformer

4.3 ADJUST FRESH AIR MAKEUP VENT

The purpose of the fresh air makeup vent is to provide ventilation for commodities that require fresh air circulation. The vent *must be closed* when transporting frozen foods.

Air exchange depends on static pressure differential, which will vary depending on the container and how the container is loaded.

Units may be equipped with a vent position sensor (VPS). The VPS determines the position of the fresh air vent and sends data to the controller display.

4.3.1 Upper Fresh Air Makeup Vent

Two slots and a stop are designed into the Upper Fresh Air disc for air flow adjustments. The first slot allows for a 0 to 30% air flow; the second slot allows for a 30 to 100% air flow. To adjust the percentage of air flow, loosen the wing nut and rotate the disc until the desired percentage of air flow matches with the arrow. Tighten the wing nut. To clear the gap between the slots, loosen the wing nut until the disc clears the stop.

4.3.2 Lower Fresh Air Makeup Vent

a. Full Open or Closed Positions

Maximum air flow is achieved by loosening the wing nuts and moving the cover to the maximum open position (100% position). The closed position is 0% air flow position. The operator may also adjust the opening to increase or decrease the air flow volume to meet the required air flow.

b. Reduced Flow for Lower Fresh Air Makeup

NOTE

In order to prevent inaccurate display readings on units equipped with a Vent Position Sensor (VPS), ensure that the rack and pinion drive of the VPS is not disrupted when adjusting the air makeup vent.

NOTE

Do not loosen the hex nut beyond its stop. Doing so may cause inaccurate display readings and errors in DataCORDER reports.

Similar to the Upper Fresh Air Makeup vent, two slots and a stop are designed into the Lower Fresh Air slide for air flow adjustments. The first slot allows for a 0 to 25% air flow; the second slot allows for a 25 to 100% air flow. To adjust the percentage of air flow, loosen the hex nut and rotate the disc until the desired percentage of air flow matches with the arrow. Tighten the hex nut. To clear the gap between the slots, loosen the hex nut until the disc clears the stop.

On some models the air slide is supplied with two adjustable air control discs. The fresh air makeup can be adjusted for 15, 35, 50 or 75 cubic meters per hour (CMH). The air flow has been established at 60 Hz power and 2-1/2 inch T bar and with 15 mm (0.6 inch) H₂O external static above free blow.

Loosen the hex nut, adjust each disc to the required air flow, then tighten hex nut.

NOTE

The main air slide is in the fully closed position during reduced air flow operation when equipped with air control discs.

c. Air Sampling for Carbon Dioxide (CO₂) Level

Loosen hex nuts and move the cover until the arrow on the cover is aligned with the "atmosphere sampling port" label. Tighten the hex nuts and attach a 3/8 in. hose to the sampling port.

If the internal atmosphere content has reached an unacceptable level, the operator may adjust the disc opening to meet the required air flow volume to ventilate the container.

4.3.3 Vent Position Sensor

The VPS allows the user to determine the position of the fresh air vent via Function Code 45. This function code is accessible via the Code Select key.

The vent position will display for 30 seconds whenever motion corresponding to 5 CMH (3 CFM) or greater is detected. It will scroll in intervals of 5 CMH (3 CFM). Scrolling to Function Code 45 will display the Fresh Air Vent Position.

The position of the vent will be recorded in the DataCORDER whenever the unit is running under AC power and any of the following:

- Trip start
- On every power cycle
- Midnight
- Manual changes greater than 5 CMH (3 CFM) remaining in the new position for at least 4 minutes

NOTE

The user has four minutes to make necessary adjustments to the vent setting. This time calculation begins on the initial movement of the sensor. The vent can be moved to any position within the four minutes. On completion of the first four minutes, the vent is required to remain stable for the next four minutes. If vent position changes are detected during the four-minute stability period, an alarm will be generated. This provides the user with the ability to change the vent setting without generating multiple events in the DataCORDER.

4.4 CONNECT WATER-COOLED CONDENSER

The water-cooled condenser is used when cooling water is available and heating the surrounding air is objectionable, such as in a ship's hold. If water-cooled operation is desired, connect in accordance with the following subparagraphs.

4.4.1 Water-Cooled Condenser with Water Pressure Switch

- a. Connect the water supply line to the inlet side of condenser and the discharge line to the outlet side of the condenser. (See Figure 2-5.)
- b. Maintain a flow rate of 11 to 26 liters per minute (3 to 7 gallons per minute). The water pressure switch will open to de-energize the condenser fan relay. The condenser fan motor will stop and will remain stopped until the water pressure switch closes.
- c. To shift to air-cooled condenser operation, disconnect the water supply and the discharge line to the water-cooled condenser. The refrigeration unit will shift to air-cooled condenser operation when the water pressure switch closes.

4.4.2 Water-Cooled Condenser with Condenser Fan Switch

- a. Connect the water supply line to the inlet side of condenser and the discharge line to the outlet side of the condenser. (See Figure 2-5.)
- b. Maintain a flow rate of 11 to 26 lpm (3 to 7 gpm).
- c. Set the condenser fan switch to position "O." This will de-energize the condenser fan relay. The condenser fan motor will stop and remain stopped until the CFS switch is set to position "I."



CAUTION

When condenser water flow is below 11 lpm (3 gpm) or when water-cooled operation is not in use, the CFS switch **MUST** be set to position “1” or the unit will not operate properly.

- d. To shift to air-cooled condenser operation, stop the unit, set the CFS switch to position “1” and restart the unit. Disconnect the water lines to the water-cooled condenser.

4.5 CONNECT REMOTE MONITORING RECEPTACLE

If remote monitoring is required, connect remote monitor plug at unit receptacle. When the remote monitor plug is connected to the remote monitoring receptacle, the following remote circuits are energized:

CIRCUIT	FUNCTION
Sockets B to A	Energizes remote cool light
Sockets C to A	Energizes remote defrost light
Sockets D to A	Energizes remote in-range light

4.6 STARTING AND STOPPING INSTRUCTIONS



WARNING

Make sure that the unit circuit breaker(s) (CB-1 & CB-2) and the START-STOP switch (ST) are in the “O” (OFF) position before connecting to any electrical power source.

4.6.1 Starting the Unit

- a. With power properly applied, the fresh air vent position set and (if required) the water-cooled condenser connected (refer to paragraphs 4.2, 4.3 & 4.4), place the START-STOP switch to “1” (ON).

NOTE

The electronic phase detection system will check for proper compressor rotation within the first 30 seconds. If rotation is not correct, the compressor will be stopped and restarted in the opposite direction. If the compressor is producing unusually loud and continuous noise after the first 30 seconds of operation, stop the unit and investigate.

- b. The Controller Function Codes for the container ID (Cd40), software version (Cd18) and unit model number (Cd20) will be displayed in sequence.
- c. Continue with Start Up Inspection, paragraph 4.7.

4.6.2 Stopping the Unit

To stop the unit, place the START-STOP switch in position “0” (OFF).

4.7 START-UP INSPECTION

4.7.1 Physical Inspection

- a. Check rotation of condenser and evaporator fans.

4.7.2 Check Controller Function Codes

Check, and if required, reset controller Function Codes (Cd27 through Cd39) in accordance with desired operating parameters. Refer to Table 3-5.

4.7.3 Start Temperature Recorder

Partlow Recorders

- a. Open recorder door and check battery of electronic recorder. Be sure key is returned to storage clip of mechanical recorder.
- b. Lift stylus (pen) by pulling the marking tip outward until the stylus arm snaps into its retracted position.
- c. Install new chart, making sure chart is under the four corner tabs. Lower the stylus until it has made contact with the chart. Close and secure door.

DataCORDER

- a. Check and, if required, set the DataCORDER Configuration in accordance with desired recording parameter. Refer to paragraph 3.7.3.
- b. Enter a “Trip Start.” To enter a “Trip Start,” do the following:
 1. Depress the ALT MODE key. When the left display shows, dC, depress the ENTER key.
 2. Scroll to Code dC30.
 3. Depress and hold the ENTER key for five seconds.
 4. The “Trip Start” event will be entered in the DataCORDER.

4.7.4 Complete Inspection

Allow unit to run for five minutes to stabilize conditions and perform a pre-trip diagnosis in accordance with the following paragraph.

4.8 PRE-TRIP DIAGNOSIS



CAUTION

Pre-trip inspection should not be performed with critical temperature cargoes in the container.



CAUTION

When Pre-Trip key is pressed, economy, dehumidification and bulb mode will be deactivated. At the completion of Pre-Trip activity, economy, dehumidification and bulb mode must be reactivated.

Pre-Trip diagnosis provides automatic testing of the unit components using internal measurements and comparison logic. The program will provide a “PASS” or “FAIL” display to indicate test results.

The testing begins with access to a pre-trip selection menu. The user may have the option of selecting one of two automatic tests. These tests will automatically perform a series of individual pre-trip tests. The user may also scroll down to select any of the individual tests. When only the short sequence is configured, it will appear as “AUtO” in the display. Otherwise “AUtO1” will indicate the short sequence and “AUtO2” will indicate the long sequence. The test short sequence will run tests P0 through P6. The long test sequence will run tests P0 through P10.

A detailed description of the pre-trip test codes is listed in Table 3-7, page 3-23. If no selection is made, the pre-trip menu selection process will terminate automatically. However, dehumidification and bulb mode must be reactivated manually if required.

Scrolling down to the “rSLts” code and pressing ENTER will allow the user to scroll through the results of the last pre-trip testing run. If no pre-testing has been run (or an individual test has not been run) since the unit was powered up, “----” will be displayed.

To start a pre-trip test, do the following:

NOTE

1. Prior to starting tests, verify that unit voltage (Function Code Cd07) is within tolerance and unit amperage draw (Function Codes Cd04, Cd05, Cd06) are within expected limits. Otherwise, tests may fail incorrectly.
 2. All alarms must be rectified and cleared before starting tests.
 3. Pre-trip may also be initiated via communications. The operation is the same as for the keypad initiation described below except that should a test fail, the pre-trip mode will automatically terminate. When initiated via communications, a test may not be interrupted with an arrow key, but the pre-trip mode can be terminated with the PRE-TRIP key.
- a. Press the PRE-TRIP key. This accesses a test selection menu.
 - b. TO RUN AN AUTOMATIC TEST: Scroll through the selections by pressing the UP ARROW or DOWN ARROW keys to display AUTO, AUTO 1, AUTO 2 or AUTO 3 as desired, then press the ENTER key.
1. The unit will execute the series of tests without any need for direct user interface. These tests vary in length, depending on the component under test.
 2. While tests are running, “P#-#” will appear on the left display; the #'s indicate the test number and sub-test. The right display will show a countdown time in minutes and seconds, indicating the amount of time remaining in the test.

CAUTION

When a failure occurs during automatic testing, the unit will suspend operation awaiting operator intervention.

When an automatic test fails, it will be repeated once. A repeated test failure will cause “FAIL” to be shown on the right display, with the corresponding test number to the left. The user may then press the DOWN ARROW to repeat the test, the UP ARROW to skip to the next test or the PRE-TRIP key to terminate testing. The unit will wait indefinitely or until the user manually enters a command.

CAUTION

When Pre-Trip test Auto 2 runs to completion without being interrupted, the unit will terminate pre-trip and display “Auto 2” “end.” The unit will suspend operation until the user depresses the ENTER key!

When an Auto 1 runs to completion without a failure, the unit will exit the pre-trip mode and return to normal control operation. However, dehumidification and bulb mode must be reactivated manually if required.

- c. TO RUN AN INDIVIDUAL TEST: Scroll through the selections by pressing the UP ARROW or DOWN ARROW keys to display an individual test code. Pressing ENTER when the desired test code is displayed.
1. Individually selected tests, other than the LED/Display test, will perform the operations necessary to verify the operation of the component. At the conclusion, PASS or FAIL will be displayed. This message will remain displayed for up to three minutes, during which time a user may select another test. If the three minute time period expires, the unit will terminate pre-trip and return to control mode operation.
2. While the tests are being executed, the user may terminate the pre-trip diagnostics by pressing and holding the PRE-TRIP key. The unit will then resume normal operation. If the user decides to terminate a test but remain at the test selection menu, the user may press the UP ARROW key. When this is done, all test outputs will be de-energized and the test selection menu will be displayed.
3. Throughout the duration of any pre-trip test (except the P-7 high pressure switch tests), the current and pressure limiting processes are active. The current limiting process only is active for P-7.
- d. Pre-Trip Test Results

At the end of the pre-trip test selection menu, the message “P,” “rSLts” (pre-trip results) will be displayed. Pressing the ENTER key will allow the user to see the results for all subtests (i.e., 1-0, 1-1, etc). The results will be displayed as “PASS” or “FAIL” for all the tests run to completion since power up. If a test has not been run since power up, “----” will be displayed. Once all pre-test activity is completed, dehumidification and bulb mode must be reactivated manually if required.

4.9 OBSERVE UNIT OPERATION

4.9.1 Probe Check

If the DataCORDER is off or in alarm, the controller will revert to a four-probe configuration, which includes the DataCORDER supply and return air probes as the secondary controller probes. The controller continuously performs probe diagnosis testing that compares the four probes. If the probe diagnosis result indicates a probe problem exists, the controller will perform a probe check to identify the probe(s) in error.

a. Probe Diagnostic Logic - Standard

If the probe check option (controller configuration code CnF31) is configured for standard, the criteria used for comparison between the primary and secondary **control** probes is:

1C (1.8F) for perishable set points or 2C (3.6F) for frozen set points.

If 25 or more of 30 readings taken within a 30 minute period are outside of the limit, then a defrost is initiated and a probe check is performed.

In this configuration, a probe check will be run as a part of every normal (time initiated) defrost.

b. Probe Diagnostic Logic - Special

If the probe check option is configured for special, the above criteria are applicable. A defrost with probe check will be initiated if 25 of 30 readings or 10 consecutive readings are outside of the limits.

In this configuration, a probe check will not be run as part of a normal defrost, but only as part of a defrost initiated due to a diagnostic reading outside of the limits.

The 30-minute timer will be reset at each of the following conditions:

1. At every power up.
2. At the end of every defrost.
3. After every diagnostic check that does not fall outside of the limits as outlined above.

c. Probe Check

A defrost cycle probe check is accomplished by energizing just the evaporator motors for eight minutes at the end of the normal defrost. The probes will be compared to a set of predetermined limits at the end of the eight- minute period. The defrost indicator will remain on throughout this period.

Any probe(s) determined to be outside the limits will cause the appropriate alarm code(s) to be displayed to identify which probe(s) needs to be replaced. The P5 Pre-Trip test must be run to inactivate alarms.

SECTION 5 TROUBLESHOOTING

CONDITION	POSSIBLE CAUSE	REMEDY/ REFERENCE SECTION
5.1 UNIT WILL NOT START OR STARTS THEN STOPS		
No power to unit	External power source OFF	Turn on
	Start-Stop switch OFF or defective	Check
	Circuit breaker tripped or OFF	Check
	Autotransformer not connected	4.2.2
Loss of control power	Circuit breaker OFF or defective	Check
	Control transformer defective	Replace
	Fuse (F3A/F3B) blown	Check
	Start-Stop switch OFF or defective	Check
Component(s) not operating	Evaporator fan motor internal protector open	6.11
	Condenser fan motor internal protector open	6.7
	Compressor internal protector open	6.4
	High pressure switch open	5.8
	Heat termination thermostat open	Replace
	Malfunction of current sensor	Replace
Compressor hums, but does not start	Low line voltage	Check
	Single phasing	Check
	Shorted or grounded motor windings	6.4
	Compressor seized	6.4
5.2 UNIT OPERATES LONG OR CONTINUOUSLY IN COOLING		
Container	Hot load	Normal
	Defective box insulation or air leak	Repair
Refrigeration system	Shortage of refrigerant	6.3
	Evaporator coil covered with ice	5.6
	Evaporator coil plugged with debris	6.10
	Evaporator fan(s) rotating backwards	6.10/6.11
	Air bypass around evaporator coil	Check
	Controller set too low	Reset
	Compressor service valves or liquid line shutoff valve partially closed	Open valves completely
	Dirty condenser	6.6
	Compressor worn	6.4
	Current limit (function code Cd32) set to wrong value	3.4.3
	Economizer solenoid valve malfunction	6.16
	Digital unloader valve stuck open	Replace
	Electronic expansion valve	Replace

CONDITION	POSSIBLE CAUSE	REMEDY/ REFERENCE SECTION
5.3 UNIT RUNS BUT HAS INSUFFICIENT COOLING		
Refrigeration system	Abnormal pressures	5.8
	Abnormal temperatures	5.16
	Abnormal currents	5.17
	Controller malfunction	5.10
	Evaporator fan or motor defective	6.11
	Compressor service valves or liquid line shutoff valve partially closed	Open valves completely
	Frost on coil	5.11
	Digital unloader valve stuck open	Replace
	Electronic expansion valve	Replace
5.4 UNIT WILL NOT HEAT OR HAS INSUFFICIENT HEATING		
No operation of any kind	Start-Stop switch OFF or defective	Check
	Circuit breaker OFF or defective	Check
	External power source OFF	Turn ON
No control power	Circuit breaker or fuse defective	Replace
	Control Transformer defective	Replace
	Evaporator fan internal motor protector open	6.11
	Heat relay defective	Check
	Heater termination thermostat open	6.10
Unit will not heat or has insufficient heat	Heater(s) defective	6.10
	Heater contactor or coil defective	Replace
	Evaporator fan motor(s) defective or rotating backwards	6.10/6.11
	Evaporator fan motor contactor defective	Replace
	Controller malfunction	5.10
	Defective wiring	Replace
	Loose terminal connections	Tighten
	Low line voltage	2.3
5.5 UNIT WILL NOT TERMINATE HEATING		
Unit fails to stop heating	Controller improperly set	Reset
	Controller malfunction	5.10
	Heater termination thermostat remains closed along with the heat relay	6.10
5.6 UNIT WILL NOT DEFROST PROPERLY		
Will not initiate defrost automatically	Defrost timer malfunction (Cd27)	Table 3-5
	Loose terminal connections	Tighten
	Defective wiring	Replace
	Defrost temperature sensor defective or heat termination thermostat open	Replace
	Heater contactor or coil defective	Replace
Will not initiate defrost manually	Manual defrost switch defective	Replace
	Keypad is defective	Replace
	Defrost temperature sensor open	Replace
Initiates but relay (DR) drops out	Low line voltage	2.3

CONDITION	POSSIBLE CAUSE	REMEDY/ REFERENCE SECTION
5.7 UNIT WILL NOT DEFROST PROPERLY (Continued)		
Initiates but does not defrost	Heater contactor or coil defective	Replace
	Heater(s) burned out	6.10
Frequent defrost	Wet load	Normal
5.8 ABNORMAL PRESSURES (COOLING)		
High discharge pressure	Condenser coil dirty	6.6
	Condenser fan rotating backwards	6.7
	Condenser fan inoperative	6.7
	Refrigerant overcharge or noncondensibles	6.3
	Discharge service valve partially closed	Open
	Electronic expansion valve (EEV) control malfunction	Replace
Low suction pressure	Incorrect software and/or controller configuration	Check
	Failed suction pressure transducer	Replace
	Suction service valve partially closed	Open
	Filter drier partially plugged	6.9
	Low refrigerant charge	6.3
	No evaporator air flow or restricted air flow	6.10
	Excessive frost on evaporator coil	5.6
	Evaporator fan(s) rotating backwards	6.11.3
	EEV control malfunction	Replace
Failed digital unloader valve (DUV)	Replace	
Suction and discharge pressures tend to equalize when unit is operating	Compressor operating in reverse	5.15
	Compressor cycling/stopped	Check
	Failed digital unloader valve (DUV)	Replace
5.9 ABNORMAL NOISE OR VIBRATIONS		
Compressor	Compressor start up after an extended shutdown	Normal
	Brief chattering when manually shut down	
	Compressor operating in reverse	5.15
	Loose mounting bolts or worn resilient mounts	Tighten/Replace
	Loose upper mounting	6.4.1
	Liquid slugging	6.12
Condenser or Evaporator Fan	Bent, loose or striking venturi	Check
	Worn motor bearings	6.7/6.11
	Bent motor shaft	6.7/6.11
5.10 MICROPROCESSOR MALFUNCTION		
Will not control	Incorrect software and/or controller configuration	Check
	Defective sensor	6.20
	Defective wiring	Check
	Low refrigerant charge	6.3

CONDITION	POSSIBLE CAUSE	REMEDY/ REFERENCE SECTION
5.11 NO EVAPORATOR AIR FLOW OR RESTRICTED AIR FLOW		
Evaporator coil blocked	Frost on coil	5.6
	Dirty coil	6.10
No or partial evaporator air flow	Evaporator fan motor internal protector open	6.11
	Evaporator fan motor(s) defective	6.11
	Evaporator fan(s) loose or defective	6.11
	Evaporator fan contactor defective	Replace
5.12 ELECTRONIC EXPANSION VALVE MALFUNCTION		
Low suction pressure	Incorrect software and/or controller configuration	Check
	Failed suction pressure transducer	Replace
	Suction service valve partially closed	Open
	Filter drier partially plugged	6.9
	Low refrigerant charge	6.3
	No evaporator air flow or restricted air flow	6.10
	Excessive frost on evaporator coil	5.6
	Evaporator fan(s) rotating backwards	6.11.3
	EEV control malfunction	6.12
	Failed digital unloader valve (DUV)	Replace
	Loose or insufficiently clamped sensor	Replace
High suction pressure with low superheat	Foreign material in valve	6.12
	Failed suction pressure transducer (SPT)	Replace
	EEV control malfunction	Replace
	Improperly seated powerhead	Ensure power-head is locked and in place
Liquid slugging in compressor	Failed suction pressure transducer (SPT)	Replace
	Failed EEV	Replace
5.13 AUTOTRANSFORMER MALFUNCTION		
Unit will not start	Circuit breaker (CB-1 or CB-2) tripped	Check
	Autotransformer defective	6.17
	Power source not turned ON	Check
	460 VAC power plug is not inserted into the receptacle	4.2.2
5.14 WATER-COOLED CONDENSER OR WATER PRESSURE SWITCH		
High discharge pressure	Dirty coil	6.8
	Noncondensibles	
Condenser fan starts and stops	Water pressure switch malfunction	Check
	Water supply interruption	Check

CONDITION	POSSIBLE CAUSE	REMEDY/ REFERENCE SECTION
<p>5.15 COMPRESSOR OPERATING IN REVERSE</p> <p style="text-align: center;">NOTE</p> <p>The compressor may start in reverse for up to 10 seconds to determine correct phase rotation if required for phase detection.</p>		
<p style="text-align: center;">CAUTION</p> <p>Allowing the scroll compressor to operate in reverse for more than two minutes will result in internal compressor damage. Turn the start-stop switch OFF immediately.</p>		
Electrical	Incorrect wiring of compressor	Check
	Incorrect wiring of compressor contactor(s)	
	Incorrect wiring of current sensor	
<p>5.16 ABNORMAL TEMPERATURES</p>		
High discharge temperature	Discharge temperature sensor drifting high	Replace
	Failed economizer expansion valve, economizer coil, or economizer solenoid valve	Replace
	Plugged economizer expansion valve, economizer coil, or economizer solenoid valve	Replace
	Liquid injection valve failure	Replace
	Loose or insufficiently clamped sensor	Replace
<p>5.17 ABNORMAL CURRENTS</p>		
Unit reads abnormal currents	Current sensor wiring	Check

SECTION 6

SERVICE

NOTE

Use a refrigerant recovery system whenever removing refrigerant. When working with refrigerants you must comply with all local government environmental laws. In the U.S.A., refer to EPA section 608.

DANGER

Never use air for leak testing. It has been determined that pressurized, mixtures of refrigerant and air can undergo combustion when exposed to an ignition source.

6.1 SECTION LAYOUT

Service procedures are provided herein beginning with refrigeration system service, then refrigeration system component service, electrical system service, temperature recorder service and general service. Refer to the Table of Contents to locate specific topics.

6.2 MANIFOLD GAUGE SET

The manifold gauge set (see Figure 6-1) is used to determine system operating pressure, add refrigerant charge, and to equalize or evacuate the system.

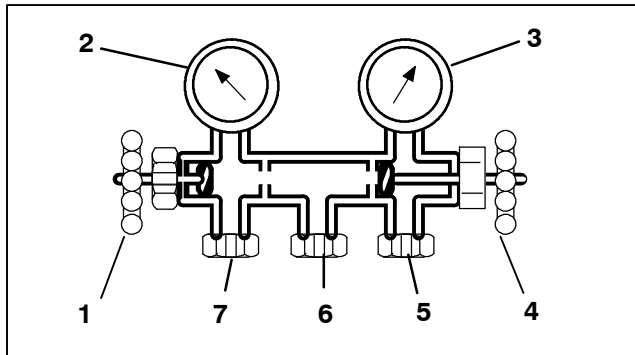

1. Opened (Backseated) Hand Valve
2. Suction Pressure Gauge
3. Discharge Pressure Gauge
4. Closed (Frontseated) Hand Valve
5. Connection to high side of system
6. Connection to either:
 - a. Refrigerant cylinder OR
 - b. Oil Container
7. Connection to low side of system

Figure 6-1 Manifold Gauge Set

When the suction pressure hand valve is frontseated (turned all the way in), the suction (low) pressure can be checked. When the discharge pressure hand valve is frontseated, the discharge (high) pressure can be checked. When both valves are open (all the way out), high pressure vapor will flow into the low side. When the suction pressure valve is open and the discharge pressure valve shut, the system can be charged. Oil can also be added to the system.

A R-134a manifold gauge/hose set with self-sealing hoses (see Figure 6-2) is required for service of the models covered within this manual. The manifold gauge/hose set is available from Carrier Transicold. (Carrier Transicold part number 07-00294-00, which includes items 1 through 6, Figure 6-2.) To perform service using the manifold gauge/hose set, do the following:

a. Preparing Manifold Gauge/Hose Set For Use

If the manifold gauge/hose set is new or was exposed to the atmosphere, it will need to be evacuated to remove contaminants and air as follows:

1. Back seat (turn counterclockwise) both field service couplings (see Figure 6-2) and midseat both hand valves.
2. Connect the yellow hose to a vacuum pump and refrigerant 134a cylinder.

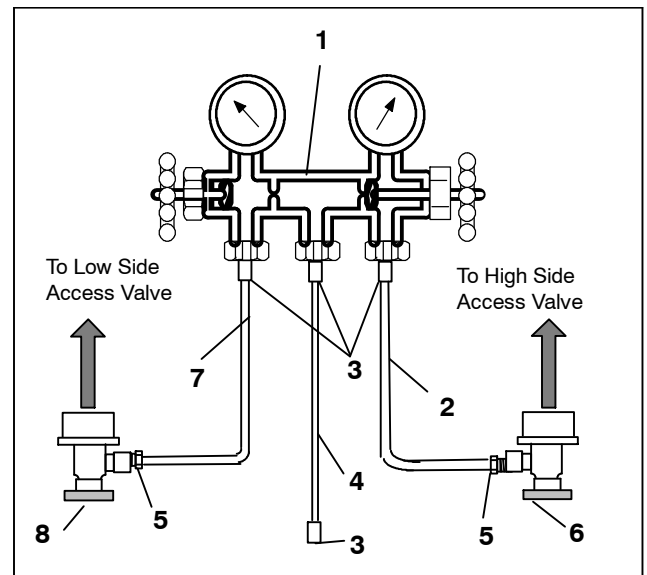

1. Manifold Gauge Set
2. RED Refrigeration and/or Evacuation Hose (SAE J2196/R-134a)
3. Hose Fitting (0.5-16 Acme)
4. YELLOW Refrigeration and/or Evacuation Hose (SAE J2196/R-134a)
5. Hose Fitting with O-ring (M14 x 1.5)
6. High Side Field Service Coupling (Red Knob)
7. BLUE Refrigeration and/or Evacuation Hose (SAE J2196/R-134a)
8. Low Side Field Service Coupling (Blue Knob)

Figure 6-2 R-134a Manifold Gauge/Hose Set

3. Evacuate to 10 inches of vacuum and then charge with R-134a to a slightly positive pressure of 0.1 kg/cm² (1.0 psig).
4. Front seat both manifold gauge set valves and disconnect from cylinder. The gauge set is now ready for use.

6.3 REFRIGERATION SYSTEM SERVICE-UNITS WITH STANDARD PIPING (with Service Valves)

6.3.1 Service Connections

The compressor suction, compressor discharge, and the liquid line service valves (see Figure 6-3) are provided with a double seat and an access valve which enable servicing of the compressor and refrigerant lines. Turning the valve stem clockwise (all the way forward) will frontseat the valve to close off the line connection and open a path to the access valve. Turning the stem counterclockwise (all the way out) will backseat the valve to open the line connection and close off the path to the access valve.

With the valve stem midway between frontseat and backseat, both of the service valve connections are open to the access valve path.

For example, the valve stem is first fully backseated when connecting a manifold gauge to measure pressure. Then, the valve is opened 1/4 to 1/2 turn to measure the pressure.

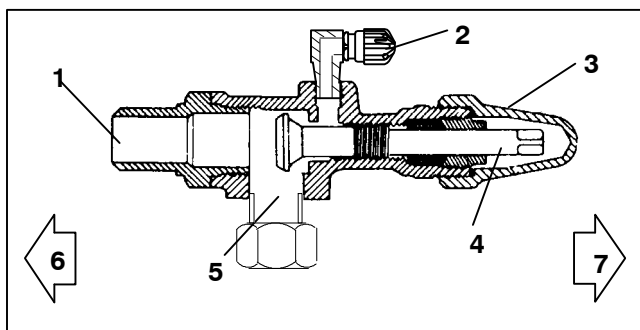

- | | |
|--------------------|--|
| 1. Line Connection | 5. Compressor Or Filter Drier Inlet Connection |
| 2. Access Valve | 6. Valve (Frontseated) |
| 3. Stem Cap | 7. Valve (Backseated) |
| 4. Valve stem | |

Figure 6-3 Service Valve

To connect the manifold gauge/hose set for reading pressures, do the following:

1. Remove service valve stem cap and check to make sure it is backseated. Remove access valve cap. (See Figure 6-3).
2. Connect the field service coupling (see Figure 6-2) to the access valve.
3. Turn the field service coupling knob clockwise, which will open the system to the gauge set.
4. To read system pressures, slightly midseat the service valve.
5. Repeat the procedure to connect the other side of the gauge set.



To prevent trapping liquid refrigerant in the manifold gauge set be sure set is brought to suction pressure before disconnecting.

- a. Removing the Manifold Gauge Set
 1. While the compressor is still ON, backseat the high side service valve.
 2. Midseat both hand valves on the manifold gauge set and allow the pressure in the manifold gauge set to be drawn down to low side pressure. This returns any liquid that may be in the high side hose to the system.
 3. Backseat the low side service valve. Backseat both field service couplings and frontseat both manifold hand valves. Remove the couplings from the access valves.
 4. Install both service valve stem caps and service port caps (finger-tight only).

6.3.2 Pumping Down the Unit

To service the filter drier, economizer, expansion valves, economizer solenoid valve, liquid injection valve, digital unloader valve or evaporator coil, pump the refrigerant into the high side as follows:



The scroll compressor achieves low suction pressure very quickly. Do not operate the compressor in a deep vacuum, internal damage will result.

- a. Attach manifold gauge set to the compressor suction and discharge service valves. Refer to paragraph 6.2.
- b. Start the unit and run in the frozen mode (controller set below -10C (14F) for 10 to 15 minutes.
- c. Check function code Cd21 (refer to paragraph 3.2.2). The economizer solenoid valve should be open. If not, continue to run until the valve opens.
- d. Frontseat the liquid line service valve. Place start-stop switch in the OFF position when the suction reaches a positive pressure of 0.1 bar (1.4 psig).
- e. Frontseat the suction and discharge service valves. The refrigerant will be trapped between the compressor discharge service valves and the liquid line valve.
- f. Before opening up any part of the system, a slight positive pressure should be indicated on the pressure gauge. If a vacuum is indicated, emit refrigerant by cracking the liquid line valve momentarily to build up a slight positive pressure.
- g. When opening up the refrigerant system, certain parts may frost. Allow the part to warm to ambient temperature before dismantling. This avoids internal condensation which puts moisture in the system.
- h. After repairs have been made, be sure to perform a refrigerant leak check (refer to paragraph 6.3.3), and evacuate and dehydrate the low side (refer to paragraph 6.3.4).
- i. Check refrigerant charge (refer to paragraph 6.3.5).

6.3.3 Refrigerant Leak Checking

WARNING

Never use air for leak testing. It has been determined that pressurized, air-rich mixtures of refrigerants and air can undergo combustion when exposed to an ignition source.

- The recommended procedure for finding leaks in a system is with a R-134a electronic leak detector. Testing joints with soapsuds is satisfactory only for locating large leaks.
- If the system is without refrigerant, charge the system with refrigerant 134a to build up pressure between 2.1 to 3.5 bar (30.5 to 50.8 psig). To ensure complete pressurization of the system, refrigerant should be charged at the compressor suction valve and the liquid line service valve. Remove refrigerant cylinder and leak-check all connections.

NOTE

Only refrigerant 134a should be used to pressurize the system. Any other gas or vapor will contaminate the system, which will require additional purging and evacuation of the system.

- If required, remove refrigerant using a refrigerant recovery system and repair any leaks. Check for leaks.
- Evacuate and dehydrate the unit. (Refer to paragraph 6.3.4.)
- Charge unit per paragraph 6.3.5.

6.3.4 Evacuation and Dehydration

General

Moisture is detrimental to refrigeration systems. The presence of moisture in a refrigeration system can have many undesirable effects. The most common are copper plating, acid sludge formation, "freezing-up" of metering devices by free water, and formation of acids, resulting in metal corrosion.

Preparation

- Evacuate and dehydrate only after pressure leak test.
- Essential tools to properly evacuate and dehydrate any system include a vacuum pump (8 m³/hr = 5 cfm volume displacement) and an electronic vacuum gauge. (The pump is available from Carrier Transicold, part number 07-00176-11.)
- If possible, keep the ambient temperature above 15.6C (60F) to speed evaporation of moisture. If the ambient temperature is lower than 15.6C (60F), ice might form before moisture removal is complete. Heat lamps or alternate sources of heat may be used to raise the system temperature.
- Additional time may be saved during a complete system pump down by replacing the filter drier with a section of copper tubing and the appropriate fittings. Installation of a new drier may be performed during the charging procedure.

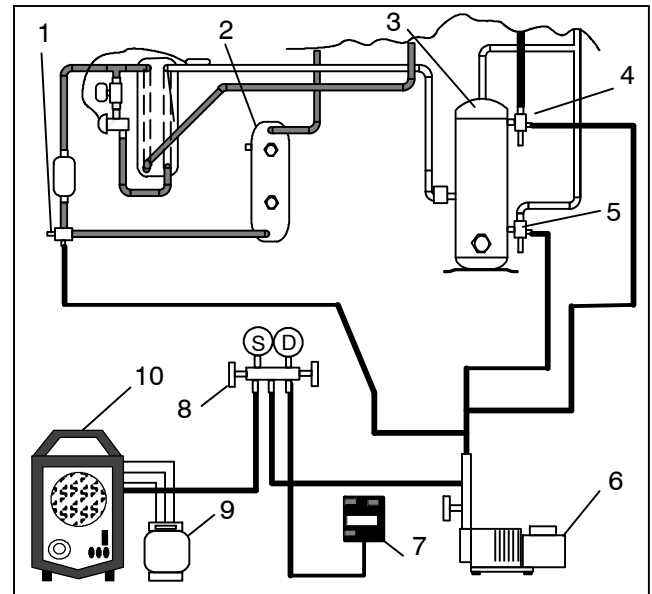

- | | |
|---------------------------------------|-------------------------------|
| 1. Liquid Service Connection | 5. Suction Service Connection |
| 2. Receiver or Water Cooled Condenser | 6. Vacuum Pump |
| 3. Compressor | 7. Electronic Vacuum Gauge |
| 4. Discharge Service Connection | 8. Manifold Gauge Set |
| | 9. Refrigerant Cylinder |
| | 10. Reclaimer |

Figure 6-4 Refrigeration System Service Connections

Procedure - Complete System

NOTE

Refer to Partial System procedure for information pertaining to partial system evacuation and dehydration.

- Remove all refrigerant using a refrigerant recovery system.
- The recommended method to evacuate and dehydrate the system is to connect evacuation hoses at the compressor suction and liquid line service valve (see Figure 6-4). Be sure the service hoses are suited for evacuation purposes.
- Test the evacuation setup for leaks by backseating the unit service valves and drawing a deep vacuum with the vacuum pump and gauge valves open. Shut off the pump and check to see if the vacuum holds. Repair leaks if necessary.
- Midseat the refrigerant system service valves.
- Open the vacuum pump and electronic vacuum gauge valves, if they are not already open. Start the vacuum pump. Evacuate unit until the electronic vacuum gauge indicates 2000 microns. Close the electronic vacuum gauge and vacuum pump valves. Shut off the vacuum pump. Wait a few minutes to be sure the vacuum holds.
- Break the vacuum with clean dry refrigerant 134a gas. Raise system pressure to roughly 0.14 bar (2 psig), monitoring it with the compound gauge.
- Remove refrigerant using a refrigerant recovery system.

- h. Repeat steps e. and f. one time.
- i. Remove the copper tubing and change the filter drier. Evacuate unit to 500 microns. Close the electronic vacuum gauge and vacuum pump valves. Shut off the vacuum pump. Wait five minutes to see if vacuum holds. This procedure checks for residual moisture and/or leaks.
- j. With a vacuum still in the unit, the refrigerant charge may be drawn into the system from a refrigerant container on weight scales.

Procedure - Partial System

- a. If refrigerant charge has been removed from the low side only, evacuate the low side by connecting the evacuation set-up at the compressor suction valve and the liquid service valve but leave the service valves frontseated until evacuation is completed.
- b. Once evacuation has been completed and the pump has been isolated, fully backseat the service valves to isolate the service connections and then continue with checking and, if required, adding refrigerant in accordance with normal procedures.

6.3.5 Refrigerant Charge

Checking the Refrigerant Charge

NOTE

Use a refrigerant recovery system whenever removing refrigerant. When working with refrigerants you must comply with all local government environmental laws. In the U.S.A., refer to EPA Section 608.

- a. Connect the gauge manifold to the compressor discharge and suction service valves. For units operating on a water cooled condenser, change over to air cooled operation.
- b. Bring the container temperature to approximately 0C (32F) or below. Then set the controller set point to -25C (-13F).
- c. Partially block the condenser coil inlet air. Increase the area blocked until the compressor discharge pressure is raised to approximately 12.8 bar (185 psig).
- d. On units equipped with a receiver, the level should be between the glasses. On units equipped with a water-cooled condenser, the level should be at the center of the glass. If the refrigerant level is not correct, continue with the following paragraphs to add or remove refrigerant as required.

Adding Refrigerant to System (Full Charge)

- a. Evacuate unit and leave in deep vacuum. (Refer to paragraph 6.3.4.)
- b. Place cylinder of R-134a on scale and connect charging line from cylinder to liquid line valve. Purge charging line at liquid line valve and then note weight of cylinder and refrigerant.
- c. Open liquid valve on cylinder. Open liquid line valve half-way and allow the liquid refrigerant to flow into the unit until the correct weight of refrigerant (refer to paragraph 2.2) has been added as indicated by scales.

NOTE

It may be necessary to finish charging unit through suction service valve in gas form, due to pressure rise in high side of the system.

- d. Backseat manual liquid line valve (to close off gauge port). Close liquid valve on cylinder.
- e. Start unit in cooling mode. Run for approximately 10 minutes and check the refrigerant charge.

Adding Refrigerant to System (Partial Charge)

- a. Examine the unit refrigerant system for any evidence of leaks. Repair as necessary. (Refer to paragraph 6.3.3.)
- b. Maintain the conditions outlined in paragraph 6.3.5.
- c. Fully backseat the suction service valve and remove the service port cap.
- d. Connect charging line between suction service valve port and cylinder of refrigerant R-134a. Open VAPOR valve.
- e. Partially frontseat (turn clockwise) the suction service valve and slowly add charge until the refrigerant appears at the proper level. Be careful not to frontseat the suction valve fully, if the compressor is operated in a vacuum, internal damage may result.

6.4 COMPRESSOR



WARNING

Make sure power to the unit is OFF and power plug disconnected before replacing the compressor.



WARNING

Before disassembly of the compressor, be sure to relieve the internal pressure very carefully by slightly loosening the couplings to break the seal.



CAUTION

The scroll compressor achieves low suction pressure very quickly. Do not use the compressor to evacuate the system below 0 psig. Never operate the compressor with the suction or discharge service valves closed (frontseated). Internal damage will result from operating the compressor in a deep vacuum.

6.4.1 Removal and Replacement of Compressor

- a. Turn the unit ON and run it in full cool mode for 10 minutes.

NOTE

If the compressor is not operational, front-seat the suction and discharge service valves and go to step f. below.

- b. Frontseat the manual liquid line valve and allow the unit to pull-down to 0.1 kg/cm² (1 psig).
- c. Turn the unit start-stop switch (ST) and unit circuit breaker (CB-1) OFF, and disconnect power to the unit.
- d. Frontseat the discharge and suction service valves.
- e. Remove all remaining refrigerant from the compressor using a refrigerant recovery system.
- f. Remove the compressor terminal cover, disconnect the ground wire and pull the cable plug from the compressor terminals. Install the terminal cover back after removing the power cable.

NOTE

Inspect the power cable (plug) terminals to ensure they are not deformed or have any signs of heat or arcing. If any damage is noted, replace the power cable.

- g. Remove the Rotalock fittings from the suction and discharge service connections, and uncouple the unloader and economizer lines from the compressor.
- h. Cut the dome temperature sensor wires. The replacement compressor comes with a dome temperature sensor already assembled.
- i. Remove and save the compressor base-mounting bolts. Discard the 4 top resilient mounts and washers.
- j. Remove (slide out) the old compressor from the unit.
- k. Inspect compressor base plate for wear. Replace, if necessary.
- l. Wire tie the compressor base plate to the compressor, and slide the new compressor into the unit. Refer to Figure 6-5.

NOTE

DO NOT add any oil to the replacement compressor. Replacement compressor is shipped with full oil charge of 60 oz.

- m. Cut and discard the wire ties used to hold the base plate to the compressor.
- n. Place the new SST washers on each side of the resilient mounts, and the new Mylar washer on the bottom of it as shown in Figure 6-5. Install the four base-mounting screws loosely.
- o. Place the new Teflon seals at the compressor suction and discharge ports as well as the O-rings at the unloader and economizer line connection ports. Hand tighten all four connections.
- p. Torque the four base-mounting screws to 6.2 mkg (45 ft-lbs.).

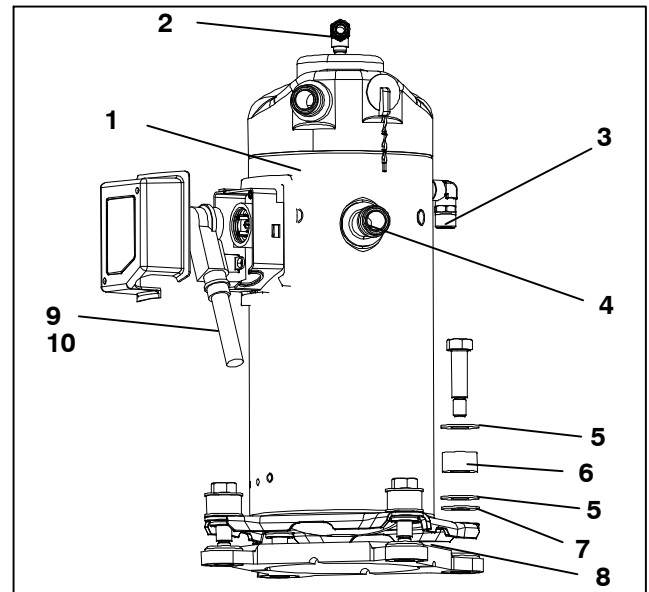

- | | |
|-------------------------------------|--|
| 1. Compressor | 6. Resilient Mount |
| 2. O-Ring (Unloader Connection) | 7. Mylar Washers |
| 3. O-Ring (Economizer Connection) | 8. Wire Ties |
| 4. Teflon Seal for Valve Connection | 9. Power Cable Gasket Screw |
| 5. SST Washers | 10. Ground Connection |
| | 11. Power Cable Lubricant - Krytox (Not Shown) |

Figure 6-5 Compressor Kit

- q. Torque the compressor ports / connections to:

Service Valve / Connection	Torque Value
Suction and Discharge Rotalocks	108.5 to 135.5 Nm (80 to 100 ft-lbs.)
Unloader connection	24.5 to 27 Nm (18 to 20 ft-lbs.)
Economized connection	32.5 to 35 Nm (24 to 26 ft-lbs.)

- r. Connect (butt-splice and heat shrink) the new compressor dome temperature sensor with the old sensor wires removed in step 9. Wire-tie any loose wiring as appropriate.
- s. Evacuate the compressor to 1000 microns if the unit was pumped down before the replaced compressor was removed. Otherwise, evacuate the complete unit and charge it with R-134a refrigerant (see Sections 6.3.4 and 6.3.5).
- t. Open the compressor terminal cover and connect the compressor power cable following the steps below:
- u. Liberally coat the orange gasket surfaces with the Krytox lubricant.
- v. Install the orange gasket part onto the compressor fusite with the grooved or threaded side out. Ensure that the gasket is seated onto the fusite base.
- w. Coat the inside of the power plug (female) connector pins with the Krytox lubricant, and insert the plug onto the compressor terminal connections. Make sure, the orange gasket has bottomed out onto the

fusite and it fits securely onto the terminal pins while fully inserted into the orange plug.

- x. Connect the green ground wire to the grounding tab located inside the terminal box of the compressor using the self-tapping grounding screw. Close the compressor terminal box using the terminal cover removed in step 20 above.
- y. Backseat all service valves, connect the power to the unit and run it for at least 20 minutes.
- z. Perform a leak check of the system.

6.5 HIGH PRESSURE SWITCH

6.5.1 Replacing High Pressure Switch

- a. Remove the refrigerant charge.
- b. Disconnect wiring from defective switch. The high pressure switch is located on the discharge connection or line and is removed by turning counterclockwise.
- c. Install a new high pressure switch after verifying switch settings.
- d. Evacuate, dehydrate and recharge.
- e. Start unit, verify refrigeration charge and oil level.

6.5.2 Checking High Pressure Switch



WARNING

Do not use a nitrogen cylinder without a pressure regulator. Do not use oxygen in or near a refrigeration system as an explosion may occur.

NOTE

The high pressure switch is non-adjustable.

- a. Remove switch as outlined in paragraph 6.5.1.
- b. Connect ohmmeter or continuity light across switch terminals. Ohm meter will indicate no resistance or continuity light will be illuminated if the switch closed after relieving compressor pressure.
- c. Connect hose to a cylinder of dry nitrogen. (See Figure 6-6.

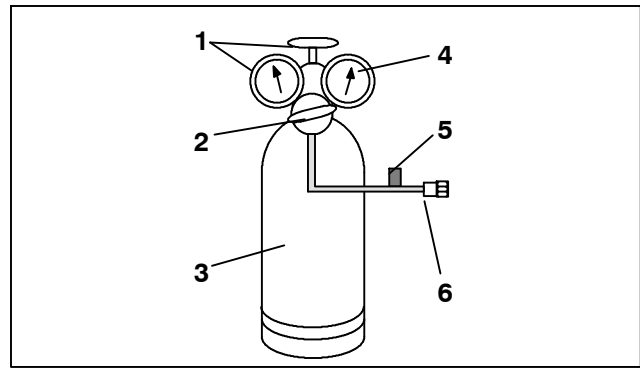

- | | |
|-----------------------------|--|
| 1. Cylinder Valve and Gauge | 4. Pressure Gauge (0 to 36 kg/cm ² = 0 to 400 psig) |
| 2. Pressure Regulator | 5. Bleed-Off Valve |
| 3. Nitrogen Cylinder | 6. 1/4 inch Connection |

Figure 6-6 High Pressure Switch Testing

- d. Set nitrogen pressure regulator at 26.4 kg/cm² (375 psig) with bleed-off valve closed.
- e. Close valve on cylinder and open bleed-off valve.
- f. Open cylinder valve. Slowly close bleed-off valve to increase pressure on switch. The switch should open at a static pressure up to 25 kg/cm² (350 psig). If a light is used, light will go out. If an ohmmeter is used, the meter will indicate open circuit.
- g. Slowly open bleed-off valve to decrease the pressure. The switch should close at 18 kg/cm² (250 psig).

6.6 CONDENSER COIL

The condenser consists of a series of parallel copper tubes expanded into copper fins. The condenser coil must be cleaned with fresh water or steam so the air flow is not restricted. To replace the coil, do the following:



WARNING

Do not open the condenser fan grille before turning power OFF and disconnecting power plug.

- a. Using a refrigerant reclaim system, remove the refrigerant charge.
- b. Remove the condenser coil guard.
- c. Unsolder discharge line and remove the line to the receiver or water-cooled condenser.
- d. Remove coil mounting hardware and remove the coil.
- e. Install replacement coil and solder connections.
- f. Leak-check the coil connections per paragraph 6.3.3. Evacuate the unit then charge the unit with refrigerant.

6.7 CONDENSER FAN AND MOTOR ASSEMBLY

WARNING

Do not open condenser fan grille before turning power OFF and disconnecting power plug.

The condenser fan rotates counter-clockwise (viewed from front of unit), pulls air through the the condenser coil, and discharges horizontally through the front of the unit. To replace motor assembly:

- Open condenser fan screen guard.
- Loosen two square head set screws on fan. (Thread sealer has been applied to set screws at installation.)
- Disconnect wiring connector.

CAUTION

Take necessary steps (place plywood over coil or use sling on motor) to prevent motor from falling into condenser coil.

- Remove motor mounting hardware and replace the motor. It is recommended that new locknuts be used when replacing motor.
- Connect the wiring connector.
- Install fan loosely on motor shaft (hub side in). DO NOT USE FORCE. If necessary, tap the hub only, not the hub nuts or bolts. Install venturi. Apply "Loctite H" to fan set screws. Adjust fan within venturi so that the outer edge of the fan is within 2.0 +/- 0.07 mm (0.08" +/- 0.03") from the outside of the orifice opening. Spin fan by hand to check clearance.
- Close and secure condenser fan screen guard.

6.8 WATER-COOLED CONDENSER CLEANING

The water-cooled condenser is of the shell and coil type with water circulating through the cupro-nickel coil. The refrigerant vapor is admitted to the shell side and is condensed on the outer surface of the coil.

Rust, scale and slime on the water-cooling surfaces inside of the coil interfere with the transfer of heat, reduce system capacity, cause higher head pressures and increase the load on the system.

By checking the leaving water temperature and the actual condensing temperature, it can be determined if the condenser coil is becoming dirty. A larger than normal difference between leaving condensing water temperature and actual condensing temperature, coupled with a small difference in temperature of entering and leaving condensing water, is an indication of a dirty condensing coil.

To find the approximate condensing temperature, with the unit running in the cooling mode, install a gauge 0 to 36.2 kg/cm² (0 to 500 psig) on the compressor discharge service valve.

Example: Discharge pressure is 10.3 kg/cm² (146.4 psig). Referring to Table 6-4 (R-134a pressure/temperature chart), the 10.3 kg/cm² (146.4 psig) value converts to 43C (110F).

If the water-cooled condenser is dirty, it may be cleaned and de-scaled by the following procedure:

- Turn unit off and disconnect main power.
- Disconnect water pressure switch tubing by loosening the two flare nuts. Install one-quarter inch flare cap on water-cooled condenser inlet tube (replaces tubing flare nut). De-scale tubing if necessary.

What You Will Need:

- Oakite Composition No. 22, available as a powder in 68 kg (150 lb) and 136 kg (300 lb) containers.
- Oakite Composition No. 32, available as a liquid in cases, each containing 3.785 liters (4 U.S. gallon) bottles and also in carboys of 52.6 kg (116 lbs) net.
- Fresh clean water.
- Acid proof pump and containers or bottles with rubber hose.

NOTE

When Oakite Compound No. 32 is used for the first time, the local Oakite Technical Service representative should be called in for suggestions in planning the procedure. The representative will advise the reader on how to do the work with a minimum dismantling of equipment: how to estimate the time and amount of compound required; how to prepare the solution; how to control and conclude the de-scaling operation by rinsing and neutralizing equipment before putting it back into service. The representative's knowledge of metals, types of scale, water conditions and de-scaling techniques will be highly useful.

Summary of Procedure:

- Drain water from condenser tubing circuit.
- Clean water tubes with Oakite No. 22 to remove mud and slime.
- Flush.
- De-scale water tubes with Oakite No. 32 to remove scale.
- Flush.
- Neutralize.
- Flush.
- Put unit back in service under normal load and check head (discharge) pressure.

Detailed Procedure:

- Drain and flush the water circuit of the condenser coil. If scale on the tube inner surfaces is accompanied by slime, a thorough cleaning is necessary before de-scaling process can be accomplished.
- To remove slime or mud, use Oakite Composition No. 22. Mixed 170 grams (6 ounces) per 3.785 liters (1 U.S. gallon) of water. Warm this solution and circu-

late through the tubes until all slime and mud has been removed.

3. After cleaning, flush tubes thoroughly with fresh clean water.
4. Prepare a 15% by volume solution for de-scaling, by diluting Oakite Compound No. 32 with water. This is accomplished by slowly adding 0.47 liter (1 U.S. pint) of the acid (Oakite No. 32) to 2.8 liters (3 U.S. quarts) of water.

WARNING

Oakite No. 32 is an acid. Be sure that the acid is slowly added to the water. DO NOT PUT WATER INTO THE ACID - this will cause spattering and excessive heat.

WARNING

Wear rubber gloves and wash the solution from the skin immediately if accidental contact occurs. Do not allow the solution to splash onto concrete.

5. Fill the tubes with this solution by filling from the bottom. See Figure 6-7.

NOTE

It is important to provide a vent at the top for escaping gas.

6. Allow the Oakite No. 32 solution to soak in the tube coils for several hours, periodically pump-circulating it with an acid-proof pump.

An alternate method may be used whereby a pail (see Figure 6-8) filled with the solution and attached to the coils by a hose can serve the same purpose by filling and draining. The solution must contact the scale at every point for thorough de-scaling. Air pockets in the solution should be avoided by regularly opening the vent to release gas. *Keep flames away from the vent gases.*

7. The time required for de-scaling will vary, depending upon the extent of the deposits. One way to determine when de-scaling has been completed is to titrate the solution periodically, using titrating equipment provided free by the Oakite Technical Service representative. As scale is being dissolved, titrate readings will indicate that the Oakite No. 32 solution is losing strength. When the reading remains

constant for a reasonable time, this is an indication that scale has been dissolved.

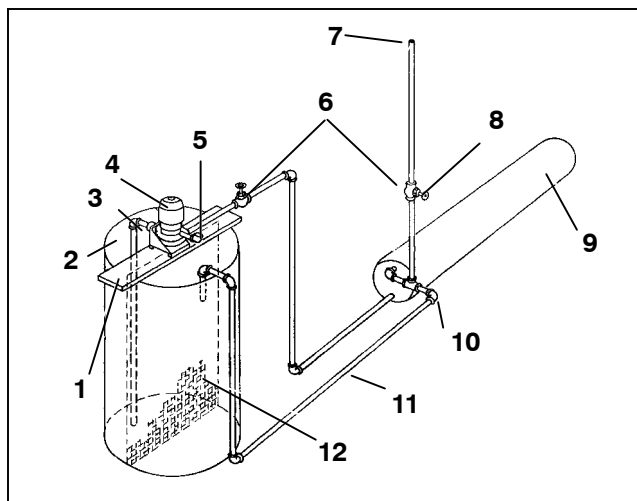

- | | |
|---|---|
| 1. Pump support | 7. Vent |
| 2. Tank | 8. Close vent pipe valve when pump is running |
| 3. Suction | 9. Condenser |
| 4. Pump | 10. Remove water regulating valve |
| 5. Priming Connection (Centrifugal pump 50 gpm at 35' head) | 11. Return |
| 6. Globe valves | 12. Fine mesh screen |

Figure 6-7 Water-Cooled Condenser Cleaning - Forced Circulation

8. When de-scaling is complete, drain the solution and flush thoroughly with water.
9. Following the water flush, circulate a 56.7 gram (2 ounce) per 3.785 liter (1 U.S. gallon) solution of Oakite No. 22 thru the tubes to neutralize. Drain this solution.
10. Flush the tubes thoroughly with fresh water.

NOTE

If the condenser cooling water is not being used as drinking water or is not re-circulated in a closed or tower system, neutralizing is not necessary.

11. Put the unit back in service and operate under normal load. Check the head pressure. If normal, a thorough de-scaling has been achieved.

What You Can Do For Further Help:

Contact the Engineering and Service Department of the OAKITE PRODUCTS CO., 675 Central Avenue, New Providence, NJ 07974 U.S.A. (or visit www.oakite.com) for the name and address of the service representative in your area.

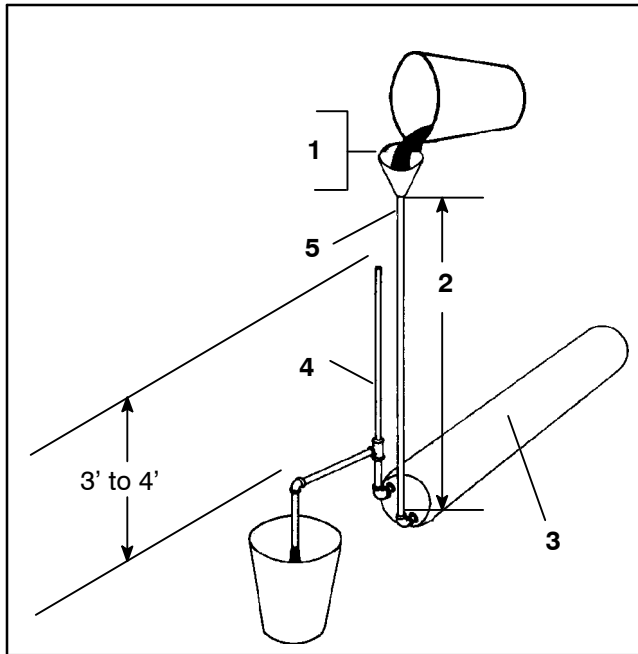

1. Fill condenser with cleaning solution. Do not add solution more rapidly than vent can exhaust gases caused by chemical action.
2. Approximately 5'
3. Condenser
4. Vent pipe
5. 1" pipe

Figure 6-8 Water-Cooled Condenser Cleaning - Gravity Circulation

6.9 FILTER DRIER

On units equipped with a water-cooled condenser, if the sight glass appears to be flashing or bubbles are constantly moving through the sight glass, the unit may have a low refrigerant charge or the filter drier could be partially plugged.

a. To Check Filter Drier

1. Test for a restricted or plugged filter drier by feeling the liquid line inlet and outlet connections of the drier cartridge. If the outlet side feels cooler than the inlet side, then the filter drier should be changed.
2. Check the moisture-liquid indicator if the indicator shows a high level of moisture, the filter drier should be replaced.

b. To Replace Filter Drier

1. Pump down the unit (refer to paragraph 6.3.2). Evacuate if unit is not equipped with service valves. Then replace filter drier.
2. Evacuate the low side in accordance with paragraph 6.3.4.
3. After unit is in operation, inspect for moisture in system and check charge.

6.10 EVAPORATOR COIL AND HEATER ASSEMBLY

The evaporator section, including the coil, should be cleaned regularly. The preferred cleaning fluid is fresh

water or steam. Another recommended cleaner is Oakite 202 or similar, following *manufacturer's instructions*.

The two drain pan hoses are routed behind the condenser fan motor and compressor. The drain pan line(s) must be open to ensure adequate drainage.

6.10.1 Evaporator Coil Replacement

- a. Pump unit down. (Refer to paragraph 6.3.2.) Evacuate if unit is not equipped with service valves. Refer to paragraph 6.3.4.
- b. With power OFF and power plug removed, remove the screws securing the panel covering the evaporator section (upper panel).
- c. Disconnect the defrost heater wiring.
- d. Remove the mounting hardware from the coil.
- e. Unsolder the two coil connections, one at the distributor and the other at the coil header.
- f. Disconnect the defrost temperature sensor (see Figure 2-2) from the coil.
- g. Remove middle coil support.
- h. After defective coil is removed from unit, remove defrost heaters and install on replacement coil.
- i. Install coil assembly by reversing above steps.
- j. Leak check connections. Evacuate and add refrigerant charge.

6.10.2 Evaporator Heater Replacement

The heaters are wired directly back to the contactor and if a heater failure occurs during a trip, the heater set containing that heater may be disconnected at the contactor.

The next pre-trip will detect that a heater set has been disconnected and indicate that the failed heater should be replaced. To replace a heater, do the following:

- a. Before servicing unit, make sure the unit circuit breakers (CB-1 and CB-2) and the start-stop switch (ST) are in the OFF position, and that the power plug is disconnected.
- b. Remove the upper back panel.
- c. Determine which heater(s) need replacing by checking resistance of each heater set. Refer to paragraph 2.3 for heater resistance values. Once the set containing the failed heater is determined, cut the splice connection and retest to determine the actual failed heater(s).
- d. Remove hold-down clamp securing heater(s) to coil.
- e. Lift the bent end of the heater (with the opposite end down and away from coil). Move heater to the side enough to clear the heater end support and remove.

6.11 EVAPORATOR FAN AND MOTOR ASSEMBLY

The evaporator fans circulate air throughout the container by pulling air in the top of the unit. The air is forced through the evaporator coil where it is either heated or cooled and then discharged out the bottom of the refrigeration unit into the container. The fan motor bearings are factory lubricated and do not require additional grease.

6.11.1 Replacing The Evaporator Fan Assembly



Always turn OFF the unit circuit breakers (CB-1 and CB-2) and disconnect main power supply before working on moving parts.

- a. Remove upper access panel (see Figure 2-2) by removing mounting bolts and TIR locking device. Reach inside of unit and remove the Ty-Rap securing the wire harness loop. Disconnect the connector by twisting to unlock and pulling to separate.
- b. Loosen four 1/4-20 clamp bolts that are located on the underside of the fan deck at the sides of the of the fan assembly. Slide the loosened clamps back from the fan assembly.
- c. Slide the fan assembly out from the unit and place on a sturdy work surface.

6.11.2 Disassemble The Evaporator Fan Assembly

- a. Attach a spanner wrench to the two 1/4-20 holes located in the fan hub. Loosen the 5/8-18 shaft nut by holding the spanner wrench stationary and turning the 5/8-18 nut counter-clockwise (see Figure 6-9).
- b. Remove the spanner wrench. Use a universal wheel puller and remove the fan from the shaft. Remove the washers and key.
- c. Remove the four 1/4-20 x 3/4 long bolts that are located under the fan that support the motor and stator housing. Remove the motor and plastic spacer.

6.11.3 Assemble The Evaporator Fan Assembly

- a. Assemble the motor and plastic spacer onto the stator.

NOTE

When removing the black nylon evaporator fan blade, care must be taken to assure that the blade is not damaged. In the past, it was a common practice to insert a screwdriver between the fan blades to keep it from turning. This practice can no longer be used, as the blade is made up of a material that will be damaged. It is recommended that an impact wrench be used when removing the blade. Do not use the impact wrench when reinstalling, as galling of the stainless steel shaft can occur.

- b. Apply Loctite to the 1/4-20 x 3/4 long bolts and torque to 0.81 mkg (70 inch-pounds).
- c. Place one 5/8 flat washer on the shoulder of the fan motor shaft. Insert the key in the keyway and lubricate

the fan motor shaft and threads with a graphite-oil solution (such as Never-seez).

- d. Install the fan onto the motor shaft. Place one 5/8 flat washer with a 5/8-18 locknut onto the motor shaft and torque to 40 foot-pounds.

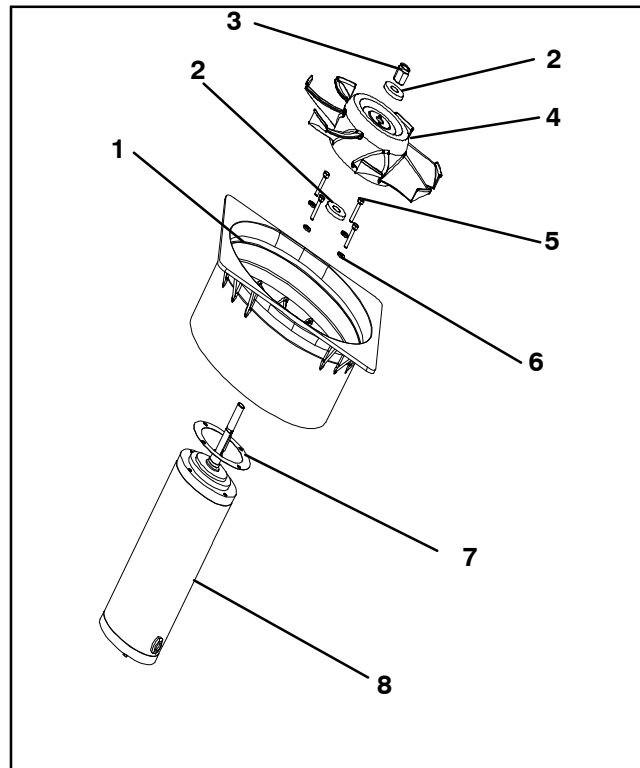

- | | |
|---------------------|---------------------|
| 1. Stator | 5. Screw, 1/4 |
| 2. Flat washer, 5/8 | 6. Flat washer, 1/4 |
| 3. Locknut, 5/8-18 | 7. Mylar Protector |
| 4. Impeller Fan | 8. Evaporator Motor |

Figure 6-9 Evaporator Fan Assembly

- e. Install the evaporator fan assembly in reverse order of removal. Torque the four 1/4-20 clamp bolts to 0.81 mkg (70 inch-pounds). Connect the wiring connector.
- f. Replace access panel making sure that panel does not leak. Make sure that the TIR locking device is lockwired.

6.12 ELECTRONIC EXPANSION VALVE

The electronic expansion valve (EEV) is an automatic device which maintains required superheat of the refrigerant gas leaving the evaporator. The valve functions are: (a) automatic response of refrigerant flow to match the evaporator load and (b) prevention of liquid refrigerant entering the compressor. Unless the valve is defective, it seldom requires any maintenance. See Figure 6-10.

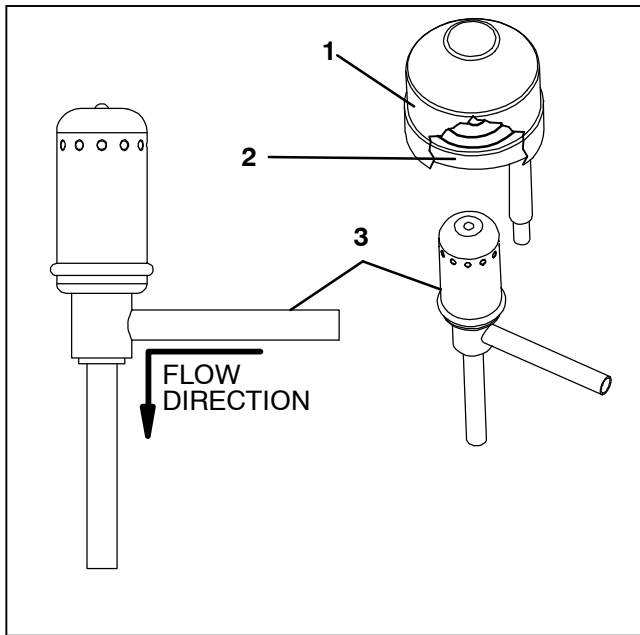

1. Coil Boot
2. Coil
3. Electronic Expansion Valve

Figure 6-10 Electronic Expansion Valve

6.12.1 Replacing Expansion Valve and Screen

- a. Pump down the unit. (Refer to Section 6.3.2.)
- b. Remove coil.
- c. Use a wet rag to keep valve cool whenever brazing. Heat inlet and outlet connections to valve body and remove valve. Clean all tube stubs so new valve fits on easily.
- d. Install new valve and screen, with cone of screen pointing into liquid line at inlet to the valve by reversing steps a. through c.
- e. During reinstallation, make sure the EEV coil is snapped down fully, and the coil retention tab is properly seated in one of the valve body dimples. Also, ensure that coil boot is properly fitted over valve body. See Figure 6-10.
- f. Evacuate by placing vacuum pump on liquid line and suction service valve.
- g. Open liquid line service valve and check refrigerant level.
- h. Check superheat. (Refer to Section 2.2)
- i. Check unit operation by running Pre-trip (Refer to Section 3.7).

6.13 ECONOMIZER EXPANSION VALVE

The economizer expansion valve can be found in Figure 2-4 (Item 15). The economizer expansion valve is an automatic device that maintains constant superheat of the refrigerant gas leaving at the point of bulb attachment, regardless of suction pressure.

Unless the valve is defective, it seldom requires maintenance other than periodic inspection to ensure that the thermal bulb is tightly secured to the suction line and wrapped with insulating compound.

6.13.1 Valve Replacement

- a. Removing an Expansion Valve

NOTES

1. The economizer expansion valve is a hermetic valve and does not have adjustable superheat (See Figure 6-11).

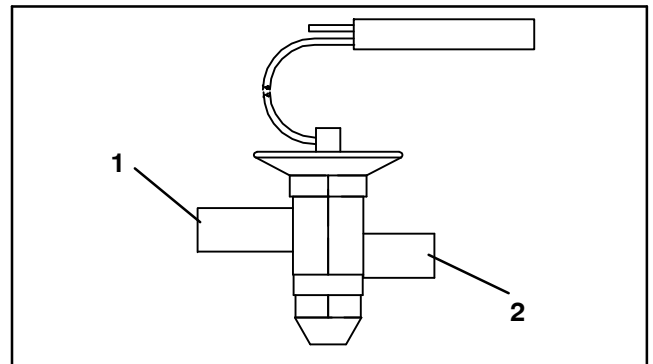

1. Inlet
2. Outlet

Figure 6-11 Economizer Expansion Valve

1. Pump down the unit per paragraph 6.3.2. Evacuate if unit is not equipped with service valves. Refer to paragraph 6.4.4.
2. Remove cushion clamps located on the inlet and outlet lines.
3. Remove insulation (Presstite) from expansion valve bulb.
4. Unstrap the bulb, located on the economizer line and remove the valve.
- b. Installing an Expansion Valve
 1. Braze inlet connection to inlet line, see Figure 6-12.
 2. Braze outlet connection to outlet line.
 3. The economizer valve should be wrapped in a soaked cloth for brazing. (See Figure 6-12). Braze inlet connection to inlet line.
 4. Braze outlet connection to outlet line.
 5. Reinstall the cushion clamps on inlet and outlet lines.
 6. Check superheat (see Section 2.2).

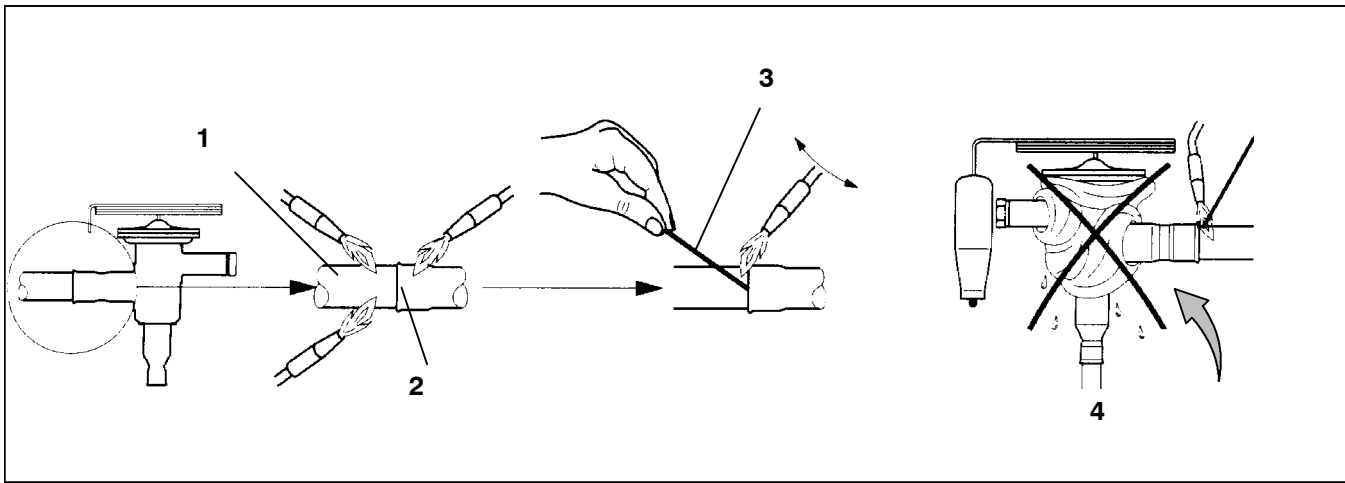

1. Copper Tube
(Apply heat for 10-15 seconds)

2. Bi-metallic Tube Connection
(Apply heat for 2-5 seconds)

3. Braze Rod
(“Sil-Phos” = 5.5% Silver, 6% Phosphorus)

4. Use of a wet cloth is not necessary due to rapid heat dissipation of the bi-metallic connections

Figure 6-12 Hermetic Thermostatic Expansion Valve Brazing Procedure

6.14 ECONOMIZER AND LIQUID INJECTION SOLENOID VALVES

a. Replacing the Coil

NOTE

The coil may be replaced without removing the refrigerant.

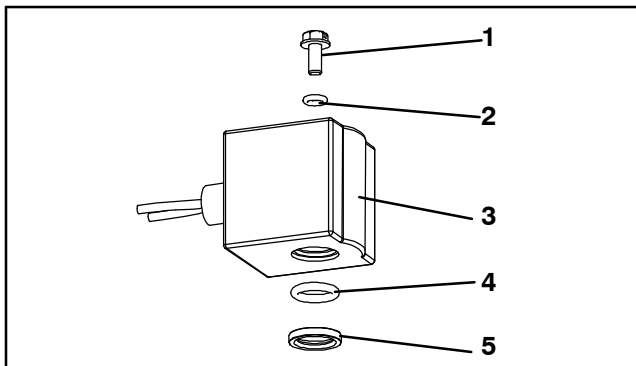

1. Slotted Screw
2. Top Coil (small) O-ring
3. Solenoid Coil, Enclosing Tube and Body
4. Bottom Coil (large) O-ring
5. Brass Spacer (**ESV ONLY**)

Figure 6-13 Coil View of Economizer Solenoid Valve (ESV) and Liquid Injection Valve (LIV)

1. Be sure electrical power is removed from the unit. Disconnect leads. Remove top screw and o-ring. Lift off coil. (See Figure 6-13).

2. Verify coil type, voltage and frequency of old and new coil. This information appears on the coil housing.

b. Replacing Valve

1. To replace the economizer or liquid injection valves, pump down the unit. Refer to paragraph 6.3.2. Evacuate if unit is not equipped with service valves. Refer to paragraph 6.4.4. To replace the oil return valve, remove the refrigerant charge.
2. Be sure electrical power is removed from the unit. Disconnect leads. Remove and discard the old coil and mounting hardware (See Figure 6-13).
3. Clean the valve stem with mild cleaner, if necessary.
4. Install the brass spacer on the valve stem if replacing the ESV **ONLY**. If replacing the LIV, discard brass spacer.
5. Lubricate both o-rings with silicone provided in the kit.
6. Install bottom coil o-ring on the valve stem.
7. Install the solenoid coil on the valve stem.
8. Place the top coil o-ring on the coil mounting screw and secure the coil to the valve using a torque-wrench. Torque the screw to 25 lb-in.
9. Connect coil wires using butt-splices and heat-shrink tubing.

6.15 DIGITAL UNLOADER VALVE

a. Removing the Coil

1. Pump down the compressor (refer to paragraph 6.3.2) and frontseat both suction and discharge valves. In the event the DUV is stuck open and compressor cannot pump down, remove charge.
2. Loosen bolt on top of the DUV and remove coil assembly.

NOTES

There is a loose steel spacer tube between the top of the valve and the 12 VDC coil that needs to be reinstalled into the solenoid valve coil. When removing the coil, it may fall out when lifted from the valve body. Take care that the spacer is not lost; the valve will not function correctly without it.

3. Remove clamps holding the DUV to the discharge line.
 4. Loosen the nuts attaching the DUV to the top of the compressor and the service valve.
 5. Remove the valve assembly.
 6. Examine compressor and service valves. Ensure that the o-rings are not stuck in the glands of the valves.
 7. Discard the o-rings on the o-ring face seal connections.
- b. Replacing the Coil
1. Install new DUV and tubing assembly; lubricate the gland shoulder area and o-rings with refrigerant oil.
 2. Hand-tighten the o-ring nuts.
 3. Re-install and tighten the brackets that secure the valve body to the discharge line.
 4. Torque o-ring face seal connections to 18 to 20 ft-lbs.
 5. Install the coil onto the valve body and tighten the attachment bolt.

NOTES

Confirm that the small spacer tube is inserted into the coil prior to attaching it to the valve body. The valve will not function correctly without it.

6. Leak check and evacuate low side or unit as applicable. Refer to paragraph 6.3.4.
7. Open service valves.

6.16 VALVE OVERRIDE CONTROLS

Controller function code Cd41 is a configurable code that allows timed operation of the automatic valves for troubleshooting. Test sequences are provided in Table 6-1. Capacity mode (CAP) allows alignment of the economizer solenoid valve in the standard and economized operating configurations. DUV Capacity Modulation, % Setting (PCnt) and Electronic Expansion Valve (EEV) allows opening of the digital unloader valve and electronic expansion valve, respectively, to various percentages. The Liquid Valve Setting (LIV) allows the LIV to be automatically controlled, or manually opened and closed.

The Override Timer (tIM) selection is also provided to enter a time period of up to five minutes, during which the override(s) are active. If the timer is active, valve override selections will take place immediately. If the timer is not active, changes will not take place for a few seconds after the timer is started. When the timer times out, override function is automatically terminated and the valves return to normal machinery control. To operate the override, do the following:

- a. Press the CODE SELECT key then press an ARROW key until Cd41 is displayed in the left window. The right window will display a controller communications code.
- b. Press the ENTER key. The left display will show a test name alternating with the test setting or time remaining. Use an ARROW key to scroll to the desired test. Press the ENTER key and SELCt will appear in the left display.
- c. Use an ARROW key to scroll to the desired setting, and then press the ENTER key. Selections available for each of the tests are provided in the following table.
- d. If the timer is not operating, follow the above procedure to display the timer. Use an ARROW key to scroll to the desired time interval and press ENTER to start the timer.
- e. The above described sequence may be repeated during the timer cycle to change to another override.

Table 6-1 Valve Override Control Displays

Left Display	Controller Communications Codes (Right Display)	Setting Codes (Right Display)
Cd 41/SELct	CAP (Capacity Mode)	AUto (Normal Control)
		Std UnLd (Economizer = Closed)
		ECON (Economizer = Open)
	PCnt (% Setting - DUV Capacity Modulation)	AUto (Normal Machinery Control) 0 3 6 10 25 50 100
	EEV (% Setting - Electronic Expansion Valve)	AUto (Normal Machinery Control) CLOSE (Closed) 0 3 6 10 25 50 100
	LIV (Liquid Valve Setting)	AUto (Normal Control)
		CLOSE (Closed)
		OPEn (Open)
	tIM (Override Timer)	0 00 (0 minutes/0 Seconds) In 30 second increments to 5 00 (5 minutes/ 0 seconds)

6.17 AUTOTRANSFORMER

If the unit does not start, check the following:

- Make sure the 460 VAC (yellow) power cable is plugged into the receptacle (item 3, Figure 4-1) and locked in place.
- Make sure that circuit breakers CB-1 and CB-2 are in the "ON" position. If the circuit breakers do not hold in, check voltage supply.
- There is no internal protector for this transformer design, therefore, no checking of the internal protector is required.
- Using a voltmeter, and with the primary supply circuit ON, check the primary (input) voltage (460 VAC). Next, check the secondary (output) voltage (230 VAC). The transformer is defective if output voltage is not available.

6.18 CONTROLLER

6.18.1 Handling Modules



CAUTION

Do not remove wire harnesses from module unless you are grounded to the unit frame with a static safe wrist strap.



CAUTION

Unplug all module connectors before performing arc welding on any part of the container.

The guidelines and cautions provided herein should be followed when handling the modules. These precautions and procedures should be implemented when replacing a module, when doing any arc welding on the unit, or when service to the refrigeration unit requires handling and removal of a module.

- Obtain a grounding wrist strap (Carrier Transicold part number 07-00304-00) and a static dissipation mat (Carrier Transicold part number 07-00277-00). The wrist strap, when properly grounded, will dissipate any potential buildup on the body. The dissipation mat will provide a static-free work surface on which to place and/or service the modules.
- Disconnect and secure power to the unit.
- Place strap on wrist and attach the ground end to any exposed unpainted metal area on the refrigeration unit frame (bolts, screws, etc.).

d. Carefully remove the module. Do not touch any of the electrical connections if possible. Place the module on the static mat.

e. The strap should be worn during any service work on a module, even when it is placed on the mat.

6.18.2 Controller Troubleshooting

A group of test points (TP, see Figure 6-14) are provided on the controller for troubleshooting electrical circuits (see schematic diagram, section 7). A description of the test points follows:

NOTE

Use a digital voltmeter to measure AC voltage between TP's and ground (TP9), except for TP8.

TP1

This test point is not used in this application.

TP2

This test point enables the user to check if the high pressure switch (HPS) is open or closed.

TP3

This test point enables the user to check if the water pressure switch (WP) contact is open or closed.

TP 4

This test point enables the user to check if the internal protector for the condenser fan motor (IP-CM) is open or closed.

TP 5

This test point enables the user to check if the internal protectors for the evaporator fan motors (IP-EM1 or IP-EM2) are open or closed.

TP 6

This test point enables the user to check if the controller liquid injection valve relay (TQ) is open or closed.

TP 7

This test point enables the user to check if the controller economizer solenoid valve relay (TS) is open or closed.

TP 8

This test point is not used in this application.

TP 9

This test point is the chassis (unit frame) ground connection.

TP 10

This test point enables the user to check if the heat termination thermostat (HTT) contact is open or closed.

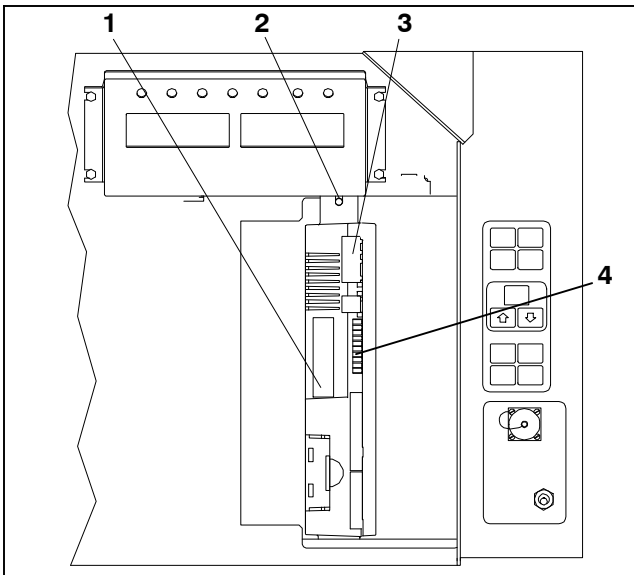

1. Controller Software Programming Port
2. Mounting Screw
3. Controller
4. Test Points

Figure 6-14 Controller Section of the Control Box

6.18.3 Controller Programming Procedure

To load new software into the module, the programming card is inserted into the programming/software port.



The unit must be OFF whenever a programming card is inserted or removed from the controller programming port.

1. Turn unit OFF, via start-stop switch (ST).
2. Insert software/programming PCMCIA card containing the following (example) files into the programming/software port. (See Figure 6-14):

menuDDMM.ml3, this file allows the user to select a file/program to upload into the controller.

cfYYMMDD.ml3, multi-configuration file.

3. Turn unit ON, via start-stop switch (ST).

If ruN COnFG is displayed, follow procedure 6.18.3.1 If Set UP is displayed, follow procedure 6.18.3.2.

6.18.3.1 Programming Procedure for Software Versions Prior to 5328 and/or Cards Without Updated Menu Option (menu0111.ml)

- a. Procedure for loading operational software:

1. The display module will display the message ruN COnFG. (If a defective card is being used the display will blink the message "bAd CArd." Turn start-stop switch OFF and remove the card.)
2. Press the UP or DOWN arrow key until display reads, LOAd 53XX for Scroll (odd numbers)
3. Press the ENTER key on the keypad.

4. The display will alternate to between PrESS Entr and rEV XXXX.
5. Press the ENTER key on the keypad.
6. The display will show the message "Pro SoFt". This message will last for up to one minute.
7. The display module will go blank briefly, then read "Pro donE" when the software loading has loaded. (If a problem occurs while loading the software: the display will blink the message "Pro FAIL" or "bad 12V." Turn start-stop switch OFF and remove the card.)
8. Turn unit OFF, via start-stop switch (ST).
9. Remove the PCMCIA card from the programming/software port and return the unit to normal operation by placing the start-stop switch in the ON position.
10. Turn power on, and wait 15 seconds. The status LED will flash quickly, and there will be no display. The controller is loading the new software into memory. This takes about 15 seconds.

When complete, the controller will reset and power up normally.

11. Wait for default display, setpoint on the left, and control temperature on the right.
12. Confirm software is correct using keypad code select 18 to view Cd18 XXXX.
13. Turn power off. Operational software is loaded.

- b. Procedure for loading configuration software:

1. Turn unit OFF using start-stop switch (ST).
2. Insert software/programming PCMCIA card containing the following (example) files into the programming/software port. (See Figure 6-14):

menuDDMM.ml3, this file allows the user to select the file/program to upload into the controller.

cfYYMMDD.ml3, multi-configuration file

3. Turn unit ON using start-stop switch (ST).
4. The display module will display the message ruN COnFG. (If a defective card is being used the display will blink the message "bAd CArd." Turn start-stop switch OFF and remove the card.)
5. Press the ENTER key on the keypad.
6. The display module will go blank briefly and then display "551 00", based on the operational software installed.
7. Press the UP or DOWN ARROW key to scroll through the list to obtain the proper model dash number. (If a defective card is being used, the display will blink the message "bAd CArd." Turn start-stop switch OFF and remove the card.)
8. Press the ENTER key on the keypad.
9. When the software loading has successfully completed, the display will show the message "EEPrM donE." (If a problem occurs while loading the software, the display will blink the message "Pro FAIL" or "bad 12V." Turn start-stop switch OFF and remove the card.)
10. Turn unit OFF using start-stop switch (ST).
11. Remove the PCMCIA card from the programming/software port and return the unit to normal operation by placing the start-stop switch in the ON position.

12. Confirm correct model configuration using the keypad to choose code 20 (CD20). The model displayed should match the unit serial number plate.

6.18.3.2 Programming Procedure for Software Versions 5328 and Later AND With Updated Menu Option (menu0111.ml)

The updated menu option allows the operational software to be loaded, and time and container identification to be set.

a. Procedure for loading operational software:

1. The display module will display the message Set UP.
2. Press the UP or DOWN arrow key until display reads, LOAd 53XX for Scroll (odd numbers)
3. Press the ENTER key on the keypad.
4. The display will alternate to between PrESS EntR and rEV XXXX.
5. Press the ENTER key on the keypad.
6. The display will show the message "Pro SoFt". This message will last for up to one minute.
7. The display module will go blank briefly, then read "Pro donE" when the software loading has loaded. (If a problem occurs while loading the software: the display will blink the message "Pro FAIL" or "bad 12V." Turn start-stop switch OFF and remove the card.)
8. Turn unit OFF, via start-stop switch (ST).
9. Remove the PCMCIA card from the programming/software port and return the unit to normal operation by placing the start-stop switch in the ON position.
10. Turn power on, and wait 15 seconds. The status LED will flash quickly, and there will be no display. The controller is loading the new software into memory. This takes about 15 seconds.

When complete, the controller will reset and power up normally.

11. Wait for default display, setpoint on the left, and control temperature on the right.
12. Confirm software is correct using keypad code select 18 to view Cd18 XXXX.
13. Turn power off. Operational software is loaded.

b. Procedure for loading configuration software:

1. Turn unit OFF using start-stop switch (ST).
2. Insert software/programming PCMCIA card containing the following (example) files into the programming/software port. (See Figure 6-14):
menuDDMM.ml3, this file allows the user to select the file/program to upload into the controller.
cfYYMMDD.ml3, multi-configuration file
3. Turn unit ON using start-stop switch (ST).
4. Press the UP or DOWN arrow key until display reads Set UP.
5. Press the ENTER key on the keypad.
6. Press the UP or DOWN arrow key until display reads XXXX the message ruN COOnFG. (If a defective card is being used the display will blink the message "bAd CArd." Turn start-stop switch OFF and remove the card.)

7. Press the ENTER key on the keypad.
8. The display module will go blank briefly and then display "551 00", based on the operational software installed.
9. Press the UP or DOWN ARROW key to scroll through the list to obtain the proper model dash number. (If a defective card is being used, the display will blink the message "bAd CArd." Turn start-stop switch OFF and remove the card.)
10. Press the ENTER key on the keypad.
11. When the software loading has successfully completed, the display will show the message "EEPrM donE." (If a problem occurs while loading the software, the display will blink the message "Pro FAIL" or "bad 12V." Turn start-stop switch OFF and remove the card.)
12. Turn unit OFF using start-stop switch (ST).
13. Remove the PCMCIA card from the programming/software port and return the unit to normal operation by placing the start-stop switch in the ON position.
14. Confirm correct model configuration using the keypad to choose code 20 (CD20). The model displayed should match the unit serial number plate.

c. Procedure for setting the date and time:

1. Press the UP or DOWN arrow key until display reads Set TIM.
2. Press the ENTER key on the keypad.
3. The first value to be modified is the date in YYYY MM-DD format. The values will be entered from right to left. Press the UP or DOWN ARROW key to increase or decrease the values. The ENTER key will enter the information for the current field and move to the next value; the CODE SELECT key will allow modification of the previous value.
4. Press the ENTER key on the keypad.
5. The next value to be modified is the time in HH MM format. The values will be entered from right to left. Press the UP or DOWN ARROW key to increase or decrease the values. The ENTER key will enter the information for the current field and move to the next value; the CODE SELECT key will allow modification of the previous value.
6. Press the ENTER key on the keypad. The date and time will not be committed until start up procedures are completed on the next power up.

d. Procedure for setting the container ID:

NOTE

The characters will be preset to the container ID already on the controller. If none exist, the default will be AAAA0000000.

1. Press the UP or DOWN arrow key until display reads Set ID.
2. Press the ENTER key on the keypad.
3. The values will be entered from right to left. Press the UP or DOWN ARROW key to increase or decrease the values. The ENTER key will enter the information for the current field and move to the next value; the CODE SELECT key will allow modification of the previous value.

4. When the last value is entered, press the ENTER key to enter the information to the controller; the CODE SELECT key will allow modification of the previous value.

6.18.4 Removing and Installing a Module

a. Removal:

1. Disconnect all front wire harness connectors and move wiring out of way.
2. The lower controller mounting is slotted, loosen the top mounting screw (see Figure 6-14) and lift up and out.
3. Disconnect the back connectors and remove module.
4. When removing the replacement module from its packaging, note how it is packaged. When returning the old module for service, place it in the packaging in the same manner as the replacement. The packaging has been designed to protect the module from both physical and electrostatic discharge damage during storage and transit.

b. Installation:

Install the module by reversing the removal steps.

Torque values for mounting screws (item 2, see Figure 6-14) are 0.23 mkg (20 inch-pounds). Torque value for the connectors is 0.12 mkg (10 inch-pounds).

6.18.5 Battery Replacement

Standard Battery Location (Standard Cells):

- a. Turn unit power OFF and disconnect power supply.
- b. Slide bracket out and remove old batteries. (See Figure 3-4, Item 8.)
- c. Install new batteries and slide bracket into control box slot.



CAUTION

Use care when cutting wire ties to avoid nicking or cutting wires.

Standard Battery Location (Rechargeable Cells):

- a. Turn unit power OFF and disconnect power supply.
- b. Disconnect battery wire connector from control box.
- c. Slide out and remove old battery and bracket. (See Figure 3-4, Item 8.)
- d. Slide new battery pack and bracket into the control box slot.
- e. Reconnect battery wire connector to control box and replace wire ties that were removed.

Secure Battery Option (Rechargeable Cells Only):

- a. Turn unit power OFF and disconnect power supply.
- b. Open control box door and remove both the high voltage shield and clear plastic rain shield (if installed).
- c. Disconnect the battery wires from the "KA" plug positions 14, 13, 11.
- d. Using Driver Bit, Carrier Transicold part number 07-00418-00, remove the 4 screws securing the dis-

play module to the control box. Disconnect the ribbon cable and set the display module aside.

NOTE

The battery wires must face toward the right.

- e. Remove the old battery from the bracket and clean bracket surface. Remove the protective backing from the new battery and assemble to the bracket. Secure battery by inserting the wire tie from the back of the bracket around the battery, and back through the bracket.
- f. Reconnect the ribbon cable to display and re-install the display.
- g. Route the battery wires from the battery along the display harness and connect the red battery wire and one end of the red jumper to "KA14," the other end of the red jumper wire to "KA11," and the black wire to "KA13."
- h. Replace wire ties that were removed.

6.19 VENT POSITION SENSOR SERVICE

The fresh air vent position sensor alarm (AL50) will occur if the sensor reading is not stable for four minutes or if the sensor is outside of its valid range (shorted or open). This can occur if the vent is loose or the panel is defective. To confirm a defective panel, assure that the wing nut is secure and then power cycle the unit. If the alarm immediately reappears as active, the panel should be replaced.

The alarm should immediately go inactive, check the 4-minute stability requirement. If the alarm reoccurs after the four minutes and the panel was known to have been stable, then the sensor should be replaced.

In order to replace the VPS, the panel must be removed and replaced with another upper fresh air panel equipped with VPS.

Upon installation, a new vent position sensor assembly requires calibration as follows:

1. Rotate the vent to the 0 CMH/ CFM position.
2. Code select 45 will automatically display. Press the Enter key and hold for five seconds.
3. After the enter key has been pressed the display will read CAL (for calibration).
4. Press the ALT MODE key and hold for five seconds.
5. After the calibration has been completed, Code 45 will display 0 CMH / CFM.

a. Lower Vent Position Sensor Calibration

Calibration of the Lower VPS is only required when the air makeup slide, motor or sensor has been repaired or serviced.

The VPS is calibrated using the keypad:

1. Remove the two nuts that secure the air makeup panel slide to the unit.
2. Rotate the gear clockwise until it stops.
3. Rotate the gear 1/4 turn counterclockwise.
4. Carefully reposition the slide onto the air makeup panel, given that the gear is engaged with the rail and has not moved.
5. Position slide panel to the fully closed position.

6. Code select Cd45 will automatically be shown on the left display.
7. Depress the ENTER key and hold for five seconds. CAL for calibration is displayed.
8. Depress the ALT MODE key on the keypad and hold for five seconds.
9. When calibration has been completed, Cd45 causes 0 CMH/CFM to be shown on the right display.
10. Secure the air makeup panel slide to the unit with the two nuts; stake threads.

6.20 TEMPERATURE SENSOR SERVICE

Procedures for service of the return recorder, return temperature, supply recorder, supply temperature, ambient, defrost temperature, evaporator temperature, and compressor discharge temperature sensors are provided in the following sub paragraphs.

6.20.1 Sensor Checkout Procedure

To check a sensor reading, do the following:

- a. Remove the sensor and place in a 0C (32F) ice-water bath. The ice-water bath is prepared by filling an insulated container (of sufficient size to completely immerse bulb) with ice cubes or chipped ice, then filling voids between ice with water and agitating until mixture reaches 0C (32F) measured on a laboratory thermometer.
- b. Start unit and check sensor reading on the control panel. The reading should be 0C (32F). If the reading is correct, reinstall sensor; if it is not, continue with the following.
- c. Turn unit OFF and disconnect power supply.
- d. Refer to paragraph 6.18 and remove controller to gain access to the sensor plugs.
- e. Using the plug connector marked "EC" that is connected to the back of the controller, locate the sensor wires (RRS, RTS, SRS, STS, AMBS, DTS, or CPDS as required). Follow those wires to the connector and using the pins of the plug, measure the resistance. Values are provided in Table 6-2.

Due to the variations and inaccuracies in ohmmeters, thermometers or other test equipment, a reading within 2% of the chart value would indicate a good sensor. If a sensor is defective, the resistance reading will usually be much higher or lower than the resistance values given.

Table 6-2 Sensor Temperature/Resistance Chart (+/- .002%)

Temperature		Resistance	
C	F	(Ohms)	
		AMBS, DTS, RTS, RRS, STS, SRS	CPDS
-30	-22	177,000	1,770,000
-25	-13	130,400	1,340,000
-20	-4	97,070	970,700
-15	5	72,900	729,000
-10	14	55,330	553,000
-5	23	43,200	423,300
0	32	32,650	326,500
5	41	25,390	253,900
10	50	19,900	199,000
15	59	15,700	157,100
20	68	12,490	124,900
25	77	10,000	100,000
30	86	8,060	80,600
35	95	6,530	65,300
40	104	5,330	53,300
45	113	4,370	43,700
50	122	3,600	36,000
55	131	2,900	29,000
60	140	2,490	24,900
65	149	2,080	20,800
65	158	1,750	17,500

6.20.2 Sensor Replacement

- a. Turn unit power OFF and disconnect power supply.
- b. Cut cable 5 cm (2 inches) from shoulder of defective sensor and discard the defective probe only. Slide the cap and grommet off a bulb type sensor and save for reuse. **Do not cut the grommet.**
- c. Cut one wire of existing cable 40 mm (1-1/2 inches) shorter than the other wire.
- d. Cut one replacement sensor wire (opposite color) back 40 mm (1-1/2 inches). (See Figure 6-15.)
- e. Strip back insulation on all wiring 6.3 mm (1/4 inch).

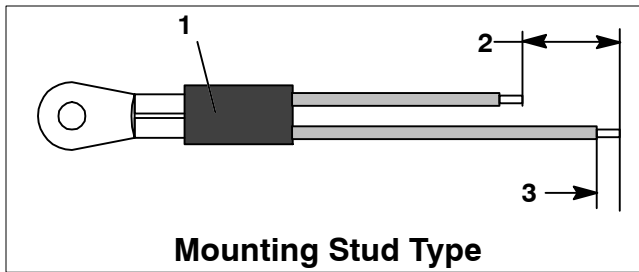

Mounting Stud Type

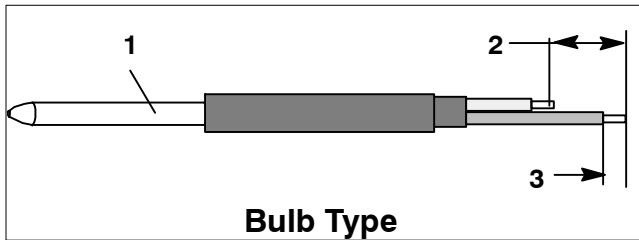

Bulb Type

1. Sensor
2. 40 mm (1 1/2 in.)
3. 6.3 mm (1/4 in.)

Figure 6-15 Sensor Types

- f. Slide a large piece of heat shrink tubing over the cable, and place the two small pieces of heat shrink tubing, one over each wire, before adding crimp fittings as shown in Figure 6-16.

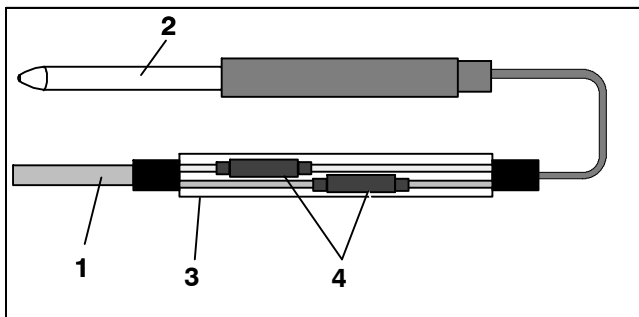

1. Cable
2. Sensor (Typical)
3. Large Heat Shrink Tubing (1)
4. Heat Shrink Tubing (2)

Figure 6-16 Sensor and Cable Splice

- g. Slide large heat shrink tubing over both splices and shrink.
h. If required, slide the cap and grommet assembly onto the replacement sensor.
i. Slip crimp fittings over dressed wires (keeping wire colors together). Make sure wires are pushed into crimp fittings as far as possible and crimp with crimping tool.

- j. Solder spliced wires with a 60% tin and 40% lead Rosincore solder.
k. Slide heat shrink tubing over splice so that ends of tubing cover both ends of crimp as shown in Figure 6-16.
l. Heat tubing to shrink over splice. Make sure all seams are sealed tightly against the wiring to prevent moisture seepage.



CAUTION

Do not allow moisture to enter wire splice area as this may affect the sensor resistance.

- m. Position sensor in unit as shown in Figure 6-16 and re-check sensor resistance.
n. Reinstall sensor, refer to paragraph 6.20.3.

NOTE

The P5 Pre-Trip test must be run to inactivate probe alarms (refer to paragraph 4.8).

6.20.3 Sensor Re-Installation

Sensors STS and SRS

To properly position a supply sensor, the sensor must be fully inserted into the probe holder. See Figure 6-17. Do not allow heat shrink covering to contact the probe holder. For proper placement of the sensor, be sure to position the enlarged positioning section of the sensor against the the side of the mounting clamp. This positioning will give the sensor the optimum amount of exposure to the supply air stream, and will allow the controller to operate correctly.

Sensors RRS and RTS

Reinstall the return sensor as shown in Figure 6-18. For proper placement of the return sensor, be sure to position the enlarged positioning section of the sensor against the the side of the mounting clamp. See Figure 6-18.

Sensor DTS

The DTS sensor must have insulating material placed completely over the sensor to ensure the coil metal temperature is sensed.

Sensors ETS1 and ETS2

The ETS1 and ETS2 sensors are located in tube holders under insulation, as illustrated in Figure 6-19. When sensors are removed and reinstalled, they must be placed in tube holders and insulating material must completely cover the sensor to ensure the correct temperature is sensed.

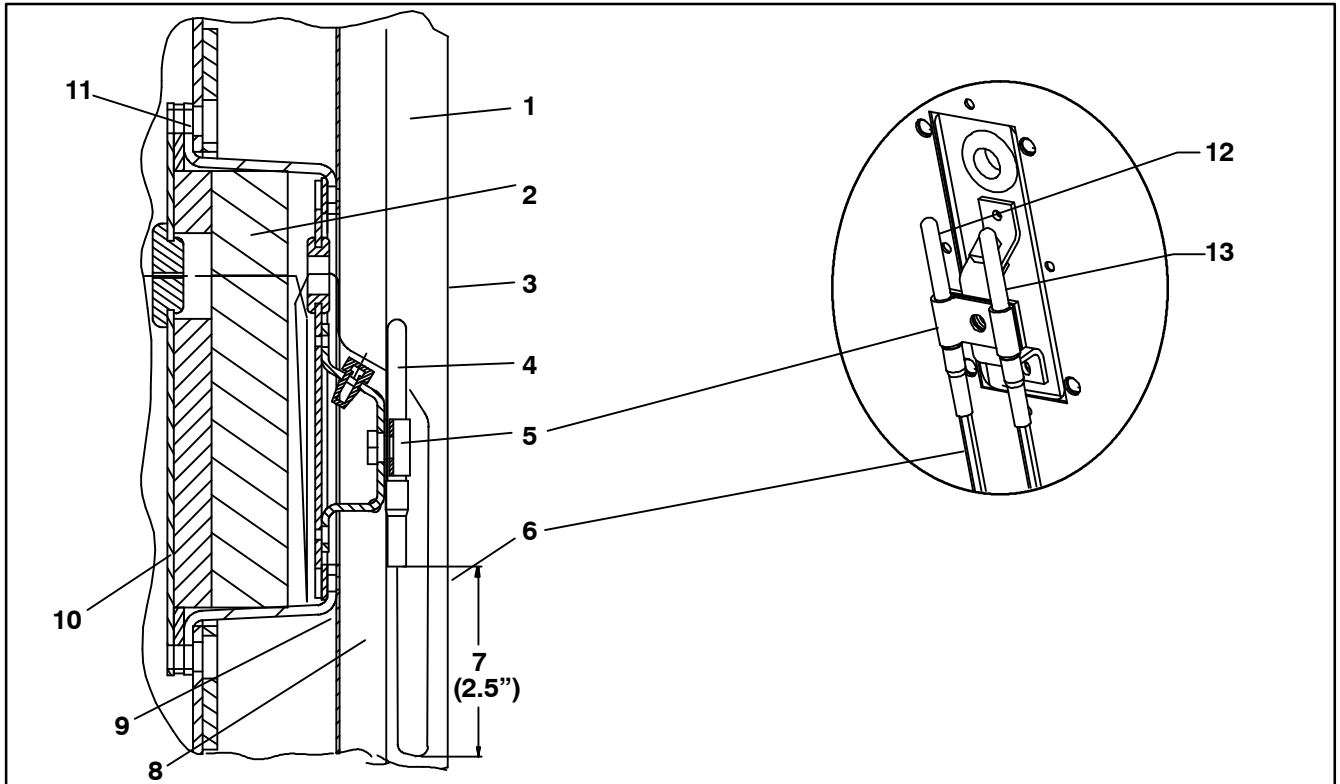

- | | |
|----------------------|---------------------------|
| 1. Supply Air Stream | 8. Gasket Mounting Plate |
| 2. Insulation | 9. Gasketed Support Plate |
| 3. Back Panel | 10. Gasketed Cover |
| 4. Supply Sensor | 11. TIR Bolts |
| 5. Mounting Clamp | 12. STS Probe |
| 6. Sensor Wires | 13. SRS Probe |
| 7. Drip Loop | |

Figure 6-17 Supply Sensor Positioning

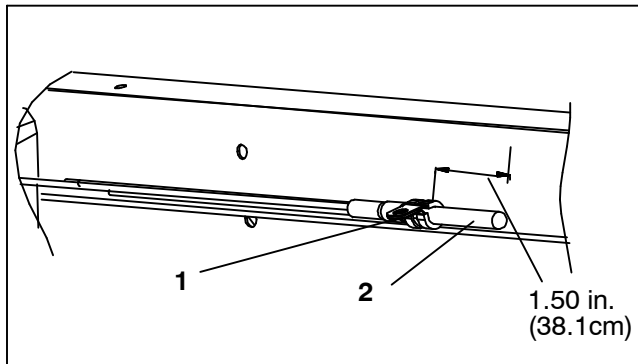

1. Mounting Clamp
2. Return Sensor

Figure 6-18 Return Sensor Positioning

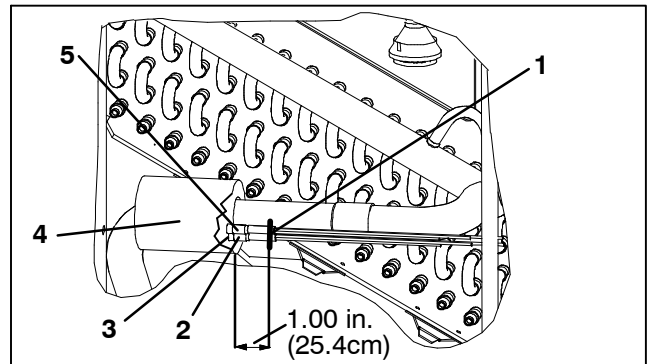

- | | |
|---------------------|---------------|
| 1. Wire Tie | 4. Insulation |
| 2. ETS1 | 5. ETS2 |
| 3. ETS Tube Holders | |

Figure 6-19 Evaporator Temperature Sensor Positioning

6.21 ELECTRONIC PARTLOW TEMPERATURE RECORDER

The microprocessor-based temperature recorder is designed to interface with the DataCORDER to log temperature with time. The electronic recorder will automatically record the return air, supply air, or both, based on the setting of temperature controller configuration code CnF37, refer to Table 3-4. The recorder reads and records data from the controller in present time, under normal operating conditions.

If the power has been OFF for more than thirty days, the recorder will NOT re-synchronize (the chart will not advance to present time), the pen tip will move to the currently recorded temperature, and the recorder will resume normal temperature recording.

If using the Electronic Partlow Recorder CTD part number 12-00464-xx

Where xx= an even number (example: 12-00464-08)

The recorder will STOP when the power is OFF, and the pen tip will remain at the last recorded temperature on the chart. When power is applied, and the power off period is less than thirty days, the recorder will retrieve the logged data from the DataCORDER for the power off period and record it onto the chart. Thereafter, the recorder will resume normal temperature recording.

If the optional DataCORDER battery pack is being used and the charge is too low to enable recording during the power off period of less than thirty days, the pen tip will move to below the inner chart ring for the period when NO data was recorded by the DataCORDER.

If the power has been OFF for more than thirty days, the recorder will NOT re-synchronize (the chart will not advance to present time), the pen tip will move to the currently recorded temperature, and the recorder will resume normal temperature recording.

6.21.1 Replacing the Recorder

- a. Turn power to the unit OFF.
- b. Open the recorder door (item 1, see Figure 6-20).

- c. Locate the connector below the recorder, and squeeze the ears together to disconnect the plug (item 10).
- d. Remove the four mounting screws (item 2), and remove the recorder.
- e. Install the new recorder by reversing the above steps.

6.21.2 Changing the Chart

NOTE

To prevent recorder corrosion, it is important to assure the door is securely closed at all times after completing the chart change.

- a. Lift the stylus (item 5, Figure 6-20) by grasping the arm near the base, and pull the arm away from the chart until it snaps into its retracted position.
- b. Remove the chart retaining nut (item 10), remove the used chart, and record current date on the old chart.
- c. Press the "Change Chart" button (item 2).

NOTE

Failure to press the change chart button, when changing a chart with the power OFF, may result in the chart advancing when power is applied.

- d. Install a new chart, make sure the chart center hole is placed over the center hub, and the chart edges are behind the four hold down tabs (item 9).
- e. Mark the current date, container number, and other required information on the new chart and install under hold down tabs.
- f. Replace the chart nut loosely, rotate the chart until the correct day is aligned with the "start arrow," and hand tighten the chart nut.
- g. Gently lower the stylus arm until the pen tip (item 4) comes in contact with the chart.

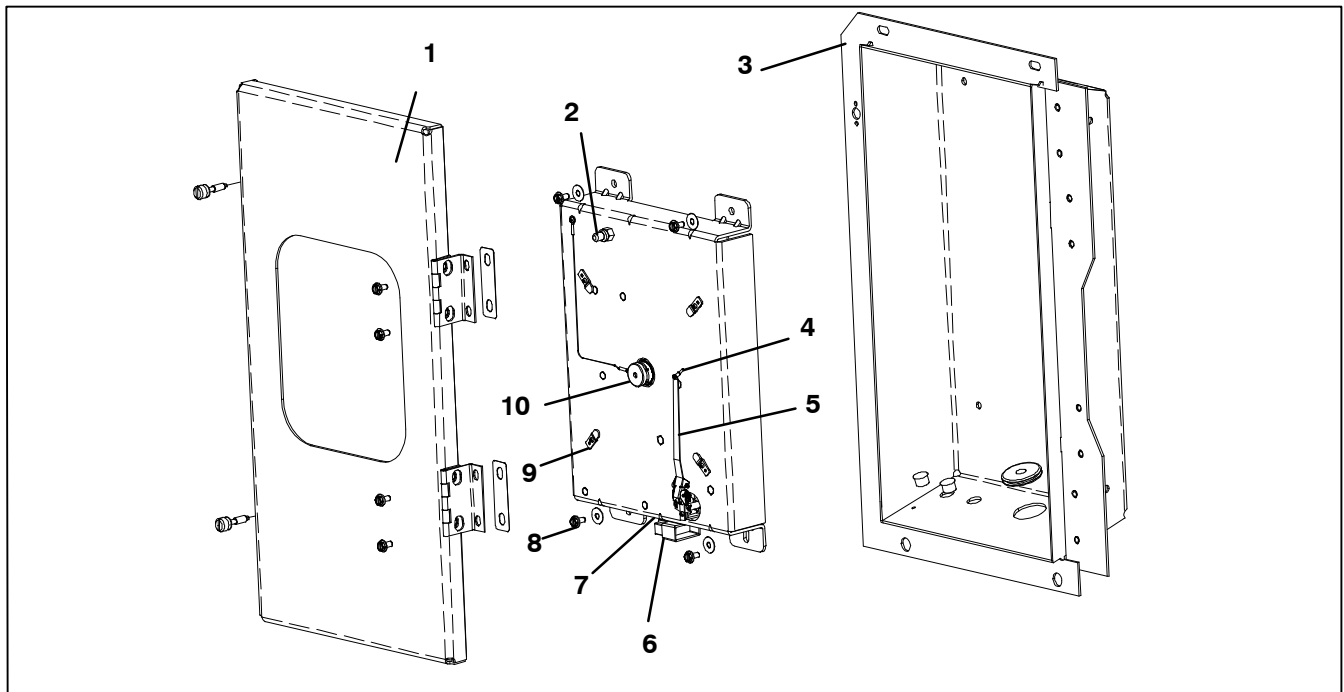

- | | |
|--|--|
| <ul style="list-style-type: none"> 1. Recorder Door 2. Change Chart Button 3. Recorder Box 4. Pen Tip 5. Stylus Arm | <ul style="list-style-type: none"> 6. Connector 7. Calibration Button
(Located underneath) 8. Mounting Screws,
#10-24 x 7/16 inches long 9. Hold Down Tab 10. Chart Retaining Nut |
|--|--|

Figure 6-20 Electronic Partlow Temperature Recorder

CAUTION

Do not allow the recorder stylus to snap back down. The stylus arm base is spring loaded, and damage may occur to the chart, or the stylus force may be altered.

DO NOT move the stylus arm up and down on the chart face. This will result in damage to the stylus motor gear.

6.21.3 Adjusting the Recorder Stylus

Proper stylus force upon the chart paper is important. Factory adjustment is 113 to 127 grams (4 to 4.5 oz). To measure the force, use a spring type gage and attach it under the stylus as close as possible to the pen tip (item 4). Exert pull on the gage perpendicular to the chart surface. The measured force should be noted just as the pen tip leaves the surface.

NOTE

The two coil springs near the base of the stylus are NOT involved in establishing chart contact force. They serve only to hold the stylus in its retracted position.

Correct adjustment is made by carefully bending the portion of the stylus arm between the bend near the pen tip, and the first bend towards the stylus arm base. If the force is too low, the stylus trace will be light and difficult to read. If the force is too great, wrinkling, or tearing of the paper chart may occur.

6.21.4 Rezeroing the Recording Thermometer

**For Electronic Partlow Recorder CTD part number 12-00464-xx
Where xx= an odd number (example: 12-00464-03)**

NOTE

Use chart CTD part number 09-00128-00 (F)
part number 09-00128-01 (C).

- a. Press the "Calibration" button (item 7, Figure 6-20) on the bottom of the recorder. The pen tip will drive fully down scale, then move upscale to the chart ring at -29C (-20F), and stop.
- b. If the tip of the pen (item 4) is on the -29C (-20F) chart ring, the recorder is in calibration, proceed to step c. If the tip of the pen is NOT on the -29C (-20F) chart ring, the operator must loosen the two screws on the bottom of the stylus arm to adjust the pen tip manually to the -29C (-20F) chart ring. Tighten the screws when adjustment is complete.
- c. Press the calibration button and the pen will position itself to the correct temperature reading.

For Electronic Partlow Recorder CTD part number 12-00464-xx
Where xx= an even number (example: 12-00464-08)

NOTE

Use chart CTD part number 09-00128-00 (F)
 part number 09-00128-01 (C).

- a. Press the "Calibration" button (item 7, Figure 6-20) on the bottom of the recorder. The pen tip will drive fully down scale, then move upscale to the chart ring at 0C (32F), and stop.
- b. If the tip of the pen (item 4) is on the 0C (32F) chart ring the recorder is in calibration, proceed to step c. If the tip of the pen is NOT on the 0C (32F) chart ring, the operator must loosen the two screws on the bottom of the stylus arm to adjust the pen tip manually to the 0C (32F) chart ring. Tighten the screws when adjustment is complete.
- c. Press the calibration button and the pen will position itself to the correct temperature reading.

6.22 MAINTENANCE OF PAINTED SURFACES

The refrigeration unit is protected by a special paint system against the corrosive atmosphere in which it normally operates. However, should the paint system be damaged, the base metal can corrode. In order to protect the refrigeration unit from the highly corrosive sea atmosphere, or if the protective paint system is scratched or damaged, clean area to bare metal using a wire brush, emery paper or equivalent cleaning method. Immediately following cleaning, apply two-part epoxy paint to the area. and allow to dry. After the first coat dries, apply a second coat.

6.23 COMMUNICATIONS INTERFACE MODULE INSTALLATION

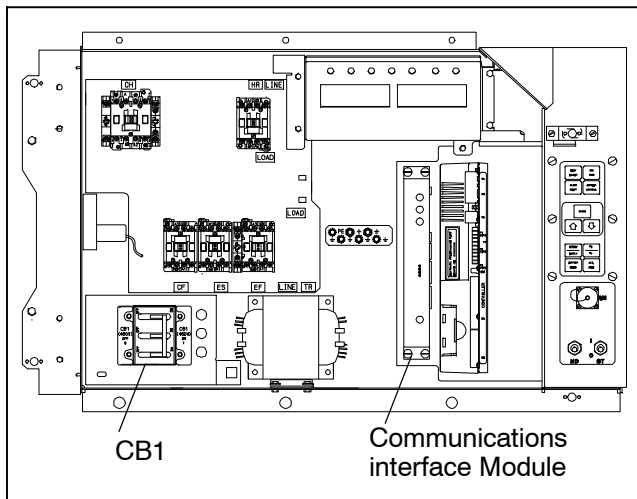

Figure 6-21 Communications Interface Installation

Units that have been factory provisioned for installation of a communication interface module (CIM) have the required wiring installed. If the unit is not factory provisioned, a provision wiring kit (Carrier Transicold part

number 76-00685-00) must be installed. Installation instructions are packaged with the kit. To install the module, do the following:

⚠ WARNING

Installation requires wiring to the main unit circuit breaker, CB1. Make sure the power to the unit is off and power plug disconnected before beginning installation.

- a. CB1 is connected to the power system, see wiring schematic. Ensure that the unit power is off AND that the unit power plug is disconnected.
- b. Open control box, see Figure 6-21 and remove low voltage shield. Open high voltage shield.
- c. If using factory provisioned wiring, remove the circuit breaker panel, with circuit breaker, from the control box. Locate, wires CB21/CIA3, CB22/CIA5 and CB23/CIA7 that have been tied back in the wire harness. Remove the protective heat shrink from the ends of the wires.
- d. Refit the circuit breaker panel.
- e. Fit the new CIM into the unit.
- f. Attach three wires CB21/CIA3, CB22/CIA5 and CB23/CIA7 to the CIM at connection CIA.
- g. Locate connectors CIA and CIB, remove plugs if required, and attach to the module.
- h. Replace the low voltage shield.

Table 6-3 Recommended Bolt Torque Values

BOLT DIA.	THREADS	TORQUE	Nm
FREE SPINNING			
#4	40	5.2 in-lbs	0.6
#6	32	9.6 in-lbs	1.1
#8	32	20 in-lbs	2.0
#10	24	23 in-lbs	2.5
1/4	20	75 in-lbs	8.4
5/16	18	11 ft-lbs	15
3/8	16	20 ft-lbs	28
7/16	14	31 ft-lbs	42
1/2	13	43 ft-lbs	59
9/16	12	57 ft-lbs	78
5/8	11	92 ft-lbs	127
3/4	10	124 ft-lbs	171
NONFREE SPINNING (LOCKNUTS ETC.)			
1/4	20	82.5 in-lbs	9.3
5/16	18	145.2 in-lbs	16.4
3/8	16	22.0 ft-lbs	23
7/16	14	34.1 ft-lbs	47
1/2	13	47.3 ft-lbs	65
9/16	12	62.7 ft-lbs	86
5/8	11	101.2 ft-lbs	139
3/4	10	136.4 ft-lbs	188

Table 6-4 R-134a Temperature - Pressure Chart

Temperature		Vacuum			
F	C	"/hg	cm/hg	kg/cm ²	bar
-40	-40	14.6	49.4	37.08	0.49
.35	.37	12.3	41.6	31.25	0.42
-30	-34	9.7	32.8	24.64	0.33
-25	-32	6.7	22.7	17.00	0.23
-20	-29	3.5	11.9	8.89	0.12
-18	-28	2.1	7.1	5.33	0.07
-16	-27	0.6	2.0	1.52	0.02
Temperature		Pressure			
F	C	psig	kPa	kg/cm ²	bar
-14	-26	0.4	1.1	0.03	0.03
-12	-24	1.2	8.3	0.08	0.08
-10	-23	2.0	13.8	0.14	0.14
-8	-22	2.9	20.0	0.20	0.20
-6	-21	3.7	25.5	0.26	0.26
-4	-20	4.6	31.7	0.32	0.32
-2	-19	5.6	36.6	0.39	0.39
0	-18	6.5	44.8	0.46	0.45
2	-17	7.6	52.4	0.53	0.52
4	-16	8.6	59.3	0.60	0.59
6	-14	9.7	66.9	0.68	0.67
8	-13	10.8	74.5	0.76	0.74
10	-12	12.0	82.7	0.84	0.83
12	-11	13.2	91.0	0.93	0.91
14	-10	14.5	100.0	1.02	1.00
16	-9	15.8	108.9	1.11	1.09
18	-8	17.1	117.9	1.20	1.18
20	-7	18.5	127.6	1.30	1.28
22	-6	19.9	137.2	1.40	1.37
24	-4	21.4	147.6	1.50	1.48
26	-3	22.9	157.9	1.61	1.58

Temperature		Pressure			
F	C	psig	kPa	kg/cm ²	bar
28	-2	24.5	168.9	1.72	1.69
30	-1	26.1	180.0	1.84	1.80
32	0	27.8	191.7	1.95	1.92
34	1	29.6	204.1	2.08	2.04
36	2	31.3	215.8	2.20	2.16
38	3	33.2	228.9	2.33	2.29
40	4	35.1	242.0	2.47	2.42
45	7	40.1	276.5	2.82	2.76
50	10	45.5	313.7	3.20	3.14
55	13	51.2	353.0	3.60	3.53
60	16	57.4	395.8	4.04	3.96
65	18	64.1	441.0	4.51	4.42
70	21	71.1	490.2	5.00	4.90
75	24	78.7	542.6	5.53	5.43
80	27	86.7	597.8	6.10	5.98
85	29	95.3	657.1	6.70	6.57
90	32	104.3	719.1	7.33	7.19
95	35	114.0	786.0	8.01	7.86
100	38	124.2	856.4	8.73	8.56
105	41	135.0	930.8	9.49	9.31
110	43	146.4	1009	10.29	10.09
115	46	158.4	1092	11.14	10.92
120	49	171.2	1180	12.04	11.80
125	52	184.6	1273	12.98	12.73
130	54	198.7	1370	13.97	13.70
135	57	213.6	1473	15.02	14.73
140	60	229.2	1580	16.11	15.80
145	63	245.6	1693	17.27	16.93
150	66	262.9	1813	18.48	18.13
155	68	281.1	1938	19.76	19.37

SECTION 7

ELECTRICAL WIRING SCHEMATICS

7.1 INTRODUCTION

This section contains the Electrical Schematics and Wiring Diagrams. The diagrams are presented as follows:

Figure 7-1 provides the legend for use with all figures.

Figure 7-2 provides the basic schematic diagram for units covered in this manual.

Figure 7-3 provides the schematic and wiring diagrams for Upper and Lower Vent Positioning Sensor (VPS).

Figure 7-4 basic wiring diagram for units covered in this manual.

Sequence of operation descriptions for the various modes of operation are provided in paragraph 3.3.

LEGEND			
<u>SYMBOL DESCRIPTION</u>	<u>SYMBOL DESCRIPTION</u>		
AMBS	AMBIENT SENSOR (C-21)	HR	HEATER CONTACTOR (P-4, M-13)
C	CONTROLLER (J-19)	HS	HUMIDITY SENSOR (OPTIONAL) (F-21)
CB1	CIRCUIT BREAKER - 460 VOLT (F-1)	HTT	HEAT TERMINATION THERMOSTAT (G-13)
CB2	OPTIONAL CIRCUIT BREAKER - DVM (OPTION) (C-1) TERMINAL BLOCK WHEN CB2 NOT PRESENT	ICF	INTERROGATOR CONNECTOR FRONT (T-21)
CF	CONDENSER FAN CONTACTOR (M-11, P-6)	ICR	INTERROGATOR CONNECTOR REAR (T-22)
CH	COMPRESSOR CONTACTOR (M-7, P-1)	IP	INTERNAL PROTECTOR (E-12, H-10, H-12)
CI	COMMUNICATIONS INTERFACE MODULE (OPTION) (A-3)	IRL	IN RANGE LIGHT (L-14)
CL	COOL LIGHT (OPTION) (M-11)	LIV	LIQUID INJECTION SOLENOID VALVE (K-10)
CM	CONDENSER FAN MOTOR (H-10, T-6)	PA	UNIT PHASE CONTACTOR (L-1, M-6)
CP	COMPRESSOR MOTOR (T-1)	PB	UNIT PHASE CONTACTOR (L-3, M-7)
CPDS	DISCHARGE TEMPERATURE SENSOR (B-21)	PR	USDA PROBE RECEPTACLE (E-21, L-22, M-22)
CR	CHART (TEMPERATURE) RECORDER (OPTIONAL) (A-15)	RM	REMOTE MONITORING RECEPTACLE (OPTION) (L-6, M-6, L-11, M-11, L-14, M-14)
CS	CURRENT SENSOR (J-2)	RRS	RETURN RECORDER SENSOR (C-21)
DHBL	DEFROST HEATER - BOTTOM LEFT (R-5)	RTS	RETURN TEMPERATURE SENSOR (B-21)
DHBR	DEFROST HEATER - BOTTOM RIGHT (T-4)	SPT	SUCTION PRESSURE TRANSDUCER (G-21)
DHML	DEFROST HEATER - MIDDLE LEFT (R-4)	SRS	SUPPLY RECORDER SENSOR (K-21)
DHMR	DEFROST HEATER - MIDDLE RIGHT (T-4)	ST	START - STOP SWITCH (G-4, G-5)
DHTL	DEFROST HEATER - TOP LEFT (R-4)	STS	SUPPLY TEMPERATURE SENSOR (A-21)
DHTR	DEFROST HEATER - TOP RIGHT (T-5)	TC	CONTROLLER RELAY-COOLING (H-7)
DL	DEFROST LIGHT (OPTION) (L-6)	TCC	TRANSFRESH COMMUNICATIONS CONNECTOR (OPTION) (D-5)
DPT	DISCHARGE PRESSURE TRANSDUCER (J-21)	TCP	CONTROLLER RELAY - COMPRESSOR PHASE SEQUENCING (K-6, K-7)
DTS	DEFROST TEMPERATURE SENSOR (C-21)	TE	CONTROLLER RELAY - HIGH SPEED EVAPORATOR FANS (K-12)
DUV	DIGITAL UNLOADER VALVE (E-22)	TH	CONTROLLER RELAY - HEATING (K-13)
DVM	DUAL VOLTAGE MODULE (OPTIONAL) (D-1)	TI	IN-RANGE RELAY (F-14)
DVR	DUAL VOLTAGE RECEPTACLE (OPTIONAL) (F-1)	TL	CONTROLLER RELAY - COOL LIGHT (K-11)
EEV	ELECTRONIC EXPANSION VALVE (N-15)	TN	CONTROLLER RELAY - CONDENSER FAN (K-10)
EF	EVAPORATOR FAN CONTACTOR-HIGH SPEED (M-12, N-8)	TP	TEST POINT (F-8, F-9, F-10, H-7, J-10, J-12, M-15)
EM	EVAPORATOR FAN MOTOR (D-12, F-12, T-7, T-10)	TQ	CONTROLLER RELAY-LIQUID INJECTION (E-9)
EPT	EVAPORATOR PRESSURE TRANSDUCER (R-14)	TR	TRANSFORMER (M-3)
ES	EVAPORATOR FAN CONTACTOR-LOW SPEED (M-11, P-7)	TRANS	AUTO TRANSFORMER 230/460 (OPTION) (D-2)
ETS	EVAPORATOR TEMPERATURE SENSOR (SUCTION) (D-16, D-21)	TRC	TRANSFRESH REAR CONNECTOR (OPTION) (E-5)
ESV	ECONOMIZER SOLENOID VALVE (K-9)	TS	CONTROLLER RELAY - ECONOMIZER SOLENOID VALVE (E-9)
F	FUSE (C-6, D-6, D-18, E-18)	TV	CONTROLLER RELAY - LOW SPEED EVAPORATOR FANS (J-11)
FLA	FULL LOAD AMPS	WCR	WETTING CURRENT RESISTOR (OPTION) (H-10)
HPS	HIGH PRESSURE SWITCH (G-7)	WP	WATER PRESSURE SWITCH (OPTION) (D-10)

Figure 7-1 LEGEND

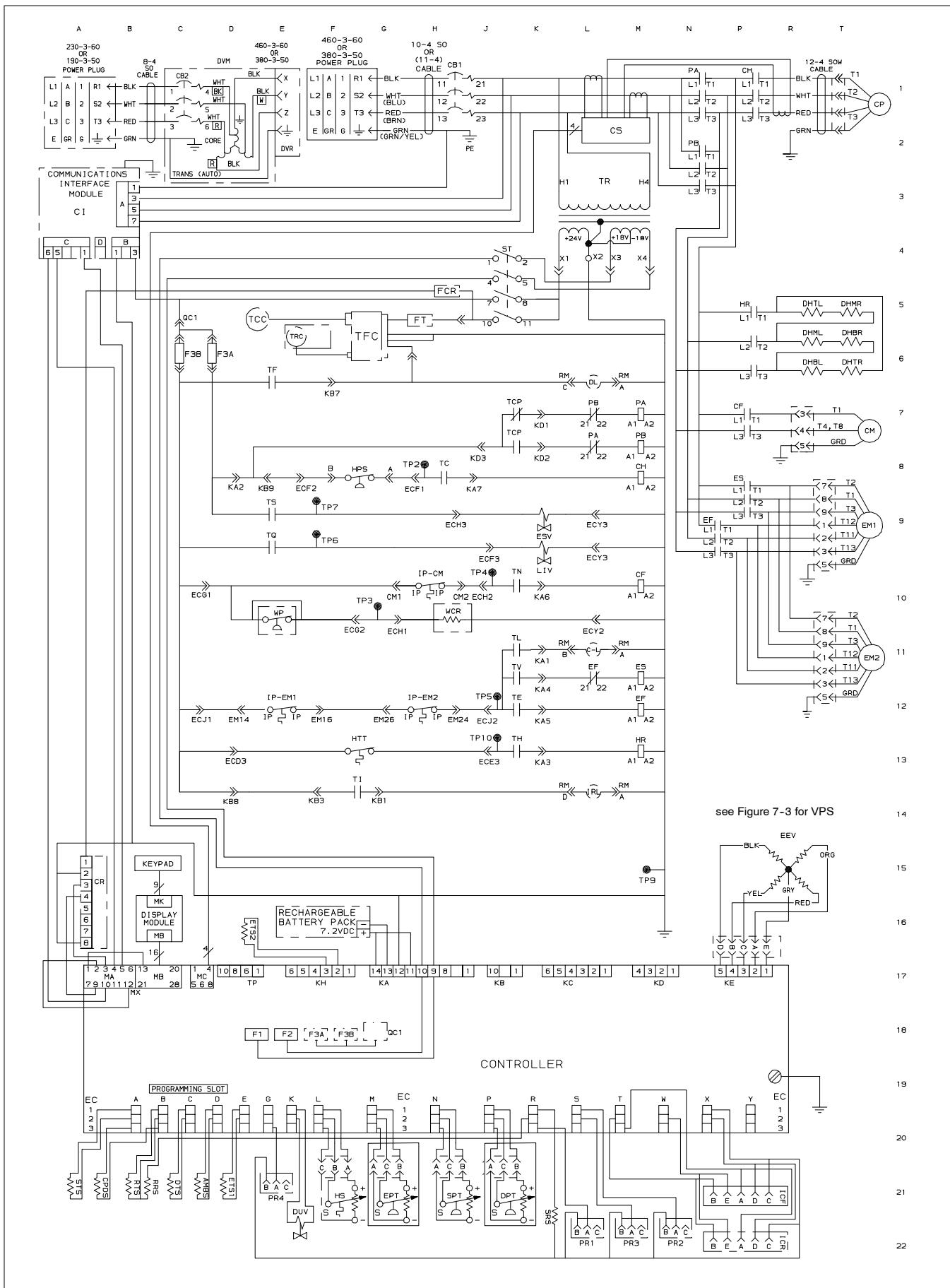
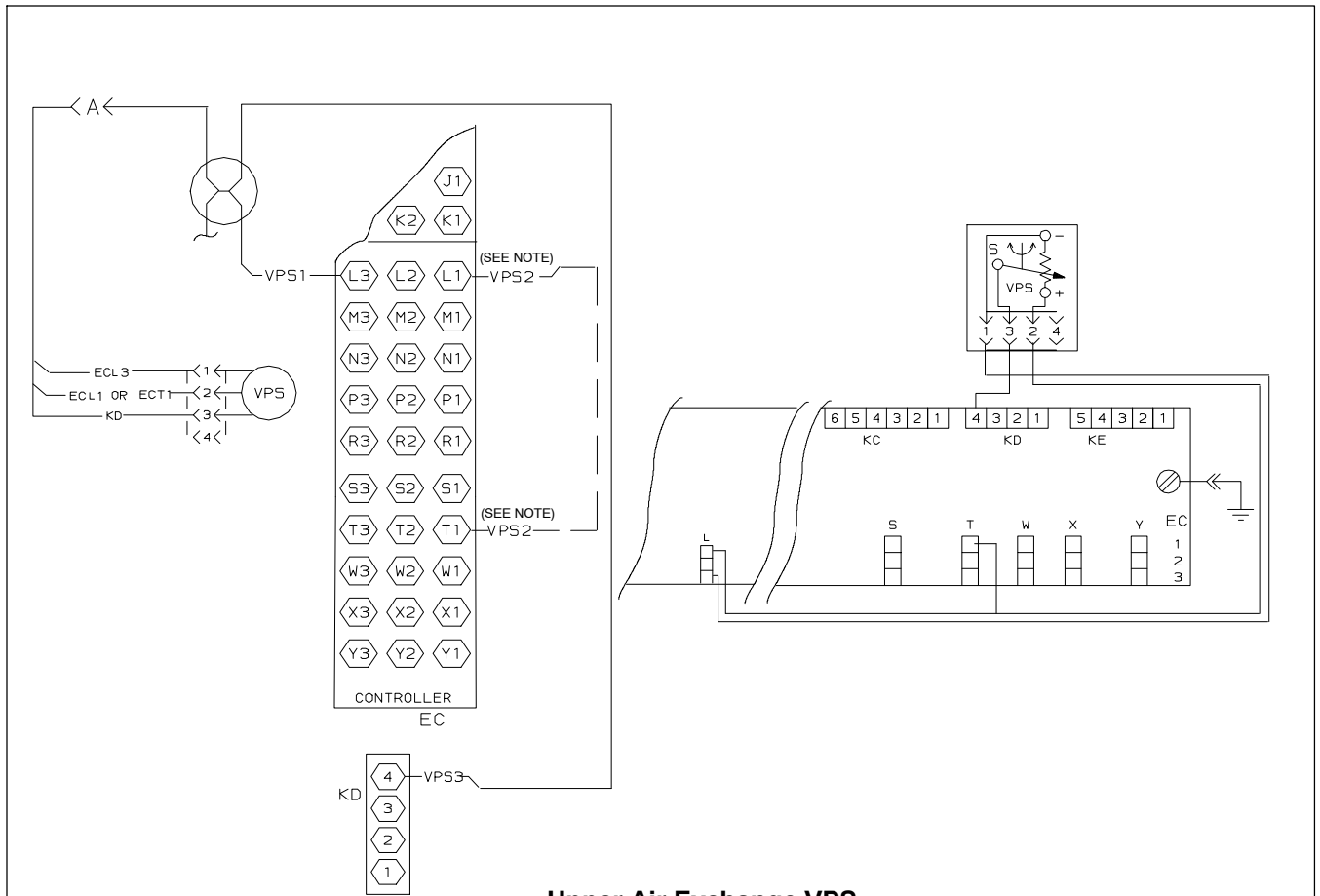
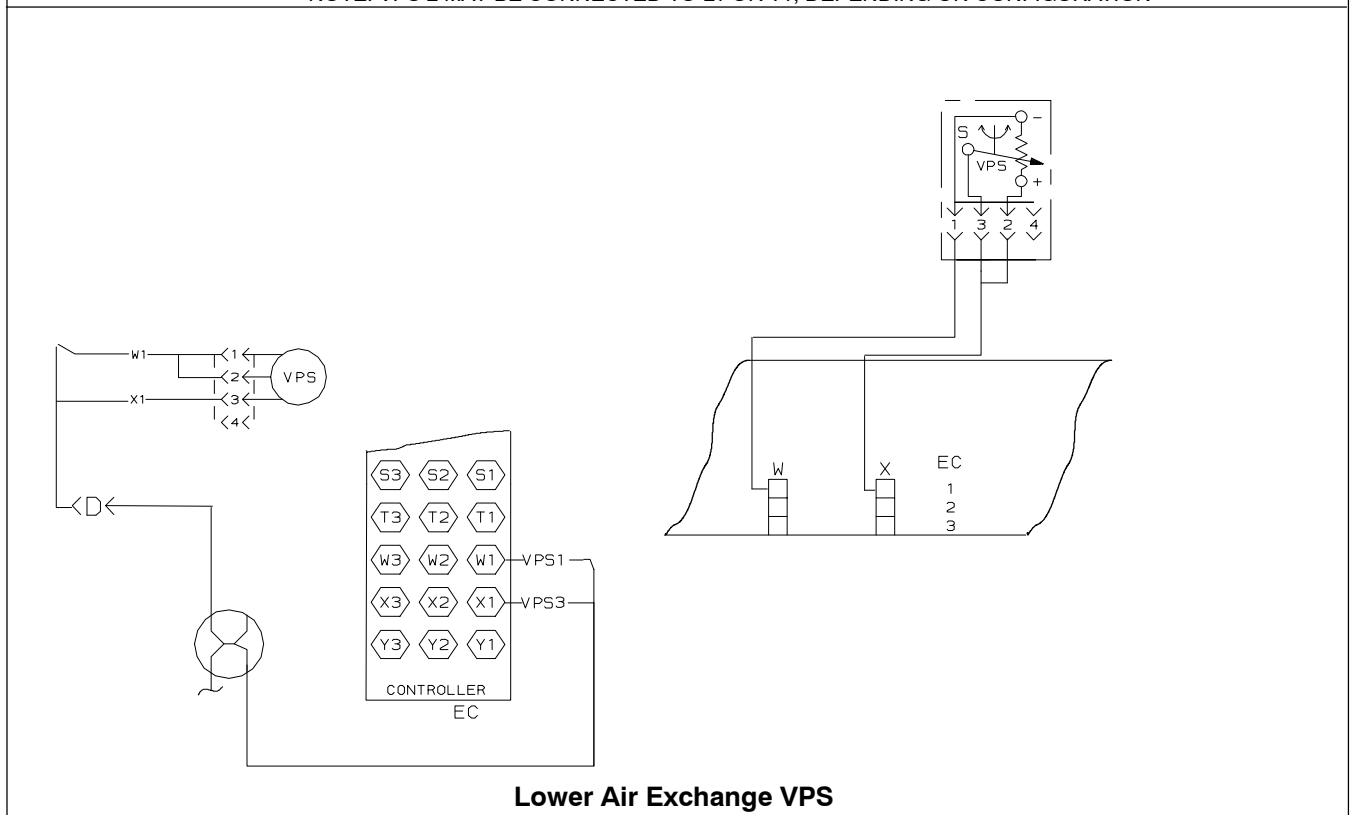

Figure 7-2 SCHEMATIC DIAGRAM



Upper Air Exchange VPS

NOTE: VPS 2 MAY BE CONNECTED TO L1 OR T1, DEPENDING ON CONFIGURATION



Lower Air Exchange VPS

Figure 7-3 SCHEMATIC AND WIRING DIAGRAM - Vent Position Sensors (VPS)

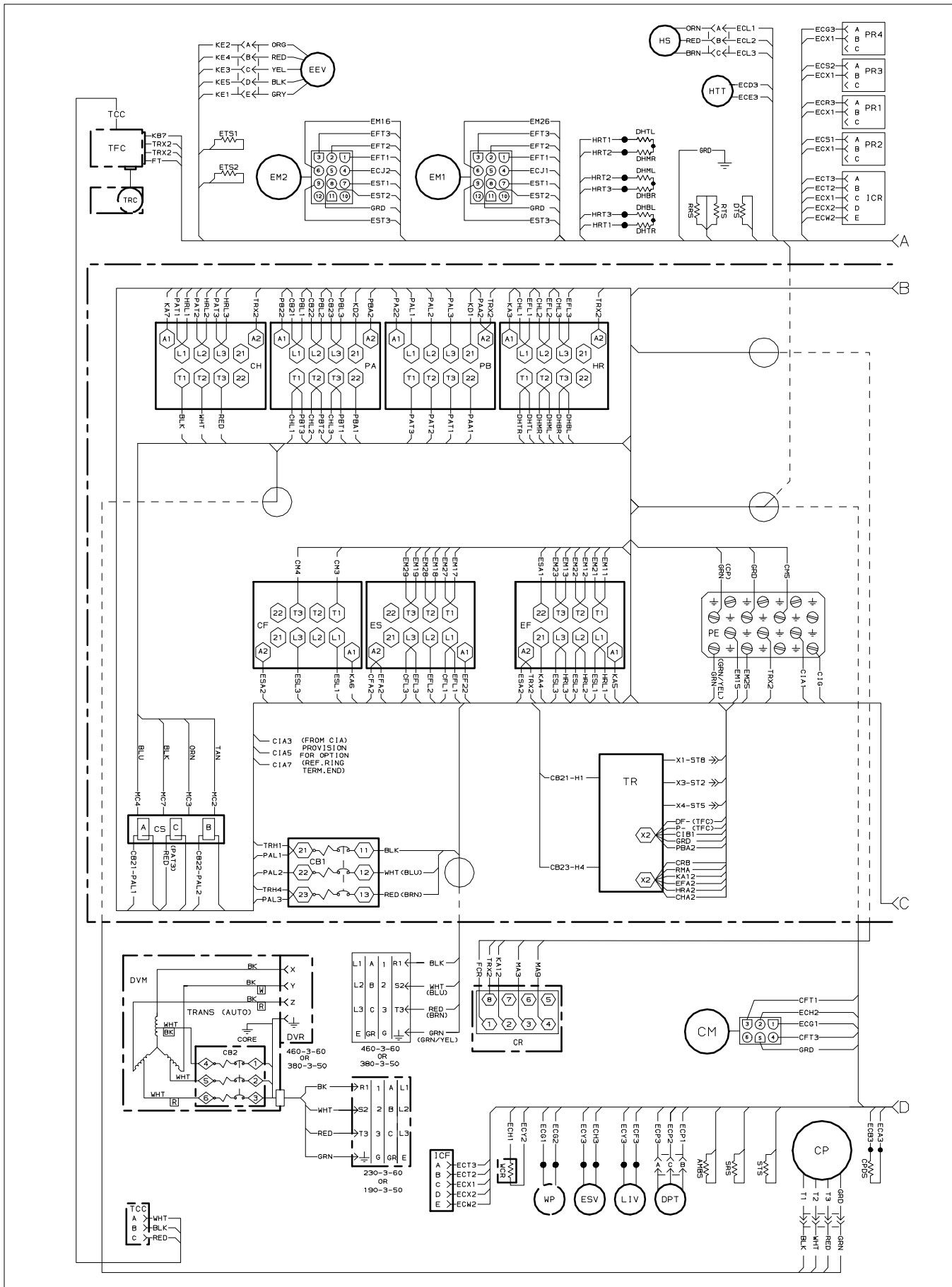

Figure 7-4 UNIT SCHEMATIC DIAGRAM (Sheet 1 of 2)

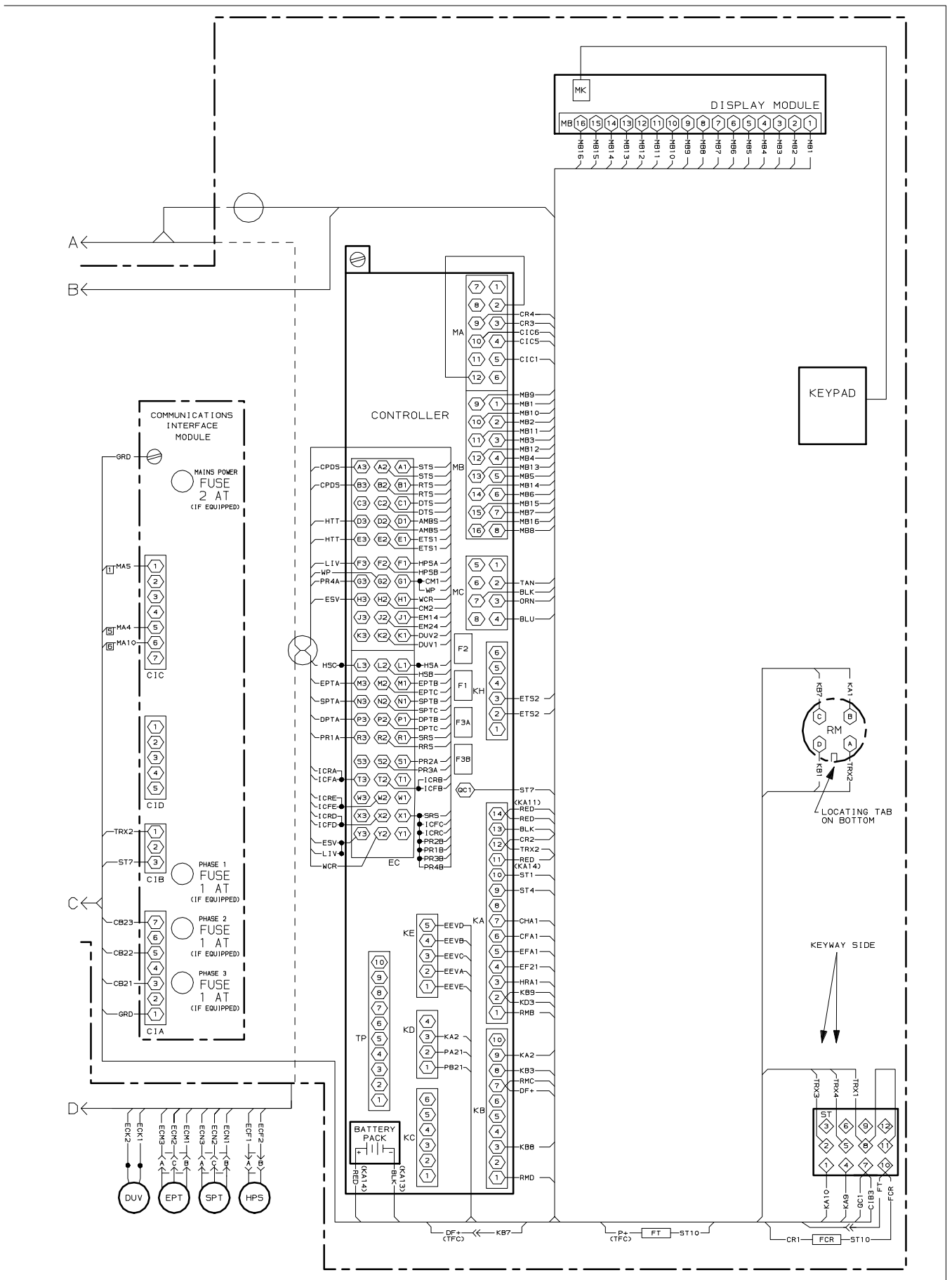

Figure 7-4 UNIT SCHEMATIC DIAGRAM (Sheet 2 of 2)

INDEX

A

Adjusting Fresh Air Makeup, 4-1
Air-Cooled Condenser Section, 2-4
Alarm Configuration, 3-14
Autotransformer, 6-15

B

Battery Replacement, 6-18

C

Capacity Trim Heat, 3-6
Communications Interface Module, 2-6, 3-15, 6-24
Compressor, 6-4
Compressor Section, 2-3
Condenser Coil, 6-6
Condenser Fan, 6-7
Condenser Pressure Control, 3-10
Configuration Identification, 1-1
Configuration Software, 3-3, 3-12
Connect Remote Monitoring Receptacle, 4-3
Connect Water-Cooled Condenser, 4-2
Connecting Power, 4-1
Control Box Section, 2-6
Controller, 3-3, 6-15
Controller Alarms, 3-10, 3-23
Controller Configuration Codes, 3-17
Controller Function Codes, 3-19
Controller Sequence and Modes of Operation, 3-4
Controller Software, 3-3

D

DataCORDER, 3-11, 3-14, 4-3
DataCORDER Alarms, 3-16, 3-33
DataCORDER Communications, 3-14
DataCORDER Function Codes, 3-31
DataCORDER Pre-Trip Codes, 3-32
DataCORDER Software, 3-11
DataReader, 3-14

DataView, 3-15
Defrost Interval, 3-9
Defrost Mode - Sequence of Operation, 3-9
Digital Unloader Valve, 6-12
Display Module, 3-2

E

Economized Operation, Refrigeration Circuit, 2-10
Economizer Expansion Valve, 6-11
Electrical Data, 2-8
Electronic Expansion Valve, 2-10, 6-10
Evacuation, 6-3
Evaporator, 2-2, 6-9
Evaporator Fan, 6-9
Evaporator Fan Operation, 3-10

F

Failure Action, 3-10
Filter Drier, 6-9
Fresh Air Makeup, 2-1
Frozen - Pulldown Mode, 3-7
Frozen Mode - Conventional, 3-7
Frozen Mode - Economy, 3-7
Frozen Mode Cooling - Sequence of Operation, 3-8
Frozen Mode Temperature Control, 3-7

G

Generator Protection, 3-10

H

Heat Lockout, 3-4, 3-7
Heater, 6-9
High Pressure Switch, 6-6
High Temperature, Low Pressure Protection, 3-10

I

Inspection, 4-1
ISO Trip Header, 3-16

INDEX (Continued)

K

Keypad, 3-2

L

Liquid Injection Valve Operation, 2-10

Logging Interval, 3-12

Lower Fresh Air Makeup Vent, 4-2

M

Manifold Gauge Set, 6-1

Microprocessor System, 3-1

Modes of Operation, 3-10

O

Operational Software, 3-3, 3-12

Option Description, 1-1

P

Painted Surfaces, 6-24

Perishable- System Pressure Regulation, 3-10

Perishable Mode - Bulb, 3-7

Perishable Mode - Dehumidification, 3-6

Perishable Mode Cooling - Sequence of Operation,
3-5

Perishable Mode Heating - Sequence of Operation,
3-6

Perishable Set Point Temperature - Conventional
Temperature Control Mode, 3-4

Perishable Set Point Temperature - Economy Mode,
3-4

Perishable Set Point Temperature - Perishable Pull-
down, 3-4

Perishable Set Point Temperature Control, 3-4

Pre-Trip Data Recording, 3-14

Pre-Trip Diagnosis, 3-11, 4-3

Pre-Trip Test Codes , 3-27

Probe Check, 4-4

Pumping Down, 6-2

R

Refrigerant Charge, 6-4

Refrigeration Circuit, 2-10

Refrigeration System Data, 2-7

Refrigeration System, Units with Service Valves, 6-2

Refrigeration Unit - Front Section, 2-1

S

Safety and Protective Devices, 2-9

Sampling Type, 3-14

Sensor Configuration, 3-12

Solenoid Valves, 6-12

Standard Operation, Refrigeration Circuit, 2-10

Start up - Compressor Bump Start, 3-4

Start up - Compressor Phase Sequence, 3-4

Start-Up Inspection, 4-3

Starting Instructions, 4-3

Stopping Instructions, 4-3

T

Temperature Recorder, 4-3, 6-22

Temperature Sensor, 6-18, 6-19

Thermistor Format, 3-12

Torque Values, 6-24

Troubleshooting, 5-1

U

Upper Fresh Air Makeup Vent, 4-2

USDA, 3-15

V

Valve Override Controls, 6-13

Valve Replacement, 6-11

Vent Position Sensor, 4-2

W

Water-Cooled Condenser, 2-5, 6-7

Wiring Schematic, 7-1



A member of the United Technologies Corporation family. Stock symbol UTX
©2008 Carrier Corporation • Printed in U. S. A. 02/08



Carrier

A United Technologies Company

Carrier Transicold Division,
Carrier Corporation
Container Products Group
P.O. Box 4805
Syracuse, N.Y. 13221 U.S.A

www.carrier.transicold.com