



Product Information and Technical Guide

2005 Room Air Conditioners Model Year Designation "P"

**Heavy Duty-----Example FAS155P1A
Thru-The-Wall-----Example FAH085P1T
Slider Casement---Exmample FAK104P1V**

Factory location:RK

ATTENTION SERVICERS!

To get a helping hand, visit the
Frigidaire Web Site at:
<http://www.frigidaire.com>
User name: service
Password: tips

Safety update	3
Safe Servicing Practices	4
Model Specifications	5-11
Compressor Overloads	12
Restrictor Tube Data	12
Receptacle Codes	13
Product Dimensions	14
Thermostat Diagrams	15
Fan/Blower Diagrams	16
Wiring Diagrams	17-22
Troubleshooting	23-24

TABLE OF CONTENTS

Safety Update	3
Safe Servicing Practices	4
Model Specifications	5-11
Compressor Overload Data	12
Restrictor Tube Data	12
Receptacle Outlet Codes	13
Product Dimensions	14
Control Thermostat Location Diagrams	15
2005 Heavy Duty Thermostat Locations	15
2005 Thru-The-Wall Thermostat Locations	15
2005 Slider Thermostat Locations	15
Fan and Blower Location Diagrams	16
Heavy Duty.....	16
Slider Casement.....	16
Thru-The-Wall.....	16
Wiring Diagrams	17-22
81902548.....	17
81902549	17
81902381	18
81902544.....	18
81902642.....	19
81902643.....	19
81902546.....	20
81902357.....	20
81902551.....	21
81902382.....	21
81902506	22
Troubleshooting	23-24

IMPORTANT SAFETY UPDATE

Room Air Conditioners manufactured after August 1st , 2004 are equipped with a new industry regulated power cord with either of the following in the plug-head or in line:

LCDI: Leakage Current Detection Interrupter

AFCI: Arc-Fault Circuit Interrupter.

All Frigidaire products have an LCDI located in the plug head or in-line.

The power supply cord contains a current device that senses damage to the power cord. To test your power supply cord does the following:

1. Plug in the Air Conditioner.
2. The power supply cord will have TWO buttons on the plug head. Press the TEST button. You will notice a click as the RESET button pops out.
3. Press the RESET button. Again you will notice a click as the button engages.
4. The power supply cord is now supplying electricity to the unit. (On some products this is also indicated by a light on the plug head).

Notes:

- Do not use this device to turn the unit on or off.
- Always make sure the RESET button is pushed in for correct operation.
- The power supply cord must be replaced if it fails to reset when either the TEST button is pushed, or it cannot be reset. A new one can be obtained from the product manufacturer.
- If power supply cord is damaged, it CANNOT be repaired, it MUST be replaced by one obtained from the product manufacturer.

SAFE SERVICING PRACTICES - ALL APPLIANCES

To avoid personal injury or property damage, it is important that **Safe Servicing Practices** be observed. The following are some limited examples of safe practices.

1. **DO NOT** attempt a product repair if you doubt your ability to complete it in a safe and satisfactory manner.
2. Before servicing or moving an appliance
 - Remove power cord from electrical outlet, trip circuit breaker to **OFF** position, or remove fuse
 - Turn off gas supply
 - Turn off water supply
3. Never interfere with the proper operation of any safety device.
4. **Use only OEM replacement parts cataloged for this appliance. Substitutions may defeat compliance with safety standards set for home appliances.**
5. **GROUNDING:** The standard color coding for safety ground wires is **GREEN**, or **GREEN** with **YELLOW STRIPES**. **DO NOT** use ground leads as current carrying conductors. It is **EXTREMELY** important that the service technician reestablish all safety grounds prior to completing service. Failure to do so will create an electrical hazard.
6. Prior to returning the product to service, ensure that
 - All electrical connections are correct and secure
 - All electrical leads are properly dressed and secured away from sharp edges, high-temperature components, and moving parts
 - All non-insulated electrical terminals, connectors, heaters, etc. are adequately spaced away from all metal parts and panels
 - All safety grounds (both internal and external) are correctly and securely connected
 - All panels are properly and securely reassembled.
7. In the event that the power cord is damaged, it cannot be repaired. It must be replaced with a new one from the product manufacturer.

WARNING

This service manual is intended for use by persons having electrical and mechanical training and a level of knowledge of these subjects generally considered acceptable in the appliance repair trade. Electrolux Home Products Inc. Cannot be responsible, nor assume any liability, for injury or damage of any kind arising from the use of this manual.

©2005 Electrolux Home Products, Inc.

FRIGIDAIRE MODEL SPECIFICATIONS

Model	FAS155P1A1	FAS155P1A2	FAS156P1A1	FAS156P1A2	FAS157P1A1
Chassis Type	Heavy Duty	Heavy Duty	Heavy Duty	Heavy Duty	Heavy Duty
Capacity Features BTU - Cooling BTU - Heating Moisture Removal EER	15100 - 3.5 10.7	15100 - 3.5 10.7	15100 - 3.5 10.7	15100 - 3.5 10.7	15100 - 3.5 10.7
Capacity Features Voltage Amps - Cooling Amps - Heating Watts - Cooling Watts - Heating Fuse/Breaker(Amps) Receptacle Code Power Cord Number Power Cord Amps Min Wiring Diagram Page #	115 12.3 - 1400 - 15 NEMA 5-15 KT21C7-12(U) 15 81902548 Page 17	115 12.3 - 1400 - 15 NEMA 5-15 KT21C7-12(U) 15 81902548 Page 17	115 12.3 - 1400 - 15 NEMA 5-15 KT21C7-12(U) 15 81902548 Page 17	115 12.3 - 1400 - 15 NEMA 5-15 KT21C7-12(U) 15 81902548 Page 17	115 12.3 - 1400 - 15 NEMA 5-15 KT21C7-12(U) 15 81902549 Page 17
Air Flow System Capacitor- μ Farads Fan Motor Mfg. Fan Motor Number RPM/CMP(EVAP) High Medium Low Heat Only	10/250 Heshan 81402116 900/450 - - -	10/250 Heshan 81402116 900/450 - - -	10/250 Heshan 81402116 900/450 - - -	10/250 Heshan 81402116 900/450 - - -	10/250 Heshan 81402116 900/450 - - -
Refrigeration System Compressor Mfg. Compressor Number Compressor Type Overload Protector Capacitor- μ Farads Refrigerant Charge Restrictor Tube Thermostat Type	Sanyo 1304436 Rotary MRA98693-9200 40 μ F/250V 47.3 813034550 Electronic	LG 1304559 Rotary MRA4720-12027 60 μ /250V 47.3 813034139 Electronic	Sanyo 1304436 Rotary MRA98693-9200 40 μ F/250V 47.3 813034550 Electronic	LG 1304559 Rotary MRA4720-12027 60 μ /250V 47.3 813034139 Electronic	Sanyo 1304436 Rotary MRA98693-9200 40 μ F/250V 47.3 813034550 Electronic
Installation Instructions Kit Type Part Number	A 819042102	A 819042102	A 819042102	A 819042102	A 819042102
Control Thermostat Location Diagram	Page 15	Page 15	Page 15	Page 15	Page 15
Condenser Fan and Evaporator Blower Location Diagram	Page 16	Page 16	Page 16	Page 16	Page 16

FRIGIDAIRE MODEL SPECIFICATIONS

Model	FAS157P1A2	FAS182P2A1	FAS184P2A1	FAS185P2A1	FAS186P2A1
Chassis Type	Heavy Duty	Heavy Duty	Heavy Duty	Heavy Duty	Heavy Duty
Capacity Features BTU - Cooling BTU - Heating Moisture Removal EER	15100 - 3.5 10.7	18000/17800 - 5.3 9.7	18000/17800 - 5.3 9.7	18500/18200 - 5.5 10.7	18500/18200 - 5.5 10.7
Capacity Features Voltage Amps - Cooling Amps - Heating Watts - Cooling Watts - Heating Fuse/Breaker(Amps) Receptacle Code Power Cord Number Power Cord Amps Min Wiring Diagram Page #	115 12.3 - 1400 - 15 NEMA 5-15 KT21C7-12(U) 15 81902549 Page 17	230/208 8.1/9.0 - 1850/1830 - 15 NEMA 6-15 KT21C7-13(U) 15 81902381 Page 18	230/208 8.1/9.0 - 1850/1830 - 15 NEMA 6-15 KT21C7-13(U) 15 81902544 Page 18	230/208 7.6/8.4 - 1730/1700 - 15 NEMA 6-15 KT21C7-13(U) 15 81902542 Page 19	230/208 7.6/8.4 - 1730/1700 - 15 NEMA 6-15 KT21C7-13(U) 15 81902542 Page 19
Air Flow System Capacitor- μ Farads Fan Motor Mfg. Fan Motor Number RPM/CMP(EVAP) High Medium Low Heat Only	10/250 Heshan 81402116 900/450 - - -	6 μ F/450V Heshan 8140270 1050/470 - 850/350 -	6 μ F/450V Heshan 81402117 1050/470 - 850/350 -	6 μ F/450V Heshan 81402117 1050/470 - - -	6 μ F/450V Heshan 81402117 1050/470 - - -
Refrigeration System Compressor Mfg. Compressor Number Compressor Type Overload Protector Capacitor- μ Farads Refrigerant Charge Restrictor Tube Thermostat Type	LG 1304559 Rotary MRA4720-12027 60 μ /250V 47.3 813034139 Electronic	Samsung 1304462 Rotary MRA12133-12007 35 μ F/450V 43.7 813034653 Mechanical	Samsung 1304462 Rotary MRA12133-12007 35 μ F/450V 43.7 813034653 Electronic	Samsung 1304462 Rotary MRA12133-12007 35 μ F/450V 52.2 813034653 Electronic	Samsung 1304462 Rotary MRA12133-12007 35 μ F/450V 52.2 813034653 Electronic
Installation Instructions Kit Type Part Number	A 819042102	A 819042102	A 819042102	A 819042102	A 819042102
Control Thermostat Location Diagram	Page 15	Page 15	Page 15	Page 15	Page 15
Condenser Fan and Evaporator Blower Location Diagram	Page 16	Page 16	Page 16	Page 16	Page 16

FRIGIDAIRE MODEL SPECIFICATIONS

Model	FAS187P2A1	FAS18EP2A1	FAS225P2A1	FAS226P2A1	
Chassis Type	Heavy Duty	Heavy Duty	Heavy Duty	Heavy Duty	
Capacity Features BTU - Cooling BTU - Heating Moisture Removal EER	18500/18200 - 5.5 10.7	18000/17800 16000/13000 5.5 9.7	22000/21600 - 6.5 9.4	22000/21600 - 6.5 9.4	
Capacity Features Voltage Amps - Cooling Amps - Heating Watts - Cooling Watts - Heating Fuse/Breaker(Amps) Receptacle Code Power Cord Number Power Cord Amps Min Wiring Diagram Page #	230/208 7.6/8.4 - 1730/1700 - 15 NEMA 6-15 KT21C7-13(U) 15 81902544 Page 18	230/208 8.1/9.0 19.2/21.0 1855/1840 4900/4000 30 NEMA 6-30 KT21C8-04(U) 20 81902547 Page 19	230/208 9.9/10.9 - 2340/2300 - 15 NEMA 6-15 KT21C8-03(U) 20 81902542 Page 19	230/208 9.9/10.9 - 2340/2300 - 15 NEMA 6-15 KT21C8-03(U) 20 81902542 Page 19	
Air Flow System Capacitor- μ Farads Fan Motor Mfg. Fan Motor Number RPM/CMP(EVAP) High Medium Low Heat Only	6 μ F/450V Heshan 81402117 1050/470 - - -	6 μ F/450V Heshan 81402117 1050/470 - - -	6 μ F/450V Heshan 81402117 1050/480 - - -	6 μ F/450V Heshan 81402117 1050/480 - - -	
Refrigeration System Compressor Mfg. Compressor Number Compressor Type Overload Protector Capacitor- μ Farads Refrigerant Charge Restrictor Tube Thermostat Type	Samsung 1304462 Rotary MRA12133-12007 35 μ F/450V 52.2 813034653 Electronic	Samsung 1304462 Rotary MRA12133-12007 35 μ F/450V 43.7 813034653 Electronic	LG 1304579 Rotary 3HM408 40 μ F/450V 52.9 813034888 Electronic	LG 1304579 Rotary 3HM408 40 μ F/450V 52.9 813034888 Electronic	
Installation Instructions Kit Type Part Number	A 819042102	A 819042102	A 819042102	A 819042102	
Control Thermostat Location Diagram	Page 15	Page 15	Page 15	Page 15	
Condenser Fan and Evaporator Blower Location Diagram	Page 16	Page 16	Page 16	Page 16	

FRIGIDAIRE MODEL SPECIFICATIONS

Model	FAS255P2A1	FAS256P2A1	FAS25EP2A1	FAS294P2A1	FAS296P2A1
Chassis Type	Heavy Duty	Heavy Duty	Heavy Duty	Heavy Duty	Heavy Duty
Capacity Features BTU - Cooling BTU - Heating Moisture Removal EER	25000/24700 - 7.6 9.4	25000/24700 - 7.6 9.4	25000/24700 16000/13000 7.6 9.4	28500/28000 - 8.6 8.5	28500/28000 - 8.6 8.5
Capacity Features Voltage Amps - Cooling Amps - Heating Watts - Cooling Watts - Heating Fuse/Breaker(Amps) Receptacle Code Power Cord Number Power Cord Amps Min Wiring Diagram Page #	230/208 11.4/12.6 - 2660/2630 - 20 NEMA 6-20 KT21C8-03(U) 20 81902642 Page 19	230/208 11.4/12.6 - 2660/2630 - 20 NEMA 6-20 KT21C8-03(U) 20 81902642 Page 19	230/208 11.4/12.6 19.2/21.0 2660/2630 4900/4000 30 NEMA 6-30 KT21C8-04(U) 20 81902643 Page 19	230/208 14.4/15.9 - 3350/3300 - 30 NEMA 6-30 KT21C8-04(U) 20 81902546 Page 20	230/208 14.4/15.9 - 3350/3300 - 30 NEMA 6-30 KT21C8-04(U) 20 81902546 Page 20
Air Flow System Capacitor- μ Farads Fan Motor Mfg. Fan Motor Number RPM/CMP(EVAP) High Medium Low Heat Only	6 μ F/450V Heshan 81402117 1050/480 - - -	6 μ F/450V Heshan 81402117 1050/480 - - -	6 μ F/450V Heshan 81402117 1050/480 - - -	7.5 μ F/450V Heshan 81402118 1150/500 - - -	7.5 μ F/450V Heshan 81402118 1150/500 - - -
Refrigeration System Compressor Mfg. Compressor Number Compressor Type Overload Protector Capacitor- μ Farads Refrigerant Charge Restrictor Tube Thermostat Type	Samsung 1304606 Rotary 3HM208-41 50 μ F/400V 50.0 813034709/10* Electronic	Samsung 1304606 Rotary 3HM208-41 50 μ F/400V 50.0 813034709/10* Electronic	Samsung 1304606 Rotary 3HM208-41 50 μ F/400V 50.0 813034709/10* Electronic	Samsung 1304608 Rotary 3HM535-41 50 μ F/400V 48.7 813034751-54# Electronic	Samsung 1304608 Rotary 3HM535-41 50 μ F/400V 48.7 813034751-54# Electronic
Installation Instructions Kit Type Part Number	A 819042102	A 819042102	A 819042102	A 819042102	A 819042102
Control Thermostat Location Diagram	Page 15	Page 15	Page 15	Page 15	Page 15
Condenser Fan and Evaporator Blower Location Diagram	Page 16	Page 16	Page 16	Page 16	Page 16

* Restrictor tube part numbers: 813034709 & 813034710.

Restrictor tube part numbers: 813034751, 813034752, 813034753 & 813034754.

FRIGIDAIRE MODEL SPECIFICATIONS

Model	FAK085P7V1	FAK104P1V1	FAK107P1V1	FAK124P1V1	FAK127P1V1
Chassis Type	Slider Casement	Slider Casement	Slider Casement	Slider Casement	Slider Casement
Capacity Features					
BTU - Cooling	8000	10000	10000	12000	12000
BTU - Heating	-	-	-	-	-
Moisture Removal	6.5	6.5	6.5	6.5	6.5
EER	10.5	9.5	9.5	9.5	9.5
Capacity Features					
Voltage	115	115	115	115	115
Amps - Cooling	7.3	9.6	9.6	11.2	11.2
Amps - Heating	-	-	-	-	-
Watts - Cooling	760	1050	1050	1260	1260
Watts - Heating	-	-	-	-	-
Fuse/Breaker(Amps)	15	15	15	15	15
Receptacle Code	NEMA 5-15	NEMA 5-15	NEMA 5-15	NEMA 5-15	NEMA 5-15
Power Cord Number	KT21C6-27(U)	KT21C6-27(U)	KT21C6-27(U)	KT21C7-12(U)	KT21C7-12(U)
Power Cord Amps Min	13	13	13	15	15
Wiring Diagram	81902357	81902357	81902357	81902357	81902357
Page #	Page 20	Page 20	Page 20	Page 20	Page 20
Air Flow System					
Capacitor- μ Farads	8 μ F/250V	8 μ F/250V	8 μ F/250V	8 μ F/250V	8 μ F/250V
Fan Motor Mfg.	Heshan	Heshan	Heshan	Heshan	Heshan
Fan Motor Number	8140296	8140262	8140262	8140262	8140262
RPM/CMP(EVAP)					
High	1280/210	1380/270	1380/270	1380/270	1380/270
Medium	1100/190	1200/245	1200/245	1200/245	1200/245
Low	1000/160	1050/205	1050/205	1050/205	1050/205
Heat Only	-	-	-	-	-
Refrigeration System					
Compressor Mfg.	Panasonic	LG	LG	LG	LG
Compressor Number	1304599	1304443	1304443	1304447	1304447
Compressor Type	Rotary	Rotary	Rotary	Rotary	Rotary
Overload Protector	MRA98503or 98706	MRA12061-12026	MRA12061-12026	MRA12053-12027	MRA12053-12027
Capacitor- μ Farads	35 μ F/250V	50 μ F/250V	50 μ F/250V	50 μ F/250V	50 μ F/250V
Refrigerant Charge	21.9	23.3	23.3	23.3	23.3
Restrictor Tube	813034688/ 813035382	813032374	813032374	813034472/8130 34774/813034775	813034472/8130 34774/813034775
Thermostat Type	Electronic	Electronic	Electronic	Electronic	Electronic
Installation Instructions					
Kit Type	V	V	V	V	V
Part Number	819042237	819042237	819042237	819042237	819042237
Control Thermostat					
Location Diagram	Page 15	Page 15	Page 15	Page 15	Page 15
Condenser Fan and					
Evaporator Blower					
Location Diagram	Page 16	Page 16	Page 16	Page 16	Page 16

FRIGIDAIRE MODEL SPECIFICATIONS

Model	FAH085P1T1	FAH08EP1T1	FAH105P1T1	FAH105P2T1	
Chassis Type	Thru-the-wall	Thru-the-wall	Thru-the-wall	Thru-the-wall	
Capacity Features BTU - Cooling BTU - Heating Moisture Removal EER	8000 - 1.8 9.4	8000 4000 1.8 9.4	10000 - 2.8 9.4	10000/9800 - 2.8 9.4	
Capacity Features Voltage Amps - Cooling Amps - Heating Watts - Cooling Watts - Heating Fuse/Breaker(Amps) Receptacle Code Power Cord Number Power Cord Amps Min Wiring Diagram Page #	115 7.4 - 850 - 15 NEMA 5-15 KT21C7-15(U) 15 81902357 Page 20	115 7.4 11.2 850 1250 15 NEMA 5-15 KT21C7-15(U) 15 81902551 Page 21	115 9.5 - 1065 - 15 NEMA 5-15 KT21C7-15(U) 15 81902357 Page 20	230/208 4.8/5.5 - 1065/1040 - 15 NEMA 6-15 KT21C7-14(U) 15 81902382 Page 21	
Air Flow System Capacitor- μ Farads Fan Motor Mfg. Fan Motor Number RPM/CMP(EVAP) High Medium Low Heat Only	12uF/450V Heshan 8140297 1010/280 910/240 810/205 -	12uF/450V Heshan 8140297 1010/280 910/240 810/205 -	12uF/450V Heshan 8140297 1010/250 910/220 810/185 -	3.5uF/450V Heshan 8140298 1010/250 910/220 810/185 -	
Refrigeration System Compressor Mfg. Compressor Number Compressor Type Overload Protector Capacitor- μ Farads Refrigerant Charge Restrictor Tube Thermostat Type	Hili 1304607 Rotary MRA98883-9200 50 μ F/250V 20.5 813034737 Electronic	Hili 1304607 Rotary MRA98883-9200 50 μ F/250V 20.5 813034737 Electronic	LG 1304443 Rotary MRA12061-12026 50 μ F/250V 24.7 813034403 Electronic	LG 1304564 Rotary MRA12054-12026 30 μ F/450V 24.7 813034747 Electronic	
Installation Instructions Kit Type Part Number	T 819042236	T 819042236	T 819042236	T 819042236	
Control Thermostat Location Diagram	Page 15	Page 15	Page 15	Page 15	
Condenser Fan and Evaporator Blower Location Diagram	Page 16	Page 16	Page 16	Page 16	

FRIGIDAIRE MODEL SPECIFICATIONS

Model	FAH10EP2T1	FAH125P2T1	FAH12EP2T1		
Chassis Type	Thru-the-wall	Thru-the-wall	Thru-the-wall		
Capacity Features BTU - Cooling BTU - Heating Moisture Removal EER	10000/9800 10000/8500 2.8 9.4	12000/11750 - 3.6 9.4	12000/11700 10000/8500 3.6 9.4		
Capacity Features Voltage Amps - Cooling Amps - Heating Watts - Cooling Watts - Heating Fuse/Breaker(Amps) Receptacle Code Power Cord Number Power Cord Amps Min Wiring Diagram Page #	230/208 4.8/5.5 13.2/12.0 1065/1040 3050/2500 15 NEMA 6-15 KT21C7-14(U) 15 81902506 Page 22	230/208 5.9/6.4 - 1275/1250 - 15 NEMA 6-15 KT21C7-14(U) 15 81902382 Page 21	230/208 5.9/6.4 13.7/12.7 1275/1250 3120/2600 15 NEMA 6-15 KT21C7-14(U) 15 81902506 Page 22		
Air Flow System Capacitor- μ Farads Fan Motor Mfg. Fan Motor Number RPM/CMP(EVAP) High Medium Low Heat Only	3.5 μ F/450V Heshan 8140298 1010/250 910/220 810/185 -	3.5 μ F/450V Heshan 8140298 1010/260 910/230 810/195 -	3.5 μ F/450V Heshan 8140298 1010/260 910/230 810/195 -		
Refrigeration System Compressor Mfg. Compressor Number Compressor Type Overload Protector Capacitor- μ Farads Refrigerant Charge Restrictor Tube Thermostat Type	LG 1304564 Rotary MRA12054-12026 30 μ F/450V 24.7 813034747 Electronic	LG 1304580 Rotary MRA12124-12026 30 μ F/450V 26.1 813034230 Electronic	LG 1304580 Rotary MRA12124-12026 30 μ F/450V 26.1 813034230 Electronic		
Installation Instructions Kit Type Part Number	T 819042236	T 819042236	T 819042236		
Control Thermostat Location Diagram	Page 15	Page 15	Page 15		
Condenser Fan and Evaporator Blower Location Diagram	Page 16	Page 16	Page 16		

Compressor Overload Data					
Supplier Part#	Used With Compressor	Opening Temp °C	Closing Temp °C	Short Time Tripat 25°C	
				Test Amp	Opeing Time-Sec
MRA98693-9200	QXE-19(F)	165±5	69±11	43.0	11±5
MRA4720-12027	QK208CAA	150±5	69±11	50.3	7±5
MRA12133-12007	48D172IUAEL	150±5	75±11	26.0	11±5
3HM408	QP306KBB	165±5	97±11	54.0	10±5
3HM208-41	55A260IU2JM	165±5	90±11	59.0	3~10
3HM535-41	55A300IU1JM	165±5	92±11	67.0	10±5
MRA98503or 98706	2R12S3R126AUB	160±5	80±11	26.0	11±5
MRA12061-12026	QK141CCD	150±5	61±11	40.5	11±5
MRA12053-12027	QK164CBF	150±5	61±11	41.5	11±5
MRA98883-9200	SD104SW-P3AU	160±5	70±11	25.0	11±5
MRA12054-12026	QK141KBH	155±7	69±11	14.5	11±5
MRA12124-12026	QK164KBK	145±5	69±11	19.0	11±5

*Terminal to overload must withstand 10 pounds pull test.

Restrictor Tube Data							
Style#	Length	O.D.	I.D.	Mpa	CFM Dry Air		
					Minimum	Maximum	
813034550	800	0.106	0.055	0.7	1.809	1.901	
813034139	800	0.106	0.055	0.7	1.809	1.901	
813034653	550	0.106	0.039	0.7	0.910	1.005	
813034888	400	0.106	0.039	0.7	1.007	1.095	
813034709	1000	0.106	0.047	0.7	1.148	1.289	
813034710	850	0.106	0.047	0.7	1.205	1.298	
813034751	450	0.106	0.039	0.7	0.873	0.958	
813034752	650	0.106	0.039	0.7	0.852	0.946	
813034753	650	0.106	0.039	0.7	0.852	0.946	
813034754	650	0.106	0.039	0.7	0.852	0.946	
813034688	600	0.106	0.039	0.7	0.869	0.950	
813035382	520	0.106	0.039	0.7	0.933	1.021	
813032374	400	0.106	0.039	0.7	1.007	1.095	
813034472	1100	0.106	0.039	0.7	0.675	0.756	
813034774	800	0.106	0.039	0.7	0.781	0.865	
813034775	950	0.106	0.039	0.7	0.735	0.817	
813034737	600	0.106	0.039	0.7	0.887	0.961	
813034403	550	0.106	0.039	0.7	0.912	1.007	
813034747	550	0.106	0.039	0.7	0.912	1.007	
813034230	500	0.106	0.039	0.7	0.936	1.025	

Receptacle Outlet Codes

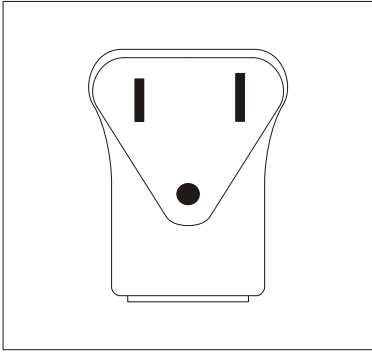

115 Volts-15Amps
NEMA 5-15 TYPE

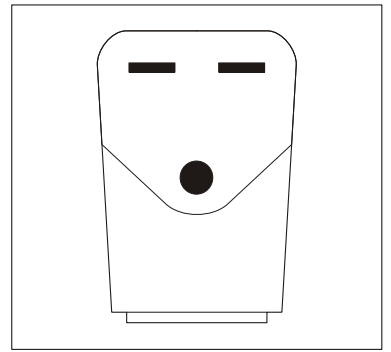

230 Volts-15Amps
NEMA 6-15 TYPE

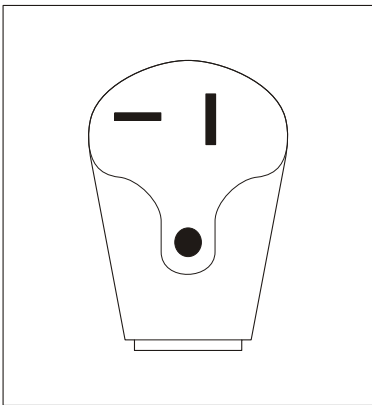

230 Volts-20Amps
NEMA 6-20 TYPE

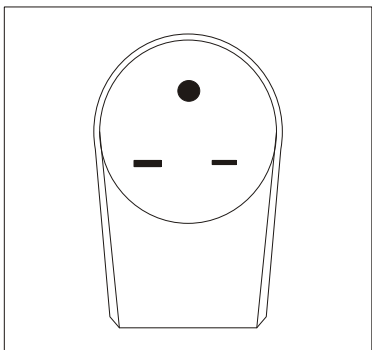

230 Volts-30Amps
NEMA 6-30 TYPE

Power Supply Cord with
3-prong Grounding Plug

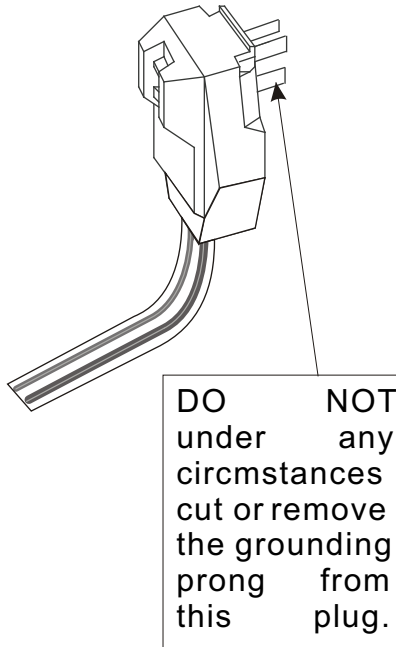

DO NOT
under any
circmstances
cut or remove
the grounding
prong from
this plug.

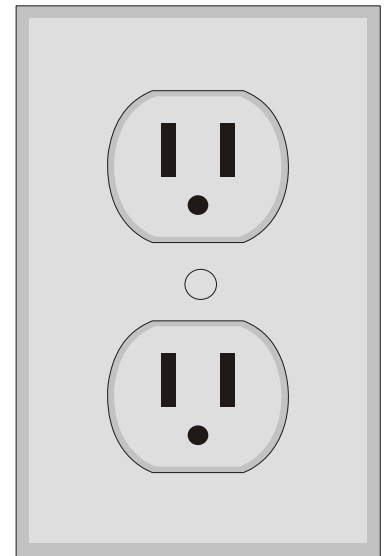

Grounding Type
Wall Receptacle

Product Dimensions

Heavy Duty Slide Out Top Control
Top Air Discharge

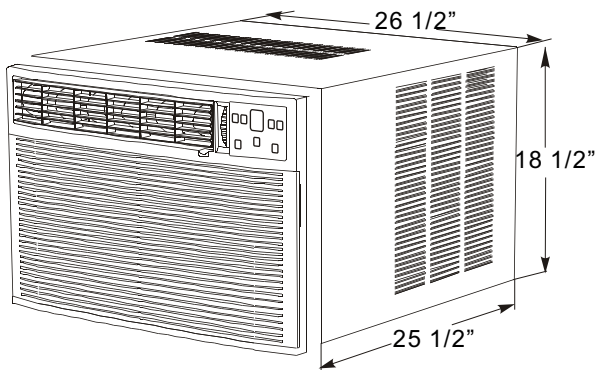

Maximum Wall Thickness 9"

Slider Casement

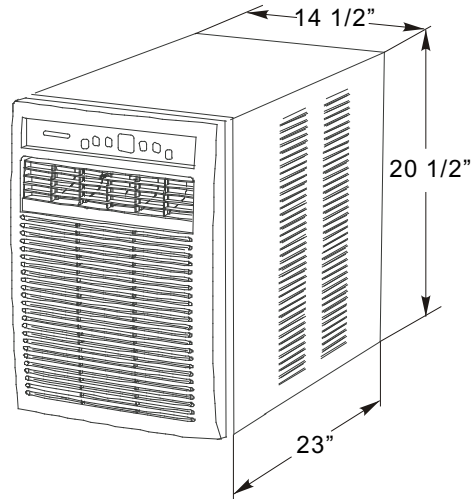

Thru The Wall
No Side Louvers

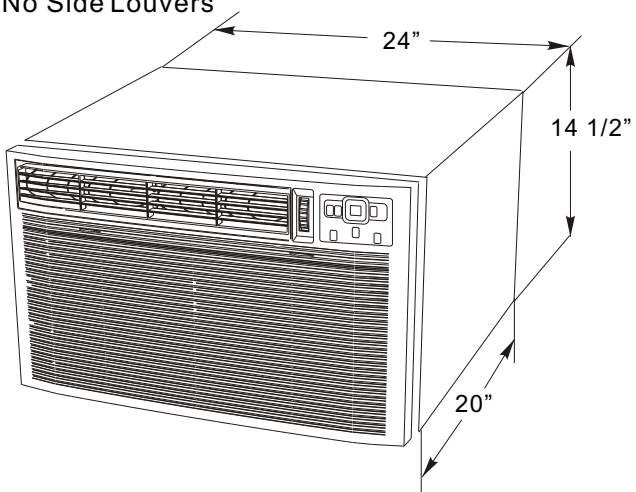

Maximum Wall Thickness 22"

Thermostat Diagrams

Heavy Duty Electric Model

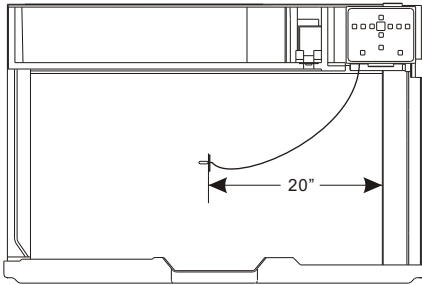

Air thermistor and thermistor holder

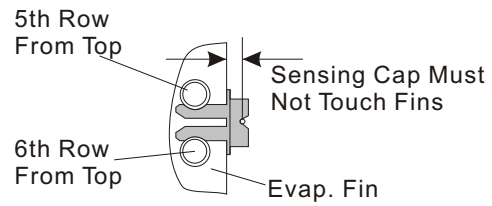

Side View

Heavy Duty Rotary Model

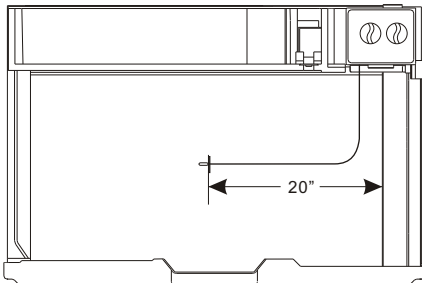

Air thermostat and thermostat holder

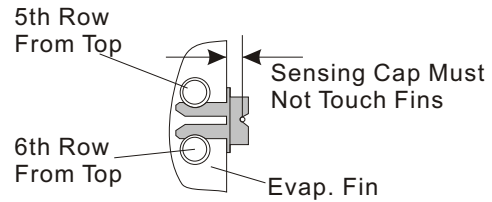

Side View

Thru The Wall

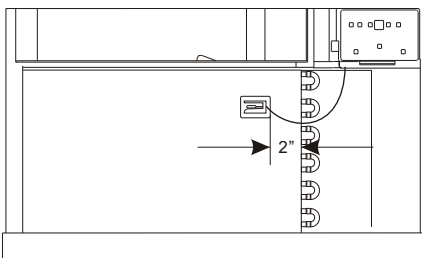

Air thermistor and thermistor holder
(Place between 3th and 4th rows tubes up from the top.)

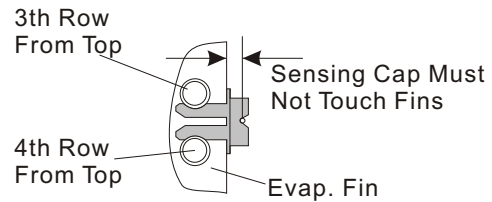

Side View

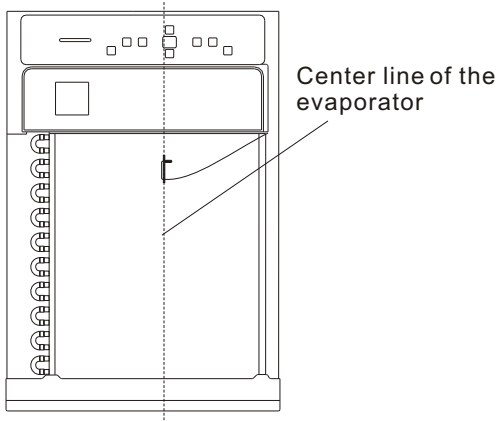

Air thermistor and thermistor holder
(Place between 3th and 4th rows tubes up from the top.)

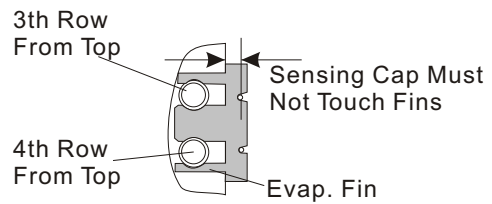

Side View

Fan and Blower Location Diagrams

Heavy Duty Top Control

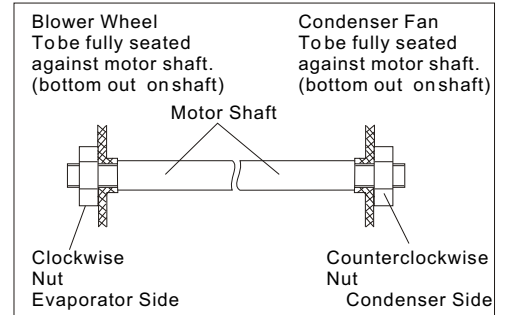
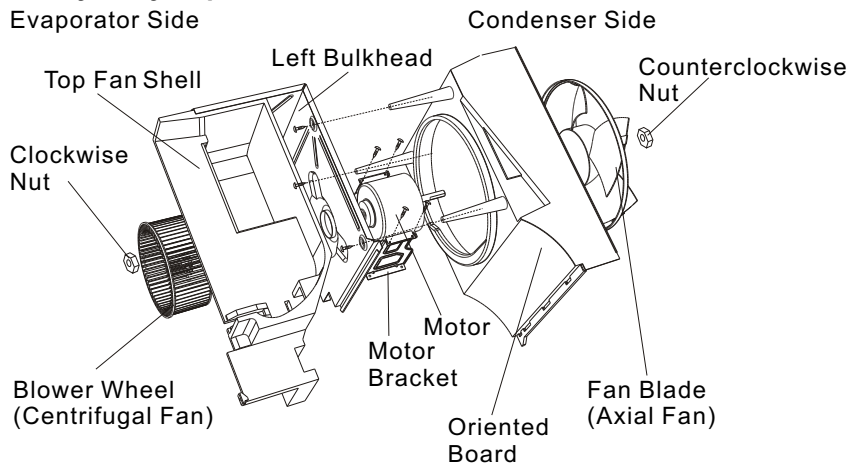

Slider Casement

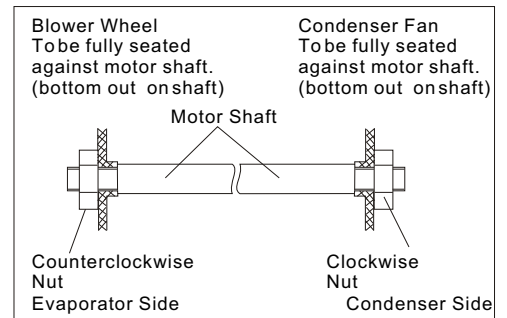
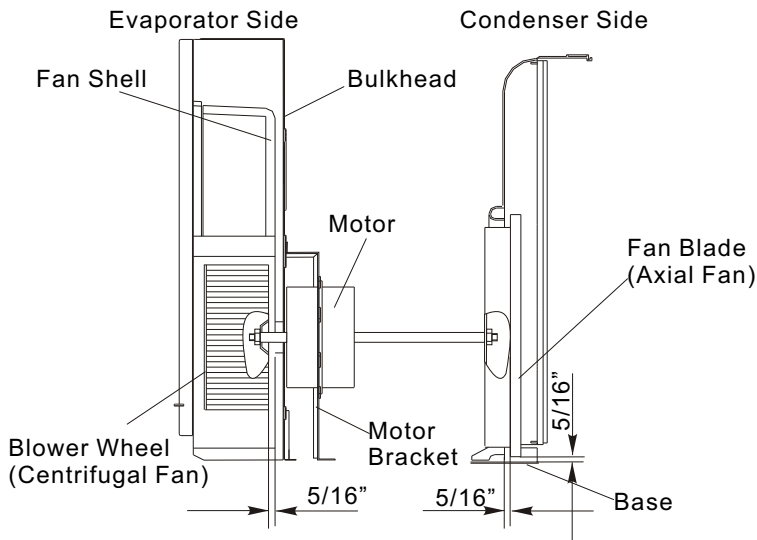

Thru The Wall

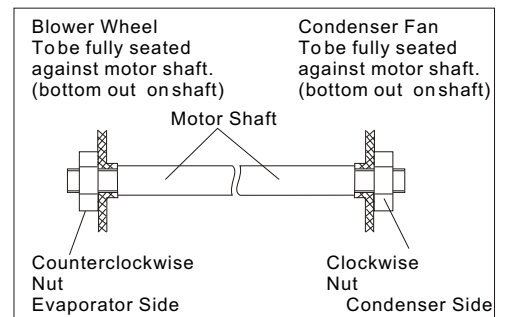
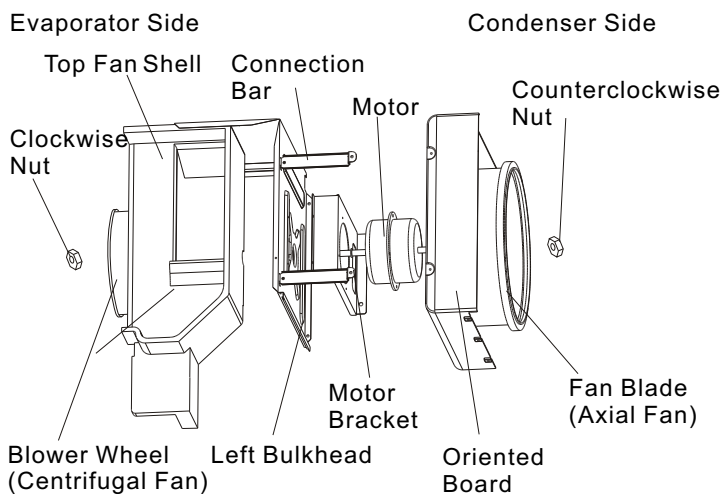

Wiring Diagrams

81902548

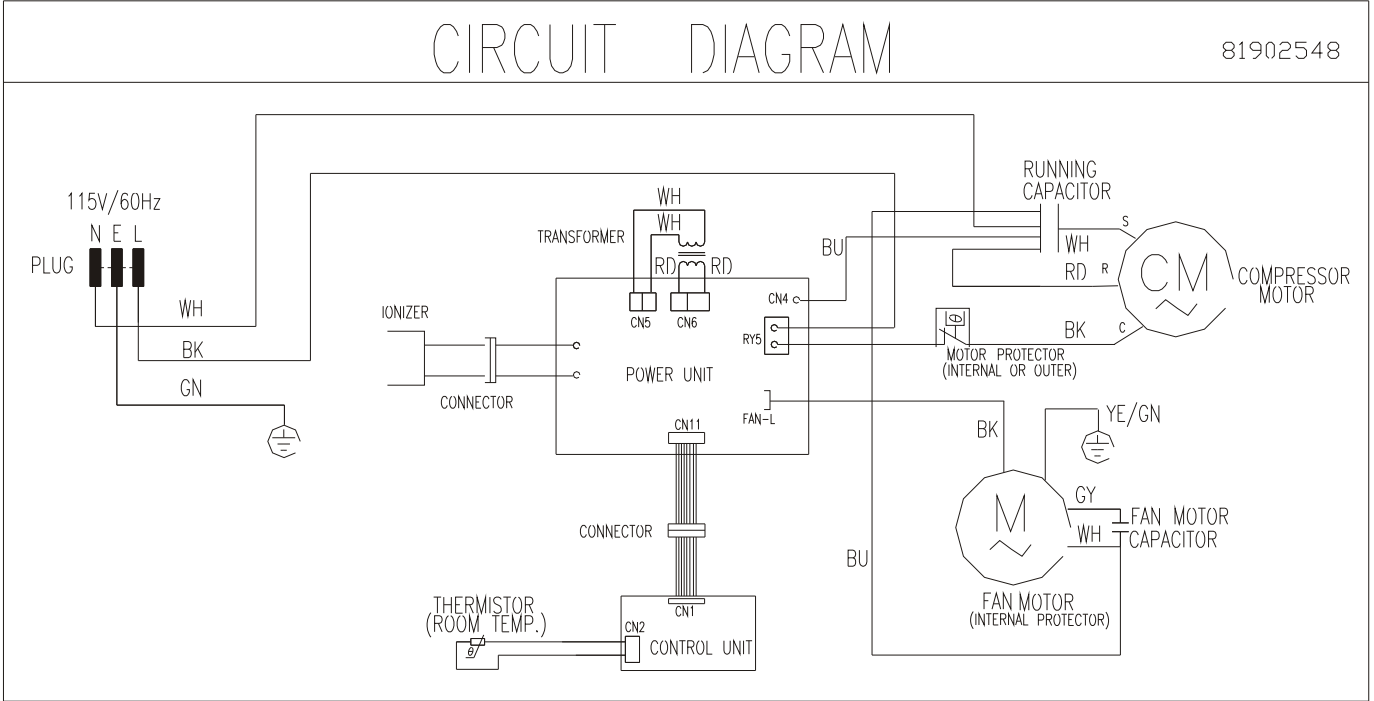

81902549

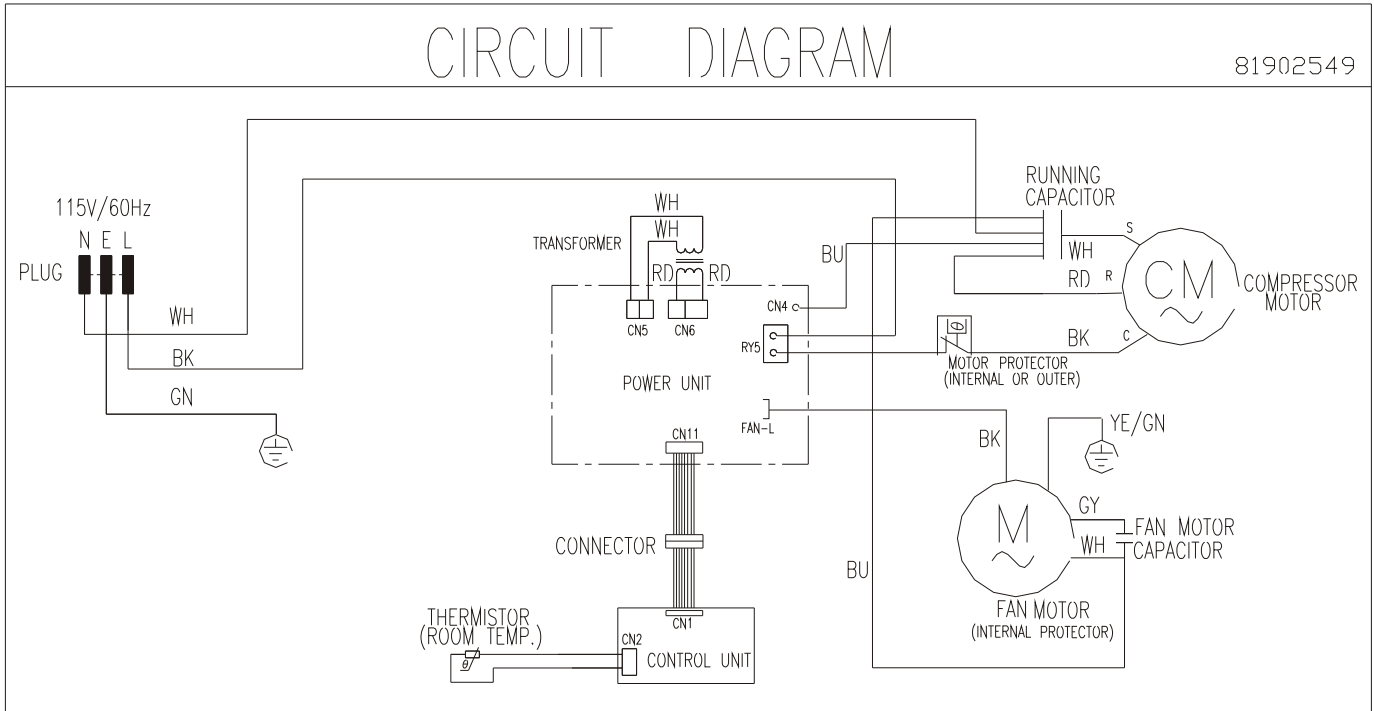

Wiring Diagrams

81902381

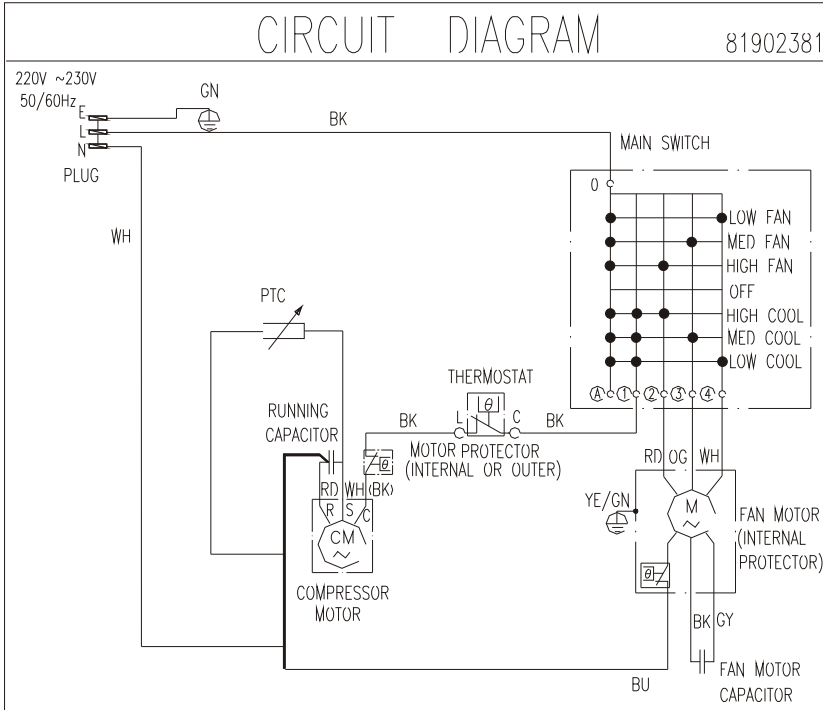

81902544

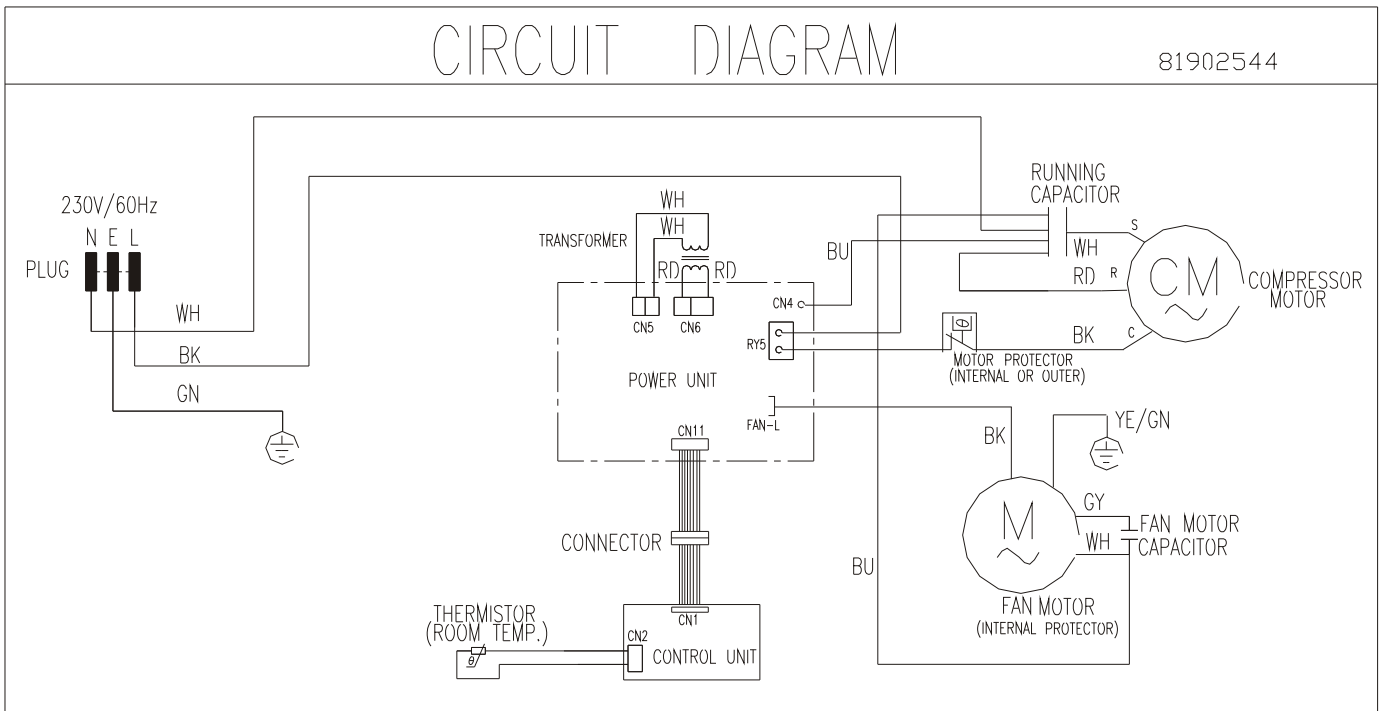

Wiring Diagrams

81902642

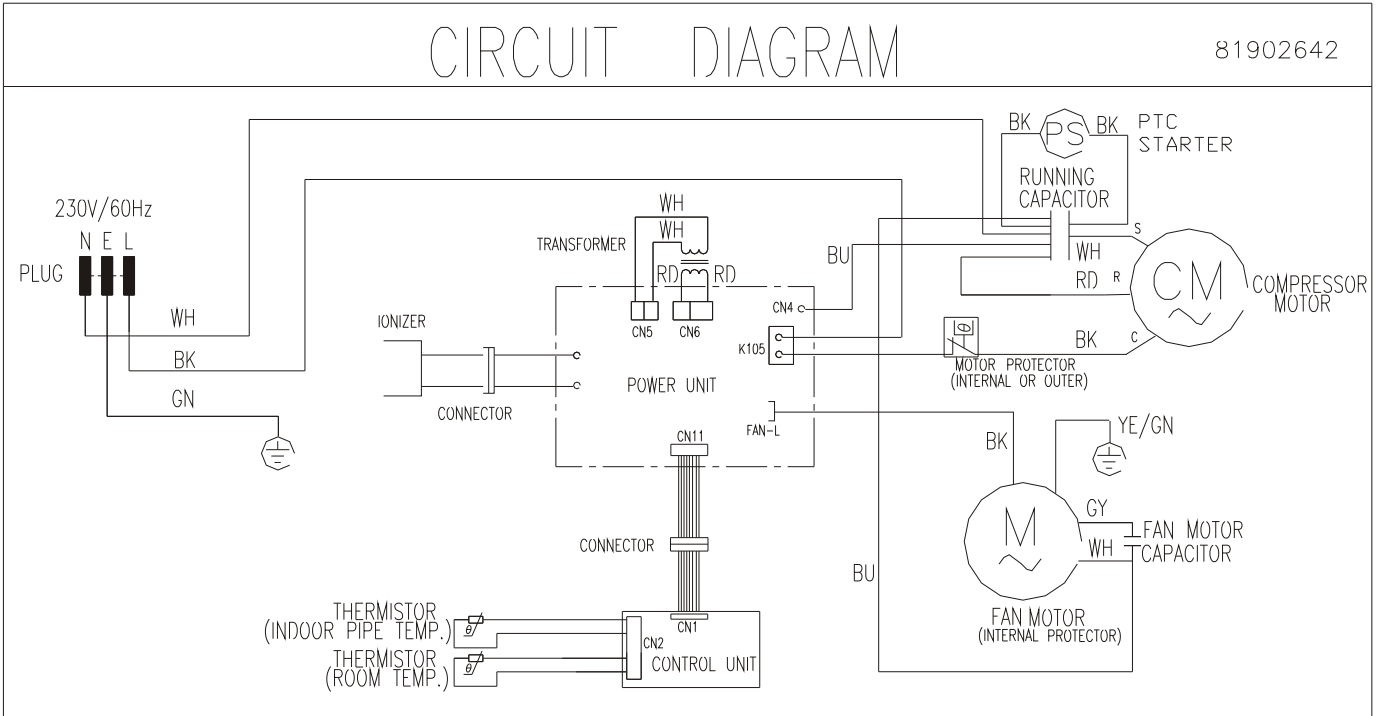

81902643

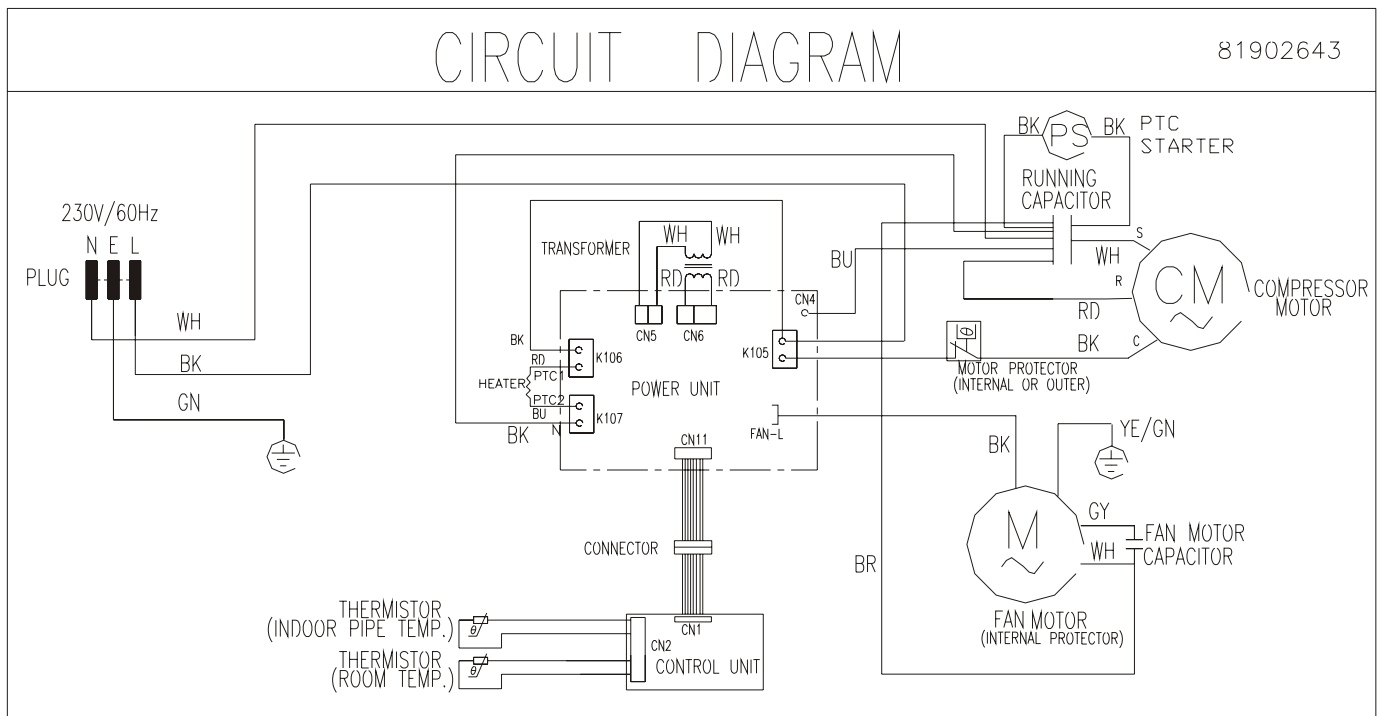

Wiring Diagrams

81902546

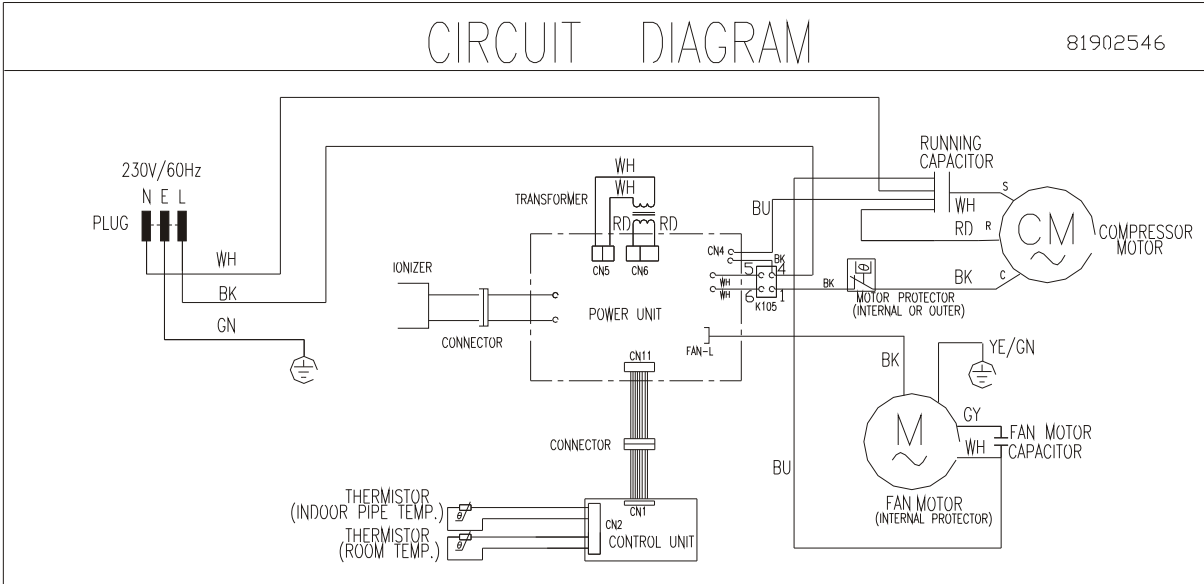

81902357

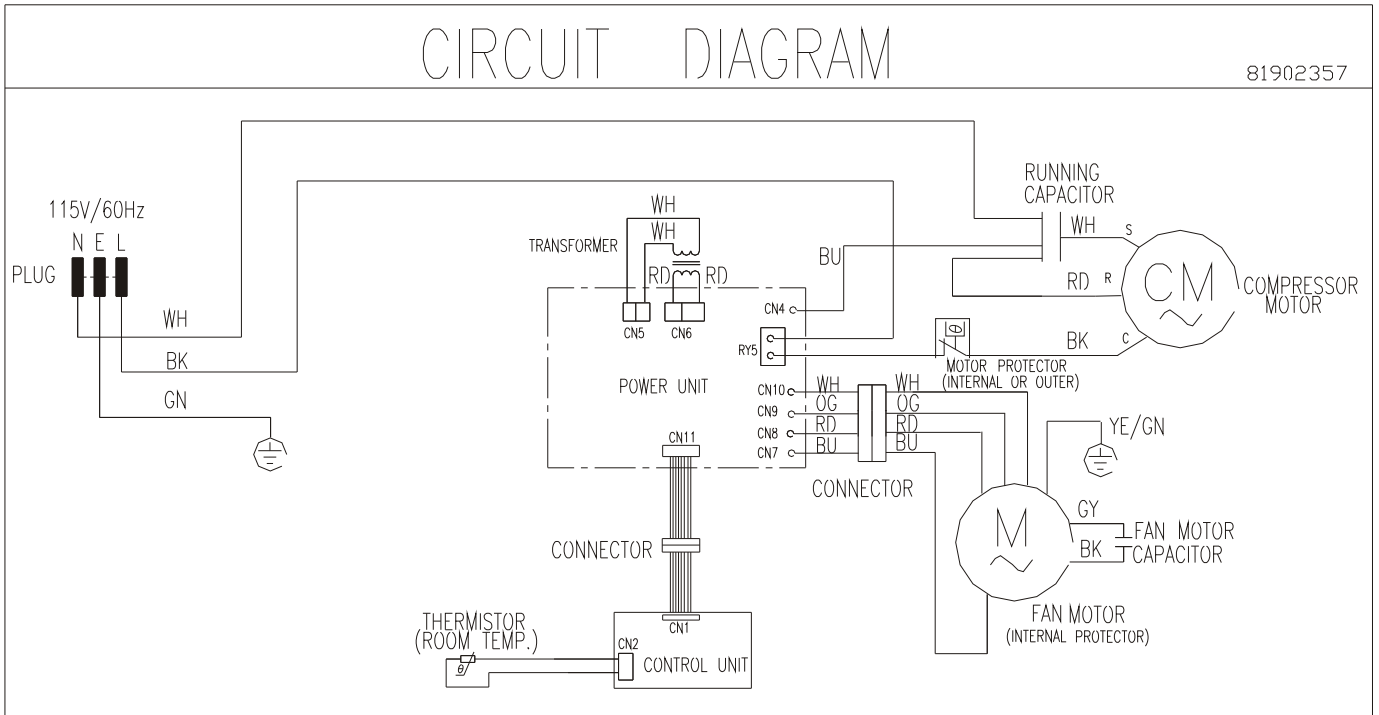

Wiring Diagrams

81902551

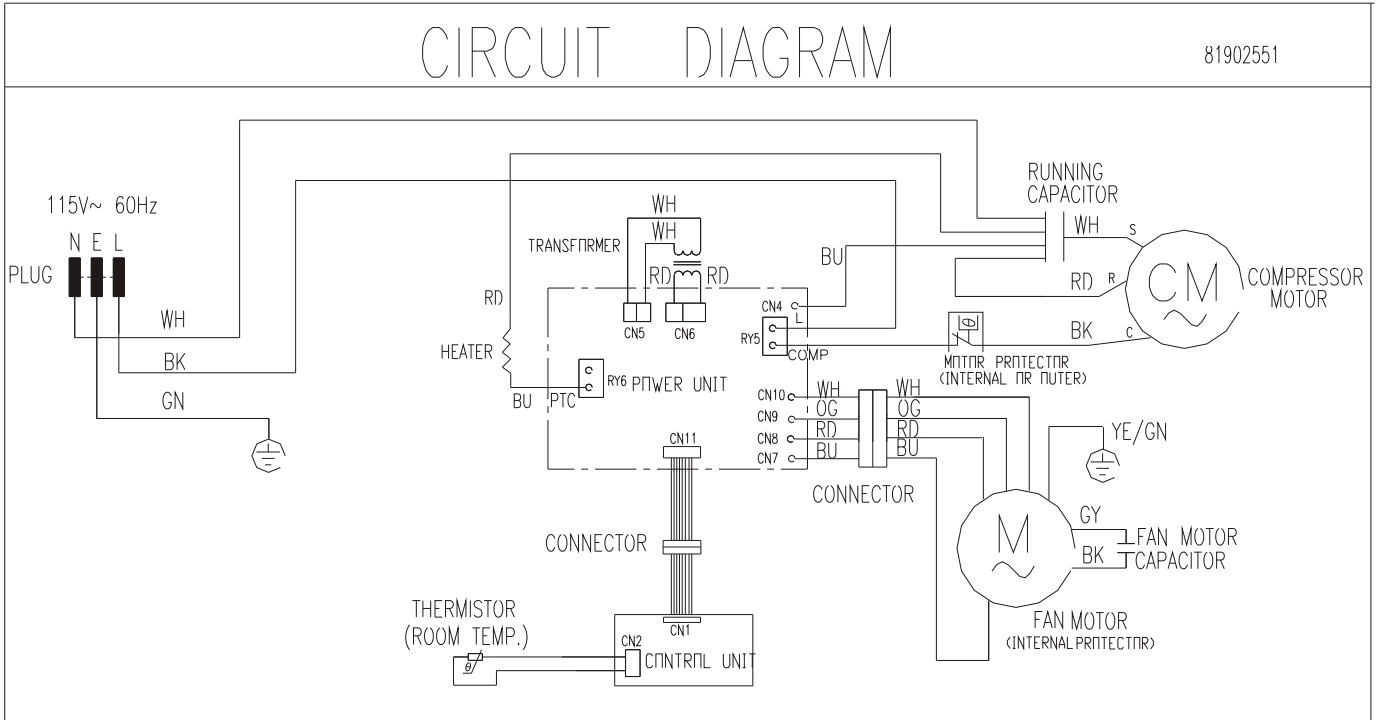

81902382

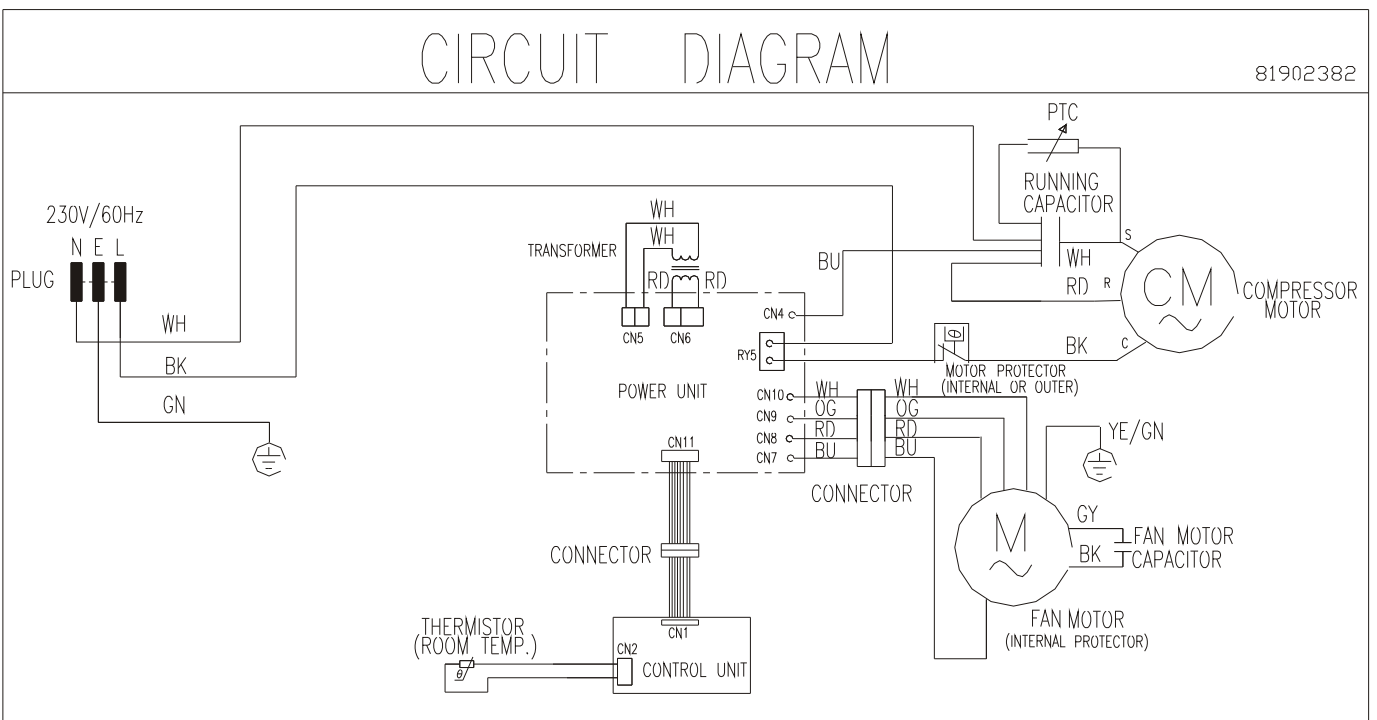

Wiring Diagrams

81902506

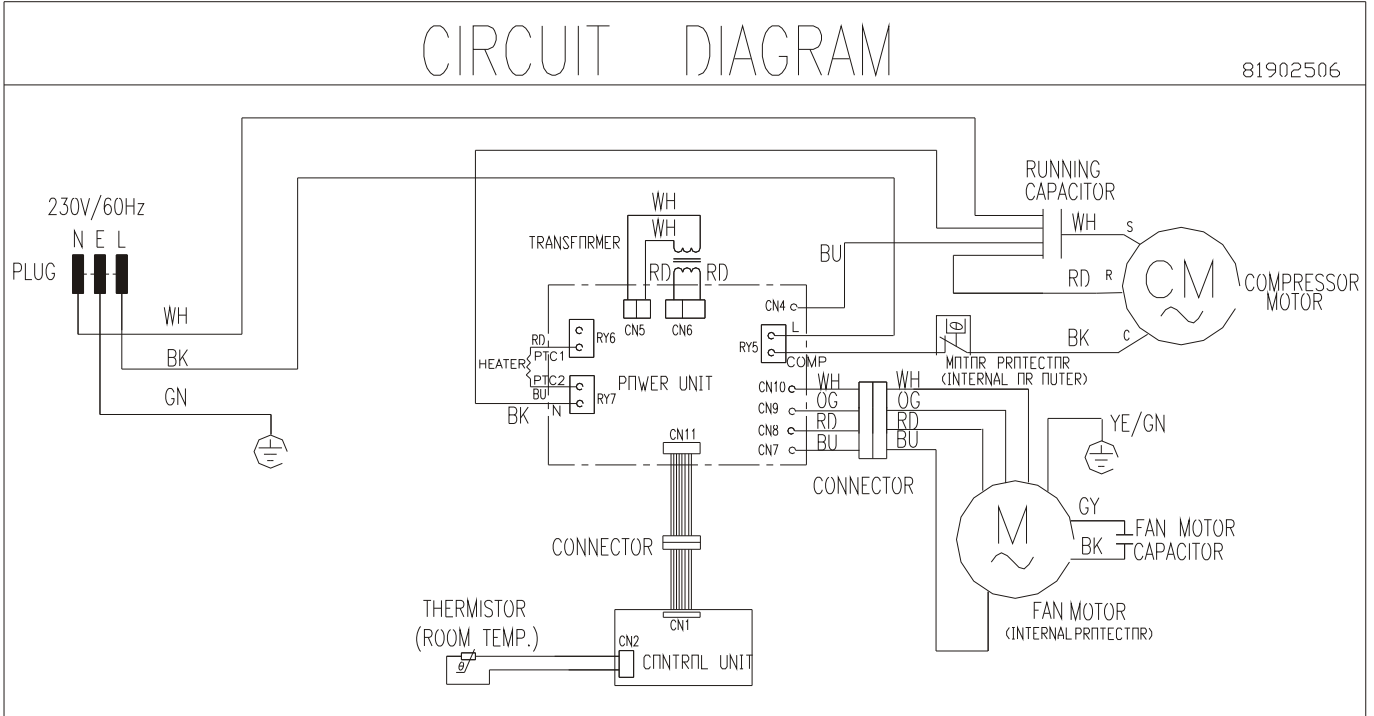

ROOM AIR CONDITIONERS TROUBLESHOOTING

CAUTION: Review Safe Servicing Practices in the front of this manual before attempting diagnostic procedures and repairs.

AIR CONDITIONER VOLTAGE LIMITS

NAMEPLATE RATING	MINIMUM	MAXIMUM
115VAC	103.5VAC	126.5VAC
230VAC	207VAC	253VAC
208/230VAC	197.5VAC	253VAC

AIR CONDITIONER VOLTAGE LIMITS

Low voltage is a common cause of trouble in the operation of any room air conditioner.

Improper voltage may cause one or more of the following problems:

1. Unit will not start.
2. Compressor motor cycling on motor protector.
3. Premature failure of motor protector.
4. Blown fuses.
5. Premature failure of compressor or fan motor.
6. Noticeable dimming of lights when air conditioner is running.
7. Evaporator icing. Low voltage may reduce fan speed resulting in inadequate air flow over evaporator, thereby allowing it to ice up.

Low voltage can also be the direct result of inadequately wired circuits, extension cords, or loose fuses and connections to the power supply. Voltage may also be a general condition in the area (a responsibility of the power company).

All units will start and run on the minimum voltage stated in the chart to the left, and will perform satisfactorily if the voltage remains constant. Low voltage caused by defective wiring will not remain constant under load.

To test for low voltage, use a reliable meter with sufficient capacity to measure the required voltage. Take measurements at the electric power entry point and at the electric outlet serving the air conditioner. Take readings with the unit off, while the unit is starting, and again while the unit is running. The lowest reading should not drop below the lowest value listed in the chart.

HIGH VOLTAGE

High voltage can be equally troublesome, causing motors to overheat, cycle on their protectors, or break down electrically. This problem can only be solved by the power company.

ELECTRONIC CONTROL

This control is not repairable. If any component in the control is defective, the entire control must be replaced.

IMPORTANT NOTICE: Repair or replace any malfunctioning line voltage component before testing or replacing the electronic control. **DO NOT** assume a service problem is directly caused by the electronic control system. A line voltage component (including power cord and wiring) that has opened, shorted, grounded or otherwise malfunctioned, may have created a service problem.

SYMPTON

Fan motor will not run.

POSSIBLE CAUSE

1. No power.
2. Power supply cord.
3. Selector switch.
4. Energy saving switch (if applicable).
5. Electronic control (if applicable).
6. Wire disconnected or connection loose.
7. Capacitor. (Discharge capacitor before testing.)
8. Defective fan motor windings.
9. Will not rotate. Fan blade hitting shroud or blower wheel hitting scroll. (Motor cycles on overload.)

Fan motor runs intermittently.

1. Cycle on motor protector.

Fan motor noisy.

1. Condenser fan blade or evaporator blower wheel.
2. Loose power clamp or setscrew.
3. Worn bearings.
4. Grommets (if applicable).

SYMPTON

POSSIBLE CAUSE

Compressor will not run, but fan motor runs.	<ol style="list-style-type: none">1. Voltage.2. Wiring.3. Selector switch.4. Temperature control.5. Capacitor. (Discharge capacitor before testing.)6. Compressor.7. Motor protector(external).8. Motor protector(internal).9. Electronic control(if applicable).10. Hard starting.
Compressor cycles on motor protector.	<ol style="list-style-type: none">1. Voltage.2. Motor protector(external).3. Motor protector(internal).4. Fan motor.5. Condenser air flow restriction.6. Condenser fins damaged.7. Capacitor.8. Wiring.9. Refrigerant system.
Insufficient cooling.	<ol style="list-style-type: none">1. Low capacity.2. Air filter.3. Exhaust door open.4. Unit undersized.
Excessive noise.	<ol style="list-style-type: none">1. Evaporator blower wheel.2. Condenser wheel.3. Copper tubing.4. Compressor internal noise.5. Fan motor.
Excessive water or condensation.	<ol style="list-style-type: none">1. Unit operating under extremely high humidity conditions.
No cooling.	<ol style="list-style-type: none">1. Refrigerant leak.
Unit is cooling but room is not cool.	<ol style="list-style-type: none">1. Amps and watts.2. Sealed refrigeration system.
Wattage decreases slowly until abnormally low.	<ol style="list-style-type: none">1. Undercharged, restricted strainer or plugged restrictor tube.
Wattage decreases immediately.	<ol style="list-style-type: none">1. No refrigerant2. Compressor defective.
Wattage continues high.	<ol style="list-style-type: none">1. Refrigerant overcharge.
Evaporator coil partially frosted.	<ol style="list-style-type: none">1. System low on refrigerant.
Evaporator completely iced.	<ol style="list-style-type: none">1. Low outside temperature.
No heat.	<ol style="list-style-type: none">1. No power.2. Selector switch position.3. Temperature control position.4. Fan motor.5. Heating element.6. Selector switch.7. Temperature control.8. Terminals and connectors.
Fan motor will not rotate during heat cycle. (Heat/Cool models only.)	<ol style="list-style-type: none">1. Thermostatic drain valve.(what level control, if applicable.)