



LINE CONDITIONERS

USER'S GUIDE

PE 1411/10 (9415 014 11 101)
PE 1411/15 (9415 014 11 151)
PE 1411/20. (9415 014 11 201)
(9415 014 11 202)
(9415 014 11 203)
(9415 014 11 204)

PE 1414/10 (9415 014 14 101)
PE 1414/15 (9415 014 14 151)
PE 1414/20. (9415 014 14 201)
(9415 014 14 202)
(9415 014 14 203)
(9415 014 14 204)

PE 1412/10 (9415 014 12 101)
PE 1412/15 (9415 014 12 151)
PE 1412/20. (9415 014 12 201)
(9415 014 12 202)
(9415 014 12 203)
(9415 014 12 204)

PE 1413/10 (9415 014 13 101)
PE 1413/15 (9415 014 13 151)
PE 1413/20. (9415 014 13 201)
(9415 014 13 202)
(9415 014 13 203)
(9415 014 13 204)

ELECTROTECHNISCHE INDUSTRIE ETI B.V.

Postbus 56, 7120 AB Aalten - NL
Vierde Broekdijk 16, 7122 JD Aalten - NL
Telefoon (0543) 47 24 31
Fax (0543) 47 54 25

CONTENTS	2
LIST OF FIGURES	2
ABBREVIATIONS	2
SAFETY PRECAUTIONS	3
SYMBOLS	
IMPAIRED SAFETY PROTECTION	
IMPORTANT	
WARNINGS	
WARNING A	
WARNING B	
WARNING C	
UNPACKING	
WARNING D	
GENERAL	4
1. INTRODUCTION	
2. CHARACTERISTICS	
2.1 ELECTRICAL DATA	
2.1.1 GENERAL	
2.1.2 INPUT	
2.1.3 OUTPUT	
2.1.4 OUTPUT EFFECTS	
2.1.4.1 AS FILTER	4
2.1.4.1 AS STABILIZER	4
2.1.5 PROTECTION	5
2.2 ENVIRONMENTAL DATA	
2.2.1 CLIMATIC CONDITIONS	
2.2.2 ENVIRONMENTAL TESTS	
2.3 MECHANICAL DATA	
2.3.1 OVERALL DIMENSIONS AND WEIGHT	
2.3.2 MOUNTING	
2.4 ACCESSORIES	
2.4.1 OPERATING MANUAL	
DIRECTIONS FOR USE	5
3. INSTALLATION	
3.1 INITIAL INSPECTION	
3.2 MOUNTING INSTRUCTIONS	
3.3 DISMANTLING	
3.4 OUTPUT CONNECTIONS	
3.5 MAINS CONNECTION	
4 OPERATING INSTRUCTIONS	6
4.1 GENERAL INFORMATION	
4.2 SWITCHING ON	
4.3 CONTROLS, ADJUSTMENTS, INDICATORS AND TERMINALS	
4.4 SERIES, PARALLEL, THREE PHASE CONNECTIONS	
4.4.1 SERIES CONNECTION	
4.4.2 PARALLEL CONNECTION	
4.4.3 THREE PHASE CONNECTIONS	
5. ADJUSTMENTS	6
5.1 GENERAL	
5.2 MAINS INPUT	
5.3 OUTPUT ADJUSTMENTS	
6. SERVICING	
6.1 FUSE REPLACEMENT	
TABLE1 CONNECTIONS POSSIBILITIES	7

LIST OF FIGURES

FIG	P.
202 VIEW CAPACITORS (50 Hz)	8
203 VIEW CAPACITORS (60 Hz)	8
220 CONNECTIONS FILT (50 Hz)	7
221 CONNECTIONS STAB (50 Hz)	7
222 CONNECTIONS FILT (60 Hz)	7
223 CONNECTIONS STAB (60 Hz)	7
226 PARALLEL CONNECTION as Filter	8
227 PARALLEL CONNECTION as Stabilizer	8
228 THREE-PHASE CONNECTION as Filter	8
229 THREE-PHASE CONNECTION as Stabilizer	8

ABBREVIATIONS

Dm	MAINS DISTORTION
Do	OUTPUT DISTORTION
fm	MAINS FREQUENCY
G	EXTERNAL SUPPLY
Im	MAINS CURRENT
Io	OUTPUT CURRENT
Ion	NOMINAL OUTPUT CURRENT
r.m.s.	ROOT MEAN SQUARE VALUE
Ta	AMBIENT TEMPERATURE
Um	MAINS VOLTAGE
Umax	MAXIMUM OUTPUT VOLTAGE
Uo	OUTPUT VOLTAGE
Uon	NOMINAL OUTPUT VOLTAGE

SAFETY PRECAUTIONS

In the interests of safety to personnel and equipment it is strongly recommended that this page is read and thoroughly understood by all intended users before attempting to put this instrument into service.

This manual contains information and warnings which must be followed by the user to ensure safe operation and to retain the apparatus in a safe condition. Where necessary, warning and caution statements and/or symbols are marked on the apparatus.

CAUTION is used to indicate correct operating or maintenance procedures in order to prevent damage to or destruction of equipment or other property.

WARNING calls attention to a potential danger that requires correct procedures or practices in order to prevent personal injury.

SYMBOLS:



Read the operating instructions (black/yellow), see Section 4.



Protective earth (ground) terminal (black)

Any interruption of the protective conductor inside or outside the apparatus, or disconnection of the protective earth terminal is likely to make the apparatus dangerous; intentional interruption is prohibited.

IMPAIRED SAFETY PROTECTION

Whenever it is likely that safety protection has been impaired, the instrument must be made inoperative and be secured against any operation. The matter should then be referred to the appropriate servicing authority. Safety protection is likely to be impaired if, for example, the instrument fails to perform the intended measurements or shows signs of damage.

IMPORTANT WARNINGS

Wherever appropriate in the manual, four important warnings are inserted in short, reminder form to maintain subject continuity. However, if there is any doubt about their meaning, always refer to the detailed explanation below.

WARNING A:

Before any connection is made to a voltage source, the protective earth terminal shall be connected to a protective conductor. The power supply must be earthed in accordance with the IEC348 safety regulations.

When a power supply is brought from a cold to a warm environment, condensation may cause a hazardous condition : ensure therefore that the earthing requirements are strictly adhered to.

If a three-core mains cable with mains plug is used, the mains plug shall be inserted into a socket provided with a protective earth contact. The protective action shall not be negated by the use of an extension lead without protective conductor.

The cross-section of the earth conductor must be at least equal to the cross-section of the mains conductors and in accordance with the local safety regulations.

If the power supply is rack-mounted, the rack must be connected to the Safety Earth in accordance with IEC 348. The cross-section of the earth conductor must be sufficient and depending on the total power of all instruments mounted in this rack.

WARNING B:

After delivery, the apparatus must be connected to **the power source** only by a qualified person. Before making any connection, the safety measures must be thoroughly understood and observed. All adjustments, replacements, repairs, etc... shall be carried out by a qualified person aware of the hazards involved, with the instrument completely disconnected from the mains wherever possible. See IEC 950, Type A, Sec. 1.

WARNING C:

For continued protection against fire, only fuses with the required rated current and of the specified type shall be used for replacement (see section 2.1.2). The use of repaired fuses and the short circuiting of fuse holders is prohibited. The instrument shall be disconnected from all voltage sources when a fuse is to be replaced. As the power supply is electronically protected against most faults, a blown fuse indicates a major defect. Before replacing the fuse, always check the electronic circuit.

UNPACKING

On delivery, check the power supply as soon as possible to ascertain whether any damage has occurred in transit. Retain all packing materials until all items of the power supply have been accounted for and checked.

Visual inspection Carry out a mechanical check on, e.g. connectors, terminal blocks, external fuse holders and other items. Check items for dents, chips or other signs of damage. Check that all accessories are present in accordance with the accessories list (Section 2.4).

Claims In the event of obvious damage or shortages, or if the safety of the supply is suspect, a claim should be filed with the carrier immediately. ETI should also be notified in order to facilitate the repair of the instrument.

WARNING D:

If nominal values are changed, the rating type plate must be suitably amended.

GENERAL

1.INTRODUCTION

The PE 141. . /10 (open version) and PE 141. . /15 /20 (closed version) are line conditioners which deliver a sinewave output with galvanic separation between input and output. The output is short circuit proof.

NOTE : The design of this stabilizer is subject to development and improvement. Consequently, this stabilizer may incorporate minor changes in detail from the information contained in this manual. Only values with tolerances or limits can be considered as guaranteed data. Figures without tolerances are informative data without any guarantee.

2.CHARACTERISTICS

This section deals with the technical specifications of the stabilizer with regard to the input and output conditions, safety aspects and environmental and mechanical data, and gives a list of accessories that are provided with the stabilizer.

2.1 ELECTRICAL DATA

The values given in this section are valid within the rated range of operation (-10 °C to + 45 °C). On delivery, the stabilizer is adjusted at an ambient temperature of 23 °C.

2.1.1 GENERAL

* Safety In accordance with Safety Class 1 IEC 65, IEC 348, IEC 380, IEC 435.

VDE 550 : only for transformers

* Leakage current (from chassis to earth): max. 0,5 mA r.m.s. at 50 Hz (on delivery)

* Dielectric strength test .

Every unit has been factory tested to withstand the following voltages between primary and chassis 2,0 kVac.
primary and secondary 1,5 kVac.
secondary and chassis 1,5 kVac.

In the event of repetition of the dielectric strength tests, it is necessary to follow the instructions laid down in the Service Manual. If the Service Manual is not in stock ETI must be contacted in order to obtain the supplementary information.

* Output terminals : the output terminals are floating with respect to earth. The voltage between any one of the output terminals and earth may not exceed 500 Vac .(r.m.s.)

* Noise level.

PE 1411-12/XX: max. 40 dBA

PE 1413-14/XX: max. 50 dBA

2.1.2 INPUT

Mains voltage (ac.) nominal ; mains frequency

220 V (50 Hz) or

220 V / 240 V (60 Hz) by wiring

Consumption, input current

Type	Im (1)	Fuses (2)
PE 1411 /XX	1,3 A	3,15 A
PE 1412/XX	2,5 A	6,3 A
PE 1413/XX	5 A	10 A
PE 1414/XX	8,6 A	16 A

(1) at mains voltage of 220 V

(2) fuses provided by the user and mounted outside the stabilizer

Efficiency (at full load) : min. 89 %

2.1.3 OUTPUT

ON DELIVERY Type	FILTER CONFIGURATION	
	INPUT	OUTPUT
PE 1411-12-13-14/XX	220 V/50 Hz	220 V

For other configurations, see Table 1.

2.1.4 OUTPUT EFFECTS

2.1.4.1 AS FILTER

- Output voltage nominal value U_{on} : 220 V r.m.s. (+ 1, -1) % or 240 V r.m.s. (+ 2, -2) %
- Source effect (U_m : + 10 % or - 10 %) Valid for a constant mains frequency of 50 Hz, an input distortion of max. 5 % and a linear resistive load between no load and full load. max. -2 %, + 2 %
- Combined load and source effect (U_m and 1.) Valid for a constant mains frequency of 50 Hz, an input distortion of max. 5 % and a linear resistive load between no load and full load:
 - max. -2,9 %, + 6,0 % from U_{on} PE 1411
 - max. -2,5 %, + 4,9 % from U_{on} PE 1412
 - max. -2,1 %, + 4,5 % from U_{on} PE 1413
 - max. -1,8 %, + 4,2 % from U_{on} PE 1414

Warm-up time: 4 hours with a cold core (+ 25°C), the output voltage is approximately 1,5 % higher. * Distortion (output) max. 4 % under all conditions referred to under source and load effect. * Transient suppression : min. 60 dB for asymmetrical pulses *Source frequency effect (f. : 50 Hz +/-2% or 60Hz +/-2%) For each 1 % mains frequency variation, the max. output variation is 1,5 %.

2.1.4.2 AS STABILIZER

- Output voltage nominal value U_{on} : 220 V r.m.s. (+ 1, -1) % or 240 V r.m.s. (+ 2, -2) %
- Source effect (U : + 10 % or - 10 %) Valid for a constant mains frequency of 50 Hz, an input distortion of max. 5 % and a linear resistive load between no load and full load. max. -1%, + 1 % *
 - Combined load and source effect (U_m and 1.) Valid for a constant mains frequency of 50 Hz, an input distortion of max. 5 % and a linear resistive load between no load and full load:
 - max. -1,9 %, + 3,0 % from U_{on} PE 1411
 - max. -1,6 %, + 2,8 % from U_{on} PE 1412
 - max. -1,2 %, + 2,3 % from U_{on} PE 1413
 - max. -1,0 %, + 2,0 % from U_{on} PE 1414

Warm-up time: 4 hours with a cold core (+ 25°C), the output voltage is approximately 1,5 % higher. * Distortion (output) max. 4 % under all conditions referred to under source and load effect. * Transient suppression : unit AI : min. 30 dB for asymmetrical pulses * Source frequency effect (f. : 50 Hz +/-2% or 60 Hz +/-2%) For each 1 % mains frequency variation, the max. output variation is 1,5%.

2.1.5 PROTECTION

Short circuit current : between 150 % and 200 % of the nominal current.

2.2 ENVIRONMENTAL DATA

The environmental data mentioned in this manual are based on the results of the manufacturer's checking procedures..

2.2.1 CLIMATIC CONDITIONS

Designation

Ambient temperature

rated range of use (-10/ + 45)°C

limit range of operation (-20/ + 45)°C

limit range for storage and transport (-40/ + 70)°C

Relative humidity (of ambient air) (20/90) %
non condensing

COOLING

- The ambient temperature is defined as the temperature 20 mm below the unit. Mount the line conditioner unit with the cooling surfaces in a vertical plane so that the air circulation in the unit is maximum.

- The current values given in Section 2.1.3 may be only applied when the unit is in a free-standing position and the rising warmed air is not impeded.

2.2.2 ENVIRONMENTAL TESTS

Performance tests, operating

Description	IEC 68
Cold test	2-1 Ad 2 h. (- 20°C)
Dry heat	2-2 Bd 2 h. (+ 40°C)
Damp heat steady state	2-3 Ca 10 d. (+ 40°C)
Tests for storage and transport	
Description	IEC 68
Cold test	2-8 Ab 72 h. (-40°C)
Dry heat	2-8 Bd 96 h. (+70°C)
Vibration test	2-6 Fc
Bump test	2-29 Eb
Cyclic damp heat test 2	2-30 Db 21 d. (+ 25°C to + 40°C) (90 - 100) % RH

Packaging

according to UN-D-1400

The test methods mentioned are in accordance with those of the relevant ISO-Standards.

2.3 MOUNTING

Connecting block :

INPUT	X1 (/10 /15), mains supply cable (/20)
OUTPUT	X1 (/10 /15), X3 wall plug (/20)

2.4 OPTIONAL ACCESSORIES

Plugs and sockets for versions :

/201 valid in Germany, Austria, Holland, Sweden,....

/202 valid in Belgium, France ,

/203 valid in Great-Britain, Hong-Kong,....

/204 valid in Switzerland.

DIRECTIONS FOR USE

3. INSTALLATION

3.1 INITIAL INSPECTION

Refer to Safety Precautions and Unpacking

SEE WARNING A - PROTECTIVE EARTHING

/10/15 Connect the stabilizer to a protective earth : terminal X4

/20 Provided with a main plug with earth contact.

3.2 MOUNTING INSTRUCTIONS

SEE WARNING A - PROTECTIVE EARTHING

A line conditioner attains a nominal working temperature higher than a conventional transformer, due to the high flux density in the core. A physical spacing and/or orientation of the transformer field must be realized to avoid interactions with circuits like audio, CRT displays, etc..

3.3 DISMANTLING

SEE WARNING B - Before handling or dismantling first disconnect from all voltage sources.

Opening : The apparatus can be accessed by removing the cover.

3.4 OUTPUT CONNECTIONS

NOTE:

The output effects given in Section 2.1.4 can be influenced by external connections or parameters (e.g. cross-sections of the load connections, distance between output terminals and load, characteristics of the load).
/10 /15 version : Connecting block X1 (max. cross-section :1,5 MM²) The cross-section of the wires must be of adequate current-carrying capacity (also dependent on the distance between the line conditioner and the load).

/20 version output :wall plug on the front panel

3.5 MAINS CONNECTION

Before inserting the mains plug into the mains socket, make sure that the instrument is set to the local mains voltage.

NOTE: If the mains plug has to be adapted to the local situation. such adaptation should be done by a qualified person only !

SEE WARNING A - (protective earthing); Page 3

SEE WARNING B - (authorized mains connection & disconnection procedures). Page 3

SEE WARNING C - (fuse types and renewal procedure).Page 3

SEE WARNING D - Page 3

Connect the power supply to the ac. mains voltage by means of a connector mains supply cable .

The current-carrying wires to the mains must be of sufficient cross section depending on the mains voltage and the distance between the mains and the stabilizer..

4. OPERATING INSTRUCTIONS

4.1 GENERAL INFORMATION

This section outlines the procedures and precautions necessary for operation. It identifies and briefly describes the functions of front and rear panel controls and indicators, and explains the practical aspects of operation to enable an operator to evaluate quickly the instrument's main functions.

4.2 SWITCHING "ON"

After the stabilizer has been connected to the mains voltage in accordance with Section 3.1 the instrument is ready for use. With normal installation in accordance with Section 3 and after a warming-up time of 4 hours the characteristics specified in Section 2 are valid.

4.3 CONTROLS, ADJUSTMENTS, INDICATORS AND TERMINALS

Front panel : HI indicates the presence of the output voltage
(/20 version) S1 switch ON/OFF
X3 wall plug

4.4 SERIES, PARALLEL, THREE-PHASE CONNECTIONS

4.4.1 SERIES CONNECTION

Not applicable

4.4.2 PARALLEL CONNECTION

Stabilizers of the same type may be connected in parallel, for technical information please contact ETI.

4.4.3 THREE-PHASE CONNECTIONS

Stabilizers of the same type may be connected in a three-phase configuration; for technical information please contact ETI.

5. ADJUSTMENTS

See WARNING B adjustments by qualified person only.

5.1 GENERAL

WARNING D: when changing the nominal values, the rating type-plate must be suitably amended, Adjustments can be made after opening the apparatus. (see Section 3.3)

5.2 MAINS INPUT

On delivery the stabilizer is wired for
input voltage : **220 V**
mains frequency : **50 Hz**
configuration : **as "FILTER"**

For other configurations, see Table 1.

For 110 V mains connections, **please contact ETI.**

5.3 OUTPUT ADJUSTMENTS

(See Fig. 220)

On delivery the stabilizer is wired for
output voltage : **220 V**
configuration : **as "FILTER"**

For other configurations, see Table 1.

6. SERVICING

See WARNING B; Servicing by qualified person only!

For other technical information is required, please contact ETI.

Safety measures require that the instrument should first be put into its original state and that the spare parts are identical to the original components.

WARNING

-To increase the efficiency of the line conditioner, it is better to use shielded output cables.

- For low frequency noise, connect the shield to the ground at one end (receiving side) only.

- For high frequency noise, connect the shield to the ground at both ends.

- To reduce EMI coupling from other cables and outside EMI ambients, each cable (input , output cable) must be separated from the others : input and output cables should not be near or in parallel to each other. The output cable should be kept from clear of power cables.

-Some EMI problems can be solved by grounding: for 3 phases and parallel configuration, the centralized point ground is the most effective in all conditions.

TABLE 1 : CONNECTIONS POSSIBILITIES

	on delivery													
fm	50 Hz					60 Hz					Type			
FIL./STAB.	FILTER			STABILIZER		FILTER			STABILIZER					
Um	110 V	220 V	240 V	110 V	220 V	110 V	120 V	220 V	240 V	110 V	120 V	220 V	240 V	PE 14.../10 /15 /20
Uon	220 V		240 V	220 V		220 V		240 V	220 V					
FIG.	220			221		222			223					

CONNECTIONS as filter $f_m = 50\text{Hz}$

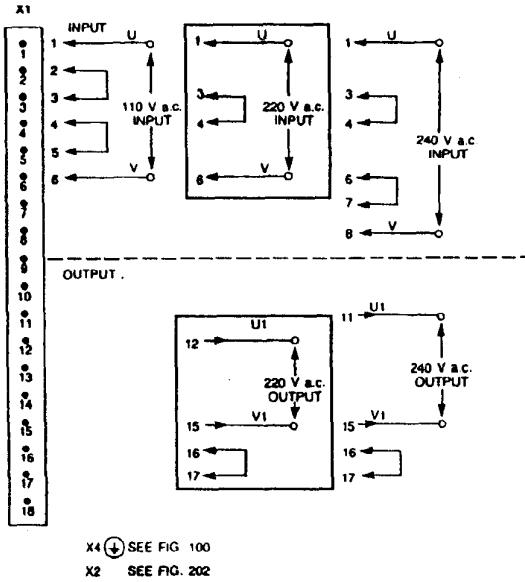

FIG. 220

CONNECTIONS as stabilizer $f_m = 50\text{Hz}$

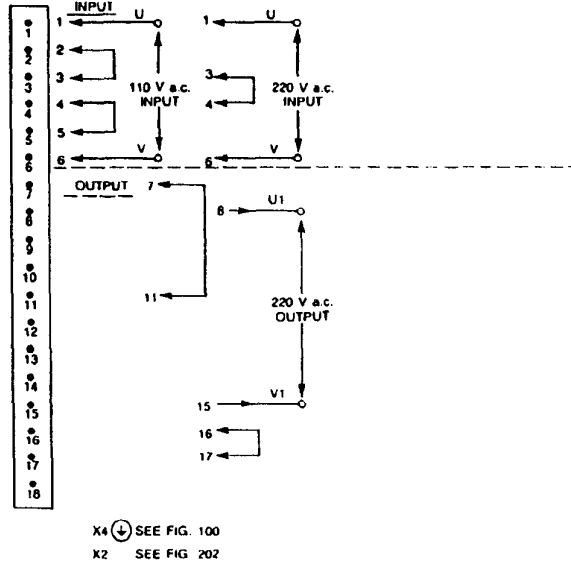

FIG. 221

□ on delivery

CONNECTIONS as filter $f_m = 60\text{Hz}$

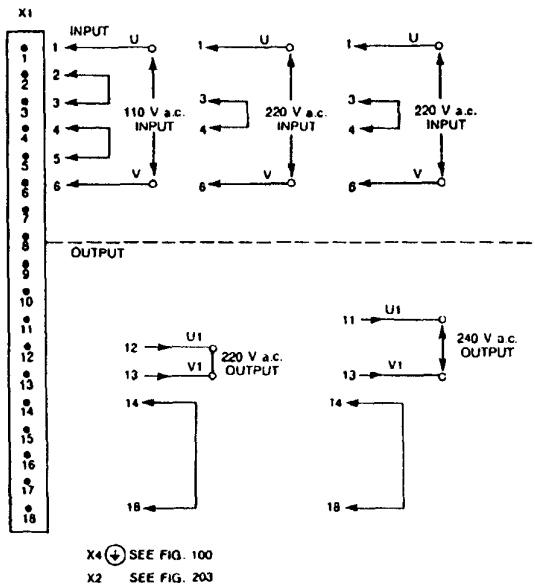

FIG. 222

CONNECTIONS as stabilizer $f_m = 60\text{Hz}$

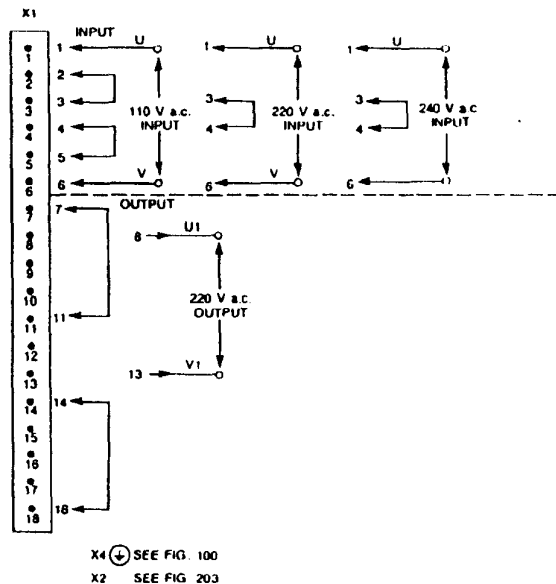
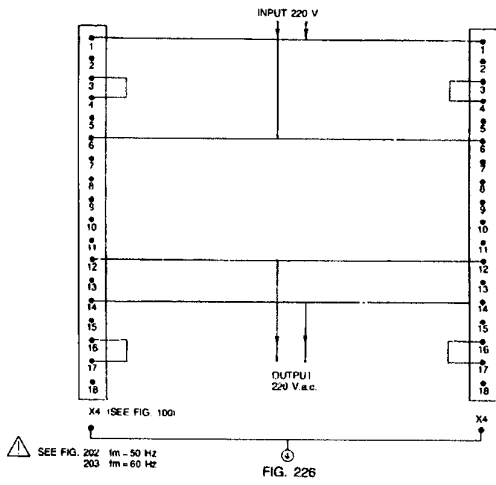
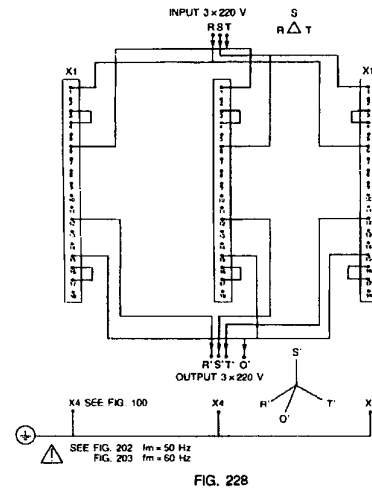

FIG. 223

**Parallel connection
as filter**



**3 phase connection
as filter**



as stabilizer

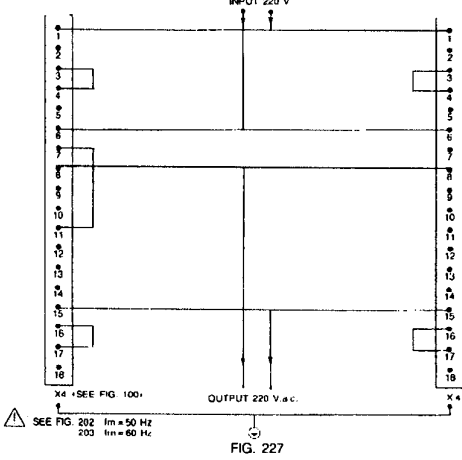

as stabilizer

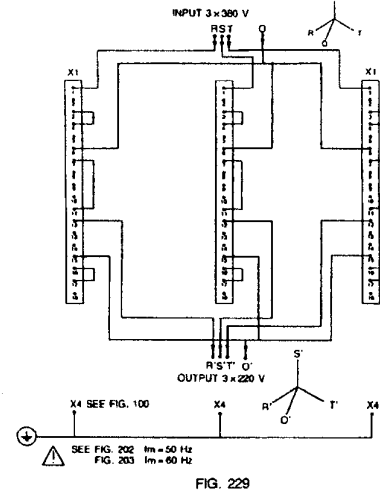

VIEW CAPACITORS

$f_m = 50\text{HZ}$

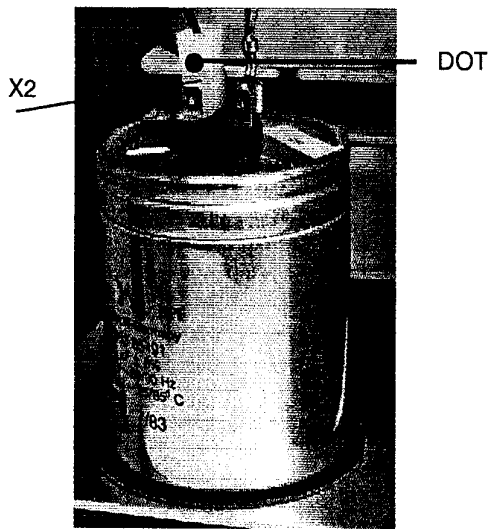

VIEW CAPACITORS

$f_m = 60\text{HZ}$

