

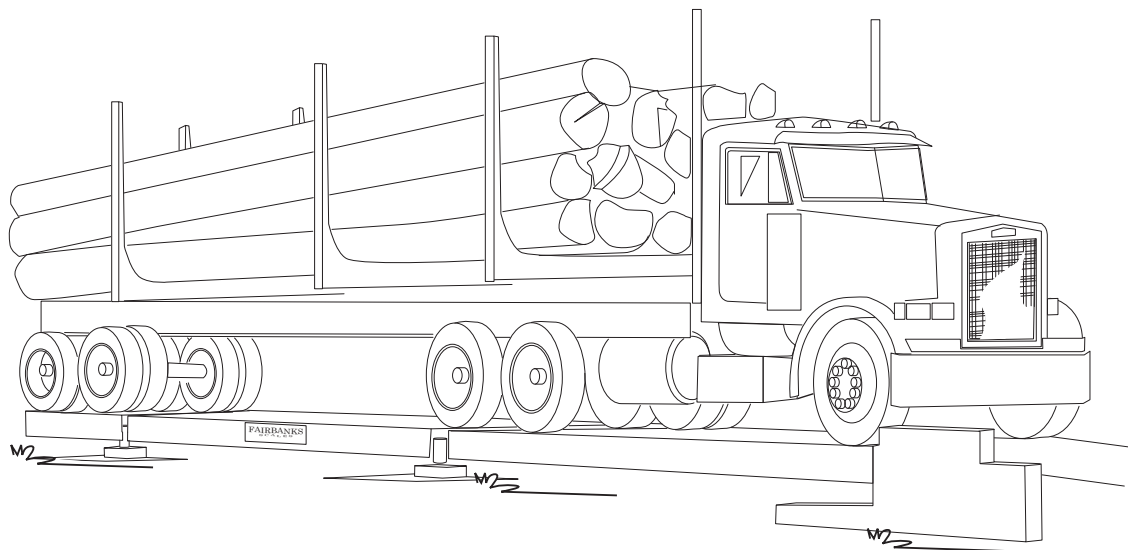

“Rodan RC” Motor Truck Scale

**Model : 6010 Series
6020 Series
6030 Series**



Amendment Record

Rodan RC
50518

Manufactured by Fairbanks Scales Inc.
821 Locust
Kansas City, Missouri 64106

Created

Issue #1

Issue #2

Issue #3

Issue #4

Issue #5

Issue #6 09/99 Product Update, Load Cell changes

Issue #7 06/00 Updated to the new Model Numbers

Issue #8 09/01 Added: EZ-Under Mount design

Issue #9 03/04 Added technical information and corrected drawings.

Issue #10 07/05 Revised replacement parts list.

Revision 11 03/12 Added changes for anti-rotation pins on the load cells ECR 253

Disclaimer

Every effort has been made to provide complete and accurate information in this manual. However, although this manual may include a specifically identified warranty notice for the product, Fairbanks Scales makes no representations or warranties with respect to the contents of this manual, and reserves the right to make changes to this manual without notice when and as improvements are made.

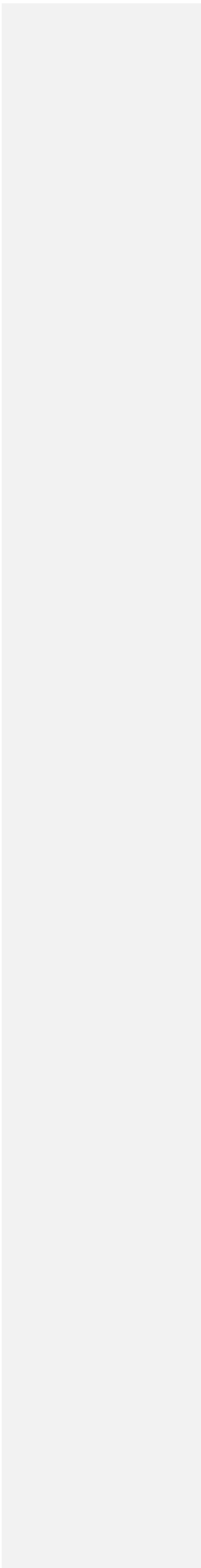

Table of Contents

| | |
|---|----|
| Section 1: Introduction | 5 |
| Section 2: Description | 6 |
| Rodan RC Field Pour Industrial Duty 60K DTAC | 7 |
| Rodan RC Field Pour Heavy Duty 60K DTAC | 8 |
| Rodan RC Field Pour Industrial Duty 80K DTAC | 9 |
| Rodan RC Field Pour Heavy Duty 80K DTAC | 10 |
| Rodan RC Steel Deck Industrial Duty 60K DTAC | 11 |
| Rodan RC Steel Deck Heavy Duty 60K DTAC | 12 |
| Rodan RC Steel Deck Industrial Duty 80K DTAC | 13 |
| Rodan RC Steel Deck Heavy Duty 80K DTAC | 14 |
| Rodan RC Megabar Heavy Duty 60K DTAC | 15 |
| Rodan RC Megabar Heavy Duty 80K DTAC | 16 |
| Section 3: Installation | |
| A. Preparations for Installations, all models | 17 |
| B. Foundation | 19 |
| C. Setting the Modules | 20 |
| Section 4: Field Pour Installation | |
| A. Concrete Specifications | 31 |
| B. Shoring | 31 |
| C. Setting the field pour modules | 33 |
| Section 5: Electrical Installation | |
| A. Balance Box 21912, Installation for Analog Indicators .. | 35 |
| B. Load Cell wiring color codes | 36 |
| C. Wiring | 37 |
| D. Wiring SSCs and PPSs for the Intalogix system | 39 |
| E. SSC | 40 |
| F. Grounding, SSCs | 40 |
| G. Indicator-to-PPS Cable Connection | 40 |

Section 6: Maintenance

Scale Maintenance 41

Section 7: Parts & Part Replacement

A. Parts, Original Style 42
B. Parts, E-Z Mount 42
C. Load Cells and Load Cell Hardware, ALL Models 43
D. "O" Rings , Actual Size 44
E. Replacing an RC Load Cell 45
F. General Load Cell Information 46

Section 8: Accessories

A. Field Installed Rub Rail Installation 47

APPENDIX I: Foundation Check List 48

APPENDIX II: 4 Section Analog Scale 50

APPENDIX III: 5 Section Analog Scale 48

APPENDIX IV: 4 Section Intalogix Scale 48

Section 1: Introduction

This Instruction manual provides installation instructions for the Fairbanks Modular Steel, Field-Pour, and Megabar™ model scales, in both the Original and the EZ-Under-Mount designs.

For correct Rodan scale installation(s), use:

- Methods and Procedures FF-2267 / 101732 (Appendix I)
- The Certified prints/setting plans supplied with the scale
- This Instruction Manual, 50518

The concrete foundation work must be performed according to the Certified prints issued for the specific customer and order number. (The name and order number for the particular customer will be on the prints.)

Section 2: Description

The Modular Steel, Field Pour and Megabar™ truck scales are available in various lengths from 10 to 100 feet and widths from 10' to 12'. The scale is made up of modules of 10', 15', 20' or 23'-4" in length. All modules are assembled and welded at the factory. Megabar™ models have factory poured and cured concrete decks.

The scale should be located so that vehicles can approach and exit the scale as easily as possible. The platform should be visible from the instrument location. Drainage of surface water must be such that water does not collect under the scale. Smooth and level approaches are required at each end of the platform to reduce loading shock and facilitate testing of the scale. Approaches must conform to the requirements of the law in the state in which the scale is being installed. In the absence of such laws the approaches must conform to paragraph UR.2.6 National Institute of Standards and Technology Handbook 44, which states that the first 10 feet must be level and on the same plane as the scale platform.

COC #: 96-089A2

Rodan RC Field Pour Industrial Duty 60K DTAC

| Product Number | Capacity Lbs | Platform Size | Number Sections | DTA Lbs | Modules |
|----------------|--------------|---------------|-----------------|---------|---------|
| 90433 | 30 Ton | 10' x 10' | 2 | 60K | 1 |
| 90013 | 30 Ton | 10' x 11' | 2 | 60K | 1 |
| 90002 | 30 Ton | 15' x 10" | 2 | 60K | 1 |
| 90014 | 30 Ton | 15' x 11" | 2 | 60K | 1 |
| 90003 | 30 Ton | 20' x 10" | 2 | 60K | 1 |
| 90015 | 30 Ton | 20' x 11" | 2 | 60K | 1 |
| 90005 | 60 Ton | 30' x 10" | 3 | 60K | 2 |
| 90017 | 60 Ton | 30' x 11" | 3 | 60K | 2 |
| 90006 | 60 Ton | 40' x 10" | 3 | 60K | 2 |
| 90018 | 60 Ton | 40' x 11" | 3 | 60K | 2 |
| 90007 | 60 Ton | 47' x 10" | 3 | 60K | 2 |
| 90019 | 60 Ton | 47' x 11" | 4 | 60K | 2 |
| 90008 | 100 Ton | 60' x 10" | 4 | 60K | 3 |
| 90020 | 100 Ton | 60' x 11" | 4 | 60K | 3 |
| 90009 | 100 Ton | 70' x 10" | 4 | 60K | 3 |
| 90021 | 100 Ton | 70' x 11" | 4 | 60K | 3 |
| 90010 | 100 Ton | 80' x 10" | 5 | 60K | 4 |
| 90022 | 100 Ton | 80' x 11" | 5 | 60K | 4 |
| 90011 | 100 Ton | 90' x 10" | 5 | 60K | 4 |
| 90023 | 100 Ton | 90' x 11" | 5 | 60K | 4 |
| 90012 | 100 Ton | 100' x 10" | 6 | 60K | 5 |
| 90024 | 100 Ton | 100' x 11" | 6 | 60K | 5 |

Rodan RC Field Pour Heavy Duty 60K DTAC

| Product Number | Capacity Lbs | Platform Size | Number Sections | DTA Lbs | Modules |
|----------------|--------------|---------------|-----------------|---------|---------|
| 90373 | 30 Ton | 10' x 10" | 2 | 60K | 1 |
| 90025 | 30 Ton | 10' x 11" | 2 | 60K | 1 |
| 90374 | 30 Ton | 15' x 10" | 2 | 60K | 1 |
| 90026 | 30 Ton | 15' x 11" | 2 | 60K | 1 |
| 90375 | 30 Ton | 20' x 10" | 2 | 60K | 1 |
| 90027 | 30 Ton | 20' x 11" | 2 | 60K | 1 |
| 90376 | 30 Ton | 23' x 10" | 2 | 60K | 1 |
| 90028 | 30 Ton | 23' x 11" | 2 | 60K | 1 |
| 90377 | 60 Ton | 30' x 10" | 3 | 60K | 2 |
| 90029 | 60 Ton | 30' x 11" | 3 | 60K | 2 |
| 90378 | 60 Ton | 40' x 10" | 3 | 60K | 2 |
| 90030 | 60 Ton | 40' x 11" | 3 | 60K | 2 |
| 90379 | 60 Ton | 47' x 10" | 3 | 60K | 2 |
| 90031 | 60 Ton | 47' x 11" | 3 | 60K | 2 |
| 90380 | 100 Ton | 60' x 10" | 4 | 60K | 3 |
| 90032 | 100 Ton | 60' x 11" | 4 | 60K | 3 |
| 90381 | 100 Ton | 70' x 10" | 4 | 60K | 3 |
| 90033 | 100 Ton | 70' x 11" | 4 | 60K | 3 |
| 90382 | 100 Ton | 80' x 10" | 5 | 60K | 4 |
| 90034 | 100 Ton | 80' x 11" | 5 | 60K | 4 |
| 90383 | 100 Ton | 90' x 10" | 5 | 60K | 4 |
| 90035 | 100 Ton | 90' x 11" | 5 | 60K | 4 |
| 90384 | 100 Ton | 100' x 10" | 6 | 60K | 5 |
| 90036 | 100 Ton | 100' x 11" | 6 | 60K | 5 |

Rodan RC Field Pour Industrial Duty 80K DTAC

| Product Number | Capacity Lbs | Platform Size | Number Sections | DTA Lbs | Modules |
|----------------|--------------|---------------|-----------------|---------|---------|
| 90037 | 40 Ton | 10' x 10" | 2 | 80K | 1 |
| 90049 | 40 Ton | 10' x 11" | 2 | 80K | 1 |
| 90061 | 40 Ton | 10' x 12" | 2 | 80K | 1 |
| 90038 | 40 Ton | 15' x 10" | 2 | 80K | 1 |
| 90050 | 40 Ton | 15' x 11" | 2 | 80K | 1 |
| 90062 | 40 Ton | 15' x 12" | 2 | 80K | 1 |
| 90039 | 40 Ton | 20' x 10" | 2 | 80K | 1 |
| 90051 | 40 Ton | 20' x 11" | 2 | 80K | 1 |
| 90063 | 40 Ton | 20' x 12" | 2 | 80K | 1 |
| 90040 | 40 Ton | 23' x 10" | 2 | 80K | 1 |
| 90052 | 40 Ton | 23' x 11" | 2 | 80K | 1 |
| 90064 | 40 Ton | 23' x 12" | 2 | 80K | 1 |
| 90041 | 70 Ton | 30' x 10" | 3 | 80K | 2 |
| 90053 | 70 Ton | 30' x 11" | 3 | 80K | 2 |
| 90065 | 70 Ton | 30' x 12" | 3 | 80K | 2 |
| 90042 | 70 Ton | 40' x 10" | 3 | 80K | 2 |
| 90054 | 70 Ton | 40' x 11" | 3 | 80K | 2 |
| 90066 | 70 Ton | 40' x 12" | 3 | 80K | 2 |
| 90043 | 70 Ton | 47' x 10" | 3 | 80K | 2 |
| 90055 | 70 Ton | 47' x 11" | 3 | 80K | 2 |
| 90067 | 70 Ton | 47' x 12" | 3 | 80K | 2 |
| 90044 | 100 Ton | 60' x 10" | 4 | 80K | 3 |
| 90056 | 100 Ton | 60' x 11" | 4 | 80K | 3 |
| 90068 | 100 Ton | 60' x 12" | 4 | 80K | 3 |
| 90045 | 100 Ton | 70' x 10" | 4 | 80K | 3 |
| 90057 | 100 Ton | 70' x 11" | 4 | 80K | 3 |
| 90069 | 100 Ton | 70' x 12" | 4 | 80K | 3 |
| 90046 | 100 Ton | 80' x 10" | 5 | 80K | 4 |
| 90058 | 100 Ton | 80' x 11" | 5 | 80K | 4 |
| 90070 | 100 Ton | 80' x 12" | 5 | 80K | 4 |
| 90047 | 100 Ton | 90' x 10" | 5 | 80K | 4 |
| 90059 | 100 Ton | 90' x 11" | 5 | 80K | 4 |
| 90071 | 100 Ton | 90' x 12" | 5 | 80K | 4 |
| 90048 | 100 Ton | 100' x 10" | 6 | 80K | 5 |
| 90060 | 100 Ton | 100' x 11" | 6 | 80K | 5 |
| 90072 | 100 Ton | 100' x 12" | 6 | 80K | 5 |

Rodan RC Field Pour Heavy Duty 80K DTAC

| Product Number | Capacity Lbs | Platform Size | Number Sections | DTA Lbs | Modules |
|----------------|--------------|---------------|-----------------|---------|---------|
| 91841 | 40 Ton | 10' x 10" | 2 | 80K | 1 |
| 91865 | 40 Ton | 10' x 11" | 2 | 80K | 1 |
| 91889 | 40 Ton | 10' x 12" | 2 | 80K | 1 |
| 91842 | 40 Ton | 15' x 10" | 2 | 80K | 1 |
| 91866 | 40 Ton | 15' x 11" | 2 | 80K | 1 |
| 91890 | 40 Ton | 15' x 12" | 2 | 80K | 1 |
| 91843 | 40 Ton | 20' x 10" | 2 | 80K | 1 |
| 91867 | 40 Ton | 20' x 11" | 2 | 80K | 1 |
| 91891 | 40 Ton | 20' x 12" | 2 | 80K | 1 |
| 91844 | 40 Ton | 23' x 10" | 2 | 80K | 1 |
| 91868 | 40 Ton | 23' x 11" | 2 | 80K | 1 |
| 91892 | 40 Ton | 23' x 12" | 2 | 80K | 1 |
| 91845 | 70 Ton | 30' x 10" | 3 | 80K | 2 |
| 91869 | 70 Ton | 30' x 11" | 3 | 80K | 2 |
| 91893 | 70 Ton | 30' x 12" | 3 | 80K | 2 |
| 91846 | 70 Ton | 40' x 10" | 3 | 80K | 2 |
| 91870 | 70 Ton | 40' x 11" | 3 | 80K | 2 |
| 91894 | 70 Ton | 40' x 12" | 3 | 80K | 2 |
| 91847 | 70 Ton | 47' x 10" | 3 | 80K | 2 |
| 91871 | 70 Ton | 47' x 11" | 3 | 80K | 2 |
| 91895 | 70 Ton | 47' x 12" | 3 | 80K | 2 |
| 91848 | 100 Ton | 60' x 10" | 4 | 80K | 3 |
| 91872 | 100 Ton | 60' x 11" | 4 | 80K | 3 |
| 91896 | 100 Ton | 60' x 12" | 4 | 80K | 3 |
| 91849 | 100 Ton | 70' x 10" | 4 | 80K | 3 |
| 91873 | 100 Ton | 70' x 11" | 4 | 80K | 3 |
| 91897 | 100 Ton | 70' x 12" | 4 | 80K | 3 |
| 91850 | 100 Ton | 80' x 10" | 5 | 80K | 4 |
| 91874 | 100 Ton | 80' x 11" | 5 | 80K | 4 |
| 91898 | 100 Ton | 80' x 12" | 5 | 80K | 4 |
| 91851 | 100 Ton | 90' x 10" | 5 | 80K | 4 |
| 91875 | 100 Ton | 90' x 11" | 5 | 80K | 4 |
| 91899 | 100 Ton | 90' x 12" | 5 | 80K | 4 |
| 91852 | 100 Ton | 100' x 10" | 6 | 80K | 5 |
| 91876 | 100 Ton | 100' x 11" | 6 | 80K | 5 |
| 91900 | 100 Ton | 100' x 12" | 6 | 80K | 5 |

Rodan RC Steel Deck Industrial Duty 60K DTAC

| Product Number | Capacity Lbs | Platform Size | Number Sections | DTA Lbs | Modules |
|----------------|--------------|---------------|-----------------|---------|---------|
| 90157 | 30 Ton | 10' x 10" | 2 | 60K | 1 |
| 90217 | 30 Ton | 10' x 11" | 2 | 60K | 1 |
| 90158 | 30 Ton | 15' x 10" | 2 | 60K | 1 |
| 90218 | 30 Ton | 15' x 11" | 2 | 60K | 1 |
| 90159 | 30 Ton | 20' x 10" | 2 | 60K | 1 |
| 90219 | 30 Ton | 20' x 11" | 2 | 60K | 1 |
| 90160 | 30 Ton | 23' x 10" | 2 | 60K | 1 |
| 90220 | 30 Ton | 23' x 11" | 2 | 60K | 1 |
| 90161 | 60 Ton | 30' x 10" | 3 | 60K | 2 |
| 60221 | 60 Ton | 30' x 11" | 3 | 60K | 2 |
| 90162 | 60 Ton | 40' x 10" | 3 | 60K | 2 |
| 90222 | 60 Ton | 40' x 11" | 3 | 60K | 2 |
| 90163 | 60 Ton | 47' x 10" | 3 | 60K | 2 |
| 90223 | 60 Ton | 47' x 11" | 3 | 60K | 2 |
| 90164 | 100 Ton | 60' x 10" | 4 | 60K | 3 |
| 90224 | 100 Ton | 60' x 11" | 4 | 60K | 3 |
| 90165 | 100 Ton | 70' x 10" | 4 | 60K | 3 |
| 90225 | 100 Ton | 70' x 11" | 4 | 60K | 3 |
| 90166 | 100 Ton | 80' x 10" | 5 | 60K | 4 |
| 90226 | 100 Ton | 80' x 11" | 5 | 60K | 4 |
| 90167 | 100 Ton | 90' x 10" | 5 | 60K | 4 |
| 90227 | 100 Ton | 90' x 11" | 5 | 60K | 4 |
| 90168 | 100 Ton | 100' x 10" | 6 | 60K | 5 |
| 90228 | 100 Ton | 100' x 11" | 6 | 60K | 5 |

Rodan RC Steel Deck Heavy Duty 60K DTAC

| Product Number | Capacity Lbs | Platform Size | Number Sections | DTA Lbs | Modules |
|----------------|--------------|---------------|-----------------|---------|---------|
| 90097 | 30 Ton | 10' x 10" | 2 | 60K | 1 |
| 90109 | 30 Ton | 10' x 11" | 2 | 60K | 1 |
| 90098 | 30 Ton | 15' x 10" | 2 | 60K | 1 |
| 90110 | 30 Ton | 15' x 11" | 2 | 60K | 1 |
| 90099 | 30 Ton | 20' x 10" | 2 | 60K | 1 |
| 90111 | 30 Ton | 20' x 11" | 2 | 60K | 1 |
| 90100 | 30 Ton | 23' x 10" | 2 | 60K | 1 |
| 90112 | 30 Ton | 23' x 11" | 2 | 60K | 1 |
| 90101 | 60 Ton | 30' x 10" | 3 | 60K | 2 |
| 90113 | 60 Ton | 30' x 11" | 3 | 60K | 2 |
| 90102 | 60 Ton | 40' x 10" | 3 | 60K | 2 |
| 90114 | 60 Ton | 40' x 11" | 3 | 60K | 2 |
| 90103 | 60 Ton | 47' x 10" | 3 | 60K | 2 |
| 90115 | 60 Ton | 47' x 11" | 3 | 60K | 2 |
| 90104 | 100 Ton | 60' x 10" | 4 | 60K | 3 |
| 90116 | 100 Ton | 60' x 11" | 4 | 60K | 3 |
| 90105 | 100 Ton | 70' x 10" | 4 | 60K | 3 |
| 90117 | 100 Ton | 70' x 11" | 4 | 60K | 3 |
| 90106 | 100 Ton | 80' x 10" | 5 | 60K | 4 |
| 90118 | 100 Ton | 80' x 11" | 5 | 60K | 4 |
| 60107 | 100 Ton | 90' x 10" | 5 | 60K | 4 |
| 90119 | 100 Ton | 90' x 11" | 5 | 60K | 4 |
| 90108 | 100 Ton | 100' x 10" | 6 | 60K | 5 |
| 90120 | 100 Ton | 100' x 11" | 6 | 60K | 5 |

Rodan RC Steel Deck Industrial Duty 80K DTAC

| Product Number | Capacity Lbs | Platform Size | Number Sections | DTA Lbs | Modules |
|----------------|--------------|---------------|-----------------|---------|---------|
| 90121 | 40 Ton | 10' x 10" | 2 | 80K | 1 |
| 90133 | 40 Ton | 10' x 11" | 2 | 80K | 1 |
| 90145 | 40 Ton | 10' x 12" | 2 | 80K | 1 |
| 90122 | 40 Ton | 15' x 10" | 2 | 80K | 1 |
| 90134 | 40 Ton | 15' x 11" | 2 | 80K | 1 |
| 90146 | 40 Ton | 15' x 12" | 2 | 80K | 1 |
| 90123 | 40 Ton | 20' x 10" | 2 | 80K | 1 |
| 90111 | 40 Ton | 20' x 11" | 2 | 80K | 1 |
| 90147 | 40 Ton | 20' x 12" | 2 | 80K | 1 |
| 90124 | 40 Ton | 23' x 10" | 2 | 80K | 1 |
| 90136 | 40 Ton | 23' x 11" | 2 | 80K | 1 |
| 90148 | 40 Ton | 23' x 12" | 2 | 80K | 1 |
| 90125 | 70 Ton | 30' x 10" | 3 | 80K | 2 |
| 90137 | 70 Ton | 30' x 11" | 3 | 80K | 2 |
| 90149 | 70 Ton | 30' x 12" | 3 | 80K | 2 |
| 90126 | 70 Ton | 40' x 10" | 3 | 80K | 2 |
| 90138 | 70 Ton | 40' x 11" | 3 | 80K | 2 |
| 90150 | 70 Ton | 40' x 12" | 3 | 80K | 2 |
| 90127 | 70 Ton | 47' x 10" | 3 | 80K | 2 |
| 90139 | 70 Ton | 47' x 11" | 3 | 80K | 2 |
| 90151 | 70 Ton | 47' x 12" | 3 | 80K | 2 |
| 90128 | 100 Ton | 60' x 10" | 4 | 80K | 3 |
| 90140 | 100 Ton | 60' x 11" | 4 | 80K | 3 |
| 90152 | 100 Ton | 60' x 12" | 4 | 80K | 3 |
| 90129 | 100 Ton | 70' x 10" | 4 | 80K | 3 |
| 90141 | 100 Ton | 70' x 11" | 4 | 80K | 3 |
| 90153 | 100 Ton | 70' x 12" | 4 | 80K | 3 |
| 90130 | 100 Ton | 80' x 10" | 5 | 80K | 4 |
| 90142 | 100 Ton | 80' x 11" | 5 | 80K | 4 |
| 90154 | 100 Ton | 80' x 12" | 5 | 80K | 4 |
| 90131 | 100 Ton | 90' x 10" | 5 | 80K | 4 |
| 90143 | 100 Ton | 90' x 11" | 5 | 80K | 4 |
| 90155 | 100 Ton | 90' x 12" | 5 | 80K | 4 |
| 90132 | 100 Ton | 100' x 10" | 6 | 80K | 5 |
| 90144 | 100 Ton | 100' x 11" | 6 | 80K | 5 |
| 90156 | 100 Ton | 100' x 12" | 6 | 80K | 5 |

Rodan RC Steel Deck Heavy Duty 80K DTAC

| Product Number | Capacity Lbs | Platform Size | Number Sections | DTA Lbs | Modules |
|----------------|--------------|---------------|-----------------|---------|---------|
| 91769 | 40 Ton | 10' x 10" | 2 | 80K | 1 |
| 91793 | 40 Ton | 10' x 11" | 2 | 80K | 1 |
| 91817 | 40 Ton | 10' x 12" | 2 | 80K | 1 |
| 91770 | 40 Ton | 15' x 10" | 2 | 80K | 1 |
| 91794 | 40 Ton | 15' x 11" | 2 | 80K | 1 |
| 91818 | 40 Ton | 15' x 12" | 2 | 80K | 1 |
| 91771 | 40 Ton | 20' x 10" | 2 | 80K | 1 |
| 91795 | 40 Ton | 20' x 11" | 2 | 80K | 1 |
| 91819 | 40 Ton | 20' x 12" | 2 | 80K | 1 |
| 91772 | 40 Ton | 23' x 10" | 2 | 80K | 1 |
| 91796 | 40 Ton | 23' x 11" | 2 | 80K | 1 |
| 91820 | 40 Ton | 23' x 12" | 2 | 80K | 1 |
| 91773 | 70 Ton | 30'4" x 10" | 3 | 80K | 2 |
| 91797 | 70 Ton | 30'4" x 11" | 3 | 80K | 2 |
| 91821 | 70 Ton | 30'4" x 12" | 3 | 80K | 2 |
| 91774 | 70 Ton | 40'4" x 10" | 3 | 80K | 2 |
| 91798 | 70 Ton | 40'4" x 11" | 3 | 80K | 2 |
| 91822 | 70 Ton | 40'4" x 12" | 3 | 80K | 2 |
| 91775 | 70 Ton | 47' x 10" | 3 | 80K | 2 |
| 91799 | 70 Ton | 47' x 11" | 3 | 80K | 2 |
| 91823 | 70 Ton | 47' x 12" | 3 | 80K | 2 |
| 91776 | 100 Ton | 60' x 10" | 4 | 80K | 3 |
| 91800 | 100 Ton | 60' x 11" | 4 | 80K | 3 |
| 91824 | 100 Ton | 60' x 12" | 4 | 80K | 3 |
| 91777 | 100 Ton | 70' x 10" | 4 | 80K | 3 |
| 91801 | 100 Ton | 70' x 11" | 4 | 80K | 3 |
| 91825 | 100 Ton | 70' x 12" | 4 | 80K | 3 |
| 91778 | 100 Ton | 80' x 10" | 5 | 80K | 4 |
| 91802 | 100 Ton | 80' x 11" | 5 | 80K | 4 |
| 91826 | 100 Ton | 80' x 12" | 5 | 80K | 4 |
| 91779 | 100 Ton | 90' x 10" | 5 | 80K | 4 |
| 91803 | 100 Ton | 90' x 11" | 5 | 80K | 4 |
| 91827 | 100 Ton | 90' x 12" | 5 | 80K | 4 |
| 91780 | 100 Ton | 100' x 10" | 6 | 80K | 5 |
| 91804 | 100 Ton | 100' x 11" | 6 | 80K | 5 |
| 91828 | 100 Ton | 100' x 12" | 6 | 80K | 5 |

Rodan RC Megabar Heavy Duty 60K DTAC

| Product Number | Capacity Lbs | Platform Size | Number Sections | DTA Lbs | Modules |
|----------------|--------------|---------------|-----------------|---------|---------|
| 90181 | 30 Ton | 10' x 10" | 2 | 60K | 1 |
| 90193 | 30 Ton | 10' x 11" | 2 | 60K | 1 |
| 90182 | 30 Ton | 15' x 10" | 2 | 60K | 1 |
| 90194 | 30 Ton | 15' x 11" | 2 | 60K | 1 |
| 90183 | 30 Ton | 20' x 10" | 2 | 60K | 1 |
| 90195 | 30 Ton | 20' x 11" | 2 | 60K | 1 |
| 90184 | 30 Ton | 23' x 10" | 2 | 60K | 1 |
| 90196 | 30 Ton | 23' x 11" | 2 | 60K | 1 |
| 90185 | 60 Ton | 30' x 10" | 3 | 60K | 2 |
| 90197 | 60 Ton | 30' x 11" | 3 | 60K | 2 |
| 90186 | 60 Ton | 40' x 10" | 3 | 60K | 2 |
| 90198 | 60 Ton | 40' x 11" | 3 | 60K | 2 |
| 90187 | 60 Ton | 47' x 10" | 3 | 60K | 2 |
| 90199 | 60 Ton | 47' x 11" | 3 | 60K | 2 |
| 90188 | 100 Ton | 60' x 10" | 4 | 60K | 3 |
| 90200 | 100 Ton | 60' x 11" | 4 | 60K | 3 |
| 90189 | 100 Ton | 70' x 10" | 4 | 60K | 3 |
| 90201 | 100 Ton | 70' x 11" | 4 | 60K | 3 |
| 90190 | 100 Ton | 80' x 10" | 5 | 60K | 4 |
| 90202 | 100 Ton | 80' x 11" | 5 | 60K | 4 |
| 90191 | 100 Ton | 90' x 10" | 5 | 60K | 4 |
| 90203 | 100 Ton | 90' x 11" | 5 | 60K | 4 |
| 90192 | 100 Ton | 100' x 10" | 6 | 60K | 5 |
| 90204 | 100 Ton | 100' x 11" | 6 | 60K | 5 |

Rodan RC Megabar Heavy Duty 80K DTAC

| Product Number | Capacity Lbs | Platform Size | Number Sections | DTA Lbs | Modules |
|----------------|--------------|---------------|-----------------|---------|---------|
| 91685 | 40 Ton | 10' x 10" | 2 | 80K | 1 |
| 91697 | 40 Ton | 10' x 11" | 2 | 80K | 1 |
| 91709 | 40 Ton | 10' x 12" | 2 | 80K | 1 |
| 91686 | 40 Ton | 15' x 10" | 2 | 80K | 1 |
| 91698 | 40 Ton | 15' x 11" | 2 | 80K | 1 |
| 91710 | 40 Ton | 15' x 12" | 2 | 80K | 1 |
| 91687 | 40 Ton | 20' x 10" | 2 | 80K | 1 |
| 91699 | 40 Ton | 20' x 11" | 2 | 80K | 1 |
| 91711 | 40 Ton | 20' x 12" | 2 | 80K | 1 |
| 91688 | 40 Ton | 23' x 10" | 2 | 80K | 1 |
| 91700 | 40 Ton | 23' x 11" | 2 | 80K | 1 |
| 91712 | 40 Ton | 23' x 12" | 2 | 80K | 1 |
| 91689 | 70 Ton | 30'4" x 10" | 3 | 80K | 2 |
| 91701 | 70 Ton | 30'4" x 11" | 3 | 80K | 2 |
| 91713 | 70 Ton | 30'4" x 12" | 3 | 80K | 2 |
| 91690 | 70 Ton | 40'4" x 10" | 3 | 80K | 2 |
| 91702 | 70 Ton | 40'4" x 11" | 3 | 80K | 2 |
| 91714 | 70 Ton | 40'4" x 12" | 3 | 80K | 2 |
| 91691 | 70 Ton | 47' x 10" | 3 | 80K | 2 |
| 91703 | 70 Ton | 47' x 11" | 3 | 80K | 2 |
| 91715 | 70 Ton | 47' x 12" | 3 | 80K | 2 |
| 91692 | 100 Ton | 60' x 10" | 4 | 80K | 3 |
| 91704 | 100 Ton | 60' x 11" | 4 | 80K | 3 |
| 91716 | 100 Ton | 60' x 12" | 4 | 80K | 3 |
| 91693 | 100 Ton | 70' x 10" | 4 | 80K | 3 |
| 91705 | 100 Ton | 70' x 11" | 4 | 80K | 3 |
| 91717 | 100 Ton | 70' x 12" | 4 | 80K | 3 |
| 91694 | 100 Ton | 80' x 10" | 5 | 80K | 4 |
| 91706 | 100 Ton | 80' x 11" | 5 | 80K | 4 |
| 91718 | 100 Ton | 80' x 12" | 5 | 80K | 4 |
| 91695 | 100 Ton | 90' x 10" | 5 | 80K | 4 |
| 91707 | 100 Ton | 90' x 11" | 5 | 80K | 4 |
| 91719 | 100 Ton | 90' x 12" | 5 | 80K | 4 |
| 91696 | 100 Ton | 100' x 10" | 6 | 80K | 5 |
| 91708 | 100 Ton | 100' x 11" | 6 | 80K | 5 |
| 91720 | 100 Ton | 100' x 12" | 6 | 80K | 5 |

Section 3: Installation

Installation consists of the following:

- Foundation check, layout, and base plate setting
- Tools, materials, documentation, and a crane
- Setting the modules
- Setting the modules on load cells



Note: Original style Rodans and the 'EZ-Under-Mount' style differ in installation procedures. Additional installation instructions are provided for the Field-Pour deck in Section 4 of this manual.

A. Preparations for Installations, all Models:

Tools, Equipment, and Materials Required:

1. Certified Prints
2. A mobile crane of sufficient capacity to safely lift and place the weighbridge modules.

Approximate maximum weights:

- Steel modules - 4 tons
- MegaBar™ modules - 6.5 tons
- Field pour Modules - 2.5 tons
w/concrete - 25K - 30K lbs +/-5%

3. Four (4) equal length (20 ft) lifting chains or cables with hooks to safely attach to the modules near each corner



NOTE: These MUST be requested in advance from the Crane Service Company!

4. Machinists levels (starrett # 134 & 132-6)
5. Hand tools
6. Hammer Drill with 5/8" bit, 16" long

7. Hydraulic jacks-Use hydraulic jacks that have sufficient capacity + a safety factor for the model scale you are installing.

- Steel modules 10 ton hydraulic jacks (2)
- MegaBar™ modules 15 ton hydraulic jacks (2)
- Field pour Modules 30 ton hydraulic jacks (2)
- 93296 30 ton jacks
- 93297 Hand pump
- 93298 Hose, 6'

8. 100' steel tape measure

9. Stringline or chalkline (both)

10. Prybars

11. Quality grease and anti-seize

**12. Load cell locating tools, one for each load cell,
available from CPD**

Part No. 71717 for 5 ½"

Part No. 76623 for 7"

13. 4" x 4" x 12' timbers (supplied) for field pour models

B. Foundation:

Before installing any part of the scale, the foundation must be checked for accuracy using Foundation Inspection, Field Check List, FF-2267/101732 (see Appendix I).

1. Layout and position the base plates in the proper locations using the Methods & Procedures and Certified prints. Each base plate must be level and in full contact with the top of the pier. Adjustments can be made by chipping the concrete or grouting (thinly, enough to fill in small imperfections) under the base plates. A maximum of +/- 1/8" adjustment is allowed.
2. Re-check the locations of each base plate against the Certified Prints.
 - **Original Rodan types:** Insert two 1/2" roll pins into each base plate for anti-rotation. Position the plates with pins toward the OUTSIDE. This will leave the load cell cable and the anti-rotation pin exiting the cell to the INSIDE. It is NOT necessary to install base plate anchors at this time.
 - **E-Z Under Mounts:** Insert two 1/2" roll pins into each lower cup for anti-rotation.



WARNING: The base plate's center anchor bolt (5/8" x 6") MUST be installed in each plate at this time.

3. For 5 1/2" and 7" cell cups, grease and install the inner "O" ring in each cup if they are not already installed. On all cups, grease the large outer "O" rings, then install one in the groove on the outside of each cup. Put a 3/16" shim on the lower cups, grease the outsides, then insert them into the base plates. Lower cups for 5 1/2" or 7" load cells have a pin which must be aligned between the two roll pins in the base plate.
4. Place the upper cup with greased "O" ring on the edge of the the upper foundation next to each base plate.
5. Place the proper sized load cell locating tool next to each base plate.

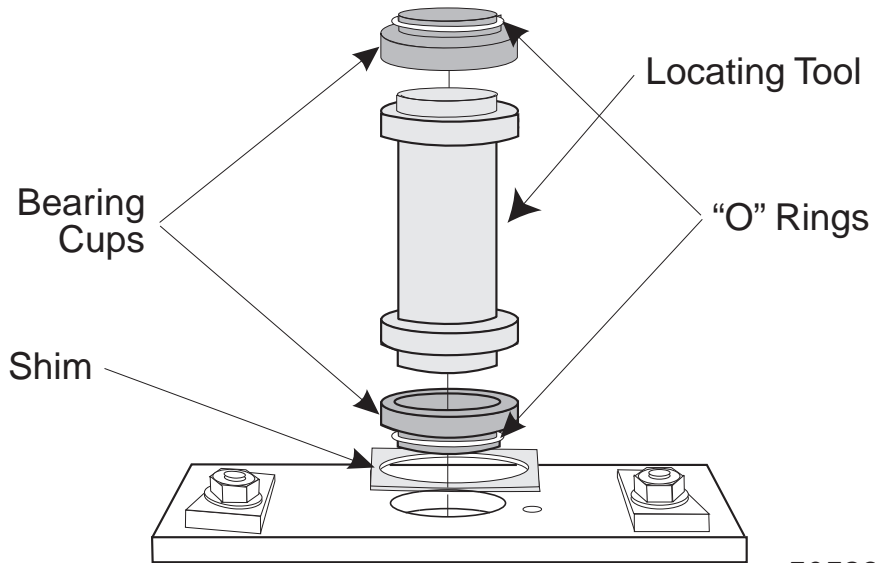

Note: If this is a field pour installation, see Section 4 of this manual.

C. Setting The Modules:

1. Preparing The Modules For Lifting

- **Original Rodan types:**

The original style modules must have lifting brackets installed at each corner before they can be lifted. Use only the high-strength bolts provided or parts from the factory. Tighten the bolts as tight as possible.

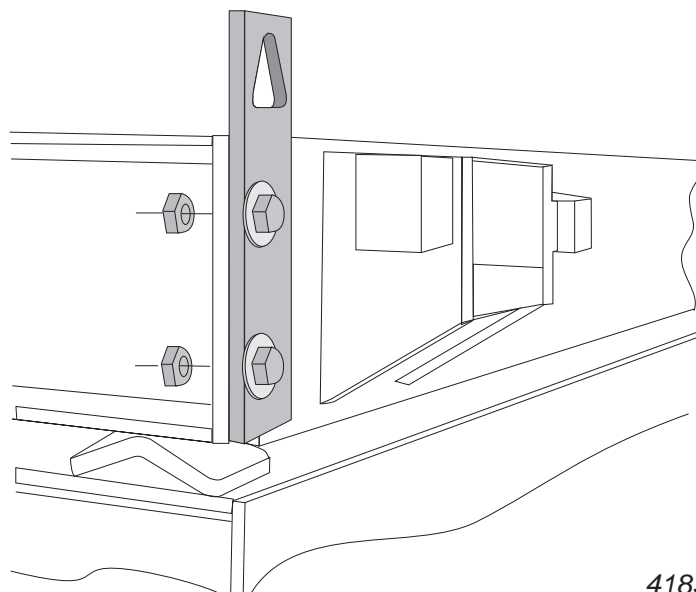

4183

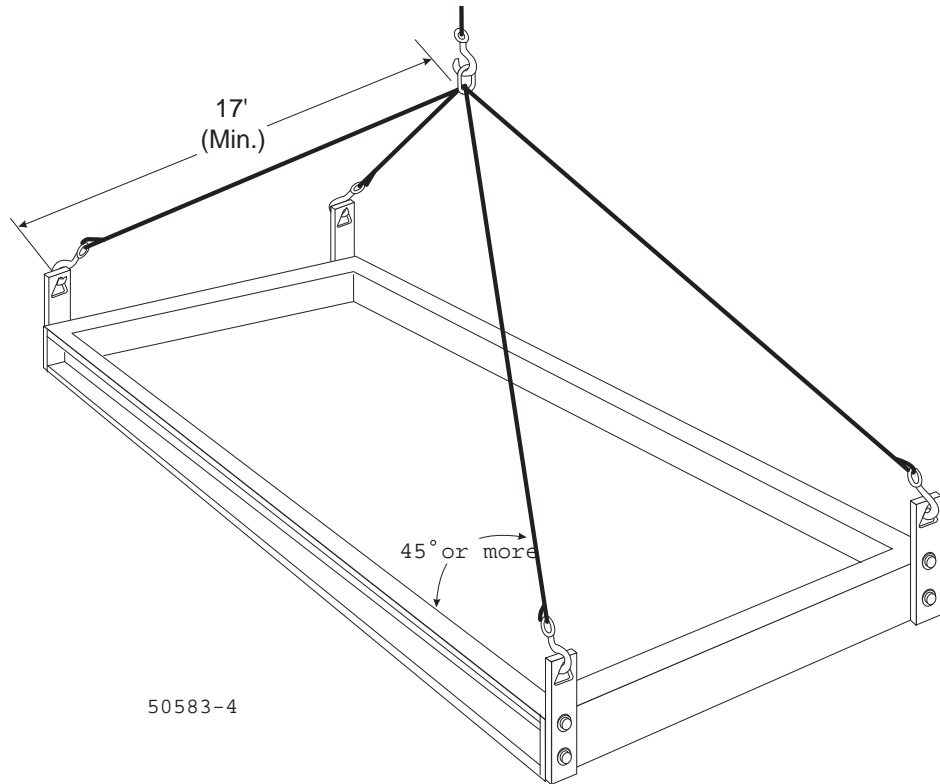

- **E-Z Under Mounts:** The newer modules are complete with channel pieces welded to the sides for attaching lifting hooks. NO bolts are needed.

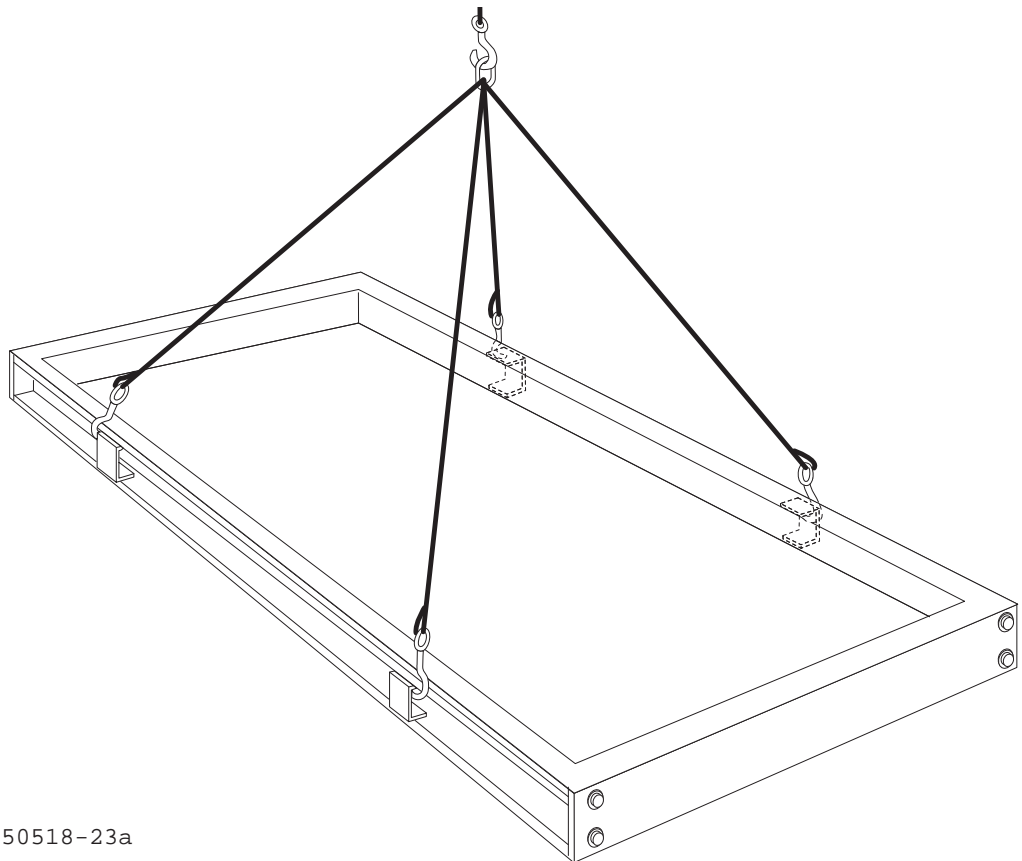

2. Setting The Center Module:

The center module is always set first. The center module will have four load cells to install; all other modules will have two load cells. The modules must be placed in the proper order and aligned in the foundation so that all modules fit correctly.

- **Original Rodan types:** These scales do NOT have a left-right orientation and have 'unmarked' ends. The center module may be installed facing either direction as long as it is in the center. The other modules will set upon the center module from either end.
- **E-Z Under Mounts:** These scales HAVE a definite orientation because the cable conduit is welded to 1 side only. These modules have 'unmarked' ends as well. The conduit side of the center module should face the 'home-run' conduit; the conduit side of the other modules must face the same way.

Both Types:

- a. Place blocks that will set the modules at a height slightly less than the finished height as safety blocks, or for setting modules on.
- b. Lift the center module to a location above the four center load cell base plates.

OPTION 1: You may set the module directly on the locating tools and the blocks will act as safety stands.

- Install a Load Cell Bearing Cup with "O" rings into the upper receiver of each corner, grease will help hold the cup in place.
- Insert the upper end of the locating tool into the upper cup on the module.
- Lower the module while holding the locating tool upright and guiding the bottom of the tool into the lower cup.

- When the center module is set on all four locating tools, keep tension on the cables until the module is centered and straight.
- Use hydraulic jacks to lift the unit slightly and shift the base plates to get the locating tools PLUMB and the top and bottom flanges FLUSH with the sides of the cup.

OPTION 2: Set the modules on the blocks first, then onto locating tools.

- When the module is set on the blocks, keep tension on the cables until the module is properly aligned.
 - Use hydraulic jacks to lift the unit slightly, then install the locating tools. Shift the base plates to get the tools PLUMB and the top and bottom flanges FLUSH with the sides of the cup.
- c.** Measure from each side of each end of the module to the end walls, to be certain the module is plumb and square before removing tension.
- d.** Once the tension on the lift cables is released, remove the lift brackets and/or hooks.

3. Setting End Modules, Both Types:

a. Interlocking Pin

- **Original Rodan types:** Drive an interlocking pin into each load cell bracket of the center module.

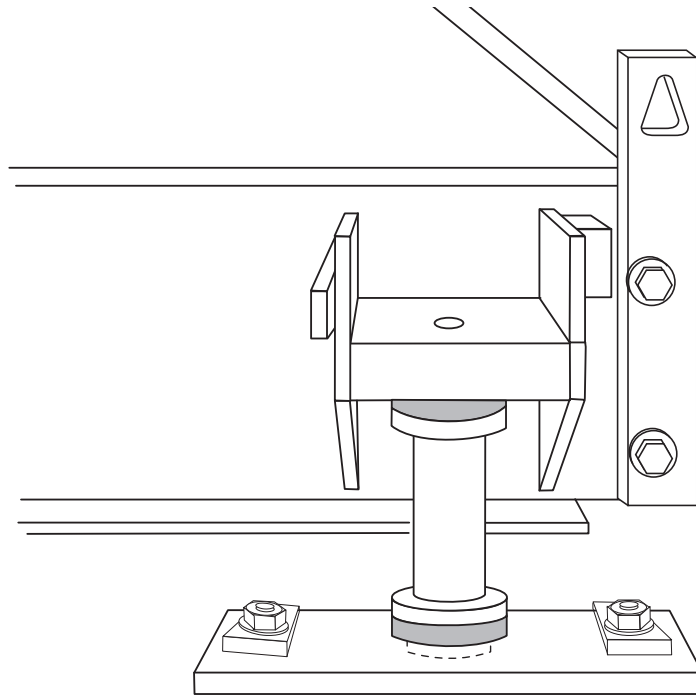

50518-4

- **E-Z Under Mounts:** No action required.

b. Module Placement

- **Original Rodan types:** Guide the modules into place with the supporting blocks on the end of the module coming to rest on the center module load cell bracket interlocking pins. Lower the other end of the module onto the load cell locating tools or blocks.

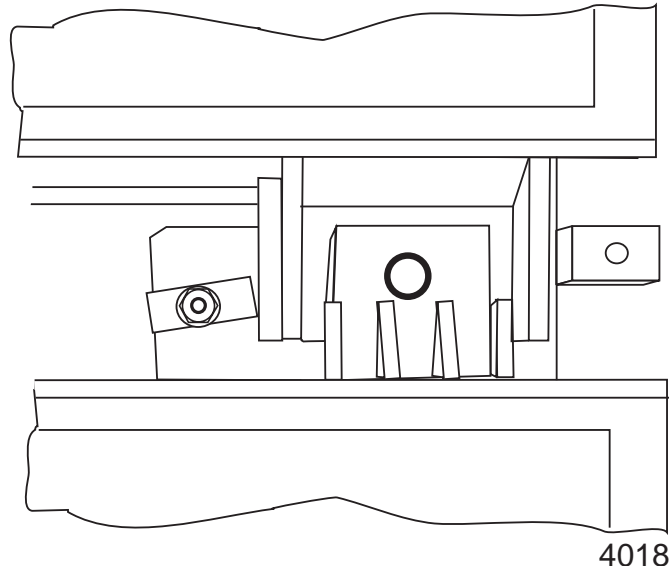

- **E-Z Under Mounts:** Guide the modules into place with the supporting blocks on the end of the module coming to rest on the supporting blocks of the center module. Lower the other end of the module onto the load cell locating tools or blocks.

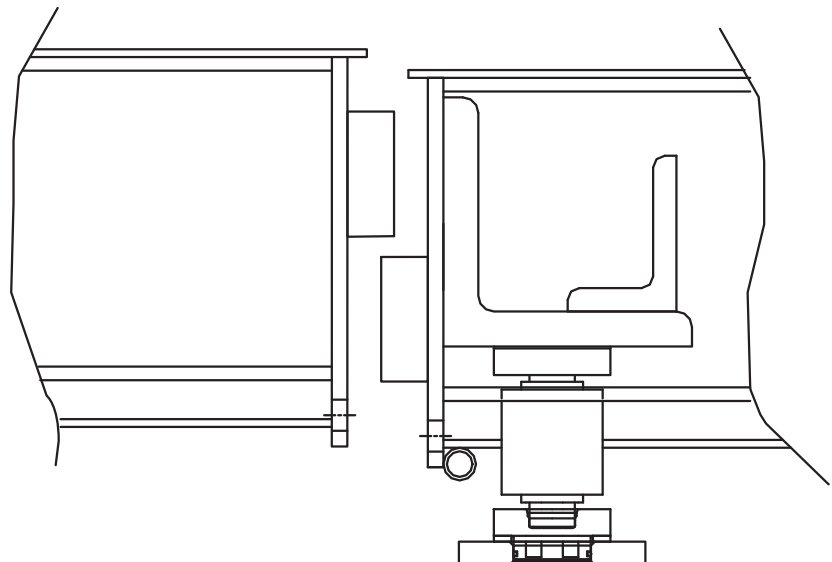

4. Before releasing tension on the cables, check the alignment of the end modules to the center module and to the end wall.

- **Original Rodan types:** Ensure end modules are aligned with the center module and the foundation.
- **E-Z Under Mounts:** Use the provided shims to set height and fill any gaps on the supporting blocks to get the modules aligned.

5. Connecting the Modules:

- **Original Rodan types:** Bolt the modules' channels together using the $\frac{1}{2}$ " x 4" x 6" spacers and 1" x 3" bolts. Insert the $\frac{1}{2}$ " x 4" x 6" spacer plates between the channels. The bolts go through the back-to-back channels and the spacer. Snug the bolts, but do not tighten yet.

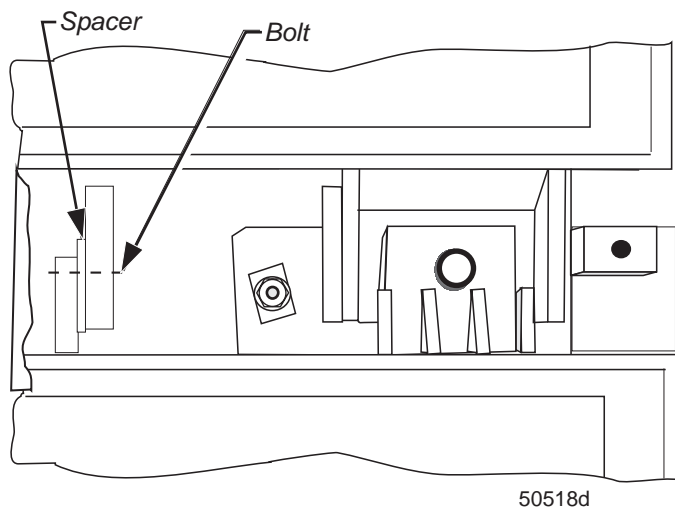

- **E-Z Under Mounts:** Bolt the modules together using the 1 1/8" x 4 1/2" bolt, lock washer, flat washers and nut provided. Remember to shim the supporting blocks if necessary to align modules.

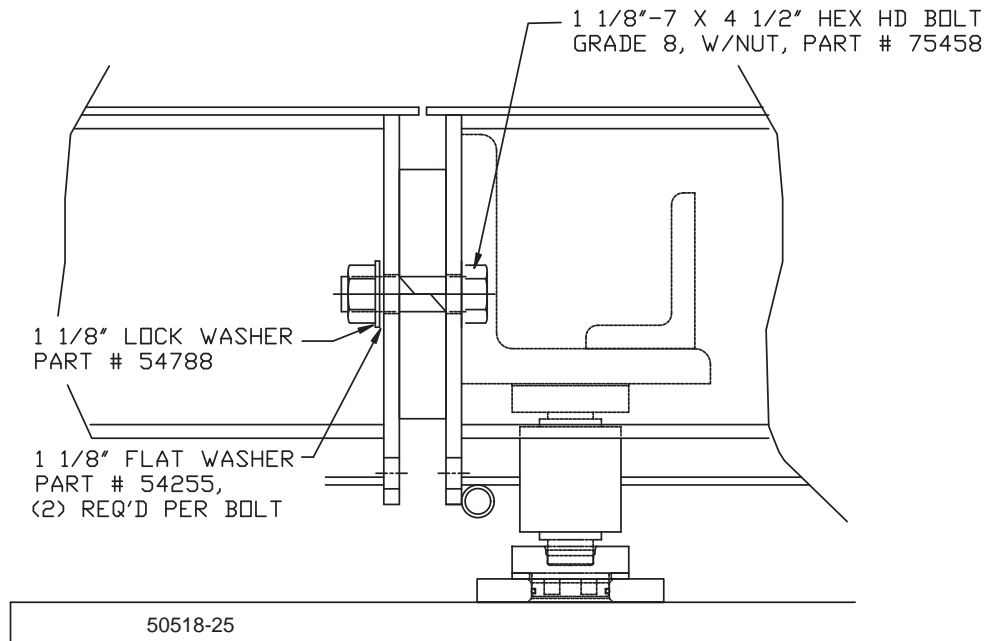

Warning: Module-to-module bolts MUST be installed correctly and torqued properly after all lifting, etc. is completed. Do NOT substitute or omit bolts.

6. Checking Adjustment

a. Adjust End Checking

- **Original Rodan Type:** Use the end checking shims provided to adjust end checking so that they touch and prevent movement.

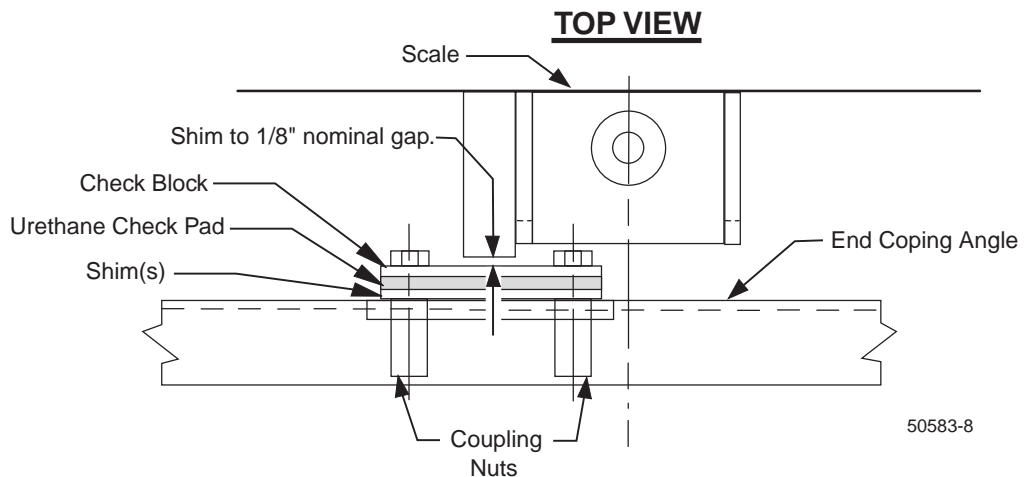

- **E-Z Under Mounts:** Adjust the End Checking Bolt so that they touch and prevent movement.

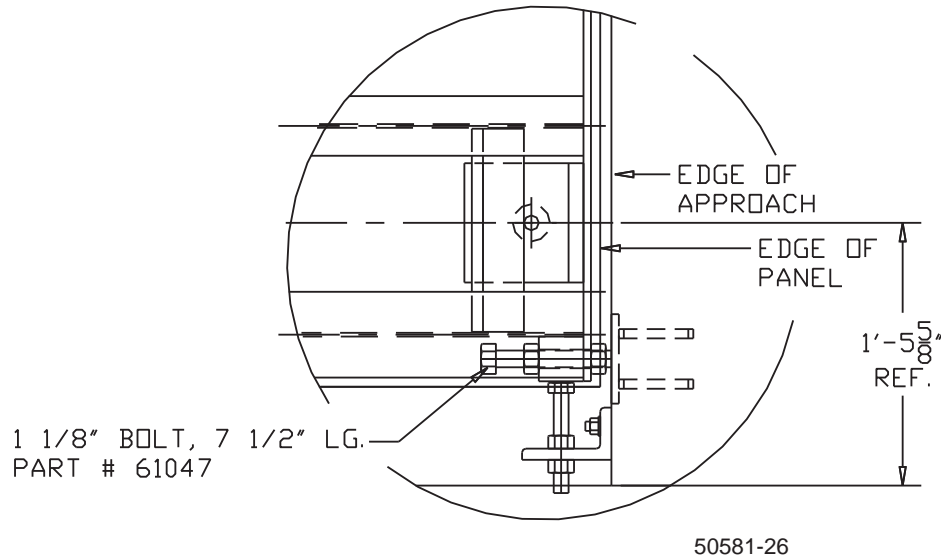

b. Install the side checking brackets:

- **Original Rodan types:** Bolt the brackets onto the end copings per the Certified drawings. Set the bolts so that they touch the channels they bump against.
- **E-Z Under Mounts:** Bolt the brackets to the end checking plates embedded in the end walls per Certified prints. Set the bolts so that they touch the channels they bump against.

7. Base Plate Completion:

- **Original Rodan types:** Check that all locating tools are properly aligned and flush with the receiver cups. Drill the holes for the base plate anchors using a hammer-drill and the 5/8" drill bit. Tap the anchors into clean holes and tighten the nuts securely.
- **E-Z Under Mounts:** Check that all locating tools are properly aligned and flush with the receiver cups. Drill the holes for the outside base plate anchors using a hammer-drill and the 5/8" drill bit. Tap the anchors into clean holes and tighten the nuts securely.



8. Installing Load Cells:

Note: Field-Pour scales are poured, formed and cured with locating tools in place. Do NOT install load cells until cure strength is reached (typically 28-30 days; use a core sample to confirm).

- a. Unpack the load cells and mark each calibration certificate with the cell location/position.
- b. Starting at one end of the assembled platform, place hydraulic jacks at the corners so the section can be lifted off the locating tool (2 hydraulic jacks may be required).
- c. Lift the platform so the load cell locating tool can be removed from the upper and lower bearing cups. Once removed, fill both cups with grease.



Caution: Use eye protection! Grease can 'shoot' out of the cup at high velocity!

- d. For 6" or 7^{1/2}" Load Cells, insert the load cell's upper end into the upper cup, and align so the anti-rotation pin in the cell goes between the two roll pins in the baseplate. The anti-rotation pin should be located on the cable entry side of the load cell.

For 5^{1/2}" or 7" load cells, the bottom of the cell has two flatsides which must be aligned with the flats in the lower cup. Carefully lower the scale (hydraulic jacks) while seating the bottom of the cell into the lower cup.

Check the scale's level and height, particularly at the approaches. Use the load cell shims provided to adjust load cell cups for correct height and to ensure that all cells share the proper amount of load. Center section cells will have up to twice the deadload of end section cells.

e. Once satisfied with height and level, tighten the module-to-module bolts.

- **Original Rodan types:** The bolts must be torqued to 690 ft lbs.
- **E-Z Under Mounts:** The bolts must be torqued to 500 ft lbs.

f. Load cell cables:

- **Original Rodan types:** Route the load cell cables through the holes in the channels to the SSC/PPS mounting bar location in the center. Install the strain relief 'clamps' for load cell cables on the strain relief base that is welded onto the scale.

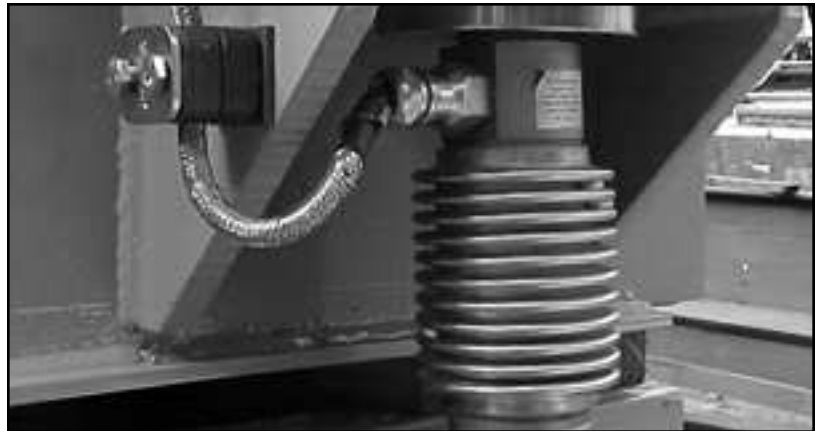

- **E-Z Under Mounts:** Route the 'far-side' load cell cables to the conduits that go under the scale. Install the strain relief 'clamps' for load cell cables on the strain relief base that is welded onto the scale, then run the cable end through the conduits to the PPS/SSC mounting bar locations on the side.

9. Final Checking Adjustment:

a. Adjust End Checking

- **Original Rodan types:** Remove shims on end checking to allow $1/16$ " to $1/8$ " clearance
- **E-Z Under Mount:** Adjust the End Checking Bolts to allow $1/16$ " to $1/8$ " clearance

b. Adjust side checking bolts to allow $1/16$ " clearance from channel

Section 4: Field Pour Installation

The Field Pour modules' installation is much the same as the other models, with some minor variations. The basic procedure is to install the foundation for the scale, install the base plates, position and level the shoring, install the platform modules with locator tools in place, pour the deck, cure the concrete, then install the load cells.

A. Concrete Specifications:

Use the Certified Prints for all concrete specifications.

B. Shoring:

The recommended shoring is made up of the provided 4" x 4" timbers 12 feet long. The "crown" of the shoring timbers should be up. The actual dimensions of the timbers will depend on the distance from the foundation floor to the bottom of the modules. Shims should be placed under each end and center of the shoring beams to achieve proper elevation. The shoring timbers should be located equally spaced between the load cells.

See drawing on following page.

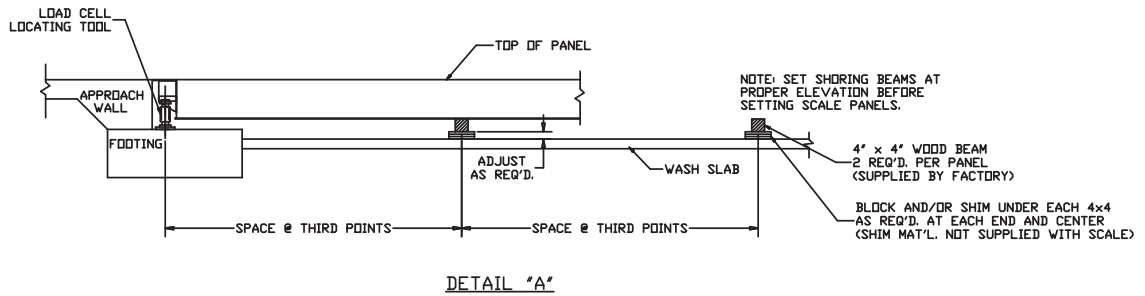
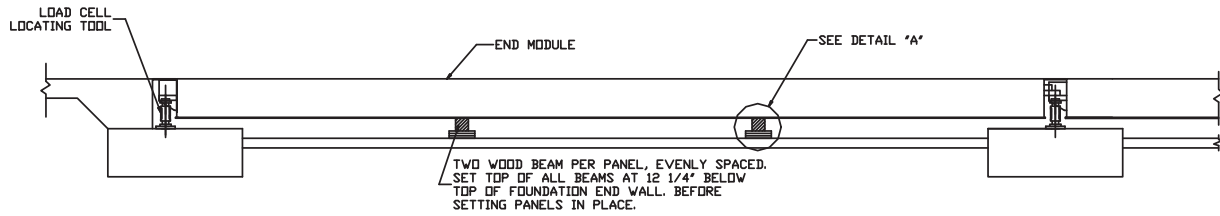
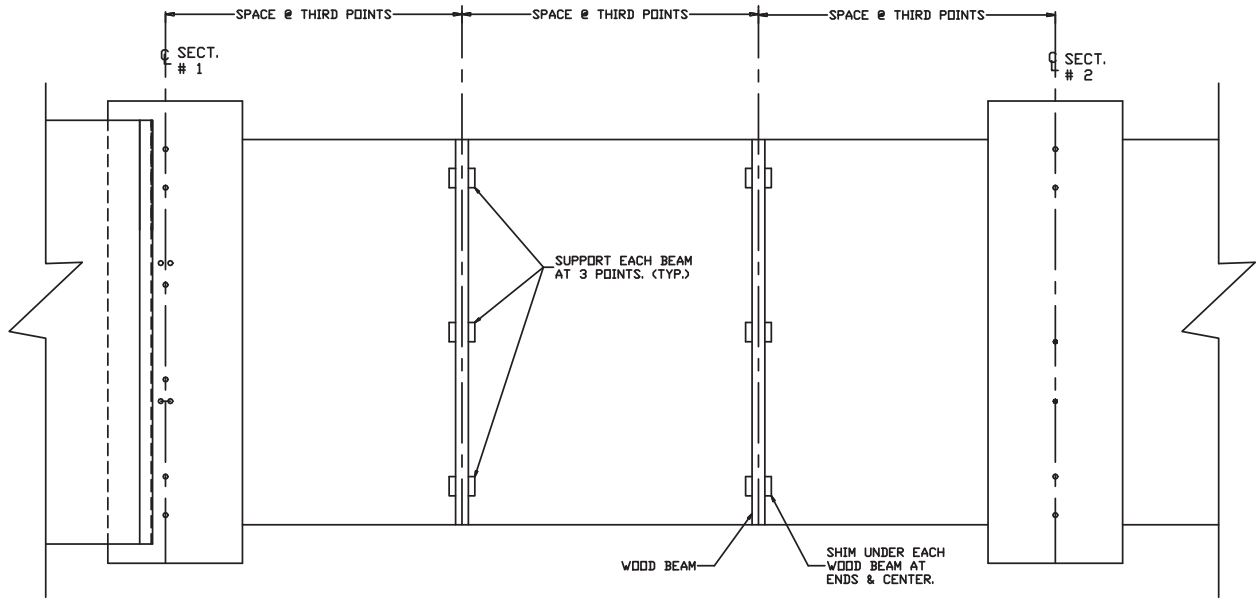

C. Setting the field pour modules:

1. The shoring timbers should be placed before setting scale modules. Using the approach walls as the reference, place the shoring timbers so they will be at the same elevation as the bottom of the weigh bridge. A tight string between the approach walls could be used.

2. Install the modules as outlined in Section 2C of this manual, starting with the center module.



WARNING: The modules **MUST** be set on loading tools. **Do Not support load cell bracket with lumber, as this will cause warping.**

3. Wedge additional shims as required under the end of the shoring timbers to ensure tight contact between the scale frame and the shoring.



Caution: Make sure the edge beams of the scale are straight and not bowed down, or in, before pouring the concrete deck. Do not install the load cells before the concrete deck is cured.

4. Pour the concrete. A spud-type vibrator is required to remove any air bubbles and to work the material into all of the corners.

5. A rough "broom" finish is recommended. Crown concrete $\frac{1}{4}$ " to allow drainage. Allow the concrete to cure until the required minimum strength as specified on the Certified Prints is achieved.



Caution: At the time the deck is poured, samples must be taken for later testing. At the end of 14 days, test the first sample. A sample must pass the test at 4,000 psi before the scale can be placed into service. A copy of the test report must be retained as part of the customer record in the service center or distributor location, otherwise warranty will be void.

6. After the concrete has cured, remove all of the shoring. The modules will have to be lifted so the shoring can be removed.



Warning : Place hydraulic jacks ONLY at the CORNERS of the modules. Hydraulic jacks must be placed on opposite sides to lift the module in a level position. Lifting mid-span or between load cells will cause cracks in the concrete.

7. Install the load cells in place of the locator tools.
8. Set end wall checking at $\frac{1}{8}$ " maximum, $\frac{1}{16}$ " minimum gap.
Set side wall checking at $\frac{1}{16}$ " gap.

Section 5: Electrical Installation

A. Balance Box 21912, Installation for Analog Indicators:

1. Introduction: Balance box 21912 is intended to be installed at the platform, one box per section.
2. Description: Each Stainless Steel balance box has four (4) terminal blocks to connect two (2) load cells and two (2) cables for connection to the analog instrument. Load cells and sections are adjusted by means of adjusting potentiometers.
3. Installation:

a. Boxes: The box has 'tabs' for bolting to adapters either in the space between modules, or on the side of the EZ Under Mount modules. Attach the ground wire lug to one of the mounting bolt studs. Tighten securely to provide a good electrical ground.

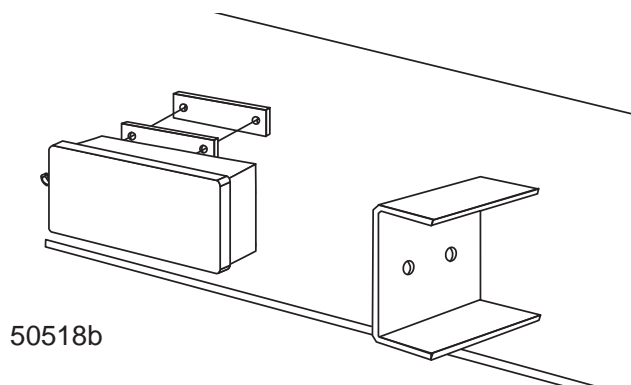

b. Wiring: Cable used in ALL wiring MUST be a minimum of 18 AWG. Use cable 17204 or an equivalent. The balance boxes are interconnected from TB4 to TB3 beginning at the end section where the interface cable conduit enters the scale. An alternate method if the conduit enters the scale in the middle is to use 14478 Instrument SVP. This will allow separate connections to go in each direction toward the ends of the scale. See Bulletin 50513 for the wiring diagrams.

B. Load Cell wiring color codes:

5 ½" RC Load Cell Color Code:

| Color | Description |
|--------|----------------|
| Black | (-) Excitation |
| Green | (+) Excitation |
| Red | (-) Signal |
| White | (+) Signal |
| Yellow | Shield |

6" RC Load Cell Color Code:

| Color | Description |
|--------|----------------|
| Black | (-) Excitation |
| Red | (+) Excitation |
| White | (-) Signal |
| Green | (+) Signal |
| Yellow | Shield |

7" RC Load Cell Color Code:

| Color | Description |
|--------|----------------|
| Black | (-) Excitation |
| Green | (+) Excitation |
| Red | (-) Signal |
| White | (+) Signal |
| Yellow | Shield |

7 ½" RC Load Cell Color Code:

| Color | Description |
|--------|----------------|
| Black | (-) Excitation |
| Green | (+) Excitation |
| Red | (-) Signal |
| White | (+) Signal |
| Yellow | Shield |

C. Wiring:

1.) Cells to Junction Box:

| Terminal | TB1 | TB2 |
|-----------------|------------|------------|
| 1 | (-) EXC | (-) EXC |
| 2 | (+) EXC | (+) EXC |
| 6 | Shield | Shield |
| 7 | (+) SIG | (+) SIG |
| 8 | (-) SIG | (-) SIG |

2.) Box to Box:

| Terminal | TB4 |
|-----------------|------------|
| 1 | (-) EXC |
| 2 | (+) EXC |
| 3 | (+) SENSE |
| 4 | (-) SENSE |
| 6 | SHIELD |
| 7 | (+) SIG |
| 8 | (-) SIG |

3.) Box to Instrument:

| Terminal | TB3 |
|-----------------|------------|
| 1 | (-) EXC |
| 2 | (+) EXC |
| 3 | (+) SENSE |
| 4 | (-) SENSE |
| 6 | SHIELD |
| 7 | (+) SIG |
| 8 | (-) SIG |



Note: The Full Electronic scales have been designed to provide protection from the effects of moisture. The load cells have been calibrated with the cable attached, therefore the cable should NOT be cut. The cable is connected directly to the balance box or SSC through a sealed bushing which MUST be tightened with pliers to keep water/moisture out of the box. All cabling should have a "drip loop" at the cell or box entry location to help prevent water entry. On all boxes, particularly Stainless Steel, the black plastic fittings have "O" rings that can be forced out of position if the bushing itself is not tight. To prevent this, first tighten the inner nut securing the bushing in the hole, then insert cable and carefully tighten gland with pliers until it is very snug. Do not over-tighten where bushing 'turns' . The cover MUST be secured with ALL screws tightened properly (18-20 in/lbs) for protection against moisture.



Note: Balance Boxes must have 1 pit ground rod in the pit for proper connection.



CAUTION: Without adequate ground(s), surge voltage protection installation is not complete.

4.) Indicator Cable Connection, Balance Box

The two (2) cables from the two (2) center section boxes will enter the 14478 Instrument SVP and terminate there. The cable from the indicator will connect at 14478 Instrument SVP as well. Prepare the cable ends in the standard manner. Use Appendix II for wiring instructions of all pit balance boxes. Connect the indicator interface cable to the instrument in the scale house per the instructions in the appropriate indicator service manual.

5.) Adjusting cells/sections:

Try to install load cells of matching outputs in sections to reduce side-to-side errors. When calibrating, place weights directly over the cell or directly on the section being tested. Adjust the potentiometers for the correct cell or section to compensate for differences.

6.) Cover Plates, Original Style:

The cover plates bridge the gap between modules. The plates are held in place with $\frac{3}{4}$ " x 1 $\frac{1}{2}$ " bolts. Use anti-seize or grease on the bolts and bolt holes.

D. Wiring SSCs and PPSs for Intalogix™ systems:

1. Introduction:

Intalogix™ systems utilize smart sectional controllers (SSCs) and pit power supplies (PPSs) for load cell excitation and signal processing.

2. Description:

There is one (1) SSC per section and one (1) PPS for the entire platform (unless the number and resistance of the cells require a second pit power supply). SSC boxes have four (4) terminals two (2) for load cells and two (2) for "inter connecting" to other SSC boxes or terminating to a pit power supply. All cell/section/scale adjustments are made via the Intalogix™ system instrument.

3. Installation:

a) Boxes: The box has 'tabs' for bolting to adapters either in the space between modules, or on the side of the EZ Under Mount modules.

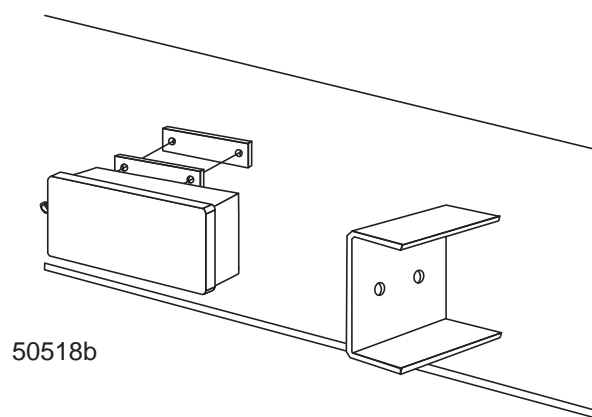

b) Wiring: Cable used in all wiring must be a minimum of 18 AWG. Use cable 17204 or 17246. Use appropriate service manual for the Indicator being installed, or Appendix III to connect PPSs and SSCs.



Note: Intalogix™ installations utilize a different numbering system for load cells because of digital addressing of the SSCs. Number cells as follows: With respect to the following starting position, face the platform from where the indicator is located. The cell at the upper left (far side) of the platform is Cell 1. The cell positions along the far side will be odd cell numbers, the near side locations will be even cell numbers.



Note: SSCs have connections for 2 load cells, TB 1 and TB 2. The odd numbered cell should go to TB1 connection, and the even numbered cell to TB2 connection.

E. SSC

Wire cells into each section's SSC per the appropriate manual. Remember, odd numbered cells go to cell 1 location, and even numbered cells go to cell 2 location. Load cell 'drain' wires connect to ground lug on the sectional controller box exterior.

F. Grounding, SSCs

1. Intalogix™ systems must have 2 ground rods in the pit for proper connection. Pit power supplies use a ground separate from the steel and SSC ground rod.

G. Indicator-to-PPS Cable Connection:

Prepare the cable ends in the standard manner. Use the appropriate manual for wiring instructions of all pit SSCs and power supplies. Connect the indicator interface cable to the instrument in the scale house per the instructions in the appropriate indicator service manual.

Section 6: Maintenance

Scale Maintenance:

1. Check for accumulations of solid material under the scale which may affect the accuracy, i.e., ice, frozen mud, debris.
2. Have the customer clean under the platform regularly.
3. Inspect load cells for damage to the ends/cables. Check cups and "O" rings for damage.
4. The load cell bearing cups should be inspected, cleaned and greased periodically.
5. Inspect and adjust all check bolts using anti-seize on the threads.

Mechanical Faults:

1. Check all clearances around the scale for any obstructions or interference with the free movement of the platform.
2. Check all check bolt clearances both with and without a concentrated load over each section, one at a time.
3. Check all load cells for plumb and level.
4. Inspect the boxes for leaks; the interior should be clean and dry. If there is moisture inside, clean, then dry it out thoroughly. Check that all connections at the terminal blocks are tight.

Section 7: Parts & Parts Replacement

A. Parts, Original Style

| Part No. | Description | Scale Types |
|----------|--|-------------|
| 54511 | 3/4" -10 x 1 1/2" Hex Bolt (cover plates) | Orig |
| 54236 | 3/4" Washer (cover plates) | Orig |
| 54207 | High Strength Bolt 1"-8 x 2 1/2" (for lifting brackets) | All |
| 64327 | Load Cell Base Plate | Orig |
| 61743 | Clamp Bar Washer (base plates) | All |
| 62857 | 5/8" x 6" Anchor Bolts | All |
| 63310 | Interlocking Pin (Original style Rodans) | Orig |
| 55010 | Ground Rod Kit | All |
| 62112 | Spray Paint, Rodan Gray | All |
| 63959 | Spacer 1/2" x 4" x 6" (module-module) | Orig |
| 54269 | High Strength Bolt 1" x 3" w/nut (module-module) | Orig |
| 54249 | Washer 1" (module-module) | Orig |
| 73682 | Shim, receiver cup, 1/16" | All |
| 64338 | Shim, receiver cup, 1/8" | All |
| 64334 | Shim, receiver cup, 3/16" | All |
| 63319 | Side check bracket w/bumper bolts (1" x 5") | |
| 64208 | Shim, longitudinal 1/4" | |
| 64209 | Shim, longitudinal 1/16" | |
| 70045 | Box, hardware, checking, consisting of: 8 each 64208 - Shim, end check, 1/4" 8 each 64209 - Shim, end check, 1/16" 4 each 64213 - Bumper check block 4 each 70043 - 8 x 3 urethane check block 1 each 70094 - Checking hardware kit | |

B. Parts, EZ Mount

| Part No. | Description | Scale Types |
|----------|--|-------------|
| 75458 | 1 1/8" -7 x 4 1/2" w/nut (module-module) | EZ Mount |
| 54788 | 1 1/8" Lock Washer (module-module) | EZ Mount |
| 54255 | 1 1/8" Flat Washer (module-module) | EZ Mount |
| 75397 | Load Cell Base Plate | EZ Mount |
| 61743 | Clamp Bar Washer (base plates) | All |
| 62857 | 5/8" x 6" Anchor Bolts | All |
| 55010 | Ground Rod Kit | All |
| 62112 | Spray Paint, Rodan Gray | All |
| 73682 | Shim, receiver cup, 1/16" | All |
| 64338 | Shim, receiver cup, 1/8" | All |
| 64334 | Shim, receiver cup, 3/16" | All |

C. Load Cells and Load Cell Hardware, ALL models:

LCF-HR4020-2A Flintec

| Part No. | Description | Scale Types (after 12/10/99) |
|-----------------|---|-------------------------------------|
| 70510 | Load Cell, 5½" RC, 30t,1000 Ohm, 2 mV/V | All SN 8131Q+ |
| 72274 | "O" Ring, 5½", INSIDE of Cup,*ANSI #222 | All |
| 64340 | "O" Ring, 5½",OUTSIDE of Cup*ANSI #228 | All |
| 70511 | Receiver Cup, 5½" LOWER (w/ anti-rotation pin) | All |
| 70512 | Receiver Cup, 5½", UPPER | All |
| 64382 | Roll Pin, 1/2" x 2½" anti-rotation, baseplate | All |
| 63981 | Anti-Rotation Pin, LOWER Receiver Cup 3/8" x 2 ½" | All |
| 71717 | Locating Tool 5½" | All |

651145-50K-1008H Sensortronics

| Part No. | Description | Scale Types (before 12/10/99) |
|-----------------|---|--------------------------------------|
| 63951 | Load Cell, 6" RC, 50K, 1000 Ohm, 2mV/V | Orig (before 12/10/99) |
| 63952 | Spacer 1½", (for use with 6" load cell) | Orig |
| 98359 | "O" Ring, 7½" RC Load Cell, cell ENDS, *ANSI #218 | All |
| 64340 | "O" Ring, 6" Cup, OUTSIDE, *ANSI #228 | All |
| 66980 | Receiver Cup, 6" (Upper and Lower) | All |
| 64382 | Roll Pin, ½" x 2½" anti-rotation, Baseplates | All |
| 63981 | Anti-Rotation Pin, Load Cell, 3/8" x 2 ½" | All |
| 64354 | Locating Tool 6" | Orig |
| 72139 | Load Cell, 7" RC, 50t,1000 Ohm, 2 mV/V | All |
| 98947 | "O" Ring, 7", INSIDE of Cup,*ANSI #327 | All |
| 64340 | "O" Ring, 7",OUTSIDE of Cup*ANSI #228 | All |
| 75952 | Receiver Cup, 7" LOWER (w/ anti-rotation pin) | All |
| 75951 | Receiver Cup, 7", UPPER | All |
| 64382 | Roll Pin, ½" x 2½" anti-rotation, base plate | All |
| 63981 | Anti-Rotation Pin, LOWER Receiver Cup 3/8" x 2 ½" | All |
| 76623 | Locating Tool 7" | All |

LCF-HR4020-1 Flintec

| Part No. | Description | Scale Types (before 10/98) |
|-----------------|---|-----------------------------------|
| 63215 | Load Cell, 7½" RC, 56K, 350 Ohm, 2 mV/V | Orig (before 10/98) |
| 98359 | "O" Ring, 7½" RC Load Cell, cell ENDS, *ANSI #218 | All |
| 64340 | "O" Ring, 7½" RC Cup, OUTSIDE, *ANSI #228 | All |
| 66980 | Receiver Cup, 7½" RC Load Cell (Upper and Lower) | All |
| 64382 | Roll Pin, ½" x 2½" anti-rotation, Baseplates | All |
| 63981 | Anti-Rotation Pin, Load Cell, 3/8" x 2 ½" | All |
| 64350 | Locating Tool 7½" | All |
| 73967 | LCL Receiver cup | All |

LCF-HR4020-2**Flintec**

| 64166 | Load Cell, 7½" RC, 50K, 1000 Ohm, 2 mV/V | All |
|--------------|---|------------|
| 98359 | "O" Ring, 7½" RC Load Cell, cell ENDS, *ANSI #218 | All |
| 64340 | "O" Ring, 7½" RC Cup, OUTSIDE, *ANSI #228 | All |
| 66980 | Receiver Cup, 7½" RC Load Cell (Upper and Lower) | All |
| 64382 | Roll Pin, ½" x 2½" anti-rotation, Baseplates | All |
| 63981 | Anti-Rotation Pin, Load Cell, 3/8" x 2 1/2" | All |
| 64350 | Locating Tool 7½" | All |
| 21912 | Summing Junction Box - complete | |
| 21842 | Summing Junction PC Assembly | |

* **ANSI# XXX:** defines a standard "O" ring size. "O" rings may be obtained at many hardware, hydraulic, or plumbing supply houses by using the number.

D. "O" Rings:

2 1/4" I.D.
2 1/2" O.D.
1/8" Thickness

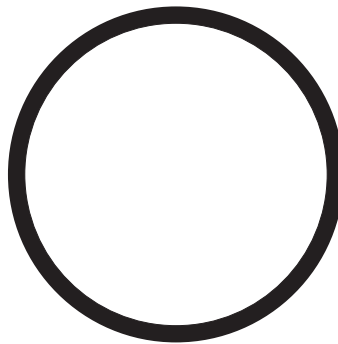

Part No. 64340
ANSI # 228
Outside of all
load cell cups

1 3/4" I.D.
2 1/8" O.D.
3/16" Thickness

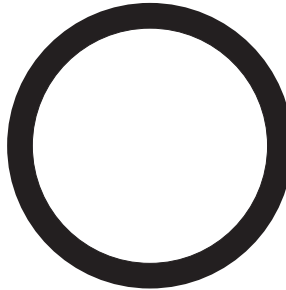

Part No. 98947
ANSI # 327
Inside of cup 7"
load cells

1 1/2" I.D.
1 3/4" O.D.
1/8" Thickness

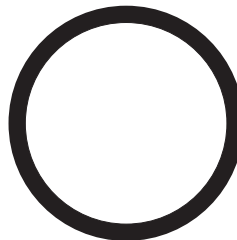

Part No. 72274
ANSI # 222
Inside of cup
5 1/2" load cells

1 1/4" I.D.
1 1/2" O.D.
1/8" Thickness

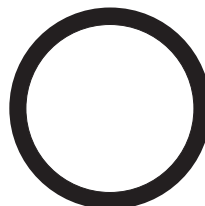

Part No. 98359
ANSI # 218
load cell ends
6" and 7 1/2"

E. Replacing an RC load cell:

1. Remove power from the instrument.
2. Lift the scale using a proper sized and rated hydraulic jack(s) at the corner(s) closet to the "defective" cell location.

Warning: Lift scales ONLY at the corners. On field pour and MegaBar™ scales, use 2 properly 'rated' hydraulic jacks at opposite sides at the corners, and lift the section in a level fashion.

3. Disassemble the strain relief device, then remove the old cell.
4. Check upper and lower receiving cups and "O" rings for damage. Replace as necessary and reapply grease.
5. Insert the new cell into the upper receiving cup and position the anti-rotation pin.
6. Carefully lower the hydraulic jack(s) until the cell is set into the lower cup.
7. Remove the cover of the SSC/Jct box, then loosen the gland bushing to free the cable. Remove the old cell wires and connect new cell wires in the balance Box/SSC. Torque the cover screws to 18-20 in/lbs and tighten all gland nuts with a wrench to secure.
8. Test and adjust scale as necessary.



F. General Load Cell Information:

| Load Cell Part No. | Description | Comments |
|---------------------------|---|-----------------|
| 70510 | 5½", 2 mV/V, 66K or 30t, 1000 Ohm | |
| 63951 | 6", 2 mV/V, 50K, 1000 Ohm | |
| 72139 | 7", 2 mV/V, 110K or 50t, 1000 Ohm | |
| 63215 | 7½", 2 mV/V, 56K or 25t, 350 Ohm, Used Before 10/98 | |
| 64166 | 7½", 2 mV/V @ 56K or 25t, 1000 Ohm | |

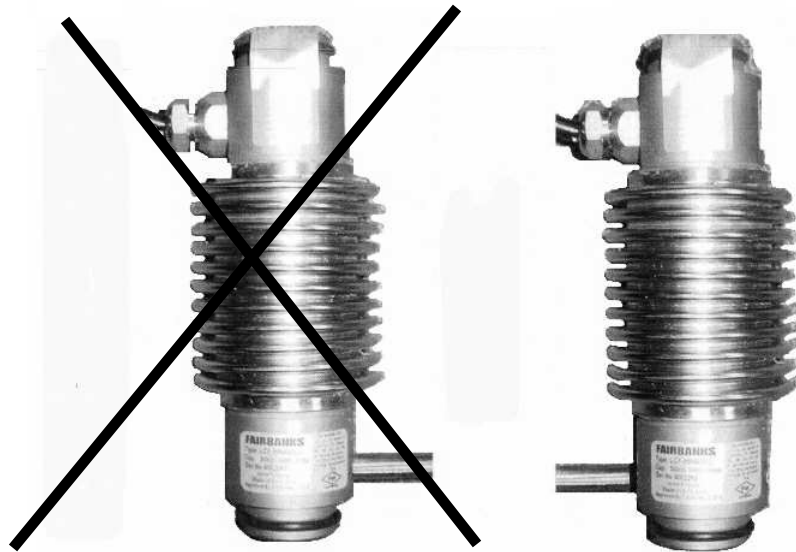

Correct Anti-Rotation Pin Orientation

Section 8: Accessories

Rub-Rails: These accessories come in Factory installed and Field installed types.

A. Field Installed Rub Rail Installation:

- Use the print with the accessory for actual measurements.
- Clean (remove primer) the areas to be welded for good penetration.
- Weld stiffeners to the side weldments.
- Bolt the gussets to the stiffeners and end weldments.
- Weld pipe to the gussets.
- Clean and paint (paint provided) all weld areas.

Warning: Fairbanks does NOT recommend using foundation or ground installed guide rails along the sides of a truck scale platform. Damage may occur to the scale if a truck hits the guide rail, transferring damaging forces to the platform and the checking system. Use of this style guide rail will void product warranty.

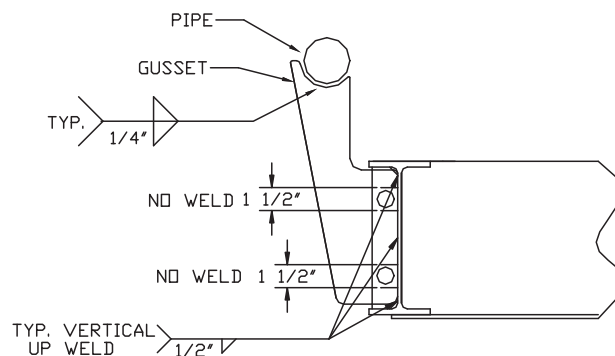
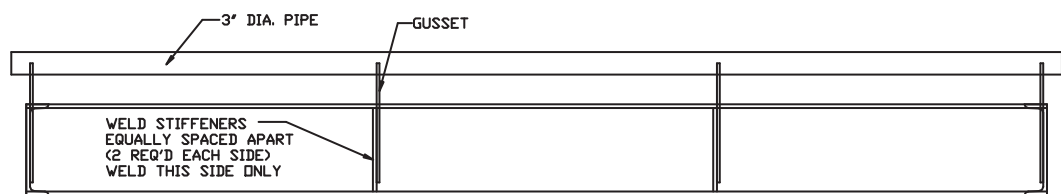

50518-19

Appendix I: Foundation Check List



Foundation Inspection

FOUNDATION FIELD CHECK LIST (Field Form)

A Foundation Inspection **should ALWAYS** be performed prior to scale installation and to **confirm** correct foundation construction. If possible this should be done prior to scale shipment.

- Tools required:**
- Certified drawings and site plan
 - 100' and 25' steel tapes
 - Laser or builders level if possible
 - Straight edge for pit foundations (2 x 4, very straight and 4" wider than pit walls)
 - Construction paint (up-side-down type, for marking concrete).
 - 2' to 4' level
 - Hammer and concrete nails
 - String line (construction string)

Perform the following Foundation Checks. Refer to Methods and Procedures for complete description of each step. Recommended to copy check list and keep in job file. ALWAYS familiarize yourself with the **CERTIFIED** foundation prints for the job you are working on as model numbers and specifications are subject to change.

- 1. **Site Plan and Certified Prints** should be thoroughly reviewed to confirm accurate locations to the scale and all extra items (scoreboards, lights, poles, etc.) that are included in the bid or contract.
- 2. **Check for truck and crane access**, overhead wires, fences, green concrete, etc.
- 3. **Dimensional length and width check**; check all 4 sides and record on chart (other side).
- 4. **Diagonal measurements** check to verify that the foundation is square and record on chart (other side). These measurements should be equal, or within 1/2". Greater error could result in the scale not fitting in the foundation.
- 5. **Check ALL pier heights** to make sure they are the proper elevation and record on chart (other side). Too high and the scale will not fit correctly, too low could result in excessive shimming..
- 6. **In pit foundations check walls to verify they are straight.** Straight walls are very important, but are even more critical for modular scales like the Rodan series.
- 7. **Verify conduit locations** and pull strings (if needed).
- 8. **Verify ground rod locations.**
- 9. **Verify that drains and sump openings** are piped correctly and are clear of debris.
- 10. **Check the end coping** to ensure they are centerline and that the coping is correct for the scale being installed (10', 11' or 12' width, etc). Check all coping, side and end, for hollow areas.
- 11. **Verify location of any and all required embeds or pre-installed baseplates** (i.e., Hwy System, RR scales, etc). All of these dimensions will be located on the Certified foundation prints.
- 12. **Layout** - To help in locating pre-installed baseplates, embeds, load-cell centerlines, etc., refer to Methods and Procedures section on Layout. **See other side for foundation & Layout charts.**

FF-2267

Issue #1

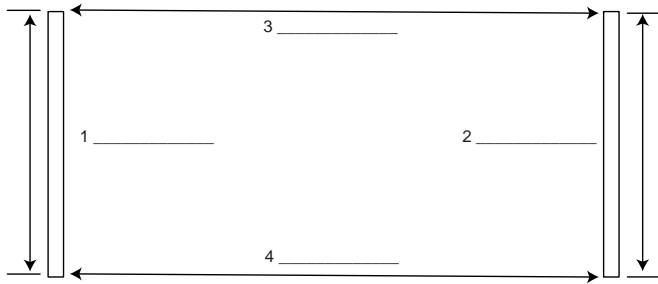

Length & Width Check

Diagonal Measurements Check

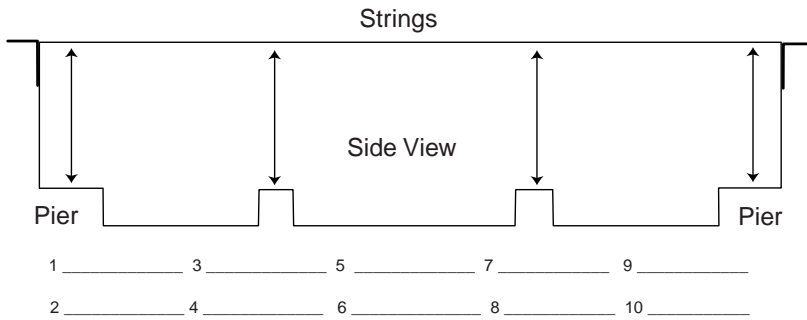
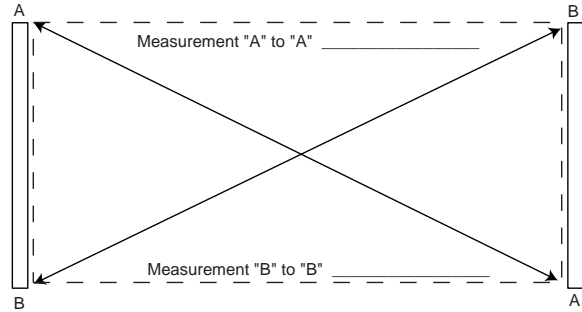

Pier Height Check

Longitudinal Layout

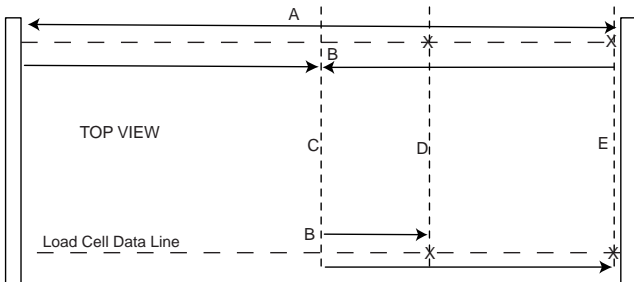
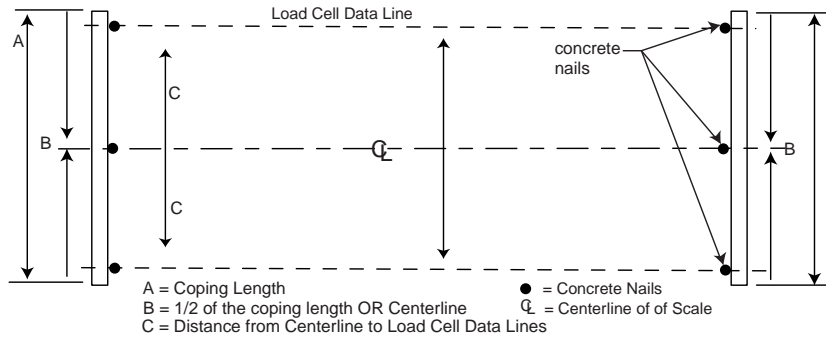

Lateral Layout

FF-2267

Issue #1

Appendix II: 4 Section Analog Scale

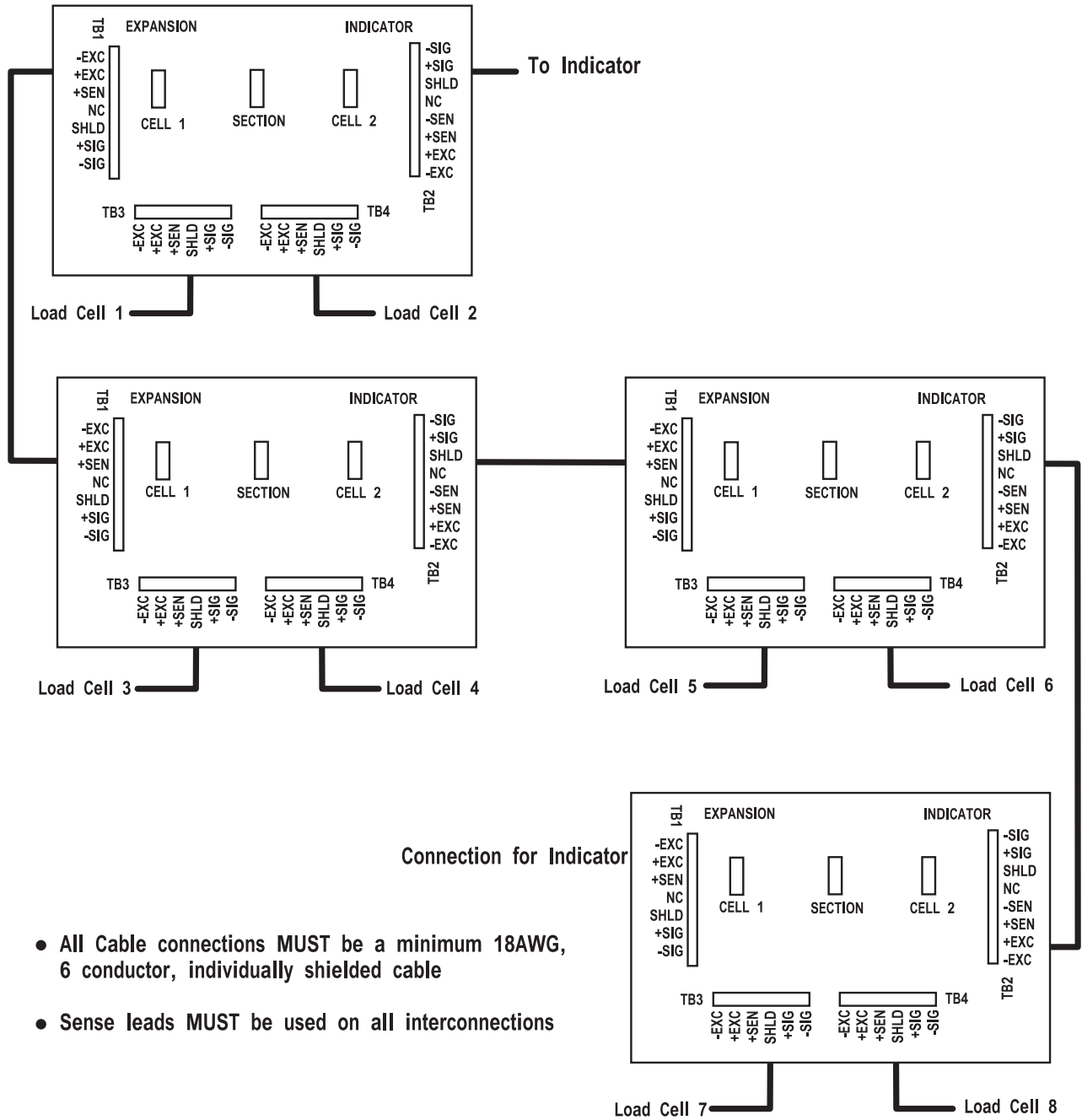

4 Section Analog

Appendix III: 5 Section Analog Scale

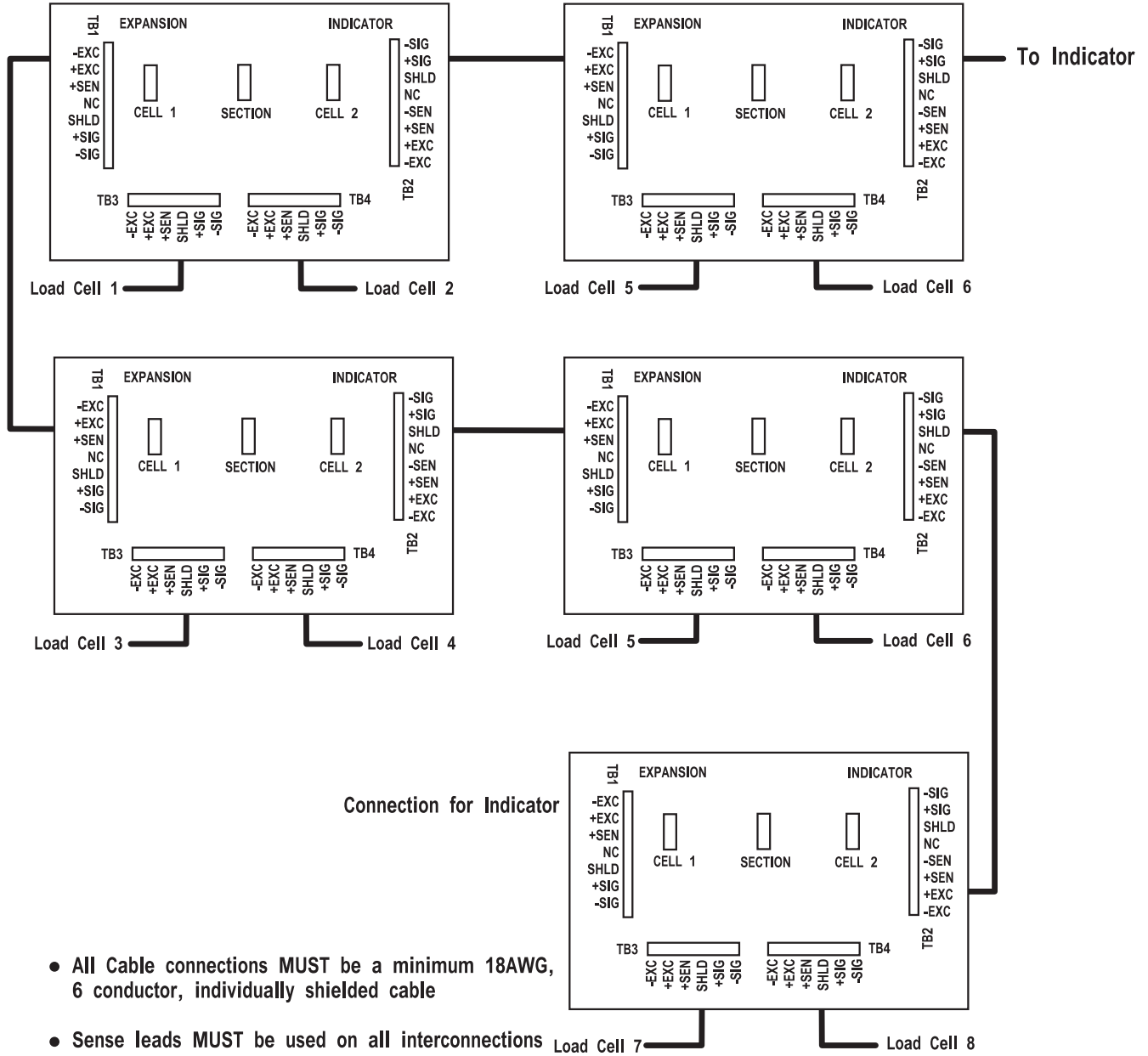

Appendix IV: 4 Section Intalogix Scale

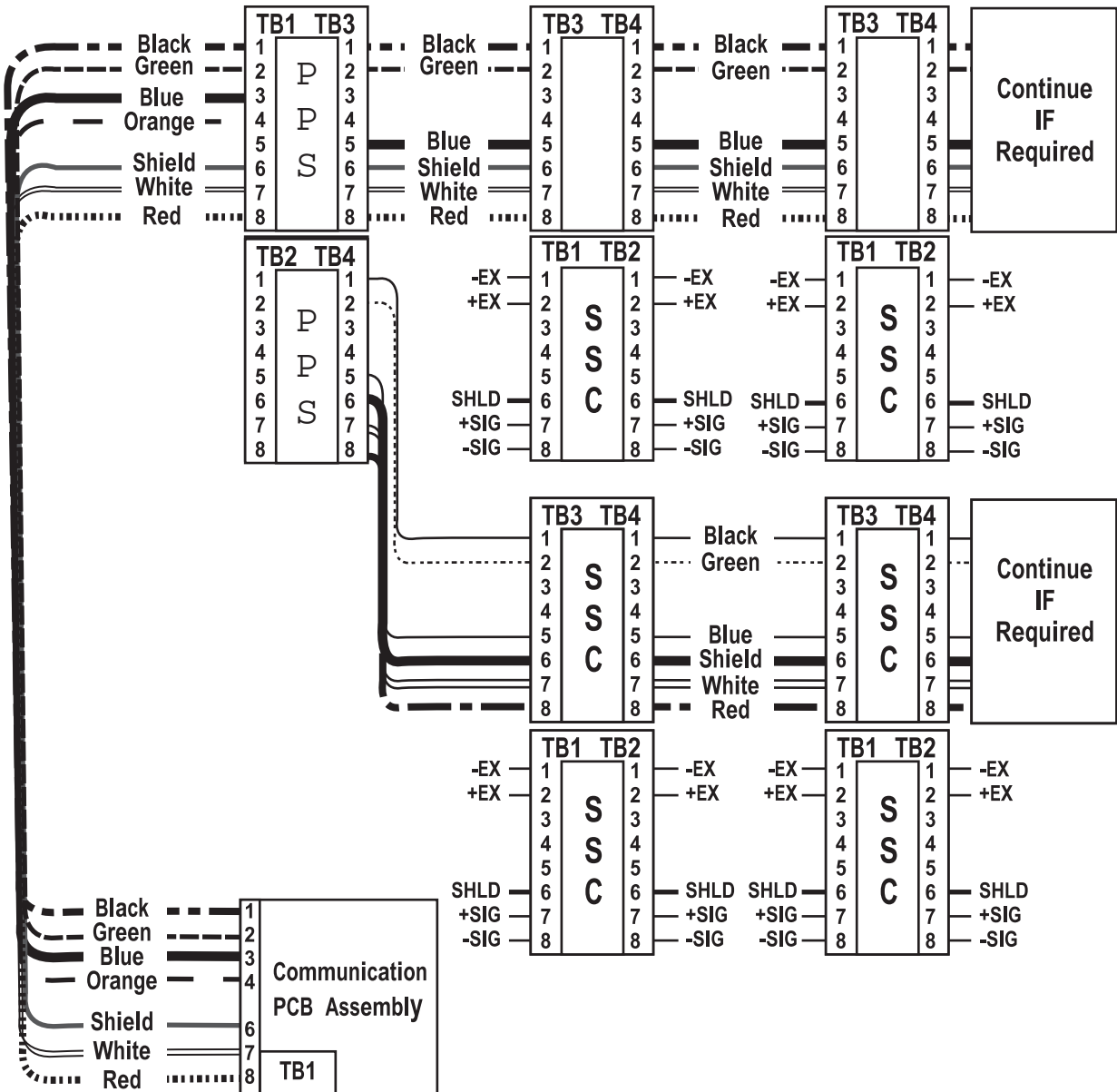

PPS at Midsection